

Department of Physics and Electrical Engineering

Jin Xinzhu

**Channel Estimation Techniques of
SC-FDMA**

Master's Thesis

2007

Channel Estimation Techniques of SC-FDMA

Jin Xinzhu

This thesis is submitted in partial fulfillment of the requirements for the Masters degree in Electrical Engineering. All material in this thesis which is not my own work has been identified and no material is included for which a degree has previously been conferred.

Jin Xinzhu

Approved, 2007-11-21

Advisor: Arild Moldsvor

Examiner: Andreas Jakobsson

Abstract

This master thesis investigates several different channel estimation techniques in an SC-FDMA (Single Carrier Frequency Division Multiple Access) system with parameters set according to the standards of 3GPP LTE (3rd Generation Partnership Project Long Term Evolution). 3GPP LTE is the name given to a project within the 3GPP to improve the mobile phone standard to cope with future requirements. In this thesis, we first introduce the SC-FDMA system, which is a transmission technique that utilizes single carrier modulation, then five types of estimators are investigated. Essential to all channel estimations is the use of pilot symbols. In the last part we compare the performance of the channel estimation techniques with each other in different environments by analysing their symbol error rates. All simulations are done in a Matlab environment.

Acknowledgements

I'd like first to give my thanks to Daniel Larsson, who gave me a lot of support when I was in TietoEnator. Then, I'd like to give my thanks to my supervisor, Dr.Arild Moldsvor, who gave me many advices on my report. I also would like to thank the company–TietoEnator, for giving me a chance to study there. Most important of all, thanks to my parents for their great support all the time.

Contents

| | | |
|----------|--|-----------|
| 1 | Introduction | 1 |
| 1.1 | Development of Cellular Wireless Communication | 1 |
| 1.2 | 3GPP LTE and SC-FDMA | 2 |
| 1.3 | Objectives | 3 |
| 1.4 | Organization | 3 |
| 2 | Basic Principle of SC-FDMA | 5 |
| 2.1 | Orthogonal Frequency Division Multiplexing (OFDM) | 5 |
| 2.2 | Single Carrier with Frequency Domain Equalization (SC/FDE) | 6 |
| 2.3 | Cyclic Prefix (CP) | 8 |
| 2.4 | SC-FDMA and OFDMA | 9 |
| 2.5 | Application of SC-FDMA in 3GPP LTE Uplink | 11 |
| 2.5.1 | Modulation scheme | 11 |
| 2.5.2 | Frame format | 11 |
| 3 | System Model | 13 |
| 3.1 | Overview of the SC-FDMA system | 13 |
| 3.2 | Transmission model | 15 |
| 3.2.1 | Constellation | 15 |
| 3.2.2 | Subcarrier Mapping | 15 |

| | | |
|----------|---|-----------|
| 3.2.3 | Pilot insertion | 18 |
| 3.3 | Channel Model | 19 |
| 3.3.1 | Characteristics of the Fading Channel | 19 |
| 3.3.2 | Noise addition | 20 |
| 3.4 | Model structure settings | 21 |
| 4 | Channel estimation | 23 |
| 4.1 | 1D estimator | 23 |
| 4.1.1 | Least Square (LS) channel estimator | 23 |
| 4.1.2 | Finite Impulse Response (FIR) interpolation algorithm | 25 |
| 4.1.3 | LMMSE estimation | 27 |
| 4.1.4 | Gauss-Markov estimation | 28 |
| 4.2 | 2D estimator | 29 |
| 4.3 | Adaptive estimator | 30 |
| 4.3.1 | LMS algorithm | 30 |
| 4.3.2 | NLMS algorithm | 31 |
| 4.4 | Estimator summary | 32 |
| 4.4.1 | 1D estimator | 32 |
| 4.4.2 | 2D estimator | 33 |
| 4.4.3 | Adaptive estimator | 33 |
| 5 | Simulations | 35 |
| 5.1 | The test case | 35 |
| 5.2 | Results and analysis | 36 |
| 5.2.1 | Simulation results | 36 |
| 5.2.2 | Analysis | 39 |
| 6 | Conclusions and Future work | 41 |

List of Figures

| | | |
|-----|--|----|
| 2.1 | Block diagram of OFDM and SC/FDE | 6 |
| 2.2 | Differences between OFDM and SC/FDE | 7 |
| 2.3 | Guard time removes IBI | 8 |
| 2.4 | Cyclic Prefix removes IBI | 9 |
| 2.5 | Block diagrams of OFDMA and SC-FDMA | 9 |
| 2.6 | Differences between OFDMA and SC-FDMA | 10 |
| 2.7 | Sub-frame structure in time domain | 11 |
| 2.8 | Physical Mapping of one block in RF frequency domain | 12 |
| 3.1 | System Model | 14 |
| 3.2 | Differences among subcarrier mapping modes | 16 |
| 3.3 | Positions of data and pilot | 18 |
| 3.4 | Channel model | 22 |
| 4.1 | Pilot estimation and interpolation | 26 |
| 4.2 | Structure of subcarriers in one frame | 29 |
| 5.1 | Simulation result under 3km/h (Part1) | 36 |
| 5.2 | Simulation result under 3km/h (Part2) | 37 |
| 5.3 | Simulation result under 50km/h (Part1) | 37 |
| 5.4 | Simulation result under 50km/h (Part2) | 38 |
| 5.5 | Simulation result under 120km/h (Part1) | 38 |

| | |
|---|----|
| 5.6 Simulation result under 120km/h (Part2) | 39 |
|---|----|

List of Tables

| | | |
|-----|--|----|
| 2.1 | Parameters for Uplink Transmission Scheme | 12 |
| 3.1 | Default mobile speeds for the channel models | 20 |
| 3.2 | Typical Urban channel model (TUx) | 21 |
| 3.3 | Structure settings in simulation | 22 |
| 5.1 | Settings for the simulations | 36 |
| 5.2 | Time consumption of estimation methods | 40 |

Chapter 1

Introduction

This master thesis analyses the effects of different channel estimation techniques in an SC-FDMA (Single Carrier Frequency Division Multiple Access) system using the standards of 3GPP. This first chapter introduces some related background information, defines the problems that should be solved, and gives an outline of the report.

1.1 Development of Cellular Wireless Communication

No doubt, cellular phones have become an important tool and part of everyday life nowadays. In the last decade, cellular systems have experienced rapid growth and there are currently about two billion users over the world [1].

The concept of cellular wireless communications is to divide large zones into small cells, and it can provide radio coverage over a wider area than the area of one cell. This concept was developed by researchers at AT&T Bell Laboratories during the 1950s and 1960s [1]. The first cellular system was created by Nippon Telephone and Telegraph (NTT) in Japan, 1979. From then on, the cellular wireless communication has evolved.

The first generation of cellular wireless communication systems utilized analog communication techniques, and it was mainly built on frequency modulation (FM) and frequency

division multiple access (FDMA).

Digital communication techniques appeared in the second generation systems, and spectrum efficiency was improved obviously. Time division multiple access (TDMA) and code division multiple access (CDMA) are utilized as the main multiple access schemes. The two most widely accepted 2G systems are GSM (Global System for Mobile) and IS-95.

The concept of the third generation (3G) system was firstly brought up in the mid-1980s, as IMT-2000 (International Mobile Telecommunications-2000) was born at the ITU (International Telecommunication Union). In the year of 2000, two outstanding standards under IMT-2000 were made, they are UMTS/WCDMA (Universal Mobile Telecommunication System/ Wideband CDMA), which have evolved into so-called “3.5G” [2].

1.2 3GPP LTE and SC-FDMA

The 3rd Generation Partnership Project (3GPP) is a collaboration agreement that was established in December 1998. 3GPP LTE (Third Generation Partnership Project Long Term Evolution) is the name given to a project within the 3GPP to improve the mobile phone standard to cope with future requirements [3]. Current working assumptions in 3GPP LTE are to use OFDMA for downlink and SC-FDMA for uplink [4].

SC-FDMA is a modified form of OFDMA (Orthogonal Carrier Frequency Division Multiple Access), and it is a promising technique for high data rate transmission [2]. The main advantage of SC-FDMA is that it utilizes single carrier modulation and frequency domain equalization. Single carrier transmitter structure leads to a low PAPR (peak-to-average power ratio) [5], which is related to energy consumption.

An overview of SC-FDMA is given in [2], [5], [6] and [7]. A general description of 3GPP LTE is given in [3], and the standards of it can be found in [4] and [8]. The channel model is introduced in [9]. Channel estimations are described in [10], [11], [12], [13] and [14].

1.3 Objectives

- Introduction to SC-FDMA, a new single carrier multiple access technique, which is a working assumption for the uplink multiple access scheme in 3GPP Long Term Evolution. In this thesis, an entire SC-FDMA system will be investigated in particular, compared with the OFDMA system.
- Analysis of different kinds of channel estimations give different results, and in this thesis, we will introduce principles of different channel estimators.
- Simulation results of different situations will be presented. We will give the result of each simulation in different situation.

1.4 Organization

The outline of the thesis is as follow.

Chapter 2 introduces some basic principles of SC-FDMA. In this chapter, we will first investigate OFDM and SC-FDE (Single Carrier Frequency Domain Equalization), then we will compare SC-FDMA with OFDMA to see the similarities and dissimilarities. After that, an introduction to the implementation of SC-FDMA in 3GPP LTE uplink will be given.

Chapter 3 introduces an SC-FDMA system model. In this part, we will divide it into two parts, “transmission model” and “channel model”. We will also introduce some parameters which are important for the simulation.

Chapter 4 investigates different types of channel estimation techniques, they are LS (Least Square) estimation, FIR (Finite Impulse Response) estimation, Gauss-Markov estimation, LMMSE (Least Minimum Mean Square Error) estimation and NLMS (Normalized Least Mean Square) estimation. Moreover, we will give detailed algorithms of each estimation technique, and find out which is the more efficient one.

Chapter 5 gives detailed simulation results. We will run the simulations in different conditions which are determined by changing the parameters. We run it under different noise, different speeds, and different modulations schemes. Our aim is to investigate the characteristics of the system and the quality of the estimation techniques.

Chapter 6 presents a summary and prospect for future work.

Chapter 2

Basic Principle of SC-FDMA

2.1 Orthogonal Frequency Division Multiplexing (OFDM)

Frequency-division multiplexing (FDM) is a form of signal multiplexing where multiple baseband signals are modulated on different frequency carrier waves and composited into one signal. However, Orthogonal Frequency Division Multiplexing (OFDM) is a multi-carrier modulation technique which utilizes orthogonal subcarriers to transmit information. Compared with FDM, OFDM can transmit several signals simultaneously in different frequencies.

The main advantages of OFDM are:

- Complexity is low.
- Spectral efficiency is high.

However, it is suffered by some drawbacks:

- High peak-to-average power ratio (PAPR).
- High sensitivity to frequency offset.

For more details about FDM and OFDM, see [11] and [13].

2.2 Single Carrier with Frequency Domain Equalization (SC/FDE)

Frequency domain equalization of single carrier modulated signals has been known since the early 1970's. Single carrier systems with frequency domain equalization (SC/FDE), which are combined with FFT (Fast Fourier Transform) processing and contain the cyclic prefix, have the similar low complexity as OFDM systems [7].

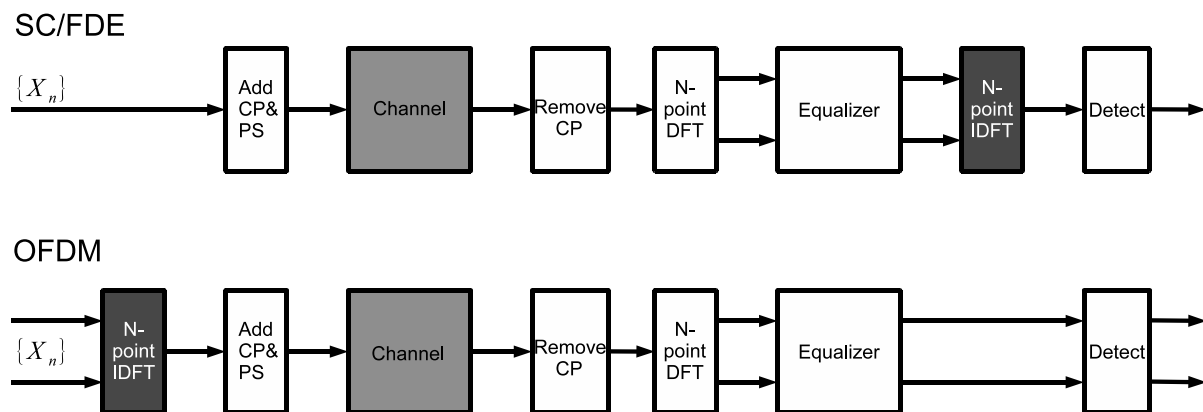

* CP:Cyclic Prefix, PS: Pulse Shaping

Figure 2.1: Block diagram of OFDM and SC/FDE

We can see from Figure 2.1 that OFDM and SC/FDE have similar structures, the only difference of their block diagram is the position of IDFT, so we may expect that these two have similar performance and efficiency.

2.2. SINGLE CARRIER WITH FREQUENCY DOMAIN EQUALIZATION (SC/FDE)

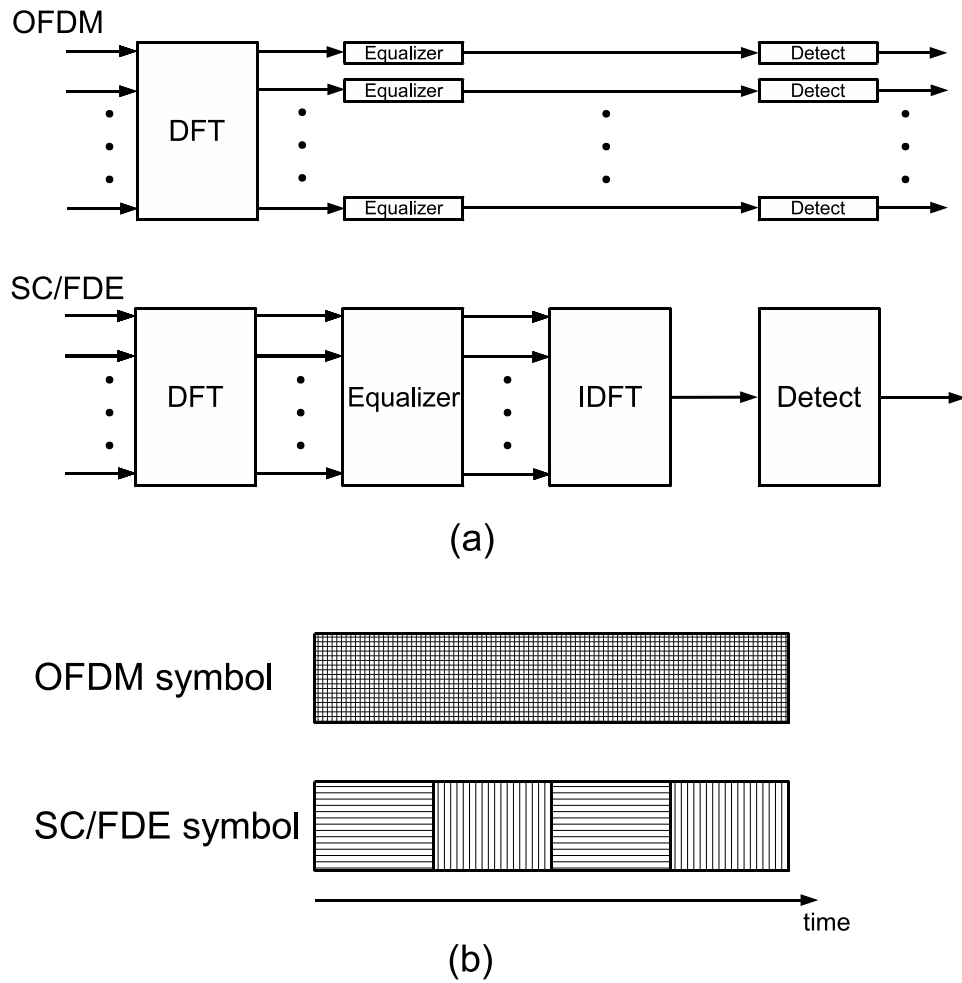

Figure 2.2: Differences between OFDM and SC/FDE

However, Figure 2.2 shows differences between OFDM and SC/FDE. In OFDM, detection takes place in frequency domain, all the symbols are allocated in the whole bandwidth, and extracted simultaneously. In SC/FDE, due to the IDFT processing before detection, symbols are extracted in time domain, and they are dealt with one by one.

SC/FDE has some advantages as follow:

- The inherent single carrier structure causes lower peak-to-average power ratio (PAPR) than OFDM.
- SC/FDE has lower sensitivity to carrier frequency offset than OFDM.
- SC/FDE has similar complexity as OFDM in the receiver, and even lower than OFDM in the transmitter, which will benefit the user terminals.
- SC/FDE has similar performance as OFDM.

2.3 Cyclic Prefix (CP)

Utilizing a cyclic prefix is an efficient method to prevent IBI (Inter-Block Interference) between two successive blocks. In general, CP is a copy of the last part of the block [6]. The existence of CP has a double effect preventing IBI [11].

1. CP provides a guard time between two successive blocks. If the length of CP is longer than the maximum spread delay of channel, there won't be any IBI, see Figure 2.3.

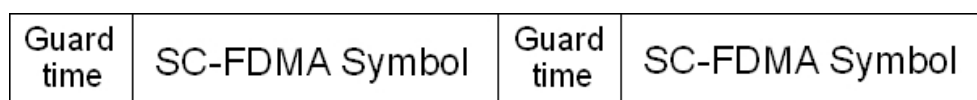

Figure 2.3: Guard time removes IBI

2. Because CP is a copy of the last part of the block, it will avoid the ICI (Inter Carrier Interference) between subcarriers.

However, the drawback of the cyclic prefix is that it doesn't carry any new information, so it will lower the efficiency of the transmission.

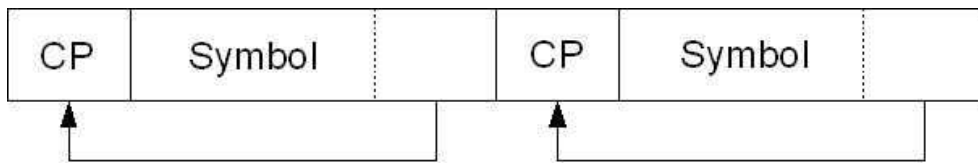

Figure 2.4: Cyclic Prefix removes IBI

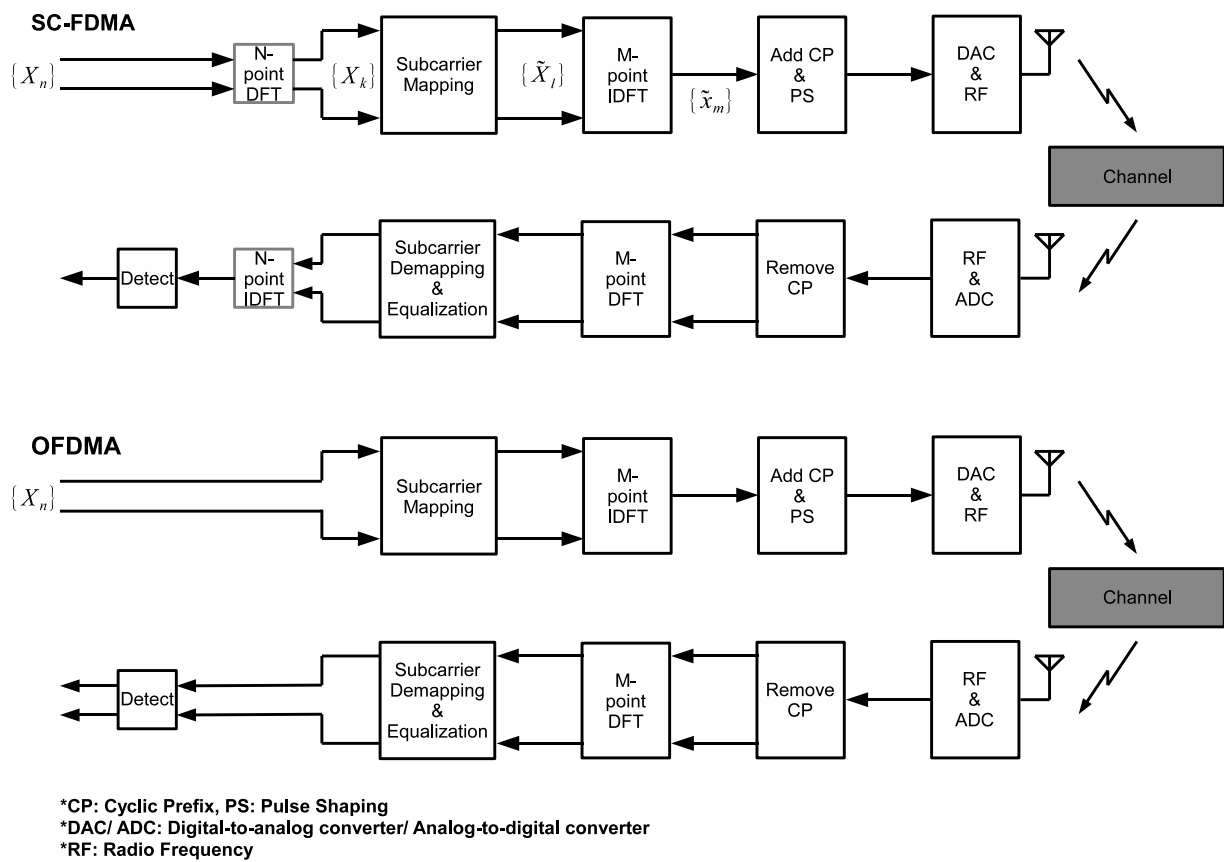

Figure 2.5: Block diagrams of OFDMA and SC-FDMA

2.4 SC-FDMA and OFDMA

From Figure 2.5, we can see that OFDMA and SC-FDMA have similar structures. The only difference is that SC-FDMA has more DFT processing, so we can consider SC-FDMA

as a DFT-spread OFDMA. However, as we introduced the differences between OFDM and SC/FDE in Section 2.2, OFDMA and SC-FDMA also have dissimilarities.

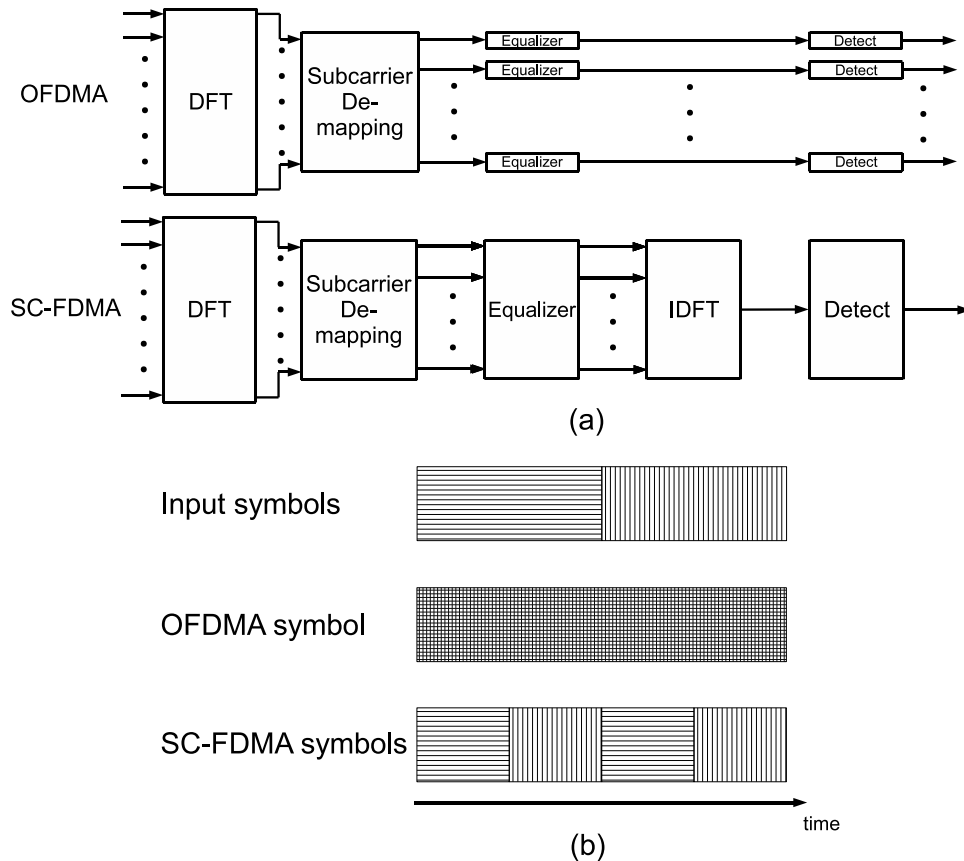

Figure 2.6: Differences between OFDMA and SC-FDMA

As Figure 2.6 shows, SC-FDMA first adds an Inverse Discrete Fourier Transform (IDFT) operation before detection, so that SC-FDMA is less sensitive to a null in the channel spectrum. In addition, the type of transmission in OFDMA is sending several symbols simultaneously, while in SC-FDMA, each symbol is divided into certain smaller blocks, and they are sent with other blocks, which come from other symbols, in a certain order.

2.5 Application of SC-FDMA in 3GPP LTE Uplink

As we know, SC-FDMA is utilized in the uplink of 3GPP LTE. In this section, we will describe the implementation of SC-FDMA in 3GPP LTE uplink.

2.5.1 Modulation scheme

The modulation scheme used in 3GPP LTE uplink are BPSK ($\pi/2$ -shifted), QPSK, 8PSK and 16QAM [4].

2.5.2 Frame format

In 3GPP LTE, a frame is the basic unit in transmission.

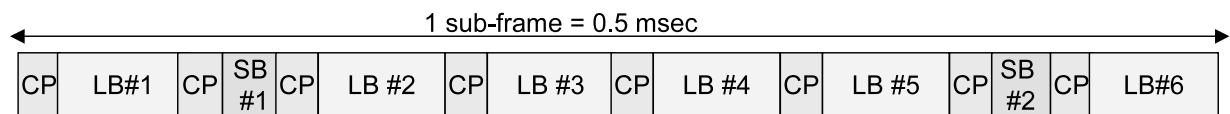

Figure 2.7: Sub-frame structure in time domain

As we see from Figure 2.7, a sub-frame consists of two short blocks (SB) and six long blocks (LB), with CP inserted between them. In general, long blocks are used for data transmission, while short blocks are used for reference signals which are important in demodulation at the receiver. Actually, short blocks are also available for data transmission sometimes. The total time for one sub-frame is 0.5ms.

In Figure 2.8, there are always some unused subcarriers at both sides of the occupied frequency, they are considered as “guard band”.

Based on Table 2.1, when the bandwidth of transmission is 1.25/2.5/5/10/15/20 MHz, the number of subcarriers in LB is 75/150/300/600/900/1200, and the number of subcarriers in SB is 38/75/150/300/450/600, respectively. Please see [4] for more details.

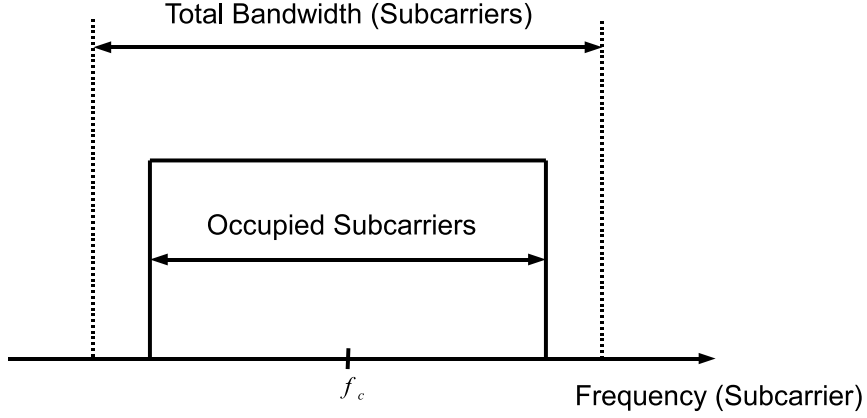

Figure 2.8: Physical Mapping of one block in RF frequency domain

Table 2.1: Parameters for Uplink Transmission Scheme

| Spectrum Allocation (MHz) | Sub-frame duration (ms) | Long block size (s/number of occupied subcarriers /samples) | Short block size (s/number of occupied subcarriers /samples) | CP duration (s/samples) |
|---------------------------|-------------------------|---|--|--|
| 20 | 0.5 | 66.67/1200/2048 | 33.33/600/1024 | $(4.13/127) \times 7$, $(4.39/135) \times 1$ |
| 15 | 0.5 | 66.67/900/1536 | 33.33/450/768 | $(4.12/95) \times 7$, $(4.47/103) \times 1$ |
| 10 | 0.5 | 66.67/600/1024 | 33.33/300/512 | $(4.1/63) \times 7$, $(4.62/71) \times 1$ |
| 5 | 0.5 | 66.67/300/512 | 33.33/150/256 | $(4.04/31) \times 7$, $(5.04/39) \times 1$ |
| 2.5 | 0.5 | 66.67/150/256 | 33.33/75/128 | $(3.91/15) \times 7$, $(5.99/23) \times 1$ |
| 1.25 | 0.5 | 66.67/75/128 | 33.33/38/64 | $(3.65/7) \times 7$, $(7.81/15) \times 1$ |

Chapter 3

System Model

Before the simulation, a system model is required. This chapter will describe the SC-FDMA system model, and the total model will be divided into two parts: “transmission model” and “channel model”. Before that, an overview of SC-FDMA will be given, and we will also introduce some principles of SC-FDMA by comparing it with OFDMA.

3.1 Overview of the SC-FDMA system

SC-FDMA, which is used in the uplink of 3GPP LTE, is a new single carrier multiple access technique, and it consists of many orthogonal carriers, each of them called a subcarrier. These subcarriers carry the symbols which are modulated by some method, such as QAM (Quadrature Amplitude Modulation) or PSK (Phase Shift Keying). The transmitter in an SC-FDMA system uses different orthogonal subcarriers to transmit information symbols sequentially.

The advantage of such a system is the ability to remove ISI (Inter Symbol Interference) between two symbols. Moreover, compared with OFDMA, which uses different orthogonal subcarriers to transmit information symbols in parallel, due to single carrier modulation at the transmitter, SC-FDMA has lower PAPR (Peak-to-Average Power Ratio), that will

reduce the energy consumption. Another advantage is that it has less sensitivity to carrier frequency offset, which brings large troubles to OFDMA.

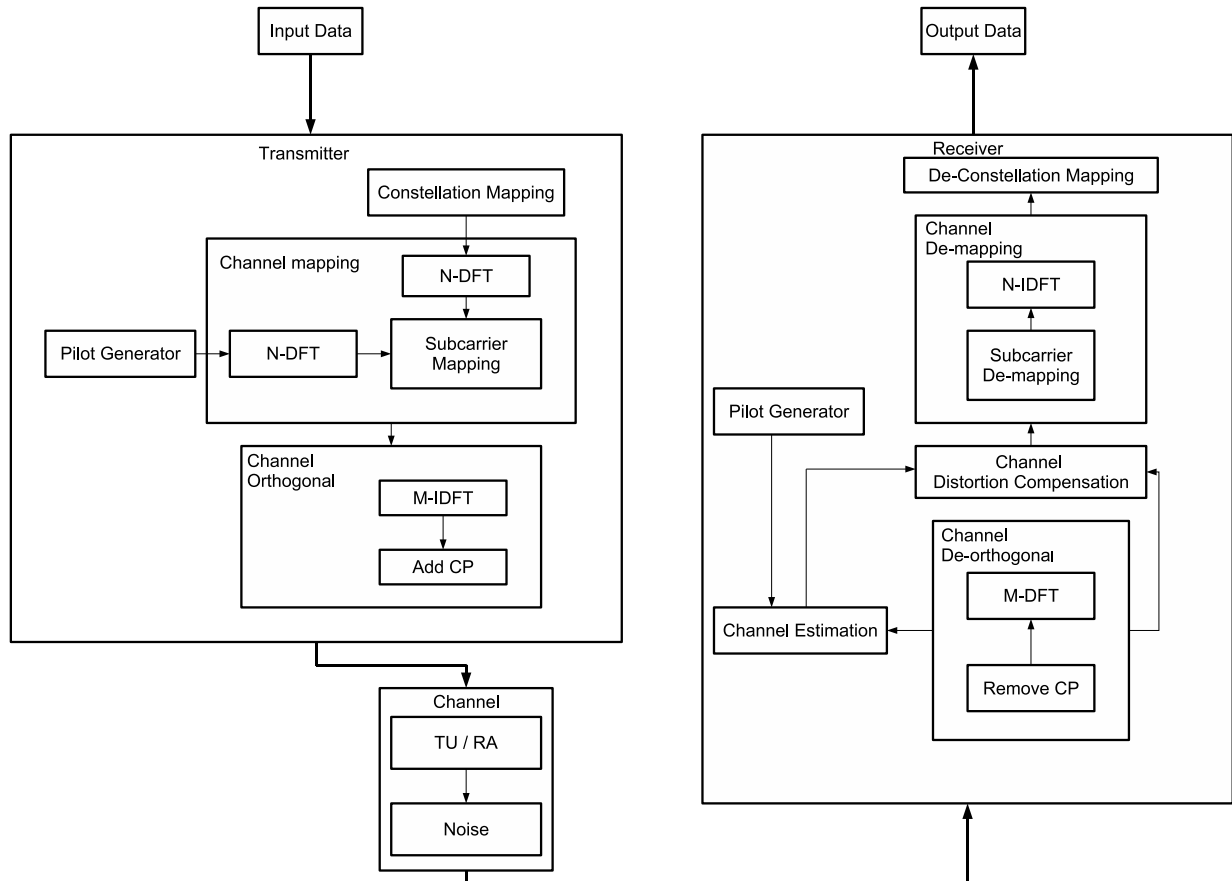

Figure 3.1: System Model

Figure 3.1 shows the procedures of system simulation. A simulation system should contain three parts: “transmitter”, “channel” and “receiver”. Here we consider “transmitter” and “receiver” as “transmission”.

3.2 Transmission model

From Figure 3.1, we see that a transmitter mainly contains constellation mapping, subcarrier mapping, and channel orthogonalization.

3.2.1 Constellation

In SC-FDMA implementation of 3GPP LTE uplink, the modulation schemes are BPSK($\pi/2$ -shifted), QPSK, 8PSK and 16QAM.

3.2.2 Subcarrier Mapping

There are two subcarrier mapping modes – Distributed mode and Localized mode, which are shown in Figure 3.2. In distributed subcarrier mapping mode, the outputs are allocated equally spaced subcarriers, with zeros occupying the unused subcarriers in between. While in localized subcarrier mapping mode, the outputs are confined to a continuous spectrum of subcarriers [2]. We refer to the distributed subcarrier mapping mode of SC-FDMA as distributed FDMA (DFDMA), and the localized subcarrier mapping mode of SC-FDMA as localized FDMA (LFDMA).

Except the above two modes, there is another special subcarrier mapping mode – Interleaved subcarrier mapping mode of SC-FDMA (IFDMA). IFDMA is a special form of DFDMA, and the only difference between DFDMA and IFDMA is that the outputs of IFDMA are allocated over the entire bandwidth, whereas the DFDMA's outputs are allocated every several subcarriers. If there are more than one user in the system, different subcarrier mapping modes give different subcarrier allocation.

Figure 3.2 shows different subcarrier allocation with 3 users, 4 subcarriers per user and 12 subcarriers in total.

This is the output symbol calculation in IFDMA in time domain. Let $m = N \cdot q + n$,

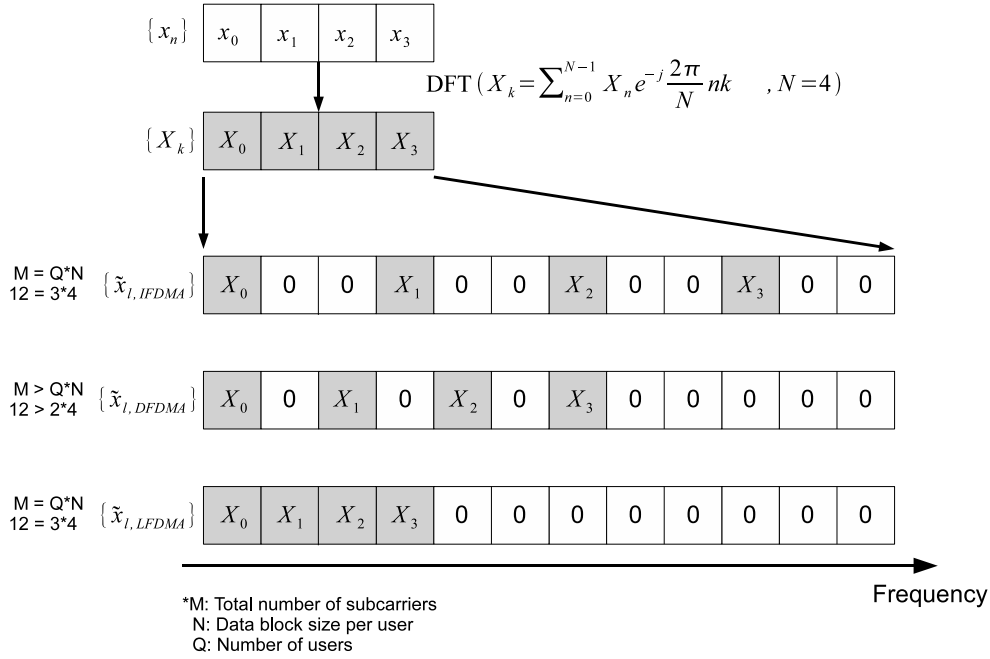

Figure 3.2: Differences among subcarrier mapping modes

$M = Q \cdot N$, where $0 \leq q \leq Q - 1$ and $0 \leq n \leq N - 1$. Then,

$$\begin{aligned}
 \tilde{x}_m (= \tilde{x}_{Nq+n}) &= \frac{1}{m} \sum_{l=0}^{M-1} \tilde{X}_l e^{j2\pi \frac{m}{M} l} \\
 &= \frac{1}{Q} \cdot \frac{1}{N} \sum_{k=0}^{N-1} X_k e^{j2\pi \frac{m}{N} k} \\
 &= \frac{1}{Q} \cdot \frac{1}{N} \sum_{k=0}^{N-1} X_k e^{j2\pi \frac{nq+N}{N} k} \\
 &= \frac{1}{Q} \cdot \left(\frac{1}{N} \sum_{k=0}^{N-1} X_k e^{j2\pi \frac{n}{N} k} \right) \\
 &= \frac{1}{Q} x_n
 \end{aligned} \tag{3.1}$$

Here is output symbol calculation in LFDMA in time domain. Let $m = Q \cdot n + q$ and $M = Q \cdot N$, where $0 \leq q \leq Q - 1$ and $0 \leq n \leq N - 1$. Then,

$$\begin{aligned}
 \tilde{x}_m &= \tilde{x}_{Qn+q} & (3.2) \\
 &= \frac{1}{M} \sum_{l=0}^{M-1} \tilde{X}_l e^{j2\pi \frac{m}{M} l} \\
 &= \frac{1}{Q} \cdot \frac{1}{N} \sum_{l=0}^{N-1} X_l e^{j2\pi \frac{Qn+q}{QN} l}
 \end{aligned}$$

If $q = 0$, then,

$$\begin{aligned}
 \tilde{x}_m &= \tilde{x}_{Qn} & (3.3) \\
 &= \frac{1}{Q} \cdot \frac{1}{N} \sum_{l=0}^{N-1} X_l e^{j2\pi \frac{Qn}{QN} l} \\
 &= \frac{1}{Q} \cdot \frac{1}{N} \sum_{l=0}^{N-1} X_l e^{j2\pi \frac{n}{N} l} \\
 &= \frac{1}{Q} x_n
 \end{aligned}$$

If $q \neq 0$, then,

$$X_l = \sum_{p=0}^{N-1} x_p e^{-j2\pi \frac{p}{N} l} \quad (3.4)$$

$$\begin{aligned}
 \tilde{x}_m &= \tilde{x}_{Qn+q} & (3.5) \\
 &= \frac{1}{Q} \left(1 - e^{j2\pi \frac{q}{Q}} \right) \cdot \frac{1}{N} \sum_{p=0}^{N-1} \frac{X_p}{1 - e^{j2\pi \left\{ \frac{(n-p)}{N} + \frac{q}{QN} \right\}}}
 \end{aligned}$$

From Figure 3.2 and the equations above, we can explain why interleaved subcarrier mapping mode is a desirable choice. In IFDMA, according to eq. (3.1), every output symbol is simply a repeat of input symbol in time domain. Therefore, the IFDMA signal has the same PAPR as conventional single carrier signal. But in LFDMA, from eq. (3.3), the output signal has exact copies of input time symbols in the N-multiple sample positions, while according to eq. (3.5), other subcarriers are occupied by complex-weighted sums of all input symbols, which will increase the amount of calculation.

3.2.3 Pilot insertion

Pilot is a kind of reference signal, which is important to the estimation of outputs. In the 3GPP LTE uplink application, there are two types of blocks in each subframe – long blocks and short blocks. The long blocks are used for control and/or data transmission, while the short blocks can be used for either control/data transmission or reference signals, which is a so-called “pilot”. In this master thesis, we assumed that the short blocks are only used for pilot transmission. A number of pilots will increase the accuracy of estimation, but it

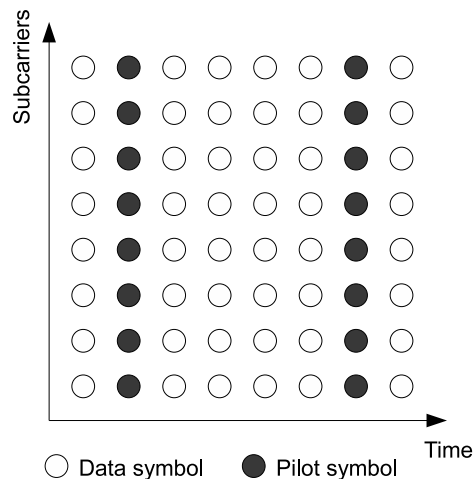

Figure 3.3: Positions of data and pilot

will decrease the efficiency, because there isn't any new information in the pilot symbols.

3.3 Channel Model

In a wireless communication system, the transmitted signal always suffers from fading, which can occur both in large scale and small scale. Large-scale fading is caused by path loss and shadowing, and small-scale fading is due to the constructive and destructive interference of multipath signals [1]. In this section, we will introduce some necessary knowledge about the channel model between the transmitter and the receiver, and we divide it into two parts – fading channel and noise.

3.3.1 Characteristics of the Fading Channel

A suitable channel model should be chosen, in order to make the simulation as close to the reality as possible. There are many channel models, such as Rayleigh channel and Rician channel.

According the document from 3GPP [8], in the mobile environment, radio wave propagation can be described by multiple paths which arise from reflection and scattering. If there are N distinct paths from the transmitter to the receiver, the impulse response for this channel will be:

$$h(\tau) = \sum_i^N a_i \delta(\tau_i) \quad (3.6)$$

which is the well known tapped-delay line model. Due to the scattering, each path will be the result of the addition of a large number of scattered waves with approximately the same delay, that gives rise to time-varying fading of the path amplitudes a_i , a fading which is well described by Rayleigh distributed amplitudes varying according to a classical Doppler

spectrum:

$$S(f) \propto 1/(1 - (f/f_D)^2)^{0.5} \quad (3.7)$$

Table 3.1: Default mobile speeds for the channel models

| Channel Model | Model Speed |
|---------------|-------------|
| TUx | 3Km/h |
| | 50Km/h |
| | 120Km/h |
| RAx | 120Km/h |
| | 250Km/h |
| HTx | 120Km/h |

Table 3.1 and Table 3.2 are both the standards of 3GPP LTE. Table 3.1 gives the standard velocities for which the estimations are carried out, and Table 3.2 presents the characteristics of the channel model in a typical urban environment.

3.3.2 Noise addition

To make the channel as close to the reality as possible, noise should be added. In a system, noise is usually measured by SNR (Signal to noise ratio), which is defined as the the ratio of the received signal power P_r to the power of noise within the bandwidth of the transmitted signal $s(t)$. Since white Guassian noise has uniform power spectral density(PSD) $N_0/2$, and the total bandwidth is $2B$, the received SNR is given by

$$SNR = \frac{P_r}{N} = \frac{P_r}{N_0/2 \cdot 2B} = \frac{P_r}{N_0B} \quad (3.8)$$

Table 3.2: Typical Urban channel model (TUx)

| Tap number | Relative time (s) | average relative power (dB) | doppler spectrum |
|------------|-------------------|-----------------------------|------------------|
| 1 | 0 | -5.7 | Class |
| 2 | 0.217 | -7.6 | Class |
| 3 | 0.512 | -10.1 | Class |
| 4 | 0.514 | -10.2 | Class |
| 5 | 0.517 | -10.2 | Class |
| 6 | 0.674 | -11.5 | Class |
| 7 | 0.882 | -13.4 | Class |
| 8 | 1.230 | -16.3 | Class |
| 9 | 1.287 | -16.9 | Class |
| 10 | 1.311 | -17.1 | Class |
| 11 | 1.349 | -17.4 | Class |
| 12 | 1.533 | -19.0 | Class |
| 13 | 1.535 | -19.0 | Class |
| 14 | 1.622 | -19.8 | Class |
| 15 | 1.818 | -21.5 | Class |
| 16 | 1.836 | -21.6 | Class |
| 17 | 1.884 | -22.1 | Class |
| 18 | 1.943 | -22.6 | Class |
| 19 | 2.048 | -23.5 | Class |
| 20 | 2.140 | -24.3 | Class |

As we see from Figure 3.4 (calculated in the simulation part), the channel gain of the model is changed as the time and frequency increase.

3.4 Model structure settings

The general model structure settings are presented in Table 3.3.

As seen in Table 3.3, 20MHz is the only frequency used in the simulations, and the parameters of model structure are determined according to [4].

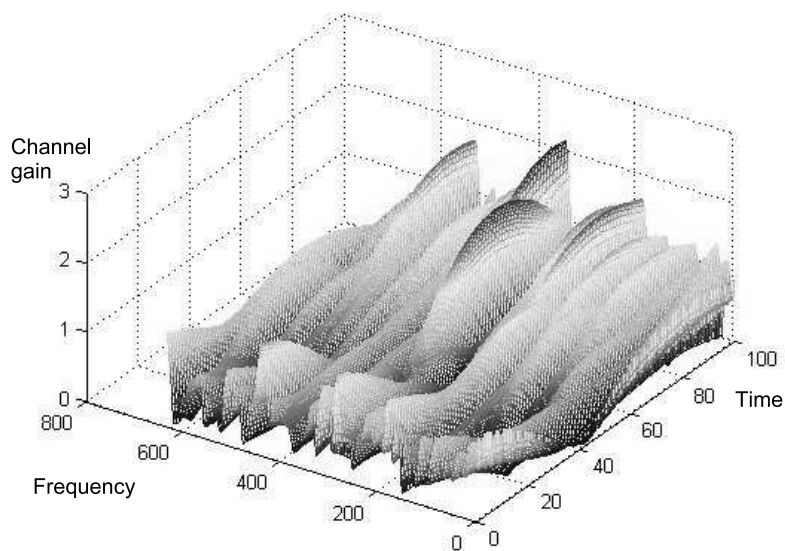

Figure 3.4: Channel model

Table 3.3: Structure settings in simulation

| The Name of Parameters | Values |
|---------------------------------------|----------|
| Carrier frequency | 20MHz |
| Subcarriers in each long block | 1200 |
| Subcarriers in each short block | 600 |
| Guardband in each long block | 80 |
| Guardband in each short block | 40 |
| Pilot Subcarriers in each short block | 200 |
| Pilot Subcarriers in each long block | 0 |
| Data Subcarriers in each short block | 0 |
| Data Subcarriers in each long block | 400 |
| Frame duration | 0.5ms |
| Length of CP in short blocks | 128 |
| Length of CP in long blocks | 256 |
| Long block symbol period | 66.67e-6 |
| Short block symbol period | 33.33e-6 |
| Number of users | 3 |

Chapter 4

Channel estimation

In this chapter, several different methods of channel estimation will be introduced. Generally, there are 3 kinds of estimators – 1D estimator, 2D estimator and adaptive estimator.

4.1 1D estimator

The purpose of a 1D estimator is to estimate unknown data by reference data in one dimension, either time or frequency. There are some 1D estimators in frequency domain.

4.1.1 Least Square (LS) channel estimator

The LS estimator is a basic 1D channel estimator, which is described in [10] and [11]. We assume that all the subcarriers on short blocks are occupied by pilots, and we set d as a group of pilot symbols.

$$\mathbf{d} = \begin{bmatrix} d(0) \\ d(1) \\ \vdots \\ d(N-1) \end{bmatrix} \quad (4.1)$$

D is a matrix with the elements of d on its diagonal.

$$\mathbf{D} = \begin{bmatrix} d(0) & \dots & 0 \\ \vdots & \ddots & \vdots \\ 0 & \dots & d(N-1) \end{bmatrix} \quad (4.2)$$

An LS estimator is trying to find the channel impulse response \hat{h}_{LS} that minimizes the square error

$$\epsilon = \left| y - DW_N \hat{h}_{LS} \right|^2 \quad (4.3)$$

$$\hat{h}_{LS} = \arg_{\hat{h}_{LS}} \min (y - DW_N \hat{h}_{LS})^H (y - DW_N \hat{h}_{LS}) \quad (4.4)$$

where W_N is the DFT matrix, and y is the received signal. In order to minimize ,

$$\hat{h}_{LS} = QW_N^H D^H y \quad (4.5)$$

where

$$Q = (W_N^H D^H D W_N)^{-1} \quad (4.6)$$

This expression can be transferred to the frequency domain by taking the DFT of \hat{h}_{LS}

$$\hat{H}_{LS} = W_N \hat{h}_{LS} = W_N Q W_N^H D^H y \quad (4.7)$$

Putting eq. (4.6) into eq. (4.7), we get,

$$\hat{H}_{LS} = \bar{D}^{-1} \bar{y} \quad (4.8)$$

For those blocks where the pilots are allocated over the whole space of subcarriers at a time, the LS channel estimation in frequency domain simplifies to divide the Fourier transformed received symbols with known transmitted pilot symbols.

However, in long blocks there is no reference symbols at all, so some kinds of interpolation is required, which will be investigated later in this chapter.

Since there is no other symbols in short blocks except pilots, frequency interpolation can be skipped. Figure 4.1 shows how the estimator works with interpolation in time domain.

4.1.2 Finite Impulse Response (FIR) interpolation algorithm

This method is a modified form of Least square method. The main idea is to assume that the channel impulse response has a number of taps. From the reference data in pilot subcarriers, we can estimate these taps, and the frequency response will be achieved by doing a DFT upon them.

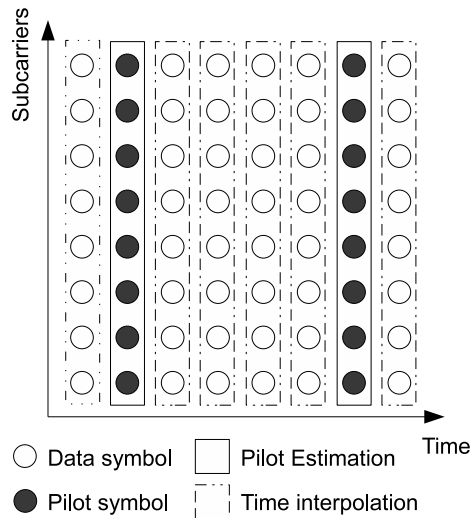

Figure 4.1: Pilot estimation and interpolation

The method of LS is described in section 4.1.1. Eq. (4.7) shows the channel frequency response of LS estimator.

Assume that the channel impulse response h has no more than L taps. Let W_P be a matrix which only contains the first L columns of W_N . This leads to the dimension of a partial DFT matrix with dimension $N \times L$. Therefore, we can get the channel frequency response by rewriting the LS estimator

$$\begin{cases} H_{FIR\ freq} = W_P Q_P W_P^H D^H y \\ Q_P = (W_P^H D^H D W_P)^{-1} \end{cases} \quad (4.9)$$

In order to make the algorithm work correctly, some requirements should be met. First, the number of taps L won't be greater than the number of pilot symbols, which is the length of a short block in this master thesis. This is because of the fact that one can't solve more than L unknowns from L equations. Therefore, the number of taps should be selected carefully.

Once we get the information from the pilot symbols, some methods of interpolation will

be used to estimate the symbols on the other positions in time domain.

The interpolation method is the same as the LS estimation's, see Figure 4.1.

4.1.3 LMMSE estimation

LMMSE (Least minimum mean square error) estimator is another 1D estimator, it minimizes the Mean Square Error (MSE) for all linear estimators [14]. The general expression of LMMSE is described as

$$\hat{H}_{LMMSE} = R_{H_f H_f} \left(R_{H_f H_f} + \frac{\beta}{SNR} I \right)^{-1} \hat{H}_{LS} \quad (4.10)$$

where $R_{H_f H_f}$ is the correlation matrix of H , \hat{H}_{LS} is the channel frequency response in least square estimation, which is described in section 4.1.1, SNR is the average signal-to-noise ratio which is defined as in eq. (3.8), and β is modulation dependent

$$\beta = E\{|d_k|^2\} E\left\{\left|\frac{1}{d_k}\right|^2\right\} \quad (4.11)$$

where d_k is the symbol on the k th subcarrier. For QPSK modulation, β is 1.

Because all the symbols in a short block are pilots, H_f is the channel response at the pilot positions in frequency domain, which is also the whole channel in frequency domain.

$R_{H_f H_f}$ is defined as

$$R_{H_f H_f} = E[H_f H_f^H] \quad (4.12)$$

When the data on the pilot positions is estimated by LMMSE estimation, information on data positions which are in long blocks will be solved by some types of interpolation. In this case, the method which is used in LS estimation is also used in LMMSE estimation, Figure 4.1 shows that.

4.1.4 Gauss-Markov estimation

By the definition in [14], the Gauss-Markov estimator has the lowest Mean Square Error (MSE) among the linear unbiased estimators. The expression of Gauss-Markov estimator is given by

$$Q_f^{GM} = W_N (W_P^H D^H D W_P)^{-1} \times W_P^H D^H \quad (4.13)$$

where W_N is the DFT matrix, W_P is the matrix which contains the first L columns of W_N , and D is a matrix with the reference data on its diagonal. See section 4.1.1 and section 4.1.2 for details.

Then, we obtain the estimated channel frequency response by

$$\hat{H}_q = Q_f^{GM} Y_q \quad (4.14)$$

The existence of this estimator depends on whether the matrix W_P is full rank or not. From [14], the matrix W_P has full rank if $N > L$. On the other side, if $L + 1 > N$, the Gauss-Markov estimator does not exist. When $N = L + 1$, the estimator simplifies to

$$Q_f^{GM} = W_N W_P^{-1} D^{-1} \quad (4.15)$$

which is equivalent to direct inversion of the system equation without noise. Figure 4.1 shows the interpolation method.

4.2 2D estimator

So far, we have introduced 4 types of estimators, all of them are 1D estimators, which means we estimate unknown data in time or frequency dimension at a time. However, the meaning of 2D estimators is to estimate unknown data from the information both in time and frequency domain simultaneously.

Investigating the structure of subcarriers in our case. In frequency domain, all the pilot

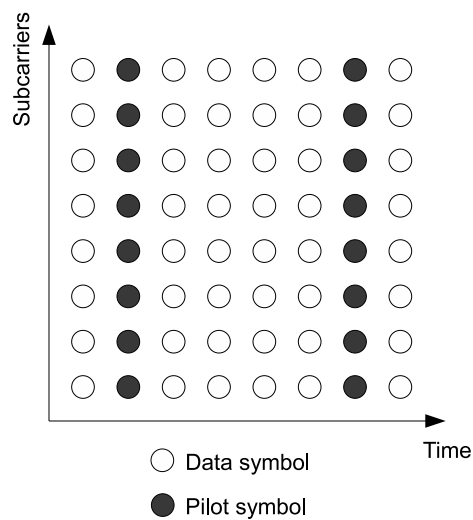

Figure 4.2: Structure of subcarriers in one frame

symbols in short blocks are known, the next step is to interpolate unknown data from two pilot symbols at the same frequency. Hence, 2D estimators are not necessary in our case, it will give the same result as 1D estimators, but having higher complexity.

4.3 Adaptive estimator

Some calculations of the above channel estimators require knowledge of channel correlations $R_{H_f H_f}$. Moreover, the statistics of channels in real world change over time. To avoid these drawbacks, we introduce the adaptive estimator which is able to update parameters of the estimator continuously, so that knowledge of channel and noise statistics are not required. In this section, we will investigate the Normalized Least Mean Square (NLMS) algorithm used in an adaptive estimator.

4.3.1 LMS algorithm

Before introducing NLMS algorithm, a brief overview of Least mean square (LMS) algorithm will be given.

LMS algorithm also can be used in an adaptive estimator, and the weight vector equation is given as

$$C(n+1) = C(n) + \frac{1}{2}\mu[-\nabla(E\{e^2(n)\})] \quad (4.16)$$

where μ is the step-size parameter, which controls the convergence of the LMS algorithm, and $e^2(n)$ is the mean square error between the beamformer output $Y(n)$ and the reference data $d(n)$

$$e^2(n) = [d^*(n) - C^h X(n)]^2 \quad (4.17)$$

The gradient vector in eq. (4.16) can be computed as

$$\nabla_C(E\{e^2(n)\}) = -2r + 2RC(n) \quad (4.18)$$

Where r and R are covariance matrices

$$r(n) = d^*(n)X(n) \quad (4.19)$$

$$R(n) = X(n)X^h(n) \quad (4.20)$$

Hence, the update weight can be given by the equation as

$$\begin{aligned} C(n+1) &= C(n) + \mu X(n)[d^*(n) - X^h(n)C(n)] \\ &= C(n) + \mu X(n)e^*(n) \end{aligned} \quad (4.21)$$

When $n = 0$, $C(0)$ can be initiated with an arbitrary value. However, a proper initial value will lead to a fast estimation. We will use

$$C(0) = [1 \ 0 \ \dots \ 0]^T \quad (4.22)$$

4.3.2 NLMS algorithm

The NLMS (Normalized Least Mean Square) algorithm is a developed solution based on the LMS algorithm. We use the NLMS algorithm rather than the LMS algorithm because the choice of the step-size parameter μ is simpler.

$$C(n) = C(n-1) + \frac{\mu}{\|X(n-1)\|^2} e^*(n) X(n-1) \quad (4.23)$$

where $\|X(n-1)\|^2 = \sum_{i=0}^{M-1} |X(n-1-i)|^2$. Then the estimated channel taps are

$$Y(n) = C^h(n) X(n) \quad (4.24)$$

The requirement for stable operation of the NLMS algorithm is $0 < \mu < 2$, the choice of μ is a trade-off between the convergence speed, and an excessive MSE (mean square error). By testing, we obtained good results when $\mu \approx 0.05$.

4.4 Estimator summary

4.4.1 1D estimator

There are four types of 1D estimators introduced. They are the LS estimator, the FIR algorithm, the LMMSE estimator, and the Gauss-Markov estimator. The LS estimator is one of the most simple and common estimators. The FIR algorithm refers to a number of taps which lead to the estimated frequency response. The LMMSE estimator minimizes the MSE for all the linear estimators, and it requires the frequency response of the LS estimation. The Gauss-Markov estimator has the lowest MSE among the linear unbiased estimators.

4.4.2 2D estimator

As we analysed in section 4.2, the 2D estimator is not suitable for this case, so it is skipped.

4.4.3 Adaptive estimator

The adaptive estimator can change the parameters over time as channel statistics change. It has larger complexity than the 1D estimators. We investigate NLMS algorithm as an adaptive estimator.

Chapter 5

Simulations

5.1 The test case

When a system is simulated, there are many parameter configurations related to the final results. However, in order to save time, we specify some certain test cases to show the characteristics of the system.

According to [4], the studied uplink data-modulation schemes in 3GPP LTE are BPSK($\pi/2$ -shifted), QPSK, 8PSK and 16QAM. However, the results of the simulation are only presented under QPSK modulation, since the other modulation schemes can not give any more benefit to the performance of the estimators. The SNR is within 0 – 40dB. The simulations are carried out at three speeds – 3km/h, 50km/h and 120km/h. In order to get good average results, all the simulations are done for 2000 frames.

The purpose of the simulations is to find the type of estimator that gives the best performance with different SNR levels and speed.

A summary of settings for the simulations is given in Table 5.1.

Table 5.1: Settings for the simulations

| | | | |
|--------------|-------------|--------|---------|
| Velocity | 3km/h | 50km/h | 120km/h |
| Channel taps | 20 taps | | |
| Modulation | QPSK | | |
| SNR | 0–40 dB | | |
| Simulations | 2000 frames | | |

5.2 Results and analysis

5.2.1 Simulation results

The simulations are carried out according to the Table 3.3 and Table 5.1, and give the symbol error rate as a function of SNR. (In order to be able to read the figures, the plotting of the results are divided into two parts)

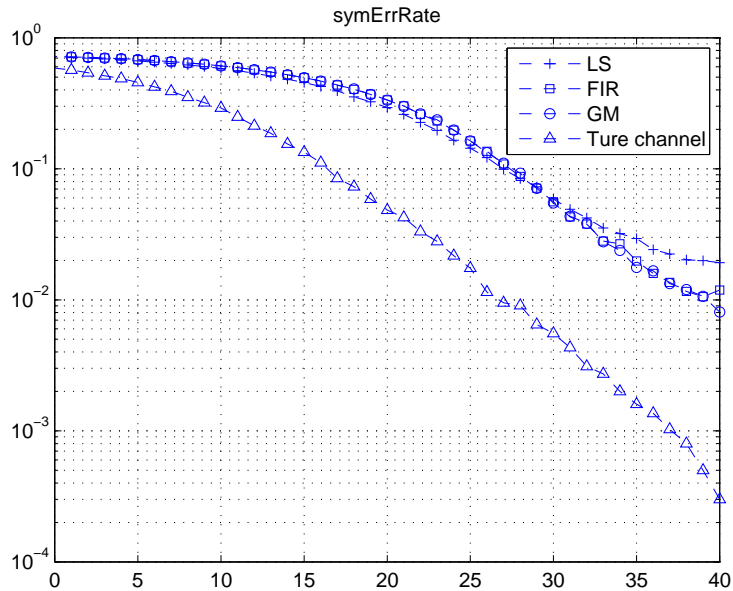

Figure 5.1: Simulation result under 3km/h (Part1)

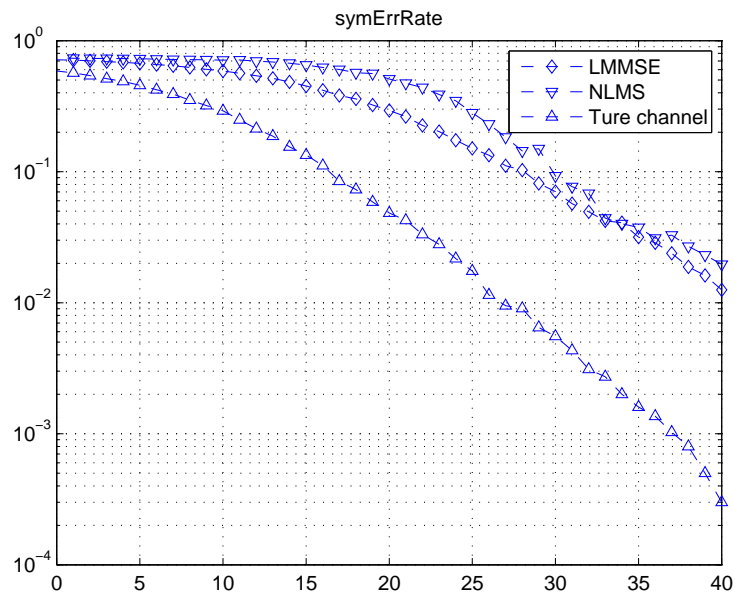

Figure 5.2: Simulation result under 3km/h (Part2)

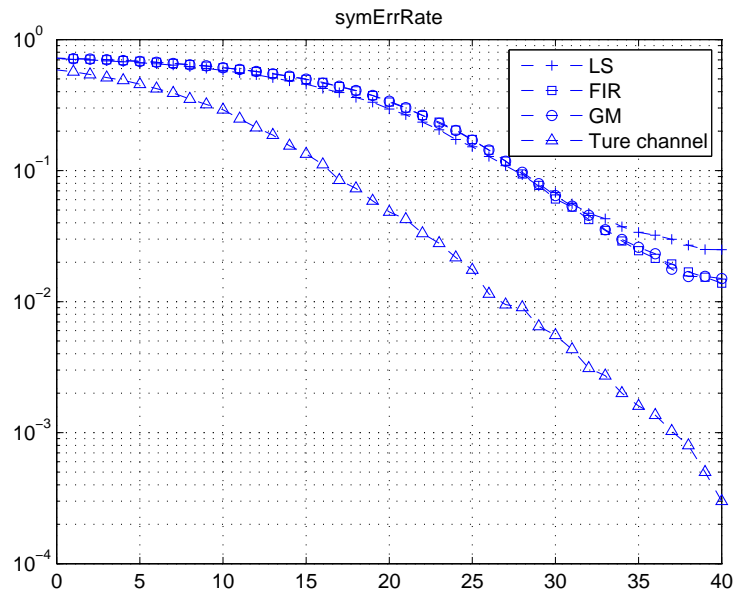

Figure 5.3: Simulation result under 50km/h (Part1)

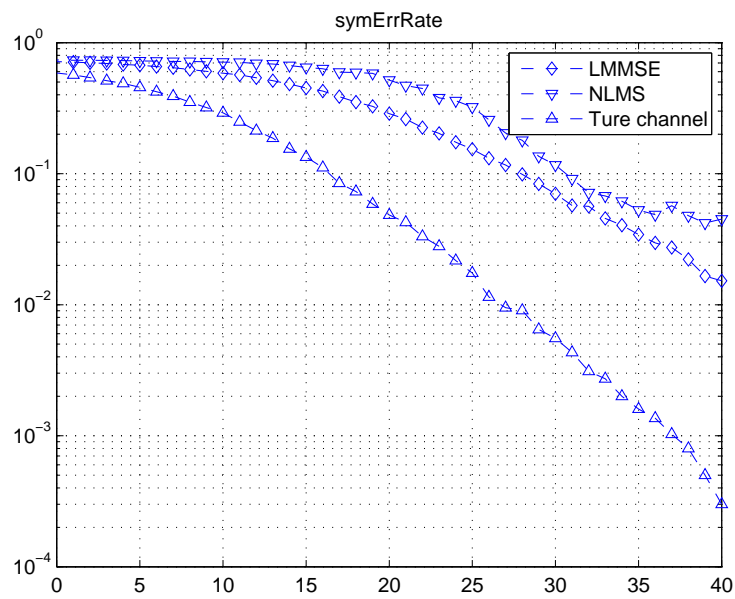

Figure 5.4: Simulation result under 50km/h (Part2)

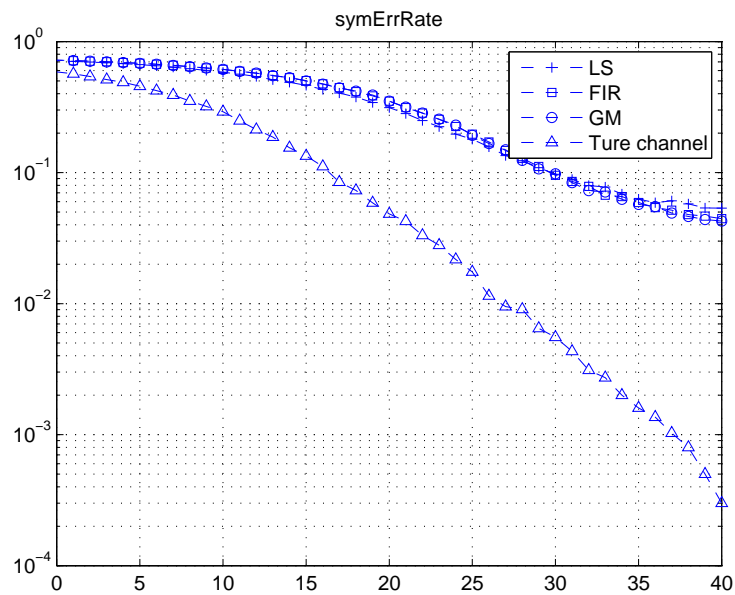

Figure 5.5: Simulation result under 120km/h (Part1)

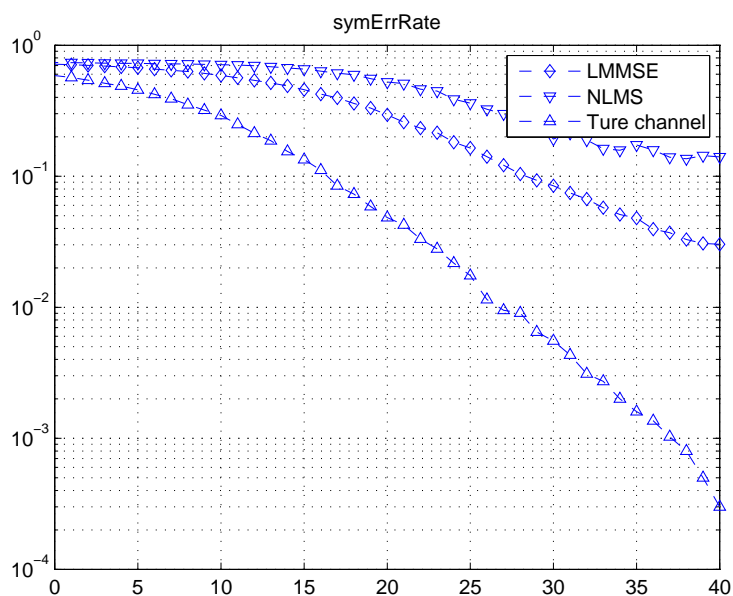

Figure 5.6: Simulation result under 120km/h (Part2)

Figure 5.1 and Figure 5.2 show the simulation results under 3km/h, Figure 5.3 and Figure 5.4 show the simulation results under 50km/h, Figure 5.5 and Figure 5.6 show the simulation results under 120km/h.

5.2.2 Analysis

According to Figure 5.1 – Figure 5.6, it is hard to say which estimator is the best one. As can be seen, the differences between some of the estimators are pretty small.

Each of estimators has its own special advantages and disadvantages. For the results under 3km/h, the LMMSE estimator gives the best performance in low SNR condition, but the Gauss-Markov estimator is the best in high SNR condition.

The results under 50km/h are similar with the results under 3km/h, the LMMSE and the Gauss-Markov estimator give best performances in low and high SNR conditions, respec-

tively.

Under 120kn/h, the LMMSE estimator has the best result both in low and high SNR condition.

As we see from the results, the final performance is affected not only by the type of channel estimator, but also by the applied velocity, that means a high velocity gives a worse transmission performance. Obviously, speed has less effect on the LMMSE estimator, or the other estimators loose more performance with high speed.

Another key point is the simulation time. It is affected by the complexity of the channel estimators. Table 5.2 shows the time consumption for each estimation method measured over 2000 frames. As we see from Table 5.2, the LMMSE estimator needs the shortest time, and the FIR estimator needs the longest time.

Table 5.2: Time consumption of estimation methods

| Channel estimator | Time consumption (min) |
|-------------------|------------------------|
| LS | 561 |
| FIR | 749 |
| Gauss-Markov | 658 |
| LMMSE | 468 |
| NLME | 560 |

Taking into account both the results for different speeds and the time consumptions, the LMMSE estimator is the best choice in high speed environment, and the Gauss-Markov estimator is the best solution in low speed environment, as well as the LS estimator. Although the FIR has a good performance in simulation, it needs the longest time.

Chapter 6

Conclusions and Future work

This master thesis has investigated several different channel estimators in an SC-FDMA system. The parameters are set according to the standard of 3GPP LTE. The investigated estimators are LS estimator, FIR estimator, Gauss-Markov estimator, LMMSE estimator and NLMS estimator.

In order to analyse these channel estimators, an SC-FDMA system is required. In this thesis, we have built a system model in MATLAB, dividing the model into a transmitter, channel, and receiver part.

In an SC-FDMA system, there are two steps for a channel estimator, first to estimate the pilot symbols, and second to interpolate the channel over the pilot symbols.

The final performance is affected not only by the type of channel estimator, but also by the applied velocity. A higher velocity gives a worse transmission performance.

In general, the FIR and Gauss-Markov estimators give almost the same good performance. However, FIR algorithm has a high complexity, which will need longer simulation

time. For high velocities, the LMMSE estimator gives the best result, and also actually needs the shortest simulation time.

Further interesting work

- Finding good solutions to decrease the difference between transmitted data and received data.
- Studying the same estimators and find differences when we change the structure of the frame. E.g. by allocating the pilot symbols over the whole frame.
- Studying other interpolation methods to decrease the Symbol Error Rate.

References

- [1] Andrea Goldsmith, “Wireless Communications”, Cambridge University Press, 2005
- [2] Hyung G.Myung, “Single Carrier Orthogonal Multiple Access Technique for Broadband Wireless Communication”, Polytechnic University, January 2007
- [3] Hyung G.Myung, “Technical Overview of 3GPP Long Term Evolution (LTE)”, <http://hgmyung.googlepages.com/3gppLTE.pdf>, Feb.8, 2007
- [4] 3GPP, “Technical Specification Group Radio Access Networks Physical layer aspects for evolved Universal Terrestrial Radio Access (UTRA)”, 3GPP, Technical Specification TR 25.814 V7.1.0 Sep. 2006, Release 7
- [5] Hyung G.Myung, “Single Carrier FDMA”, <http://hgmyung.googlepages.com/SCFDMA.pdf>, November 2007
- [6] Hyung G.Myung, Junsung Lim, and David J.Goodman, “Single Carrier FDMA for Uplink Wireless Transmission”, 1556-6072/06/20.00©2006 IEEE, IEEE VEHICULAR TECHNOLOGY MAGAZINE I SEPTEMBER 2006
- [7] David Falconer, S. Lek Ariyavisitakul, Anader Benyamin-Seeyar, Brian Eidson, “Frequency Domain Equalization for Single-Carrier Broadband Wireless Systems”, Communications Magazine, IEEE, Apr. 2002

-
- [8] 3GPP, “Technical Specification Group Radio Access Networks Deployment aspects”, 3GPP, Technical Specification TR 25.943 V6.0.0 Dec. 2004, Release 6
- [9] Ye (Geoffrey) Li, Leonard J. Cimini and Nelson R. Sollenberger, “Robust Channel Estimation for OFDM Systems with Rapid Dispersive Fading Channels”, IEEE TRANSACTION ON COMMUNICATIONS, VOL 46, NO 7, July 1998
- [10] Hui Liu and Guoqing Li, “OFDM-Based Broadband Wireless Networks Design and Optimization”, ISBN 0-471-72346-0, John Wiles & Sons, Inc., 2005
- [11] Daniel Larsson, “Analysis of channel estimation methods for OFDMA”, XR-EE-KT 2006:011, Royal Institute of Technology, 2006
- [12] Kyungjin Oh, “Impact of Channel Estimation Error in Adaptive Wireless Communication Systems”, Polytechnic University, June 2006
- [13] Yushi Shen and Ed Martinez, “Channel Estimation in OFDM System”, Freescale Semiconductor, Inc., 2006
- [14] Gerhard Wunder, Chung-Shan Wang, Peter Jung, Paul A.M.Buné, Christian Gerlach, “Practical Channel Estimation Schemes for 3GPP OFDM New Air Interface”, ftp://ftp.hhi.de/jungp/publications/TechReports/ofdm.ce_techreport05.pdf, 2005
- [15] Hyung G.Myung, Junsung Lim, David J.Goodman, “Peak-To-Average Power Ratio of Single Carrier FDMA Signals with Pulse Shaping”, 1-4244-0330-8/06/\$20.00©2006 IEEE, The 17th Annual IEEE International Symposium On Personal, Indoor and Mobile Radio Communications (PIMRC’06)
- [16] Dieter Schafhuber, Gerald Matz, and Franz Hlawatsch, “Adaptive Wiener Filters For Time-varying Channel Estimation in Wireless OFDM System”, IEEE ICASSP-03 ,Hong Kong, April 2003

-
- [17] Dieter Schafhuber and Gerald Matz, “MMSE and Adaptive Prediction of Time Varying Channel for OFDM systems”, IEEE TRANSACTIONS ON WIRELESS COMMUNICATIONS, VOL.4, NO.2, MARCH 2005