

Institutionen för systemteknik
Department of Electrical Engineering

Examensarbete

**Channel Quality Information Reporting and
Channel Quality Dependent Scheduling in LTE**

Examensarbete utfört i Reglerteknik
vid Tekniska högskolan i Linköping
av

Erik Eriksson

LITH-ISY-EX--07/4067--SE

Linköping 2008



Linköpings universitet
TEKNISKA HÖGSKOLAN

Department of Electrical Engineering
Linköpings universitet
SE-581 83 Linköping, Sweden

Linköpings tekniska högskola
Linköpings universitet
581 83 Linköping

Channel Quality Information Reporting and Channel Quality Dependent Scheduling in LTE

Examensarbete utfört i Reglerteknik
vid Tekniska högskolan i Linköping
av

Erik Eriksson

LITH-ISY-EX--07/4067--SE

Handledare: **David Törnqvist**
ISY, Linköpings universitet
Eva Englund
Ericsson Research
Kristina Jersenius
Ericsson Research

Examinator: **Fredrik Gunnarsson**
ISY, Linköpings universitet

Linköping, 11 January, 2008

	Avdelning, Institution Division, Department Division of Automatic Control Department of Electrical Engineering Linköpings universitet SE-581 83 Linköping, Sweden		Datum Date 2008-01-11
	Språk Language <input type="checkbox"/> Svenska/Swedish <input checked="" type="checkbox"/> Engelska/English <input type="checkbox"/> _____	Rapporttyp Report category <input type="checkbox"/> Licentiatavhandling <input checked="" type="checkbox"/> Examensarbete <input type="checkbox"/> C-uppsats <input type="checkbox"/> D-uppsats <input type="checkbox"/> Övrig rapport <input type="checkbox"/> _____	ISBN _____ ISRN LITH-ISY-EX--07/4067--SE Serietitel och serienummer ISSN Title of series, numbering _____
URL för elektronisk version http://www.control.isy.liu.se http://www.ep.liu.se			
Titel Title Channel Quality Information Reporting and Channel Quality Dependent Scheduling in LTE Författare Erik Eriksson Author			
Sammanfattning Abstract <p>Telecommunication systems are under constant development. Currently 3GPP is working on an evolution of the 3G-standard, under the name 3G Long Term Evolution (LTE). Some of the goals are higher throughput and higher peak bit rates. A crucial part to achieve the higher performance is channel dependent scheduling (CDS). CDS is to assign users when they have favorable channel conditions. Channel dependent scheduling demands accurate and timely channel quality reports. These channel quality indication (CQI) reports can possibly take up a large part of the allocated uplink. This thesis report focuses on the potential gains from channel dependent scheduling in contrast to the loss in uplink to reporting overhead.</p> <p>System simulations show that the gain from channel dependent scheduling is substantial but highly cell layout dependent. The gain with frequency and time CDS, compared to CDS in time domain only, is also large, around 20%. With a full uplink it can still be a considerable gain in downlink performance if a large overhead is used for channel quality reports. This gives a loss in uplink performance, and if the uplink gets to limited it will severely affect both uplink and downlink performance negatively.</p> <p>How to schedule and transmit CQI-reports is also under consideration. A suggested technique is to transmit the CQI reports together with uplink data. With a web traffic model simulations show that a high uplink load is required to get the reports often enough. The overhead also gets unnecessary large, if the report-size only depends on the allocated capacity.</p>			
Nyckelord Keywords LTE, channel dependent scheduling, channel quality information, CQI,			

Abstract

Telecommunication systems are under constant development. Currently 3GPP is working on an evolution of the 3G-standard, under the name 3G Long Term Evolution (LTE). Some of the goals are higher throughput and higher peak bit rates. A crucial part to achieve the higher performance is channel dependent scheduling (CDS). CDS is to assign users when they have favorable channel conditions. Channel dependent scheduling demands accurate and timely channel quality reports. These channel quality indication (CQI) reports can possibly take up a large part of the allocated uplink. This thesis report focuses on the potential gains from channel dependent scheduling in contrast to the loss in uplink to reporting overhead.

System simulations show that the gain from channel dependent scheduling is substantial but highly cell layout dependent. The gain with frequency and time CDS, compared to CDS in time domain only, is also large, around 20%. With a full uplink it can still be a considerable gain in downlink performance if a large overhead is used for channel quality reports. This gives a loss in uplink performance, and if the uplink gets to limited it will severely affect both uplink and downlink performance negatively.

How to schedule and transmit CQI-reports is also under consideration. A suggested technique is to transmit the CQI reports together with uplink data. With a web traffic model simulations show that a high uplink load is required to get the reports often enough. The overhead also gets unnecessary large, if the report-size only depends on the allocated capacity.

Acknowledgments

First of all would I like to give a greate thanks to all the people at LinLab, Ericsson Research in Linköping. Thank you for your willingness to help, all the open doors and for all the good coffee brake discussions. It has been a pleasure to come in every morning.

A special thanks goes to my supervisors; Eva Englund, for all the great ideas, and Kristina Jersenius, for your patient and taking the time to answer all my questions about absolutely everything all the time. Thank you David Törnqvist, my supervisor at ISY, for input on this report and all the support during the work.

A special thanks to my family, for support and for showing an interest even when I am floating of into detailed speculations you know nothing about. Finally I send a big thank-you to you, Tilda. For your patient proofreading, correcting the same grammar errors over and over, but mostly for just being the wonderful person you are.

Linköping, January 2008
Erik Eriksson

Abbreviations

3GPP	The Third Generation Partnership Project
ACK	Acknowledge
AMC	Adaptive Modulation and Coding
ARQ	Automatic Repeat Request
BE	Best Effort
BER	Bit Error Rate
BLER	Block Error Rate
CDF	Cumulative Distributive Function
CDS	Channel Dependent Scheduling
CQI	Channel Quality Indicator
DFT	Discrete Fourier Transform
f_D	Doppler shift
FEC	Forward error correction
FDD	Frequency Division Duplex
FDMA	Frequency Division Multiple Access
FFT	Fast Fourier Transform
GIR	Gain to Interference Ratio
GSM	Global System for Mobile Communications
HARQ	Hybrid Automatic Repeat Request
HSPA	High-Speed Packet Access
ICI	Inter Carrier Interference
IFFT	Inverse Fast Fourier Transform
IP	Internet Protocol
LTE	Long Term Evolution
MIMO	Multiple Input Multiple Output
NACK	Negative Acknowledge
OFDM	Orthogonal Frequency Division Multiplexing
OFDMA	Orthogonal Frequency Division Multiple Access
PAPR	Peak to Average Power Ratio
PDCCH	Physical Downlink Control Channel
PDSCH	Physical Downlink Shared Channel
PUCCH	Physical Downlink Control Channel
PUSCH	Physical Downlink Shared Channel
QAM	Quadrature Amplitude Modulation
QoS	Quality of Service

QPSK	Quadrature Phase Shift Keying
RACH	Random Access Channel
RLC	Radio Link Controller
RMSE	Root Mean Square Deviation
RR	Round Robin
SAE	System Architecture Evolution
SC-FDMA	Single Carrier Frequency Division Multiple Access
SIR	Signal to Interference Ratio
SINR	Signal to Interference and Noise Ratio
SNR	Signal to Noise Ratio
T_c	Coherence time
T_d	Delay spread
TCP	Transmission Control Protocol
TDD	Time Division Duplex
TTI	Transmission Time Interval
UE	User Equipment
VoIP	Voice over IP
W_c	Coherence bandwidth
WCDMA	Wideband Code Division Multiple Access

Contents

1	Introduction	1
1.1	Thesis Problem Statement	1
1.2	Method	2
1.3	Scope	2
1.4	Outline	2
2	Radiocommunication Theory	5
2.1	Radio channels	5
2.2	Radio channel models	5
2.2.1	Frequency correlation	7
2.2.2	Time correlation	7
2.2.3	Models	10
2.3	Antennas	11
2.4	Modulation	12
2.5	OFDM	12
2.6	SC-FDMA	15
2.7	Channel coding	17
2.8	Error Detection, HARQ	19
2.9	Multi-Antenna Systems, MIMO	19
2.10	Channel dependent scheduling	20
2.11	Channel Quality Estimation	21
3	Long Term Evolution	25
3.1	System design	25
3.2	Link adaptation	27
3.3	CQI-Compression	27
3.3.1	Scanning	28
3.3.2	Best-M	28
3.4	CQI-Transmission	28
4	System Evaluation Methods	31
4.1	System Simulator	31
4.2	Deployment	32
4.3	Propagation	33
4.4	Scheduling and Limitations	35

4.5	Web traffic model	37
4.6	Expected Results	37
5	Simulations	39
5.1	Load Test	39
5.2	Scheduler Test	43
5.3	Delay Test	43
5.4	Error Sensibility	46
5.5	Frequency granularity test	48
5.6	Best M test	49
5.7	Limited uplink channel test	50
5.8	Triggers and load test	52
6	Discussion	57
6.1	Conclusions	57
6.2	Future work	58
6.3	Final note	59
	Bibliography	61

Chapter 1

Introduction

I just wondered how things were put together.

Claude E. Shannon

1.1 Thesis Problem Statement

A technique to better utilize the available spectrum in telecommunication systems is to implement adaptive modulation and coding (AMC) and channel dependent scheduling (CDS). AMC is to select an communication format with coding and modulation to fit the channel quality. CDS is to assign a user the portion of the channel where it has good reception compared to all other users. The performance gain of this has shown to be high, 40-60%, [17], [22]. One of the major problems with CDS is that good channel knowledge is required for all users. This is hard to archive in a wireless system within a moving environment, due to the constant changing of the channel. In a cellular system one can get a reasonable good knowledge of the transmission properties by measurements by the users and constant reporting the result to the base station. But the resulting upload overhead can become unreasonably large, especially if the reporting interval is short. How often the channel quality needs to be reported also depends on outside factors such as user movement speed.

The next potential mobile telephony standard; 3G LTE (Long Term Evolution), from 3GPP, [1], intend to use both AMC and CDS. To be able to fully take advantage of this, a reporting mechanism from user equipment (UE) to base station will be standardized.

It is the purpose of this thesis to evaluate the gains of two different compression methods for reporting channel quality (CQI-reporting). They are referred to as Scanning and Best-M. Scanning, taking advantage of channel frequency correlation, clumps consecutive portions of the spectra and only reports the quality of each clump. Best-M on the other hand points out the best bands, since they are more likely to be scheduled, and reports the quality of those. The thesis will also attempt to find an approximate limit on how large uplink overhead that is reasonable when considering the gain in downlink throughput versus the loss

of uplink maximal throughput. The reporting interval required for good system performance will also be evaluated.

1.2 Method

This thesis work aim to find a solution to the problems described in 1.1. To do this the following 6 steps will be taken.

- Book study on radio channels and channel models.
- A book study on CQI-triggering and formats, mainly 3GPP submission papers.
- Defining different test cases and CQI-reporting methods
- Implement needed changes in Java-based Radio network simulator developed at Ericsson Research
- Run simulations and measure throughput for different test cases
- Analyze results

1.3 Scope

Both FDD (frequency division duplex) and TDD (time division duplex) systems are intended for the LTE standard. This thesis only looks at the use of FDD. When using TDD the dynamics of uplink/downlink channel-access time may be different resulting in different priority between downlink capacities versus uplink overhead. Also the reporting delays will be longer. Some knowledge of the downlink can also be achieved by making measurements on the uplink when using TDD.

No "physical" control channel will be implemented with interference and error probabilities; the estimated error rate is assumed so small that it should not affect the performance at a large scale.

The scheduler used in the simulations will not be optimized for the different scenarios, but rather will a number of default schedulers be used. The schedulers do not take the age or granularity of CQI-reports into consideration when performing scheduling. This will result in less than optimal performance, but the difference between the two reporting-methods, Best-M and Scanning, will not change much because of this.

1.4 Outline

This report is sectioned as follows: First, in Chapter 2, are some underlying theory presented. Chapter 3 contains a description of the LTE-standard and a closer description of the compression schemes. In Chapter 4 the simulation scenario is identified, some expected results and some simulation specific parameters are

defined. Chapter 5 contains simulation results and Chapter 6 a discussion, some conclusions and something about further work.

Chapter 2

Radiocommunication Theory

In this section some basic telecommunication theory will be introduced, such as modulation, coding and radio channel properties. The focus of the chapter will be on techniques intended for a future LTE system.

2.1 Radio channels

Radio waves are electromagnetic waves; therefore they are affected by the same rules that apply to all such waves, like radar and visible light, described by Maxwell's equations [7]. This means attenuation, reflection, scattering and diffraction [5]. Throughout this report the focus will be on the ultra high frequency band (UHF) between 300 and 3000 MHz, since this is the band considered for mobile telephony. These frequencies give wavelengths of 1 down to 0.1 meters.

Reflection mainly occurs when a wavefront reaches an object much larger than the wavelength, like buildings and hills. A small part of the wave is reflected against all objects dependent on their electromagnetic properties, but for large objects this is the major phenomenon.

Diffraction is the bending of waves around edges leading to more than line of sight propagation. This occurs at all edges and with objects in the same dimension as the wavelength. The bending is very dependent of the frequency, at high frequencies like for visible light it is nearly none existing.

Scattering comes from waves interacting with objects smaller than a wavelength and unsmooth surfaces. When reflecting from an unsmooth surface the phase of rays will differ somewhat and the reflection angle will be spread out.

2.2 Radio channel models

When doing calculations and simulations of radio channels, true physical models are never used due to the complexity of such a setup. Calculating the reflections and scatterings from all possible objects; trees, buildings, moving cars, people, sticks and stones are just incomprehensible. When designing a system it is not even

a goal to have such a setup, since design seldom is intended for a single location, but rather for a general working concept. To model channels to validate systems a stochastic channel model is commonly used. A stochastic channel model models the workings of a real physical channel with different probabilistic distributions. Many studies have been made to make accurate models with different complexities, e.g. [16]. The radio channel is often modeled to be subjected to three different kinds of propagation phenomena; slow fading, multi-path fading and noise. [6]

The slow fading, a result of shadowing from large buildings or other distant phenomenon, affects the channel slowly, 50 to 100 meters. This is mainly due to diffraction. Slow fading also includes the signal attenuation from traveling distance. The loss from traveling distance is for a point source with spherical radiation proportional to d^{-2} , d being the distance from source to sink in vacuum. With obstacles and reflections the attenuation factor will usually be modeled to be much higher, in the range 3 to 6.

The multi-path fading (also called fast fading) comes from multi-path propagation, the radio waves taking different paths from transmitter to the receiver. This results in a received signal that is a sum of multiple signals with different delays, amplitude and phases. This models multiple reflecting waves with scattering. The multi-path fading can vary greatly over as little as a fraction of a single wavelength; only a couple of centimeters with our frequencies of interest. It also varies in frequency. When one frequency differ half a wavelength, canceling each other out, a different frequency will differ with a full wavelength, giving a positive interference. The multi-path fading depends highly on whether or not there is line of sight between sender and receiver. If there is line of sight the direct path is usually much stronger than the reflecting paths.

Noise is not really a propagation phenomenon, but has a large impact on the quality of the received signal. In a way it states how much of the received power that contains useful information. Noise is random by nature and is either internal or external. Internal noise in a receiver mainly comes from Brownian movement of particles in material. This kind of noise can be considered a white Gaussian process and its power depends on the temperature and design of the receiver. External noise can come from cosmic radiation or manmade noise from electrical equipment. In communication applications the most important kind of noise is the kind coming from other users in the same system using the same frequencies. This kind of noise is called interference. The interference is not truly random since it can be controlled by the system. A radio channels quality is usually expressed in its SINR (signal to interference and noise ratio). SINR is defined as;

$$\text{SINR} = \frac{P_t g}{I + N}$$

Here is I the interference effect, N the noise effect and P_t is the transmitted effect. The channel gain, g , is defined as;

$$g = \frac{P_r}{P_t}$$

Here is P_r the received effect from the transmitter of interest. Systems can be

defined as interference limited or noise limited depending on if I or N is the dominant factor in the SINR calculations. If the system is clearly noise or interference limited the other part can be omitted. We then talk about SNR or SIR. If only the channel quality is in consideration, and not system performance, the transmitted effect P_t can be omitted and we only look at the gain, GIR (gain to interference ratio).

2.2.1 Frequency correlation

In radio communication systems only limited frequency bands are used. If this band is small enough the otherwise frequency selective multi-path fading can be considered constant over the entire band. This is attractive since it makes reception easier. To compensate for frequency selectivity in a signal costs much in system complexity [20]. The band over which the multi-path fading is considered constant is called the coherence bandwidth. If the bandwidth of the channel is smaller than the coherence bandwidth it is called a flat fading channel, in the opposite case it is called frequency selective fading channel. The correlation bandwidth can be viewed in the time domain, by using an inverse Fourier transform, and be viewed as signal correlation in time instead. The correlation in time depends on the difference in delay between the different paths, dependent on the multi-path environment. This leads to an estimation of the correlation bandwidth, W_c , as:

$$T_d = T_{last} - T_{first}$$

$$W_c = \frac{1}{2T_d}$$

T_d is the difference in time of arrival between the first and the last significant path, commonly referred to as the delay spread, see Figure 2.1. A significant path is a path containing enough signal energy. How much energy that is enough is a question of definition, but usual used values are -10 or -20 dB of the energy in the strongest path. With the limit of 10 dB the correlation bandwidth of a regular channel is around 400 to 1600 kHz depending on the environment, numbers taken from [4]. Instead of using the actual delay spread the rms (root mean square) delay spread, σ_T , is sometimes used to calculate the coherence bandwidth. σ_T is defined as

$$\sigma_T^2 = \frac{\int_{-\infty}^{+\infty} \tau^2 \phi_h(\tau) d\tau}{\int_{-\infty}^{+\infty} \phi_h(\tau) d\tau}$$

Here ϕ_h is the intensity profile of channel, $\phi_h = E\{h(t)h(t + \tau)\}$, and its existence depends on the wide sense stationary uncorrelated scattering assumption [5]. The correlation can then be defined for example as $1/5\sigma_T$ [19].

2.2.2 Time correlation

The large difficulty with radio channels compared to wired channels is the fact that they change over time. Multi-paths change when moving, paths appear and disap-

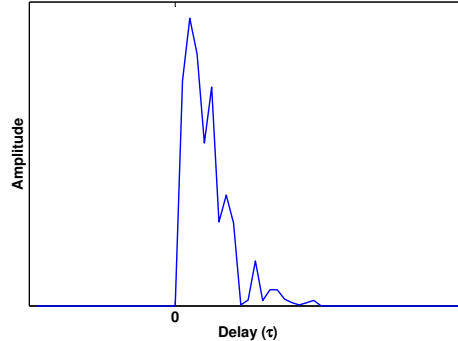

Figure 2.1. Example of possible channel time response.

pear, and like described above the interference will change to and from positive and negative dependent on relative path length. The time over which the channel can be considered constant is called the coherence time. If the symbol time, the time it takes to transmit one symbol, is longer than the coherence time the channel is called fast fading. If instead the channel coherence time is longer than the symbol time it is called slow fading. Just like with the coherence bandwidth slow fading channels are often favorable. The coherence time depends mostly on movement speed and carrier frequency. Like described above will the channel change distinctively if the different pathlength change a fraction of a wavelength. Simplified can the coherence time be defined as the time it takes to move long enough for the interference to drastically shift. The portion of a wavelength defined as giving a significant change differ within the literature, from one half down to one eight [19]. With the shift of one quarter the coherence time becomes, with a movement speed of v m/s and a carrier frequency of f_c Hz and c being the speed of light;

$$T_c = \frac{c}{4f_c v}$$

With a carrier frequency of 2 GHz and movement speed of 3 km/h, slow walking speed, the coherence time is approximately 45 ms. How fast a channel truly changes depends on the environment, but this gives an estimate.

Also with movement come Doppler effects, changes in frequency dependent on whether the receiver is moving towards or from the transmitter. The frequency shift differ for different multi-paths, a path reflecting from an object behind the receiver grows longer for a user moving towards the transmitter while the direct path of course gets shorter. This will then result in a received signal being a superposition of the sent signal modulated to a higher frequency, direct path, and a lower frequency, the growing path. The shift in frequency depends on the speed a path length changes with and is given by.

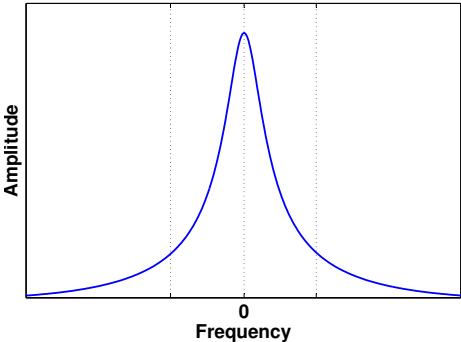

Figure 2.2. Frequency correlation of channel. Coherence bandwidth.

$$f_D = \frac{v}{c + v} f_c$$

This gives a maximal shift of ± 5.6 Hz with carrier frequency, f_c , of 2 GHz and movement speed, v , of 3 km/h. This is called the Doppler shift. The Doppler shift is proportional to the coherence time like.

$$f_D \propto \frac{1}{T_c}$$

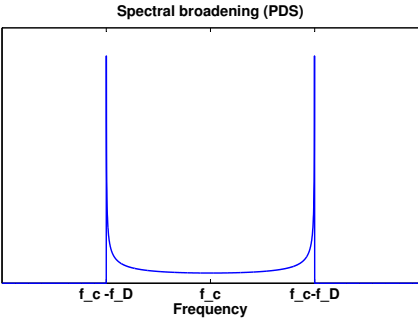

Figure 2.3. Jake’s doppler power spectrum. Assumed equal radiation from all directions.

The coherence time described above is for a channel with a bandwidth smaller than the coherence bandwidth, so the change in channel quality can be assumed

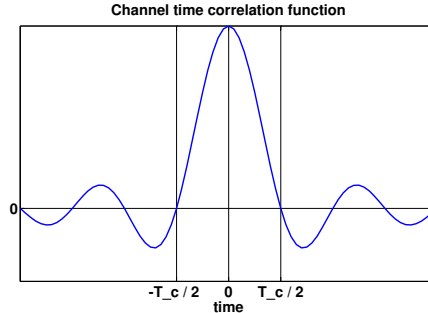

Figure 2.4. Channel time correlation.

to be similar for the entire channel. A channel with a bandwidth larger than the coherence bandwidth can be viewed as the sum of multiple independent channels with random channel quality variation. This will lead to much lower variance in the channel quality than for a small-band channel. The timescale is still approximately the same, so the channel will have a similar coherence time but will not change as much over time.

2.2.3 Models

To model the conditions of a channel one usually tries to define an environmental description like rural area or metropolitan urban area. When the area is specified a mathematical model is achieved by trying to fit a function, usually based on physical phenomenon, to measurement data. Many such models exist. One commonly used is the Okumura-Hata model;

$$L_{dB} = k + r \log(d)$$

Where the loss, L_{dB} , is the logarithm of the inverse of the channel gain and d is again the distance from transmitter to receiver. The attenuation factor r and the constant k depend on the environment. This model is popular because it is simple but still fairly accurate. This model is based on measured data made in Japan in 1968. Okumura-Hata only models the slow fading, so if a multi-path model is needed it can be added on top of this. This depends on in which timescale the channel is monitored, it is sometimes enough with only the Okumura-Hata model.

Multi-path models can be modeled as a linear time-variant filter. Multi-path comes from different paths with different delays, phase shifts and amplitude adding up to a signal. This can be modeled by delay taps with random amplitude and phase. Since all amplitudes and phase shifts can be seen as independent random variables usually a Rayleigh distribution can be used, together with a power delay

profile. The power delay profile depends highly on the environment but is commonly modeled as an exponential distribution where the mean depends on the expected delay spread. If a direct path is assumed present it will be dominant, giving rise to a Rice distribution instead of the Rayleigh. If there is line of sight between transmitter and receiver, the delay spread will usually be shorter than without line of sight.

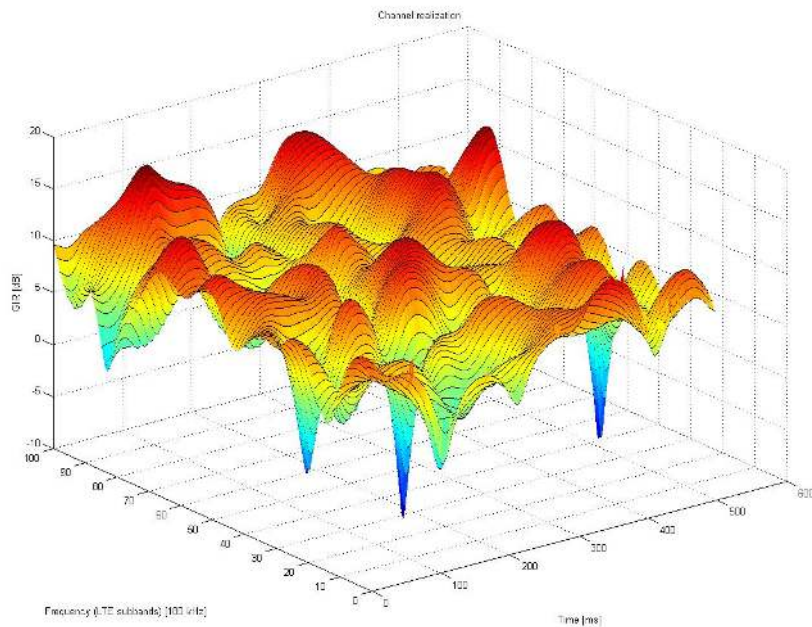

Figure 2.5. An example of a channel realization. One user in a Typical Urban environment over 0.5 s, with a bandwidth of 20 MHz at carrier frequency of 2 GHz. Speed is 3 km/h.

Sometimes, especially for indoor systems, a ray-tracing model can be considered instead of the regular random model [10]. In this case the channel quality is estimated by tracing a large number of possible paths for certain transmitter and receiver locations. This is a computationally demanding technique, especially in a moving environment, but can give more accurate models.

2.3 Antennas

To transmit and receive signals an antenna is needed. When modeling distance power loss an isotropic antenna is assumed, i.e. an antenna transmitting its power equally in all directions. This is not how a real antenna usually works. With a more directional transmitter the received power will be larger than it would have

been with an isotropic one. Therefore one talks about antenna gain, as the gain from using a directional antenna compared to using the omnidirectional one. The gain of the antenna is usually expressed as a function of the angle of departure and arrival, both horizontally and vertically. At a base station in a cellular system it is common to have antenna constellations for directional transmission. Handheld devices, like mobile phones, use isotropic antennas since they have to be able to transmit and receive to and from all directions.

2.4 Modulation

Modulation is the ability to modify a transmittable signal, carrier, so the receiver can detect the transmitted information. There are digital and analog modulations. The analog modulation, like FM and AM radio, continually modify either amplitude, AM, phase or frequency, FM, of a carrier signal. In the digital case are the transmitted data binary bits. They are transmitted in much the same way as analog data only in discrete steps. By changing amplitude and phase a decoder on the receiver side is able to detect the changes and thereby find the transmitted symbols. How to change the amplitude and phase is commonly described in a constellation diagram, for example 16-QAM (quadrature amplitude modulation) in Figure 2.6.

In Figure 2.6 are a sequences of 4 bits mapped to an inphase, I , and a quadrature, Q , values. These values correspond to real and imaginary values, giving the transmitted signal by looking at the real part after multiplying it with a complex carrier $\Re\{(I + Qi)e^{i\omega}\}$. The I - and Q -values are normalized to give an expected output effect of one. The receiver then multiplies the received signal by a cosine and a sine respectively, integrating over a period of the carrier to receive the transmitted values, Figure 2.7. The inphase and quadrature value is then mapped back to the corresponding bits. The received symbols are usually distorted, so the mapping is done to the closest point in the diagram, often with additional information about how close the demodulated symbol was to the actual constellation point.

2.5 OFDM

To gain a flat fading channel a common technique is to divide the channel into multiple sub-channels, each with a lower bandwidth and a longer symbol time (FDM, frequency division multiplex). This gives multiple flat fading channels. The different channels will not have the same fading. A problem with this technique is the inter carrier interference (ICI), one sub channel sending a portion of its effect in an adjacent sub-channel. This comes from the known fact from Fourier theory that a signal can not be limited both in time and in frequency. The ICI can be limited by adding a guard-interval between the sub channels, but this of course leads to lower spectral efficiency. Another way to counter the inter carrier interference is to cleverly space the sub channels in frequency so they are all orthogonal, Figure 2.8. This leads to multiple flat fading channels with high total spectral efficiency, practically without ICI. This method is called OFDM (orthogonal FDM).

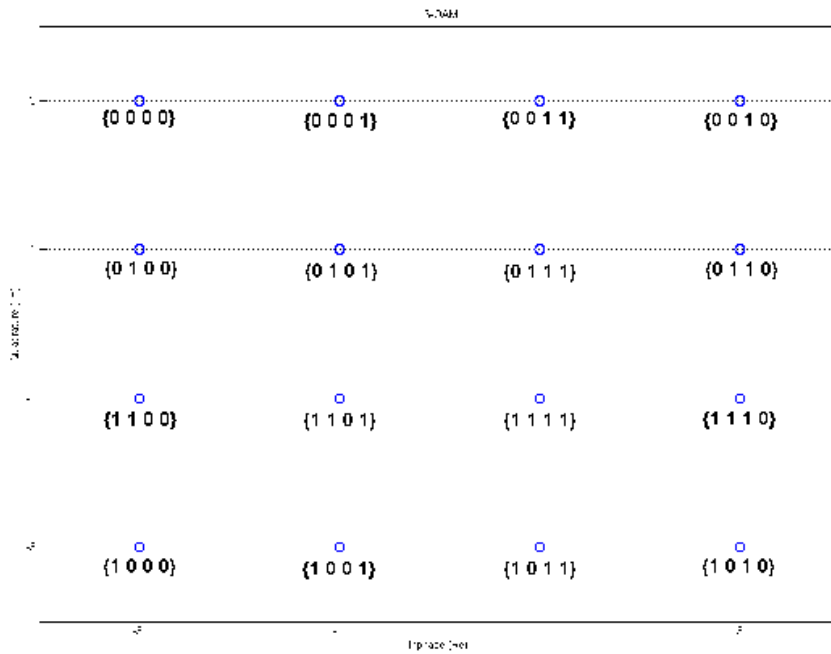

Figure 2.6. 16QAM modulation space diagram with gray-coding.

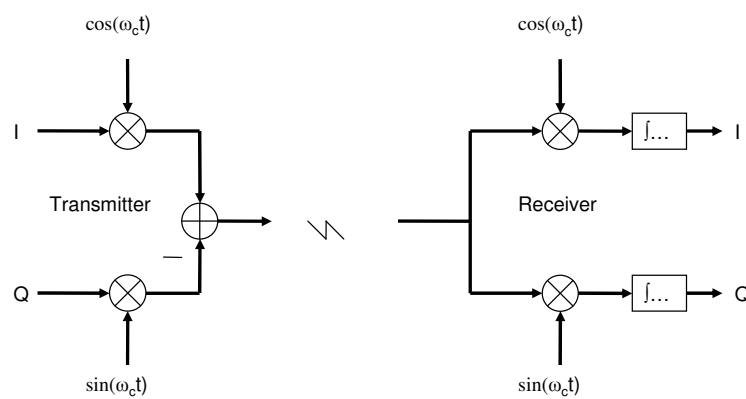

Figure 2.7. General description of a modulating system. Transmitter and receiver.

A positive effect of the frequency division, besides the flat fading, is the longer symbol time. With a symbol time considerably longer than the multi-path delay spread a cyclic prefix can be added to the signal. The cyclic prefix must be longer than the delay spread to counter inter symbol interference. To keep the overhead at a reasonable level the total symbol time should be large compared to the added portion. A cyclic prefix is a copy of the end of the symbol placed at the beginning. With this guard interval and frequency domain detection the negative affects of multi-path are almost gone [11].

An OFDM system can be implemented with effective algorithms in hardware. The mapping to orthogonal frequencies is exactly what is done in a Fourier transform. So by using an inverse Fast Fourier transform (IFFT) the sub channels can be transformed to the time-domain with an effective algorithm. On the receiver side a FFT can split the channels to the frequency domain again for detection [8].

A multi-user system with an OFDM access technique is referred to as OFDMA (orthogonal frequency division multiple access). From a frequency domain scheduling point of view does OFDMA show much potential. Technically one is able to assign each user to any sub-channel or set of sub-channels, and change the assignment after every symbol. In a wideband system, like LTE with a bandwidth up to 20 MHz, the number of sub-channels gets large leading to an unproportional signaling overhead for scheduling freely. Because of this do the scheduler usually work on chunks of sub-channels and over a longer set of time in these kinds of systems.

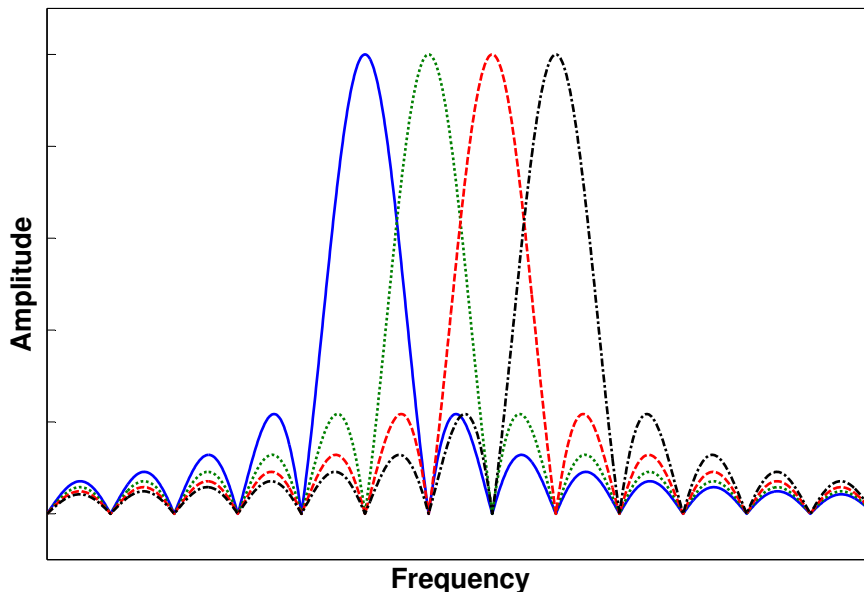

Figure 2.8. Absolute values of 4 adjacent tones in the frequency domain from an OFDM system. The sinc shape comes directly for the time limited signals.

2.6 SC-FDMA

The OFDM system described above have a few flaws. Two of them are especially troublesome in an uplink case. Firstly, it is very sensitive to small offsets in frequency losing orthogonally. This will lead to inter carrier interference. The other flaw is that the peak-to-average-power-ratio (PAPR) of an OFDM system is proportional to the number of sub channels and can grow very large for a normal sized system. PAPR is the ratio between the maximum output power and the average output power. With a high PAPR the power-amplifiers must work linearly in a wider rang, or clip the signal causing distortion and out of band radiation. Amplifiers with a large working range are more expensive and less effective. The poor efficiency is very costly for hand held devices with limited battery time [11] [15].

To counter these problems a new access technology is suggested for the LTE uplink. SC-FDMA is in short an OFDMA system with a linear precoding, often done with a DFT (discreet Fourier transform). Thanks to this precoding a single carrier characteristic is achieved leading to a more favorable power-distribution, but still keeping most of the advantages of OFDM. There are two types of SC-FDMA systems; localized and distributed. In a localized system the data is transmitted on consecutive frequencies. The output of the DFT-precoding is mapped to consecutive carriers into the IDFT (inverse discreet Fourier transform), see Figure 2.10. In a distributed system the transmitted signal is spread out in frequency. A distributed system with a constant distance between carriers spread out over the entire bandwidth is sometimes referred to as interleaved SC-FDMA. The distributed systems have lower PAPR then the localized, with the lowest PAPR for the interleaved systems. With pulse-shaping the PAPR be can lowered even more but at the expense of out of band radiation, casing interference for other users. The downside with the distributed system is that it disables frequency domain adaptive scheduling. Figure 2.9 shows an amplitude distribution for a localized SC-FDMA system, with an OFDM system as reference. With SC-FDMA a clipping threshold can be set at much lower amplitude with the same clipping-rate.

The physical implementation of a SC-FDMA system is similar to that of an OFDM-system with the only addition of a pre-coder and decoder, Figure 2.10. A SC-FDMA system adds some complexity but mainly to the receiver.

One negative part with localized SC-FDMA is that it must be scheduled in consecutive chunks, which limits the potential of channel dependent scheduling. This is not seen as a large issue for two reasons. SC-FDMA average out the SIR over the transmission bandwidth, countering spectral nulls and channel dependent scheduling demands channel knowledge. Channel knowledge comes from measuring (section 2.11) and since a user only transmits on a portion of the uplink sub-bands only the quality of those sub-bands can be calculated. Sounding techniques where users transmit reference symbols over the entire spectrum can be time multiplexed to gain better channel knowledge, but it is expensive in overhead.

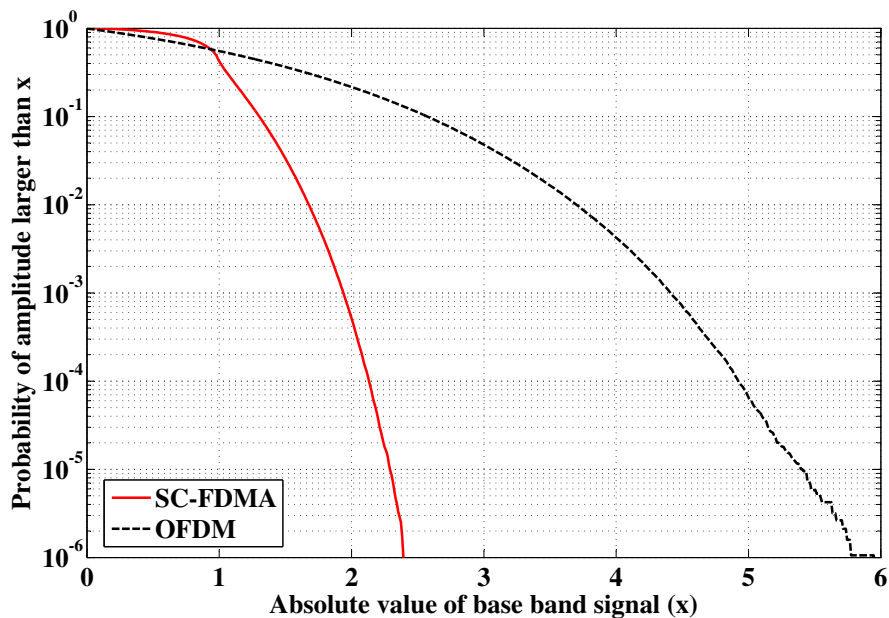

Figure 2.9. Probability of an output amplitude higher than x , for OFDM and localized SC-FDMA. Calculated for QPSK modulation with a 512 point FFT. Mean output power is 1, so mean amplitude is $1/\sqrt{2}$.

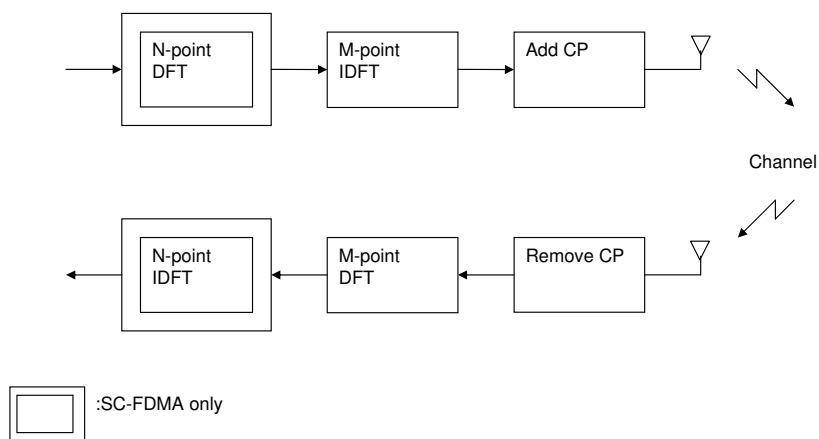

Figure 2.10. General description of an OFDM system. The SC-FDMA only differs with a DFT precoding on the transmitter side and an IDFT back-converter at the receiver side.

2.7 Channel coding

In all radio communication there will be errors, because of noise and interference. No matter how good the system is there is always a risk for a wrong detection. In digital communication systems we talk about symbol error, or more commonly, bit error ratio (BER) and block error ratio (BLER). A bit error is a transmitted bit interpreted as something else. A block is a collection of symbols, or bits, and a block is considered as received with error if one or more of its symbols are received with error. This means that for reasonably large blocks the BLER will be high even with fairly low BER. To counter this problem a forward error correction code (FEC) can be added. This means the addition of a number of bits chosen cleverly so that one with the help of these bits can detect and correct errors in the transmission. These bits are often referred to as parity-bits. There are two main classes of error correcting coding schemes, convolution codes and block codes.

A block code is a fix rate code mapping an information-word, a set of bits, to a code-word, a larger set of bits. An important subset of block codes is the linear block codes. They are important since they can be implemented by transform matrixes, giving simpler calculations.

In a convolution code a number of delay elements are used with the resulting code as the modulus additions of different delays, see upper part of Figure 2.11. The rate of the code is defined as the number of different inputs divided by the number of different outputs. Convolution codes are commonly decoded with a so called trellis decoding scheme. Convolution codes use either tail-biting or zero-forcing. Tail-biting means that the end of the codeword is entered into the encoder in advance so the delay elements contain these values when the coding starts. This means that the trellis should start and end in the same state. The state is not known prior to the decoding. With zero-forcing the coder is instead cleared prior to the coding and a sequence of zeros is sometimes appended to the end of the codeword. Zero-forcing gives a known starting- (and ending)-state in the trellis but adds an additional overhead, significant for short codewords.

An expansion of the convolution code is the Turbo code. In a turbo coding system not one but two convolution coders are used. The receiver then starts out to try to decode the bits, with help from the parity-bits coming from the first decoder, with no priori knowledge of the expected result. Then, with the result from the first decoding as prior knowledge, a new decoding, now with the help the second encoder's parity-bits, is performed. Then the procedure is repeated on the first encoder with the knowledge now attained in the second decoding. The procedure is repeated until correct detection or no more information can be attained. The name turbo-codes come from this accumulating use of prior information. A requirement for a turbo code to work well is the use of long code words. The interleaver should work on long enough blocks to make the coding from the two convolution encoders independent. [5]

For fix length codewords a block code is usually best if a suiting one can be found. For intermediate length codewords a tail baiting convolution code is good and for long codewords, hundreds of bits, a turbo code is the preferred one.

To match a code to a certain code rate the codeword can be punctured; removal

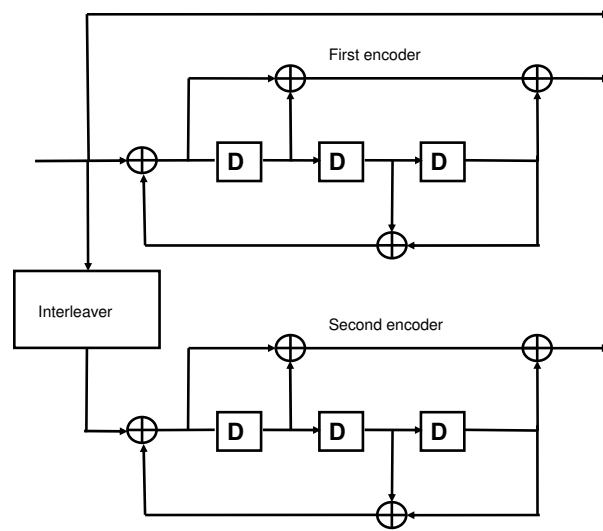

Figure 2.11. Rate 1/3 Turbo encoder. A conjunction of two convolution coders with a predefined interleaving.

of a predefined set of bits later interpolated in the receiver.

2.8 Error Detection, HARQ

As a complement to the error correction codes, an ARQ (automatic repeat request) can be implemented. Instead of correcting errors does an ARQ only detect errors and ask for a retransmission. The detection of errors is not as costly in information rate as correction. For the same number of parity-bits approximately twice as many errors can be detected as can be corrected. One of the most commonly used ARQ-scheme is the stop-and-wait ARQ [5]. The stop and wait scheme transmit one message, then waits for an acknowledgement (ACK) or a negative receipt (NACK). For a NACK it will retransmit the last message and for an ACK it transmits the next. To make an effective system with a stop-and-wait scheme one uses multiple ARQ processes. This means that when a package is transmitted and the system waits for an ACK/NACK the next process can start to transmit, and so on. If the number of processes times the transmission time is larger than the time it takes to receive the ACK/NACK is the system waiting time gone.

FEC and ARQ can be used simultaneously to create a HARQ (hybrid ARQ) system. There are two types of HARQ-systems, regular and soft-combining. In a regular system the received codeword is first decoded using the FEC, if this fails does the ARQ ask for a new transmission of that codeword and a new process is started, this is often referred to as Type-I HARQ. With soft-combining the error codeword is not discarded but saved. Retransmission is then combined with the previous transmission. This can be done by energy combining, called chase combining, or by sending a different message containing more parity bits, called incremental redundancy. Both of these methods are referred to as Type-II HARQ. [11] Type-II HARQ gives better performance in terms of throughput, but is more complex to implement since it requires memory.

2.9 Multi-Antenna Systems, MIMO

As we saw in section 2.2 does the channel quality and correlation change fast in space, two receivers half a wavelength apart can receive data with a greater change in quality. Half a wavelength is less than 10 cm with a carrier frequency of 2 GHz. Instead of seeing this as a problem it can be utilized by adding additional transmitting and receiving antennas. This is called MIMO (multiple input multiple output). The diversity gain from MIMO can be used differently depending on the channel characteristics and the desired effect. The simplest form of diversity gain is receiver diversity. If a receiver has multiple antennas the received signal can be combined from all the antennas, to reduce interference. More or less advanced methods for combining exist [5]. The most advanced is called Maximum Ratio combining. With Maximum Ratio combining the SIR from the different antennas can be summed. The transmitter counterpart of receiver space diversity is beam-forming. Beam-forming can be used to further direct the effect coming

from an antenna constellation, gaining better coverage and a more controlled spatial interference. Beamforming is done by transmitting the same signal from all antennas but with different time shifts. Beam-forming also gives a possibility for MU-MIMO (multi user MIMO), sending to multiple users on the same frequency giving that they are far enough apart. If the channels between the different antennas are highly uncorrelated multi-layer can be used. With the gain for uncorrelated antennas multiple codewords can be sent simultaneously. If the channels characteristics, H_f in Figure 2.12, is known and have favorable characteristics (rang higher than one) a precoding, W_f , can be done to send multiple layers detectable at the receiver. H_f is the channel matrix elements $H_f(i, j)$ being the channel from transmitting antenna i to receiving antenna j . The precoding W_f maps the different streams to the antennas in a way to make detection as easy as possible. The precoding W_f should preferably be chosen freely to fit H_f , but is commonly chosen from a predefined codebook with a number of fixed codes. This is to limit the uplink overhead. The UE reports a pointer to a preferred precoding instead of a full H_f matrix. The maximal number of layers is limited by the number of sending or receiving antennas, whichever is smallest. It is defined by the rang of the matrix H_f . A combination of beam-forming and multi-layers is also possible [8].

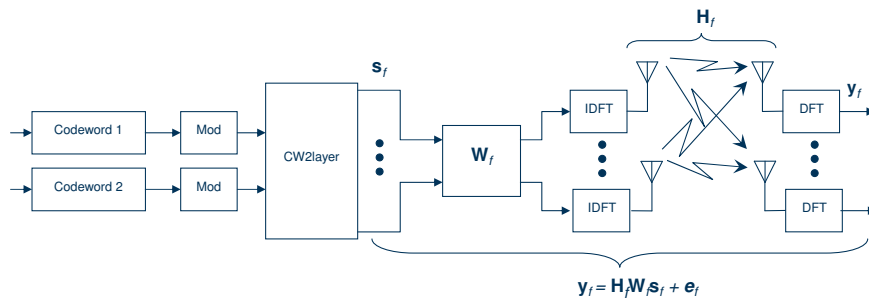

Figure 2.12. Description of a dual-word MIMO system. Two codewords mapped to the antennas according to W_f . H_f express the channel characteristics.

2.10 Channel dependent scheduling

With detailed knowledge about the quality of the channel it is possible to adapt the modulation and the coding rate to reach a pre-defined BLER-target. The BLER-target is set to maximize throughput and minimize delay. A common target is 10% HARQ-retransmissions. For example, if there is a relatively good channel a high order of modulation and a lower number of parity bits can be sent. When the channel is poor only a low complexity modulation, for example BPSK (binary phase shift keying) modulation with only two points in its constellation diagram, together with a low code-rate is selected. With multiple users spread out in space they will probably not experience their channel quality dips at the same frequency

at the same time. So if a user with a good channel at a certain frequency and time uses that portion of the channel the total throughput will be higher. This is called channel dependent scheduling. This scheduling can for the third generation cellular system, e.g. WCDMA (Wideband Code Division Multiple Access), only be done in time, since all users transmit on all frequencies. This is also done with the HSPA upgrade in 3G. With an OFDMA system channel dependent scheduling can be used in both time and frequency. The potential gain have been showed to be great, up to 60% compared to doing scheduling only in the time domain [21]. One problem with this type of allocation scheme is how to optimize it. If optimization is done on cell throughput, the user with the best channel gets assigned. But then users on the edge of the cell will never or only seldom be scheduled compared to users close to the base station. This scheduling is referred to as maximum C/I.

A proportional fair scheduler was suggested in [12], giving a good compromise between fairness and system throughput. The proportional fair scheduler calculates a users scheduling priority for a sub-band from the quality compared to the average channel quality. This results in lower total throughput but is in a sense fairer, giving each user an equal part of the channel while still taking advantage of channel knowledge. An alternative fair scheduler, called Best Effort, also consider historic throughput when assigning users, giving all users the same average throughput. This is of course even worse on total throughput and can take away the advantages of channel dependent scheduling, at least in the time domain. The alternative to use channel dependent scheduling is to use a Round Robin scheme, letting all users transmit in order.

To make a scheduler that can handle many users in real time is a complex operation. To be able to find the optimal scheduling solution an immense computation power is needed. Because of this simplified versions are often used in real systems.

2.11 Channel Quality Estimation

To be able to conduct channel dependent scheduling one needs to know the channel. This knowledge can in practice only come from measurements. The measurements can be conducted in two ways in the downlink. Either can the UE make measurements on a set of predefined reference symbols, or on the received data [14] [23]. Measurements on data do not cost anything in downlink overhead but are less accurate compared to the reference symbols. The reference symbols can be placed as tones or as a training sequence in time in an OFDM system. These will if chosen correctly give the same performance [13]. Usually a SINR (signal to interference and noise ratio) is calculated. The accuracy of a report depends highly on the measurement time and time granularity. The finer granularity is in time the more error will the measurement contain. Channel knowledge is also important in detection, by knowing the channel compensation can be made against things like phase-shifts and amplitude degradation. It is shown [14] that the RMSE (root mean square error) of the measurement can be in the range of 2-3 dB and no smaller than 1 dB in an OFDM system like the one intended for LTE.

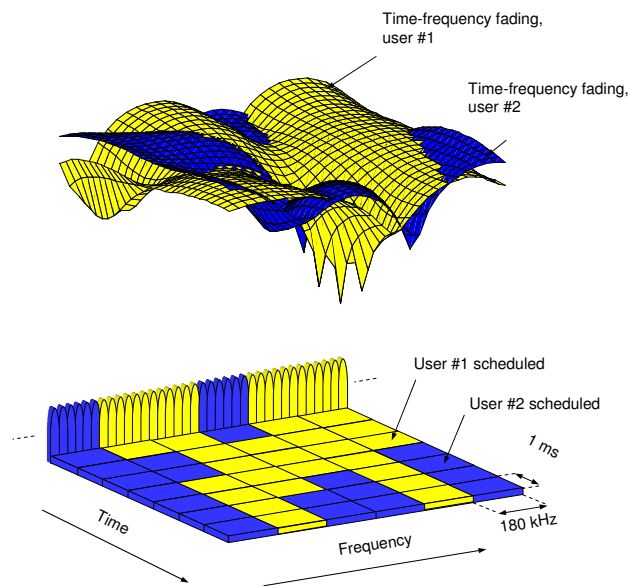

Figure 2.13. Example of channel dependent scheduling. Two users get assignments according to instant channel quality.

The number of reference symbols also effects the measurement; the more symbols the better, more accurate, measurements. But the number of reference symbols limits the channel, no information can be sent on those symbols.

When a MIMO system is in use, all channels must be estimated. This can be done by using separate reference symbols for the different transmit antennas, preferably are all other antennas quiet during the time another is transmitting its reference symbols. This leads to higher and higher cost in overhead so it is a balancing between the gains from better channel knowledge versus the loss to the needed overhead.

Chapter 3

Long Term Evolution

3GPP (Third Generation Partnership Project) is a collaboration between standardization bodies mainly from Europe, Japan, China, USA and Korea. It was founded in 1998 to work on the development of the third generation mobile telephony, WCDMA in FDD and Time Division - Code Division Multiple Access (TD-CDMA) in TDD. Also development of the Global System for Mobile communications (GSM) standard has been conducted inside 3GPP. To meet future demands of mobile communication systems a study case on further evolvement of 3G was conducted in 2004. The result came out as a set of demands on the next step in the radio network development. 3G LTE will have peak bitrates of 100 Mbit/s in downlink and 50 Mbit/s in uplink for a 20 MHz spectrum allocation. It will have an architecture adapted to flexible spectrum-size, working in allocations from 1.25 up to 20 MHz bandwidths for both TDD and FDD. The average throughput should be at least 3-4 times better than 3G defined in 3GPP Release 6, and also the latency and state-transition, idle to active, should be better by a factor 3-4 compared to Release 6 [3]. LTE will also contain support for multi-cast, transmission of the same data to multiple users in a more efficient way than transmitting individual packages to all receivers.

To meet these demands a system is now designed by multiple vendors contributing to the standardization. The first release of the LTE standard shall be complete by 2008.

For more information about 3GPP and higher layer functions in LTE, see [1]. 3GPP also works in parallel with a new core network architecture under the acronym SAE (system architecture evolution).

3.1 System design

The physical structure selected for the downlink is an OFDMA system, for the good spectral efficiency and its natural adaptation to MIMO. A sub-carrier spacing of 15 kHz is selected. This gives a symbol time of approximately $66.7\mu\text{s}$, an additional cyclic prefix of $4.7\mu\text{s}$ is added to this in the normal case. A longer prefix is available if needed, for example for large cells in hilly terrain. The time/frequency

plain is divided into slots. One slot is 0.5 ms, 7 symbols, in time and 12 sub-carriers in frequency. 12 consecutive sub-carriers are referred to as one sub-band. Two consecutive slots in time make a sub-frame and a sub-frame is the smallest assignable resource unit, see Figure 3.1. The length in time of a sub-frame, 1 ms, is referred to as a TTI (transmission time interval).

The downlink has one control channel, PDCCH (physical downlink control channel), and one data channel, PDSCH (physical downlink shared channel). The control channel consists of the first resource elements every sub-frame. Dependent on need one, two or three resource elements are taken per tone. In Figure 3.1 two elements are taken. The PDCCH is for grant signaling; both uplink and downlink, and HARQ related information. For channel estimation a number of reference symbols is inserted, marked dark in Figure 3.1. The rest of the OFDM-symbols are for data, PDSCH. The PDSCH can be assigned to users in terms of sub-frames. To limit the grant messages on the control channels assignments will not be done totally free, but the available assignment schemes are not decided.

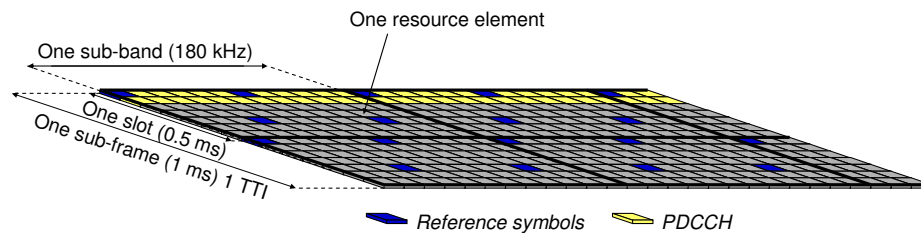

Figure 3.1. Layout of the LTE downlink channels.

In the uplink SC-FDMA is intended, to spare handheld device's battery-time. The uplink channel has the same layout as the downlink except for the reference symbols and control channels. The uplink also consists of a data channel and a control channel, the physical uplink shared channel (PUSCH) and the physical uplink control channel (PUCCH). All traffic on PUSCH is grant-based. For a UE to be allowed to transmit on PUSCH it must first receive a grant from the base station on the PDCCH. The grant states which part of the channel and which transport format (coding and modulation) to use. All uplink payload traffic is sent on the PUSCH. PUCCH is a dedicated control channel and only control data is transmitted on it, like HARQ acknowledgements, scheduling requests and CQI-information. Physically the PUCCH is one or more sub-bands on the edges of the spectrum. The channel jumps from the bottom to the top, or vice versa, of the total spectrum every TTI to gain some frequency diversity. See Figure 3.2. Allocation on the PUCCH is done implicitly for HARQ Ack/Nack and by RRC (radio resource control) for CQI and scheduling request. Reference signaling in

the uplink can not, like in the downlink, take one individual resource element because of the single carrier nature. Instead reference symbols are transmitted over the entire assigned bandwidth twice per sub-frame. A sounding scheme to get an estimate of the entire uplink channel also exists. A RACH (random access channel) is also intended in the uplink to let new users into the system.

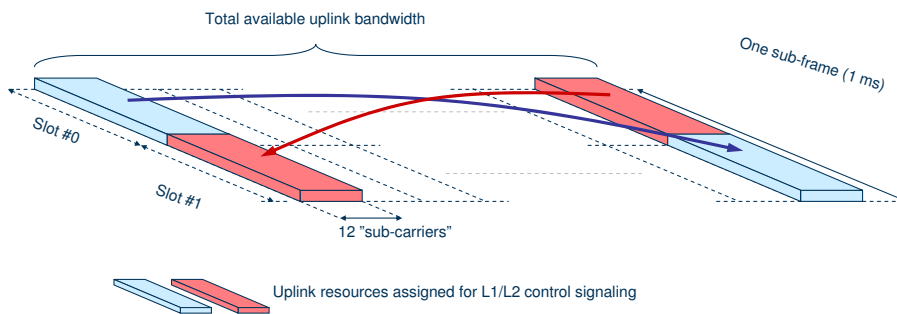

Figure 3.2. The LTE uplink control channel PUCCH. Placed at the ends of the spectrum.

3.2 Link adaptation

In the downlink, and the uplink, the freedom for link adaptation is reduced to only being able to select one transport format, modulation and code rate, for the entire assigned band. Optimal would have been to be able to select a transport format optimized for each sub-band, but it has been shown that only a very small gain come with this. This limitation is introduced to reduce the needed overhead to signal to the UE what transport format to expect and to send with. The modulations available in LTE are QPSK (2 bits), 16-QAM (4 bits) and 64-QAM (6 bits). For data is a rate 1/3 Turbo code used (described in Figure 2.11), with rate matching. For error control parallel stop-and-wait HARQ processes are used.

3.3 CQI-Compression

The amount of feedback data required to transmit all knowledge of the channel known by the UE is often too large. For example, if all sub-carrier's quality in a 20 MHz deployment should be reported with 5 bits granularity every TTI it would require 6 Mbit/s of uplink overhead per user. Two methods to avoid sending all data are Best-M and Scanning. They exploit two different communication system phenomena.

3.3.1 Scanning

The Scanning compression scheme exploits the channel correlation. By clumping sub-bands together and only report one value for each clump the total overhead can be reduced. A problem with this method is to decide the number of sub-bands to include in a clump. The aim is for the sub-band qualities to vary little within the same clump but to have as few clumps as possible. The number of clumps must then depend on the coherence bandwidth, which varies dependent on the landscape. This method works differently well dependent on how the scheduler works and the data load. There is never a reason to report smaller clumps then the scheduler assigns. This is because only one modulation and coding is selected for the assigned clump. The UE transmits one 5 bit overall average and 3 differential bits for each clump. This method is investigated in [24] and it is showed that for a Rician channel is no more gain found for sub-channels smaller then 1/4 of the coherence bandwidth. It is also, and maybe more relevantly, showed that a distinct gain can be detected for reporting bands up to as large as 16 times the coherence bandwidth.

3.3.2 Best-M

In the Best-M scheme does the UE select the M best sub-band clumps, were M is an integer value. The average channel quality of these bands is calculated and transmitted together with a pointer to which bands that are used. The UE also transmits an average channel quality over all the bands. The thought behind the Best-M scheme is that each user gets assigned its best bands if the scheduler has many users to choose from. Since only the best bands are used there is no reason to waste overhead-bits on reporting less good bands. Two problems with this method are to decide how many sub-band clumps that should be reported and also the width of the clumps. The UE transmits a 3 bit differential average over the best M sub-bands-clumps and a 5 bit average over the rest of the sub-bands. Also a pointer to the M best sub-bands-clumps is transmitted with $\left\lceil \log_2 \frac{N!}{(N-M)!M!} \right\rceil$ bits. N is here the total number of sub-band-clumps, for 20 MHz and two sub-bands per clump, N will be 50.

Many more complex ideas for compression of CQI have been suggested within 3GPP, like Haar compression, DCT-transform compression [18] and threshold based reporting. Some of these methods can work very well, but due to their complexity and patents they will not enter the standard, since it would lead to more expensive products.

3.4 CQI-Transmission

Because of the single carrier technique used in the uplink a user scheduled to transmit on the PUSCH can not transmit on the PUCCH as well. This is because the allocations do not form a consecutive spectrum. When a scheduled transmission coincides with a transmission on PUCCH, for example a HARQ acknowledgement, the control signaling will be transmitted with the data on the PUSCH.

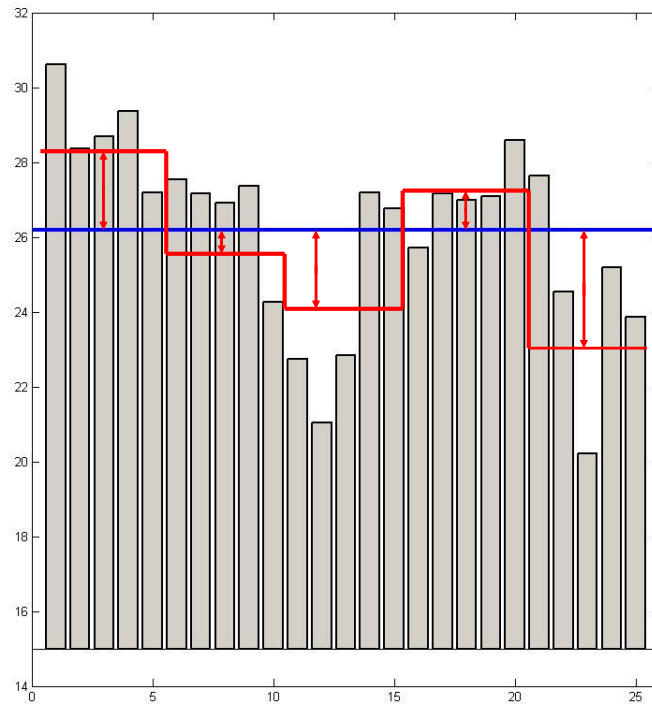

Figure 3.3. Scanning compression algorithm. Chunk size of 5 sub-bands over a 5 MHz spectra.

Since the capacity on the PUCCH is lost when coinciding with a scheduled transmission, and because of the low flexibility of the channel, it is a goal to keep it as small as possible. This means that when reporting CQI on the control-channel it will only be approximately 10 bits available. This is enough for reporting only a single value, probably a mean over all sub-channels, and a pointer to the MIMO-precoding codebook. To enable frequency domain adaptive scheduling more fine-granular reports are needed. How to transmit these reports is still under consideration.

An idea is to let the UE transmit a larger report on those occasions when it has an uplink grant at the same time as it where supposed to send a PUCCH-CQI-report. Or otherwise to always transmit CQI with data. This means unfortunately that if there is no uplink-data present, no large report will be sent. Since much of the larger data traffic is sent with TCP (Transmission control protocol) which generates accept packages, there will be uplink traffic, but the question is if it will

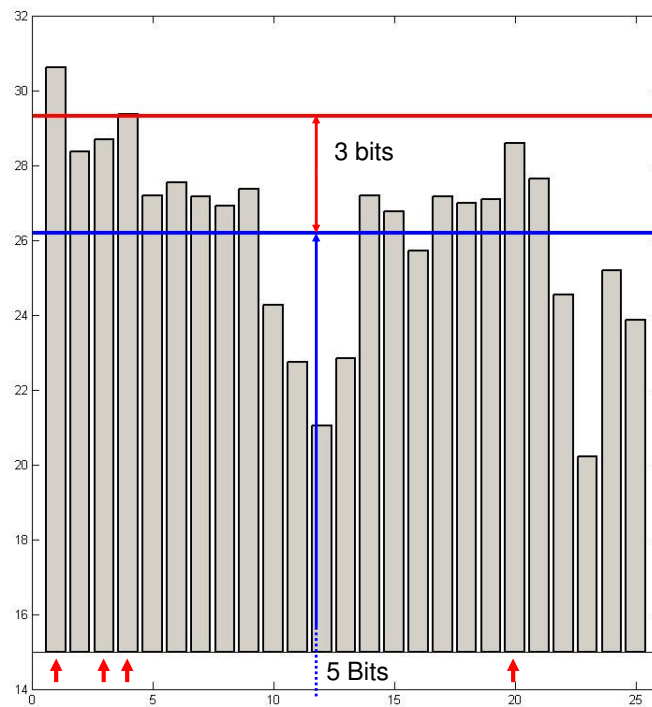

Figure 3.4. Best M compression algorithm, $M=4$. Chunk size of 1 sub-band over a 5 MHz spectra.

be enough.

One idea is to use multiple consecutive allocations on PUCCH and, instead of transmitting an average, transmit the quality for a portion of the channel every TTI. The downside with this method is that it can take a long time to get full channel knowledge, and the information can then be outdated. This method also puts higher requirements on the PUCCH capacity. How the allocations should be made for this kind of traffic on PUCCH is also an issue.

A different, or complementary idea is to be able to schedule a user to transmit CQI, without it necessary having any payload data to transmit. This gives a lot of freedom for the scheduler but increase the downlink overhead.

Chapter 4

System Evaluation Methods

4.1 System Simulator

To evaluate the performance of an LTE system with and without channel dependent scheduling a system simulator developed at Ericsson Research is used. Different scenarios and models can be loaded into the simulator and logging can be done on most performance parameters. Some simplifications are made to keep the computational requirement down, while still trying to keep the performance as close to a real system as possible. Users can be created and terminated according to different distributions and generate traffic according to different traffic models, like VoIP (voice over IP) or web traffic. The modeling this report focuses on is scheduling, deployment, propagation, control channel limitations and traffic models.

The logging is mainly focused on user and system performance in means of user bitrate and cell throughput. The throughput is measured over transported bits per cell and second, averaged out over all cells and the entire simulation time. The simulation time is selected to 30 seconds to give some statistical stability to the simulation results, while still keeping the simulation-time short. The logging starts after 3 s to avoid transient behavior and simulation time dependent results. The user bitrate is measured as the payload in a TCP package over the time it takes to transmit it, averaged out over all transmitted packages for each individual user. This measurement is not so good when looked at individually since the number of transmitted packages in 30 seconds is rather small, between 0 and 10. Therefore a CDF (cumulative distribution function) over all users is constructed. A CDF is a graph over the portion of all users who have a value, for example bitrate, lower than a value x . This shows how fair the resources are distributed and the good and bad user's performance is easily identified. To get a picture of how well the system performs it is common to look at different percentiles in the CDF. For example can the poor users often be defined as the 5th percentile, that is the performance of the user with only 5% of all users having worse performance, lower line in Figure 4.1. The same can be set for high performance user at the 95th percentile, top line, and the average user, middle line. To further see how different parameters affect

performance a certain user bitrate percentile can be mapped to a cell throughput. This shows for example what happens to the best users when the number of users increases, Figure 5.2(c). All plots are generated in MatLab from simulation data.

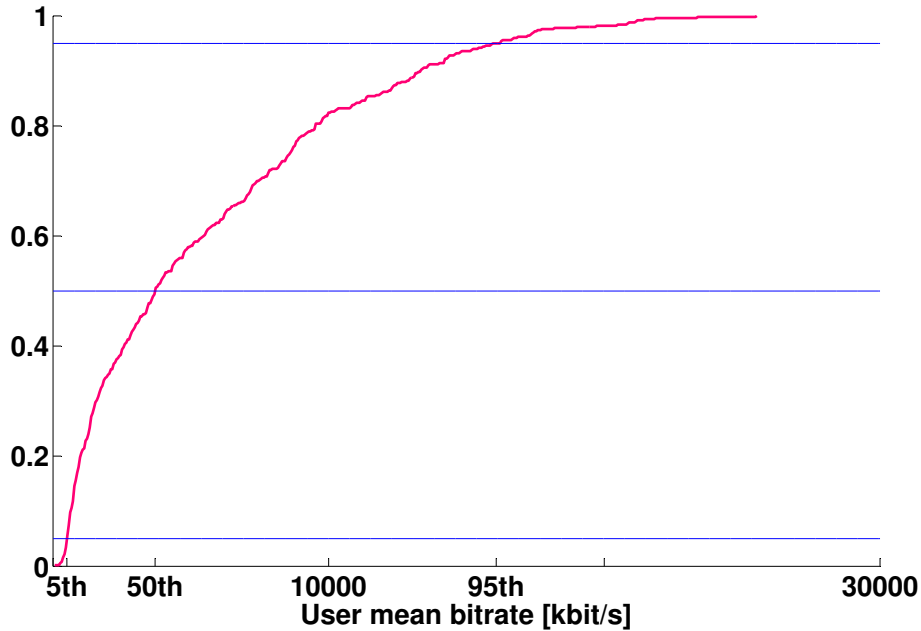

Figure 4.1. Example of a CDF; User mean bitrate for 500 users in 9 cells. 5th, 50th and 95th percentiles marked.

4.2 Deployment

The simulations are run on a hexagonal grid, Figure 4.2, with a number of sites. Every site has 3 cells. The site to site distance is set to 500 meters. The users are created on a random location evenly distributed over the entire simulation area. This leads to some cells containing more users and others less. To accurately simulate interference the number of simulated cells shall be large, but this leads to longer simulation time. Simulations will be conducted for both a 7 site and a 3 site simulation area. To simulate a large system a wrap-around technique is used. Wrap-around means that if a user, or interfering transmission, goes "over the edge" it will come back into the simulation area from the other side. Users move in a straight line according to a random direction decided at creation. Movement speed is, if nothing else is stated, 3 km/h. This should emulate slow walking.

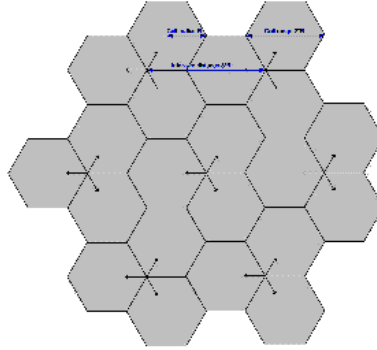

Figure 4.2. Deployment according to a hexagonal pattern. 3 cell per site. 500 m inter-site distance.

4.3 Propagation

The Okumura-Hata model is used for slow fading in all the simulations conducted in this thesis work. The path-gain can be divided in to three parts; distance gain, antenna gain and shadowing gain.

The distance gain depends only on the distance between the transmitter and the receiver. An attenuation factor of 3.76 is used. Because the propagation model does not work well with small distances, for users close to the base station, a minimum distance is set to 35 meters. A user closer than this will still have an attenuation as if it was 35 meters away.

An antenna gain of 14 dB is assumed in the frontal direction for the base station. The antenna has a quadratic declination dependent on the horizontal angle diverted form the maximum, down to a minimum gain of -6 db. The declination reaches 3 dB at 70°. This is showed in Figure 4.3. A simple two-dimensional model is used so the gain is not dependent on the vertical angle. The UE have two isotropic receiving antennas with Maximal Ratio [5] combining and one isotropic transmit antenna. No space-diversity is used in the uplink.

The shadowing, random degradation from being behind buildings or mountains is assumed random with a lognormal distribution with mean 0 and an 8 dB standard deviation. The e^{-1} correlation distance for the shadowing is 50 meters. The propagation parameters are from the test case defined in [2], appendix A.2. For more information about the propagation model see [2].

The multi-path fast fading model used is based on 3GPP's typical urban model described in [4]. The model is generated with 8 Rayleigh-faded taps. A coherence bandwidth of 1 MHz is assumed. See [2] case 1 for more details on propagation parameters. A 20 MHz band is used for the simulations.

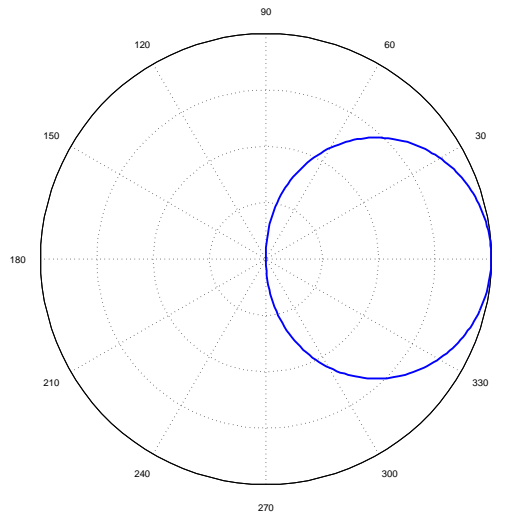

Figure 4.3. Gain of directional antenna in azimuth angle. R-axis ranging from -6 to 14 dB.

4.4 Scheduling and Limitations

To emulate the downlink control channel and reference symbols, the number of symbols in a downlink sub-frame is reduced from 168 (12 sub-carriers * 14 symbols) to 138. The error probability on the control channel is idealized set to 0. A grant limitation is set to 16 users in both uplink and downlink, but no limit is set on possible assignment constellations. Noted in the simulation was that the grant limitation was never reached. The uplink control channel is simulated by the removal of five sub-bands, so the uplink works over 95 sub-bands instead of 100. To emulate reference symbols, RACH and other things limiting the uplink, the number of symbols in the uplink is reduced to 140. When the uplink control channel is used for CQI-reports a 5 bit average is transmitted every 5th TTI. Also in the uplink control channel the error probability is set to 0.

8 consecutive stop-and-wait Type-II HARQ processes with incremental redundancy are used, so the round trip-time is 8 ms. The BLER target is fixed at 10%. The downlink HARQ uses an asynchronous adaptive scheduling algorithm. This means that the retransmissions are scheduled like all other, but with a weight-bonus, with a new transport format to fit the new channel quality. In the uplink synchronic non-adaptive scheduling is used to save grants. Synchronic means that the retransmission occurs exactly 8 ms after the first transmission and non-adaptive means that the same sub-bands and same modulation and coding are used. Zero error probability is assumed for HARQ ACK/NACKs. Mapping to transport formats is conducted by mapping each sub-band SIR to soft symbol information, for every possible modulation, section 3.2. This mapping indicates how much information, needed code rate, that can be sent for a given modulation and SIR, Figure 4.4. The modulation with the highest total soft symbol information summed over all the sub-bands is the one selected. A modeled rate 1/3 Turbo code with rate-matching is used.

Two different schedulers are used in the downlink; Best Effort (BE) and Round Robin (RR). Mostly the BE type of scheduler is used. All priorities are given in a point-like fashion where different priority gives different amount of points. The best effort scheduler gives a user with low average rate, compared to the total average rate, higher priority. It also gives priority based on CQI and whether a user has been scheduled already, to save grants. The Round Robin discards CQI information in scheduling and gives priority to users based on how long since its last scheduling. A user can be assigned a portion of the channel able to carry more bits than the user has. In this case the output effect can be lowered to get a transport format that better fits the data.

A resource Proportional Fair scheduler is also tested for reference. This scheduler gives bonus if a user has been assigned less than the average amount of the channel. It also prioritizes on CQI.

The schedulers are modeled to work in both the frequency and time domain. Sometimes only time domain dependent scheduling is of interest. It is then modeled by setting the same average value for all sub-bands. Note that neither the proportional fair nor the best effort works exactly like described in section 2.10. Because of the point based system the schedulers will rather be a combination of

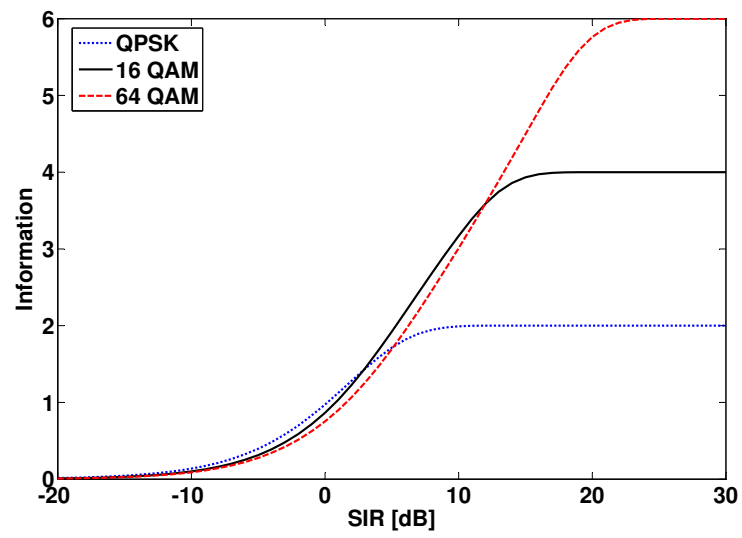

Figure 4.4. Mapping from sir to soft information for the three modulation-schemes intended for LTE.

the schedulers described in section 2.10 and a maximum C/I type scheduler.

All channel quality averaging, like for the scanning report, is done in the bit domain. This means that instead of calculating an average SIR does the UE calculate an average of how many bits it can transmit per sub-band and then converts it back to SIR. This is because of the nonlinear mapping between transmitted bits and SIR, see Figure 4.4.

4.5 Web traffic model

To produce traffic a web traffic model is used. It produces packages according to a random model. Fix packet size of 200 kbytes in the downlink and 50 kbytes in the uplink is used. The first package is requested after an initial waiting period according to an exponential distribution with mean 2 s and truncated at 5 s. The request package is 400 bytes. After the correct reception of a package another packet is requested after a random reading time, also exponentially distributed with mean 1.5, with lower cut-of at 1 and higher at 5 seconds.

All web traffic uses the TCP (Transmission Control Protocol) and IP (Internet Protocol) protocols. The TCP divides the package into smaller segments, if needed, and adds an additional ARQ control to each segment. It also implements the TCP slow start to avoid congestion in lower layers. The TCP header size is 160 bits per segment. The IP controls addressing of packages and adds another 160 bits of header to each package, actually a TCP-segment. Techniques for compressing headers exist but are not used in the simulations.

Special for radio interface data transmission is the RLC-protocol (radio link control). This protocol controls the radio access dividing the packages into the size the channel allows. It can also add an additional ARQ, but this is not used. To control the segmentation another 28 bits per package and 15 bits per RLC-segment is added.

4.6 Expected Results

Some speculations can be made regarding the expected results from different simulations. Firstly, degradation in downlink throughput if the load in the uplink grows large compared to bandwidth should be seen. This is because of the delays in TCP acknowledgement packages and new packet requests. This limits the amount of CQI data that can be sent for a downlink gain, when the CQI report size increases there will probably be gains from frequency selective scheduling but loss in uplink bandwidth. According to the studies made on radio channels the reporting delay and infrequencies will affect the performance negatively, especially for delays larger than, or the same size as, the channel coherence time. The gains from frequency selective reports should be more affected by the delays than the average reports, since the change is faster per carrier than in average. The frequency selective reports should also be more affected by measurement errors. This since the average report averages out the errors as well. This way it gains much lower variance.

Chapter 5

Simulations

In this section the results from the simulations will be presented. A number of tests have been conducted to test different aspects effecting CDS.

5.1 Load Test

The gain with channel dependent scheduling is most prominent with a high load, when the scheduler has many users to choose from. With many users to choose from it is more likely to find a user with a good channel. A set of simulations are conducted to find a suitable workload. Simulations with an increasing number of users should show an increasing total throughput of the system up to a point, where the system saturates. The throughput saturates at different loads for different schedulers. Because of this the load test is run for a frequency- and time-domain BE scheduler, a time-domain BE scheduler and a Round Robin scheduler.

From the throughput chart, Figure 5.1, it can be seen that the throughput saturates for more than 500 users for time-dependent BE scheduling. 500 users in 9 cells give a mean of 56 users per cell. A saturated system is sensitive to simulation time and of course not a good working point for a real system, since all users don't get all their requested data through. The system with frequency domain BE scheduling saturates later, for a load of approximately 800 users. The capacity of a full granular frequency domain scheduling is approximately 30 % better then a system with only time domain adaptive scheduling in this simulation scenario. The throughput gain for the frequency and time domain scheduler is approximately 15-20% better compared to CDS in time domain only for 500 users in 9 cells. With a higher load the gain will increase but the comparison is then not really fair.

In Figure 5.2(a), 5.2(b) and 5.2(c), it is shown that the 5th and 50th percentile user throughput goes down almost linearly for higher load, but that the 95th percentile users performance is almost unchanged until it plunges, for 500 and 650 user respectively, for both BE schedulers. Interestingly are the user bitrate for the poor and average users (5th and 50th percentile) is almost the same for the two BE schedulers. The good users (95th percentile) have almost 12% higher bitrate with

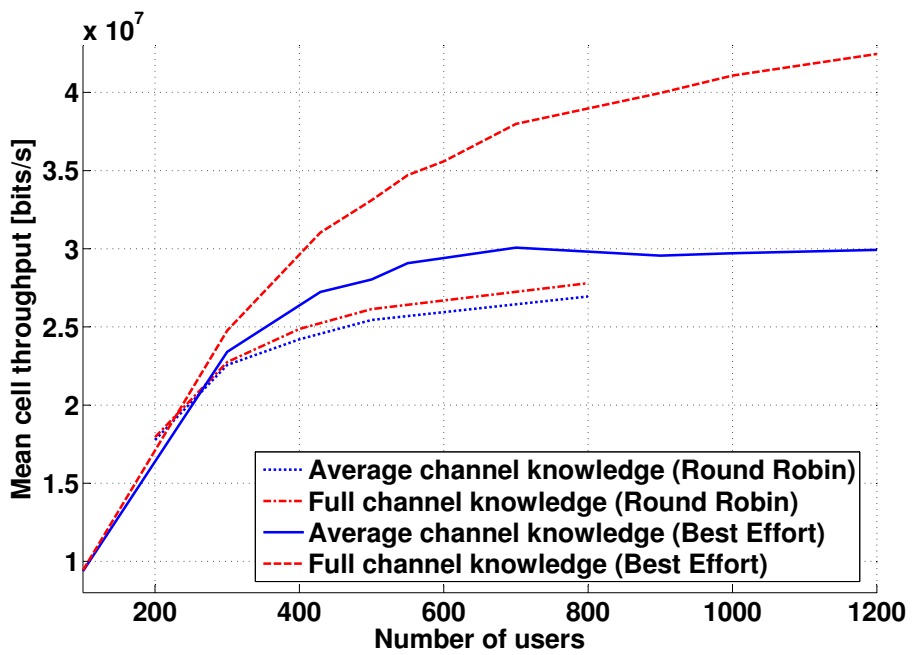
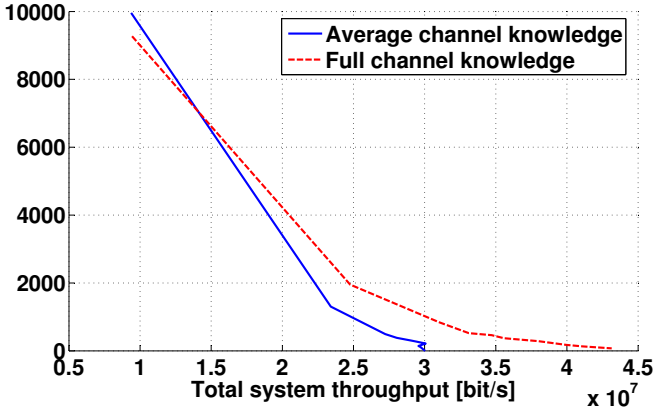
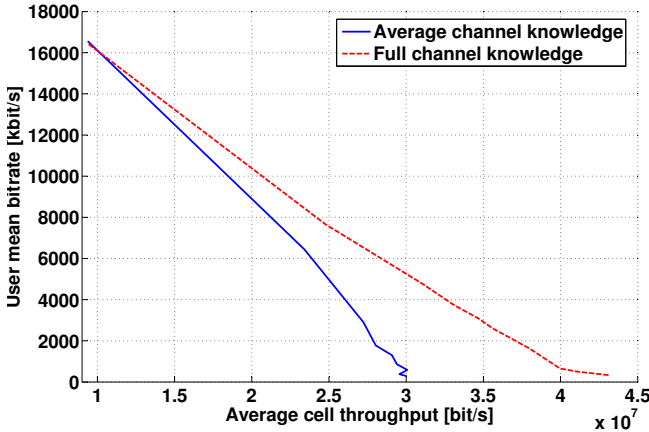

Figure 5.1. Throughput for Best Effort in; time and frequency and time only, Round Robin with full granular link adaptation and with average only link adaptation. Increasing number of users, 9 cells.



(a) The 5th percentile



(b) The 50th percentile

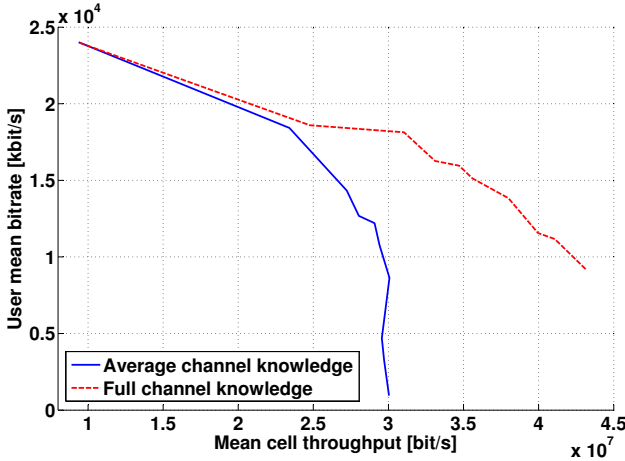

(c) The 95th percentile

Figure 5.2. User bitrate dependent on average cell throughput for 9 cells, increasing number of users.

frequency domain CDS. The number of users with very low throughput, unable to get one package through in 30 second, increases but are relatively small, less than 2% even for high loads. This means that the BE scheduler is quite performance fair, like it should be.

Noted in these simulations is that the uplink traffic is limited so the traffic in the uplink does not limit the downlink throughput. When the load in the downlink increases, so does the uplink traffic, with packet requests and TCP-acknowledgement packages but not enough to limit the downlink data in this case, like we can see in Figure 5.3. We see that more and more of the uplink channel is allocated, but even for 1000 users there is space left more than 20% of the time.

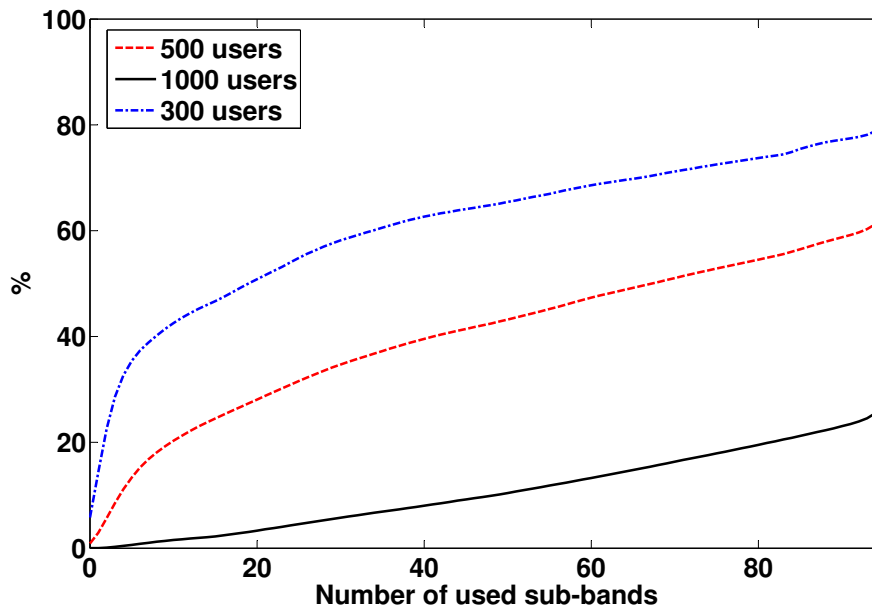

Figure 5.3. Allocations of the uplink channel for full granular reports with increasing number of users. 9 cells.

The potential gain from conducting frequency domain adaptive scheduling is shown in Figure 5.1. The gain with full channel knowledge is 30% and with only average channel knowledge it is still 10%, compared to a RR type of scheduling. The difference between the two RR type schedulers comes from better link adaptation. The improvement is small since RR often assigns the whole band to one user, because of the large packages.

Unfortunately we can also see in Figure 5.4 that the gain depends highly on the interference. With the assumption on inter cell interference for the 21 cell scenario the potential gain is gone. To try to explain this, a histogram over the soft

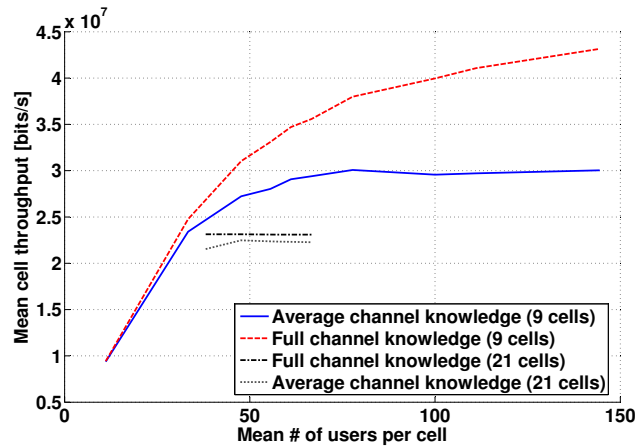

Figure 5.4. Cell throughput dependent on average number of users per cell. Both 9 and 21 cells with frequency and time and time only BE-scheduling.

information bit distribution is added. As seen in Figure 5.5 the bit distribution in the more interference loaded 21 cell system is not only lower but also more condensed. This means that the differences between good and bad bands lessen and the gain from choosing good bands is diminished.

The chosen set-up is extremely interference limited and can be viewed as somewhat of a worst case scenario. The rest of the simulations will run on the assumption that a less interference limited scenario exists and will be the one used. For the following simulation only 9 cells are used.

5.2 Scheduler Test

All three schedulers; Round Robin, Best Effort and Proportional Fair, were simulated for a system load of 500 users. As expected we can see that the total system throughput is highest for the Proportional Fair, Figure 5.6(b), but it is also most unfair, Figure 5.6(a). The Best Effort scheduler is the one used in all the rest of the simulations, because of the balancing between system fairness and CDS gain. We note that even higher gains with CDS can be found with different scheduling methods.

5.3 Delay Test

In the theory section it was shown that the coherence time for a user moving at 3 km/h is approximately 45 ms. This gives a quite poor estimation on how often a report has to be sent, it only says that if a report is older than this it is fairly useless. To test the effect of report age a set of simulations were run with different reporting delays. The reports are sent every TTI, but the time before their use

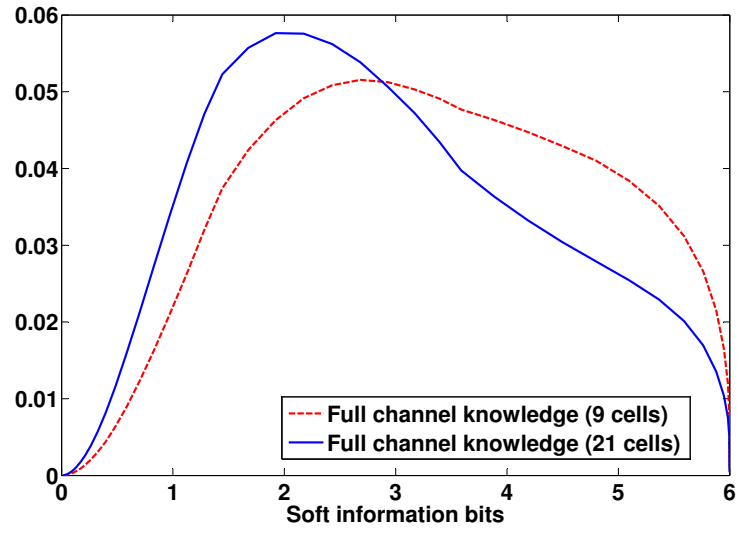

(a) Per sub-band

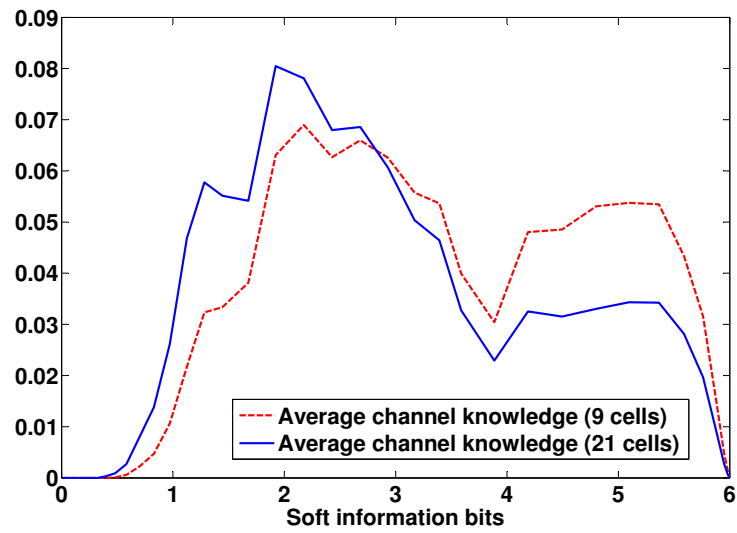

(b) Average over all sub-bands

Figure 5.5. Histogram over soft information distribution for a 9 and a 21 cell system with an average of 56 users per cell.

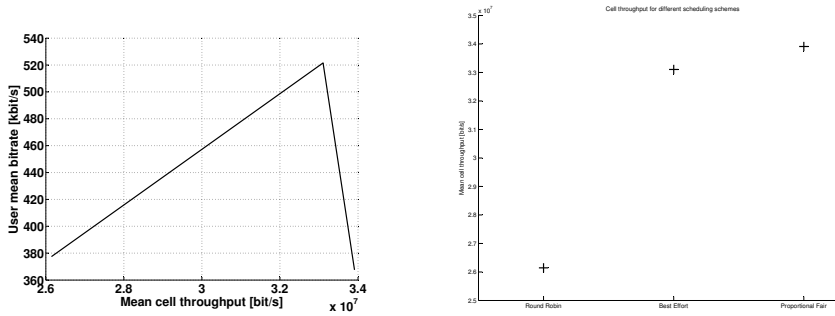

(a) Fifth percentile user bitrate with different schedulers (b) Cell throughput for different schedulers

Figure 5.6. System performance with different schedulers; Round Robin, Best Effort and Proportional Fair.

varies.

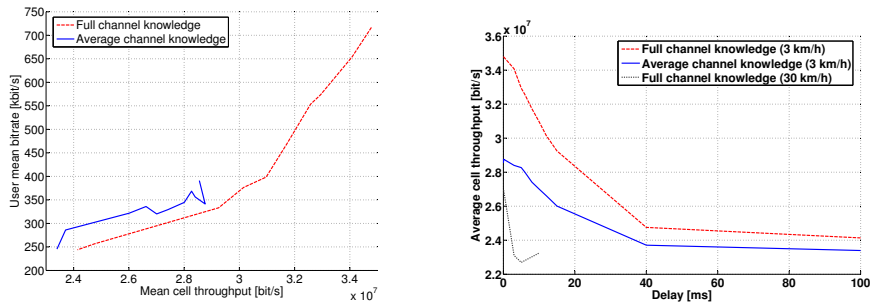

(a) Fifth bitrate percentile related to system throughput. (b) Cell throughput vs. reporting delay.

Figure 5.7. System performance with increasing reporting delay

As expected does the throughput decrease when the age of the reports increases, but stabilizes around 40 ms, Figure 5.7(b). The older the reports get the more does the gain from frequency domain scheduling decrease. We can also see the expected result from section 2.2. The frequency domain scheduling is much more sensitive to delays, and decreases quickly for small delays compared to only time domain CDS. The throughput is approximately equal for a 20 ms old fine-granular report as for a 3 ms average report. But the number of reported bits is then approximately 15 bits per TTI opposed to less then 2 bits in the average report case, so the gain depends on the cost of extra uplink data.

The use of a report compared to its age should scale linearly with movement speed, according to section 2.2.2. For a user traveling 10 times as fast, 30 km/h, the time a report is valid should decrease with as much. This can be seen in Figure

5.7. This can be interpreted as there being an upper limit on movement speed for the CQI-reports to have any effect. Users moving at a speed over this limit should not send any detailed reports. If 3 ms is considered a reasonable reporting delay we can see that the speed limit for any gain from frequency granular reports is at approximately 15 km/h. This from that we in Figure 5.7 does not see any gain with a granular report 15 ms older than an average report for a movement speed of 3 km/h. The results shown in Figure 5.7 are even worse for the fast moving users. This can depend on the poor link adaptation leading to high BLER. When the delay increases user-performance will go down for all users. What we see in Figure 5.7(a) is that the poor users still keep some throughput even for the long delays. This shows that timely reports are required for performance boost but not critical for system functionality.

5.4 Error Sensibility

To test how the measurement errors mentioned in section 2.11 affects the performance of the system the following simulation was run. To emulate the error from measurement a random, zero mean, log-normal error with an increasing standard deviation was added to the measured values. The values were reported every fifth TTI with a reporting delay of 3 ms. As mentioned in the theory section an error of approximately 1 dB can be expected from measurement errors and 0.5 dB from quantization, if 5 bit reporting granularity is assumed. All tests prior to this are run without any errors.

The measurement error affects smaller bands more significantly. The average report is hardly affected, as shown in Figure 5.8, since it averages out the errors over all the sub-bands. The full granularity report for frequency domain channel dependent scheduling is highly affected by the error. With a standard deviation in the measurement higher than 3 dB it is better to report only a wide-band average, where the errors are averaged out.

An error of about 1 dB does not affect the system performance substantially, this is also the error we can expect according to section 2.11. The HARQ processes are supposed to handle some deviation in the measurement values the link adaptation is conducted with. This is one reason why the BLER-target is not set to 0. In the simulations a back-off in link adaptation of 0.5 dB is also added to compensate for the fact that the channel change over time.

Note that Figure 5.8 only shows measurement error, an additional error from quantization will also be added to this and that error should affect the average measurement as well. The quantization error depends on the number of reported bits, and for an approximate 1 dB resolution 5 bits are needed. A resolution range from -5 to 20 dB approximately, see Figure 4.4, can be assumed. The standard deviation of the measurements will be kept at zero for the rest of the simulations.

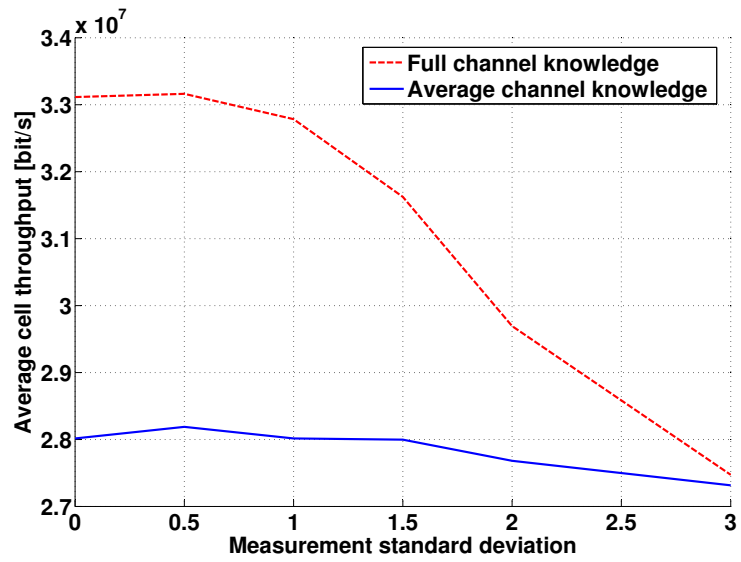

Figure 5.8. The effect of errors in channel quality measurement

5.5 Frequency granularity test

As discussed in section 2.2 there is not much to gain from having more detailed reporting than the coherence bandwidth. The scanning method tries to take advantage of this. The simulations shown in Figure 5.9 show how system performance depends on the granularity of the reports. The number of sent bits maps to number of reported sub-bands like described in section 3.3.

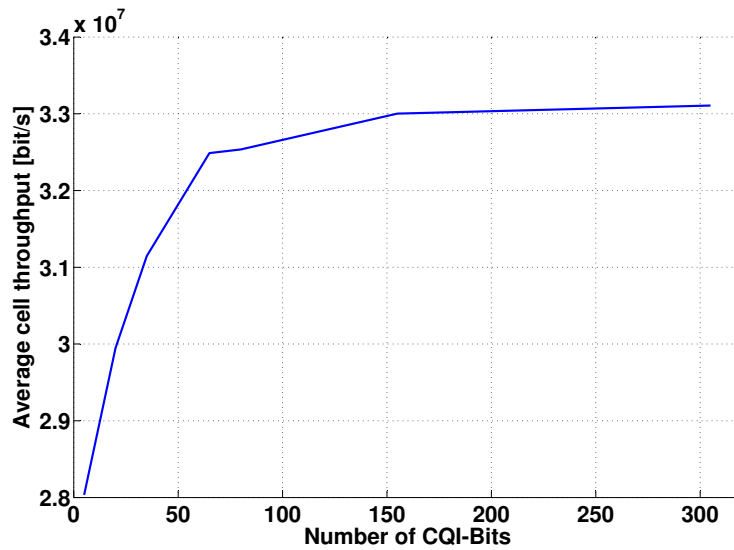

Figure 5.9. Throughput dependent on number of reported scanning bits, shows frequency granularity required

Firstly it can be noted from Figure 5.9 that full granularity reports are not necessary. Not until the reported bandwidths exceeds 900 kHz, 5 sub-bands, does the performance start to degrade. This correlates well to our assumptions on coherence bandwidth from section 2.2.1. Secondly we can also see gain with small reports, only a few different chunks. It is interesting to see a significant gain from reporting only a few different bands. This gain is much smaller than for full granularity reports but still noticeable. This corroborates the results presented in [24].

Noted in this test is that the result is highly coherence bandwidth dependent. The coherence bandwidth will vary between different cells, dependent on the landscape. This will give different curves for different cells. This can possibly lead to different ideal number of reported chunks but the general structure of the curves will likely be the same.

5.6 Best M test

To test the Best M reporting technique described in section 3.3.2 a plot is added to show the performance of the system with different settings. Simulations with different numbers of reported bits and different numbers of clumped bands were run. The number of bits to send for the Best M scheme is much smaller than for the scanning scheme, if small clumps are sent. But the granularity of a Best M report is smaller since only two values are sent. This can lead to situations where a larger M leads to poorer performance. This should happen when a significant portion of the allocations are smaller than the number of pointed out sub-bands.

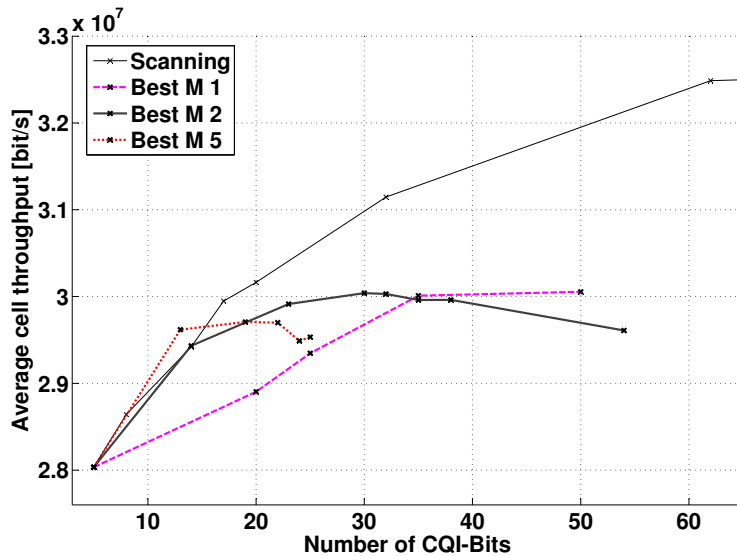

Figure 5.10. Mean Cell throughput for different variants of Best M, scanning is inserted for reference.

The simulations in Figure 5.10 show the expected saturation for large M. With the scanning as reference we can also see that the Best-M scheme works poorly for this scenario. The scanning scheme works better for all but one fix number of bits, 13, where a 5 sub-bands chunk Best 1 scheme works best. This can depend on the traffic model. Since very large packages are transmitted usually large chunks are assigned to each user. This can mean that the sub-bands covered by the Best M scheme are too few. Figure 5.11 gives a hint to why the scanning method works better in this scenario. The comparison is between scanning with 10 sub-band wide chunks and Best M, with 2 sub-band chunks, both reporting 32 bits. This gives an M of 6. We see that when using the Best M scheme are many users assigned all their 12 reported sub-bands. This is as it should be, but unfortunately does

it appear that only one or max two users gets multiplexed with their reported best bands. Often will users get assigned the whole bandwidth, or the rest after one user have been assigned its 12 best bands. We can see that fewer users are assigned the whole spectrum in the scanning case. This means that we probably utilize the user's best part of the channel better with the Scanning method.

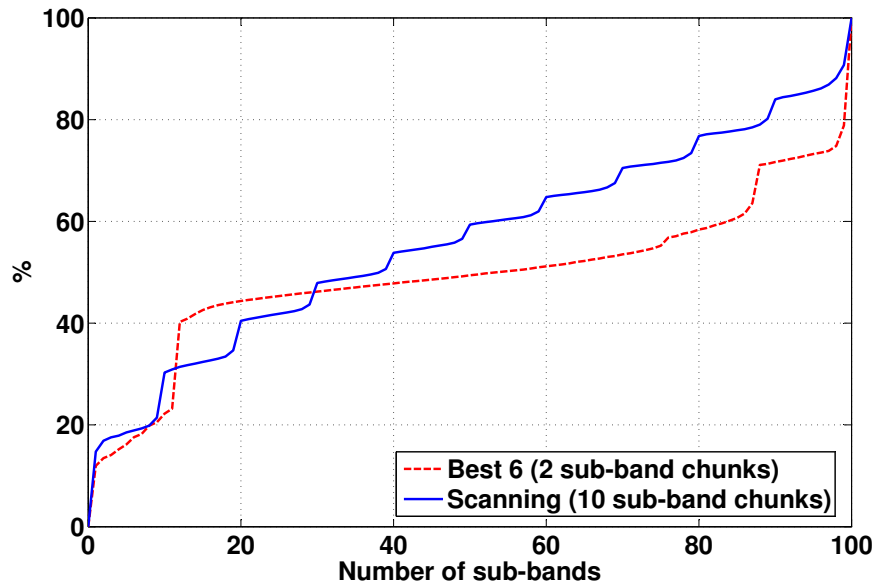

Figure 5.11. CDF over how many chunks a user is assigned for each transmission for two different CQI-compression schemes.

Simulations for chunk-sizes of 4 and 10 sub-bands was also run, but left out of Figure 5.10 for readability. They performed similar to the scheme with 5 sub-band chunks, but slightly worse.

5.7 Limited uplink channel test

To understand how limiting of the uplink, with for example CQI-reports, affects the system performance Figure 5.13 shows the downlink throughput dependent on the uplink capacity. By limiting the number of available symbols in a sub-frame the channel limitation can be studied. In the downlink we have web-traffic with fix packet sizes of 200 kbytes per package and the web-model is also used for the uplink but with packet sizes of 50 kbytes.

Figure 5.13 shows that when the uplink is fully loaded it will severely affect the downlink performance. This is because of the web traffic model and the TCP protocol. The loaded uplink delays TCP acknowledgement package, leading to

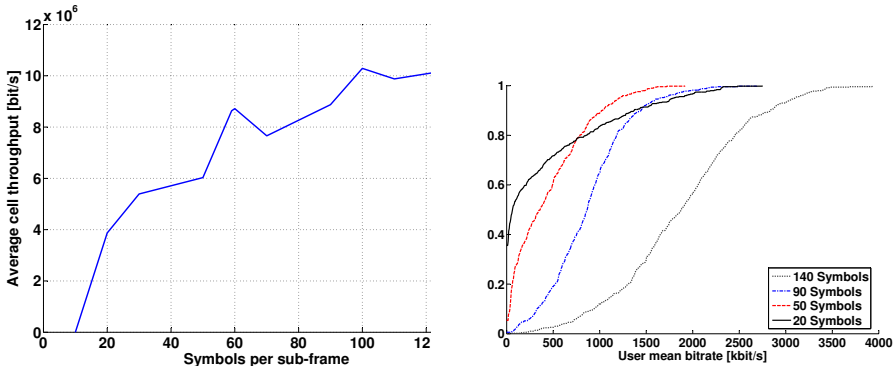

(a) Throughput in uplink with limited channel (b) CDF over user uplink bitrates with limited uplink channel

Figure 5.12. System uplink performance when the uplink becomes more limited

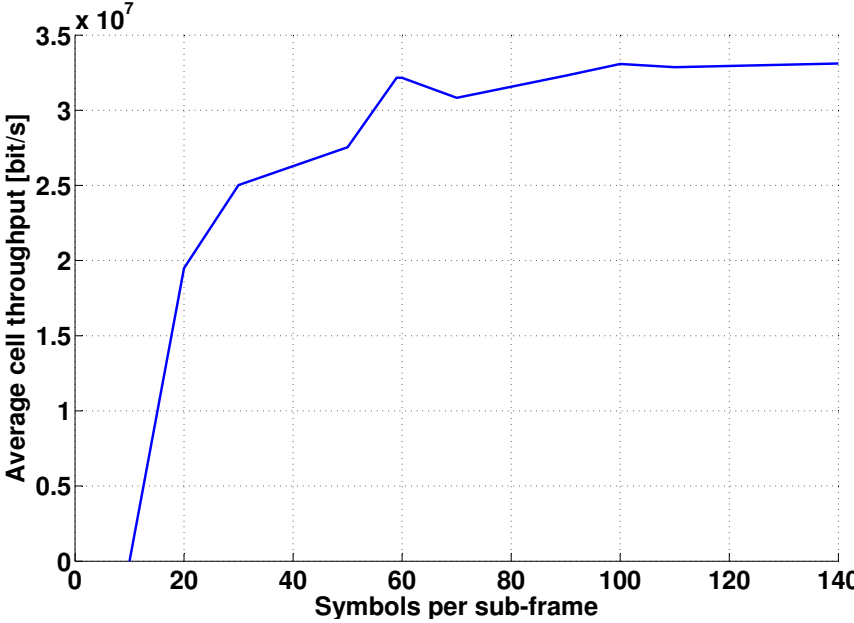

Figure 5.13. Throughput in downlink with increasing uplink size.

both delays and retransmissions. The waiting time for the next package is also longer because of uplink delay, with the delay on the package request.

In Figure 5.12(a) we can see that if the uplink channel is not fully loaded it will not cost much in uplink performance to limit it with CQI-transmissions. This is from the fact that we can remove 20 symbols without losing anything in system throughput. Noted in Figure 5.13 is that when the uplink starts to limit the downlink, at about 100 symbols, we can remove 30 symbols per sub-band and still have a 10 % downlink CDS gain compared to only reporting an average. 30 symbols are approximately 60-90 bits according to Figure 5.5. We saw in Figure 5.9 that with the scanning scheme a UE that reports 60 bits can still have most of the gains from frequency domain channel dependent scheduling. This indicates that if only the downlink performance is of concern it can still be a good idea to transmit large CQI-reports. The symbols reserved for CQI will severely affect the uplink performance. This makes it a balancing dependent on how important the data in the downlink is compared to that in the uplink.

How fast the performance in the uplink decreases and at what load depend highly on the uplink scheduler. In this case a very simple uplink scheduler is used with no channel dependent scheduling. In the CDF over user bitrate, Figure 5.12(b), it is evident that for limited systems users will be dropped for uplink traffic. From the downlink traffic it is evident that only some TCP acknowledgements and packet request packages get through. This is not good and should be avoided, therefore is probably some form of overhead control needed

5.8 Triggers and load test

The final simulations aim to test if it is possible to transport CQI with data and see a gain from it. An increasing number of symbols per sub-frame are allocated for CQI. The same modulation is used for CQI as for data and the code rate is half that of the data. The error probability for CQI-transmissions is set to 0. An average report is sent on PUCCH every fifth TTI, unless it coincides with a transmission on PUSCH. Reports are always sent with data, not only when coinciding with a PUCCH allocation, section 3.4. A new report is only used if it is at least as large as the last one or if the old one is older than 10 ms. Scanning is used, with the granularity dependent on the number of bits. Simulations both with and without the web-traffic in the uplink we conducted. With Data refers to when we have the web-traffic model and With TCP to the situation that the uplink only carry packet requests and TCP-ACKs.

We can see in Figure 5.14(a) it is possible to gain from CQI-transmissions with data. We also see the expected loss in downlink throughput when the uplink gets limited. The gain is not as large as what we saw with full granularity reporting, but we still see an approximate 10% gain even with these poorly controlled reports. At the same number of symbols for CQI, 60, can we see in Figure 5.14(b) a degradation of 8% in the uplink throughput. In Figure 5.15 we can see the CDF over user mean bitrate for 60 symbols taken for CQI. It mainly shows that the drop rate, users without any packages, is very low. We also see that the performance

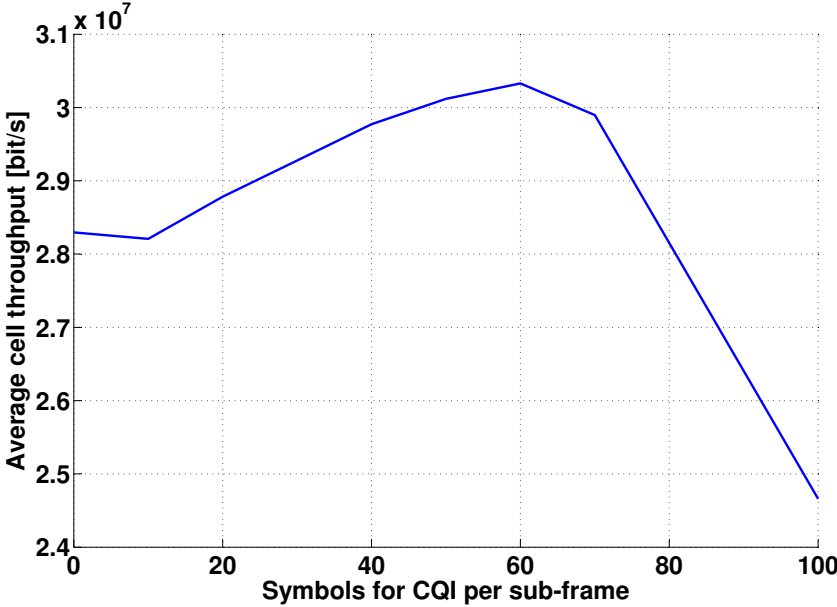

(a) Downlink

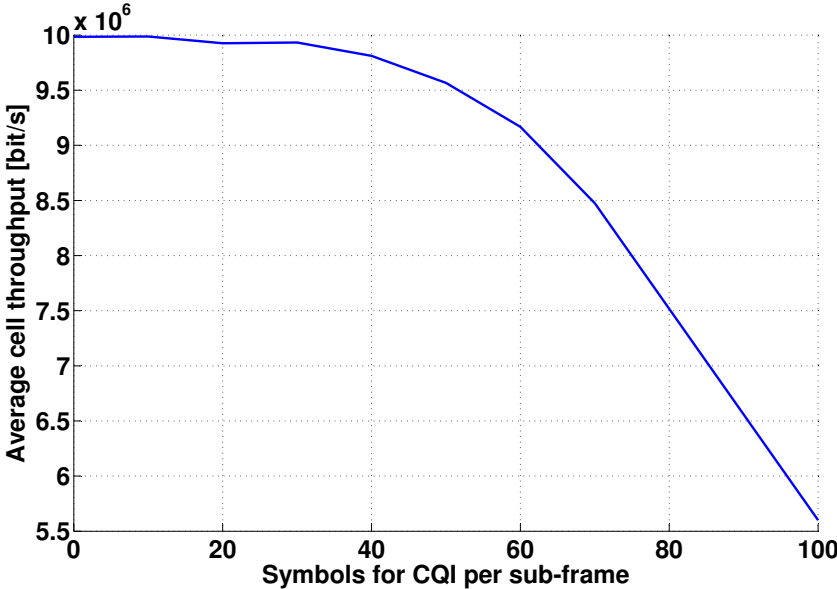

(b) Uplink

Figure 5.14. Throughput dependent on symbols allocated for CQI, limiting the uplink

per user is fairly similar to the full reporting case, Figure 4.1.

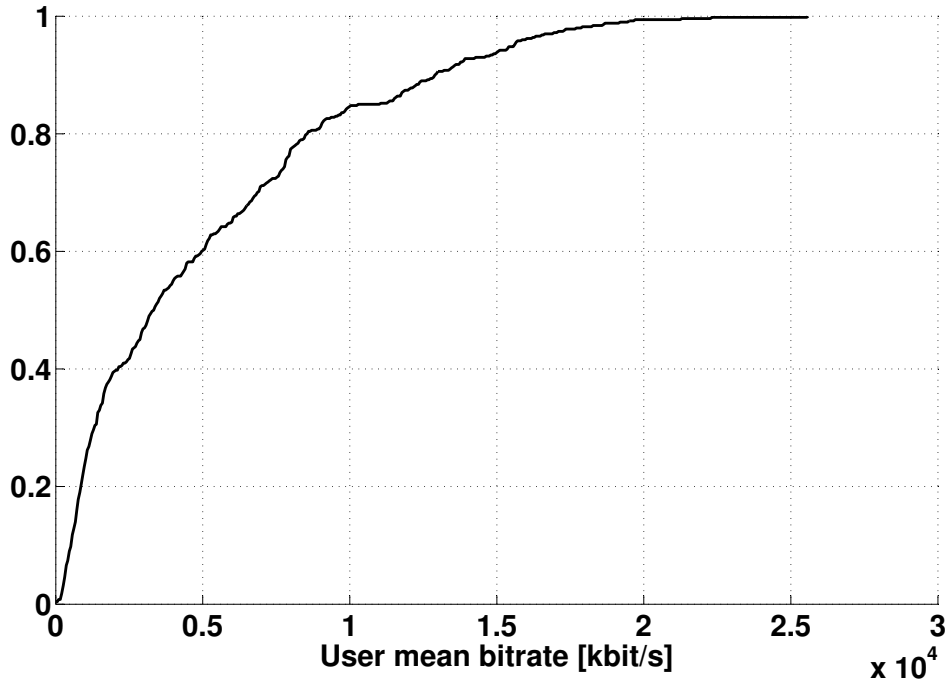

Figure 5.15. CDF over user mean downlink bitrate with 60 symbols reserved for CQI in the uplink.

The technique to send CQI with data demand a certain load of uplink traffic to work properly. In section 3.4 we discussed if the generated TCP acknowledgement packages would be enough. In Figure 5.16 we can see the CDF over the time between two reports. What we can see is that approximately 85% of the reports are delivered in time for the old one not to be obsolete if data is present. This depends much on how much data there is in the uplink. The same percentage for a system without upload data is only 70%. The size of the allocations also varies. When mostly TCP-ACKs are sent users will only get assigned one band, since that's enough to carry their data. In the selected scheme for reporting the size of a report will depend much on the size of the allocation. Figure 5.17 shows the distribution of the report sizes. What is evident is that most reports in the situation without data are too small to be useful, less than 8 bits for an overhead of 10 symbols. 10 symbols is approximately an overhead of 7%. Figure 5.17 also shows that this method for deciding overhead is very inflexible. To get a large portion of the packages to be large enough to be useful a large number of

symbols must be allocated for CQI. With uplink data and 50 symbols for CQI are all packages large enough. This will unfortunately also leads to many packages that are unnecessary large. 45% of all the packages is larger than 100 bits for 50 symbols for CQI with data in the uplink. We saw in section 5.5 that only a small gain can be archived with reports larger then 100 bits. One favorable thing with this kind of reporting is that the size of the overhead is easily estimated. This is why it was chosen for this study.

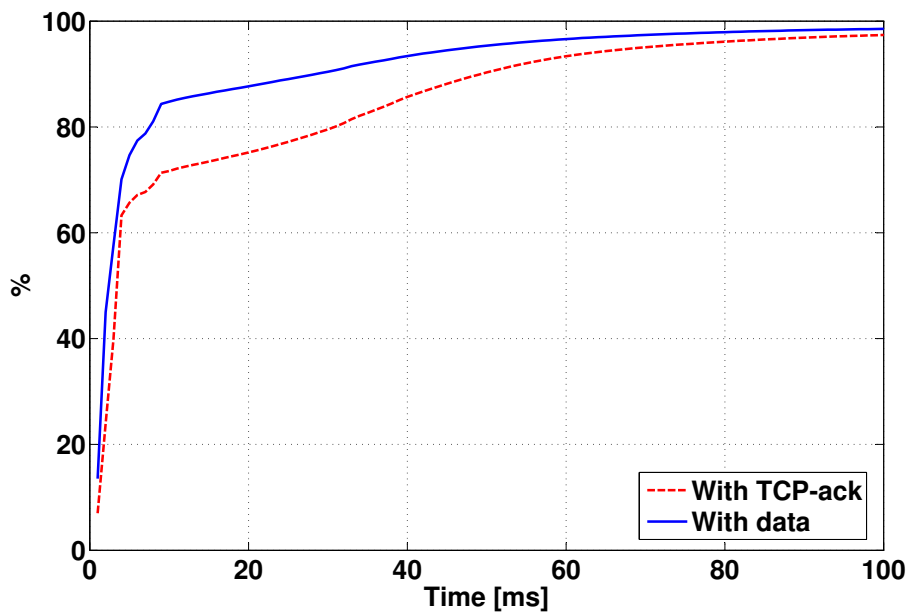

Figure 5.16. CDF over report-ages, 10 symbols reserved for CQI.

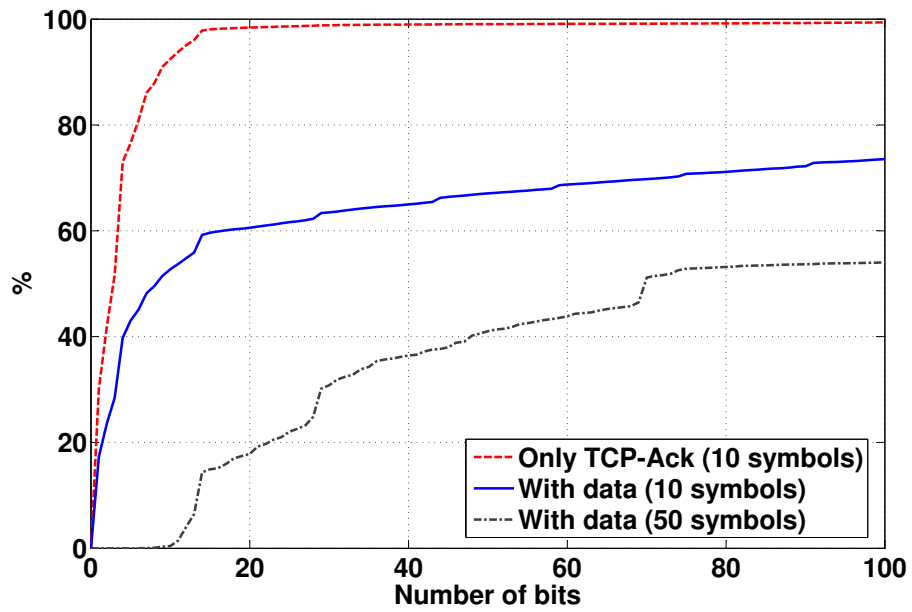

Figure 5.17. CDF over the number of bits each CQI-report contains

Chapter 6

Discussion

6.1 Conclusions

As shown in section 5.1 the potential gain from channel dependent scheduling is significant. An increase in both user-throughput and system capacity can be shown. The gain is larger then presented in the simulations section since the capacity gain is not taken into consideration.

The number of bits needed to get perfect channel knowledge for all users is much to large, but as shown in section 5.5 high gain can be expected from channel dependent scheduling even with only a portion of the bits. How large granularity that is needed depend much on the scenario. The results from the comparison between the two selected compression methods, Best M and Scanning, is found in section 5.6. In the scenario run in section 5, with many users with large packages the scanning scheme was much better, Figure 5.9 and 5.10. Scanning gave better results for almost all numbers of reported bits and is much more scalable for different numbers of bits. This opens for an opportunistic reporting where the granularity depends on how many bits that can get through. This method is used in section 5.8. We can expect that if there are many small packages a Best M scheme can probably be favorable instead. If the load was much higher so users never get assigned more then their pointed out bands Best M can probably also work as good as Scanning.

We saw in section 5.7, Figure 5.13, that the cost of limiting the uplink channel with CQI can be large. In section 5.8 we stated that the loss in the uplink for CQI gave a gain in the downlink throughput. Therefore should the reporting overhead ideally be flexible and depend on the uplink load.

In section 5.3 we showed that to receive a gain from frequency domain CDS must the reporting interval be short, less then 20 ms even for slow moving users. Preferably should it be as short as possible, 5 ms or less. We also saw that for fast moving users fine granular reporting is unnecessary; since they are outdated before they can be used. The granularity needed in a report depends on the coherence bandwidth, which depends on the surroundings, so different granularity can be optimal for different deployments. The coherence bandwidth will even vary

within one cell.

In section 2.11 we discussed measurement errors. This can present itself to be a real problem for the frequency and time channel quality dependent scheduling to work. We saw from section 5.4 that an error of more than 1 dB greatly affects the performance. It has been noted in real WCDMA deployments that the error is around 1 dB, but the measurement-time in 3G is twice as long, 2 ms. This means that the error in a LTE system can be expected to be larger.

In section 5.8 we saw that the concept to send CQI-reports with data works in practice but could be optimized. Without a scheduler to request CQI-reports it is doubtful that we would see much gain if the uplink data was limited. A system where CQI always goes with uplink-data would need large overhead to show significant gain, see Figure 5.14(a). We also saw in section 5.2 that different schedulers gave different performance. Dependent on what is prioritized in a network it can be somewhat controlled by a scheduler.

6.2 Future work

The age of a quality report is of critical importance. The reports should therefore come often and without delays between measurements to when it can be used for scheduling. Some delays for data transmission and processing are inevitable, with data-processing and transmission. A complementary to fast reporting is prediction. Since we have a good notion of the physical phenomenon behind the fast fading, section 2.1, filtering can predict how the channel is going to change in the near future, a few milliseconds [9]. The problem with this is the computational requirements for good estimations. Also the physical models must be good, and might have to be optimized for each location. It would be interesting to study how these predictions affect performance. From Figure 5.7 we can expect low but noticeable improvement for short detection. If we with high accuracy could predict further, 10 to 20 ms, into the future the gains would be substantial. This technique could probably lower the required amount of CQI.

MIMO is a crucial part of LTE, the high performance requirements depend on it. In the simulations run only receiver diversity has been used. An interesting study would be to see how the channel dependent scheduling performs in a MIMO system. It will likely not just scale with the same gain in a multi antenna system. In MIMO the parts of the channel with good quality can be better utilized with multi-layer transmission. This speaks for greater gain with CDS in a MIMO system, but other things might counter this. For example more diversity and beamforming can cancel out channel nulls. A large part of CDS is that we can avoid the poor parts of the channel as much as finding the good parts. Beamforming and MU-MIMO give an extra dimension, and complexity, to the scheduler, giving more potential if it can be utilized.

Only one scenario has been tested in this thesis work. We saw in section 5.1 that the gain from CDS can be scenario dependent. Also the different reporting schemes presented can have different gain for different scenarios. Therefore it would be interesting to study the performance under few other assumptions on

deployment, load and traffic. Also a more accurately limited system would be interesting to study, with the grant limitation in both number and form. The different CQI feedback methods probably have to be optimized dependent on which types of allocations that will be available.

As discussed in the previous section it would be preferred if the scheduler could request reports when needed. The scheduler would then have to take the age of the reports and traffic, both up and down, into consideration for both scheduling and the request for new reports. This kind of scheduler should adapt the uplink CQI overhead so the uplink does not limit the system, but many times it is probably much room left that can be utilized. A simulation with that kind of scheduler should see a gain, but it would be interesting to see if it is enough to motivate the extra complexity. If scheduler and link adaptation consider the age of a report it should probably more accurately reach the BLER target. Maybe some kind of back-off is preferable with old reports. The next step would be to consider the difference in QoS (quality of service), for the present uplink and downlink data, when deciding on CQI-overhead.

Something that is not discussed in this report is what to do with old CQI-reports. In the simulations the old values were just overwritten by the new, independent of size and age of the reports. The exception was in section 5.8 where average reports only were accounted for if the previous report were older than 10 milliseconds. It is clear that information from an old report can be used in a better way. For example if an average over all sub-bands is reported the TTI after a full granular report is received then we should of course not overwrite the large report. How can this new information then be used in an optimal way? The risk to consider is also error propagation in reports if too much weight is counted on old assumptions.

6.3 Final note

It is showed in this report that channel dependent scheduling can give a gain in downlink performance. The gain from doing the scheduling in both time and frequency is substantial. The required reporting interval depends on the movement speed of the user, but should always be as short as possible. We have seen that the granularity of channel quality report does not have to be fine to see a gain, but for reports much larger than the coherence bandwidth the gain is greatly diminished. Finally we saw that the flexibility when and how to transmit reports is important, but gain can be shown for quite simple setups.

Bibliography

- [1] www.3gpp.org.
- [2] 3GPP. Physical layer aspects for evolved universal terrestrial radio access (UTRA) v7.1.0, tr25.814. 2006.
- [3] 3GPP. Requirements for evolved UTRA (E-UTRA) and evolved UTRAN (E-UTRAN) v7.3.0, tr25:913. 2006.
- [4] 3GPP. Deployment aspects v7.0.0, tr25.943. 2007.
- [5] Lars Ahlin, Jens Zander, and Ben Slimane. *Principles of Wireless Communications*. Studentlitteratur, 2006.
- [6] Jörgen Bach Andersen, Theodore S. Rappaport, and Susumu Yoshida. Propagation measurements and models for wireless communications channels. *IEEE Communications Magazine*, January 1995.
- [7] David K. Cheng. *Field and Wave Electromagnetics (Second Edition)*. Addison Wesley, 1989.
- [8] Erik Dahlman, Hannes Ekström, Anders Furuskär, Jonas Karlsson, Michael Meyer, Stefan Parkvall, Johan Torsner, and Mattias Wahlqvist. The long-term evolution of 3G. *Ericsson Review*, 2005.
- [9] Torbjörn Ekman. *Prediction of Mobile Radio Channels*. PhD thesis, Uppsala University, Sweden, 2000.
- [10] Marc Engels. *Wireless OFDM systems: How to make them work?* Kluwer Academic Publishers, 2002.
- [11] Jessica Heyman. Intercell interference management in an OFDM-based downlink. Master's thesis, Linköping University, 2006.
- [12] Kim Hoon and Han Youngnam. A proportional fair scheduling for multicarrier transmission systems. *IEEE Communications Letters*, VI. 9 No. 3, 2005.
- [13] Jonathan H. Manton. Optimal training sequences and pilot tones for OFDM systems. *IEEE Communications Letters*, VI. 5 No. 4, April 2001.

-
- [14] Abdel-Majid Mourad, Loïc Brunel, Akihiro Okazaki, and Umer Salim. Channel quality indicator estimation for OFDMA systems in the downlink. *IEEE Vehicular Technology Conference*, April 2007.
 - [15] Hyung G. Myung. Introduction to single carrier FDMA. *15th European Signal Processing Conference (EUSIPCO)*, September 2007.
 - [16] Spyros J. Papantoniou. A multipath channel model for mobile-radio communications. *IEEE International Symposium on Personal, Indoor and Mobile Radio Communications*, October 1992.
 - [17] A Pokhariyal, T. E. Kolding, and P. E. Mogensen. Performance of downlink frequency domain packet scheduling for the UTRAN long term evolution. *IEEE International Symposium on Personal, Indoor and Mobile Radio Communications*, September 2006.
 - [18] Ericsson Research. E-UTRA incremental CQI reporting using DCT coding. *www.3gpp.org, Conference entry R2-062858*, 2006.
 - [19] Bernard Sklar. Rayleigh fading channels in mobile digital communication systems part I: Characterization. *IEEE Communications Magazine*, July 2007.
 - [20] Bernard Sklar. Rayleigh fading channels in mobile digital communication systems part II: Mitigation. *IEEE Communications Magazine*, July 2007.
 - [21] Christian Wengert, Jan Ohlhorst, Alexander Golitschek, and Edler von Elbwart. Fairness and throughput analysis for generalized proportional fair frequency scheduling in OFDMA. *IEEE Vehicular Technology Conference*, May 2005.
 - [22] Christian Wengert, Jan Ohlhorst, and Alexander Golitschek Edler von Elbwart. Fairness and throughput analysis for generalized proportional fair frequency scheduling in OFDMA. *IEEE Vehicular Technology Conference*, May 2005.
 - [23] Xiaodong Xu, Ya Jing, and Xiaohu Yu. Subspace-based noise variance and SNR estimation for OFDM systems. *Wireless Communications and Networking Conference*, March 2005.
 - [24] Seokhyun Yoon, Changho Suh, Youngkwon Cho, and DS Park. Orthogonal frequency division multiple access with an aggregated sub-channel structure and statistical channel quality measurement. *IEEE Vehicular Technology Conference*, September 2004.

Upphovsrätt

Detta dokument hålls tillgängligt på Internet — eller dess framtida ersättare — under 25 år från publiceringsdatum under förutsättning att inga extraordinära omständigheter uppstår.

Tillgång till dokumentet innebär tillstånd för var och en att läsa, ladda ner, skriva ut enstaka kopior för enskilt bruk och att använda det oförändrat för icke-kommersiell forskning och för undervisning. Överföring av upphovsrätten vid en senare tidpunkt kan inte upphäva detta tillstånd. All annan användning av dokumentet kräver upphovsmannens medgivande. För att garantera äktheten, säkerheten och tillgängligheten finns det lösningar av teknisk och administrativ art.

Upphovsmannens ideella rätt innefattar rätt att bli nämnd som upphovsman i den omfattning som god sed kräver vid användning av dokumentet på ovan beskrivna sätt samt skydd mot att dokumentet ändras eller presenteras i sådan form eller i sådant sammanhang som är kränkande för upphovsmannens litterära eller konstnärliga anseende eller egenart.

För ytterligare information om Linköping University Electronic Press se förlagets hemsida <http://www.ep.liu.se/>

Copyright

The publishers will keep this document online on the Internet — or its possible replacement — for a period of 25 years from the date of publication barring exceptional circumstances.

The online availability of the document implies a permanent permission for anyone to read, to download, to print out single copies for his/her own use and to use it unchanged for any non-commercial research and educational purpose. Subsequent transfers of copyright cannot revoke this permission. All other uses of the document are conditional on the consent of the copyright owner. The publisher has taken technical and administrative measures to assure authenticity, security and accessibility.

According to intellectual property law the author has the right to be mentioned when his/her work is accessed as described above and to be protected against infringement.

For additional information about the Linköping University Electronic Press and its procedures for publication and for assurance of document integrity, please refer to its www home page: <http://www.ep.liu.se/>