

Character Formulae and the Structure of the Representations of the N=1, N=2 Superconformal Algebras ¹

Elias Kiritsis

California Institute of Technology, Pasadena, CA 91125

ABSTRACT

The unitary representations of the N=1 and N=2 superconformal algebras are analyzed. The embedding structure of all the degenerate representations is studied. Character formulae are derived for the degenerate representations including those with $\tilde{c} \geq 1$. The relation between characters and the exact partition functions of 2-d critical statistical systems is explored. The $\tilde{c} = 1/3$, N=2 superconformal system is analyzed from the group theoretic point of view and it is shown to be a subsector of the N=1, $\hat{c} = 2/3$ theory.

Published in Int. J. Mod. Phys. A3 (1988) 1871.

June 1986

¹This work was supported in part by the US Department of Energy under contract No DE-AC0381-ER40050.

1 Introduction

Recently a number of authors, [1,2,3], found the unitary representations of the N=2 superconformal algebras (periodic, antiperiodic and twisted). They derived the formula for the Kač determinant, which renders possible the classification of the unitary, irreducible representations.

The interest in the N=2 algebra is due to various reasons. First, it is the gauge algebra of the U(1) string, [5] and of the N=2 nonlinear σ -models arising from compactifications of ten-dimensional string theories. The N=2 superconformal invariance of the resulting nonlinear σ -model is important because it is associated to the spacetime supersymmetry of the string theory ground state after compactification which should be exact to all orders in the string coupling [6]. Knowledge about the unitary irreducible representations of the N=2 superconformal algebra provides us with some nonperturbative tools that may be used to gain insights in the physics of various compactifications. The algebra arises also in two-dimensional critical statistical systems [7], and in some particular ghost systems [8].

Character formulae are very important for the following two reasons. First, they are an extremely useful tool in the representation theory of these algebras, providing valuable information in the determination of the Clebsch-Gordan series as well as in subgroup decompositions. In fact, in section 5 we use the characters of the N=2 superconformal algebra to decompose N=2 representations with $\tilde{c} = 1/3$ into N=1 representations with $\hat{c} = 2/3$. Second, and most important for physics, they provide direct means to evaluate exactly the partition function of superconformal theories (in particular 2-d critical statistical systems). Information about partition functions is also useful in studying the modular invariance of critical statistical systems. In the particular case of the N=2 superconformal algebras, character formulae give exact information about the partition function of certain representations that arise in N=2 nonlinear σ -models on Ricci-flat manifolds.

The general embedding structure of various representations of the conformal algebra was given by Feigin and Fuchs [9], while Rocha-Caridi derived the character formula for the degenerate representations of the conformal algebra [10]. The character formulae for the degenerate representations of the N=1 superconformal algebra were stated in [11].

In this paper we will analyze the embedding structure among unitary irreducible representations and derive the character formulae for all the degenerate representations of the N=1 and N=2 superconformal algebras. We will also elaborate on the relation between characters and the exact partition functions of 2-d critical statistical systems.

The structure of this paper is as follows. In section 2 we discuss the N=1 superconformal algebras and we derive the embedding patterns of the degenerate representations as well as their characters. In section 3 we discuss the respective subjects for the N=2 superconformal algebras focusing on the $\tilde{c} < 1$ representations. In section 4 we analyze the structure of the N=2 degenerate representations with $\tilde{c} \geq 1$ and we derive their characters. In section 5 we discuss the relation between characters and the exact partition functions of two-dimensional critical statistical systems. A character proof of the equivalence of the $\tilde{c} = 1/3$ N=2 system

and the $\hat{c} = 2/3$ N=1 system is given. Section 6 contains our conclusions. In appendix A we present explicit examples of null highest weight vectors of the N=2 superconformal algebras. Finally in appendix B we derive all relevant N=2 partition functions.

2 N=1 Superconformal Algebras

As a warm-up exercise, we will start from the N=1 algebra which is given by the following (anti)-commutation relations:

$$\begin{aligned} [L_m, L_n] &= (m-n)L_{m+n} + \frac{\hat{c}}{8}(m^3 - m)\delta_{m+n,0} \\ [L_m, G_r] &= \left(\frac{m}{2} - r\right)G_{m+r} \\ [G_r, G_s]_+ &= 2L_{r+s} + \frac{\hat{c}}{2}\left(r^2 - \frac{1}{4}\right)\delta_{r+s,0} \end{aligned} \quad (2.1)$$

The anomaly is normalized such that an N=1 free scalar superfield has $\hat{c} = 1$. It is related to the anomaly of the Virasoro algebra by $\hat{c} = \frac{3}{2}c$. There are two possible N=1 algebras. The Neveu-Schwarz (NS) algebra, where G_r has half-integer modes and the Ramond (R) algebra, where G_r has integer modes (the energy-momentum tensor is always periodic).

The authors of ref. [12] by analyzing the Kač determinant, had given the possible irreducible and unitary representations for $\hat{c} < 1$. They exist only when the anomaly takes the following values:

$$\hat{c} = 1 - \frac{8}{m(m+2)}, \quad m = 2, 3, 4, \dots \quad (2.2)$$

and the possible dimensions of the primary states (highest weight vectors -hvw-) are:

$$h_{p,q} = \frac{[(m+2)p - mq]^2 - 4}{8m(m+2)} + \frac{\epsilon}{16}, \quad 1 \leq p \leq m-1, 1 \leq q \leq m+1, p, q \in Z \quad (2.3)$$

where in the NS-sector $p - q$ is even and $\epsilon = 0$, whereas in the R-sector $p - q$ is odd and $\epsilon = 1$. The Kač determinant for the N=1 algebra, at level n , in the NS-sector is the following [13,14,15]

$$\det M_n = \prod_{1 \leq rs/2 \leq n} (h - h_{r,s}(\hat{c}))^{P_{NS}(n-rs/2)} \quad (2.4)$$

where the product in (2.4) runs over positive integers p, q with $p - q$ even. $P_{NS}(k)$ is the dimension of level k :

$$\sum_{k=0}^{\infty} z^k P_{NS}(k) = \prod_{k=1}^{\infty} \frac{(1 + z^{k-1/2})}{(1 - z^k)} \quad (2.5)$$

For the R-sector, [15]

$$\det(M_0^+) = 1, \quad \det(M_0^-) = h - \frac{\hat{c}}{16} \quad (2.6a)$$

$$\det(M_n^+) = \det(M_n^-) = \left(h - \frac{\hat{c}}{16}\right)^{P_R(n)/2} \prod_{1 \leq rs/2 \leq n} (h - h_{p,q}(\hat{c}))^{P_R(n-rs/2)} \quad n > 0 \quad (2.6b)$$

where the product runs over all positive integers p, q with $p - q$ odd, while $P_R(k)$ is half the dimension of the k th level:

$$\sum_{k=0}^{\infty} z^k P_R(k) = \prod_{k=1}^{\infty} \frac{1+z^k}{1-z^k} \quad (2.7)$$

The superscripts $+, -$ denote the parity of the corresponding hwv under the fermion number operator $(-1)^F$.

A vanishing of a factor in the product representing the Kač determinant in the NS sector for some appropriate integers r, s , implies the existence of a hwv at level $rs/2$ which is embedded in the family $[h]$ and which is a null vector (the correlation functions with itself or any other state vanish).

In order to show the assertion made in the previous paragraph we have to remind the reader what the Kač determinant exactly is. Let O_i be a basis in the subspace of the Verma module such that $L_0 = h + n$. Then the Kač determinant is given by,

$$\det M_n(h, \hat{c}) \equiv \det(\langle O_i O_j \rangle)$$

The vanishing of the Kač determinant implies the existence of an eigenvector with a zero eigenvalue, that is, $M_n^{i,j} v_j = 0$ for a non-zero vector v_i . The fact that this vector is an eigenvector of the matrix $M_n^{i,j}$ (with zero eigenvalue) implies that it is also a hwv of the algebra. Now suppose that $h = h_{r,s}$ for some specific positive integers r, s , such that there are no other pairs of positive integers r', s' with $r's' < rs$. Then $\det(M_{rs/2})$ has a zero factor and there is a *unique* corresponding hwv, (because $P_{NS}(0) = 1$), at level $rs/2$. The existence of such hwv's implies that the representation generated by the hwv (h) is reducible since it contains (at least) the representation generated by the previously mentioned hwv.

In order to derive the character of $[h]$ we have to subtract all the possible representations that are embedded in the Verma module $M(h)$ generated by $[h]$. Consequently we need to study the nesting structure of all the submodules of the initial Verma module, $M(h)$.

We will focus first on the NS sector and in particular on the degenerate unitary representations with $\hat{c} < 1$, [12].

Starting from a hwv whose dimension $h_{p,q}$ is given by (2.3) we have to find the zeros of its Kač determinant, which signal null hwv's embedded in $M(h_{p,q})$. The Kač determinant for $h_{p,q}$ vanishes for,

$$\begin{aligned} r &= nm + p \quad , \quad s = n(m+2) + q \quad , \quad n = 0, 1, 2, \dots \\ r &= nm - p \quad , \quad s = n(m+2) - q \quad , \quad n = 1, 2, 3, \dots \end{aligned} \quad (2.8)$$

The families with dimensions $h = h_{p,q+rs/2}$ are embedded in $M(h)$. Of course this is not enough to guarantee that these families are the only ones that have this property. The strategy

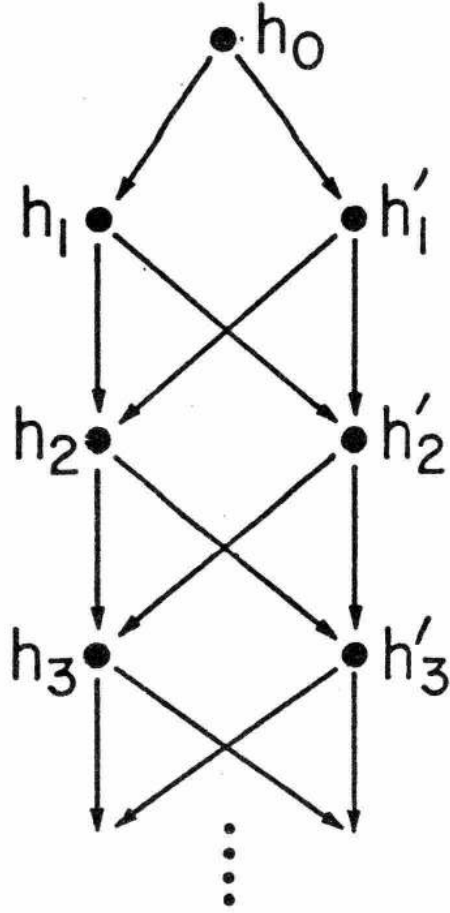

Figure 1: *Embedding diagram for the degenerate representations of $N=1$ unitary minimal models and for T_0 representations of the $N=2$ algebra.*

is to take the family with the lowest dimension and trace again the vanishings of its Kač determinant. Doing that for the first null hwv of dimension

$$h = \frac{[(m+2)p + mq]^2 - 4}{8m(m+2)}$$

we find that its determinant vanishes for,

$$r = nm + p \ , \ s = n(m+2) - q \ , \ n = 1, 2, \dots \quad (2.9)$$

$$r = nm - p \ , \ s = n(m+2) + q \ , \ n = 1, 2, \dots$$

which gives a different set of families.

Continuing this process down and using induction it is relatively easy to show that these are actually all the null hwv's embedded in $M(h)$ and their embedding pattern is the one shown in

fig. 1 (an arrow between two families means that the family at the tip of the arrow is embedded in the family at the end of the arrow).

If we define:

$$r(k) = km + p, \quad s(k) = k(m + 2) + q \quad k \in Z \quad (2.10a)$$

$$r'(k) = km - p, \quad s'(k) = k(m + 2) + q \quad k \in Z \quad (2.10b)$$

then the dimensions of the hwv's of the submodules h_i, h'_i in fig. 1 are given by :

$$\begin{aligned} h_0 &= h_{p,q} \\ h_{2k+1} &= h_{p,q} + \frac{r(k)s(k)}{2}, \quad h'_{2k+1} = h_{p,q} + \frac{r(-k-1)s(-k-1)}{2} \\ h_{2k+2} &= h_{p,q} + \frac{r(0)s(0) + r'(k+1)s'(k+1)}{2}, \\ h'_{2k+2} &= h_{p,q} + \frac{r(0)s(0) + r'(-k-1)s'(-k-1)}{2} \end{aligned} \quad (2.11)$$

The states listed above generate different irreducible representations. Their dimensions are different a fact that can be easily checked.

The character of an irreducible representation h of the N=1 superconformal algebra is defined by:

$$ch(\hat{c}, h, z) = Tr_h[z^{L_0}] \quad (2.12)$$

The trace over all the descendants of a hwv of dimension h is easily computed to be :

$$\chi(h, z) = F_{NS}(z)z^h \quad (2.13)$$

where F_{NS} is the NS partition function,

$$F_{NS}(z) = \prod_{k=1}^{\infty} \frac{1 + z^{k-1/2}}{1 - z^k} \quad (2.14)$$

To compute the character of the irreducible representation generated by $h_{p,q}$, we have to factor out the other families embedded in it. It is obvious from fig. 1 that

$$[h_i] \cap [h'_i] = [h_{i+1}] + [h'_{i+1}] \quad (2.15)$$

and that $[h_{i+1}] + [h'_{i+1}]$ is the largest proper submodule of $[h_i]$ or $[h'_i]$. The character is given by, [9,10],

$$ch(h_0, z) = [h_0] - [h_1] - [h'_1] + [h_1] \cap [h'_1] - \dots = [h_0] + \sum_{i=1}^{\infty} (-1)^i ([h_i] + [h'_i]) \quad (2.16)$$

An easy way to justify (2.16) is the following. We first take the trace over all the descendants of the hwv h_0 . Then we subtract the contribution of the family h_1 and thus we get rid of

everything else in fig. 1 except from the *irreducible* representation generated by h'_1 . The irreducible h'_1 now is given by subtracting h_2 and the irreducible h'_2 . Then (2.16) follows by induction.

Using (2.11),(2.13), eq. (2.15) becomes,

$$ch(h_{p,q}, \hat{c}, z) = F_{NS}(z) \sum_{k \in \mathbb{Z}} [z^{h_{p,q} + \frac{r(0)s(0) + r'(k)s'(k)}{2}} - z^{h_{p,q} + \frac{r(k)s(k)}{2}}] \quad (2.16')$$

Using then (2.10), and after some trivial manipulations, (2.15) takes the form,²

$$\begin{aligned} ch(h_{p,q}, \hat{c}, z) &= F_{NS}(z) \sum_{k \in \mathbb{Z}} [z^{a(k)} - z^{b(k)}] \\ a(k) &= \frac{[2m(m+2)k - (m+2)p + mq]^2 - 4}{8m(m+2)}, \\ b(k) &= \frac{[2m(m+2)k + (m+2)p + mq]^2 - 4}{8m(m+2)} \end{aligned} \quad (2.17)$$

The same remarks apply in the R-sector. The structure of the embeddings is the same as in fig. 1, as well as the dimensions of the hwv's occurring in it. Following the same procedure we end up with the same result as in (2.17) but with $F_R(z)$ replacing $F_{NS}(z)$,

$$F_R(z) = z^{\frac{1}{16}} \prod_{k=1}^{\infty} \frac{1+z^k}{1-z^k} \quad (2.18)$$

This ends our discussion of the character formulas for the degenerate representations of the N=1 superconformal algebras.

3 N=2 Superconformal Algebras, $\tilde{c} < 1$

In this section we will consider the situation in the N=2 superconformal algebra. It is given by the following (anti-)commutation relations³

$$[L_m, L_n] = (m-n)L_{m+n} + \frac{\tilde{c}}{4}(m^3 - m)\delta_{m+n,0}$$

²This is the result stated in [10]. Their formula contains a minor misprint, having $2m(m+1)k$ instead of $2m(m+2)k$ as in (2.17).

³We have chosen a particular normalization for the central charge of the U(1) sub-algebra. It is worth noting that the most general N=2 superconformal algebra includes, up to the freedom of redefinitions, another free parameter, the U(1) charge of the supercharges. Then the respective commutation relations become: $[J_m, G_r^i] = iq\epsilon^{ij}G_{m+r}^j$ and $[G_r^i, G_s^j]_+ = 2\delta^{ij}L_{r+s} + \frac{i}{q}\epsilon^{ij}(r-s)J_{r+s} + \tilde{c}(r^2 - \frac{1}{4})\delta^{ij}\delta_{r+s,0}$. This new parameter does not change the structure of the irreducible representations. Its only effect is to change the distance between successive relative charge levels.

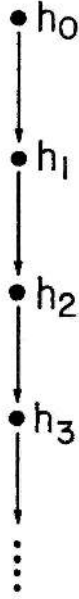

Figure 2: *Embedding diagram for NS_2 , NS_3 degenerate reps, $\tilde{c} > 1$, $q \neq \frac{n}{2}(\tilde{c} - 1) - m$, $n \in \mathbb{Z}$, $m \in \mathbb{Z}_0^+$*

$$\begin{aligned}
[L_m, G_r^i] &= \left(\frac{m}{2} - r\right)G_{m+r}^i, \quad [L_m, J_n] = -nJ_{m+n} \\
[J_m, J_n] &= \tilde{c}m\delta_{m+n,0}, \quad [J_m, G_r^i] = i\epsilon^{ij}G_{m+r}^j \\
[G_r^i, G_s^j]_+ &= 2\delta^{ij}L_{r+s} + i\epsilon^{ij}(r-s)J_{r+s} + \tilde{c}\left(r^2 - \frac{1}{4}\right)\delta^{ij}\delta_{r+s,0}
\end{aligned} \tag{3.1}$$

The normalization of the conformal anomaly is such that a free N=2 scalar superfield has $\tilde{c} = 1$. It is related to the anomaly of the Virasoro algebra by $\tilde{c} = 3c$.

There are three⁴ N=2 algebras corresponding to different modings of the generators. Choosing integer moding for L_m , J_n and half-integer for G_r^i we get the NS-type algebra. If we choose integer moding for all the generators we get the R-type algebra. Finally there is another possibility in this case corresponding to the choice of integer moding for L_m , G_n^1 and half-integer moding for J_r , G_s^2 . This last one gives the Twisted, (T), algebra.

We will start our discussion from the NS algebra and focus on the unitary representations with $\tilde{c} < 1$. In [1] it was shown that these exist only when :

$$\tilde{c} = 1 - \frac{2}{m}, \quad m = 2, 3, 4, \dots \tag{3.2}$$

⁴In fact the NS and R algebras are isomorphic. There is a continuum of N=2 algebras interpolating between these two.

and have hwv's with dimension and U(1) charge q given by,

$$h_{j,k} = \frac{4jk - 1}{4m}, \quad q = \frac{j - k}{m}, \quad j, k \in Z + \frac{1}{2}, \quad 0 < j, k, j + k \leq m - 1 \quad (3.3)$$

Hwv states are labeled by the eigenvalues of the zero modes, L_0 and J_0 , which are the dimension h and the U(1) charge q . Then any descendant is labeled by its level (eigenvalue of L_0 minus h) and its relative charge (eigenvalue of J_0 minus q).

The Kač determinant at level n and relative charge m is given by [1]

$$\det M_{n,m}^{NS}(\tilde{c}, h, q) = \prod_{1 \leq rs \leq 2n}^{s \text{ even}} [f_{r,s}^{NS}]^{P_{NS}(n-rs/2,m)} \times \prod_{k \in Z + \frac{1}{2}} [g_k^{NS}]^{\tilde{P}_{NS}(n-|k|, m - \text{sgn}(k); k)} \quad (3.4)$$

where :

$$f_{r,s}^{NS} = 2(\tilde{c} - 1)h - q^2 - \frac{1}{4}(\tilde{c} - 1)^2 + \frac{1}{4}[(\tilde{c} - 1)r + s]^2, \quad r \in Z^+, \quad s \in 2Z^+ \quad (3.5a)$$

$$g_k^{NS} = 2h - 2kq + (\tilde{c} - 1)(k^2 - \frac{1}{4}), \quad k \in Z + \frac{1}{2}, \quad (3.5b)$$

while the NS partition functions are defined by,⁵

$$\sum_{n,m} P_{NS}(n, m) z^n w^m = \prod_{k=1}^{\infty} \frac{(1 + z^{k-1/2} w)(1 + z^{k-1/2} w^{-1})}{(1 - z^k)^2} \quad (3.6a)$$

$$\sum_{n,m} \tilde{P}_{NS}(n, m; k) z^n w^m = [1 + z^{|k|} w^{\text{sgn}(k)}]^{-1} \sum_{n,m} P_{NS}(n, m) z^n w^m \quad (3.6b)$$

Equation (3.4) implies that whenever there is a vanishing of $f_{r,s}^{NS}$, there exists a unique hwv at level $rs/2$ with the same charge as the initial one, (relative charge zero). When $g_k^{NS} = 0$, there is a hwv at level $|k|$ and relative charge $\text{sgn}(k)$.

Consider the representation of dimension $h_{j,k} = (4jk - 1)/4m$ and charge $q = (j - k)/m$. We will first search for null hwv's at relative charge zero. $f_{r,s}^{NS}$ vanishes for,

$$r = nm \pm (j + k), \quad s = 2n \quad n = 1, 2, \dots \quad (3.7)$$

Thus there are null vectors at relative charge zero, embedded in the family $(h_{j,k}, q)$ their dimensions being $h_{j,k} + n^2 \pm n(j + k)$. We can show that the above hwv's exhaust all null hwv's at relative charge zero. In fact if we order them in order of increasing dimension,

$$h_{2n-1} = h_{j,k} + n^2 m - n(j + k) \quad n = 1, 2, \dots \quad (3.8)$$

$$h_{2n} = h_{j,k} + n^2 m + n(j + k) \quad n = 0, 1, 2, \dots$$

we can show by analyzing the Kač determinant for h_i , that (still at relative charge zero), the families h_j $j > i$ (and only these) are embedded in h_i .

⁵The derivation of the partition functions can be found in App. A.

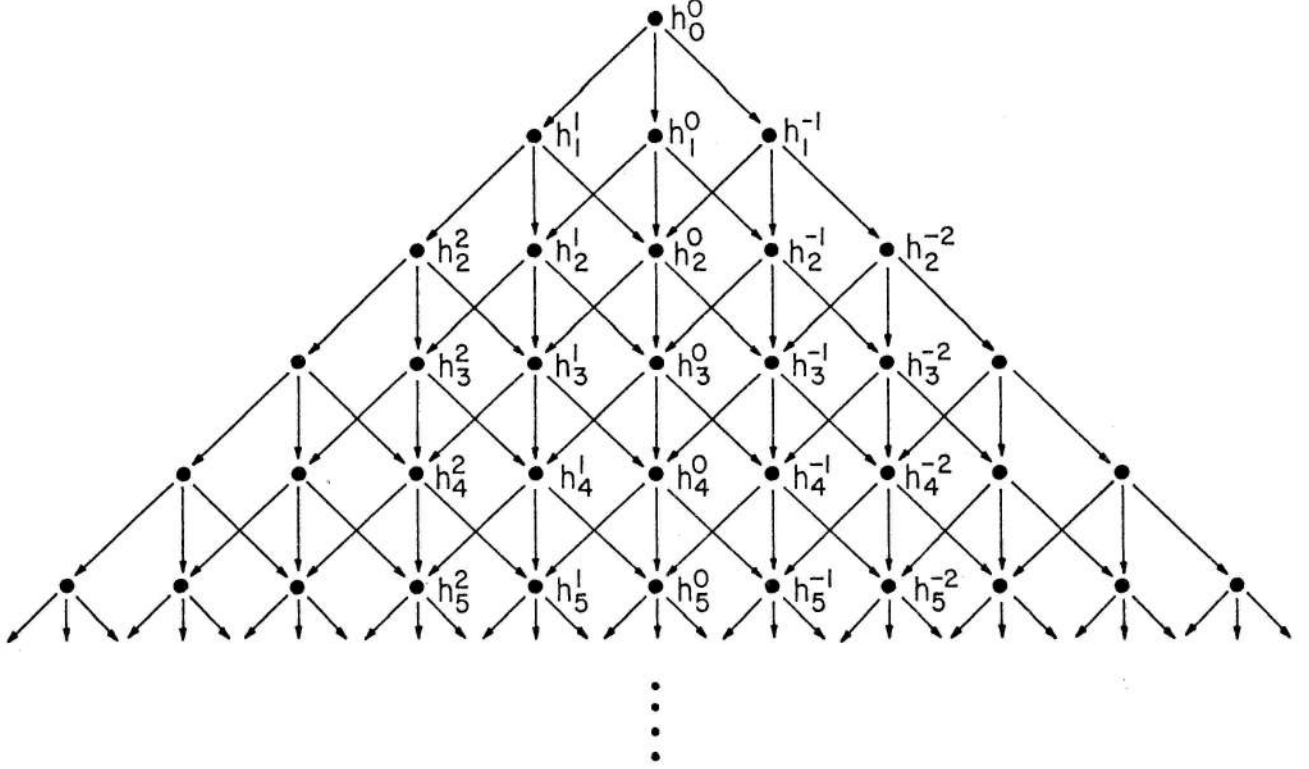

Figure 3: *Embedding diagram for NS_0 degenerate reps, $\tilde{c} = 1 - \frac{2}{m}$*

Next we have to look for null vectors of non-zero relative charge. For $h_{j,k} g_l^{NS}$ vanishes for $l = k$ and $l = -j$. This implies the existence of a hwv of dimension $h_{j,k} + k$ and charge $q + 1$ as well as a hwv of dimension $h_{j,k} + j$ and charge $q - 1$ embedded in $[h_{j,k}]$.

Looking now at the Kač determinant (relative charge zero), of the hwv $h'_1 = h_{j,k} + k$, $q'_1 = q + 1$, we can establish that it vanishes for,

$$r = (n + 1)m + (j + k) \quad , \quad s = 2n \quad n = 1, 2, \dots \quad (3.9)$$

$$r = nm - (j + k) \quad , \quad s = 2(n + 1) \quad n = 1, 2, \dots$$

implying the existence of another series of null hwv's with dimensions,

$$h'_{2n-1} = h_{j,k} + n(n + 1)m - (n + 1)j - nk \quad n = 1, 2, \dots \quad (3.10)$$

$$h'_{2n} = h_{j,k} + n(n + 1)m + nj + (n + 1)k \quad n = 1, 2, \dots$$

and charge $q + 1$.

This scenario continues so that by using induction we can establish the existence of an embedding pattern shown in fig. 3. All embedding diagrams are commutative.

The maps between sectors of different charge form exact sequences due to the fermionic nature of the generating operators. There is unique hwv at each level and charge since the Kač determinant has a simple zero corresponding to that hwv. The dimensions and charges of the various families depicted on it are,

$$h_{2n+l}^l = h_{j,k} + n(n+l)m + n(j+k) + lk, \quad l \geq 0, \quad n \geq 0 \quad (3.11a)$$

$$h_{2n+l-1}^l = h_{j,k} + n(n+l)m - (n+l)(j+k) + lk, \quad l \geq 0, \quad n \geq 1$$

$$h_{2n+l}^{-l} = h_{j,k} + n(n+l)m + n(j+k) + lj, \quad l \geq 0, \quad n \geq 0 \quad (3.11b)$$

$$h_{2n+l-1}^{-l} = h_{j,k} + n(n+l)m - (n+l)(j+k) + lj, \quad l \geq 0, \quad n \geq 1$$

$$q_n^l = q + l, \quad l \in Z$$

It is obvious from (3.11) that all dimensions in a given charge sector are different so that the corresponding representations are distinct.

We define the character of the irreducible representation generated by the hwv of dimension $h_{j,k} = \frac{4jk-1}{4m}$ and charge $q = \frac{j-k}{m}$ ($m \geq 2, 0 < j, k, j+k \leq m-1, j, k \in Z + \frac{1}{2}$) by :

$$ch(h_{j,k}, \tilde{c}, z, w) \equiv Tr[z^{L_0} w^{J_0}] \quad (3.12)$$

The trace over all the descendants of a hwv, (h, q) , is given by⁶

$$\chi(h, q, z, w) = \bar{F}_{NS}(z, w) z^h w^q \quad (3.13)$$

$$\bar{F}_{NS}(z, w) = \prod_{k=1}^{\infty} \frac{(1 + z^{k-1/2} w)(1 + z^{k-1/2} w^{-1})}{(1 - z^k)^2} \quad (3.14)$$

Our task now is to compute the trace by excluding all superconformal families that are embedded in $h_{j,k}$. The procedure is qualitatively the same as in the N=1 case. It is obvious from the embedding pattern pictured in fig. 3 that,

$$[h_i^0] \cap [h_i^1] = [h_{i+1}^0] + [h_{i+1}^1], \quad [h_i^0] \cap [h_i^{-1}] = [h_{i+1}^0] + [h_{i+1}^{-1}] \quad (3.15)$$

$$[h_i^1] \cap [h_i^{-1}] = [h_{i+1}^0], \quad [h_i^0] \cap [h_i^1] \cap [h_i^{-1}] = [h_{i+1}^0] \quad (3.15')$$

The largest proper submodule of h_0^0 is $[h_1^0] + [h_1^1] + [h_1^{-1}]$. The largest proper submodule of $[h_1^0] + [h_1^1] + [h_1^{-1}]$ is given by:

$$[h_1^0] \cap [h_1^1] + [h_1^0] \cap [h_1^{-1}] + [h_1^1] \cap [h_1^{-1}] - 2[h_1^0] \cap [h_1^1] \cap [h_1^{-1}]$$

which is equal to $[h_2^0] + [h_2^1] + [h_2^{-1}]$. Inductively, the largest proper submodule of $[h_i^0] + [h_i^1] + [h_i^{-1}]$ is $[h_{i+1}^0] + [h_{i+1}^1] + [h_{i+1}^{-1}]$. Consequently the character for the irreducible representation $[h_0^0]$ is given by:

$$ch[h_0^0] = \chi([h_0^0]) + \sum_{i=1}^{\infty} (-1)^i \chi([h_i^0] + [h_i^1] + [h_i^{-1}]) \quad (3.16)$$

⁶See App. B.

where χ denotes the unrestricted trace defined by (3.13).

In order to write down an explicit formula for the character we need also the partition functions for single charged fermions⁷

Substituting in (3.16) we get,

$$\begin{aligned}
ch(h_{j,k}, z, w) &= \bar{F}_{NS}(z, w) z^{h_{j,k}} w^q [1 + f_1(z, w) - f_2(z, w)] \quad (3.17) \\
f_1(z, w) &= \sum_{n=1}^{\infty} \left[z^{n^2 m + n(j+k)} + \frac{z^{n(n+1)m - (n+1)(j+k) + k} w}{1 + z^{nm-j} w} + \frac{z^{n(n+1)m - (n+1)(j+k) + j} w^{-1}}{1 + z^{nm-k} w^{-1}} \right] \\
f_2(z, w) &= \sum_{n=0}^{\infty} \left[z^{(n+1)^2 m - (n+1)(j+k)} + \frac{z^{n(n+1)m + n(j+k) + k} w}{1 + z^{nm+k} w} + \frac{z^{n(n+1)m + n(j+k) + j} w^{-1}}{1 + z^{nm+j} w^{-1}} \right]
\end{aligned}$$

Let's now consider the R-sector of the algebra. The zero modes are L_0, J_0, G_0^i . Hwv's are labeled by their dimension, h , charge, $q \pm 1/2$, and chirality, $+, -$. They satisfy also the additional condition, $(G_0^1 \pm iG_0^2)|h, q \pm 1/2 \rangle_{\pm} = 0$. The representations of different chirality are isomorphic to each other under charge conjugation. We are focusing again on $\tilde{c} < 1$. As it was shown in [1], unitary representations occur only when,

$$\tilde{c} = 1 - \frac{2}{m}, \quad m = 2, 3, 4, \dots \quad (3.18)$$

with dimensions and charges given by,

$$h = \frac{\tilde{c}}{8} + \frac{jk}{m}, \quad q = \pm \frac{j-k}{m}, \quad j, k \in Z, \quad 0 \leq j-1, k, j+k \leq m-1 \quad (3.19)$$

From now on we restrict to $+$ chirality since the two representations are isomorphic. The Kač determinant in this case is,

$$\det M_{n,m}^R(\tilde{c}, h, q) = \prod_{1 \leq rs \leq n}^{s \text{ even}} [f_{r,s}^R]^{P_R(n-rs/2, m)} \times \prod_{k \in Z} [g_k^R]^{\tilde{P}_R(n-|k|, m - \text{sgn}(k); k)} \quad (3.20)$$

$$f_{r,s}^R(\tilde{c}, h, q) = 2(\tilde{c}-1)(h - \frac{\tilde{c}}{8}) - q^2 + \frac{1}{4}[(\tilde{c}-1)r + s]^2, \quad r \in Z^+, \quad s \in 2Z^+ \quad (3.21)$$

$$g_k^R = 2h - 2kq + (\tilde{c}-1)(k^2 - \frac{1}{4}) - \frac{1}{4}, \quad k \in Z \quad (3.22)$$

and the Ramond partition functions are defined by,⁸

$$\sum_{n,m} P_R(n, m) z^n w^m = (w^{1/2} + w^{-1/2}) \prod_{k=1}^{\infty} \frac{(1 + z^k w)(1 + z^k w^{-1})}{(1 - z^k)^2} \quad (3.23a)$$

$$\sum_{n,m} \tilde{P}_R(n, m; k) z^n w^m = [1 + z^{|k|} w^{\text{sgn}(k)}]^{-1} \sum_{n,m} P_R(n, m) z^n w^m \quad (3.23b)$$

⁷For a derivation see app. A

⁸See App. B

$Sgn(k) = 1$ if $k > 0$, -1 if $k < 0$ and $sgn(0) = 1$ for the chirality + algebra, -1 for the chirality - algebra.

A vanishing of $f_{r,s}^R$ signals the existence of a hww embedded in the family (h, q) at level $rs/2$ and relative charge $-1/2$, which means that it has the same J_0 eigenvalue as the initial hww. When $g_k^R = 0$, there is a hww at level $|k|$ and relative charge $-1/2sgn(0) + sgn(k)$. The embedding structure for the R algebra is the same as in the NS algebra (fig. 3).

Taking the trace of $z^{L_0}w^{J_0}$ over the whole set of secondaries of the primary field (h, q) we obtain ⁹

$$Tr[z^{L_0}w^{J_0}] = z^h w^q \bar{F}_R(z, w) \quad (3.24)$$

$$\bar{F}_R(z, w) = [w^{1/2} + w^{-1/2}] \prod_{k=1}^{\infty} \frac{(1 + z^k w)(1 + z^k w^{-1})}{(1 - z^k)^2} \quad (3.25)$$

The character in the Ramond sector is the same as in the NS sector modulo the trivial substitution $\bar{F}_{NS} \rightarrow \bar{F}_R$.

For the Twisted algebra the zero modes are L_0 and G_0^1 . Their eigenvalues characterize hww's. Each level contains two equal subspaces of fermion number $(-1)^F = \pm 1$. The Kač determinant for the T-algebra is the following [1],

$$\det M_{+,0}^T = 1, \quad \det M_{-,0}^T = h - \frac{\tilde{c}}{8}$$

$$\det M_{\pm,n}^T(\tilde{c}, h) = [h - \frac{\tilde{c}}{8}]^{P_T(n)/2} \prod_{1 \leq rs \leq 2n}^{s \text{ odd}} [f_{r,s}^T]^{P_T(n-rs/2)} \quad (3.26)$$

$$f_{r,s}^T = 2(\tilde{c} - 1)(h - \frac{\tilde{c}}{8}) + \frac{1}{4}[(\tilde{c} - 1)r + s]^2, \quad s = 1, 3, 5, \dots \quad (3.27)$$

$$\sum_n P_T(n) z^n = \prod_{k=1}^{\infty} \frac{(1 + z^k)(1 + z^{k-1/2})}{(1 - z^k)(1 - z^{k-1/2})} \equiv \bar{F}_T(z) \quad (3.38)$$

The unitary representations of the T-algebra with $\tilde{c} < 1$ are given by,

$$\tilde{c} = 1 - \frac{2}{m}, \quad h = \frac{\tilde{c}}{8} + \frac{(m - 2r)^2}{16m}, \quad m = 2, 3, \dots, \quad r \in Z, \quad 1 \leq r \leq \frac{m}{2} \quad (3.29)$$

Only even m allows the state $h = \frac{\tilde{c}}{8}$, the presence of which implies that supersymmetry is unbroken.

The vanishing of $f_{r,s}^T$ signals the existence of two hww's at level $rs/2$ and fermion parity ± 1 . At level zero there is only one vanishing whereas for each of the higher levels there are two vanishings corresponding to states of opposite parity. Analyzing the vanishings of $f_{r,s}^T$, we can easily show that the embedding pattern is the one shown in fig. 1 with,

$$h_0 = \frac{\tilde{c}}{8} + \frac{(m - 2r)^2}{16m}$$

⁹See App. B

$$h_k = \frac{\tilde{c}}{8} + \frac{[(2k-1)m+2r]^2}{16m}, \quad h'_k = \frac{\tilde{c}}{8} + \frac{[(2k+1)m-2r]^2}{16m} \quad (3.30)$$

The character formula in this case is written down in the same way as in the N=1 case.

$$ch_{m,r}^T(z) = F_T(z) z^{\frac{\tilde{c}}{8}} \left[\sum_{k \in 2Z} (-1)^{k/2} z^{\frac{[(k+1)m-2r]^2}{16m}} \right] \quad (3.31)$$

When $h = \frac{\tilde{c}}{8}$, one of the two states of different chirality is degenerate at the zeroth level and decouples as it can be easily seen from the formula for the Kač determinant. Then supersymmetry is unbroken due to the non-vanishing of the Witten index.

The above complete the derivation of the character formulae for the degenerate representations of the N=2 superconformal algebras with $\tilde{c} < 1$.

A construction of these representations using free fermions has been given, [2], proving their unitarity through an explicit unitary construction of their Hilbert space.

4 N=2 Superconformal Algebras, $\tilde{c} \geq 1$.

The NS and R^\pm algebras contain another class of degenerate representations with $\tilde{c} \geq 1$. We will focus first on the NS sector. There we have two distinct sets of degenerate representations.

NS₂ representations. (the subscript indicates the dimension of their moduli space). A representation in this class is unitary and degenerate if $g_{n_0}^{NS} = 0$ for some $n_0 \in Z + \frac{1}{2}$, $g_{n_0+sgn(n_0)}^{NS} < 0$ and $f_{1,2}^{NS} \geq 0$. According to (3.5b) the first condition implies that,

$$2h = 2n_0q - (\tilde{c} - 1)(n_0^2 - \frac{1}{4}) \quad (4.1)$$

We will suppose for the moment that $n_0 > 0$. Then the second condition implies that,

$$q > (n_0 + \frac{1}{2})(\tilde{c} - 1) \quad (4.2)$$

whereas the third condition implies,

$$-\frac{(\tilde{c} + 1)}{2} + n_0(\tilde{c} - 1) \leq q \leq \frac{(\tilde{c} + 1)}{2} + n_0(\tilde{c} - 1) \quad (4.3)$$

Collecting everything together, the three conditions boil down to (4.1) and

$$(n_0 + \frac{1}{2})(\tilde{c} - 1) < q \leq (n_0 + \frac{1}{2})(\tilde{c} - 1) + 1 \quad (4.4)$$

and it is obvious that both h and q are positive. If $n_0 < 0$ then (4.4) is replaced by :

$$(n_0 - \frac{1}{2})(\tilde{c} - 1) - 1 \leq q < (n_0 - \frac{1}{2})(\tilde{c} - 1) \quad (4.5)$$

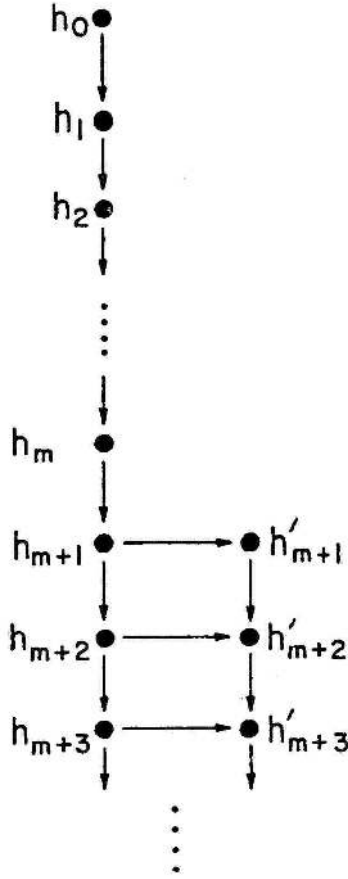

Figure 4: *Embedding diagram for NS_2 degenerate reps, $\tilde{c} > 1$, irrational, $q = \frac{n}{2}(\tilde{c} - 1) - m$, $m, n \in \mathbb{Z}$*

which in particular implies $h > 0$, $q < 0$ in this case. In the following we will discuss the $n_0 > 0$ case and we will point out in the end the appropriate changes for $n_0 < 0$.

As it turns out to be, the embedding structure of these representations depends crucially on the values of \tilde{c} and q , (constrained already by (4.4)). We have to distinguish the following cases:

- (A). $\tilde{c} > 1$, \tilde{c} *irrational*. We will analyze first the interior of the interval (4.4).
- (i) The $U(1)$ charge q has the form, $q = \frac{1}{2}n(\tilde{c} - 1) - m$, $n \in \mathbb{Z}$, $m \in \mathbb{Z}_0^+$ with n constrained from (4.4) :

$$2n_0 + 1 + \frac{2m}{\tilde{c} - 1} < n \leq 2n_0 + 1 + \frac{2(m + 1)}{\tilde{c} - 1} \quad (4.6)$$

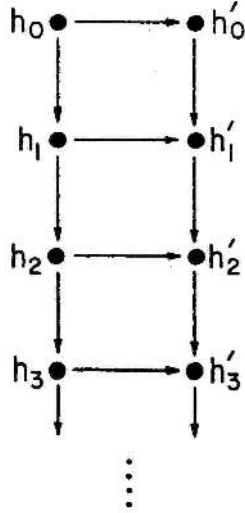

Figure 5: *Embedding diagram for NS_2 degenerate representations, $\tilde{c} > 1$ irrational $q = (n_0 + \frac{1}{2})(\tilde{c} - 1) + 1$.*

Then it is easy to show that the embedding pattern is the one shown in fig. 4 with,

$$h_k = h_0 + kn_0, \quad h'_{m+k} = h_0 + k(n - n_0), \quad q_k = q'_k = q + k \quad (4.7)$$

It is obvious that in a given charge sector the various dimensions are distinct and thus the corresponding representations different. Also the maps from one charged sector to another generate exact sequences due to the fermionic nature of the operators generating the relevant hww's. Another remark is in order here concerning the embedding diagrams: embedding maps that are factorizable have been omitted from the figures. For example in fig. 4 the family h_m contains also a degenerate vector generating h'_{m+1} . Thus the embedding map $f : h_m \rightarrow h'_{m+1}$ is the composition of the maps $g_1 : h_m \rightarrow h_{m+1}$ and $g_2 : h_{m+1} \rightarrow h'_{m+1}$, that is $f(x) = g_2(g_1(x))$. Similar remarks are true for the rest of the embedding diagrams.

The trace over all the descendants of the primary state $|h, q\rangle$ is given¹⁰

$$Tr[z^{L_0} w^{J_0}] = \bar{F}_{NS}(z, w) z^h w^q \quad (4.8a)$$

whereas the trace, for example, over all the descendants of the family (h_1, q_1) is given by,

$$Tr_{h_1}[z^{L_0} w^{J_0}] = \frac{\bar{F}_{NS}(z, w)}{1 + z^{n_0} w} \quad (4.8b)$$

To compute the character in this case we have to subtract the contribution from the family (h_1, q_1) so that,

$$ch(h, q, z, w) = \bar{F}_{NS}(z, w) z^h w^q \left[1 - \frac{z^{n_0} w}{1 + z^{n_0} w} \right] = \bar{F}_{NS}(z, w) \frac{z^h w^q}{1 + z^{n_0} w} \quad (4.9)$$

¹⁰See Appendix B.

- (ii) q has any other allowable value except the ones mentioned in (i). In this case the embedding pattern is shown in fig. 2. The relevant dimensions are,

$$h_k = h + kn_0, \quad q_k = q + k \quad (4.10)$$

so that the character is given again by (4.9).

Let's now consider the representation which lies on the vanishing surface $f_{1,2}^{NS} = 0$, whose charge is given by $q = (\tilde{c} - 1)(n_0 + \frac{1}{2}) + 1$. In this case there is also a null hwv at relative charge zero embedded in the initial representation at the first level. The relevant diagram is given in fig. 5. The corresponding dimensions are,

$$h_k = h + kn_0, \quad h'_k = h + k(n_0 + 1) + 1, \quad q_k = q'_k = q + k \quad (4.11)$$

To evaluate the character in this case we subtract first the family h_1 so that we factor out everything else except the irreducible family h'_0 . This is given by subtracting h'_1 off h'_0 . Consequently,

$$ch(z, w) = \chi([h_0] - [h_1] - [h'_0] + [h'_1]) = \bar{F}_{NS}(z, w) \frac{z^h w^q (1 - z)}{(1 + z^{n_0} w)(1 + z^{n_0+1} w)} \quad (4.12)$$

- (B) $\tilde{c} > 1$, \tilde{c} rational. Then there is a unique way to write \tilde{c} as,

$$\tilde{c} = 1 + \frac{2r_2}{r_1}, \quad r_1, r_2 \in \mathbb{Z}, \quad r_1 \geq 1, \quad r_2 \geq 1 \quad (4.13)$$

and with r_2 being the least positive integer such that (4.13) is true. For $r_2 = 1$ this corresponds to the special class of representations found in [1], which are identified by triple intersections of vanishing surfaces.

We will focus first on representations which are contained in the interior of the interval (4.4).

- (i) If $q = \frac{1}{2}n(\tilde{c} - 1) - m$, $n \in \mathbb{Z}$, $m \in \mathbb{Z}_0^+$ with the integer n constrained by (4.6), then there are three possible embedding patterns corresponding to the following situations.
- (ia) $r_2 > 1$. The corresponding diagram in this case is displayed in fig. 6. The pattern repeats itself with "period" r_2 , and the relevant dimensions are,

$$\begin{aligned} h_k &= h + kn_0, \quad h'_{m+k} = h + k(n - n_0), \quad q_k = q'_k = q + k \\ h''_{k+m+r_2} &= h + (r_2 - k)n_0 + k(n + r_1), \quad q''_k = q + k, \quad k \leq r_2 \\ h'''_{k+m+r_2} &= h + r_2(n - n_0) + k(n_0 + r_1), \quad q'''_k = q + k, \quad k \leq r_2 \end{aligned} \quad (4.14)$$

At each relative charge level all the dimensions are different and correspond to different hwv's.

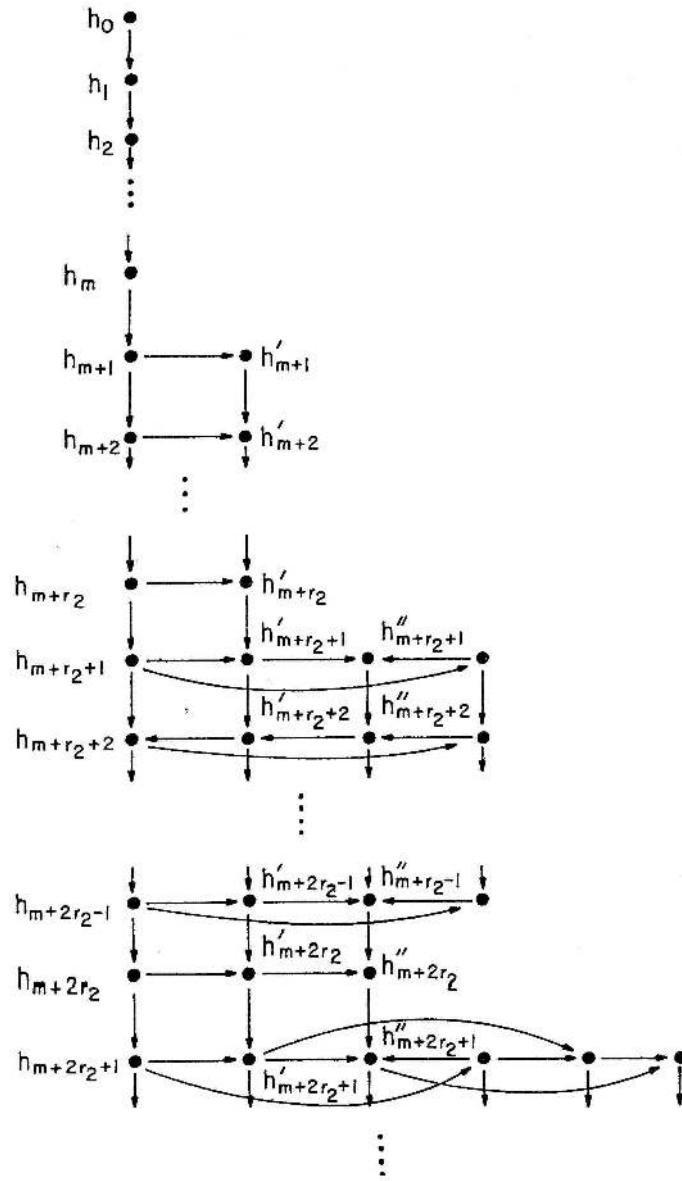

Figure 6: *Embedding diagram for NS_2 degenerate representations, $\tilde{c} = 1 + 2\frac{r_2}{r_1} > 1$, $q = \frac{n}{2}(\tilde{c} - 1) - m, m, n \in \mathbb{Z}$*

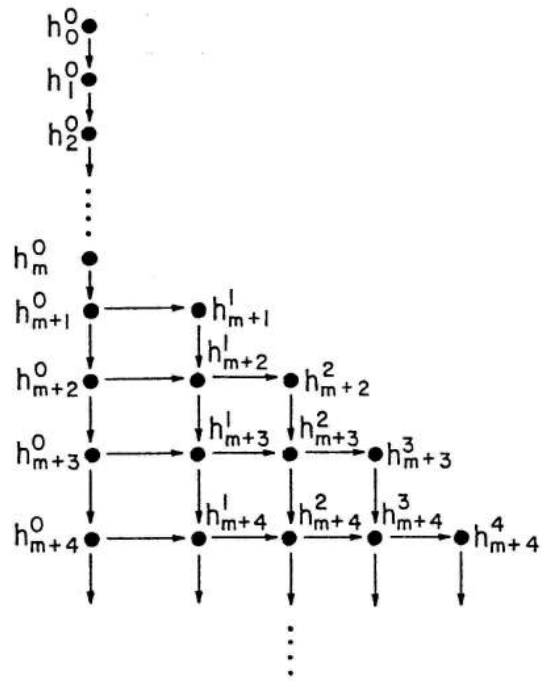

Figure 7: *Embedding diagram for NS_2 degenerate reps, $\tilde{c} = 1 + 2\frac{r_2}{r_1}$, $r_2 = 1$, $n \neq 2n_0 + r_1$, $q = \frac{n}{2}(\tilde{c} - 1) - m$*

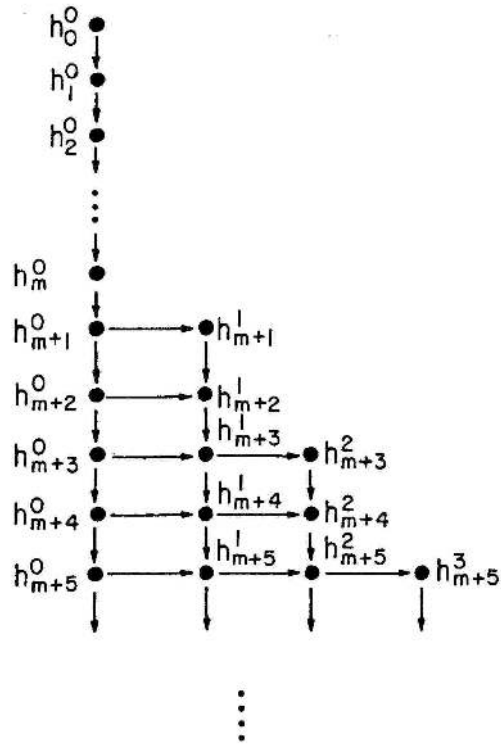

Figure 8: *Embedding diagram for NS_2 degenerate reps, $\tilde{c} = 1 + 2\frac{r_2}{r_1}$, $r_2 = 1$, $n = 2n_0 + r_1$, $q = \frac{n}{2}(\tilde{c} - 1) - m$, $m \in \mathbb{Z}$*

- (ib) $r_2 = 1$, $n \neq 2n_0 + r_1$. Then the diagram of fig. 6 simplifies to the one shown in fig. 7. The dimensions and charges are given by,

$$\begin{aligned}
h_{m+k}^{2l-1} &= h + (k-l+1)[n + (l-1)r_1] + (m+2l-k-2)n_0, \quad 1 \leq l \leq [k + \frac{1}{2}] \\
h_{m+k}^{2l} &= h + l[n + (k-l)r_1] + (m+k-2l)n_0, \quad 1 \leq l \leq [\frac{k}{2}] \\
h_k^0 &= h + kn_0, \quad k \geq 0, \quad q_k^l = q + k
\end{aligned} \tag{4.15}$$

- (ic) $r_2 = 1$, $n = 2n_0 + r_1$. In this case the diagram on fig. 7 collapses even further to the diagram shown in fig. 8, the relevant dimensions being,

$$h_{m+k}^l = h + l(k-l+1)n + [2(l-k)(l-1) + m-k]n_0, \quad q_k^l = q + k \tag{4.16}$$

- (ii) The charge q is not of the form (i). Then the embedding diagram is very simple and it is shown in fig. 2.

In all the cases discussed above the character can be computed by subtracting the contribution of the first embedded family. Consequently the character is given by (4.9).

Let's now consider the representation that lies on the $f_{1,2}^{NS} = 0$ surface with $q = (n_0 + \frac{1}{2})(\tilde{c} - 1) + 1$.

- (a) For $r_1 > 1$, $r_2 > 1$ the embedding pattern is shown in fig. 9, the relevant dimensions being,

$$\begin{aligned}
h_k &= h + kn_0, \quad h'_k = h + kn_0 + k + 1, \quad q_k = q'_k = q + k \\
h''_{k+r_2} &= h + (r_2+k)n_0 + (k+1)r_1 + r_2, \quad h'''_{k+r_2} = h + (r_2+k)n_0 + (k+1)(r_1+1)
\end{aligned} \tag{4.17}$$

- (b) $r_2 = 1$, $r_1 > 1$. The corresponding diagram is shown in figure 10 with the following dimensions and charges,

$$\begin{aligned}
h_k^{2l-1} &= h + kn_0 + (k-l-2)[(l-1)r_1 + 1], \quad k \geq 0, \quad l \geq 1 \\
h_k^{2l} &= h + kn_0 + l[(k-l+1)r_1 + 1], \quad k \geq 0, \quad l \geq 0 \\
q_k^l &= q + k
\end{aligned} \tag{4.18}$$

- (c) $r_1 = 1$, $r_2 > 1$. In this case the embedding diagram becomes the one shown in fig. 11 where the periodicity of the pattern is again set by r_2 . The corresponding dimensions are,

$$h_k = h + kn_0, \quad h'_k = h + kn_0 + k + 1, \quad q_k = q'_k = q + k \tag{4.19}$$

- (d) $r_1 = r_2 = 1$, $\tilde{c} = 3$. Then the previous diagram collapses to the one shown in fig. 12,

$$h_l^k = h + ln_0 + k(l-k+2), \quad q_l^k = q + k, \quad k \geq 2l-2 \tag{4.20}$$

In all of the above cases the character can be computed in the same way as in the respective case where \tilde{c} was irrational. Consequently the character is given by (4.12).

The only case left to consider for the NS_2 representations is $\tilde{c} = 1$ which is not included in (B).

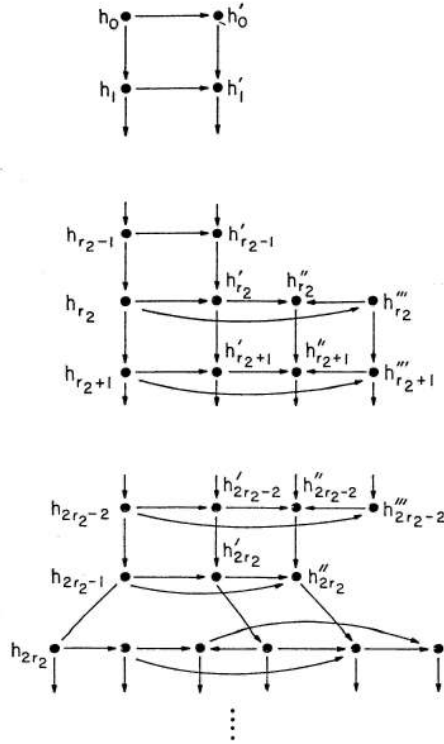

Figure 9: *Embedding diagram for NS_2 degenerate reps, $\tilde{c} = 1 + 2\frac{r_2}{r_1}$, $r_1 > 1$, $r_2 > 1$, $q = (n_0 + \frac{1}{2})(\tilde{c} - 1) + 1$*

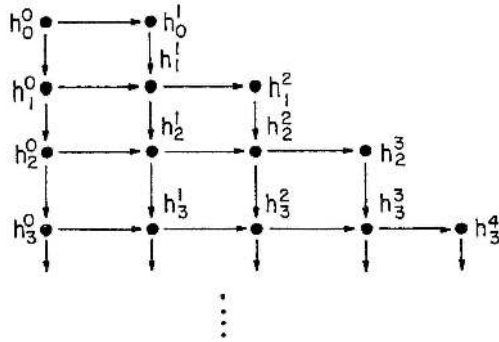

Figure 10: *Embedding diagram for NS_2 degenerate reps, $\tilde{c} = 1 + 2\frac{r_2}{r_1}$, $r_2 = 1$, $r_1 > 1$, $q = (n_0 + \frac{1}{2})(\tilde{c} - 1) + 1$*

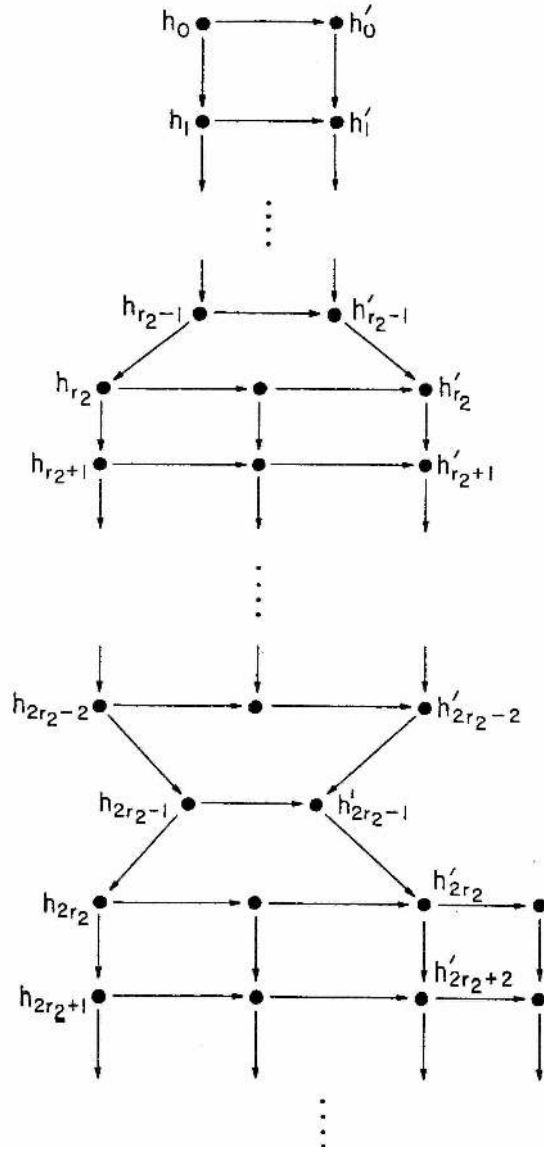

Figure 11: *Embedding diagram for NS_2 degenerate reps, $\tilde{c} = 1 + 2\frac{r_2}{r_1}$, $r_1 = 1$, $r_2 > 1$, $q = (n_0 + \frac{1}{2})(\tilde{c} - 1) + 1$*

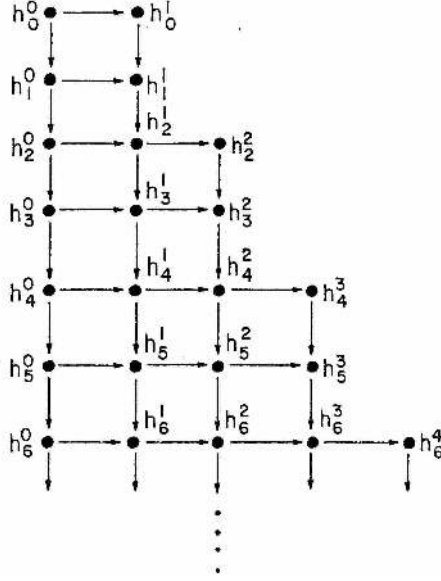

Figure 12: *Embedding diagram for NS_2 degenerate reps, $\tilde{c} = 3, q = 2n_0 + 2$*

- (C) $\tilde{c} = 1$.
- (i) $0 < q < 1$. In this case the embedding diagram becomes fairly simple and it is shown in fig. 2,

$$h_k = (q + k)n_0, \quad q_k = q + k \quad (4.21)$$

and the character is given by (4.9).

- (ii) $q = 1$. The Kač determinant simplifies enormously, its factors becoming,

$$f_{r,s}^{NS} = -q^2 + \frac{s^2}{4}, \quad g_k^{NS} = h - qk$$

This gives rise to the pattern pictured in fig. 13 with

$$h_{k,l} = k[n_0 + l - 1] \quad q_{k,l} = k, \quad k, l \geq 1 \quad (4.22)$$

The character is given again by (4.12).

We will now focus on the degenerate representations of NS_3 . They are characterized by the following conditions,

$$\tilde{c} \geq 1, \quad g_n^{NS} \geq 0 \quad \forall n \in Z + \frac{1}{2} \quad (4.23)$$

For a fixed \tilde{c} this is a convex region in the (h, q) plane bounded by pieces of the $g_n^{NS} = 0$ lines. The degenerate representations lie on the boundary of the region above and can be labeled by n_0 such that $g_{n_0}^{NS} = 0$ and their charge. This implies that their dimensions and charges are given by,

$$(\tilde{c} - 1)(n_0 - \frac{1}{2}) < q \leq (\tilde{c} - 1)(n_0 + \frac{1}{2}) \quad (4.24)$$

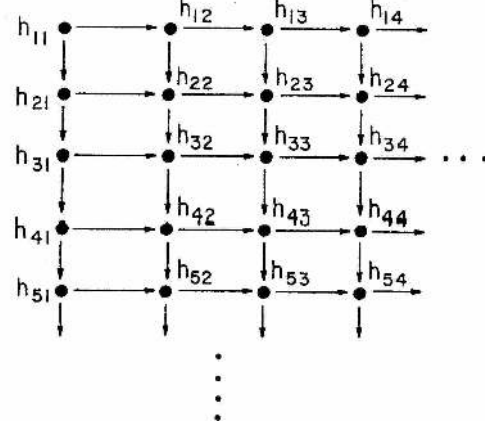

Figure 13: *Embedding diagram for NS_2 degenerate reps, $\tilde{c} = 1, q = 1$*

$$h = n_0 q - \frac{(\tilde{c} - 1)}{2} \left(n_0^2 - \frac{1}{4} \right)$$

We will focus again on $n_0 > 0$.

- (A') $\tilde{c} > 1$ *rational*.
- (i) $q = (n_0 + \frac{1}{2})(\tilde{c} - 1)$. In this case the embedding diagram is shown in fig. 15 with,

$$h_k = h + kn_0, \quad h'_k = h + k(n_0 + 1), \quad q_k = q'_k = q + k \quad (4.25)$$

For the other allowed values of q we have to distinguish the following two cases

- (ii) $q = \frac{n}{2}(\tilde{c} - 1) - m$ with $n \in \mathbb{Z}, m \in \mathbb{Z}_0^+$. The embedding diagram in this case is shown in fig.14 with,

$$h_k = h + kn_0, \quad h'_{m+k+r_2} = h + (r_2 + k)n_0 + kr_1, \quad q_k = q'_k = q + k \quad (4.26)$$

- (iii) q has any other allowed valued except the ones mentioned in (i), (ii). Then the embedding structure is the one shown in fig. 2.

- (B') $\tilde{c} > 1$ *irrational*.

- (i') $q = (n_0 + \frac{1}{2})(\tilde{c} - 1)$. Then the embedding diagram is the one shown in fig. 16 with,

$$h_k = h + kn_0, \quad h'_k = h + k(n_0 + 1), \quad q_k = q'_k = q + k \quad (4.27)$$

- (ii') For all the other allowed values of q the embedding pattern is the one of fig. 2.

The above exhaust all possible degenerate representations belonging to NS_3 . In the $\tilde{c} = 1$ case the only degenerate representation is given by the unit operator. From the structure of the representations of NS_3 we can conclude that their characters are given by (4.9).

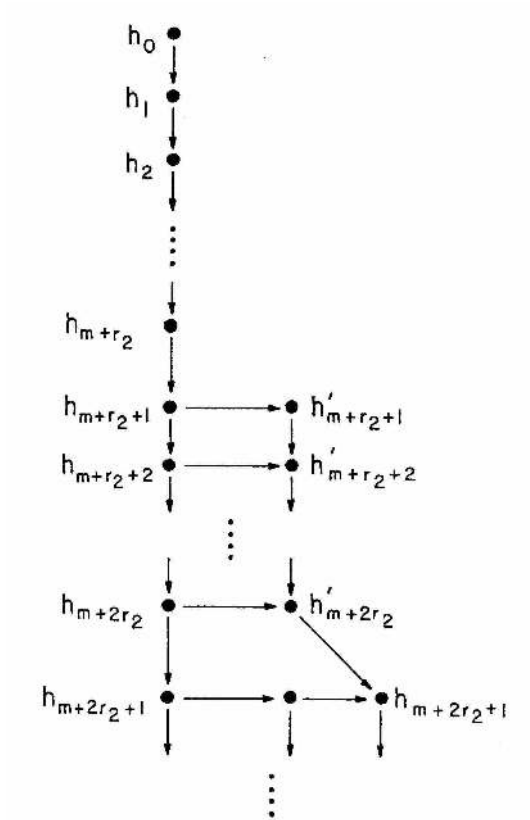

Figure 14: *Embedding diagram for NS_3 degenerate reps, $\tilde{c} = 1 + 2\frac{r_2}{r_1}$, $q = \frac{n}{2}(\tilde{c} - 1) - m$, $m, n \in \mathbb{Z}$*

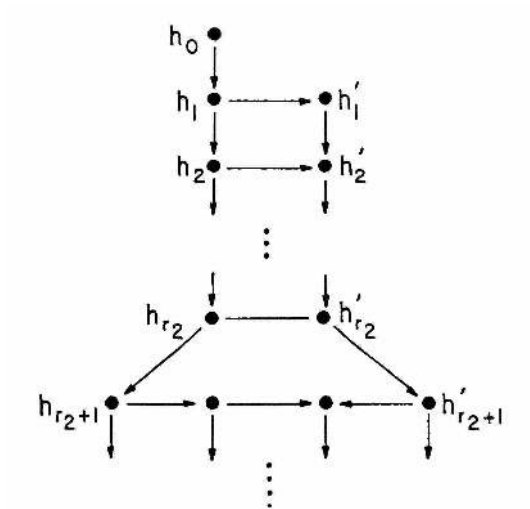

Figure 15: *Embedding diagram for NS_3 degenerate reps, $\tilde{c} = 1 + 2\frac{r_2}{r_1}$, $q = (n_0 + \frac{1}{2})(\tilde{c} - 1)$*

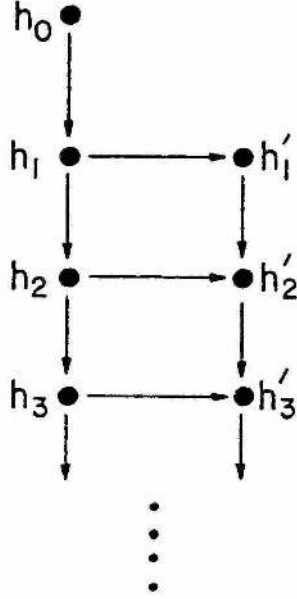

Figure 16: *Embedding diagram for NS_3 degenerate reps, $\tilde{c} > 1$, irrational, $q = (n_0 + \frac{1}{2})(\tilde{c} - 1)$*

Thus we can distinguish representations for $\tilde{c} \geq 1$ in those that have only degeneracies related to g_n with their corresponding characters given by (4.9) and in those that have additional degeneracies related to $f_{1,2}$ whose characters are given by (4.12).

The same results apply in the case $n_0 < 0$ with the following substitutions in the relevant formulae : $n_0 \rightarrow |n_0|$, $w \rightarrow w^{-1}$, $w^q \rightarrow w^q$.

The null hwt's which correspond to the representations studied above degenerate at relative charge ± 1 do not generate full Verma modules. There exist lowering operators which annihilate them.¹¹

The R^\pm algebra has analogous degenerate representations for $\tilde{c} > 1$. The structure of these representations is exactly the same as in the NS sector and the character formulae apply there as well with the obvious substitution $\bar{F}_{NS} \rightarrow \bar{F}_R$.

The special values of \tilde{c} mentioned in [1], namely $\tilde{c} = 1 + \frac{2}{n}$, $n = 1, 2, 3, \dots$ also contain the interesting case of $\tilde{c} = 3(2)$ arising in the string theory compactification on a compact six(four) dimensional Ricci flat manifold. In particular the (anti-)holomorphic ϵ -tensor realizes the representations of the NS_2 algebra, (since it is a spacetime boson), with $q = \pm\tilde{c}$ and $h = \frac{\tilde{c}}{2}$ corresponding to our notation to $r_1 = 1(2)$, $r_2 = 1$, $n_0 = \pm 1/2$, $n = \pm 3(\pm 4)$, $m = 0$. The embedding structure of their Verma module is depicted in fig. 12. The covariantly constant spinors on the internal manifold correspond to degenerate representations of the R_2^\pm , (spacetime fermions), which are degenerate at level $n_0 = 0$ with $h = \frac{\tilde{c}}{8}$ and $q = \text{sgn}(0)\frac{\tilde{c}+1}{2}$ (lying on the

¹¹For explicit examples see App. A.

intersection of $g_0^R = 0$ and $f_{1,2}^R = 0$). These representations are important in the construction of the four generators of the four-dimensional N=1 supersymmetry. The dimensions and charges of these operators should not be renormalized even non-perturbatively since the spectrum for this class of representations is discrete. Their partition functions can be read-off immediately from (4.12), and they provide the means to study questions of modular invariance in the corresponding σ -model.

5 Characters and the exact partition function of critical statistical systems

Characters are essential for the evaluation of the exact partition function of 2-d critical statistical systems, [16]. For a 2-d system defined on a flat torus, that is a parallelogram with sides l, l' , and periodic boundary conditions, at the limit $l, l' \rightarrow \infty$ with $l/l' = \delta$ fixed, the Hamiltonian operator is

$$H = \frac{2\pi}{l}(L_0 + \bar{L}_0) \quad (5.1)$$

while the momentum operator is,

$$P = \frac{2\pi}{l}(L_0 - \bar{L}_0) \quad (5.2)$$

Thus the partition function can be written as

$$Z(l, l') = e^{-fl' + \frac{\pi c R e \delta}{6}} \sum_n e^{-E_n R e l' - i P_n I m l'} \quad (5.3)$$

where we allowed l, l' to be complex twisting in that way the torus (or tilting the parallelogram). The complex parameter δ determines the conformal structure of the torus the system is defined on. Equation (5.3) can be written in a more suggestive form:

$$Z(\delta) = e^{-fA + \frac{\pi c R e \delta}{6}} Tr[z^{L_0} \bar{z}^{\bar{L}_0} \Lambda] \quad (5.4)$$

where $z = e^{-2\pi\delta}$, $\bar{z} = e^{-2\pi\delta^*}$ and Λ is a suitable projection operator in order to have a local theory.¹² Let $ch_h(z)$ be the character of the conformal family generated by a hwv of dimension h . Then,

$$Z(\delta) = e^{-fA + \frac{\pi c R e \delta}{6}} \sum_{(h, \bar{h})} N(h, \bar{h}) ch_h(\delta) ch_{\bar{h}}(\delta^*) \quad (5.5)$$

where $N(h, \bar{h})$ is the number of times the irreducible representation (h, \bar{h}) appears in the theory. The modular group is generated by the transformations, $\delta \rightarrow \delta + i$ and $\delta \rightarrow \frac{1}{\delta}$.

J. Cardy in [16] analyzed the constraints imposed by the requirement of invariance of the partition function under the modular group of the torus, on the spectrum of the theory. Invariance under the first transformation constraints the states to have integer spin, $h - \bar{h}$. Under

¹²There are two ways to obtain a local theory in the N=1 superconformal case, [15]. The choice of Λ is also crucial for questions of modular invariance of the theory.

the second transformation the characters transform non-trivially providing a representation of the modular group of the torus. For $c > 1$ the only information that can be gained¹³ is that the spectrum has to be infinite. For $c < 1$, that is the "minimal" theories, modular invariance implies a set of linear algebraic equations among the numbers $N(h, \bar{h})$. The most general solution to these equations is known for the $N=0$, $N=1$, $N=2$ minimal models, [16,17].

There exist examples of $N=1$ and $N=2$ critical systems. As it was shown in [15] the tricritical Ising model, (Ising model with vacancies), is a concrete example of a $N=1$ superconformal theory with $\hat{c} = 7/15$. Some special points in the gaussian model exhibit $N = 2$ superconformal invariance, with an anomaly $\tilde{c} = 1/3$, [4]. The $\tilde{c} = 1/3$ theory constitutes a subsector of the $\hat{c} = 2/3$ $N=1$ superconformal theory.¹⁴ It is the only member of the $\tilde{c} < 1$ $N=2$ series which has the same anomaly with a member of the $\hat{c} < 1$ $N=1$ series. For example the $N=2$ unit operator, $(0)_2$, decomposes into the unit operator of the $N=1$ theory, $(0)_1$, (containing the unit operator and one of the $N=2$ supercharges), and a dimension-one operator, $(1)_1$, (containing the $U(1)$ current of dimension one and the second $N=2$ supercharge). The representation of the NS sector with $h = \frac{1}{6}$, $q = \pm\frac{1}{3}$ decomposes into $(\frac{1}{6})_1$ of the $N=1$ NS sector. The operator $(\frac{3}{8})_2$ belonging to the Ramond sector, decomposes as $(\frac{3}{8})_2 \rightarrow (\frac{3}{8})_1$ whereas the two $(\frac{1}{24})_2$ representations of the R^\pm sector decompose as $(\frac{1}{24})_2 \rightarrow (\frac{1}{24})_1$ in the R sector of the $N=1$ theory. Finally in the twisted sector of the $\tilde{c} = 1/3$, $N=2$ system the representation of dimension $h = \frac{1}{16}$ decomposes into $(\frac{1}{16})_1$ in the NS sector of the $N=1$ system. These decompositions can be easily justified by checking the validity of the equalities between the appropriate characters:

$$ch_1^{NS}(h = 0, z) + ch_1^{NS}(h = 1, z) = ch_2^{NS}(h = 0, q = 0, z, w = 1) \quad (5.6a)$$

$$ch_1^{NS}(h = \frac{1}{6}, z) = ch_2^{NS}(h = \frac{1}{6}, q = \pm\frac{1}{3}, z, w = 1) \quad (5.6b)$$

$$ch_1^R(h = \frac{3}{8}, z) = ch_2^R(h = \frac{3}{8}, q = 0, z, w = 1) \quad (5.6c)$$

$$ch_1^R(h = \frac{1}{24}, z) = ch_2^R(h = \frac{1}{24}, q = \pm\frac{1}{3}, z, w = 1) = ch_2^R(h = \frac{1}{24}, q = \pm\frac{2}{3}, z, w = 1) \quad (5.6d)$$

$$ch_1^{NS}(h = \frac{1}{16}, z) = ch_2^T(h = \frac{1}{16}, z) \quad (5.6e)$$

It is worth pursuing the search for such systems since they seem to have a very rich and interesting structure.

6 Conclusions and prospects

In this paper we analyzed the structure of the unitary irreducible degenerate representations of the $N=1$ and $N=2$ superconformal algebras. We derived the characters of all the degenerate

¹³Using the Virasoro characters only.

¹⁴The full $\hat{c} = 2/3$ $N=1$ superconformal system has been constructed and shown to describe a particular critical point of the X-Y model, [18].

representations including the new class of degenerate representations of the N=2 algebras with $\tilde{c} \geq 1$ and we explored their connection to the exact partition functions of 2-d critical statistical systems. The characters are essential in the analysis of modular invariance of these systems and they imply constraints in the representation content of the relevant theories.

There are a lot of remaining problems to be addressed. An explicit unitary construction of the degenerate representations of the N=2 algebras with $\tilde{c} \geq 1$ is still lacking. Consequences for string compactification, spacetime supersymmetry and modular invariance must be elaborated. Some realistic and calculable superstring model-building seems feasible.

I would like to thank J. Preskill for constant encouragement and M. Douglas for several illuminating discussions. I would like also to thank D. Kastor and A. Kent for informing me that they were doing some related work and for pointing out some errors in the previous version of this paper.

7 Note Added

The evaluation of characters of the N=2 superconformal algebras has been done independently in [19] and [20] (for the discrete series).

Appendix A

In this appendix we give explicit examples of null hwv's of the N=2 algebras which, we think, are helpful to visualize several properties that we stated in the main body of the paper. Their explicit form is also very useful in deriving superdifferential equations for the correlation functions of the degenerate primary fields. We remind the reader that a null hwv is a secondary state, $|\chi\rangle$, in a Verma module which has also the properties of a hwv, namely,

$$L_n|\chi\rangle = J_n|\chi\rangle = G_r|\chi\rangle = \bar{G}_r|\chi\rangle = 0, \quad n, r > 0 \quad (A.1)$$

It is easy to deduce that such states have zero norm and the Verma module they generate is orthogonal to all other states contained in the initial Verma module. So they can consistently set to zero and this condition implies superdifferential equations for correlation functions of the initial hwv with other operators. These equations provide us with the means to solve the theory exactly. Such a theory must contain only degenerate representations.

- (i) *NS algebra*, relative charge zero. An example of a null vector belonging to the superconformal family generated by $|h, q\rangle$ at the first level and relative charge zero is given by:

$$|\chi\rangle = [(q-1)L_{-1} - (2h+1)J_{-1} + G_{-1/2}\bar{G}_{-1/2}]|h, q\rangle \quad (A.2)$$

when $2h(\tilde{c}-1) = q^2 - \tilde{c}$. The only non-trivial hwv condition that one has to check is the action of L_{-1} , J_{-1} , $G_{-1/2}$, $\bar{G}_{-1/2}$. The others are trivially satisfied.

- *NS algebra* relative charge ± 1 .

Let's first consider a state which is degenerate at the $n_0 = 1/2$ level. Then, $g_{1/2}^{NS} = 2h - q$ so that a state with $h = q/2$ is an example of a primary state that generates such a representation. The null state in this representation is given by,

$$|\chi_{1/2}^+\rangle = G_{1/2}|h, q\rangle \quad (A.3)$$

which is obviously annihilated by any of L_n , J_n , G_n , \bar{G}_n for $n \geq 1$. The only non-trivial condition is $\bar{G}_{1/2}|\chi_{1/2}^+\rangle = (2h - q)|\chi_{1/2}^+\rangle = 0$ due to the previously mentioned relation between his dimension and charge. It is obvious that this null vector does not generate a full Verma module since it is annihilated by $G_{-1/2}$. For $n_0 = -1/2$ the corresponding null state is $|\chi_{1/2}^-\rangle = \bar{G}_{-1/2}|h, q\rangle$. At higher levels the degenerate states involve also generators of the Virasoro or the U(1) algebra. For example at $n_0 = \pm 3/2$ the corresponding states are,

$$|\chi_{3/2}^+\rangle = [(h - \frac{q}{2} + 1)G_{-3/2} + G_{-1/2}(J_{-1} - L_{-1})]|h, q\rangle \quad (A.4a)$$

$$|\chi_{3/2}^-\rangle = [(h + \frac{q}{2} + 1)\bar{G}_{-3/2} - \bar{G}_{-1/2}(J_{-1} + L_{-1})]|h, q\rangle \quad (A.4b)$$

Again these null hwv's do not generate full Verma modules. There exist lowering operators that annihilate them.

$$[(h - \frac{q}{2} + 1)G_{-3/2} + (J_{-1} - L_{-1})G_{-1/2}]|\chi_{3/2}^+\rangle = 0 \quad (A.5a)$$

$$[(h + \frac{q}{2} + 1)\bar{G}_{-3/2} - (J_{-1} + L_{-1})\bar{G}_{-1/2}]|\chi_{3/2}^- \rangle = 0 \quad (\text{A.5b})$$

Finally at level 5/2 and relative charge one, when $2h - 5q + 6(\tilde{c} - 1) = 0$, the null hwv is,

$$|\chi_{5/2}^+ \rangle = [(2h - q + 4)(q + 3 - 2\tilde{c})G_{-5/2} + (2h - q + 4)G_{-3/2}\hat{\Lambda}_{-1} + G_{-1/2}\hat{\Lambda}_{-2}]|h, q \rangle$$

$$\hat{\Lambda}_{-1} = (2J_{-1} - L_{-1}) \quad (\text{A.6})$$

$$\hat{\Lambda}_{-2} = [(q + 3 - 2\tilde{c})(3J_{-2} - 2L_{-2}) - 4J_{-2} + 2(L_{-1})^2 + 4(J_{-1})^2 - 6J_{-1}L_{-1} + G_{-3/2}\bar{G}_{-1/2}]$$

- (ii) R^\pm algebra, null states with the same charge as the initial hwv.

An example of a null hwv of the representation of the R^\pm algebra generated by $|h, q \pm 1/2 \rangle_\pm$ at the first level is given by :

$$|\chi_+ \rangle = [(q + 1)(2h - \frac{\tilde{c}}{4})L_{-1} - (2h + \frac{3}{4})(2h - \frac{\tilde{c}}{4})J_{-1} - (2h - \frac{q}{2} + \frac{1}{4})\bar{G}_{-1}G_0]|h, q - 1/2 \rangle_+$$

$$(\text{A.7a})$$

$$|\chi_- \rangle = [(q - 1)(2h - \frac{\tilde{c}}{4})L_{-1} - (2h + \frac{3}{4})(2h - \frac{\tilde{c}}{4})J_{-1} + (2h + \frac{q}{2} + \frac{1}{4})G_{-1}\bar{G}_0]|h, q + 1/2 \rangle_-$$

$$(\text{A.7b})$$

satisfying all the hwv conditions provided $h = \frac{\tilde{c}}{8} + \frac{q^2 - (\tilde{c} + 1)^2/4}{2(\tilde{c} - 1)}$.

- R^\pm algebra, null states having charges differing by ± 1 from the initial charge.

In the R^+ algebra the null state at $n_0 = 0$ and relative charge $+1/2$ is,

$$|\chi_0^+ \rangle = G_0|h, q - 1/2 \rangle_+ \quad (\text{A.8})$$

which is annihilated by G_0 provided $h = \frac{\tilde{c}}{8}$. At level one and relative charge $+1/2$ and $-3/2$, ($n_0 = \pm 1$), the null states are :

$$|\chi_1^+ \rangle = [(2h + 2 - \frac{\tilde{c}}{4})G_{-1} + G_0(J_{-1} - 2L_{-1})]|h, q - 1/2 \rangle_+ \quad (\text{A.9a})$$

$$|\chi_1^- \rangle = \bar{G}_{-1}|h, q - 1/2 \rangle_+ \quad (\text{A.9b})$$

The state $|\chi_1^+ \rangle$ is annihilated by the operator $(2h + 2 - \frac{\tilde{c}}{4})G_{-1} + (J_{-1} - 2L_{-1})G_0$, whereas $|\chi_1^- \rangle$ is annihilated by \bar{G}_{-1} . At level two and relative charge $+1/2$, ($n_0 = 2$), the null state is,

$$|\chi_2^+ \rangle = [2(q - \tilde{c} + 2)(2q - 3\tilde{c} + 5)G_{-2} + 2(q - \tilde{c} + 2)G_{-1}\bar{\Lambda}_{-1} + G_0\bar{\Lambda}_{-2}]|h, q - 1/2 \rangle_+$$

$$\bar{\Lambda}_{-1} = (3J_{-1} - 2L_{-1}) \quad (\text{A.10})$$

$$\bar{\Lambda}_{-2} = [(2q - 3\tilde{c} + 5)(J_{-2} - L_{-2}) - 3J_{-2} + 2(L_{-1})^2 + \frac{3}{2}(J_{-1})^2 - 4J_{-1}L_{-1} + G_{-1}\bar{G}_{-1}]$$

At $n_0 = -2$ the null hwv of relative charge $-3/2$ is,

$$|\chi_2^- \rangle = [(2q + 3\tilde{c} - 5)\bar{G}_{-2} + \bar{G}_{-1}(2L_{-1} + 3J_{-1})]|h, q - 1/2 \rangle_+ \quad (\text{A.11})$$

The corresponding null state of the R^- algebra at level zero is,

$$|\chi_0^- \rangle = \bar{G}_0|h, q + 1/2 \rangle_- \quad (\text{A.12})$$

annihilated by \bar{G}_0 , whereas at level one, ($n_0 = \pm 1$), they are,

$$|\chi_1^+ \rangle = [(2h + 2 - \frac{\tilde{c}}{4})\bar{G}_{-1} - \bar{G}_0(2L_{-1} + J_{-1})]|h, q + 1/2 \rangle_- \quad (\text{A.13a})$$

$$|\chi_1^- \rangle = G_{-1}|h, q + 1/2 \rangle_- \quad (\text{A.13b})$$

annihilated by $[(2h + 2 - \frac{\tilde{c}}{4})\bar{G}_{-1} - (2L_{-1} + J_{-1})\bar{G}_0]$ and G_{-1} respectively.

- (iii) *T algebra*. When $h = \frac{\tilde{c}}{8}$, one of the two states of opposite parity is degenerate at level zero and decouples from the spectrum. The explicit form of the null hwv is,

$$|\chi_0^- \rangle = G_0^1|h \rangle \quad (\text{A.14})$$

which has negative parity. (We define the parity or fermion number operator, $(-1)^F$, so that it commutes with L_{-n} , J_{-n} and anticommutes with G_{-n}^1 , G_{-n}^2 . It is obvious that it counts the number of fermionic operators modulo two.) The existence of the state with $h = \frac{\tilde{c}}{8}$ implies the non-vanishing of the Witten index and thus that supersymmetry is unbroken on the cylinder.

At level $1/2$ there are two null hwv's of opposite parity when $h\tilde{c} = h - \frac{\tilde{c}}{8}$,

$$|\chi_{1/2}^- \rangle = [2iJ_{-1/2}G_0^1 + \tilde{c}G_{-1/2}^2]|h \rangle \quad (\text{A.15a})$$

$$|\chi_{1/2}^+ \rangle = [2ihJ_{-1/2} + G_{-1/2}^2G_0^1]|h \rangle \quad (\text{A.15b})$$

At level one there are again two null hwv's provided $2h = -\frac{3\tilde{c}^2 - 3\tilde{c} + 1}{4(\tilde{c} - 1)}$,

$$|\chi_1^+ \rangle = [(2\tilde{c} - 1)(2(\tilde{c} - 1)L_{-1} + (J_{-1/2})^2) + (\tilde{c} - 1)(8iJ_{-1/2}G_{-1/2}^2G_0^1 - 4\tilde{c}G_{-1}^1G_0^1)]|h \rangle \quad (\text{A.16a})$$

$$|\chi_1^- \rangle = [4(\tilde{c} - 1)L_{-1}G_0^1 - 2i(2\tilde{c} - 1)J_{-1/2}G_{-1/2}^2 + 2(J_{-1/2})^2G_0^1 + \tilde{c}(2\tilde{c} - 1)G_{-1}^1]|h \rangle \quad (\text{A.16b})$$

The examples presented above are also very important in the derivation of the super-differential equations satisfied by the correlation functions of the corresponding degenerate hwv's.

Appendix B

In this appendix we will evaluate the partition functions for the N=2 superconformal algebras.

For the NS and R^\pm algebras the partition functions are defined as:

$$F(z, w) = z^{-h} w^{-q} \text{Tr}[z^{L_0} w^{J_0}] \quad (B.1)$$

whereas for the T-algebra :

$$F(z) = z^{-h} \text{Tr}[z^{L_0}] \quad (B.2)$$

where the trace is taken over all the secondary states of a non-degenerate representation of dimension h and charge q .

- (i) NS algebra. A basis of states is given by,

$$|(n), (m), (k), (r)\rangle = L(n)J(m)G(k)\bar{G}(r)|h, q\rangle \quad (B.3)$$

where the respective operators are defined as,

$$L(n) \equiv (L_{-1})^{n_1} (L_{-2})^{n_2} \dots \quad n_i \in N_0 \quad (B.4a)$$

$$J(m) \equiv (J_{-1})^{m_1} (J_{-2})^{m_2} \dots \quad m_i \in N_0 \quad (B.4b)$$

$$G(k) \equiv (G_{-1/2})^{k_1} (G_{-3/2})^{k_2} \dots \quad k_i \in (0, 1) \quad (B.4c)$$

$$\bar{G}(r) \equiv (\bar{G}_{-1/2})^{r_1} (\bar{G}_{-3/2})^{r_2} \dots \quad r_i \in (0, 1) \quad (B.4d)$$

$$G_r \equiv \frac{1}{\sqrt{2}}(G_r^1 + iG_r^2), \quad \bar{G}_r \equiv \frac{1}{\sqrt{2}}(G_r^1 - iG_r^2)$$

Any other permutation in (B.4) can be expressed, using the commutation relations of the algebra, as a linear combination of the above. The range of the exponents in (B.4c,d) is such because the squares of G_r and \bar{G}_r are zero due to the anti-commutation relations.

The next step is to evaluate the expectation value,

$$F[(n), (m), (k), (r)] \equiv \langle (n), (m), (k), (r) | z^{L_0} w^{J_0} | (n), (m), (k), (r) \rangle \quad (B.5)$$

where the basis states are assumed to be normalized. J_0 commutes with L_{-n} , J_{-n} for every $n \in Z$ and

$$[J_0, G_{-r}] = G_{-r}, \quad [J_0, \bar{G}_{-r}] = -\bar{G}_{-r}$$

To evaluate the commutators of w^{J_0} with the supercharge operators we have to consider:

$$f(\delta) \equiv e^{\delta J_0} (G_{-r})^k e^{-\delta J_0}$$

$$\frac{df}{d\delta} = r f(\delta) \quad (B.6)$$

Solving the differential equation and setting $w = e^\delta$, we obtain:

$$w^{J_0}(G_{-r})^k = (G_{-r})^k w^{J_0+k} \quad , \quad k \in (0, 1) \quad (B.7a)$$

$$w^{J_0}(\bar{G}_{-r})^k = (\bar{G}_{-r})^k w^{J_0-k} \quad , \quad k \in (0, 1) \quad (B.7b)$$

The same procedure for the z^{L_0} factor gives

$$z^{L_0}(L_{-n})^k = (L_{-n})^k z^{L_0+nk} \quad , \quad z^{L_0}(J_{-n})^k = (J_{-n})^k z^{L_0+nk} \quad (B.8a)$$

$$z^{L_0}(G_{-n})^k = (G_{-n})^k z^{L_0+nk} \quad , \quad z^{L_0}(\bar{G}_{-n})^k = (\bar{G}_{-n})^k z^{L_0+nk} \quad (B.8b)$$

Taking into account all the above we obtain :

$$F[(n), (m), (k), (r)] = z^h w^q \left[z^{\sum_{j=1}^{\infty} (jn_j + jm_j)} (z^{\frac{1}{2}} w)^{k_1} (z^{\frac{3}{2}} w)^{k_2} \dots \left(\frac{z^{\frac{1}{2}}}{w}\right)^{r_1} \left(\frac{z^{\frac{3}{2}}}{w}\right)^{r_2} \dots \right] \quad (B.9)$$

It remains to sum over all the permissible sets of integers $(n), (m), (k), (r)$.

$$\sum_{(n_i)} z^{\sum_{j=1}^{\infty} j n_j} = \sum (n_i) \prod_{j=1}^{\infty} z^{j n_j} = \prod_{j=1}^{\infty} \sum_{(n_i)} z^{j n_j} = \prod_{j=1}^{\infty} \frac{1}{(1 - z^j)} \quad (B.10a)$$

$$\sum_{k_i=0,1} (z^{\frac{2i-1}{2}} w)^{k_i} = (1 + z^{\frac{2i-1}{2}} w) \quad (B.10b)$$

so that finally,

$$\bar{F}_{NS}(z, w) = \prod_{n=1}^{\infty} \frac{(1 + z^{n-1/2} w)(1 + z^{n-1/2} w^{-1})}{(1 - z^n)^2} \quad (B.11)$$

For the R^+ algebra the modding of the supercharges is integral. The derivation goes along the same lines with the following minor modifications. There is the additional contribution of G_0 , (\bar{G}_0 annihilates the primary state $|h, q - 1/2 \rangle_+$), which amounts to a factor $(1 + w)$, there is another factor of $w^{-1/2}$ coming from the incomplete cancellation of $w^{q-1/2}$ and since we have integer modding, $n - 1/2$ in (B.11) is replaced by n . Consequently the partition function for the R^+ algebra is,

$$\bar{F}_R(z, w) = (w^{1/2} + w^{-1/2}) \prod_{n=1}^{\infty} \frac{(1 + z^n w)(1 + z^n w^{-1})}{(1 - z^n)^2} \quad (B.12)$$

In the R^- algebra we have to replace G_0 with \bar{G}_0 and $q - 1/2$ with $q + 1/2$. The partition function is identical to (B.12).

We have also to discuss the partition functions of single charged fermions. Some particular examples in this case are the incomplete Verma modules generated by the null vectors of the degenerate representations of the NS and R^\pm algebras with $\tilde{c} \geq 1$. To motivate the discussion, let's look at the simplest example of such a module generated by the null

hwv at level $1/2$, ($n_0 = 1/2$), of the NS algebra, given explicitly by (A.3). This state, as it was mentioned before is annihilated by $G_{-1/2}$. So, in our previous computation of the partition functions, basis states with a $G_{-1/2}$ operator in them do not contribute. This in turn means that a factor $(1 + z^{1/2}w)$ is absent from the corresponding partition function. The first non-trivial example comes at level $3/2$, ($n_0 = 3/2$), the null hwv given explicitly by (A.4a). Instead of choosing the $G_{-3/2}$, $G_{-1/2}J_{-1}$, $G_{-1/2}L_{-1}$ as basis operators, we can choose the annihilating operator, $(2h - q/2 + 1)G_{-3/2} + (J_{-1} - L_{-1})G_{-1/2}$, giving a zero contribution, and the remaining $G_{-1/2}J_{-1}$, $G_{-1/2}L_{-1}$. Thus, effectively, the contribution of $G_{-3/2}$ is absent, causing a loss of a factor $(1 + z^{3/2}w)$ from the corresponding partition function. For the null hwv at $n_0 = -3/2$, given by (A.4b), following the previous argument, the contribution of $\bar{G}_{-3/2}$ is again effectively missing, and consequently a factor $(1 + z^{3/2}w^{-1})$ is absent from the partition function.

Now the general situation is evident. For a null hwv at some level $|n_0|$, (n_0 being an integer or half-integer, corresponding to R^\pm or NS respectively), the partition function lacks the contribution of G_{-n_0} , $sgn(n_0) > 0$ or \bar{G}_{-n_0} , $sgn(n_0) < 0$. Thus the partition function is given by :

$$\tilde{F}_X(z, w; n_0) = [1 + z^{|n_0|}w^{sgn(n_0)}]^{-1} \bar{F}_X(z, w) \quad (B.13)$$

where X stands for either R or NS .

In the T-algebra the situation is now clear. There is no w^{J_0} factor. The contribution from the Virasoro and U(1) operators is $\prod_{n=1}^{\infty} (1 - z^n)^{-1} (1 - z^{n-1/2})^{-1}$ (the U(1) generators have half-integer modding). The contribution from the G_{-r}^1 operators, (integer modding), is $\prod_{n=1}^{\infty} (1 + z^n)$, whereas for the G_{-r}^2 operators, (half-integer modding), it is $\prod_{n=1}^{\infty} (1 + z^{n-1/2})$. Collecting everything :

$$\bar{F}_T(z, w) = \prod_{n=1}^{\infty} \frac{(1 + z^n)(1 + z^{n-1/2})}{(1 - z^n)(1 - z^{n-1/2})} \quad (B.14)$$

This concludes the derivation of the partition functions of the N=2 superconformal algebras.

References

- [1] W. Boucher, D. Friedan, A. Kent, Phys. Lett. **172B** (1986) 316.
- [2] P. DiVecchia, J. L. Petersen, H. B. Zheng, Phys. Lett. **162B** (1986) 327; P. DiVecchia, J. L. Petersen, M. Yu, Phys. Lett. **172B** (1986) 211; P. DiVecchia, J. L. Petersen, M. Yu, H. B. Zheng, Phys. Lett. **174B** (1986) 280.
- [3] S. Nam, Phys. Lett. **172B** (1986) 323.
- [4] G. Waterson, Phys. Lett. **171B** (1986) 77.
- [5] M. Ademolo et al. Phys. Lett. **62B** (1976) 105, Nucl. Phys. **B111** (1976) 77.
- [6] P. Candelas, G Horowitz, A. Strominger, E. Witten, Nucl. Phys. **B258** (1985) 46; C.Hull, E. Witten, M.I.T. preprint (1985).
- [7] D. Friedan, S. Shenker, EFI preprint, EFI-86-17 (unpublished).
- [8] D. Friedan, E. Martinec, S. Shenker, Nucl. Phys. **B271** (1986) 93.
- [9] B. L. Feigin, D. B. Fuks, Funct. Anal. Prilozhen. **17** No 3 (1983) 91.
- [10] A. Rocha-Caridi in "Vertex Operators in Mathematics and Physics" Ed. J. Lepowsky (Springer Verlag, New York, 1984).
- [11] P. Goddard, A. Kent, D. Olive, Comm. Math. Phys. **103** (1986) 105.
- [12] D. Friedan, Z. Qiu, S. Shenker in "Vertex Operators in Mathematics and Physics" Ed. J. Lepowsky (Springer Verlag, New York, 1984).
- [13] A. Meurman, A. Rocha-Caridi, Comm. Math. Phys. **107** (1986) 263.
- [14] C. Thorn, unpublished and Nucl. Phys. **B248** (1984) 551.
- [15] D. Friedan, Z. Qiu, S. Shenker, Phys. Lett. **151B** (1985) 37.
- [16] J. L. Cardy, Nucl. Phys. **B270** (1986) 186.
- [17] D. Kastor, Nucl. Phys. **B280** (1987) 304;
Y. Matsuo, S. Yahikozawa, V. T. preprint, UT-485;
C. Itzykson, J. B. Zuber, Nucl. Phys. **B280** [FS18] (1987) 445;
D. Gepner, Nucl. Phys. **B287** (1987) 111;
F. Ravanini, S. K. Yang, Phys. Lett. **195B** (1987) 202;
Z. Qiu, Phys. Lett. **198B** (1987) 497.
- [18] E. Kiritsis, J. of Phys. A (in press);
S. K. Yang, Nucl. Phys. **B285** (1987) 183.
- [19] V. K. Dobrev, Phys. Lett. **B186** (1987) 43.
- [20] V. Matsuo, Progr. Theor. Phys. **77** (1987) 7930.