

 Open access • Report • DOI:10.2172/1013934

## **Characterization of Fish Passage Conditions through a Francis Turbine, Spillway, and Regulating Outlet at Detroit Dam, Oregon, Using Sensor Fish, 2009** — [Source link](#)

Joanne P. Duncan, Thomas J. Carlson

**Published on:** 06 May 2011

**Topics:** Spillway

Related papers:

- [Characterization of Fish Passage Conditions through a Francis Turbine and Regulating Outlet at Cougar Dam, Oregon, Using Sensor Fish, 2009–2010](#)
- [Evaluation of Fish Passage Conditions for Juvenile Salmonids Using Sensor Fish at Detroit Dam, Oregon](#)
- [Hydroacoustic Evaluation of Juvenile Salmonid Passage and Distribution at Detroit Dam, 2011](#)
- [Characterization of Fish Passage Conditions through the Fish Weir and Turbine Unit 1 at Foster Dam, Oregon, Using Sensor Fish, 2012](#)
- [Hydroacoustic Evaluation of Fish Passage Through Bonneville Dam in 2002](#)

Share this paper:    

View more about this paper here: <https://typeset.io/papers/characterization-of-fish-passage-conditions-through-a-2lqnmzq6za>



**US Army Corps  
of Engineers®**

Prepared for the U.S. Army Corps of Engineers, Portland District,  
under an Interagency Agreement with the U.S. Department of Energy  
Contract DE-AC05-76RL01830

PNNL-20365

# Characterization of Fish Passage Conditions through a Francis Turbine, Spillway, and Regulating Outlet at Detroit Dam, Oregon, Using Sensor Fish, 2009

## Final Report

JP Duncan  
TJ Carlson

May 2011



**Pacific Northwest**  
NATIONAL LABORATORY

*Proudly Operated by **Battelle** Since 1965*

## DISCLAIMER

This report was prepared as an account of work sponsored by an agency of the United States Government. Neither the United States Government nor any agency thereof, nor Battelle Memorial Institute, nor any of their employees, makes **any warranty, express or implied, or assumes any legal liability or responsibility for the accuracy, completeness, or usefulness of any information, apparatus, product, or process disclosed, or represents that its use would not infringe privately owned rights.** Reference herein to any specific commercial product, process, or service by trade name, trademark, manufacturer, or otherwise does not necessarily constitute or imply its endorsement, recommendation, or favoring by the United States Government or any agency thereof, or Battelle Memorial Institute. The views and opinions of authors expressed herein do not necessarily state or reflect those of the United States Government or any agency thereof.

PACIFIC NORTHWEST NATIONAL LABORATORY

*operated by*

BATTELLE

*for the*

UNITED STATES DEPARTMENT OF ENERGY

*under Contract DE-AC05-76RL01830*

Printed in the United States of America

Available to DOE and DOE contractors from the  
Office of Scientific and Technical Information,  
P.O. Box 62, Oak Ridge, TN 37831-0062;  
ph: (865) 576-8401  
fax: (865) 576-5728  
email: reports@adonis.osti.gov

Available to the public from the National Technical Information Service,  
U.S. Department of Commerce, 5285 Port Royal Rd., Springfield, VA 22161  
ph: (800) 553-6847  
fax: (703) 605-6900  
email: orders@ntis.fedworld.gov  
online ordering: <http://www.ntis.gov/ordering.htm>



This document was printed on recycled paper.

(9/2003)

# **Characterization of Fish Passage Conditions through a Francis Turbine, Spillway, and Regulating Outlet at Detroit Dam, Oregon, Using Sensor Fish, 2009**

## **Final Report**

JP Duncan  
TJ Carlson

May 2011

Prepared for  
the U.S. Army Corps of Engineers, Portland District,  
under an Interagency Agreement with  
the U.S. Department of Energy  
Contract DE-AC05-76RL01830

Pacific Northwest National Laboratory  
Richland, Washington 99352

## Summary

Fish passage conditions through two spillways, a Francis turbine, and a regulating outlet (RO) at Detroit Dam on the North Santiam River in Oregon were evaluated by Pacific Northwest National Laboratory for the U.S. Army Corps of Engineers (USACE), Portland District, using Sensor Fish devices. The objective of the study was to describe and compare passage exposure conditions, identifying potential fish injury regions within the routes. The study was performed in July, October, and December 2009 concurrent with HI-Z balloon-tag studies by Normandeau Associates, Inc.

Sensor Fish data were analyzed to estimate 1) exposure conditions, particularly exposure to severe strike, collision, and shear events by passage route sub-regions; 2) differences in passage conditions between passage routes; and 3) relationships to live-fish injury and mortality data estimates.

For the spillway evaluation, Sensor Fish and live fish were deployed at elevations (1544 ft above mean sea level [MSL] and 1542.5 ft MSL for the 3.5-ft and 1.5-ft gate opening, respectively) approximately 3 ft above spillway entrance structure at depths determined using a computational fluid dynamics model. Release depth and position were established to introduce the fish and sensors into flow of approximately 5 feet per second (fps). The 1.5-ft and 3.5-ft spillgate openings correspond to approximate discharge flows of 1560 and 3090 cubic feet per second (cfs), respectively. All but one Sensor Fish experienced a significant event, as determined from acceleration magnitude data (<1%;  $n = 109$ ). Event severity was greatest for Sensor Fish passing through Spillbay 3 at the 3.5-ft gate opening, with a mean impulse peak value of 175.03  $g$  ( $n = 7$ ) for the most severe event per release and 131.34  $g$  for Sensor Fish experiencing more than one event (multiple events) per release for that condition. The majority of Sensor Fish significant events were classified as collisions; the most severe occurred on the spillway chute. Shear events were less frequent, occurring at all sub-regions of the passage route. Frequency of occurrence of shear events during passage was greatest during for the 3.5-ft gate opening test condition. Flow quality, computed using the Sensor Fish turbulence index, was best for passage through Spillbay 3 at the 1.5-ft gate opening. The worst flow quality was observed for the 3.5-ft gate opening test condition.

The depth of flow on the spillway chute, which was greater at higher discharge, was likely a determining factor in the frequency of occurrence, location, and severity of collision events. The higher frequency of occurrence of collisions on the spillway chute during the 1.5-ft tainter gate opening test compared to that observed during the 3.5-ft gate opening supports this assumption. However, the elevation at which the Sensor Fish were injected into spillway flow was most likely also an important factor.

For the turbine evaluation, Sensor Fish were injected into turbine intake flow about 1.5 ft below the penstock ceiling into water velocities of approximately 12.5 fps. Turbine discharge was approximately 2200 cfs during the study period. All Sensor Fish experienced more than one significant strike, collision, or shear event during passage through the wicket gate and turbine runner. The average value for these events was 176.5  $g$  ( $n = 19$ ), the highest values observed to date, with maximum values as high as 234  $g$ . Of the primary events observed, 58% were due to shear and 42% were strike or collision. An average of 5.0 events occurred during turbine passage per Sensor Fish release, and 13% of the Sensor Fish released were physically damaged during passage. Of all events observed, 98% occurred in the wicket gate–runner region; one event was observed prior to the runner and one in the draft tube region. Mean pressure nadir values obtained during turbine runner passage at Detroit Dam were the lowest observed to date

using Sensor Fish, less than one-half that observed at dams on the Columbia and Snake rivers. Related pressure rate-of-change was more than 2 times greater than that observed for turbine passage at mainstem Columbia River projects.

Passage through the regulating outlet (RO) was evaluated at two test conditions—gate openings of 1 ft and 5 ft, with corresponding approximate discharges of 460 cfs and 1800 cfs, respectively. The injection system pipe terminus was positioned at approximately elevation 1343 ft MSL, 3 ft above the RO centerline elevation and 2 ft below the passageway ceiling. Computational fluid dynamics modeling determined flow velocities at the injection pipe exit to be approximately 4 and 18 fps for the 1-ft and 5-ft openings, respectively. More than 94% of the Sensor Fish experienced at least one significant collision event during RO passage ( $n = 36$ ); over 72% of the Sensor Fish experienced multiple collision events. The mean acceleration magnitudes for the most severe events observed for the 1-ft and 5-ft openings were 141.6  $g$  ( $n = 17$ ) and 144.2  $g$  ( $n = 19$ ), respectively.

Regulating outlet passage conditions for the 1-ft gate opening were found to be detrimental to live fish. The rapid acceleration in flow during passage under the flow control gate created conditions that were responsible for decapitation of 9.3 % of test fish. In contrast, none of the live fish passing through the 5-ft gate opening were decapitated. Flow acceleration magnitudes during the 1-ft gate open test condition were nearly 4 times greater than those observed during the 5-ft gate opening test condition. Rapid changes in pressure were also observed as flow passed under the control gate, with pressure rates of change 3.5 times greater for the 1-ft gate opening than for the 5-ft gate opening.

Results from the Sensor Fish passage evaluations at Detroit Dam would likely differ under other dam operations. Live fish used during the studies were not depth-acclimated. Research has shown that juvenile salmon that are not acclimated to depth as they are in nature do not show the same response to rapid decompression as do fish that are acclimated. The rates of change in pressure as well as pressure nadir magnitudes indicate that the injury and mortality rates observed for passage of fish through Detroit turbines are most likely underestimated. The same is probably true for injury and mortality rate estimates for the RO and perhaps spillway passage as well. It is likely that other passage conditions under which rates of change in pressure and nadir magnitudes would be greater and lower, respectively, would lead to increases in injury and mortality rates. Observed injury and mortality rates are not absolute estimates of biological response to passage of juvenile salmon through Detroit Dam turbines, the RO, or spillways but do have utility as estimates of the response of passing fish to mechanical sources of injury.

Comparison of the three passage routes evaluated at Detroit Dam indicates that the RO passage route through the 5-ft gate opening was relatively the safest route for fish passage under the operating conditions tested; turbine passage was the most deleterious. These observations were supported also by the survival and malady estimates obtained from live-fish testing. Injury rates were highest for turbine and spillway passage. However, none of the passage routes tested is safe for juvenile salmonid passage.

## Acronyms and Abbreviations

CFD	computational fluid dynamics
cfs	cubic feet per second
CI	confidence interval
fps	feet per second
ft	foot, feet
<i>g</i>	average acceleration produced by gravity at the Earth's surface (sea level); used in this report as a measure of event magnitude
hr	hour(s)
Hz	hertz
in.	inch(es)
min	minute(s)
mm	millimeter(s)
MSL	mean sea level
MW	megawatt(s)
<i>n</i>	sample size
PNNL	Pacific Northwest National Laboratory
psia	pounds per square inch absolute
RO	regulating outlet
s	second(s)
USACE	U.S. Army Corps of Engineers

## Contents

Summary .....	iii
Acronyms and Abbreviations .....	v
1.0 Introduction .....	1.1
1.1 Objectives.....	1.1
1.2 Report Overview .....	1.2
2.0 Methods .....	2.1
2.1 Study Site .....	2.1
2.2 Sensor Fish Device.....	2.3
2.3 Procedures .....	2.3
2.3.1 Spillway Evaluation .....	2.4
2.3.2 Penstock/Turbine Assessment.....	2.4
2.3.3 Regulating Outlet Evaluation .....	2.4
2.4 Data Analysis .....	2.5
3.0 Results .....	3.1
3.1 Treatment Release Data .....	3.1
3.1.1 Spillway.....	3.1
3.1.2 Penstock/Turbine.....	3.2
3.1.3 Regulating Outlet .....	3.2
3.2 Data Analysis .....	3.3
3.2.1 Spillway Passage .....	3.3
3.2.2 Penstock/Turbine Passage.....	3.4
3.2.3 Regulating Outlet Passage.....	3.6
3.3 Strike, Collision, and Shear Events.....	3.7
3.3.1 Spillway Passage .....	3.7
3.3.2 Penstock/Turbine Passage.....	3.9
3.3.3 Regulating Outlet Passage.....	3.11
3.4 Turbulence Index.....	3.13
3.5 Comparison of Sensor Fish and Live-Fish Data .....	3.13
4.0 Discussion.....	4.1
4.1 Spillway Passage.....	4.1
4.2 Penstock/Turbine Passage.....	4.6
4.3 Regulating Outlet Passage.....	4.9
4.4 All Passage Routes .....	4.14
5.0 Conclusions .....	5.1
6.0 References .....	6.1



Appendix A – Field Log Data Sheets .....	CD
Appendix B – Data Summary Tables for Each Sensor Fish Release.....	CD
Appendix C – Pressure and Acceleration Magnitude Time Histories of Each Sensor Fish Release .....	CD
Appendix D – Pressure and Angular Rate-of-Change Time Histories of Each Sensor Fish Release .....	CD

## Figures

2.1	Detroit Dam on the North Santiam River.....	2.1
2.2	Detroit Dam, Oregon.....	2.2
2.3	Cross section of a Detroit Dam penstock.....	2.2
2.4	Six-degree-of-freedom Sensor Fish device.....	2.3
3.1	Sensor Fish data overlaid on a cross section of Detroit Dam showing the approximate locations for major timing marks during spillway passage.....	3.4
3.2	Sensor Fish data overlaid on a cross section of Detroit Dam showing approximate locations for major timing marks during Sensor Fish passage from injection to draft tube exit.....	3.5
3.3	Sensor Fish data overlaid on a cross section of Detroit Dam showing approximate locations for major timing marks via the upper regulating outlet route.....	3.6
3.4	Mean, maximum, and minimum peak acceleration magnitudes for the most severe significant event observed per Sensor Fish release by spillbay location and gate opening.....	3.9
3.5	Mean acceleration magnitude for all Sensor Fish significant spillbay events by event location.....	3.10
3.6	Live-fish mortality and malady estimates contrasted with Sensor Fish significant event magnitudes for all evaluated passage routes at Detroit Dam.....	3.16
3.7	Relationship between live-fish estimated malady rate and the average magnitude of the most severe event experienced per release for spillway passage.....	3.18
3.8	Fit of linear model relating live-fish 48-hr mortality rate and the average magnitude of the most severe event experienced per release for all evaluated passage routes at Detroit Dam.....	3.19
3.9	High speed photograph of a live fish encountering a high-velocity jet, thereby experiencing exposure to high shear.....	3.20
3.10	Fit of linear model between live-fish estimated malady rate and Sensor Fish turbulence index.....	3.21
4.1	Spillbay 3 at Detroit Dam showing the rough, irregular concrete surface.....	4.1
4.2	Spillbay 6, 3.5-ft gate opening, showing walls confining the turbulent flow created on the rough spillway chute.....	4.2
4.3	Flow through Spillbay 3, 1.5-ft gate opening spreads to adjoining spillbays.....	4.2
4.4	A hydraulic jump carries the Sensor Fish down the spillway chute as flow passes under the tainter gate in Spillbay 3 with the gate open 1.5 ft.....	4.4
4.5	Chips and scratches visible on the polycarbonate Sensor Fish casing.....	4.5

4.6	Cross section of a Francis turbine showing the midline of the scroll case and wicket gates at the same elevation as that of the outer edge of the turbine runner blades.....	4.7
4.7	Cross section of a Kaplan turbine showing the wicket gates located above the turbine runner .....	4.8
4.8	Regulating outlet discharge at Detroit Dam when the control gate was open 1 ft. ....	4.10
4.9	Regulating outlet discharge at Detroit Dam when the control gate was open 5 ft. ....	4.10
4.10	Computational fluid dynamics estimate of water velocity through the RO when the control gate was open 5 ft.....	4.11
4.11	Sensor Fish pressure time histories for passage through the RO from injection through passage under the RO control gate for control gate settings of 1 ft and 5 ft. ....	4.12
4.12	Computational fluid dynamics estimate of water velocity through the RO when the control gate was open 1 ft.....	4.13
4.13	Large fish entrained within the force of rapidly accelerating water are exposed to injury from water moving at a higher velocity than their body .....	4.13
4.14	Small fish, with less inertia, are carried with the force of rapidly accelerating water surrounding their body. ....	4.14

## Tables

3.1	Number of Sensor Fish releases by study treatment during the July 2009 spillway evaluation.....	3.1
3.2	Number of Sensor Fish releases by study treatment during the October 2009 penstock/turbine evaluation .....	3.2
3.3	Number of Sensor Fish releases by study treatment during the December 2009 regulating outlet evaluation.....	3.2
3.4	Sensor Fish releases for each spillbay showing location and type of most severe significant event observed.....	3.8
3.5	Location and frequency of occurrence of all Sensor Fish significant events by event location and type .....	3.8
3.6	Sensor Fish penstock/turbine releases showing location of occurrence and type of the most severe significant events observed .....	3.10
3.7	Location and frequency of occurrence of all Sensor Fish significant events by event location and type .....	3.10
3.8	Sensor Fish releases for each regulating outlet gate opening showing location and type of most severe significant event observed .....	3.12
3.9.	Location and frequency of occurrence of all significant events for Sensor Fish passage through the regulating outlet showing event location and type .....	3.12
3.10.	Computed area under the curve for angular rate-of-change and acceleration magnitudes for each passage route and treatment condition .....	3.13
3.11	Survival and malady-free rates for rainbow trout spillway passage at Detroit Dam, July 2009.....	3.14
3.12	Survival and malady-free rates for rainbow trout passage through the turbine at Detroit Dam, October 2009.....	3.14
3.13	Survival and malady-free rates for rainbow trout passage through the regulating outlet at Detroit Dam, December 2009 .....	3.15

## 1.0 Introduction

Salmonid survival has been impacted by the construction of dams on the North Santiam River in Oregon. Dams have obstructed upstream passage and habitat for spawning and rearing, as well as altered downstream flows and water temperature patterns, contributing to species decline. Temperature requirements are currently being assessed and monitored at Detroit Dam.

Detroit Dam, used primarily for flood control, recreation, municipal and irrigation water, and power production, normally does not spill during salmonid migration periods. Three routes are available for downstream egress: a spillway with six spillbays; four regulating outlets (ROs), two at two separate elevations; and two turbines with their associated penstocks.

Prior to 2007, project flows were typically routed through the powerhouse. In summer, with Detroit Lake at full pool, hypolimnetic flows discharged through the turbines produced cooler downstream temperatures, negatively affecting fish productivity and abundance. During the fall and early winter, the reservoir was drawn down using the upper ROs and turbine flows, which, as the forebay level lowered, introduced warmer water downstream. A fire in the Detroit Dam powerhouse in 2007 disabled both turbine units, forcing spill. The spill flows initially increased the downstream temperatures but were balanced with RO releases, providing improved conditions for fish survival. The option of combining the spill of warmer surface water with the colder turbine flows over the summer and fall to aid in the regulation of water temperature for fish health is being evaluated as part of the *2008 Willamette Project Biological Opinion* (NMFS 2008).

This report documents an investigation of spill passage conditions at Detroit Dam in July 2009 (Duncan 2010), turbine passage in October 2009, and RO passage in December 2009. The studies were conducted by Pacific Northwest National Laboratory (PNNL) for the U.S. Army Corps of Engineers (USACE), Portland District, and performed concurrently with HI-Z-tag studies of passage survival for rainbow trout conducted by Normandeau Associates, Inc.

This study will provide information for evaluation of spill, turbine, or RO operation alternatives to optimize downstream temperatures and improve fish survival.

### 1.1 Objectives

The objectives of this study were

- to describe and compare passage exposure conditions through Spillbay 3 and Spillbay 6 at two spillgate openings (i.e., spillway discharges)
- to describe passage exposure conditions encountered during passage through the intake, runner region, draft tube, and tailrace of Francis turbine Unit 2
- to describe passage exposure conditions through a RO at two gate openings
- to describe differences in passage conditions between the passage routes
- to identify regions in all passage routes where passage conditions are potentially injurious to fish.

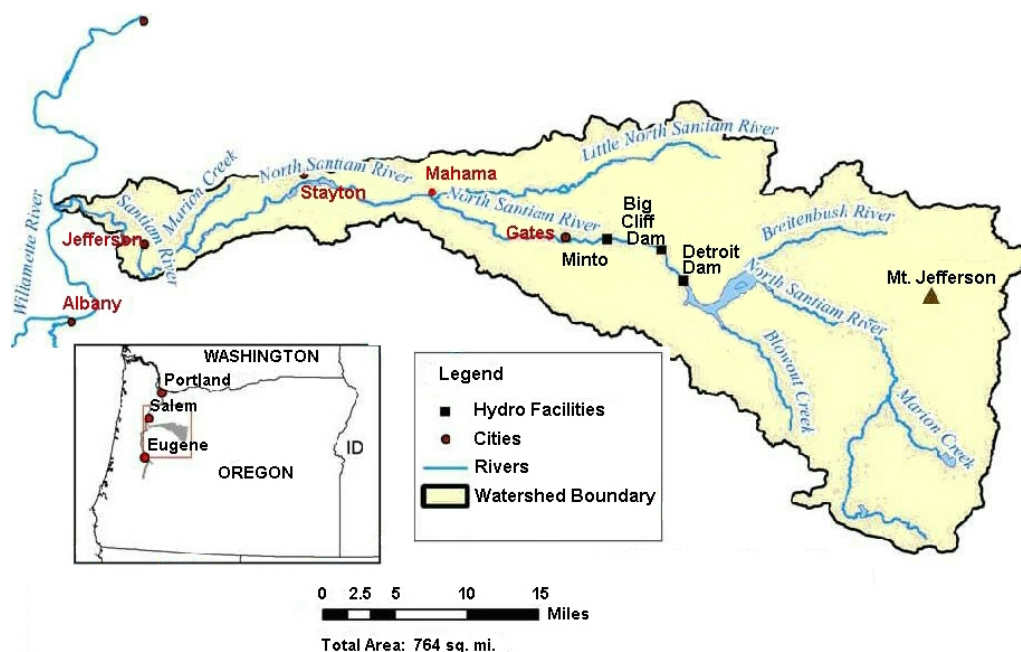
## **1.2 Report Overview**

Chapter 2 describes the methods, including the study site and the Sensor Fish device. Chapter 3 presents the results of the study, followed by a discussion in Chapter 4. Conclusions are offered in Chapter 5, followed by Chapter 6, the sources cited in this report. The compact disk included in the pocket on the inside back cover of printed copies of this report contains supplementary details and data in four appendices. Appendix A contains field log data that provide dam operating conditions, release elevations, and deployment and recovery times for each Sensor Fish release. Appendix B provides summary data tables for each Sensor Fish release. Dam operating conditions, exposure event descriptions, pressure at injection, and rates of change in pressure are included in the data tables. Appendices C and D present graphics showing pressure, acceleration magnitude, and angular rate of change magnitude time histories for each Sensor Fish release.

## 2.0 Methods

### 2.1 Study Site

Detroit Dam, located at river mile 60.9 of the North Santiam River in Marion County, Oregon, is a storage dam used for flood control, power generation, irrigation, navigation, and recreation (Figure 2.1). The dam, a concrete gravity structure approximately 463 ft tall and 1580 ft long, has a gated spillway with six spillbays (Figure 2.2). Only Spillbay 6 has guidewalls, which limits spillflow interaction with the adjacent spillbay. The spillway crest is located at elevation 1541 ft above mean sea level (MSL), and full pool is at 1569.0 ft MSL; minimum pool is at 1450.0 ft MSL.



**Figure 2.1.** Detroit Dam on the North Santiam River.

In addition, the project has four ROs extending through the dam with discharge outlets at the face of the spillway, two at an invert elevation of 1265.3 ft MSL and two at 1340 ft MSL; horizontally the ROs are positioned approximately 100 ft apart (Figure 2.2). The ROs are controlled by hydraulically powered gates located within the RO conduit approximately 40 ft downstream of the RO intake and 275 ft upstream of the RO outlet. Regulating outlet discharge is a function of forebay depth and gate opening. In front of the gate, the conduit is approximately 5.7 ft wide and 10 ft high; behind the gate, the conduit is 16 ft high and 7 ft wide. The RO conduit exits the face of the spillway, plunging into the tailrace.

Detroit Dam has a powerhouse containing two Francis turbine units with a hydraulic capacity of 5340 cubic feet per second (cfs) and a total capacity of 100 megawatts (MW). The entrance to the 15-ft diameter turbine penstock is located at an elevation of 1403.0 ft MSL, descending to an elevation of 1203.0 ft MSL at the turbine wicket gates (Figure 2.3). Each Francis turbine at Detroit Dam operates at 70,000 horsepower and 163.6 revolutions per minute. The runner diameter is 130 in., and the runner opening height is 49.5 in. The velocity of the periphery of the runner is 92.8 feet per second (fps). Maximum discharge is 5340 cfs, and there are 13 blades and 24 wicket gates.

The stilling basin contains dentates, and floor elevation is approximately 1170 ft MSL. No fish bypass routes or migrant collection facilities currently are available at Detroit Dam. Downstream fish passage is available only through the spillway, turbines, or ROs.

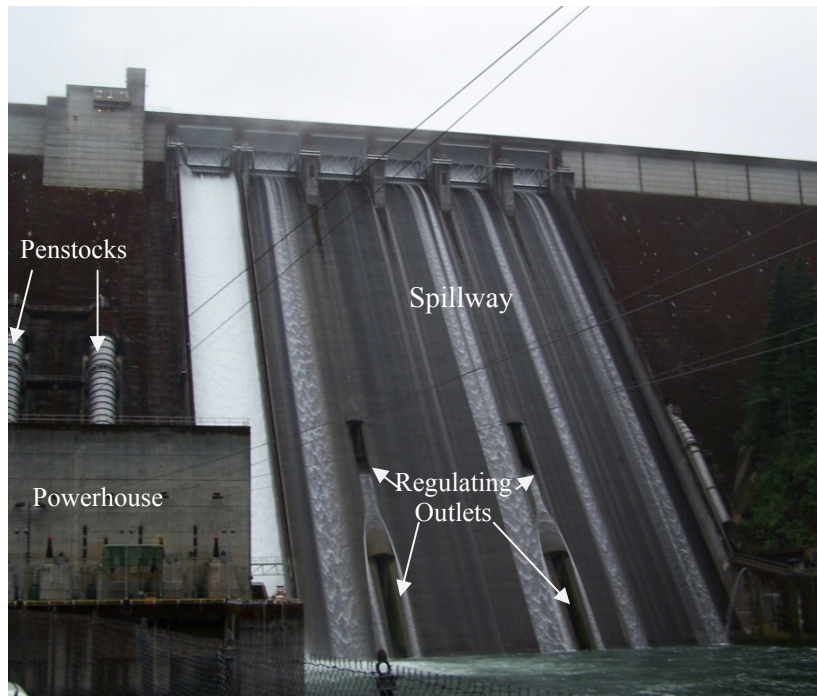


Figure 2.2. Detroit Dam, Oregon.

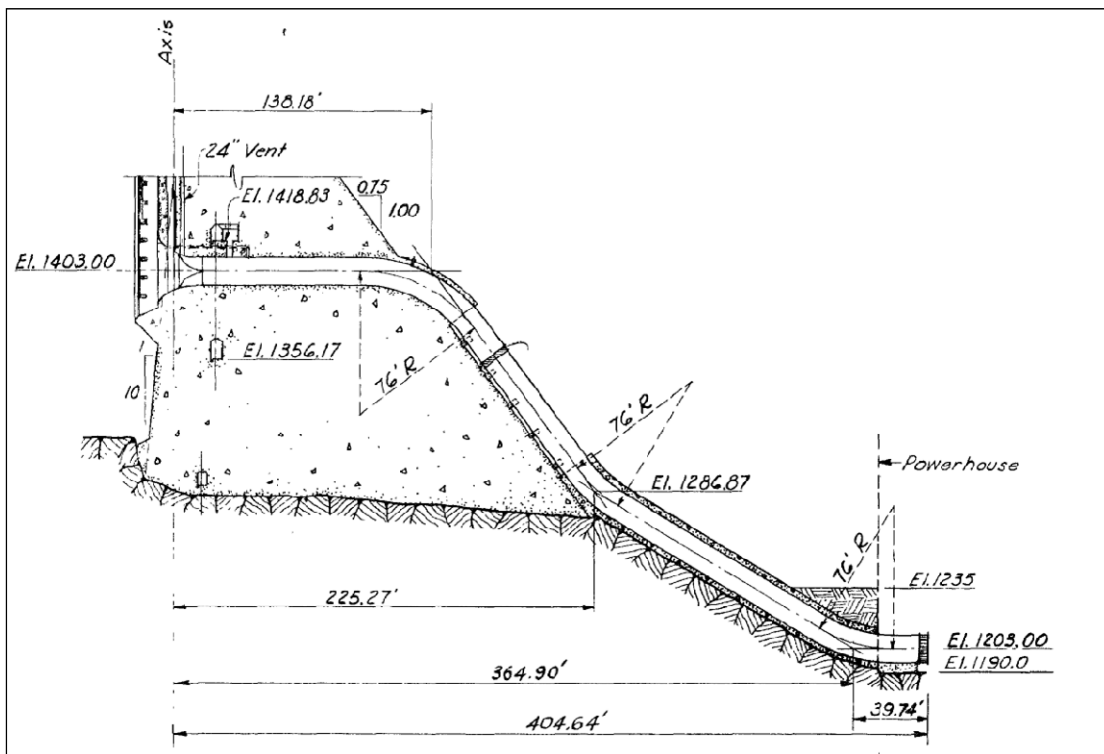


Figure 2.3. Cross section of a Detroit Dam penstock.



## 2.2 Sensor Fish Device

The Sensor Fish housing is constructed of clear polycarbonate plastic (Figure 2.4). It is 24.5 mm in diameter and 90 mm long and weighs 43 grams. The Sensor Fish is nearly neutrally buoyant in fresh water. The Sensor Fish measures the three components of linear acceleration, the three components of angular velocity (these together comprise the six degrees of freedom), absolute pressure, and temperature, at a sampling frequency of 2,000 Hz per sensor channel over a recording time of about 4 min.

The Sensor Fish consists of modules that charge its internal battery, program the sensor settings, acquire data, and convert from analog signal to digital form. The acquired data are stored in an internal memory card and transferred to computers via a wireless infrared link using an external infrared link modem. Sensor Fish are deployed, acquiring data in response to hydraulic conditions and interaction with structure; units are retrieved; and the data are downloaded, analyzed, and interpreted.



**Figure 2.4.** Six-degree-of-freedom Sensor Fish device.

Retrieval of the Sensor Fish is aided by the attachment of a micro-radio transmitter (Advanced Telemetry Systems, Isanti, Minnesota) and HI-Z balloon tags (Normandeau Associates, Inc., Bedford, New Hampshire), which are identical to those used for live test fish (Heisey et al. 1992). HI-Z tags contain a water-soluble capsule filled with a chemical that produces gas when activated with water, a process that takes approximately 3 min following initiation. The balloons inflate sufficiently to bring the Sensor Fish to the surface for recovery, and a directional radio receiver antenna used by boaters in the tailrace homes in on the radio transmitter attached to the Sensor Fish.

## 2.3 Procedures

Sensor Fish releases were interspersed with releases of HI-Z balloon-tagged live fish through the same release pipes used by Normandeau Associates, Inc. to release balloon-tagged fish. Study plans called for one Sensor Fish release for every 10 live-fish treatment releases, when feasible. Due to the uncertainty of Sensor Fish condition following passage and need to limit the losses of Sensor Fish, after a Sensor Fish was lost or damaged, the USACE was contacted for authorization to proceed with additional Sensor Fish releases.

### 2.3.1 Spillway Evaluation

Sensor Fish releases were made into Spillbays 3 and 6. Sensor Fish were injected into spillway approach flow through induction systems consisting of large-diameter (4-in.) stainless steel pipes with flexible hose attachments, installed approximately mid-bay. The piping installed in each spillbay extended vertically from the spill deck into the water in the forebay immediately upstream of the test spillbay. Flexible hosing (4-in.-diameter) connected the terminus of the steel pipe to the outlet of the modified head tanks where live fish and Sensor Fish were introduced into the injection systems. Control releases were made through an equivalent induction system located downstream of the Spillbay 6 stilling basin, using a 4-in. flexible pipe extending from the dam turbine discharge deck into the tailrace.

A computational fluid dynamics (CFD) model was used to simulate spillway approach flows for gate openings of 1.5 ft and 3.5 ft. The simulated flow fields were analyzed to identify elevations for introduction of live fish and Sensor Fish so that they would enter the spillbay approach flow at water velocities of approximately 5 fps. Spillway discharge increases with gate opening; a 1.5-ft spillgate opening permits a discharge of approximately 1560 cfs flow, and a 3.5-ft opening gives a discharge of approximately 3010 cfs. The pipe terminus for the higher flow (3.5-ft gate opening) was positioned approximately 3 ft above the elevation of the spillway crest at approximately 1544 ft MSL; the pipe for the lower flow (1.5-ft gate opening) extended approximately 4 ft downstream below the elevation of the spillway crest, with the terminus located at approximately 1542.5 ft MSL. Both pipes were positioned approximately 3 ft above any spillway structure. Control fish were released into the Spillway 6 tailrace at both the 1.5- and 3.5-ft spillgate openings test conditions.

### 2.3.2 Penstock/Turbine Assessment

Sensor Fish releases were made into the turbine Unit 2 penstock using an induction system similar to that used for the spillway evaluations. Flexible 4-in. hosing extended from a head tank located on the powerhouse intake deck through a stainless steel pipe positioned in the head gate slot, which is located downstream of the turbine penstock trash racks. The injection pipe terminus was positioned at approximately 1409 ft MSL, 1.5 ft below the penstock ceiling. Water velocity near the release pipe terminus was estimated to be approximately 12.5 fps (Phillips 2010<sup>1</sup>). The penstock conducts flow to the Francis turbine unit, located approximately 200 ft below the turbine intake deck at an elevation of 1203 ft MSL.

### 2.3.3 Regulating Outlet Evaluation

Sensor Fish releases were made from the forebay into the upper RO located on the north side of the spillway. The induction system head tank was positioned on a barge in the dam forebay, and a flexible 4-in. hose extended to a stainless steel pipe supported by a frame similar to that used in the penstock releases. The pipe terminus was positioned at approximately 1343 ft MSL, 3 ft above the RO centerline elevation and 2 ft below the ceiling. Two RO discharge control gate openings, 1 ft and 5 ft, with discharges of approximately 460 cfs and 1800 cfs, respectively, were evaluated during the study. Computational fluid dynamics modeling indicated flow velocities at the pipe terminus to be approximately 4 and 18 fps for the 1-ft and 5-ft openings, respectively.

---

<sup>1</sup> Phillips M. 2010. Memorandum from M Phillips (CENWP-EC-HD) to D Griffith and T Kuhn (CENWP-PM-E), "Detroit Dam Direct Mortality Studies – Velocity Analysis for Preferred Release Locations for Regulating Outlet and Turbine Penstock," May 14, 2010, Portland, Oregon.

## 2.4 Data Analysis

Sensor Fish data sets consist of time histories of angular motion (pitch, roll, and yaw), pressure, acceleration ( $x$ ,  $y$ , and  $z$  axes), temperature, and battery status extending from the time of release through the period of data acquisition programmed into the Sensor Fish (Deng et al. 2007a). Data time histories contain a data point for each transducer every 0.0005 s. This time interval between digital samples corresponds to a 2,000-Hz sampling rate for each of the analog outputs from Sensor Fish acceleration, rotation, and pressure sensors. Sampling of all analog data streams occurs nearly simultaneously within each sampling interval.

Water depth in feet is estimated, when appropriate, from absolute pressure at various points along each Sensor Fish route by subtracting atmospheric pressure, determined at the time of the release of each Sensor Fish, and dividing the resulting gauge pressure by 0.4335, the pressure in pounds per square inch of 12 in. of fresh (distilled) water at 39.2°F (4°C). The raw output of the triaxial accelerometers is processed to detect and quantify Sensor Fish response to turbulence, contact with structure (strike or collision), and shear. Acceleration vector magnitude is computed each sampling interval using triaxial accelerometer output and is one of the variables analyzed and reported to characterize passage conditions and the occurrence of strike, collision, and shear events. Triaxial angle rate-of-change data are processed to provide further information about the response of the Sensor Fish to flow conditions and is another measure of flow quality.

Analysis of the raw data from the Sensor Fish begins with preparation of plots showing absolute pressure, triaxial acceleration, and triaxial rotation. These records are visually inspected to identify prospective strike, collision, and shear events and to obtain a general overview of the passage conditions present for each test treatment. Changes in pressure during passage include features consistently present resulting from the design of passageway structures and the dynamics of water flow through the passageway. These features in the pressure time history permit acceleration and rotation data to be divided into segments corresponding to specific locations (zones) that extend from Sensor Fish injection to exit from the stilling basin. Each region is identified by characteristic features in the Sensor Fish pressure time history and characteristics in triaxial acceleration and rotation data. For each Sensor Fish data set, events of interest, such as rapid pressure changes, strikes, collisions, shear, and severe turbulence, are identified and quantified. Quantification of events includes the time of occurrence, location by zone, and extraction of information describing severity, as well as additional information to separate collisions from shear exposure.

## 3.0 Results

Detailed data on which this chapter is based are provided in the appendices provided on the compact disk in the pocket on the inside back cover of printed copies of this report. Appendix A contains study data that include the release and recovery times for each Sensor Fish, discharge measurements and other information describing the operation of the passage route for each Sensor Fish release, and other project information for the study period. Appendix B contains tables of observed maximum acceleration magnitudes, pressure rates of change, and computed release elevations for all Sensor Fish releases as well as dam operations data. Graphs with plots of pressure and acceleration magnitude for each successful Sensor Fish release are located in Appendix C, and those for pressure and angular rate-of-change magnitude are in Appendix D.

### 3.1 Treatment Release Data

Data were acquired from Sensor Fish following passage through Spillbays 3 and 6, turbine Unit 2, and the upper north side RO at Detroit Dam. Release and recovery information for each route follows.

#### 3.1.1 Spillway

A total of 109 Sensor Fish were released through the spillway at Detroit Dam between July 13 and July 21, 2009, with 91 data sets acquired (Table 3.1). A successful release requires both the recovery of the unit and successful download of acquired data. All Sensor Fish were recovered successfully. However, 18 data sets could not be downloaded due to damage to the Sensor Fish during passage. Injection pipe termini elevations were confirmed to be approximately 1544 ft MSL and 1542.5 ft MSL for the 3.5-ft and 1.5-ft gate openings, respectively. The forebay elevation was near full pool (1569 ft MSL) during the spillway study.

**Table 3.1.** Number of Sensor Fish releases by study treatment during the July 2009 spillway evaluation.

Spillbay	Gate Opening (ft)	Mean Forebay Elevation (ft MSL)	Mean Tailwater Elevation (ft MSL)	Mean Spillbay Q (cfs)	Mean Total Project Flow (cfs)	Total Number Released	Number of Sensors Damaged/Unusable <sup>(a)</sup>	Number of Usable Data Sets
3	1.5	1560.5	1200.7	1549.0	2455.3	30	6	24
3	3.5	1559.5	1201.4	2915.1	3375.1	10	3	7
6	1.5	1559.3	1200.8	1559.4	1558.9	18	1	17
6	3.5	1560.5	1200.7	3008.0	3385.1	32	6	26
Control	1.5	1560.2	1201.1	1548.4	2204.4	10	1	9
Control	3.5	1560.3	1200.7	2997.6	3488.1	9	1	8
<b>Total</b>						<b>109</b>	<b>18</b>	<b>91</b>

(a) Some Sensor Fish units were reused after attempted repairs.

### 3.1.2 Penstock/Turbine

A total of 25 Sensor Fish were released through the turbine via the penstock at Detroit Dam between October 20 and 21, 2009, with 20 data sets acquired. All Sensor Fish were recovered successfully. One nonfunctional Sensor Fish was released to evaluate passage retrieval conditions, three data sets could not be downloaded due to damage to the Sensor Fish during passage, and data from one control Sensor Fish were inadvertently deleted. The pipe terminus elevation for injection of Sensor Fish into the test turbine intake was confirmed to be at 1409 ft MSL. The forebay elevation for the turbine passage segment of this study was approximately 1513 ft MSL, 56 feet below the maximum pool elevation of 1569 ft MSL.

**Table 3.2.** Number of Sensor Fish releases by study treatment during the October 2009 penstock/turbine evaluation.

Turbine Unit	Mean Forebay Elevation (ft MSL)	Mean Tailwater Elevation (ft MSL)	Mean Turbine Discharge (cfs)	Mean Total Project Flow (cfs)	Total Number Released	Number of Sensors Damaged	Number of Usable Data Sets
2	1512.7	1202.1	2200	2200	23 <sup>(a)</sup>	3	19
Control	1513.2	1202.2	2200	2200	2	--	1
<b>Total</b>					<b>25</b>	<b>3</b>	<b>20</b>

(a) One nonfunctional Sensor Fish unit was released.

### 3.1.3 Regulating Outlet

A total of 38 Sensor Fish were released through the upper north regulating outlet between December 8 and 11, 2009, with 37 data sets acquired. All Sensor Fish were recovered successfully. One data set could not be downloaded due to damage to the Sensor Fish during passage. The pipe terminus elevation for the RO Sensor Fish injection system was confirmed to be at 1343 ft MSL. The forebay elevation at the time of this segment of the study was approximately 1441 ft MSL, near the 1450 ft MSL minimum pool elevation and nearly 130 ft below the maximum pool elevation of 1569 ft MSL.

**Table 3.3.** Number of Sensor Fish releases by study treatment during the December 2009 regulating outlet evaluation.

Regulating Outlet	Gate Opening (ft)	Mean Forebay Elevation (ft MSL)	Mean Tailwater Elevation (ft MSL)	Estimated RO Discharge (cfs)	Total Number Released	Number of Sensors Damaged	Number of Usable Data Sets
Upper North	1	1441.1	1202.4	460	18	1	17
Upper North	5	1440.5	1202.2	1800	19	0	19
Control		1441.0	1202.6		1	0	1
<b>Total</b>					<b>38</b>	<b>1</b>	<b>37</b>

## 3.2 Data Analysis

Sensor Fish data analysis included computing absolute and gauge pressure, acceleration magnitudes, and rotational magnitudes, and reviewing their time histories. Strike, collision, and/or shear events appear as high-amplitude impulses in acceleration magnitude time histories. To qualify as a significant event, a high-amplitude acceleration impulse must have a peak value equal to or greater than 95 g (Deng et al. 2007b). Significant events frequently also show concurrent high-amplitude pressure and rotation magnitude values, which aid in identifying the location of the event in time and space and in distinguishing collisions and strike events from shear events.

The location of a significant event is determined by the location of the impulse relative to distinctive, consistent features observed in the pressure time histories.

### 3.2.1 Spillway Passage

Timing marks used to locate significant events and identify regions of spillway passage include

1. passage through the tainter gate opening
2. impact of discharge jets on the spillway chutes and redirection of the spillway jet
3. passage along the spillway chute
4. plunge into the stilling basin
5. passage through the stilling basin to the tailrace surface.

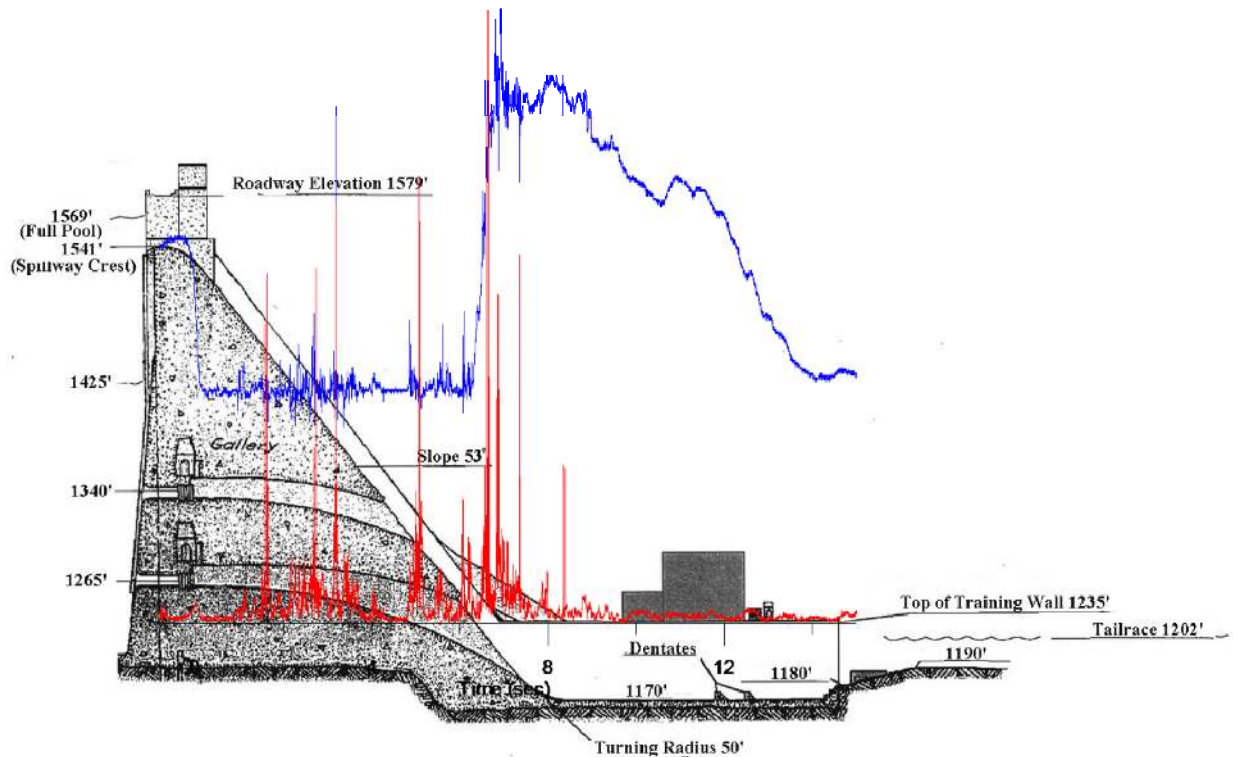
Examples of pressure timing marks used for the spillway study are shown in Figure 3.1. A large drop in pressure (shown by the blue line) occurs as the Sensor Fish passes under the tainter gate; during passage down the spillway chute, pressure is very nearly atmospheric, but is interrupted by numerous sharp impulses. The sharp impulses in pressure during passage of the Sensor Fish down the spillway chute are not changes in the depth of the sensor but are response of the pressure transducer to high energy collisions on the spillway surface, which are clearly shown in the acceleration magnitude data.

Following passage down the spillway chute, pressure increases as the Sensor Fish is carried to depth into the stilling basin. The Sensor Fish is exposed to the energy dissipating turbulence in the spillway stilling basin then carried downstream into the river where it is carried to the surface by the increased buoyancy of the slowly inflating balloons.

Due to the sharp, 53-degree angle of the spillway, Sensor Fish were carried with rapidly accelerating flow under the spillway tainter gate in well formed discharge jets and showed initial contact with the spillway chute at times following tainter gate passage that were a function of spillway discharge. In most cases, the discharge jet carried the Sensor Fish without the units experiencing a significant collision event (collision impulse with magnitude  $\geq 95$  g) at the point of discharge jet impact on the spillway concrete chute. However, Sensor Fish were more likely to have a significant collision event at impact of the discharge jet on the spillway chute when the spillway gate opening was 3.5 ft.

A total of 87.5% (21 of 24) of the Sensor Fish passing through Spillbay 3 and 88.2% (15 of 17) of those passing through Spillbay 6 at a 1.5 ft gate opening showed a delay between tainter gate passage and contact of the discharge jet on the spillway chute. Sensor Fish impacts were observed at 1.18 and 1.21 s

(mean values) following passage under the Spillbay 3 and Spillbay 6 tainter gates, respectively at a gate opening of 1.5 ft. At the 3.5-ft gate opening, Sensor Fish data showed contact of the discharge jet on the spillway chute at mean time delays of 0.72 and 1.07 s following tainter gate passage for Spillbay 3 and Spillbay 6, respectively, with 100% of the Sensor Fish releases into the former and 96% (25 of 26) of the latter showing impact of the outfall jet and Sensor Fish on the chute.



**Figure 3.1.** Sensor Fish data overlaid on a cross section of Detroit Dam showing the approximate locations for major timing marks during spillway passage. The blue line is pressure; the red line is acceleration vector magnitude in  $g$ .

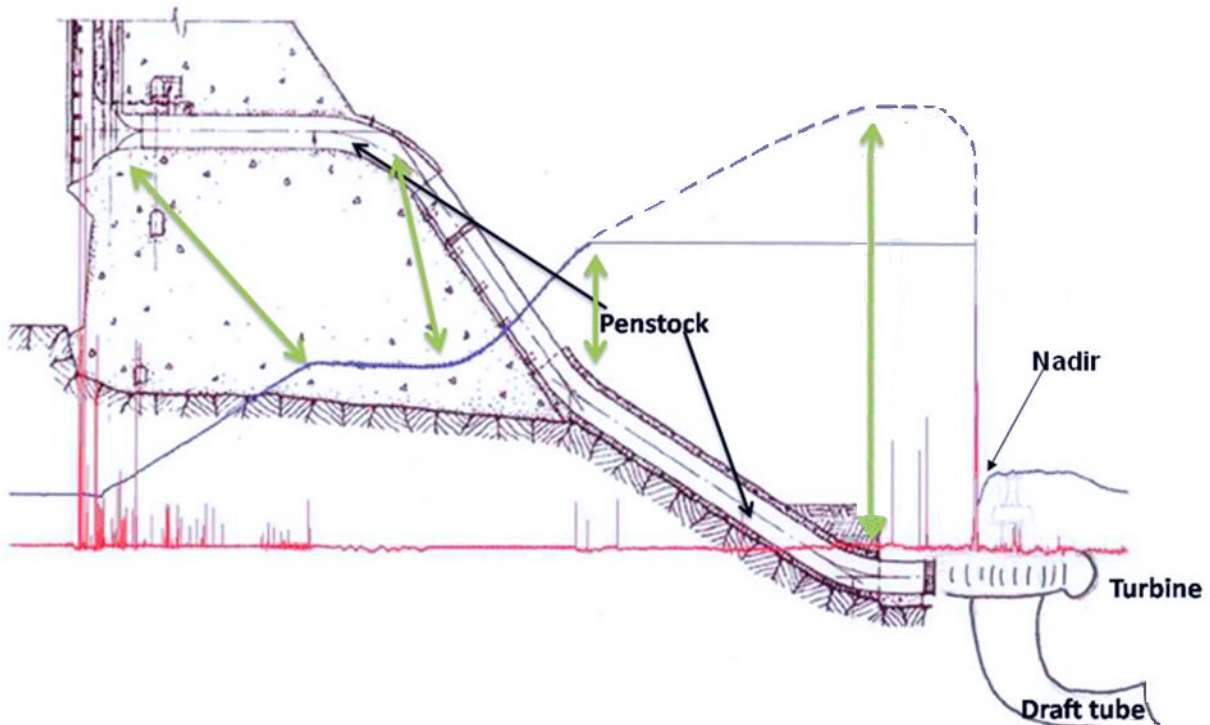
### 3.2.2 Penstock/Turbine Passage

Timing marks used to locate significant events and identify regions of penstock/turbine passage include

1. passage through the penstock
2. passage through the scroll case region
3. runner passage
4. the pressure nadir during passage through the runner
5. passage through the turbine draft tube
6. passage to the tailrace.

Examples of pressure timing marks used for the penstock/turbine study are shown in Figure 3.2. Pressure rises as the Sensor Fish passes down the induction pipe to the point of injection into the

penstock, leveling as it is carried with penstock flow through the horizontal section of the penstock. A flow transition is observed as the penstock curves, and pressure increases as penstock flow continues toward the turbine scroll case. A second transition approximately one-half the distance down the length of the penstock causes the slope of the pressure line to level slightly as the penstock gradient declines, after which pressure continues to increase. As the flow approaches the turbine, a third flow transition occurs and the pressure remains constant during scroll case passage on approach to the turbine wicket gates. As the Sensor Fish passes through the turbine runner, there is a rapid decrease in pressure, which reaches its lowest point, its nadir, during transit of the suction side of the turbine runner. Following passage through the turbine runner, the Sensor Fish is carried with flow through the turbine draft tube and into the powerhouse tailrace.



**Figure 3.2.** Sensor Fish data overlaid on a cross section of Detroit Dam showing approximate locations for major timing marks during Sensor Fish passage from injection to draft tube exit. The green arrows show flow transition regions and indicate where characteristic features of pressure and acceleration time histories map to physical features of the penstock and turbine. The blue line is pressure in psia; the red line is acceleration vector magnitude in g.

The pressure transducer on the Sensor Fish has a measurement range of 0 to 100 pounds per square inch absolute (psia). The hydraulic head at Detroit Dam was more than 300 ft during the study period, which, when converted to pressure is about 144 psia, exceeding the pressure sensor measurement range. At pressures higher than 100 psia, the pressure sensor does not show the actual pressure but reports its maximum value of 100 psia. As the pressure acting on the sensor drops below 100 psia, actual pressures are once again reported by the sensor. However, pressure values can be inferred (as shown on the dotted line in Figure 3.2) from the point at which water velocities become high, by noting the likely time-dependent elevation of the sensor relative to the level of water in the dam forebay.



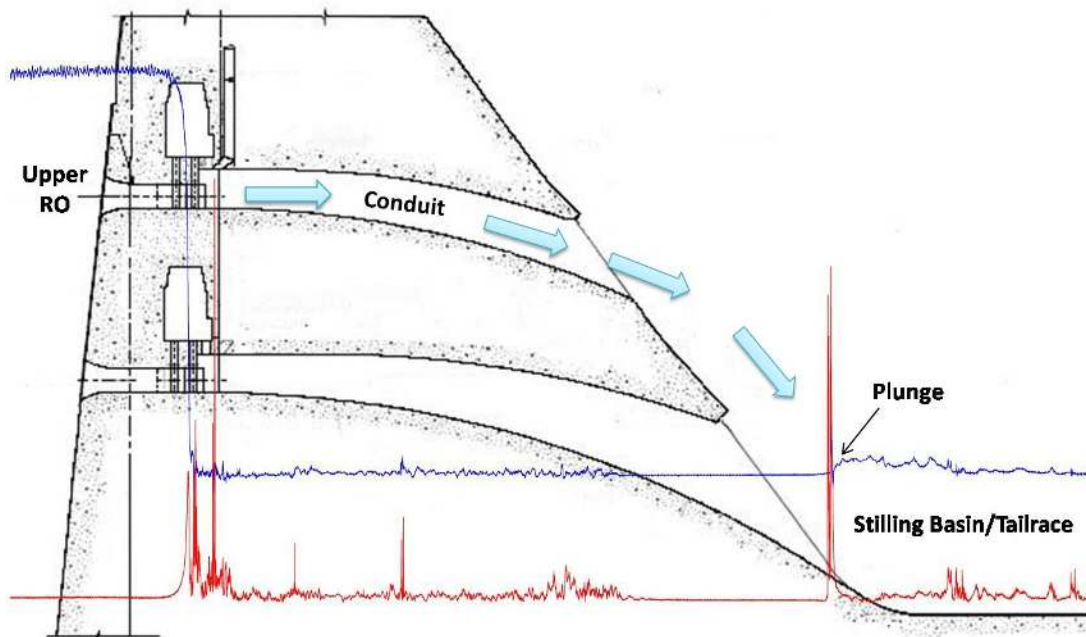
Nearly every Sensor Fish significant event observed during passage through the penstock and turbine occurred during passage through the turbine wicket gate–runner complex. Only one significant event was observed in the draft tube and another in the scroll case region.

### 3.2.3 Regulating Outlet Passage

Timing marks used to locate significant events and identify regions of RO passage include

1. passage through the RO gate opening
2. passage through the RO conduit extending through the dam
3. plunge into the stilling basin
4. passage to the tailrace surface.

Examples of pressure timing marks used for the RO are shown in Figure 3.3. Pressure is highest as the sensor exits the induction pipe and approaches the RO gate. A rapid decrease in pressure occurs as the Sensor Fish passes under the control gate and travels through the RO conduit. Flow through the conduit at small gate openings is at atmospheric pressure. At higher gate openings, it is possible the flow would fill the conduit and be pressurized through exit onto the spillway chute. Exiting at the spillway face, the discharge jet plunges into the spillway stilling basin near the foot of the spillway chute. When the operating gate was open 1 ft, all but one Sensor Fish had a significant impact event, presumably near the foot of the spillway chute where the stilling basin depth is shallow. Approximately 68% of the Sensor Fish experienced a significant event during passage through the 5-ft gate opening. It is possible that the trajectory of the discharge jet at the higher gate opening carried a little farther into the stilling basin than that of the lower discharge.



**Figure 3.3.** Sensor Fish data overlaid on a cross section of Detroit Dam showing approximate locations for major timing marks via the upper regulating outlet route. The blue line is pressure; the red line is acceleration vector magnitude in g.

### 3.3 Strike, Collision, and Shear Events

The majority of Sensor Fish experienced at least one significant event regardless of passage route during passage at Detroit Dam. We define a significant event as an impulse in acceleration magnitude greater than or equal to 95 g. Significant events are caused by strike, collision on structure, or exposure to shear. Overall, 97.7% of the Sensor Fish experienced at least one significant event during passage through all passage routes; 86% experienced multiple events. No significant events were observed for control releases.

#### 3.3.1 Spillway Passage

Almost all (98.6%) of the Sensor Fish released into the spillway experienced at least one significant event during passage; nearly 92% of the Sensor Fish experienced more than one significant event. No events were observed for control releases made into the dam tailrace. Approximately 16% of the Sensor Fish were damaged during spillway passage.

Table 3.4 shows the number of Sensor Fish data files analyzed by release location and type, and the location of the most severe significant event observed. Collisions on the spillway chute were the most frequently observed severe significant events. More than 90% of the most severe significant events observed for Sensor Fish following passage through the 1.5-ft gate opening (1560-cfs discharge) were collisions on the spillway chute; more than 70% were at that location following passage through the 3.5-ft gate opening (3090-cfs discharge). The most severe event per Sensor Fish release was rarely shear, as only three of the most severe events were of this type. However, all occurred following passage through Spillbay 6 at the 3.5-ft gate opening.

Table 3.5 summarizes the total number of significant collision and shear events by event type and location of occurrence, which includes multiple event occurrences per release. Sensor Fish passing in Spillbay 6 spill when the control gate was open 1.5 ft had the greatest number of significant events per release, averaging 5.71 events. The fewest events per release, averaging 4.88, occurred during passage with flow through Spillbay 3 at the same 1.5-ft gate opening.

Significant events most frequently occurred on the spillway chute regardless of spillbay or gate opening, followed by occurrence in the stilling basin/tailrace region. No significant events were observed during entry of spillway discharge into the stilling basin for Sensor Fish passing through Spillbay 3 at the 1.5-ft gate opening and only a few events were observed at the other treatments. The percentage of significant events in the stilling basin/tailrace region was slightly higher for Spillbay 3 than for Spillbay 6 when the control gate was open 3 ft. When the control gate was open 1.5 ft, the percentage of significant events was also greater following passage through Spillbay 3.

The frequency of occurrence for collision or shear significant events varied slightly with gate opening. Sensor Fish were more likely to experience shear when passing through the 3.5-ft gate opening. However, more than 90% of observed collisions occurred on the spillway chute, regardless of flow or release location.

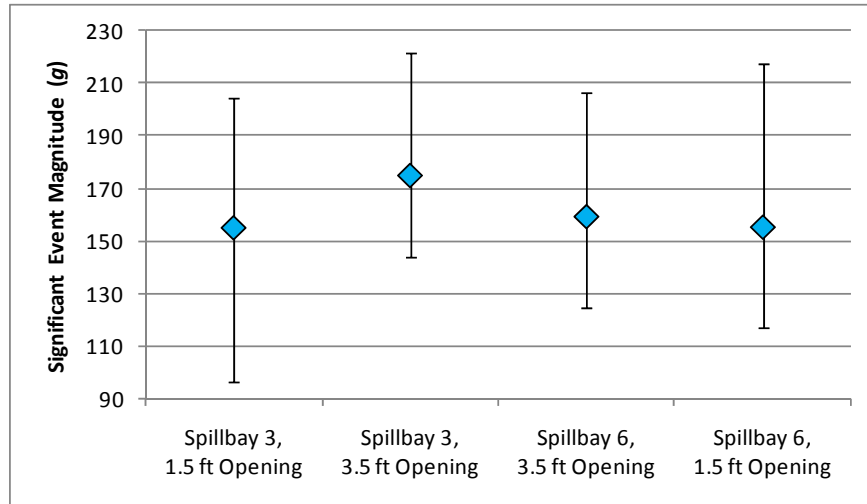
**Table 3.4.** Sensor Fish releases for each spillbay showing location and type of most severe significant event observed.

Release Location	Gate Opening	Number of Releases	Number of Sensor Fish Having at Least 1 Event $ a  > 95 g$	Frequency of Occurrence of the Most Severe Collision Events by Location			Frequency of Occurrence of the Most Severe Shear Events by Location			Frequency of Occurrence of the Most Severe Events by Location		
				Chute	Plunge	Stilling Basin/ Tailrace	Chute	Plunge	Stilling Basin/ Tailrace	Chute	Plunge	Stilling Basin/ Tailrace
Spillbay 3	1.5 ft	24	24	0.92	0	0.08	0	0	0	0.92	0	0.08
Spillbay 3	3.5 ft	7	7	0.71	0	0.29	0	0	0	0.71	0	0.29
Spillbay 6	1.5 ft	17	17	0.94	0	0.06	0	0	0	0.94	0	0.06
Spillbay 6	3.5 ft	26	25	0.72	0	0.16	0.08	0	0.04	0.80	0	0.20

**Table 3.5.** Location and frequency of occurrence of all Sensor Fish significant events by event location and type.

	Number of Releases	No Event	Single Event	>1 Event	Total Number of Events	Average Number Events per Condition	Event Location and Type						
							Chute		Plunge		Stilling Basin/ Tailrace		
							Collision	Shear	Collision	Shear	Collision	Shear	
Spillbay 3, 1.5-ft opening	24	0	3	21	117	4.88	0.82	0	0	0	0	0.16	0.02
Spillbay 3, 3.5-ft opening	7	0	0	7	37	5.29	0.70	0.03	0.03	0	0	0.19	0.05
Spillbay 6, 1.5-ft opening	17	0	0	17	97	5.71	0.81	0	0.03	0	0	0.14	0.01
Spillbay 6, 3.5-ft opening	26	1	2	23	132	5.28	0.74	0.02	0.01	0.01	0.01	0.18	0.05

The mean, maximum, and minimum acceleration magnitude values for the most severe events are shown in Figure 3.4. Sensor Fish passing through the 3.5-ft gate opening of Spillway 3 had the highest significant event mean magnitude (175.03 g), and sensors released through the 1.5-ft opening of the same spillbay had the lowest mean magnitude (154.7 g) for the most severe event observed per release. When this is compared to multiple events per condition, again the highest mean acceleration magnitude was for Sensor Fish passing through the 3.5-ft gate opening of Spillway 3 (131.34 g), and the lowest mean magnitude was for passage through the 1.5-ft gate opening of Spillbay 6 (129.02 g) (Appendix B).



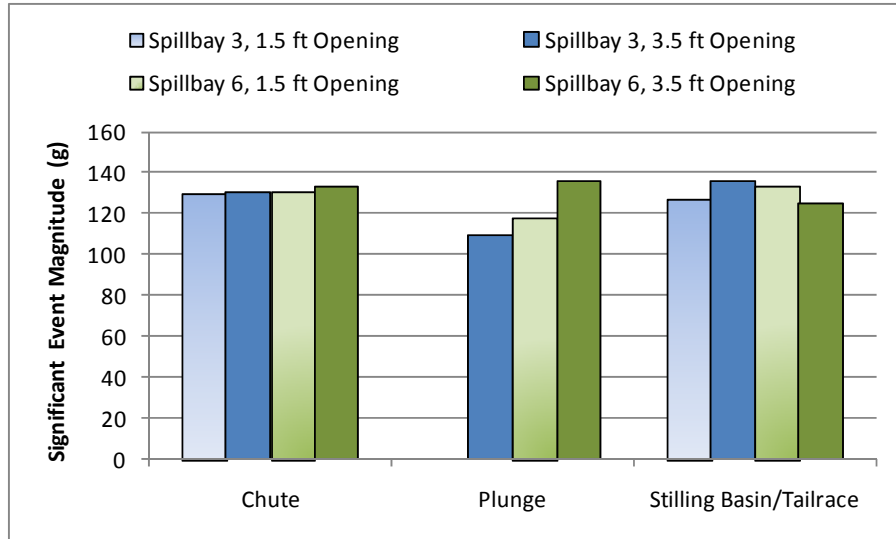
**Figure 3.4.** Mean, maximum, and minimum peak acceleration magnitudes for the most severe significant event observed per Sensor Fish release by spillbay location and gate opening.

The mean acceleration magnitude values for multiple Sensor Fish significant events by event location are shown in Figure 3.5. Overall, the magnitude of significant events was high and fairly uniform across all locations. The highest significant event magnitudes were observed in the stilling basin/tailrace region for Spillbay 6 releases. The magnitudes of significant events observed to occur on the spillway chute for all releases were virtually equivalent, with slightly higher values for the releases through Spillbay 6, at the 3.5-ft gate opening. The end of the spillway chute, where the flow plunges into the stilling basin, saw the highest values for Spillbay 6, 3.5-ft gate opening passage as well. No significant events were observed in the plunge region for the Spillbay 3, 1.5-ft gate opening.

### 3.3.2 Penstock/Turbine Passage

All of the Sensor Fish experienced multiple significant events during penstock/turbine passage. No events were observed for control releases into the tailrace. Damage to Sensor Fish during passage through the turbine was high; 13.6% of the units released showed severe damage to the printed circuit boards. Board fragments were visible inside the polycarbonate casing at recovery.

Table 3.6 shows the number of successful Sensor Fish releases and the type and location of the most severe significant event. All of the most severe events occurred in the wicket gate–runner region of the turbine, with 58% of the observed events classified as shear. The total number of events experienced during penstock/turbine passage is summarized in Table 3.7. An average of 5.0 events was experienced by Sensor Fish per release.



**Figure 3.5.** Mean acceleration magnitude for all Sensor Fish significant spillbay events by event location.

**Table 3.6.** Sensor Fish penstock/turbine releases showing location of occurrence and type of the most severe significant events observed.

Number of Releases	Number of Sensor Fish Having at Least 1 Event $ a  > 95 \text{ g}$	Frequency of Occurrence of the Most Severe Collision/Strike Events by Location			Frequency of Occurrence of the Most Severe Shear Events by Location			Frequency of Occurrence of the Most Severe Events by Location		
		Scroll Case	Runner	Draft Tube	Scroll Case	Runner	Draft Tube	Scroll Case	Runner	Draft Tube
19	19	0	0.42	0	0	0.58	0	0	1.0	0

**Table 3.7.** Location and frequency of occurrence of all Sensor Fish significant events by event location and type.

Number of Releases	No Event	Single Event	>1 Event	Total Number of Events	Average Number Events (All Releases)	Event Location and Type					
						Scroll Case		Runner		Draft Tube	
						Collision	Shear	Collision/Strike	Shear	Collision	Shear
19	0	0	19	95	5.0	0.01	0	0.34	0.64	0.01	0

Multiple significant events were observed most frequently in the wicket gate–runner complex region (98%), and approximately 64% of these events were due to shear. In addition, one significant event occurred in the scroll case region and one in the draft tube region. Events observed in the draft tube and scroll case regions were classified as collision on structure. No significant events were observed to occur during passage through the turbine penstock.

A rapid pressure decrease occurs during passage through the turbine runner region as the sensor is carried with flow from the pressure to suction sides of the turbine runner. The lowest pressure (nadir) observed during turbine passage occurs as flow passes under the runner blade prior to draft tube entry. The mean nadir value for Sensor Fish passage through the Francis turbine at Detroit Dam was 6.19 psia; the minimum nadir pressure observed was 0.93 psia, and the maximum was 9.93 psia ( $n = 19$ ; standard error = 0.68). Rapid decompression has been shown to injure or kill fish acclimated to depth (Brown et al. 2007, 2009). The average maximum rate of change in pressure experienced by Sensor Fish during passage under the runner blade was  $-1112.5$  psia/s. The maximum rate of change in pressure observed was  $-1654.6$  psia/s; the minimum was  $-678$  psia/s ( $n = 19$ , standard error = 71.3).

Significant event magnitudes observed during passage through the turbine at Detroit Dam were the highest observed for turbine passage by Sensor Fish to date, with a maximum value of 234.8 g. Mean magnitude for the most severe event per release was 176.5 g; minimum was 118.7 g. The mean magnitude for all significant events observed during turbine passage was 144.6 g.

### 3.3.3 Regulating Outlet Passage

A total of 94.4% of the Sensor Fish experienced at least one significant event during RO passage; nearly 67% of the Sensor Fish experienced multiple significant events. No significant events were observed for the control release. One Sensor Fish was damaged during passage through the 1-ft gate opening of the RO.

Table 3.8 shows the number of Sensor Fish releases and the type and location of the most severe significant event. The majority of severe events for both gate openings was due to shear and occurred where the RO flow jet plunges into the stilling basin. There were also numerous collision events in the RO conduit between the gate and its exit on the face of the spillway. One shear event occurred at the gate during passage through the 1-ft gate opening, and three collision events and one shear event were observed in the stilling basin/tailrace region following passage through the 5-ft opening.

Table 3.9 summarizes all RO significant collision and shear events by type and location. Multiple events were most frequent during passage through the 1-ft gate opening, averaging 3 events per release. Multiple events averaged 1.6 events per release for the 5-ft gate opening.

In addition to the difference in the number of events per release between test conditions, passage conditions immediately downstream of the control gate were also clearly different for the two test conditions. Seventy-one percent of the Sensor Fish passing through the 1-ft gate opening experienced a collision event immediately following gate passage. No similar collisions were observed for Sensor Fish passage through the 5-ft opening.

**Table 3.8.** Sensor Fish releases for each regulating outlet gate opening showing location and type of most severe significant event observed.

Gate Opening	Number of Releases	Number of Sensor Fish Having at Least 1 Event $ a  > 95 g$	Frequency of Occurrence of the Most Severe Collision Events by Location				Frequency of Occurrence of the Most Severe Shear Events by Location				Frequency of Occurrence of the Most Severe Events by Location			
			Gate	Conduit	Plunge	Stilling Basin/ Tailrace	Gate	Conduit	Plunge	Stilling Basin/ Tailrace	Gate	Conduit	Plunge	Stilling Basin/ Tailrace
1 ft	17	17	0	0.29	0	0	0.06	0	0.65	0	0.06	0.29	0.65	0
5 ft	19	17	0	0.24	0	0.18	0	0	0.53	0.06	0	0.235	0.53	0.235

**Table 3.9.** Location and frequency of occurrence of all significant events for Sensor Fish passage through the regulating outlet showing event location and type.

Gate Open	Number of Releases	No Event	Single Event	>1 Event	Total Number of Events	Average Number Events per Condition	Event Location and Type									
							Gate		Conduit		Flow Jet Before Plunge (Air)		Plunge		Stilling Basin/ Tailrace	
							Collision	Shear	Collision	Shear	Collision	Shear	Collision	Shear	Collision	Shear
1 ft	17	0	1	16	51	3	0	0.02	0.59	0	0.02	0	0.04	0.27	0.02	0.04
5 ft	19	2	8	9	30	1.58	0	0	0.30	0	0	0	0.03	0.40	0.13	0.13

The mean acceleration magnitude values for the most severe events experienced by Sensor Fish during passage through the 5-ft gate opening had the highest value (144.15 g). Sensors released through the 1-ft opening had an average magnitude of 141.56 g. Comparing these values to the total number of events per condition, again the highest mean acceleration magnitude was for Sensor Fish passing through the 5-ft gate opening (130.96 g vs. 122.3 g).

### 3.4 Turbulence Index

The turbulence index as it is used here is a subjective measure developed by computing the area (integrating) under the acceleration magnitude and angular rate-of-change magnitude curves for a given period, with the premise that larger area equates to greater turbulence. For the spillway evaluation, the first 15 s following passage under the tainter gate was used for computations. A 3-s period was used for the turbine study, 1 s prior to the runner nadir and 2 subsequent seconds. The 10-s period following gate passage was applied for the RO study. Each time segment encompasses the most turbulent passage interval for all passage treatments. Computed areas were normalized to seconds for evaluation purposes.

Turbulence index values were highest for Spillbay 3 passage for the 3.5-ft gate opening operation, followed by Spillbay 6 at the same gate setting. The turbulence index value for turbine passage is greater than the values for lower-flow spillway passage. The RO 5-ft opening had the lowest index value (Table 3.10).

**Table 3.10.** Computed area under the curve for angular rate-of-change and acceleration magnitudes for each passage route and treatment condition.

Passage Route and Condition	Area – Acceleration Magnitude per Second	Area – Angular Rate-of-Change Magnitude per Second	Combined Area per Second
Spillbay 3, 1.5-ft gate opening	3.07	918.05	921.12
Spillbay 3, 3.5-ft gate opening	3.98	1117.43	1121.41
Spillbay 6, 1.5-ft gate opening	3.34	947.9	951.24
Spillbay 6, 3.5-ft gate opening	3.93	1035.11	1039.04
Turbine Unit 2	7.40	948.45	955.85
Upper RO, 1-ft opening	2.92	790.94	793.86
Upper RO, 5-ft opening	2.96	722.21	725.17

### 3.5 Comparison of Sensor Fish and Live-Fish Data

Live-fish HI-Z-tag studies were conducted by Normandeau Associates, Inc., concurrently with the Sensor Fish studies at Detroit Dam. Normandeau scientists released live fish through the same injection systems as the Sensor Fish, under the same test conditions. Sensor Fish releases were interspersed with live-fish releases.

Approximately 1500 juvenile rainbow trout (104–171 mm; mean 125 mm total length [Normandeau 2010]) and 109 Sensor Fish were released during the spillway evaluation at Detroit Dam in July 2009. **Error! Not a valid bookmark self-reference.** shows fish release and recapture rates, estimated survival rate, and malady-free rate for live fish (Normandeau 2010). In October, 220 rainbow trout (112–246 mm;



mean 191 mm total length [Normandeau 2010]) and 25 Sensor Fish were released through the turbine (Table 3.12). In December, 400 rainbow trout (122–218 mm; mean 185 mm total length [Normandeau 2010]) and 38 Sensor Fish were released through the regulating outlet (Table 3.13).

**Table 3.11.** Survival and malady-free rates (with 95% confidence intervals [CIs]) for rainbow trout spillway passage at Detroit Dam, July 2009 (Normandeau 2010).

Passage Location	Spillbay 6		Spillbay 3		Control Combined
	Deep		Deep		
<b>Gate opening</b>	<b>3.5 ft</b>	<b>1.5 ft</b>	<b>3.5 ft</b>	<b>1.5 ft</b>	
Number released	320	304	298	298	290
Number recaptured alive	262	274	246	265	287
Number recaptured dead	53	24	37	29	0
Number assigned dead <sup>(a)</sup>	5	6	13	4	2
Number undetermined	0	0	2	0	1
<b>48-hour survival</b>	<b>0.674</b>	<b>0.840</b>	<b>0.636</b>	<b>0.806</b>	
SE	0.027	0.023	0.029	0.025	
95% CI (±)	0.054	0.045	0.057	0.048	
Significance	significant ( $P < 0.01$ )		significant ( $P < 0.01$ )		
Number examined for maladies	315	298	283	294	287
Number without maladies	149	153	107	161	286
Number with maladies	166	145	176	133	1
<b>Malady-free rate</b>	<b>0.475</b>	<b>0.515</b>	<b>0.379</b>	<b>0.550</b>	
SE	0.028	0.029	0.029	0.029	
95% CI (±)	0.055	0.057	0.057	0.057	
Significance	non-significant ( $P > 0.05$ )		significant ( $P < 0.01$ )		

(a) Includes dislodged tags and stationary signals.

**Table 3.12.** Survival and malady-free rates (with 95% confidence intervals [CIs]) for rainbow trout passage through the turbine at Detroit Dam, October 2009 (Normandeau 2010).

Passage Location	Turbine Unit 2	Controls
Number released	170	50
Number recaptured alive	100	50
Number recaptured dead	38	0
Number assigned dead <sup>(a)</sup>	32	0
Number undetermined	0	0
<b>48-hour survival</b>	<b>0.541</b>	
SE	0.038	
95% CI (±)	0.074	
Number examined for maladies	138	50
Number without maladies	71	50
Number with maladies	67	0
<b>Malady-free rate</b>	<b>0.515</b>	
SE	0.043	
95% CI (±)	0.084	

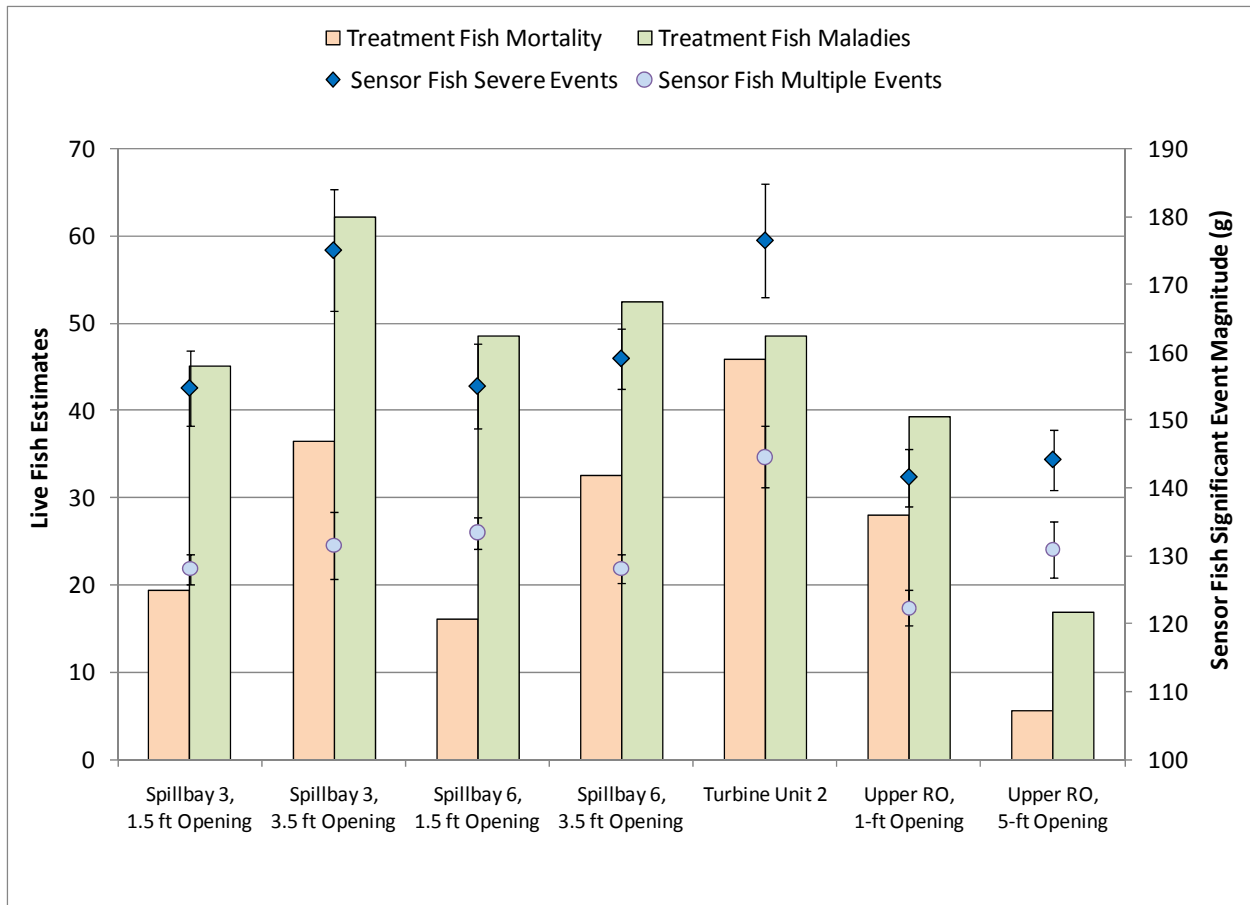
(a) Includes dislodged tags and stationary signals.

**Table 3.13.** Survival and malady-free rates (with 95% confidence intervals [CIs]) for rainbow trout passage through the regulating outlet at Detroit Dam, December 2009 (Normandeau 2010).

Passage Location	Regulating Outlet		Controls
	Deep		
<b>Gate opening</b>	<b>1.0</b>	<b>5.0</b>	
Number released	165	145	90
Number recaptured alive	122	140	90
Number recaptured dead	28	3	0
Number assigned dead <sup>(a)</sup>	14	1	0
Number undetermined	1	1	0
<b>48-hour survival</b>	<b>0.720</b>	<b>0.972</b>	
SE	0.034	0.014	
95% CI ( $\pm$ )	0.067	0.027	
Significance	significant ( $P < 0.01$ )		
Number examined for maladies	150	143	90
Number without maladies	91	119	90
Number with maladies	59	24	0
<b>Malady-free rate</b>	<b>0.607</b>	<b>0.832</b>	
SE	0.04	0.031	
95% CI ( $\pm$ )	0.078	0.061	
Significance	significant ( $P < 0.01$ )		

(a) Includes dislodged tags and stationary signals.

Figure 3.6 shows live-fish malady and mortality rates compared to Sensor Fish average significant event magnitudes ( $\pm$  standard error of the mean) for all evaluated passage routes. The reciprocal of the malady-free rate is reported as the injury or malady rate; the reciprocal of survival is reported as mortality. Sensor Fish acceleration magnitudes for spillway treatments showed trends between passage routes and treatments similar to those shown for live-fish mortality and malady estimates. Exposure severity varied by spillbay and gate opening, as shown by the magnitudes of significant events and the proportion of sensors showing multiple events. Both the live-fish and Sensor Fish data indicated that passage conditions were worse in spill at higher discharge. The trends between treatments in mean magnitude of significant events and the proportion of test fish experiencing maladies were very similar. A linear model fit to the data indicates that the mean magnitude of the most severe significant events observed during spill passage is a good predictor of malady rate for live fish (Figure 3.7).



**Figure 3.6.** Live-fish mortality and malady estimates contrasted with Sensor Fish significant event magnitudes ( $\pm$  standard error of the mean) for all evaluated passage routes at Detroit Dam.

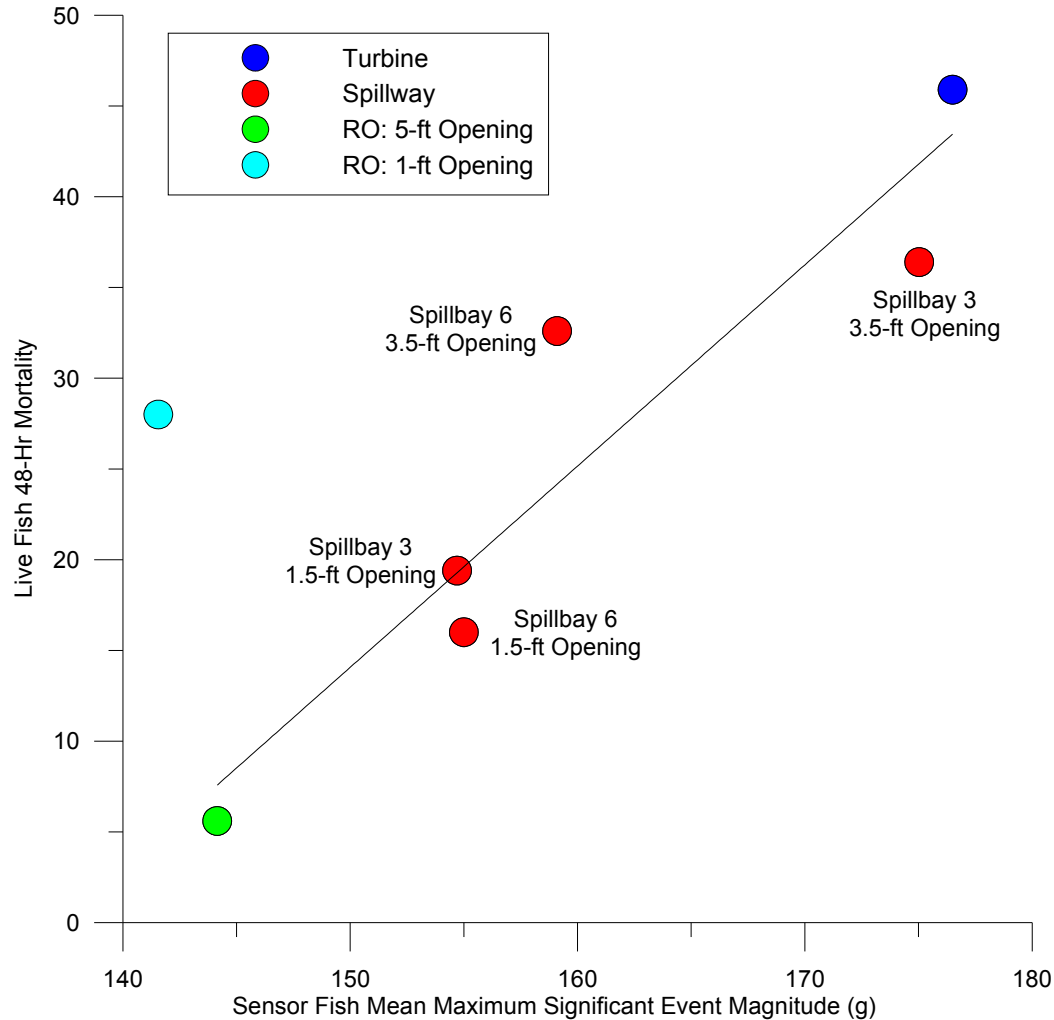
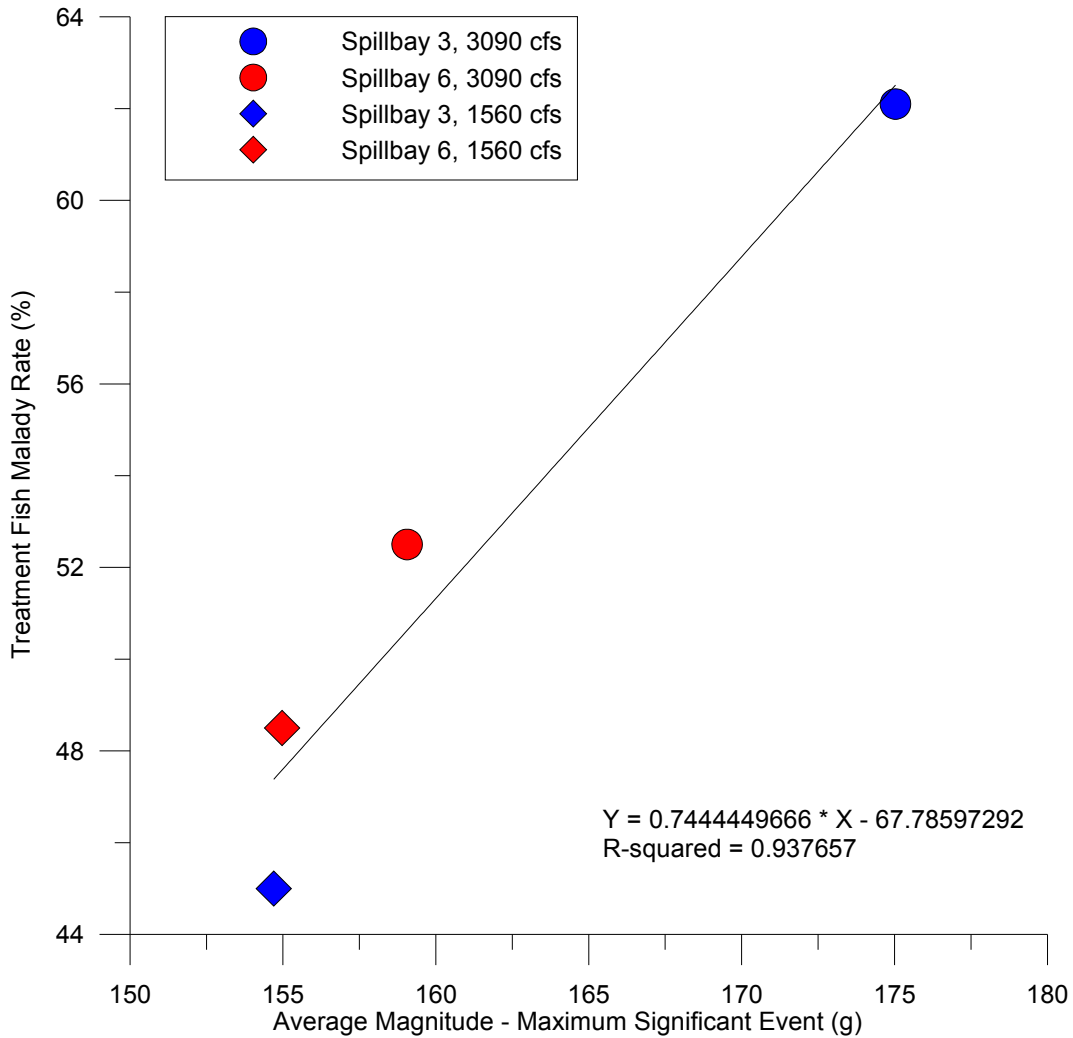


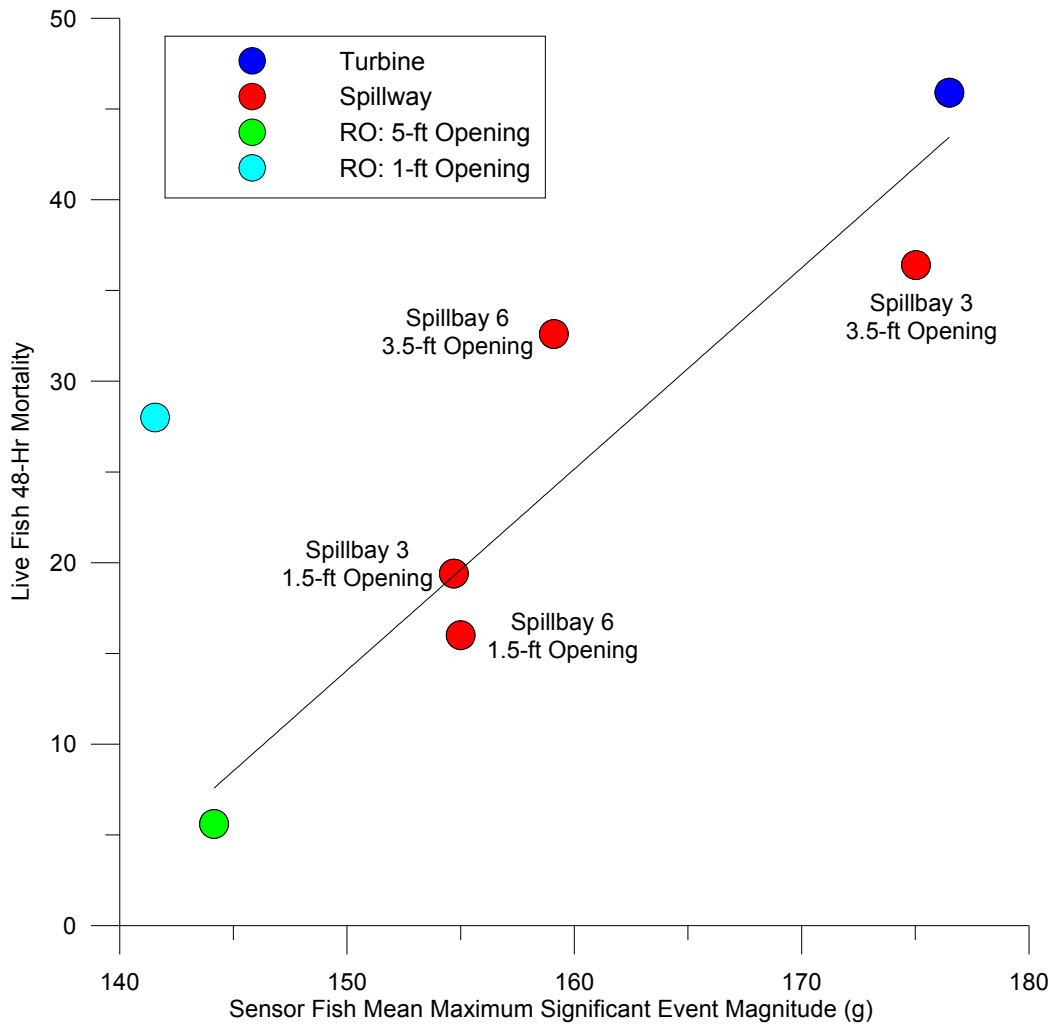
Figure 3.8 shows the relationship between rainbow trout 48-hr mortality and Sensor Fish mean significant event magnitudes for all evaluated passage routes. Simple linear regression analysis indicates a better correlation, with *R*-squared values increasing from 0.511 to 0.888, when excluding the results obtained following passage through the 1-ft RO gate opening. It is very clear that passage conditions as reported from Sensor Fish observations underestimate the severity of passage conditions. Live fish passing the 1-ft gate opening had a higher incidence of major injury, including torn opercula and decapitation. It appears that the Sensor Fish did not respond inertially as did the live fish to the very high acceleration in flow that occurred under the RO control gate when it was open only 1 ft. The probable injury mechanism for the larger juvenile rainbow trout was an impulsive acceleration of water causing the gill covers of fish with their heads pointed downstream to flair. The relative large cross section of the flared gill covers provided a surface for the exertion of an impulsive force strong enough to cause injury to the gills, gill cover, and isthmus. When the force was large enough, the head of the fish was torn from its body. The Sensor Fish because of its shape would not experience any such force, and it is likely that it also did not respond proportionally to the acceleration in flow because of its inertia. Fish passing with

their heads pointed upstream would not be injured, and live fish were introduced to the induction system tail first during the current evaluation (Normandeau 2010). Laboratory studies have demonstrated this phenomenon (Figure 3.9; Guensch et al. 2003).

A linear model fit to the live-fish malady estimates and Sensor Fish turbulence index values for all evaluated passage routes showed that for these passage routes and operating conditions, the Sensor Fish turbulence index is a good predictor of fish malady rate (Figure 3.10).



**Figure 3.7.** Relationship between live-fish estimated malady rate and the average magnitude of the most severe event experienced per release for spillway passage.



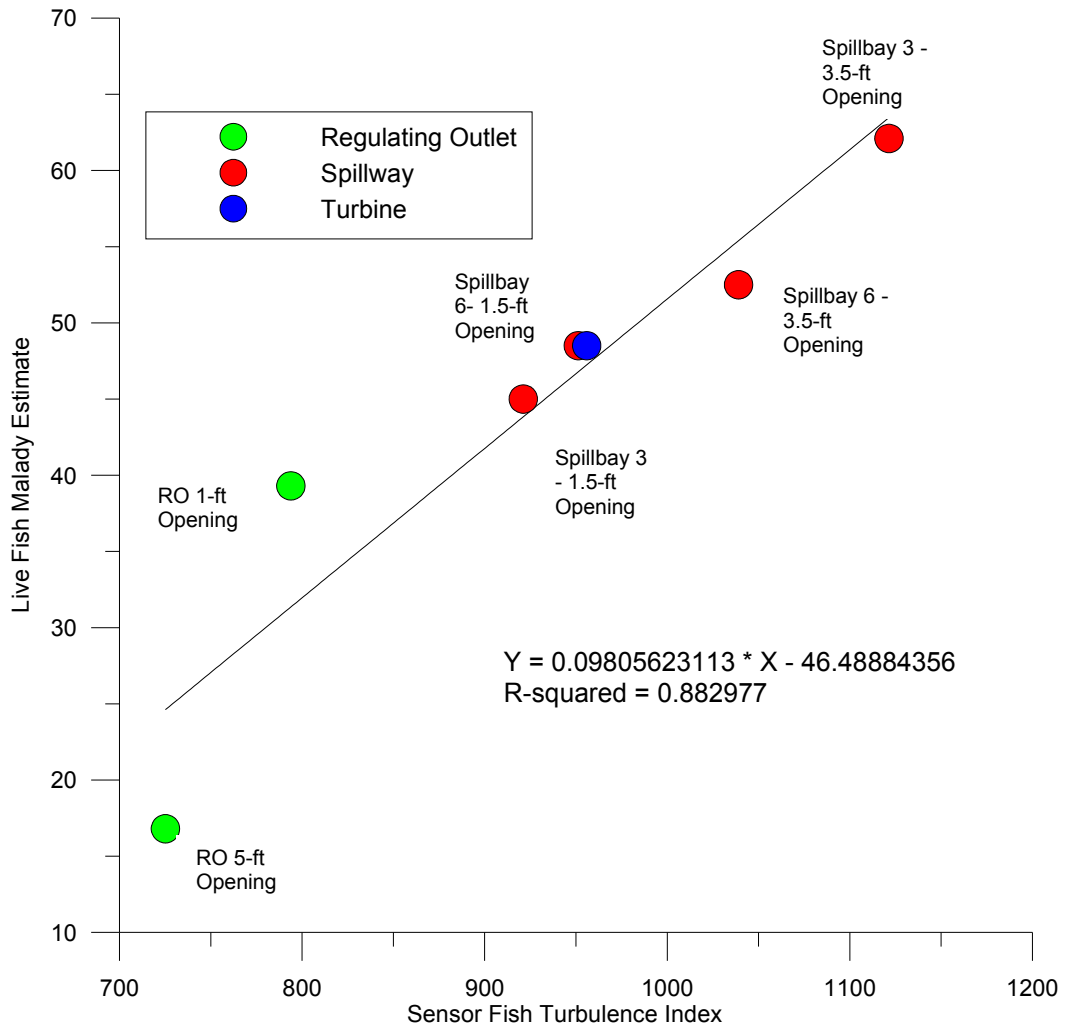
FIT excluding 1-ft RO Opening (Visible Line):  
 $Y = 1.108995181 * X - 152.2839453$   
 R-squared = 0.888356

FIT including 1-ft RO Opening:  
 $Y = 0.7655549809 * X - 94.69063301$   
 R-squared = 0.588466

**Figure 3.8.** Fit of linear model relating live-fish 48-hr mortality rate and the average magnitude of the most severe event experienced per release for all evaluated passage routes at Detroit Dam.



**Figure 3.9.** High speed photograph of a live fish encountering a high-velocity jet, thereby experiencing exposure to high shear. The opercula of the fish have been flared away from their normal position near the body of the fish by the difference between the velocity of the fish and the velocity of the water flowing along the body of the fish.



**Figure 3.10.** Fit of linear model between live-fish estimated malady rate and Sensor Fish turbulence index.



## 4.0 Discussion

The objective of this study was to describe and compare passage exposure conditions through the spillway, penstock/turbine, and regulating outlet at Detroit Dam and to compare Sensor Fish observations of passage conditions with observations of the injuries and mortality and malady rates for live fish. Sensor Fish observations were used to rank the passage routes and operating conditions from best to worst for fish passage. The study proved to be a challenge to Sensor Fish resilience as well as to live-fish survival and injury.

### 4.1 Spillway Passage

Spillbay 3 and Spillbay 6 were evaluated at two spillgate openings. The height and slope of the spillway chute contribute to deleterious exposure conditions observed during the study. Detroit Dam, completed in 1953, is slowly deteriorating due to age. The concrete surface of the spillway is rough from weathering (Figure 4.1), and the descending flow is irregular (Figure 4.2)—conditions that probably incrementally worsened spillway passage conditions.



**Figure 4.1.** Spillbay 3 at Detroit Dam showing the rough, irregular concrete surface.

In Spillbay 3, the unconfined spillway discharge spread rapidly once past the structure supporting the tainter gate hinge assemblies (Figure 4.3). In contrast, Spillbay 6 was confined from the tainter gate through stilling basin entry (Figure 4.2). Spillway flow velocities were estimated to exceed 150 fps before plunging into the stilling basin. Sensor Fish were often carried to depths of over 30 ft with spillway discharge, at times striking rocks or other unidentified objects as they were carried in turbulent flow through the stilling basin.



**Figure 4.2.** Spillbay 6, 3.5-ft gate opening (3090 cfs), showing walls confining the turbulent flow created on the rough spillway chute.



**Figure 4.3.** Flow through Spillbay 3, 1.5-ft gate opening (1560 cfs discharge) spreads to adjoining spillbays.

The highest turbulence, highest rates of collision, and the most energetic collisions were observed at higher spillway discharge, and these measures were very similar for both spillways in spite of considerable difference in structure and flow conditions with distance down the spillway chutes. Typically, as spill discharge increases, the conditions for fish passage improve. In the case of these spillways, it appears that the very turbulent flow down the spillway chute at higher discharge greatly increases the frequency of occurrence and force of collisions.

Almost all Sensor Fish experienced a collision on the spillway chute shortly after passage under the spillway tainter gate. Probably because of much less submergence and greater velocity during gate passage, the momentum of the Sensor Fish carried it a farther distance down the spillway chute prior to collision when the tainter gate opening was 1.5 ft (Figure 4.4). At the higher discharge when the tainter gate opening was 3.5 ft, it appears the Sensor Fish were traveling at a lower velocity and deeply enough entrained in discharge flow to be carried to a point of initial contact with the spillway surface upstream of that typical at the lesser discharge.

It would seem that considerably higher discharge than that tested would be required to provide a depth of flow sufficient to reduce the probability of collision during spillway transit. However, it is likely that such a discharge would result in stilling basin conditions that would be very highly turbulent and would also result in higher probabilities of contact with structure in the stilling basin.

Several Sensor Fish recovered following passage through the spillway were noticeably damaged, with deep scratches and portions of the polycarbonate shell chipped away (Figure 4.5). Extreme forces are needed to fragment polycarbonate, a highly impact-resistant, low-scratch durable polymeric plastic. Although the Sensor Fish have been scratched and scraped during previous studies on the Columbia and Snake rivers, the damage observed on the casing following passage in spill at Detroit Dam was much worse.

Sensor Fish observations indicate that flow quality was inferior and the magnitudes of collision and shear events more severe compared to those observed at Columbia and Snake river dams. Data from Sensor Fish following passage through the 3.5-ft tainter gate opening at both Spillway 3 and Spillway 6 indicated these sensors incurred the highest significant event magnitudes—an average value of 175 g at Spillbay 3 and 159.1 g at Spillway 6 for the most severe events. Data obtained following passage through the 1.5-ft opening were nearly equivalent—154.73 g and 154.97 g for Spillbay 3 and Spillbay 6, respectively. Taking multiple events into account, mean values were 131.34 g, 131.05 g, 129.35 g, and 129.02 g for Spillbay 3 (3.5-ft gate opening), Spillbay 6 (3.5-ft gate opening), Spillbay 3 (1.5-ft gate opening), and Spillbay 6 (1.5-ft gate opening), respectively.

Live-fish survival and malady estimates follow similar trends—estimates for 48-hr mortality are 36.4, 32.6, 19.4, and 16% for Spillbay 3 (3.5-ft gate opening), Spillbay 6 (3.5-ft gate opening), Spillbay 3 (1.5-ft gate opening), and Spillbay 6 (1.5-ft gate opening), respectively. Estimates for maladies are 62.1, 52.5, 48.5, and 45.1% for Spillbay 3 (3.5-ft gate opening), Spillbay 6 (3.5-ft gate opening), Spillbay 6 (1.5-ft gate opening), and Spillbay 3 (1.5-ft gate opening), respectively. Sensor Fish turbulence index values follow trends similar to those observed for live-fish estimated maladies and observed Sensor Fish acceleration magnitudes.



**Figure 4.4.** A hydraulic jump carries the Sensor Fish down the spillway chute as flow passes under the tainter gate in Spillbay 3 with the gate open 1.5 ft (1560 cfs discharge).



**Figure 4.5.** Chips and scratches visible on the polycarbonate Sensor Fish casing.

The influence of elevation of entry into spillway approach flow using Sensor Fish and live fish has been evaluated at several Columbia and Snake river dams (Carlson and Duncan 2004, 2009; Carlson et al. 2006, 2008b; Normandeau 2004, 2006; Normandeau and Skalski 2005, 2006a, 2006b; Normandeau et al. 2008). These studies indicate that elevation of entry influences the frequency of occurrence, location of occurrence, and type of significant event for Sensor Fish. They also show that elevation of entry influences the survival and injury rates of HI-Z-tagged juvenile Chinook salmon. Sensor Fish and HI-Z-tagged fish entering spill approach flow at deeper depths (lower elevations) have been found to have a higher probability of exposure to injurious or fatal events and higher exposure severity. The implication is that Sensor Fish and live fish that enter approach flow at lower elevations are nearer the spillway structure during spillway passage and are therefore more likely to experience collisions.

The USACE designed the current study to evaluate passage at target Sensor Fish and live test fish injection elevations upstream of the test spillway's tainter gates approximately 3 ft above the spillway crest for the 3.5-ft tainter gate opening and 3 ft above spillway structure, downstream of the crest for the 1.5-ft tainter gate opening. Computational fluid dynamics modeling was used to determine the target locations, anticipating the injection depth to place the fish and Sensor Fish into flows of approximately 5 fps. Sensor Fish data indicate the target injection elevations were achieved, and there were no significant event occurrences at the pipe exit from either collisions with the injection pipe or shear at entry to spillway approach flow. The premise that Sensor Fish entering approach flow at lower elevations are nearer the spillway structure during spillway passage and experience collisions on structure was validated by frequency of occurrence of collisions observed in this study. The injection location for the 1.5-ft opening caused Sensor Fish and live fish pass under the spillways' tainter gates deeper in discharge flow and nearer the surface of the spillway chute. The result was that 82.1% and 81.4% of the total number of significant events observed for all Sensor Fish spillway releases occurred on the spillway chute for units passing via the 1.5-ft gate openings of Spillbay 3 and Spillbay 6, respectively. The slightly

higher number of events observed on the spillway chute for Spillbay 3 is most likely the result of more rapid decrease in depth of flow relative to that of Spillway 6 because Spillway 3 flow is not confined by guidewalls as it is in Spillway 6.

In a 2006 study of fish passage conditions through spillways at Ice Harbor Dam (Carlson et al. 2008b), Sensor Fish experienced the highest percentage of collisions observed at mainstem Columbia River dam spillways—up to 76%—due most likely to the spillway chute angle of descent (an approximate 55-degree slope) and the deflector at its terminus. Although the Ice Harbor Dam slope is comparable to that of Detroit Dam (53-degree slope), the Ice Harbor drop in elevation is approximately 50 ft while the Detroit Dam descent is more than 300 ft. As a result, spill water velocity at entry into the Detroit Dam stilling basin is more than double the velocity at Ice Harbor Dam. Higher velocity means that the collisions that Sensor Fish and live fish experience on the lower portions of the spillway chute are much more energetic and therefore have more damage potential due to greater momentum, and much more probable due to considerably decreased depth of flow and, in the case of Detroit Dam, highly turbulent flow.

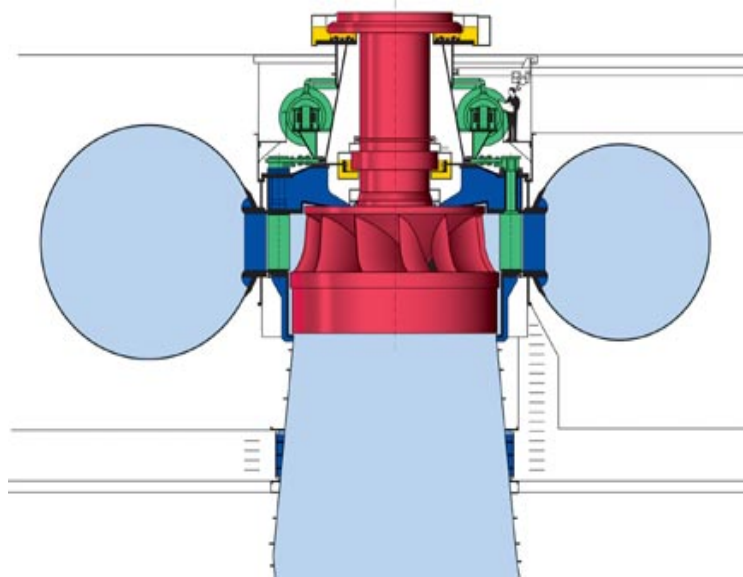
During a 2006 evaluation at Trail Bridge Dam on the McKenzie River in Oregon, more than 85% of the Sensor Fish experienced a significant event during spillway passage; 100% of the Sensor Fish passing through a 0.5-ft gate opening (resulting in flows of approximately 400 cfs) experienced an event (Duncan and Carlson 2007). The spillway at Trail Bridge, approximately 50 ft high and 237 ft long with guidewalls on either side, has a 34% slope. The spillway design differs from those of Ice Harbor and Detroit dams in that it transitions from a width of 30 ft to 20 ft and has a stilling basin “bowl” and a flip lip deflector. Mean significant event magnitudes for the 2006 Ice Harbor study, the Trail Bridge study, and the current evaluation at Detroit Dam were approximately 116 g, 139 g, and 158 g, respectively, for the most severe events per release. For all multiple events, mean magnitudes were 124 g, 126 g, and 130 g for Ice Harbor, Trail Bridge, and Detroit dams, respectively. Clearly, the significant event magnitudes observed at Detroit Dam are the most severe observed for any spillway passage condition study conducted to date.

## 4.2 Penstock/Turbine Passage

Exposure to changes in pressure, shear, turbulence, collisions, strike, cavitation, and grinding may occur during turbine passage and can cause injuries and mortality to fish. Fish are most vulnerable during passage through the wicket gates and runner, where they may collide with structure, be struck by runner blades, be exposed to rapid changes in pressure, and be exposed to turbulence and shear in the wake of wicket gates and runner blades. All Sensor Fish experienced a significant event during runner passage at Detroit Dam; 63% of the most severe significant events observed were due to shear, 37% were strike. A rapid decrease in pressure is not classified as a significant event, given the nomenclature adopted for Sensor Fish data, but is nonetheless one of the primary mechanisms for injury and mortality of turbine-passed fish. Unlike other injury mechanisms, all fish passing through a hydroturbine are exposed to rapid changes in pressure. Exposure to rapid pressure changes will be discussed later.

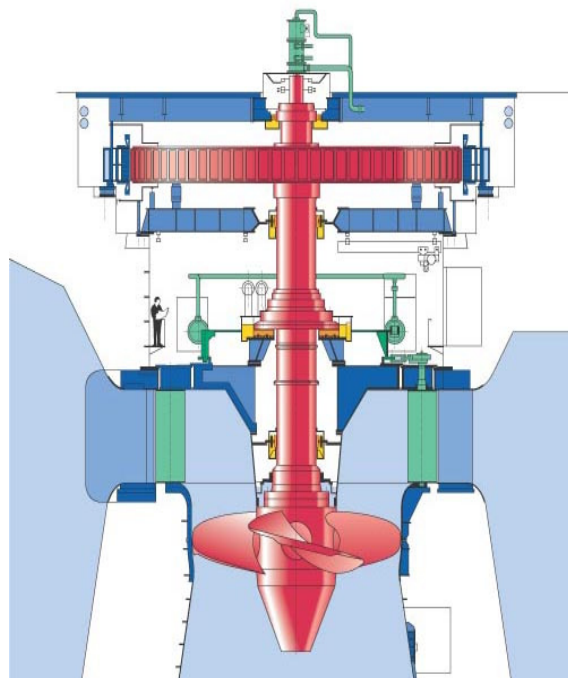
Due to the higher operational heads at Detroit Dam, Francis turbines have been used, in contrast to the low-head Kaplan units operating at Columbia and Snake river dams. Francis turbines are radial flow turbines (Figure 4.6). Water approaches the turbine through a penstock and enters the turbine scroll case. From the scroll case, the water passes through wicket gates, which control the discharge through the

turbine runner. The centerline of the turbine wicket gates and runner entrance are at the same elevation so that water enters at the periphery of the runner blades. The runner is positioned to direct the water axially into the turbine draft tube. Fish that pass into a Francis runner are exposed to the outer edge of the runner blades because all water entering the turbine enters at the outer perimeter of the runner. This portion of the runner blade is at the greatest radial distance from the runner hub and has the highest velocity of any portion of the blades. Thus, all fish are exposed to strike from the highest-velocity portion of the runner blades. This is very different from the situation in Kaplan turbines where the turbine runner lies below the wicket gates so that water enters the turbine runner from above (Figure 4.7). Because of the location of the wicket gates relative to the turbine runner in Kaplan turbines, passing fish are exposed to only the outer periphery of the turbine blades when they pass through the lower portion of the turbine wicket gates. The portion of the runner blade and the velocity of the blade should strike occur, to which fish are exposed when passing through a Kaplan runner are functions of fish elevation of passage through the turbine wicket gates. In addition to blade velocity, Francis turbines typically have a larger number of runner blades than do Kaplan turbines, which influences the probability of strike for passing fish.



**Figure 4.6.** Cross section of a Francis turbine showing the midline of the scroll case (circular chamber shown in blue) and wicket gates (shown in green) at the same elevation as that of the outer edge of the turbine runner blades (shown in red).

The Francis turbine at Detroit Dam operates at 70,000 horsepower and 163.6 revolutions per minute. The runner diameter is 130 in., and the runner opening height is 49.5 in. The velocity of the periphery of the runner is 92.8 fps. Maximum discharge is 5340 cfs, and there are 13 blades and 24 wicket gates. Turbines at Detroit Dam operate almost daily, based on Bonneville Power Administration load demands. During the summer, water depth above the penstocks is approximately 157 ft. Winter drawdown lowers the submergence of the penstock to approximately 47 ft. It appears likely that a variable influencing the probability of entry of fish into Detroit turbines is the submergence depth of the turbine penstock.



**Figure 4.7.** Cross section of a Kaplan turbine showing the wicket gates (shown in green) located above the turbine runner (shown in red in the throat of the turbine downstream of the wicket gates).

Passage conditions through the penstock and turbine Unit 2 operating at approximately 50 MW and discharging approximately 2200 cfs were observed using Sensor Fish. Each penstock at Detroit Dam is approximately 450 ft long, descending approximately 200 ft in elevation to the powerhouse and Francis turbine unit. Sensor Fish passage through the penstock was uneventful—there were no significant magnitude events greater than the threshold value of 95 g, and 84% of the angular rate-of-change magnitudes were less than 1500 degrees/s; all were less than 1700 degrees/s. Penstock flow exhibited low turbulence following convergence after passage through the penstock trash rack. The velocity of flow through the penstock was estimated to be approximately 12 fps at the 2200-cfs discharge.

Pressures observed during passage of the Sensor Fish through the penstock were, as expected, primarily a function of the static pressure of the water plus atmospheric pressure. The velocity of water through the penstock was too low to appreciably affect pressure. During the study, forebay level was approximately 1513 ft MSL and the tailwater was at 1202 ft MSL, resulting in 311 ft of head, which equates to an absolute pressure of approximately 150 psia. The pressure transducer in the current Sensor Fish has a 100-psia limit; however, pressures at locations within the penstock when water velocities are low can be estimated from the elevation of the sensor relative to the forebay water level and atmospheric pressure.

The lowest pressure (nadir) that occurs in the water path from the penstock entrance through draft tube exist occurs on the underside of turbine runner blades, which is called the suction side of the turbine runner. The mean of nadir pressures observed for Sensor Fish passage through the Francis turbine was 6.19 psia; the range in nadir values was 0.93 to 9.93 psia. The observed nadir values for the Detroit Dam Francis turbine are much lower than those observed for mainstem Columbia and Snake river Kaplan turbines. Mainstem Kaplan turbine mean nadir pressures ranged from approximately 14 to 27 psia,



depending upon variables such as discharge and trajectory through the turbine runner (Carlson et al. 2008a; Dauble et al. 2007; Carlson and Duncan 2002).

Using Sensor Fish, the mean rate of change in pressure for the Detroit Dam Francis turbine was  $-1112.5$  psia/s, observed at approach to the nadir. This mean rate of change in pressure was much higher than those observed for passage through Kaplan turbines at mainstem Columbia and Snake river projects, which ranged from  $-125$  to  $-413$  psia/s (Carlson et al. 2008a).

The live balloon-tagged fish released into the spillways, regulating outlet, and turbine at Detroit Dam were not pressure-acclimated. Because of the nature of the balloon-tagging process and handling requirements at placement into injection systems, test fish could not be released in a natural state of neutral buoyancy. Research has clearly shown that physostomous juvenile salmon that are not neutrally buoyant when exposed to rapid decompression do not show the same barotrauma injury and mortality response as fish exposed when in a neutrally buoyant physiological condition (Brown et al. 2009; Carlson et al. 2010). Therefore, any method that cannot ensure acclimation to depth (pressure) prior to exposure to rapid decompression does not test the response of the fish to the change in pressure that all turbine-passed fish experience. We now know that the barotrauma response of juvenile salmon to rapid decompression is a function of species, size, and age, as well as turbine design, operation parameters, and passage location. Given this information, it is clear that the mortality and malady rates reported for live test fish following passage through Detroit Dam Francis turbines underreport the rates that are likely for acclimated fish that pass through these units. A similar concern is warranted for both the spillway and regulating outlet passage, given the rapid changes in pressure observed at control gate passage for these routes. However, for the spillways and regulating outlets, mortality and malady rates attributable to pressure effects would be less than those for the Francis turbine units because the nadir values are approximately atmospheric, 14.7 psia, compared to the much lower nadir values for turbine passage.

### 4.3 Regulating Outlet Passage

Passage conditions for fish through the upper north-side RO was evaluated at two gate openings, 1 ft and 5 ft (Figure 4.8 and Figure 4.9, respectively). The RO discharges into the spillway stilling basin from an opening in the face of the dam at a centerline elevation of 1315 ft MSL in the face of Spillbay 4–5. The velocity of the discharge jet at entry into the stilling basin was estimated to be approximately 90 fps. The RO discharge jet is rapidly entrained in the stilling basin, creating conditions that expose the Sensor Fish and live fish to shear. Overall, approximately 70% of Sensor Fish experienced a significant shear event at entry into the stilling basin. Approximately 82% of Sensor Fish releases showed a significant shear event when the control gate was open 1 ft and 58% when the control gate was open 5 ft.

Computational fluid dynamics modeling of flow through the RO conduit when the control gate was open 5 ft is shown in Figure 4.10. At this gate setting, RO discharge was approximately 1900 cfs when the forebay elevation was 1450 ft MSL. The mean forebay elevation for the study was approximately 1441 ft MSL, which corresponds to a discharge of approximately 1800 cfs at a 5-ft control gate opening. The CFD model estimates flow velocity at 18 fps at the entrance to the RO for the 5-ft gate opening. The flow rapidly accelerates to more than 30 fps a short distance into the RO conduit.



**Figure 4.8.** Regulating outlet discharge at Detroit Dam when the control gate was open 1 ft.



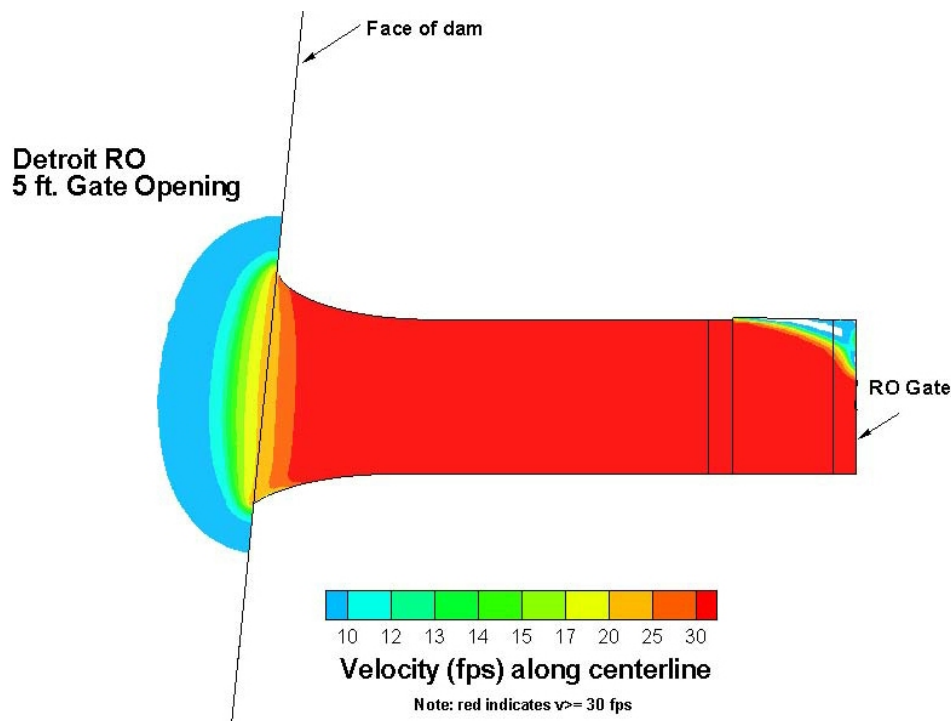
**Figure 4.9.** Regulating outlet discharge at Detroit Dam when the control gate was open 5 ft.

After passage under the control gate, RO discharge accelerates to approximately 45 fps and is relatively uniform laterally and vertically (Phillips 2010<sup>1</sup>). (A slight decrease in flow velocities may be assumed for the study period, due to the lower forebay elevation [1441 ft MSL] compared to the forebay elevation used for CFD modeling [1450 ft MSL].) No collision or shear events were observed at injection of Sensor Fish into RO intake flow. In addition, the quality of flow was good upstream of the control gate in the RO conduit at the 5-ft control gate opening. Although there were no significant events at

---

<sup>1</sup>Phillips M. 2010. Memorandum from M Phillips (CENWP-EC-HD) to D Griffith and T Kuhn (CENWP-PM-E), "Detroit Dam Direct Mortality Studies – Velocity Analysis for Preferred Release Locations for Regulating Outlet and Turbine Penstock," May 14, 2010, Portland, Oregon.

injection, Sensor Fish data showed a slight drop in pressure immediately following passage into RO flow, most likely the effect of slip velocity on the Sensor Fish pressure transducer. The pressure decrease was minor and also an artifact of the Sensor Fish measurement process and not a physical factor that would be a risk to fish health. Figure 4.11 Sensor Fish release pressure time histories for passage through the RO when the control gate was open 1 ft and 5 ft. The velocity of water through the RO conduit upstream of the control gate for the two gate settings and consequent discharges (approximately 30 fps with a discharge of 1900 cfs and 8 fps with a discharge of 500 cfs for the 5-ft and 1-ft openings, respectively) are evident in Sensor Fish travel times from injection to control gate passage, a distance of approximately 40 ft. These travel times were approximately 1.2 and 4.5 s for the 5-ft and 1-ft control gate openings, respectively.

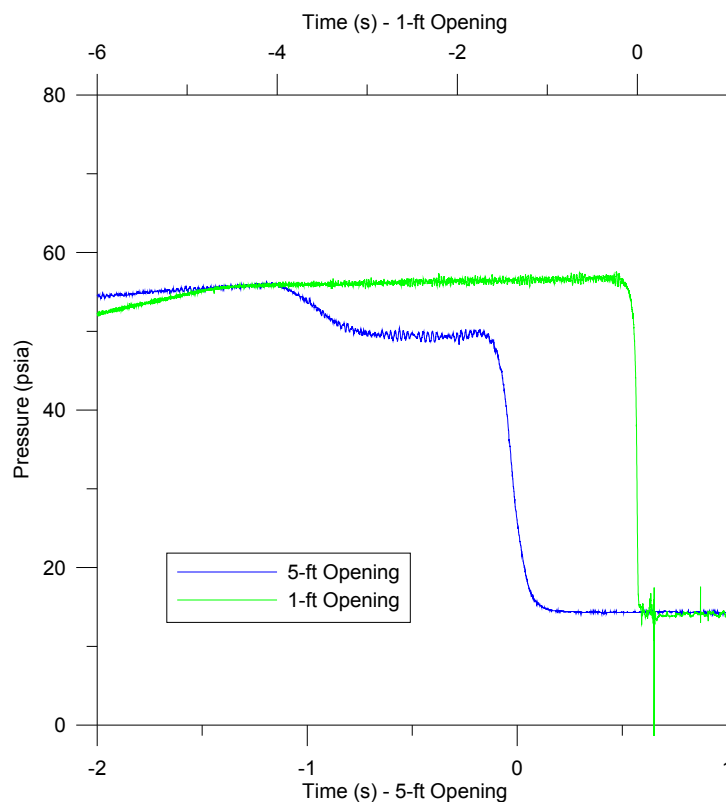


**Figure 4.10.** Computational fluid dynamics estimate of water velocity through the RO when the control gate was open 5 ft (Phillips 2010<sup>1</sup>).

Computational fluid dynamics estimates of water velocity through the RO conduit when the control gate was open 1 ft are shown in Figure 4.12. In contrast with that for the 5-ft gate opening, there is a significant increase in water velocity from 10 to 30 fps immediately upstream of the control gate. The average acceleration magnitude of the Sensor Fish during passage under the control gate at an opening of 1 ft was nearly 4 times that observed during passage when the gate was open 5 ft. During passage under the 1-ft open gate, flow becomes supercritical; depth of flow decreases as water velocity increases. There is a rapid decrease in pressure from that in the conduit to atmospheric in the partially filled conduit downstream of the control gate. Immediately after gate passage, there is a hydraulic jump in the flow, followed by a reduction in water velocity, as the flow becomes subcritical and exits the RO conduit into

<sup>1</sup> Phillips M. 2010. Memorandum from M Phillips (CENWP-EC-HD) to D Griffith and T Kuhn (CENWP-PM-E), "Detroit Dam Direct Mortality Studies – Velocity Analysis for Preferred Release Locations for Regulating Outlet and Turbine Penstock," May 14, 2010, Portland, Oregon.

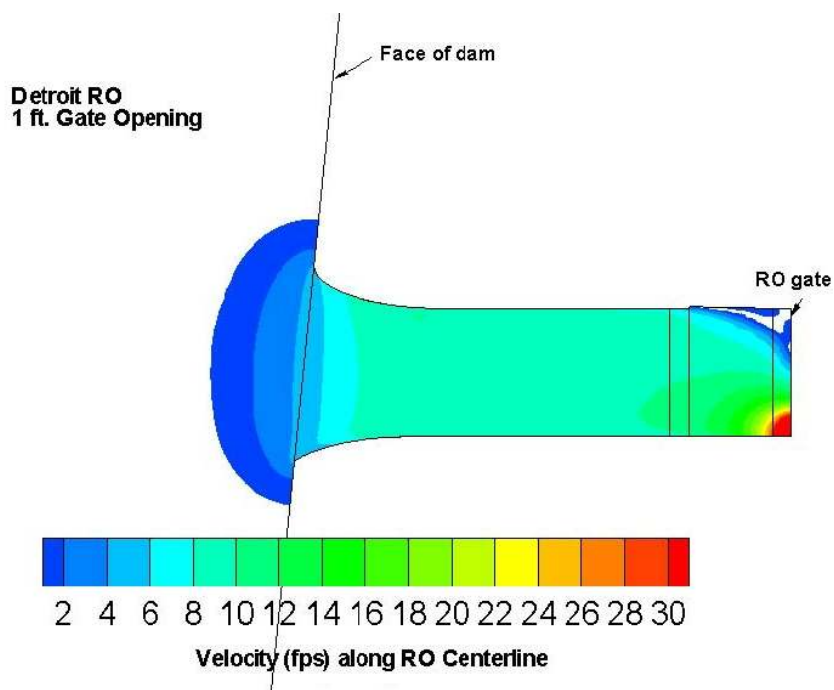
the spillway stilling basin. The turbulent flow combined with the shallow depth of flow immediately downstream of the control gate were probably the main factors that contributed to the high rate of Sensor Fish collisions observed in this region. Approximately 71% of the Sensor Fish that passed through the RO when the control gate was open 1 ft experienced a collision event immediately following gate passage. No similar collision events were observed for any of the Sensor Fish that passed through the RO when the control gate was open 5 ft.



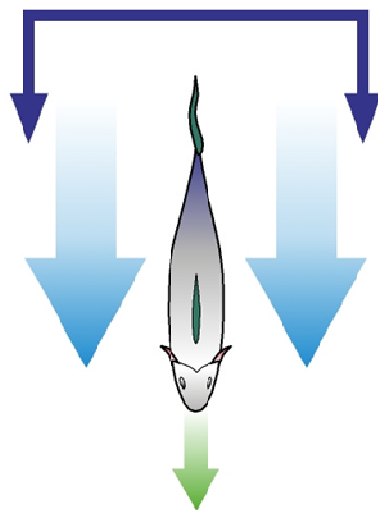
**Figure 4.11.** Sensor Fish pressure time histories for passage through the RO from injection through passage under the RO control gate for control gate settings of 1 ft and 5 ft.

Although only one significant shear event was observed during Sensor Fish passage under the RO control gate when it was open 1 ft, a high rate of serious injury such as torn opercula and mortality by decapitation were observed for live fish passing under the same conditions (Normandeau 2010). Research has shown that the size of fish entrained in rapidly accelerating flow is a factor in their risk of injury. Because of their greater inertia, larger fish do not accelerate with the flow and are exposed to injury from water moving at a higher velocity than their body (see Figure 4.13 and Figure 4.14). The risk of injury is greatest for fish that have their heads pointed downstream. In this position, the opercula of the fish are raised and may be at an angle of almost 90 degrees to the body of the fish. The attitude of the opercula presents a large cross section that can be acted on by the force of the higher-velocity water passing around the fish. Laboratory studies have shown that the resulting force is strong enough to cause severe damage to the fish's opercula, gills, and isthmus. Tears to the isthmus can be severe, and decapitation is a likely outcome. Fish that are oriented into the flow are at a significantly lower risk of injury, the exception being damage to their eyes (Guensch et al. 2003). During the current study, live fish were placed tail-first into the injection system. Fish averaged 7.3 in. in length (ranging from 4.8 to

8.6 in.). Dependent on the elevation of passage prior to the gate, forces from rapid acceleration at the 1-ft opening may have drawn the fish tail first under the gate, catching or striking the head region on the gate. Bruising and scraping were observed on 13% of the fish, and 9% were decapitated or nearly decapitated following passage through the RO at the 1-ft gate opening (Normandeau 2010).

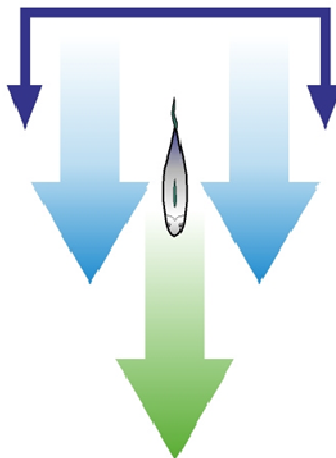


**Figure 4.12.** Computational fluid dynamics estimate of water velocity through the RO when the control gate was open 1 ft (Phillips 2010<sup>1</sup>).



**Figure 4.13.** Large fish entrained within the force of rapidly accelerating water are exposed to injury from water moving at a higher velocity than their body.

<sup>1</sup> Phillips M. 2010. Memorandum from M Phillips (CENWP-EC-HD) to D Griffith and T Kuhn (CENWP-PM-E), “Detroit Dam Direct Mortality Studies – Velocity Analysis for Preferred Release Locations for Regulating Outlet and Turbine Penstock,” May 14, 2010, Portland, Oregon.



**Figure 4.14.** Small fish, with less inertia, are carried with the force of rapidly accelerating water surrounding their body.

The inertia of the Sensor Fish likely was small enough that the sensor was accelerated with the water passing under the RO control gate at both the 1-ft and 5-ft openings. As such, the Sensor Fish was not able to detect the conditions that resulted in the serious injury and mortality of the live test fish. This also makes the point that the injury types and rates of occurrence, in addition to the rates of mortality, are a function of fish size, and the results for one size group of fish cannot be extrapolated to another, particularly when the sizes of the fish differ significantly.

The pressure reported by Sensor Fish decreased rapidly to near atmospheric following passage under the RO control gate for both the 1-ft and 5-ft openings. However, the rate at which this change in pressure occurred differed by a large amount between the two gate openings. The pressure rate of change was approximately 3.5 times greater ( $-944.5$  psia/s) for the 1-ft gate opening than for the 5-ft gate opening ( $-272.1$  psia/s). Such differences are a reflection of the differences in acceleration of flow under the control gate for the two openings. As mentioned before, the live fish used to test the risk of RO passage conditions to fish health were not pressure-acclimated prior to injection. Given the magnitude and rates of change in pressure at RO passage, it is likely the observed injury and mortality rates for fish are underestimated.

The magnitude and rate of change in pressure and associated magnitude of acceleration in flow during control gate passage are functions of operational head. During the RO study, head was approximately 239 ft, which is typical of conditions during winter drawdown of the dam reservoir. During the spring and summer, when the dam reservoir would be nearly full, the RO operating head could be as high as 375 ft. It is likely that fish passage conditions would deteriorate at all gate openings, particularly small gate openings, over those observed in this study as RO operating head increases.

#### 4.4 All Passage Routes

None of the passage routes tested during this study can be considered safe for fish passage. The spillway route was most destructive, with damage to more than 16% of the Sensor Fish; the RO was least damaging (2.6%). Passage through the turbine resulted in damage to more than 13% of the sensors, evidenced by circuit board fragments visible within the polycarbonate casing.

Survival and injury estimates from the live-fish evaluations conducted concurrently with the Sensor Fish tests generally agree with the data obtained from Sensor Fish releases. Acceleration magnitudes observed for turbine passage were the highest observed for hydropower passage routes to date, as were pressure rate-of-change values; nadir pressures were lowest. The estimated 48-hr mortality rates and significant event acceleration magnitudes showed a strong similarity in trends. This extended to turbine passage where the highest Sensor Fish significant event magnitudes and live fish mortality rates were also similar.

Sensor Fish and live-fish data indicate that the RO provided the best fish passage conditions of the routes tested. Differences in Sensor Fish significant event magnitude observations were small for the 1-ft and 5-ft control gate openings. However, large differences between passage conditions at the two gate openings were observed for water acceleration magnitudes and pressure rates of change; for these data components, the values for the 1-ft control gate opening were nearly 4 times those observed for the 5-ft gate opening. In addition, there was a much greater likelihood of multiple significant events occurring during passage through the 1-ft gate opening. The inertia of the fish used to evaluate RO passage conditions and fish length in relation to the dimension of the gate opening are hypothesized to be factors in the high rates of injury and mortality by decapitation observed. It is unlikely that the Sensor Fish detected these conditions.

The spillway evaluation was conducted during the summer when head was greatest (359 ft). The RO and turbine evaluations were done in the fall and winter with heads of 311 ft and 239 ft, respectively. The results reported here are for these conditions; similar studies at different operating heads would likely produce differing outcomes.

## 5.0 Conclusions

Exposure conditions observed from Sensor Fish time histories following passage through Detroit Dam spillways in July 2009 indicate conditions are unfavorable to the health and survival of both live fish and Sensor Fish. Over the course of the study, nearly 100% of the Sensor Fish experienced at least one significant acceleration magnitude event; the majority of events were collisions on the spillway chutes. The observed percentage and number of collisions are much greater than those observed in previous investigations of passage through spillways at mainstem Columbia and Snake river dams. Shear events during the evaluation were infrequent (4%) but were observed in all regions of spillway passage; the majority occurred following passage through the 3.5-ft tainter gate opening. Flow quality as computed using the Sensor Fish turbulence index was best for passage through Spillbay 3 at the 1.5-ft gate opening. The poorest flow quality was observed for Spillbay 3 at the 3.5-ft gate opening.

Both significant event and turbulence index observations indicate that passage through Spillway 3 at a 3.5-ft tainter gate opening is the most detrimental to fish passing the project.

Exposure conditions for passage through the turbine proved particularly hazardous to both live fish and Sensor Fish. All Sensor Fish released into the turbine experienced at least one significant collision or shear event, and 95% experienced multiple events. There was an average of 3.5 significant events per Sensor Fish release, and 13% of the Sensor Fish released were physically damaged during turbine passage. The forces acting on Sensor Fish damaged during turbine passage were severe enough to shatter printed circuit cards, leaving pieces scattered within the polycarbonate case as well as visible infiltrated water. It is likely this damage was caused by turbine runner blades striking the sensors.

All of the most severe events experienced by Sensor Fish (based on acceleration magnitude data) occurred in the runner region; the mean value for these events was 176.5 g, the highest values observed to date, with maximum values as high as 234 g. Sixty-three percent of the primary events observed were due to shear; 37% were strikes or collisions. Magnitudes were highest for the shear events (mean value = 184.5 g). Taking into consideration multiple events, 97% occurred in the runner region; one event was observed prior to the runner and one in the draft tube region. The observed events were most likely blade strike and exposure to shear and turbulence in the wake of wicket gates and turbine runner blades.

Mean pressure nadir values obtained during turbine runner passage at Detroit Dam were the lowest observed to date using Sensor Fish, less than half the magnitude of those observed at Columbia and Snake river dams. Related pressure rate-of-change was over 2 times greater than that observed for the large Kaplan turbines at mainstem dams.

Results from Sensor Fish data for RO passage at Detroit Dam indicate the 1-ft gate opening produced more severe conditions for fish passage. All Sensor Fish passing via the 1-ft gate opening experienced at least one significant collision or shear event, and 94% were subjected to multiple events. Eleven percent of the Sensor Fish passing through the 5-ft gate opening had no significant event; 47% had a single event, and 42% experienced multiple events. On average, there were 3 events per release for Sensor Fish passage through the 1-ft gate opening and 1.53 events per release for the 5-ft opening. One Sensor Fish was damaged during passage at the 1-ft gate opening.



The most severe significant event was observed during the plunge of a Sensor Fish into the stilling basin following RO passage. Ninety percent of the significant events observed during entry of the RO discharge into the spillway stilling basin were shear. The mean acceleration magnitudes for significant events observed during entry of RO discharge into the spillway stilling basin were 135.9 g and 136.6 g for the 1-ft and 5-ft gate openings, respectively. Sixty-five percent of the most severe events observed following passage through the 1-ft gate opening occurred during the plunge; 53% of the most severe events observed following passage through the 5-ft gate opening occurred in the same region.

It is clear from both the Sensor Fish and live-fish study results that passage conditions through the RO when the control gate is open 1 ft are detrimental for fish. The rapid increase in water velocity under the RO control gate when it was open 1 ft created conditions that contributed to decapitation of 9.3% of the fish. None of the live fish passing through the 5-ft gate opening were decapitated (Normandeau 2010). Water velocity acceleration magnitudes under the RO control gate at the 1-ft opening were nearly 4 times greater than those observed when the gate was open 5-ft. Rapid decompression was observed following passage under the RO gate, with pressure rates of change 3.5 times greater for 1-ft gate passage than for 5-ft passage.

Results from the Sensor Fish and live fish passage evaluations at Detroit Dam would likely be different with changes in dam operations, or for the same operations but with forebay elevations different from those tested. The effect of higher operating heads on changes in magnitudes and rates of change in pressure would likely contribute to greater mortality and injury rates. Because test fish used during the Detroit Dam passage evaluations were not acclimated (i.e., not neutrally buoyant) to pressure, it is very likely the malady and mortality rates observed are underestimated, particularly for turbine passage. Sensor Fish and live fish study results indicate that the RO passage route with a control gate opening of 5 ft was the safest route for fish passage of the routes and operating conditions tested. Turbine and spillway passage were the most deleterious.

## 6.0 References

- Brown RS, TJ Carlson, AE Welch, JR Stephenson, CS Abernethy, CA McKinstry, and MH Theriault. 2007. *Assessment of Barotrauma from Rapid Decompression of Depth-Acclimated Juvenile Chinook Salmon Bearing Radiotelemetry Transmitters*. PNNL-16790, Pacific Northwest National Laboratory, Richland, Washington.
- Brown RS, TJ Carlson, AE Welch, JR Stephenson, CS Abernethy, BD Ebberts, MJ Langeslay, ML Ahmann, DH Feil, JR Skalski, and RL Townsend. 2009. "Assessment of Barotrauma from Rapid Decompression of Depth-Acclimated Juvenile Chinook Salmon Bearing Radiotelemetry Transmitters." *Transactions of the American Fisheries Society* 138:1285–1301.
- Carlson TJ and JP Duncan. 2002. *Characterization of the McNary Dam Turbine Fish Passage Environment, April 2002*. PNWD-3310, Battelle–Pacific Northwest Division, Richland, Washington.
- Carlson TJ and JP Duncan. 2004. *Characterization of Spillway Passage Conditions at Ice Harbor Dam, Snake River, Washington, 2003*. PNWD-3462, Battelle–Pacific Northwest Division, Richland, Washington.
- Carlson TJ and JP Duncan. 2009. *Evaluation of Fish Passage Conditions for a Top Spillway Weir at John Day Dam Using the Sensor Fish*. PNWD-4023, Battelle–Pacific Northwest Division, Richland, Washington.
- Carlson TJ, JP Duncan, MC Richmond, JA Serkowski, and Z Deng. 2006. *Characterization of Spillway Passage Conditions at Lower Monumental Dam, Snake River, Washington, 2005*. PNWD-3662, Battelle–Pacific Northwest Division, Richland, Washington.
- Carlson TJ, JP Duncan, and Z Deng. 2008a. *Data Overview for Sensor Fish Samples Acquired at Ice Harbor, John Day, and Bonneville II Dams in 2005, 2006, and 2007*. PNNL-17398, Pacific Northwest National Laboratory, Richland, Washington.
- Carlson TJ, JP Duncan, and Z Deng. 2008b. *Sensor Fish Characterization of Spillway Conditions at Ice Harbor Dam in 2004, 2005, and 2006*. PNWD-3839, Battelle–Pacific Northwest Division, Richland, Washington.
- Carlson TJ, RS Brown, JR Stephenson, AJ Gingerich, BD Pflugrath, AHA Colotelo, AE Welch, PL Benjamin, JR Skalski, A Seaburg, and RL Townsend. 2010. *Assessment of Barotrauma in Untagged and Tagged Juvenile Chinook Salmon Exposed to Simulated Hydro-Turbine Passage*. PNNL-19625, Pacific Northwest National Laboratory, Richland, Washington.
- Dauble, DD, Z Deng, MC Richmond, RA Moursund, TJ Carlson, CL Rakowski, and JP Duncan. 2007. *Biological Assessment of the Advanced Turbine Design at Wanapum Dam, 2005*. PNNL-16682, Pacific Northwest National Laboratory, Richland, Washington.
- Deng Z, TJ Carlson, JP Duncan, and MC Richmond. 2007a. "Applications of the Sensor Fish Technology." *Hydro Review* 26(5):34–41.

Deng Z, TJ Carlson, JP Duncan, and MC Richmond. 2007b. "Six-degree-of-freedom Sensor Fish Design and Instrumentation." *Sensors* 7(12):3399–3415.

Duncan JP. 2010. *Evaluation of Fish Passage Conditions for Juvenile Salmonids Using Sensor Fish at Detroit Dam, Oregon*. PNNL-18747, Pacific Northwest National Laboratory, Richland, Washington.

Duncan JP and TJ Carlson. 2007. *Sensor Fish Characterization of Spillway Conditions at Trail Bridge Dam, McKenzie River, Oregon 2006*. PNWD-3798, Battelle–Pacific Northwest Division, Richland, Washington.

Guensch GR, RP Mueller, CA McKinstry, and DD Dauble. 2003. *Evaluation of Fish-Injury Mechanisms During Exposure to a High-Velocity Jet*. PNNL-14173, Pacific Northwest National Laboratory, Richland, Washington.

Heisey PG, D Mathur, and T Rineer. 1992. "A Reliable Tag-Recapture Technique for Estimating Turbine Passage Survival: Application to Young-of-the-Year American Shad (*Alosa sapidissima*)."  
*Canadian Journal of Fisheries and Aquatic Sciences* 49:1826–1834.

NMFS. 2008. *2008 Willamette Project Biological Opinion*. National Marine Fisheries Service, Seattle, Washington.

Normandeau Associates, Inc. 2004. *Juvenile Salmonid Direct Survival/Injury in Passage through the Ice Harbor Dam Spillway, Snake River*. Report prepared for the U.S. Army Corps of Engineers, Walla Walla District, Walla Walla, Washington.

Normandeau Associates, Inc. 2006. *Direct Survival and Injury of Juvenile Salmon Passing Ice Harbor Spillway under Plunging, Skimming, and Undular Tailwater Conditions*. Report prepared for the U.S. Army Corps of Engineers, Walla Walla District, Walla Walla, Washington.

Normandeau Associates, Inc. 2010. *Estimates of Direct Survival and Injury of Juvenile Rainbow Trout (Oncorhynchus mykiss) Passing Spillway, Turbine, and Regulating Outlet at Detroit Dam, Oregon*. Draft Report prepared for the U.S. Army Corps of Engineers, Portland District – Willamette Valley Project, Portland, Oregon.

Normandeau Associates, Inc. and JR Skalski. 2005. *Effects of Differential Spill Volume and Entrainment Depth on Survival and Injury of Juvenile Salmonids at the Ice Harbor Dam Spillway, Snake River*. Report prepared for the U.S. Army Corps of Engineers, Walla Walla District, Walla Walla, Washington.

Normandeau Associates, Inc. and JR Skalski. 2006a. *Comparative Assessment of Spillbay Passage Fish Condition and Survival for Installation of a Removable Spillway Weir at Lower Monumental Dam, Snake River*. Report prepared for the U.S. Army Corps of Engineers, Walla Walla District, Walla Walla, Washington.

Normandeau Associates, Inc. and JR Skalski. 2006b. *Comparative Direct Survival and Injury Rates of Juvenile Salmon Passing the New Removable Spillway Weir (RSW) and a Spillbay at Ice Harbor Dam, Snake River*. Report prepared for the U.S. Army Corps of Engineers, Walla Walla District, Walla Walla, Washington.

Normandeau Associates, Inc., JR Skalski, and R Townsend. 2008. *Direct Survival and Injury Evaluation of Juvenile Chinook Salmon Passing John Day Dam Spillway With and Without a Top Spillway Weir*. Normandeau Associates, Inc., Drumore, Pennsylvania.

## **Appendix A**

### **Field Log Data Sheets**

Appendix A contains field log data sheets showing dam operating conditions, release locations and deployment and recovery times for each Sensor Fish release, and other project information for each study period.

## **Spillway Passage**

Test Date	Location	Test Condition	Fish ID	Tag Number	Deployment Time	Recovery Time	File Name	Gate Setting (ft)	Forebay Elevation (ft)	Tailwater Elevation (ft)	Head	
7/13/2009	SB3	1.5 ft	114	8 961	11:35	11:38	f114_SB3_PT1	1.5	1560.94	1200.30	360.64	
			723	8 831	11:36	11:38	-----					
			725	8 870	16:06	16:13	f725_SB3_pt2	1.5	1560.94	1200.30	360.64	
		Control	1.5-SB3	705	8 851	12:45	12:47	F705_Control	1.5	1560.94	1200.30	360.64
	SB6	3.5 ft	722	8 841	13:41	13:52	f722_SB6_PT1	3.5	1560.94	1200.30	360.64	
			635	8 971	14:49	14:53	F635_sb6_pt2	3.5	1560.94	1200.30	360.64	
	Control	3.5-SB6	113	8 891	15:29	15:36	f113_control6	3.5	1560.94	1200.30	360.64	
7/14/2009	SB3	1.5 ft	725	8 870	8:46	9:09	f725_SB3_1_1	1.5	1560.82	1200.04	360.38	
			101	8 971	10:22	10:28	f101_SB3_1_2	1.5	1560.83	1199.00	361.82	
			722	8 841	10:26	10:37	f722_SB3_1_3	1.5	1560.83	1199.00	361.82	
			711	8 821	11:52	12:00	f711_SB3_1_4	1.5	1560.83	1199.13	361.70	
	Control	SB6 high	103	8 864	13:15	13:23	f103_controlH_1	3.5	1560.85	1200.36	360.49	
	Control	SB6 low	114	8 961	16:59	17:04	f114_control_L_1	1.5	1560.80	1202.53	357.27	
	SB6	3.5 ft	117	8 831	14:08	14:21	f117_SB6_3_1	3.5	1560.83	1200.36	360.49	
			661	8 911	15:20	15:49	f661_SB6_3_2	3.5	1560.83	1200.23	360.50	
			714	8 861	15:26	15:32	-----		1560.83	1200.23	360.50	
			725	8 870	15:25	15:30	-----		1560.83	1200.23	360.50	
			101	8 971	16:12	16:23	f101_SB6_3_3	3.5	1560.83	1202.30	358.50	
				722	8 841	16:18	16:27	f722_SB6_3_4	3.5	1560.83	1202.30	358.50
	7/15/2009	SB3	1.5 ft	722	8 841	8:47	8:57	f722_SB3_1_5	1.5	1560.63	1200.36	360.27
101				8 971	8:51	8:55	f101_SB3_1_6	1.5	1560.63	1200.36	360.27	
711				8 821	9:29	9:41	f711_SB3_1_7	1.5	1560.63	1200.90	359.73	
661				8 911	9:33	9:40	f661_SB3_1_8	1.5	1560.63	1200.90	359.73	

A.3

Test Date	File Name	Spillbay 6 (cfs)	Spillbay 3 (cfs)	Gage Counter SB 6	Gage Counter SB 3	Number of Turbines Operating	Total Powerhouse flow (cfs)	Total Project Flow (cfs) <sup>(a)</sup>	Approximate Velocity at Plunge
7/13/2009	f114_SB3_PT1	4600	1549	1100	38	0	0	2600	152.34
	-----								
	f725_SB3_pt2	0	1549	0	0	1	1960	3509	152.34
	F705_Control	4600	1549	1100	38	0	0	2009	
	f722_SB6_PT1	3008	0	70	0	0	0	3008	152.34
	F635_sb6_pt2	3008	0	70	0	0	0	3008	152.34
	f113_control6	3008	0	70	0	0	0	3008	
7/14/2009	f725_SB3_1_1	460	1549	11	38	0	0	2009	152.37
	f101_SB3_1_2	50	1549	1	38	0	0	1599	152.59
	f722_SB3_1_3	50	1549	1	38	0	0	1599	152.59
	f711_SB3_1_4	50	1549	1	38	0	0	1599	152.56
	f103_controlH_1	3008	0	70	0	0	0	3008	
	f114_control_L_1	1549	0	36	0	1	1960	3509	
	f117_SB6_3_1	3008	0	70	0	0	0	3008	152.30
	f661_SB6_3_2	3008	0	70	0	1	1960	4968	152.33
	-----	3008	0	70	0	1	1960	4968	152.33
	-----	3008	0	70	0	1	1960	4968	152.33
	f101_SB6_3_3	3008	0	70	0	1	1960	4968	151.89
	f722_SB6_3_4	3008	0	70	0	1	1960	4968	151.89
7/15/2009	f722_SB3_1_5	460	1549	11	38	0	0	2009	152.26
	f101_SB3_1_6	460	1549	11	38	0	0	2009	152.26
	f711_SB3_1_7	460	1549	11	38	0	0	2009	152.14
	f661_SB3_1_8	460	1549	11	38	0	0	2009	152.14

A.4



Test Date	Location	Test Condition	Fish ID	Tag Number	Deployment Time	Recovery Time	File Name	Gate Setting (ft)	Forebay Elevation (ft)	Tailwater Elevation (ft)	Head	
7/15/2009	SB3	1.5 ft	117	8 831	10:09	10:15	-----		1560.63	1200.40	360.23	
			116	8 870	10:05	10:09	f116_SB3_1_9	1.5	1560.63	1200.40	360.23	
			114	8 961	10:38	10:49	f114_SB3_1_10	1.5	1560.63	1200.40	360.23	
				103	8 864	10:42	10:50	f103_SB3_1_11	1.5	1560.63	1200.40	360.23
	Control	SB6 low	106	8 881	11:29	11:40	f106_control_L_2	1.5	1560.63	1200.40	360.23	
	Control	SB6 low	104	8 851	11:31	11:38	f104_control_L_3	1.5	1560.63	1200.40	360.23	
	SB6	~3.5	722	8 841	12:25	12:37	f722_SB6_3_5	3.5	1560.63	1200.30	360.33	
			101	8 971	12:29	12:41	f101_SB6_3_6	3.5	1560.63	1200.30	360.33	
			109	8 891	13:12	13:22	f109_SB6_3_7	3.5	1560.62	1199.70	360.92	
			711	8 821	13:16	13:26	f711_SB6_3_8	3.5	1560.62	1199.70	360.92	
			661	8 911	14:00	14:16	f661_SB6_3_9	3.5	1560.62	1202.10	358.52	
			116	8 870	14:04	14:11	-----		1560.62	1202.10	358.52	
			114	8 961	14:52	15:11	f114_SB6_3_10	3.5	1560.58	1202.10	358.48	
			103	8 864	14:56	15:04	f103_SB6_3_11	3.5	1560.58	1202.10	358.48	
		Control	SB6 high	117	8 831	15:31	15:45	f117_Control_H_2	3.5	1560.54	1202.10	358.44
		106	8 881	15:34	15:42	f106_Control_H_3	3.5	1560.54	1202.10	358.44		
7/16/2009	SB6	~3.5	114	8 961	7:36	8:03	f114_SB6_3_12	3.5	1560.35	1200.30	360.05	
			661	8 911	7:40	7:47	f661_SB6_3_13	3.5	1560.35	1200.30	360.05	
			711	8 821	8:21	8:36	f711_SB6_3_14	3.5	1560.34	1200.50	360.04	
			722	8 841	8:21	8:44	f722_SB6_3_15	3.5	1560.34	1200.50	360.04	
			117	8 831	9:10	9:14	-----		1560.34	1199.20	361.14	
			106	8 881	9:14	9:25	f106_SB6_3_16	3.5	1560.34	1199.20	361.14	
			103	8 864	10:04	10:32	f103_SB6_3_17	3.5	1560.34	1199.20	361.14	
			101	8 971	10:09	10:17	f101_SB6_3_18	3.5	1560.34	1199.20	361.14	

Test Date	File Name	Spillbay 6 (cfs)	Spillbay 3 (cfs)	Gage Counter SB 6	Gage Counter SB 3	Number of Turbines Operating	Total Powerhouse flow (cfs)	Total Project Flow (cfs) <sup>(a)</sup>	Approximate Velocity at Plunge
7/15/2009	-----	460	1549	11	38	0	0	2009	152.25
	f116_SB3_1_9	460	1549	11	38	0	0	2009	152.25
	f114_SB3_1_10	460	1549	11	38	0	0	2009	152.25
	f103_SB3_1_11	460	1549	11	38	0	0	2009	152.25
	f106_control_L_2	1537	0	36	0	0	0	1259	
	f104_control_L_3	1537	0	36	0	0	0	1259	
	f722_SB6_3_5	3008	0	70	0	0	0	3008	152.27
	f101_SB6_3_6	3008	0	70	0	0	0	3008	152.27
	f109_SB6_3_7	3008	0	70	0	0	0	3008	152.40
	f711_SB6_3_8	3008	0	70	0	0	0	3008	152.40
	f661_SB6_3_9	3008	0	70	0	0	0	3008	151.89
	-----	3008	0	70	0	0	0	3008	151.89
	f114_SB6_3_10	3008	0	70	0	1	1962	4970	151.88
	f103_SB6_3_11	3008	0	70	0	1	1962	4970	151.88
	f117_Control_H_2	3008	0	70	0	1	1962	4970	
	f106_Control_H_3	3008	0	70	0	1	1962	4970	
7/16/2009	f114_SB6_3_12	3008	0	70	0	0	0	3008	152.21
	f661_SB6_3_13	3008	0	70	0	0	0	3008	152.21
	f711_SB6_3_14	3008	0	70	0	0	0	3008	152.17
	f722_SB6_3_15	3008	0	70	0	0	0	3008	152.17
	-----	3008	0	70	0	0	0	3008	152.44
	f106_SB6_3_16	3008	0	70	0	0	0	3008	152.44
	f103_SB6_3_17	3008	0	70	0	0	0	3008	152.44
	f101_SB6_3_18	3008	0	70	0	0	0	3008	152.44

Test Date	Location	Test Condition	Fish ID	Tag Number	Deployment Time	Recovery Time	File Name	Gate Setting (ft)	Forebay Elevation (ft)	Tailwater Elevation (ft)	Head
7/16/2009	Control	SB6 high	705	8 870	10:54	11:07	-----				
			104	8 851	10:59	11:05	f104_control_H_4	3.5	1560.34	1199.80	360.54
	SB3	1.5 ft	109	8 891	11:51	12:05	f109_SB3_1_12	1.5	1560.33	1202.10	358.23
			114	8 961	11:54	12:04	f114_SB3_1_13	1.5	1560.33	1202.10	358.23
			661	8 911	12:48	12:56	f661_SB3_1_14	1.5	1560.33	1201.90	358.43
			711	8 821	12:44	12:57	f711_SB3_1_15	1.5	1560.33	1201.90	358.43
			722	8 841	13:40	13:46	f722_SB3_1_16	1.5	1560.33	1200.00	360.33
			106	8 881	13:37	13:48	f106_SB3_1_17	1.5	1560.33	1200.00	360.33
			119	8 831	14:24	14:28	f119_SB3_1_18	1.5	1560.33	1199.80	360.53
			103	8 864	14:27	14:34	f103_SB3_1_19	1.5	1560.33	1199.80	360.53
	Control	SB6 low	101	8 971	15:21	15:26	f101_control_L_4	1.5	1560.33	1199.80	360.53
			723	8 870	15:17	15:28	-----				
7/17/2009	SB6	~3.5	104	8 851	7:53	8:11	F104_SB6_3_19	3.5	1560.16	1201.70	359.09
			656	8 870	7:56	8:08	-----		1560.16	1201.70	359.09
			109	8 891	8:39	8:56	f109_SB6_3_20	3.5	1560.16	1201.70	359.09
			102	8 841	8:43	8:57	f102_SB6_3_21	3.5	1560.16	1201.70	359.09
			711	8 821	9:36	9:53	f711_SB6_3_22	3.5	1560.16	1200.70	360.09
			729	8 931	9:40	9:45	f114_SB6_3_23	3.5	1560.16	1200.70	360.09
			119	8 831	10:30	10:46	f119_SB6_3_24	3.5	1560.15	1199.90	360.25
			687	8 881	10:34	10:40	<del>f687_SB6_3_25</del>				
	Control	SB6 high	103	8 864	12:24	12:43	f103_control_H_5	3.5	1560.13	1200.20	360.11
			SB3	1.5 ft	661	8 911	13:55	14:13	f661_SB3_1_20	1.5	1560.12
	664				14:00	14:15	-----				
	104	8 851			14:53	14:59	-----		1560.09	1203.70	356.39
	102	8 841			14:58	15:04	-----				
	109	8 131			15:46	15:50	f109_SB3_1_21	1.5	1560.04	1202.80	357.24
	Control	SB6 low	711	8 821	16:25	16:28	f711_SB3_1_22	1.5	1560.04	1202.80	357.24
106			8 881	17:05	17:11	f106_control_L_5	1.5	1560.03	1203.10	356.93	

A.7

Test Date	File Name	Spillbay 6 (cfs)	Spillbay 3 (cfs)	Gage Counter SB 6	Gage Counter SB 3	Number of Turbines Operating	Total Powerhouse flow (cfs)	Total Project Flow (cfs) <sup>(a)</sup>	Approximate Velocity at Plunge
7/16/2009	-----								
	f104_control_H_4	3008	0	70	0	0	0	3008	
	f109_SB3_1_12	460	1549	11	38	0	0	2009	151.83
	f114_SB3_1_13	460	1549	11	38	0	0	2009	151.83
	f661_SB3_1_14	460	1549	11	38	0	0	2009	151.87
	f711_SB3_1_15	460	1549	11	38	0	0	2009	151.87
	f722_SB3_1_16	460	1549	11	38	0	0	2009	152.27
	f106_SB3_1_17	460	1549	11	38	0	0	2009	152.27
	f119_SB3_1_18	460	1549	11	38	1	1970	3979	152.31
	f103_SB3_1_19	460	1549	11	38	1	1970	3979	152.31
	f101_control_L_4	1537	0	36	0	1	1970	3607	
	-----								
7/17/2009	F104_SB6_3_19	3008	0	70	0	0	0	3008	151.88
	-----	3008	0	70	0	0	0	3008	151.88
	f109_SB6_3_20	3008	0	70	0	0	0	3008	151.88
	f102_SB6_3_21	3008	0	70	0	0	0	3008	151.88
	f711_SB6_3_22	3008	0	70	0	0	0	3008	152.09
	f114_SB6_3_23	3008	0	70	0	0	0	3008	152.09
	f119_SB6_3_24	3008	0	70	0	0	0	3008	152.25
	<del>f687_SB6_3_25</del>								
	f103_control_H_5	3008	0	70	0	0	0	3008	
	f661_SB3_1_20	460	1549	11	38	1	1970	3979	151.78
	-----								
	-----	460	1549	11	38	1	1970	3979	151.44
	-----								
	f109_SB3_1_21	460	1549	11	38	1	1970	3979	151.62
	f711_SB3_1_22	460	1549	11	38	1	1970	3979	151.62
	f106_control_L_5	1549	0	36	0	1	1970	3519	

A.8

Test Date	Location	Test Condition	Fish ID	Tag Number	Deployment Time	Recovery Time	File Name	Gate Setting (ft)	Forebay Elevation (ft)	Tailwater Elevation (ft)	Head
7/19/2009	SB6	1.5 ft	711	8 821	8:09	8:23	f711_SB6_1_1	1.5	1559.61	1200.30	359.31
			106	8 881	8:13	8:18	f106_SB6_1_2	1.5	1559.61	1200.30	359.31
			114	8 931	8:51	9:08	f114_SB6_1_3	1.5	1559.61	1200.30	359.31
			119	8 831	8:56	9:08	f119_SB6_1_4	1.5	1559.61	1200.30	359.31
			661	8 911	9:25	9:40	f661_SB6_1_6	1.5	1559.61	1201.40	359.21
			722	8 841	9:29	9:40	f722_SB6_1_5	1.5	1559.61	1201.40	359.21
			Control	SB6 low	109	8 131	10:04	10:10	f109_Control_L2_1	1.5	1559.61
	SB3	3.5 ft	101	8 870	10:45	10:51	f101_SB3_3_1	3.5	1559.61	1202.00	357.61
			103	8 864	10:49	10:55	f103_SB3_3_2	3.5	1559.61	1202.00	357.61
			106	8 881	11:35	11:52	f106_SB3_3_3	3.5	1559.61	1202.10	357.51
			114	8 931	11:40	11:52	-----				
			119	8 111	12:18	12:23	f119_SB3_3_4	3.5	1559.58	1200.50	359.08
			722	8 841	12:23	12:29	f722_SB3_3_5	3.5	1559.58	1200.50	359.08
			Control	SB6 high	711	8 821	13:17	13:25	f711_Control_H2_1	3.5	1559.57
7/20/2009	SB3	3.5 ft	106	8 881	7:39	7:53	-----		1559.30	1200.20	359.10
			661	8 131	7:45	7:57	-----		1559.30	1200.20	359.10
			711	8 821	8:33	8:40	f711_SB3_3_6	3.5	1559.30	1201.40	357.90
			119	8 111	8:39	8:46	f119_SB3_3_7	3.5	1559.30	1201.40	357.90
	Control	SB6 high	103	8 864	10:02	10:21	f103_control_H2_2	3.5	1559.26	1200.70	358.56

Test Date	File Name	Spillbay 6 (cfs)	Spillbay 3 (cfs)	Gage Counter SB 6	Gage Counter SB 3	Number of Turbines Operating	Total Powerhouse flow (cfs)	Total Project Flow (cfs) <sup>(a)</sup>	Approximate Velocity at Plunge	
7/19/2009	f711_SB6_1_1	1560	0	36	0	0	0	1560	152.06	
	f106_SB6_1_2	1560	0	36	0	0	0	1560	152.06	
	f114_SB6_1_3	1560	0	36	0	0	0	1560	152.06	
	f119_SB6_1_4	1560	0	36	0	0	0	1560	152.06	
	f661_SB6_1_6	1560	0	36	0	0	0	1560	151.82	
	f722_SB6_1_5	1560	0	36	0	0	0	1560	151.82	
	f109_Control_L2_1	1560	0	36	0	0	0	1560		
	f101_SB3_3_1	460	2938	11	70	0	0	3398	151.70	
	f103_SB3_3_2	460	2938	11	70	0	0	3398	151.70	
	f106_SB3_3_3	460	2938	11	70	0	0	3398	151.67	
	-----									
	f119_SB3_3_4	460	2938	11	70	0	0	3398	152.01	
	f722_SB3_3_5	460	2938	11	70	0	0	3398	152.01	
f711_Control_H2_1	3008	0	70	0	0	0	3008			
7/20/2009	-----	460	2858	11	70	0	0	3318	152.01	
	-----	460	2858	11	70	0	0	3318	152.01	
	f711_SB3_3_6	460	2858	11	70	0	0	3318	151.76	
	f119_SB3_3_7	460	2858	11	70	0	0	3318	151.76	
	f103_control_H2_2	2925	0	70	0	0	0	2925		

Test Date	Location	Test Condition	Fish ID	Tag Number	Deployment Time	Recovery Time	File Name	Gate Setting (ft)	Forebay Elevation (ft)	Tailwater Elevation (ft)	Head
7/20/2009	SB6	1.5 ft	722	8 841	10:55	11:06	f722_SB6_1_7	1.5	1559.25	1201.20	358.05
			102	8 271	10:59	11:04	f102_SB6_1_8	1.5	1559.25	1201.20	358.05
			101	8 870	11:32	11:36	f101_SB6_1_9	1.5	1559.25	1201.20	358.05
			109	8 131	11:36	11:43	f109_SB6_1_10	1.5	1559.25	1201.20	358.05
			711	8 821	12:08	12:11	f711_SB6_1_11	1.5	1559.24	1200.30	358.94
			119	8 111	12:14	12:22	f119_SB6_1_12	1.5	1559.24	1200.30	358.94
			Control	SB6 low	103	8 864	13:27	13:41	f103_control_L2_2	1.5	1559.24
7/21/2009	SB6	1.5 ft	109	8 131	8:03	8:16	f109_SB6_1_12	1.5	1559.11	1200.90	358.21
			101	8 870	8:10	8:18	f101_SB6_1_13	1.5	1559.11	1200.90	358.21
			722	8 841	8:46	9:03	f722_SB6_1_15	1.5	1559.11	1200.90	358.21
			711	8 821	8:54	8:57	f711_SB6_1_16	1.5	1559.11	1200.90	358.21
			103	8 864	9:41	9:54	f103_SB6_1_17	1.5	1559.11	1200.90	358.21
			119	8 111	9:49	9:52	-----		1559.11	1200.90	358.21
	Control	SB6 low	109	8 131	10:32	10:41	f109_control_L2_3	1.5	1559.10	1201.00	358.10

Test Date	File Name	Spillbay 6 (cfs)	Spillbay 3 (cfs)	Gage Counter SB 6	Gage Counter SB 3	Number of Turbines Operating	Total Powerhouse flow (cfs)	Total Project Flow (cfs) <sup>(a)</sup>	Approximate Velocity at Plunge
7/20/2009	f722_SB6_1_7	1559	0	36	0	0	0	1559	151.79
	f102_SB6_1_8	1559	0	36	0	0	0	1559	151.79
	f101_SB6_1_9	1559	0	36	0	0	0	1555	151.79
	f109_SB6_1_10	1559	0	36	0	0	0	1555	151.79
	f711_SB6_1_11	1559	0	36	0	0	0	1559	151.98
	f119_SB6_1_12	1559	0	36	0	0	0	1559	151.98
	f103_control_L2_2	1559	0	36	0	0	0	1559	
7/21/2009	f109_SB6_1_12	1559	0	36	0	0	0	1559	151.82
	f101_SB6_1_13	1559	0	36	0	0	0	1559	151.82
	f722_SB6_1_15	1559	0	36	0	0	0	1559	151.82
	f711_SB6_1_16	1559	0	36	0	0	0	1559	151.82
	f103_SB6_1_17	1559	0	36	0	0	0	1559	151.82
	-----	1559	0	36	0	0	0	1559	151.82
	f109_control_L2_3	1559	0	36	0	0	0	1559	

(a) Readings taken prior to the close of spillgate.



## **Turbine Passage**

A.15

Date	Test Condition	Fish ID	Tag Number	Deployment Time	Recovery Time	File Name	Barometric Pressure (hPa)	Forebay	Tailwater	Head	Turbine Unit 2 (MW)	Turbine Discharge (kcfs)	
10/20/2009		694	x 095	9:11	9:22	SF694DDT1	961	1513.43	1202	311.43	50.7	2.19	
		P1	x 174	9:13	9:23			1513.43	1202	311.43	50.7	2.19	
		711	x 163	10:19	10:20			1513.37	1202.3	311.07	49.7	2.16	
			103	x 104	10:18	10:20	SF103DDT3		1513.37	1202.3	311.07	49.7	2.16
			109	x 231	10:54	10:57	SF109_4		1513.32	1201.9	311.42	49.4	2.15
			694	x 095	10:54	10:56	SF694_5		1513.32	1201.9	311.42	49.4	2.15
			121	x 124	11:37	11:41	SF121_6		1513.32	1201.9	311.42	49.4	2.15
			103	x 104	11:28	11:31	SF103_7		1513.32	1201.9	311.42	49.4	2.15
		Control	109	x 231	13:02	13:10	SF109_C8		1513.21	1202.2	311.01	51	2.23
		Control	121	x 124	12:56	13:00			1513.21	1202.2	311.01	51	2.23
			694	x 095	13:41	13:42	SF694_10		1513.21	1202.2	311.01	51	2.23
			103	x 104	13:40	13:42	SF103_11		1513.21	1202.2	311.01	51	2.23
			121	x 124	~15:30	15:xx	SF121_9	959	1513.1	1202.2	310.9	51.2	2.23
			109	x 231	~15:30	15:xx	SF109_13		1513.1	1202.2	310.9	51.2	2.23
10/21/2009		120	x 095	10:04	10:08	SF120_14	959	1512.14	1202.3	309.84	50.1	2.2	
		121	x 124	10:05	10:14	Sf121_15		1512.14	1202.3	309.84	50.1	2.2	
		103	x 104	10:03	10:09	SF103_16		1512.14	1202.3	309.84	50.1	2.2	
			109	x 231	10:39	10:42	sf109_17	959.2	1512.14	1202.3	309.84	50.1	2.2
			694	x 124	10:39	10:42			1512.14	1202.3	309.84	50.1	2.2
			103	x 104	11:01	11:05	sf103_19	959.4	1512.11	1202.1	310.01	50.3	2.2
			120	x 095	11:02	11:04			1512.11	1202.1	310.01	50.3	2.2
			103	x 104	11:44	11:48	sf103_21		1512.11	1202.1	310.01	50.3	2.2
			109	x 231	11:43	11:49	sf109_22		1512.11	1202.1	310.01	50.3	2.2
			121	x 124	12:45	12:xx	sf121_23		1512.06	1202.1	309.96	50.5	2.2
			109	x 231	12:46	12:48	sf109_24	959.6	1512.06	1202.1	309.96	50.5	2.2

## **Regulating Outlet Passage**

A.19

Test Date	Test Condition	Fish ID	Tag Number	Deployment Time	Recovery Time	File Name	Pressure (hPa)	Notes	Forebay EL (ft)	Tailwater Elevation (ft)
12/8/09	1 ft	103	8 911	9:48	9:57	f103_1_1	965.1		1443.41	1201.05
	5 ft	931	8 371	10:31	10:41	f931_5_1		1443.38	1201.5	
	1 ft	923	8 851	11:21	11:29	f923_1_2		1443.32	1202.43	
	1 ft	121	8 341	11:25	11:29	f121_1_3		1443.32	1202.43	
	5 ft	924	8 891	12:10	12:20	f924_5_2		1443.23	1202.23	
	5 ft	932	8 351	12:15	12:23	f932_5_3		1443.23	1202.23	
	1 ft	109	8 681	13:08	13:22	f109_1_4		1443.09	1202.52	
	1 ft	930	8 841	13:13	13:21	f930_1_5		1443.09	1202.52	
	5 ft	913	8 8821	14:01	14:07	f913_5_4		1443.01	1202.52	
	5 ft	908	8 831	14:05	14:12	f908_5_5	965.7	1443.01	1202.52	
12/9/09	5 ft	914	9 931	9:25	9:39	f914_5_6	970.5		1441.28	1202.53
	5 ft	923	8 851	9:28	9:39	f923_5_7		1441.28	1202.53	
	1 ft	931	8 371	10:17	10:24	f931_1_6		1441.4	1202.59	
	1 ft	908	8 831	10:19	10:34	f908_1_7	1441.4	1202.59		
	1 ft	930	8 841	11:07	11:16	f930_1_8	969.0	1441.03	1202.63	
	1 ft	121	8 341	11:09	11:15	f121_1_9	1441.03	1202.63		
	5 ft	924	8 891	11:58	12:03	f924_5_8	967.9	1440.97	1202.59	
	5 ft	103	8 911	12:00	12:12	f103_5_9	1440.97	1202.59		
	Control	932	8 351	12:45	13:02	f932_C	974.0	1440.97	1202.59	

Test Date	Test Condition	Fish ID	Tag Number	Deployment Time	Recovery Time	File Name	Barometric Pressure	Notes	Forebay EL (ft)	Tailwater Elevation (ft)
	5 ft	913	8 821	13:55	14:09	f913_5_10			1440.84	1202.56
	5 ft	914	9 931	13:59	14:09	f914_5_11			1440.84	1202.56
	1 ft	923	8 851	14:33	14:40	f923_1_10			1440.76	1202.58
	1 ft	109	8 681	14:35	14:40	f109_1_11			1440.76	1202.58
	1 ft	930	8 841	15:11	15:21	f930_1_12			1440.6	1202.6
	1 ft	931	8 371	15:09	15:22	f931_1_13			1440.6	1202.6
12/10/09	1 ft	121	8 341	10:28	10:35	f121_1_14	964.7		1438.87	1202.54
	1 ft	924	8 891	10:29	10:36			Data Interrupt		
	5 ft	103	8 911	11:01	11:12	f103_5_12	964.5		1438.76	1202.49
	5 ft	908	8 831	11:03	11:13	f908_5_13			1438.76	1202.49
	1 ft	913	8 821	11:51	12:02	f913_1_15	964.0		1438.76	1202.49
	1 ft	914	9 931	11:54	12:02	f914_1_16			1438.76	1202.49
	5 ft	923	8 851	12:29	12:39	f923_5_14	963.1		1438.65	1202.7
	1 ft	932	8 351	13:08	13:17	f932_1_17	962.4		1438.55	1201.49
	5 ft	930	8 841	13:53	14:04	f930_5_15	961.8		1438.55	1201.49
	5 ft	931	8 371	13:56	14:04	f931_5_16			1438.55	1201.49
12/11/09	5 ft	109	8 681	9:37	9:46	f109_5_17	28.35		1437.97	1201.44
	5 ft	908	8 831	9:39	9:47	f908_5_18			1437.97	1201.44
	5 ft	121	8 341	9:39	9:47	f121_5_19			1437.97	1201.44

## **Appendix B**

### **Data Summary Tables for Each Sensor Fish Release**

## **Spillway Passage**

File	Time (s)	AdjTime (s)	Acceleration Magnitude (g)	Event Type	Location
f114_SB3_PT1	10.063	0.612	156.2	Strike	Chute
	10.9235	1.4725	152.3	Strike	Chute
	12.484	3.033	139.9	Strike	Chute
	10.3085	0.8575	135.5	Strike	Chute
	13.5675	4.1165	105.2	Strike	Chute
f725_SB3_pt2	19.159	5.692	111.4	Strike	Chute
	15.178	1.711	104.3	Strike	Chute
f725_SB3_1_1	10.6285	1.6995	152.3	Strike	Chute
	12.5755	3.6465	141.6	Strike	Chute
	14.9955	6.0665	140.7	Strike	Chute
	13.135	4.206	136.3	Strike	Chute
	12.1365	3.2075	135.1	Strike	Chute
	14.801	5.872	109.1	Strike	Chute
	15.367	6.438	109.4	Strike	SB/tr
	15.504	6.575	106.9	Strike	SB/tr
12.3075	3.3785	106.1	Strike	Chute	
f101_SB3_1_2	11.0475	1.8175	157	Strike	Chute
	16.0125	6.7825	151.7	Strike	SB/tr
	15.1805	5.9505	133.5	Strike	Chute
	12.354	3.124	123.9	Strike	Chute
	10.775	1.545	116.1	Strike	Chute
	15.2085	5.9785	111.3	Strike	Chute
	12.783	3.553	110.5	Strike	Chute
f722_SB3_1_3	11.722	3.447	146.4	Strike	Chute
f711_SB3_1_4	12.034	4.0245	204.2	Strike	Chute
	12.23	4.2205	178.8	Strike	Chute
	14.3065	6.297	138.2	Strike	SB/tr
	14.9685	6.959	134.6	Strike	SB/tr
	13.266	5.2565	130.5	Strike	Chute
	12.3365	4.327	126.5	Strike	Chute
	14.1525	6.143	121	Strike	SB/tr
	10.69	2.6805	117.6	Strike	Chute
	11.267	3.2575	112.6	Strike	Chute
	10.347	2.3375	110.6	Strike	Chute
	13.246	5.2365	107.3	Strike	Chute
f722_SB3_1_5	14.0815	5.2155	126.4	Strike	Chute
	12.0615	3.1955	118	Strike	Chute
	12.6175	3.7515	103.8	Strike	Chute
f101_SB3_1_6	13.644	2.05	130.5	Strike	Chute
	15.456	3.862	114.3	Strike	Chute
	15.335	3.741	106.6	Strike	Chute



File	Time (s)	AdjTime (s)	Acceleration Magnitude (g)	Event Type	Location
f711_SB3_1_7	10.7705	1.7725	156.5	Strike	Chute
	10.0765	1.0785	119.9	Strike	Chute
	10.241	1.243	116.9	Strike	Chute
	15.654	6.656	113.3	Strike	SB/tr
	12.2065	3.2085	108.4	Strike	Chute
f661_SB3_1_8	15.3265	7.2305	163.2	Strike	SB/tr
	9.509	1.413	150.1	Strike	Chute
	14.33	6.234	142.3	Strike	Chute
	11.041	2.945	127	Strike	Chute
	11.22	3.124	111.7	Strike	Chute
	11.883	3.787	105.5	Strike	Chute
f116_SB3_1_9	16.346	4.88	96.8	Strike	Chute
f114_SB3_1_10	11.018	2.1855	166.3	Strike	Chute
	15.6865	6.854	123.3	Strike	SB/tr
	15.2265	6.394	123.2	Strike	Chute
	12.871	4.0385	114.9	Strike	Chute
	11.305	2.4725	106	Strike	Chute
f103_SB3_1_11	12.5	4.886	201.5	Strike	Chute
	9.381	1.767	170.4	Strike	Chute
	14.4595	6.8455	154.5	Strike	SB/tr
	11.3605	3.7465	132.1	Strike	Chute
	15.3	7.686	130.6	Strike	SB/tr
	14.226	6.612	116	Strike	SB/tr
	10.402	2.788	105.9	Strike	Chute
	10.6245	3.0105	104.8	Strike	Chute
14.387	6.773	95.8	Strike	SB/tr	
f109_SB3_1_12	13.073	3.8925	131.8	Strike	Chute
	10.41	1.2295	129.7	Strike	Chute
	10.513	1.3325	128.4	Strike	Chute
	11.1385	1.958	123.5	Strike	Chute
	10.278	1.0975	122.4	Strike	Chute
	16.008	6.8275	117.8	Strike	SB/tr
	12.7445	3.564	116.8	Strike	Chute
f114_SB3_1_13	13.6015	4.8625	168.8	Strike	Chute
	11.228	2.489	152.1	Strike	Chute
	15.7915	7.0525	124.5	Strike	SB/tr
	10.249	1.51	107.4	Strike	Chute
	13.9175	5.1785	98.8	Strike	Chute
	11.451	2.712	97.8	Strike	Chute
f661_SB3_1_14	11.3185	3.647	115.1	Strike	Chute
f711_SB3_1_15	8.392	2.211	189.8	Strike	Chute
	8.8025	2.6215	110.2	Strike	Chute
	7.9725	1.7915	103.2	Strike	Chute

File	Time (s)	AdjTime (s)	Acceleration Magnitude (g)	Event Type	Location
f722_SB3_1_16	13.9095	2.9255	161.6	Strike	Chute
	18.0415	7.0575	131.6	Strike	SB/tr
	11.71	0.726	123.2	Strike	Chute
	15.262	4.278	115	Strike	Chute
f106_SB3_1_17	14.16	3.0535	178.2	Strike	Chute
	12.7175	1.611	141.5	Strike	Chute
	12.5395	1.433	136.8	Strike	Chute
	12.3345	1.228	112.1	Strike	Chute
	16.8645	5.758	104.8	Strike	Chute
f119_SB3_1_18	10.5185	3.1155	190.8	Strike	Chute
	9.06	1.657	183.9	Strike	Chute
	9.8905	2.4875	97.5	Strike	Chute
f103_SB3_1_19	14.4565	4.55	151.3	Strike	Chute
	12.6835	2.777	145.7	Strike	Chute
	13.6345	3.728	120.2	Strike	Chute
	14.5925	4.686	112.9	Strike	Chute
	18.0745	8.168	105.7	Strike	SB/tr
	16.3	6.3935	101.3	Strike	Chute
	12.5135	2.607	98.6	Strike	Chute
f661_SB3_1_20	30.3315	6.1875	139.7	Strike	Chute
	29.386	5.242	137.5	Strike	Chute
f109_SB3_1_21	12.4665	1.856	156	Strike	Chute
	17.311	6.7005	141.7	Strike	SB/tr
	14.3785	3.768	129	Strike	Chute
	13.1895	2.579	118	Strike	Chute
	13.515	2.9045	115.6	Strike	Chute
	12.5585	1.948	114.3	Strike	Chute
f711_SB3_1_22	22.4025	6.6675	161.7	Strike	SB/tr
	17.8565	2.1215	154.5	Strike	Chute
	17.622	1.887	129.8	Strike	Chute
	18.7635	3.0285	121.2	Strike	Chute
	24.0775	8.3425	118.8	Strike	SB/tr
	23.652	7.917	114.8	Strike	SB/tr
<b>Mean</b>	<b>All:</b>	<b>129.35</b>	<b>Most Severe:</b>	<b>Mean</b>	<b>154.73</b>
<b>Maximum</b>		<b>204.2</b>		<b>Maximum</b>	<b>204.2</b>
<b>Minimum</b>		<b>95.8</b>		<b>Minimum</b>	<b>96.8</b>
<b>SD</b>		<b>23.87</b>		<b>SD</b>	<b>27.39</b>
<b>SE</b>		<b>2.21</b>		<b>SE</b>	<b>5.59</b>

File	Time (s)	AdjTime (s)	Acceleration Magnitude (g)	Event Type	Location
f722_SB6_PT1	16.251	0.583	153.2	Strike	Chute
	17.882	2.214	139.1	Strike	Chute
	21.369	5.701	128	Strike	Chute
	16.925	1.257	124.6	Strike	Chute
	21.1595	5.4915	118.9	Strike	Chute
	21.4275	5.7595	114.3	Strike	Chute
	21.4945	5.8265	110.4	Strike	Chute
	21.627	5.959	108.9	Strike	Chute
	20.2575	4.5895	96.3	Strike	Chute
F635_sb6_pt2	22.5985	4.9655	172.4	Strike	Chute
	18.9795	1.3465	148.8	Strike	Chute
	21.6405	4.0075	131.1	Strike	Chute
	23.3265	5.6935	110.9	Strike	Chute
	24.6445	7.0115	110.7	Strike	SB/tr
	19.35	1.717	107.3	Strike	Chute
	22.1985	4.5655	103.2	Strike	Chute
f117_SB6_3_1	10.692	2.8545	165.4	Strike	Chute
	10.843	3.0055	155.8	Strike	Chute
	14.34	6.5025	118.3	Strike	SB/tr
	8.9105	1.073	103	Strike	Chute
	12.4125	4.575	99.9	Strike	Chute
f661_SB6_3_2	11.9845	3.235	164.1	Strike	Chute
	13.9815	5.232	160.2	Strike	Chute
	15.0015	6.252	140.7	Strike	End
	11.766	3.0165	134.3	Strike	Chute
	10.0165	1.267	130.7	Strike	Chute
	11.6535	2.904	116.3	Strike	Chute
f101_SB6_3_3	14.4405	6.261	128.8	Strike	SB/tr
	14.629	6.4495	111.5	Strike	SB/tr
f722_SB6_3_4	9.465	0.7505	160.8	Strike	Chute
	12.688	3.9735	131.6	Strike	Chute
	11.446	2.7315	127.6	Strike	Chute
	12.7545	4.04	118.6	Strike	Chute
f722_SB6_3_5	14.7995	3.0235	185.2	Strike	Chute
	13.016	1.24	136.7	Strike	Chute
	12.857	1.081	136.4	Strike	Chute
	19.289	7.513	134.5	Strike	SB/tr
	16.1585	4.3825	129.2	Strike	Chute
	16.343	4.567	128.1	Strike	Chute
	12.3705	0.5945	127	Strike	Chute
	18.8845	7.1085	121.1	Strike	SB/tr
	13.0975	1.3215	107.7	Strike	Chute

File	Time (s)	AdjTime (s)	Acceleration Magnitude (g)	Event Type	Location
f101_SB6_3_6	14.1	5.8005	131.9	Strike	SB/tr
	14.065	5.7655	131.1	Strike	SB/tr
	11.539	3.2395	99.7	Strike	Chute
f109_SB6_3_7	14.2985	6.607	161.7	Shear	SB/tr
	14.3205	6.629	159.4	Shear	SB/tr
	9.128	1.4365	128.5	Strike	Chute
	8.681	0.9895	122.3	Strike	Chute
	10.7995	3.108	120	Strike	Chute
	8.6605	0.969	96.2	Strike	Chute
f711_SB6_3_8	12.4245	5.414	147.4	Strike	Chute
	12.057	5.0465	131.4	Strike	Chute
	8.6355	1.25	122.6	Strike	Chute
	10.5235	3.513	114.5	Strike	Chute
	8.357	1.3465	110.7	Strike	Chute
f661_SB6_3_9	15.689	5.7425	129.8	Strike	Chute
	12.9335	2.987	117.8	Strike	Chute
	12.7815	2.835	116.1	Strike	Chute
	16.113	6.1665	96.7	Strike	SB/tr
f114_SB6_3_10	10.8975	3.3735	172.5	Strike	Chute
	10.1845	2.6605	170.9	Strike	Chute
	13.5205	5.9965	129.8	Strike	SB/tr
	12.96	5.436	122.6	Strike	Chute
f103_SB6_3_11	18.178	2.902	190.9	Strike	Chute
	18.061	2.785	153.5	Strike	Chute
	19.9505	4.6745	140.2	Strike	Chute
	29.922	14.646	111.6	Strike	SB/tr
	18.5405	3.2645	117.4	Strike	Chute
	21.416	6.14	97.1	Strike	SB/tr
f114_SB6_3_12	10.128	3.369	170.3	Strike	Chute
	8.662	1.903	166.2	Strike	Chute
	8.142	1.383	144.5	Strike	Chute
	8.1905	1.4315	121.9	Strike	Chute
	8.3765	1.6175	117.2	Strike	Chute
	8.738	1.979	114	Strike	Chute
	9.6955	2.9365	112.1	Strike	Chute
	9.909	3.15	107.4	Strike	Chute

File	Time (s)	AdjTime (s)	Acceleration Magnitude (g)	Event Type	Location
f661_SB6_3_13	7.9125	0.8215	165.8	Strike	Chute
	11.0675	3.9765	136.9	Strike	Chute
	13.7865	6.6955	127.6	Strike	SB/tr
	14.6995	7.6085	118.6	Strike	SB/tr
	8.289	1.198	118.5	Strike	Chute
	8.436	1.345	114.2	Strike	Chute
	7.6325	0.5415	111.1	Strike	Chute
	9.1735	2.0825	109.4	Strike	Chute
	12.6235	5.5325	105.9	Strike	Chute
	14.1595	7.0865	105.8	Strike	SB/tr
	8.052	0.961	102.7	Strike	Chute
f711_SB6_3_14	15.725	3.1	160.1	Strike	Chute
	19.2	6.575	129.3	Strike	SB/tr
	17.2895	4.6645	123.8	Strike	Chute
	16.1355	3.5105	114.2	Strike	Chute
f722_SB6_3_15	15.9125	8.3885	135	Strike	SB/tr
	12.778	5.254	103	Strike	Chute
f106_SB6_3_16	13.7855	2.6515	169.5	Strike	Chute
	13.909	2.775	146.8	Strike	Chute
	14.564	3.43	140.4	Strike	Chute
	17.374	6.24	131.6	Shear	End
f103_SB6_3_17	16.1135	6.0725	200	Strike	Chute
f101_SB6_3_18					
f104_SB6_3_19	7.7205	0.54	145.8	Strike	Chute
	9.6165	2.436	121.3	Strike	Chute
	7.847	0.6665	116.8	Strike	Chute
	11.736	4.5555	113.7	Strike	Chute
	13.7655	6.585	107.1	Strike	SB/tr
f109_SB6_3_20	15.889	5.9255	124.6	Strike	SB/tr
f102_SB6_3_21	15.78	2.369	129.8	Strike	Chute
	19.866	6.455	122.5	Strike	SB/tr
	19.8445	6.4335	119	Shear	SB/tr
f711_SB6_3_22	11.266	2.487	155.2	Shear	Chute
	14.9555	6.1765	150.8	Strike	SB
	11.3365	2.5575	144.2	Strike	Chute
	13.4065	4.6275	143.5	Strike	Chute
	12.2815	3.5025	99.2	Strike	Chute
f114_SB6_3_23	10.306	2.4325	150	Strike	Chute
	10.716	2.8425	104.8	Strike	Chute
	13.8195	5.946	100.6	Shear	SB/tr

File	Time (s)	AdjTime (s)	Acceleration Magnitude (g)	Event Type	Location
f119_SB6_3_24	10.3805	2.745	206.3	Strike	Chute
	10.8795	3.244	197.8	Strike	Chute
	13.8775	6.242	183.7	Strike	Chute
	14.2555	6.62	153.2	Strike	SB/tr
	9.3075	1.672	152.7	Strike	Chute
	10.445	2.8095	139.7	Strike	Chute
	16.098	8.4625	138	Strike	SB/tr
	15.8475	8.212	134.4	Strike	SB/tr
	13.533	5.8975	124.7	Strike	Chute
	9.452	1.8165	123.5	Strike	Chute
	14.432	6.7965	122	Shear	SB/tr
	15.77	8.1345	119.7	Strike	SB/tr
	10.3	2.6645	115.4	Strike	Chute
	9.7625	2.127	112.7	Strike	Chute
13.503	5.8675	106.1	Strike	Chute	
<b>Mean</b>	<b>All:</b>	<b>131.05</b>	<b>Most Severe:</b>	<b>Mean</b>	<b>159.06</b>
<b>Maximum</b>		<b>206.3</b>		<b>Maximum</b>	<b>206.3</b>
<b>Minimum</b>		<b>96.2</b>		<b>Minimum</b>	<b>124.6</b>
<b>SD</b>		<b>23.72</b>		<b>SD</b>	<b>22.26</b>
<b>SE</b>		<b>2.06</b>		<b>SE</b>	<b>4.45</b>
f101_SB3_3_1	17.734	2.028	172.6	Strike	Chute
	22.409	6.703	161	Strike	SB/tr
	19.007	3.301	135.3	Strike	Chute
	20.4405	4.7345	128.6	Strike	Chute
	19.168	3.462	124.6	Strike	Chute
	20.5355	4.8295	112.8	Strike	Chute
	22.272	6.566	100.1	Strike	SB/tr
	17.708	2.002	99.4	Strike	Chute
f103_SB3_3_2	17.1115	2.8175	221.3	Strike	Chute
	17.985	3.691	96.7	Strike	Chute
f106_SB3_3_3	23.583	8.25	170.1	Strike	SB/tr
	23.4265	8.0935	163.9	Shear	SB/tr
	17.3865	2.0535	161.3	Strike	Chute
	21.58	6.247	159.3	Shear	Chute
	17.936	2.603	136.7	Strike	Chute
	15.9105	0.5775	134.3	Strike	Chute
	17.5575	2.2245	118.7	Strike	Chute
17.494	2.161	110.2	Strike	Chute	
f119_SB3_3_4	22.114	3.066	176.9	Strike	Chute
	19.7985	0.7505	142.4	Strike	Chute

File	Time (s)	AdjTime (s)	Acceleration Magnitude (g)	Event Type	Location
f722_SB3_3_5	27.656	1.6545	144.2	Strike	Chute
	28.2505	2.249	118.8	Strike	Chute
	27.969	1.9675	109	Strike	Chute
	29.431	3.4295	103.4	Strike	Chute
	29.304	3.3025	98.6	Strike	Chute
f711_SB3_3_6	19.223	0.849	160.6	Strike	Chute
	24.3395	5.9655	109.9	Strike	End
	24.5725	6.1985	102.1	Shear	SB/tr
	22.4485	4.0745	96.7	Strike	Chute
f119_SB3_3_7	21.749	6.642	179.5	Strike	SB/tr
	21.6885	6.5815	145.7	Strike	SB/tr
	20.1825	5.0755	131.2	Strike	Chute
	18.2915	3.1845	122.8	Strike	Chute
	22.461	7.354	108.1	Strike	SB/tr
	17.833	2.726	103.9	Strike	Chute
	16.733	1.626	102.6	Strike	Chute
	21.9675	6.8605	96.4	Strike	SB/tr
<b>Mean</b>	<b>All:</b>	<b>131.34</b>	<b>Most Severe:</b>	<b>Mean</b>	<b>175.03</b>
<b>Maximum</b>		<b>221.3</b>		<b>Maximum</b>	<b>221.3</b>
<b>Minimum</b>		<b>96.4</b>		<b>Minimum</b>	<b>144.2</b>
<b>SD</b>		<b>30.44</b>		<b>SD</b>	<b>23.64</b>
<b>SE</b>		<b>5.00</b>		<b>SE</b>	<b>8.94</b>
f711_SB6_1_1	23.935	1.861	143.5	Strike	Chute
	23.796	1.722	140.7	Strike	Chute
	28.2805	6.2065	130.7	Strike	End
	29.595	7.521	110.6	Strike	SB/tr
	27.7085	5.6345	110.1	Strike	Chute
f106_SB6_1_2	27.944	2.0815	131.2	Strike	Chute
	27.6655	1.803	123.9	Strike	Chute
	30.2215	4.359	123.5	Strike	Chute
	30.8525	4.99	104.7	Strike	Chute
f114_SB6_1_3	16.069	2.7505	175.3	Strike	Chute
	15.059	1.7405	164.6	Strike	Chute
	15.134	1.8155	157.9	Strike	Chute
	18.301	4.9825	141.1	Strike	Chute
	18.087	4.7685	123.6	Strike	Chute
	15.084	1.7655	115.9	Strike	Chute
	15.0005	1.682	115.6	Strike	Chute

File	Time (s)	AdjTime (s)	Acceleration Magnitude (g)	Event Type	Location
f119_SB6_1_4	28.7125	4.548	175.8	Strike	Chute
	28.268	4.1035	124	Strike	Chute
	25.845	1.6805	123.1	Strike	Chute
	30.594	6.4295	112.5	Strike	SB/tr
	26.8755	2.711	107.9	Strike	Chute
	25.778	1.6135	103.1	Strike	Chute
f722_SB6_1_5	21.861	5.1175	131	Strike	Chute
	23.302	6.5585	123.5	Strike	SB/tr
	21.245	4.5015	115.5	Strike	Chute
	22.714	5.9705	108.2	Strike	Chute
	25.1225	8.379	100.7	Strike	SB/tr
	20.761	4.0175	99.8	Strike	Chute
f661_SB6_1_6	22.777	6.0335	99.7	Strike	Chute
	16.0875	6.7295	150.3	Strike	SB/tr
	14.708	5.35	141.5	Strike	Chute
f722_SB6_1_7	15.8415	6.4835	121	Strike	SB/tr
	19.5755	2.1235	171.5	Strike	Chute
	24.2905	6.8385	151.6	Strike	SB/tr
	23.7365	6.2845	147.3	Strike	Chute
	22.749	5.297	138.8	Strike	Chute
f102_SB6_1_8	24.3585	6.9065	120.6	Strike	SB/tr
	22.592	5.14	98.7	Strike	Chute
	19.9345	2.5405	179.4	Strike	Chute
	19.2845	1.8905	165.1	Strike	Chute
	21.819	4.425	151	Strike	Chute
	23.573	6.179	139.9	Strike	Chute
	19.061	1.667	128.4	Strike	Chute
	19.682	2.288	120.5	Strike	Chute
18.648	1.254	114	Strike	Chute	
f101_SB6_1_9	19.5985	2.2045	117.1	Strike	Chute
	19.9825	1.7395	147.2	Strike	Chute
	20.6555	2.4125	138.8	Strike	Chute
	22.723	4.48	126.7	Strike	Chute
	26.14	7.897	122.9	Strike	SB/tr
	26.2605	8.0175	118.2	Strike	SB/tr
	22.4505	4.2075	116.2	Strike	Chute
	20.9245	2.6815	115.6	Strike	Chute
25.029	6.786	110.8	Strike	SB/tr	



File	Time (s)	AdjTime (s)	Acceleration Magnitude (g)	Event Type	Location
f109_SB6_1_10	22.75	4.453	145.3	Strike	Chute
	25.4355	7.1385	139.8	Strike	SB/tr
	24.141	5.844	135.4	Strike	Chute
	21.2675	2.9705	125.9	Strike	Chute
	20.5435	2.247	120	Strike	Chute
	20.3785	2.0815	115.4	Strike	Chute
	19.4575	1.1605	113.7	Strike	Chute
	22.2135	3.9165	103.8	Strike	Chute
	25.462	7.165	95.6	Shear	SB/tr
f711_SB6_1_11	13.502	1.988	185.2	Strike	Chute
	18.459	6.945	153.2	Strike	End
	12.1995	0.6855	148.9	Strike	Chute
	12.0045	0.4905	143.8	Strike	Chute
	12.455	0.941	130.8	Strike	Chute
	13.7795	2.2655	130.4	Strike	Chute
	16.965	5.451	122.6	Strike	Chute
f119_SB6_1_12	27.1065	2.9245	217.7	Strike	Chute
	29.6485	5.4665	162	Strike	Chute
	29.11	4.928	153.1	Strike	Chute
	28.4295	4.2475	118.2	Strike	Chute
	30.4225	6.2405	112.3	Strike	Chute
	25.952	1.77	95.1	Strike	Chute
f109_SB6_1_12	26.1525	5.529	137.2	Strike	Chute
	25.0245	4.401	118	Strike	Chute
	26.252	5.6285	113.9	Strike	Chute
	27.933	7.2095	95.6	Strike	SB/tr
f101_SB6_1_13	14.1545	2.4975	150.5	Strike	Chute
	14.5415	2.8845	143.7	Strike	Chute
	13.726	2.069	134.9	Strike	Chute
	16.394	4.737	127.2	Strike	Chute
	13.345	1.688	118.2	Strike	Chute
f722_SB6_1_15	19.3925	5.9765	116.8	Strike	Chute
	15.819	2.403	112.1	Strike	Chute
f711_SB6_1_16	21.687	2.7805	151.5	Strike	Chute
	21.1025	2.196	131.1	Strike	Chute
	22.324	3.4175	123.3	Strike	Chute
	25.3305	6.424	116	Strike	End
	24.904	5.9975	99.8	Strike	Chute

File	Time (s)	AdjTime (s)	Acceleration Magnitude (g)	Event Type	Location
f103_SB6_1_17	16.4955	4.5255	125.1	Strike	Chute
	14.0835	2.1135	123.2	Strike	Chute
	13.809	1.839	117.6	Strike	Chute
	18.9735	7.0035	103.6	Strike	SB/tr
	18.01665	6.0465	96.8	Strike	Chute
<b>Mean</b>	<b>All:</b>	<b>129.02</b>	<b>Most Severe:</b>	<b>Mean</b>	<b>154.97</b>
<b>Maximum</b>		<b>217.7</b>		<b>Maximum</b>	<b>217.7</b>
<b>Minimum</b>		<b>95.1</b>		<b>Minimum</b>	<b>116.8</b>
<b>SD</b>		<b>22.41</b>		<b>SD</b>	<b>25.87</b>
<b>SE</b>		<b>2.28</b>		<b>SE</b>	<b>6.27</b>

File	Rate of Change	Acceleration Magnitude at Gate (g)
f114_SB3_PT1	-88.67	6.9
f725_SB3_pt2	-84.67	9.1
f725_SB3_1_1	-88.00	8.9
f101_SB3_1_2	-81.33	8.4
f722_SB3_1_3	-75.67	7.4
f711_SB3_1_4	-89.33	7.9
f722_SB3_1_5	-86.00	8.3
f101_SB3_1_6	-81.33	11.8
f711_SB3_1_7	-75.67	7.9
f661_SB3_1_8	-85.67	8.6
f116_SB3_1_9	-83.00	10.9
f114_SB3_1_10	-95.33	8.9
f103_SB3_1_11	-88.00	9.4
f109_SB3_1_12	-77.00	7.7
f114_SB3_1_13	-85.67	7.8
f661_SB3_1_14	-79.00	8.1
f711_SB3_1_15	-65.33	9.3
f722_SB3_1_16	-82.33	7.2
f106_SB3_1_17	-83.67	8.1
f119_SB3_1_18	-91.33	10.7
f103_SB3_1_19	-88.00	9.7
f661_SB3_1_20	-89.00	8.4
f109_SB3_1_21		8.6
f711_SB3_1_22	-93.00	8.4
Mean	-84.22	8.7
Minimum	-95.33	6.9
Maximum	-65.33	11.8

File	Rate of Change	Acceleration Magnitude at Gate (g)
f101_SB3_3_1	-39.33	4.2
f103_SB3_3_2	-39.00	5.6
f106_SB3_3_3	-30.00	4.3
f119_SB3_3_4	-39.33	4.5
f722_SB3_3_5	-44.67	4.5
f711_SB3_3_6	-38.00	4.4
f119_SB3_3_7	-39.00	5.8
Mean	-38.48	4.8
Minimum	-44.67	4.2
Maximum	-30.00	5.8

File	Rate of Change	Acceleration Magnitude at Gate (g)
f711_SB6_1_1	-75.67	11.9
f106_SB6_1_2	-77.00	7.6
f114_SB6_1_3	-79.00	8.3
f119_SB6_1_4	-71.67	8.7
f722_SB6_1_5	-75.67	8.5
f661_SB6_1_6	-79.00	7.5
f722_SB6_1_7	-72.00	7.4
f102_SB6_1_8	-72.33	8.4
f101_SB6_1_9	-74.67	6.9
f109_SB6_1_10	-70.67	6.9
f711_SB6_1_11	-68.67	7.4
f119_SB6_1_12	-71.67	10.2
f109_SB6_1_12	-74.00	7.3
f101_SB6_1_13	-68.33	8
f722_SB6_1_15	-72.33	7.1
f711_SB6_1_16	-75.67	6.2
f103_SB6_1_17	-75.00	10.4
Mean	-73.73	8.2
Minimum	-68.33	6.2
Maximum	-79.00	11.9

File	Rate of Change	Acceleration Magnitude at Gate (g)
f722_SB6_PT1	-44.67	3.8
F635_sb6_pt2	-43.00	4.3
f117_SB6_3_1	-40.33	4.6
f661_SB6_3_2	-43.00	4.1
f101_SB6_3_3	-39.00	4.7
f722_SB6_3_4	-45.00	4.1
f722_SB6_3_5	-41.33	4.3
f101_SB6_3_6	-42.33	4.1
f109_SB6_3_7	-40.33	4.4
f711_SB6_3_8	-34.33	4
f661_SB6_3_9	-42.67	3.8
f114_SB6_3_10	-43.00	4.6
f103_SB6_3_11	-36.00	5.9
f114_SB6_3_12	-39.33	4
f661_SB6_3_13	-39.33	3.4
f711_SB6_3_14	-41.33	4.6
f722_SB6_3_15	-37.67	4.3
f106_SB6_3_16	-37.00	3.2
f103_SB6_3_17	-35.67	5.7
f101_SB6_3_18	-39.00	4.5
F104_SB6_3_19	-46.00	4.9
f109_SB6_3_20	-40.33	4.4
f102_SB6_3_21	-39.33	4.7
f711_SB6_3_22	-41.33	4.2
f114_SB6_3_23	-36.00	3.5
f119_SB6_3_24	-39.00	5.5
Mean	-40.24	4.37
Minimum	-46.00	3.2
Maximum	-34.33	5.9

## **Turbine Passage**

File	Time (s)	AdjTime (s)	Acceleration Magnitude (g)	Event Type	Location
F694DDT1	66.826	0.142	146.7	Shear	Nadir (runner)
	66.706	0.022	141.8	Strike	Runner
	66.725	0.041	128.7	Strike	Runner
SF103DDT3	79.0475	-0.007	189.9	Shear	Runner
	79.1474	0.093	142.9	Strike	Runner
	79.076	0.0215	117	Strike	Runner
SF109_4	61.3345	-0.006	118.7	Strike	Runner
	61.3645	0.024	111.3	Shear	Runner
SF694_5	63.8125	0.0535	192.4	Shear	Runner
	63.79	0.031	130.5	Shear	Runner
	63.625	-0.134	117.4	Strike	Runner
	63.763	0.004	115.1	Shear	Runner
SF121_6	75.4415	0.021	122.9	Shear	Runner
	75.414	-0.0065	121	Shear	Runner
	67.6995	-7.721	98.8	Strike	Scroll case
SF103_7	62.91	-0.067	169.4	Strike	Runner
	62.897	-0.08	134.3	Strike	Runner
	63.002	0.025	114.3	Shear	Runner
	62.985	0.008	100.6	Shear	Runner
SF121_9	65.9425	0.0415	216.5	Shear	Runner
	66.3375	0.4365	190.1	Strike	Draft tube
	65.901	0	173.4	Shear	Runner
	65.9255	0.0245	163.1	Strike	Runner
	65.984	0.083	140	Shear	Runner
SF694_10	58.4815	0.0005	187	Strike	Runner
	58.5325	0.0515	166.4	Shear	Runner
	58.579	0.098	132.7	Strike	Runner
	58.5115	0.0305	120.2	Shear	Runner
	58.59	0.109	98.8	Shear	Runner
SF103_11	64.6595	-0.008	199.5	Shear	Runner
SF109_13	61.101	-0.0045	155.5	Shear	Runner
	61.129	0.0235	115.1	Shear	Runner
SF120_14	68.189	-0.1565	167.1	Strike	Runner
	68.2	-0.1455	128.4	Strike	Runner
	68.3935	0.048	122.8	Shear	Runner
	68.348	0.0025	121.6	Shear	Runner
	68.276	-0.0695	120.4	Strike	Runner

File	Time (s)	AdjTime (s)	Acceleration Magnitude (g)	Event Type	Location
Sf121_15	73.417	-0.013	222.4	Strike	Runner
	73.559	0.129	220.4	Strike	Runner
	73.5235	0.0935	205.4	Shear	Runner
	73.5435	0.1135	184.8	Shear	Runner
	73.6255	0.1955	154.5	Shear	Runner
	73.596	0.166	148.6	Strike	Runner
	73.4545	0.0245	148.3	Shear	Runner
SF103_16	68.513	0.0305	215.3	Shear	Runner
	68.535	0.0525	148.3	Shear	Runner
	68.4885	0.006	110.5	Shear	Runner
	68.5825	0.1	95.5	Shear	Runner
sf109_17	66.567	-0.0505	147.4	Strike	Runner
	66.6195	0.002	118.9	Strike	Runner
sf103_19	64.6935	0.044	225.3	Shear	Runner
	64.736	0.0865	165.8	Shear	Runner
	64.649	-0.0005	146.8	Shear	Runner
	64.7125	0.063	123.4	Shear	Runner
	64.7545	0.105	100.5	Shear	Runner
sf103_21	54.1995	0.035	234.8	Shear	Runner
	54.157	-0.0075	222.5	Strike	Runner
sf109_22	69.6785	0.0215	126.9	Strike	Runner
	69.652	-0.005	124	Shear	Runner
sf121_23	62.206	0.022	147.4	Shear	Runner
	62.1765	-0.0075	131.7	Shear	Runner
	62.272	0.088	119.6	Strike	Runner
sf109_24	70.6955	0.0695	168.2	Shear	Runner
	70.5815	-0.0445	128.4	Strike	Runner
	70.648	0.022	126.1	Shear	Runner
	70.718	0.092	108.4	Shear	Runner
	70.6275	0.0015	98.4	Shear	Runner
<b>Mean</b>	<b>All:</b>	<b>147.03</b>	<b>Most Severe:</b>	<b>Mean</b>	<b>176.49</b>
<b>Maximum</b>		<b>234.8</b>		<b>Maximum</b>	<b>234.8</b>
<b>Minimum</b>		<b>95.5</b>		<b>Minimum</b>	<b>118.7</b>
<b>SD</b>		<b>37.21</b>		<b>SD</b>	<b>36.49</b>
<b>SE</b>		<b>4.55</b>		<b>SE</b>	<b>8.37</b>



File Name	Rate of Change (psia/s)	Nadir (psia)
SF694DDT1	-739.6	1.23
SF103DDT3	-700	7.00
SF109_4	-773.4	8.71
SF694_5	-955.6	7.21
SF121_6	-678	9.35
SF103_7	-862	7.77
SF694_10	-1654.6	4.51
SF103_11	-903.2	9.62
SF121_9	-1455.6	0.95
SF109_13	-1512.4	6.36
SF120_14	-897.4	4.94
Sf121_15	-1226.4	2.15
SF103_16	-1442.8	6.58
sf109_17	-1057.2	7.97
sf103_19	-1315.6	6.78
sf103_21	-1472.2	8.25
sf109_22	-964.6	7.37
sf121_23	-1182.4	9.93
sf109_24	-1345.2	0.93
Mean	-1112.54	6.19
Min	-678	0.93
Max	-1654.6	9.93
StDev	310.8	2.94
Std Err	71.3	0.68

## **Regulating Outlet Passage**

File	Time (s)	AdjTime (s)	Acceleration Magnitude (g)	Event Type	Location
f103_1_1	37.8315	5.421	126.9	Shear	Plunge
	32.5375	0.127	117.6	Strike	Conduit – behind gate
	35.1465	2.736	110.5	Strike	Conduit
	32.5875	0.177	106.3	Strike	Conduit – behind gate
f923_1_2	34.8105	1.5085	115.1	Strike	Conduit
	34.516	1.214	113.9	Strike	Conduit
	38.2735	4.9715	109.4	Shear	SB
	38.237	4.935	108.8	Strike	Plunge
f121_1_3	32.8745	5.018	153	Shear	Plunge
	28.001	0.1445	123.6	Strike	Conduit – behind gate
	28.195	0.3385	106.1	Strike	Conduit
f109_1_4	29.341	0.2305	157.4	Strike	Conduit – behind gate
	34.746	5.6355	124.9	Shear	Plunge
	34.72	5.6095	114.2	Strike	Air
f930_1_5	32.1885	5.378	130.4	Shear	Plunge
	27.1325	0.322	109.3	Strike	Conduit
f931_1_6	33.4325	5.5365	137.3	Shear	Plunge
	28.086	0.19	107.7	Strike	Conduit – behind gate
f908_1_7	30.9115	0.968	131.9	Strike	Conduit
	32.552	2.6085	131.5	Strike	Conduit – exit
	30.3515	0.408	130.2	Strike	Conduit – behind gate
	31.16	1.2165	117.7	Strike	Conduit
	35.22		108.2	Shear	Plunge
f930_1_8	33.7455	5.1455	142.8	Shear	Plunge
	28.6725	0.0725	115.7	Strike	Conduit – behind gate
f121_1_9	34.413	5.4305	131.3	Shear	Plunge
	29	0.0175	107.6	Strike	Conduit – behind gate
	29.0825	0.1	104.5	Strike	Conduit – behind gate
f923_1_10	35.8515	5.523	180.6	Shear	Plunge
	32.643	2.3145	97.6	Strike	Conduit
f109_1_11	35.935	5.6335	165	Shear	Plunge
	30.396	0.0945	139.9	Strike	Conduit – behind gate
	36.0415	5.74	108	Strike	SB
f930_1_12	33.1245	5.0355	143.5	Shear	Plunge
	28.13	0.041	117.4	Strike	Conduit – behind gate
	28.9045	0.8155	108.8	Strike	Conduit
	28.3985	0.3095	101.3	Strike	Conduit
f931_1_13	38.7985	5.6225	148.9	Shear	Plunge
f121_1_14	37.4195	5.085	139.8	Shear	Plunge
	32.362	0.0275	120	Strike	Conduit – behind gate

File	Time (s)	AdjTime (s)	Acceleration Magnitude (g)	Event Type	Location
f913_1_15	31.9035	2.776	134.2	Strike	Conduit
	34.2295	5.102	126.2	Shear	Plunge
	29.297	0.1695	114.1	Strike	Conduit – behind gate
	29.2735	0.146	97.7	Strike	Conduit – behind gate
f914_1_16	29.2685	0	113.4	Shear	Gate
	29.522	0.2535	110.8	Strike	Conduit
f932_1_17	28.332	0.187	155.1	Strike	Conduit – behind gate
	30.771	2.626	107.1	Strike	Conduit
	33.6225	5.4775	106.5	Shear	SB
	33.5235	5.3785	106.2	Strike	Plunge
	31.105	2.96	101.6	Strike	Conduit
<b>Mean</b>	<b>All:</b>	<b>122.30</b>	<b>Most Severe:</b>	<b>Mean</b>	<b>141.56</b>
<b>Maximum</b>		<b>180.6</b>		<b>Maximum</b>	<b>180.6</b>
<b>Minimum</b>		<b>97.6</b>		<b>Minimum</b>	<b>113.4</b>
<b>SD</b>		<b>18.64</b>		<b>SD</b>	<b>17.33</b>
<b>SE</b>		<b>2.61</b>		<b>SE</b>	<b>4.20</b>
f931_5_1	23.1065	4.092	151.8	Shear	Plunge
	21.1315	2.117	100.7	Strike	Conduit exit
f924_5_2	45.5225	4.452	148.3	Strike	SB
f932_5_3	50.6685	4.3395	172.4	Shear	SB
f913_5_4	24.636	4.3715	143.8	Shear	Plunge
f908_5_5	23.4035	2.3435	139.6	Strike	Conduit
	25.431	4.371	124.2	Strike	Plunge
f914_5_6	23.665	4.664	121.6	Strike	SB
f923_5_7	22.486				
f924_5_8	25.8925	2.1145	149.3	Strike	Conduit
f103_5_9	27.179	4.4295	151	Strike	SB
	26.8135	4.064	120	Shear	Plunge
f913_5_10	29.052	4.1835	140.6	Shear	Plunge
f914_5_11	45.038	4.073	133.9	Shear	Plunge
f103_5_12	26.0275	4.6365	103.5	Shear	Plunge
	23.5055	2.1145	101.7	Strike	Conduit
f908_5_13	36.806	1.1425	175.9	Strike	Conduit
	40.2025	4.539	140.1	Shear	Plunge
	38.2355	2.572	110.2	Strike	Conduit
f923_5_14	35.7505	4.13	135.8	Shear	Plunge
	33.8295	2.209	115.1	Strike	Conduit
f930_5_15	26.043	4.053	137.1	Shear	Plunge
	26.2775	4.2875	117.5	Shear	SB
	26.2125	4.2225	102.7	Shear	SB
	26.335	4.345	95.5	Shear	SB
f931_5_16	34.888				

File	Time (s)	AdjTime (s)	Acceleration Magnitude (g)	Event Type	Location
f109_5_17	24.555	2.435	130.1	Strike	Conduit
	26.585	4.465	129	Shear	Plunge
	24.4795	2.3595	103.9	Strike	Conduit
f908_5_18	33.1455	4.3875	147.5	Shear	Plunge
f121_5_19	28.284	3.934	168.4	Shear	Plunge
<b>Mean</b>	<b>All:</b>	<b>131.42</b>	<b>Most Severe:</b>	<b>Mean</b>	<b>144.15</b>
<b>Maximum</b>		<b>175.9</b>		<b>Maximum</b>	<b>175.9</b>
<b>Minimum</b>		<b>95.5</b>		<b>Minimum</b>	<b>103.5</b>
<b>SD</b>		<b>22.20</b>		<b>SD</b>	<b>17.98</b>
<b>SE</b>		<b>4.12</b>		<b>SE</b>	<b>4.36</b>

FILE	Acceleration Magnitude under Gate (g)	Pressure Rate of Change
f103_1_1	55.1	-909.00
f923_1_2	63.7	-941.00
f121_1_3	67.5	-980.67
f109_1_4	48.9	-970.00
f930_1_5	47.2	-952.33
f931_1_6	53.9	-924.67
f908_1_7	64.4	-937.33
f930_1_8	48.9	-942.00
f121_1_9	65	-1047.00
f923_1_10	54.3	-941.33
f109_1_11	47.2	-966.67
f930_1_12	50.4	-918.33
f931_1_13	52	-928.00
f121_1_14	61.9	-914.00
f913_1_15	53.6	-908.00
f914_1_16	113.4	-980.67
f932_1_17	53.8	-895.00
Mean	58.89	-944.47
Minimum	47.20	-1047.00
Maximum	113.40	-895.00

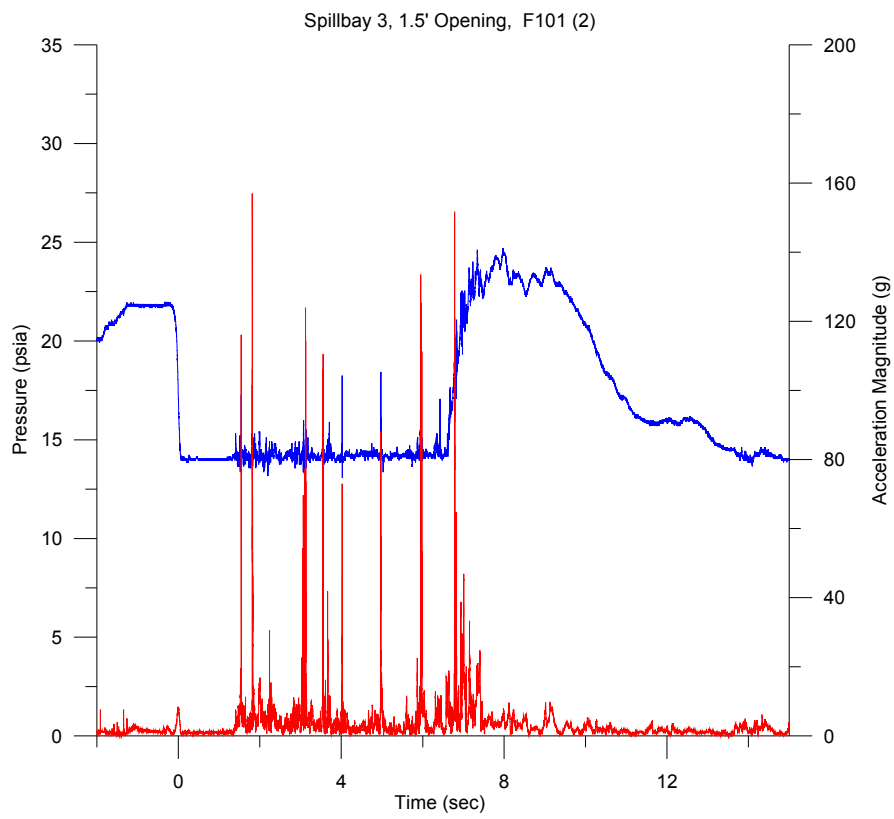
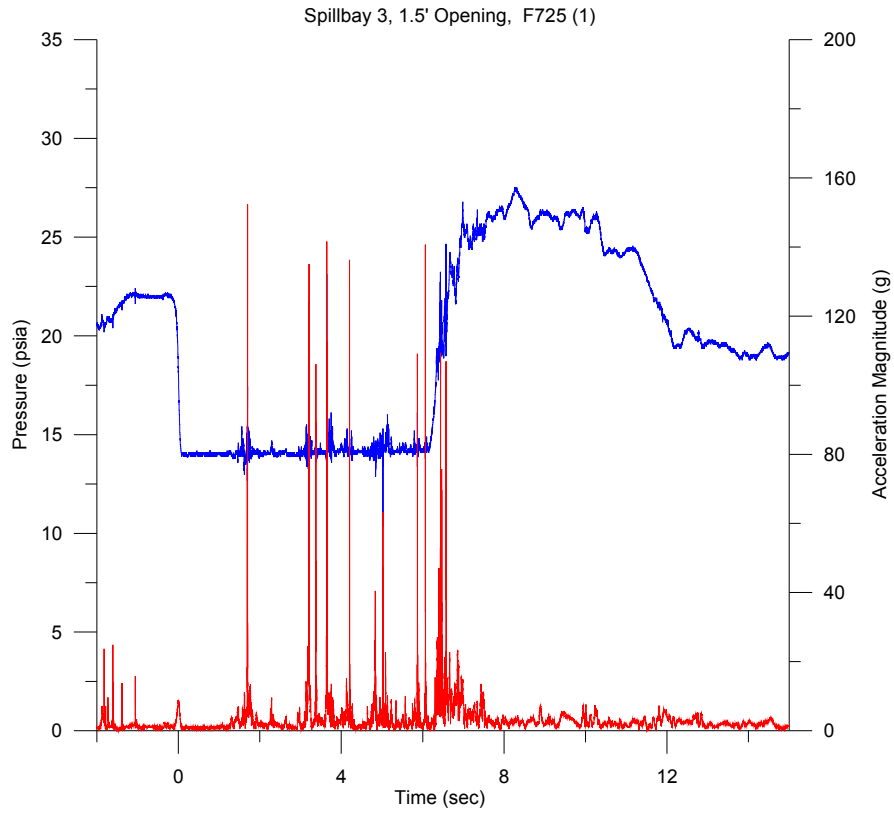
FILE	Acceleration Magnitude under Gate (g)	Pressure Rate of Change
f931_5_1	13.8	-235.33
f924_5_2	13	-205.00
f932_5_3	13.2	-216.33
f913_5_4	17.4	-305.67
f908_5_5	11.7	-185.00
f914_5_6	19.3	-283.33
f923_5_7	18.3	-391.67
f924_5_8	12.7	-189.00
f103_5_9	15	-257.33
f913_5_10	15.9	-314.67
f914_5_11	20.3	-338.67
f103_5_12	27.9	-371.67
f908_5_13	14.5	-260.00
f923_5_14	13.1	-256.67
f930_5_15	11.6	-230.67
f931_5_16	14	-275.00
f109_5_17	13.4	-268.67
f908_5_18	14.4	-273.67
f121_5_19	20.3	-312.33
Mean	15.78	-272.14
Minimum	11.60	-391.67
Maximum	27.9	-185.00

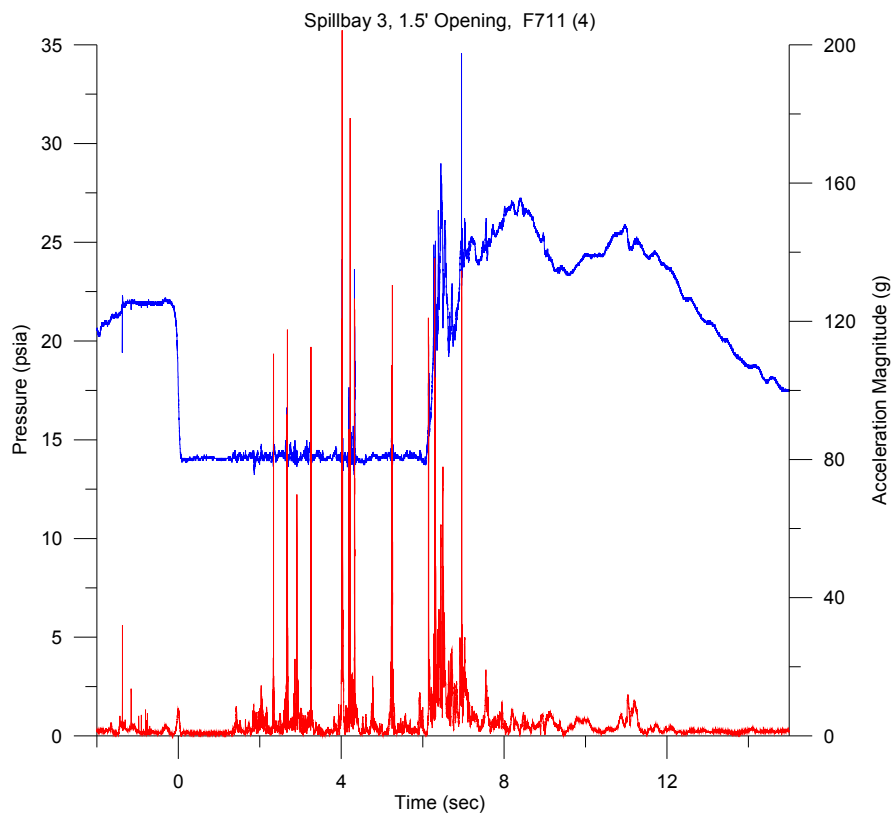
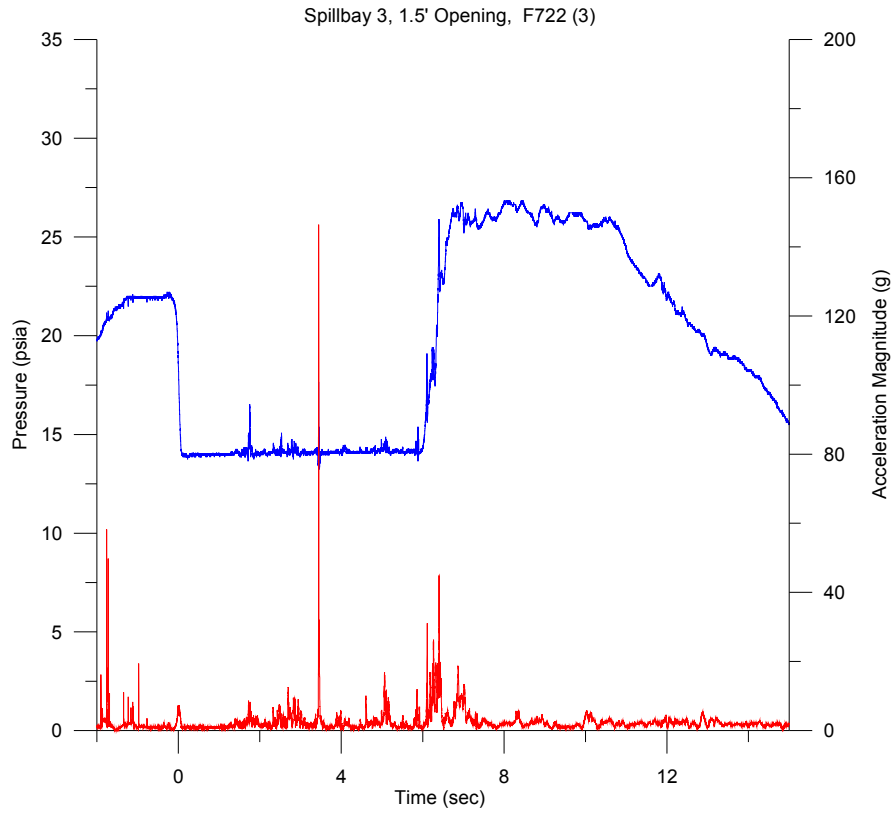
## **Appendix C**

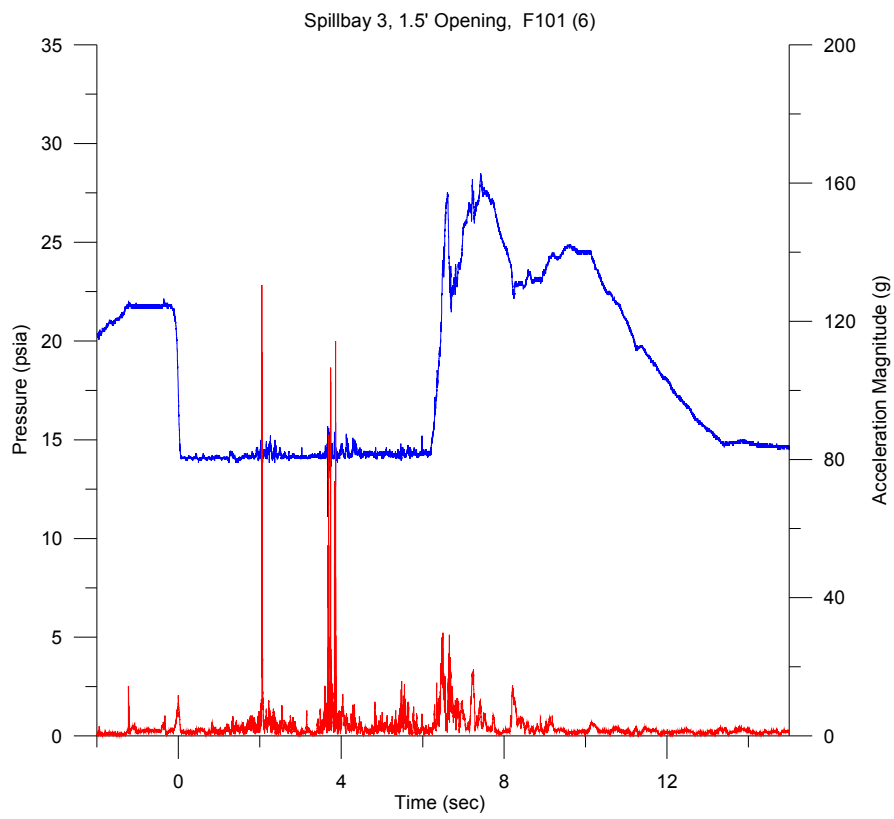
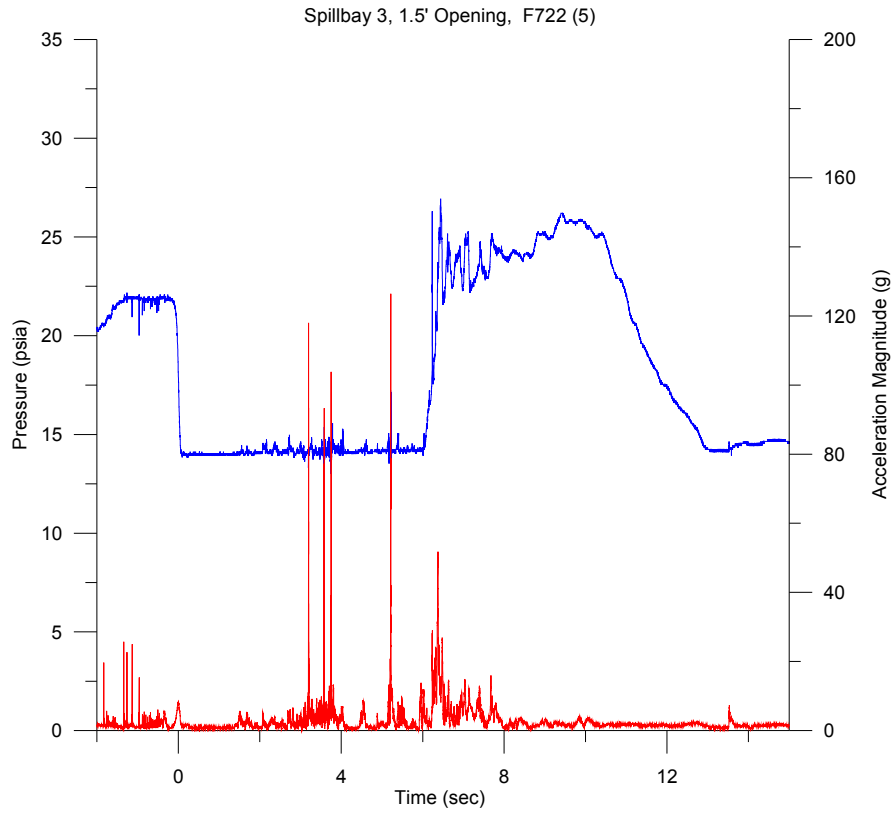
### **Pressure and Acceleration Magnitude Time Histories of Each Sensor Fish Release**

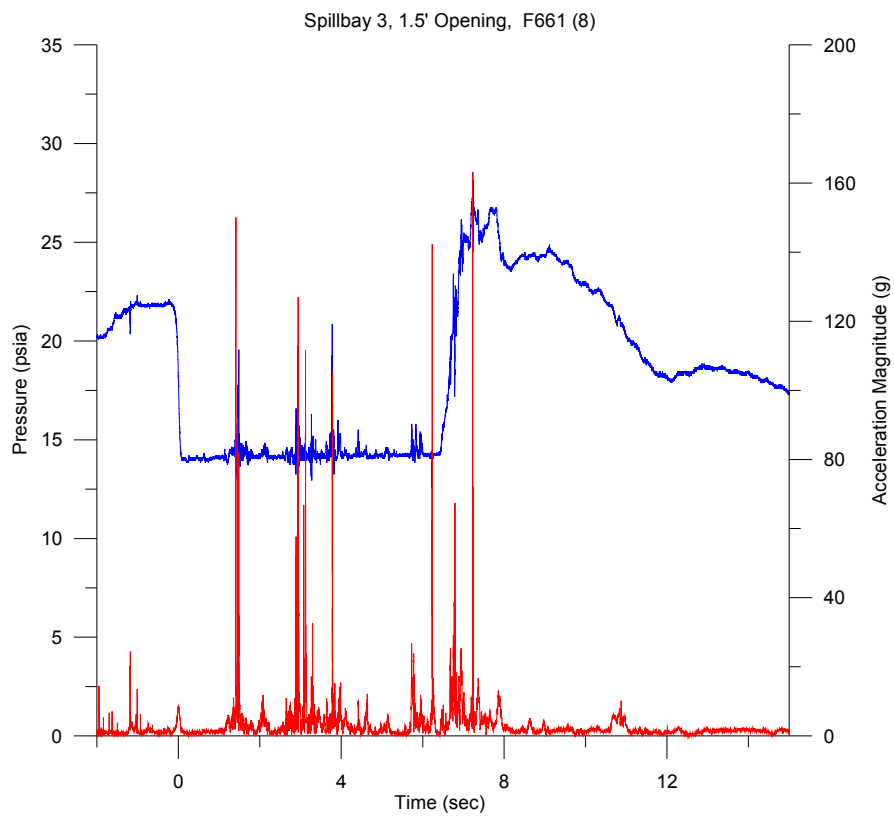
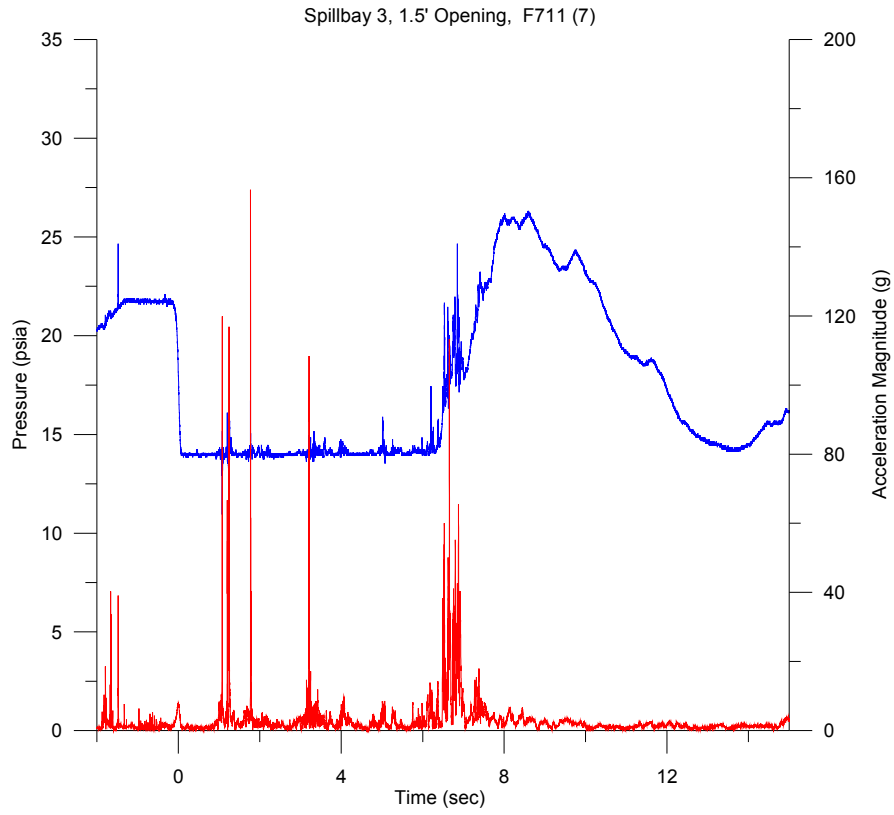


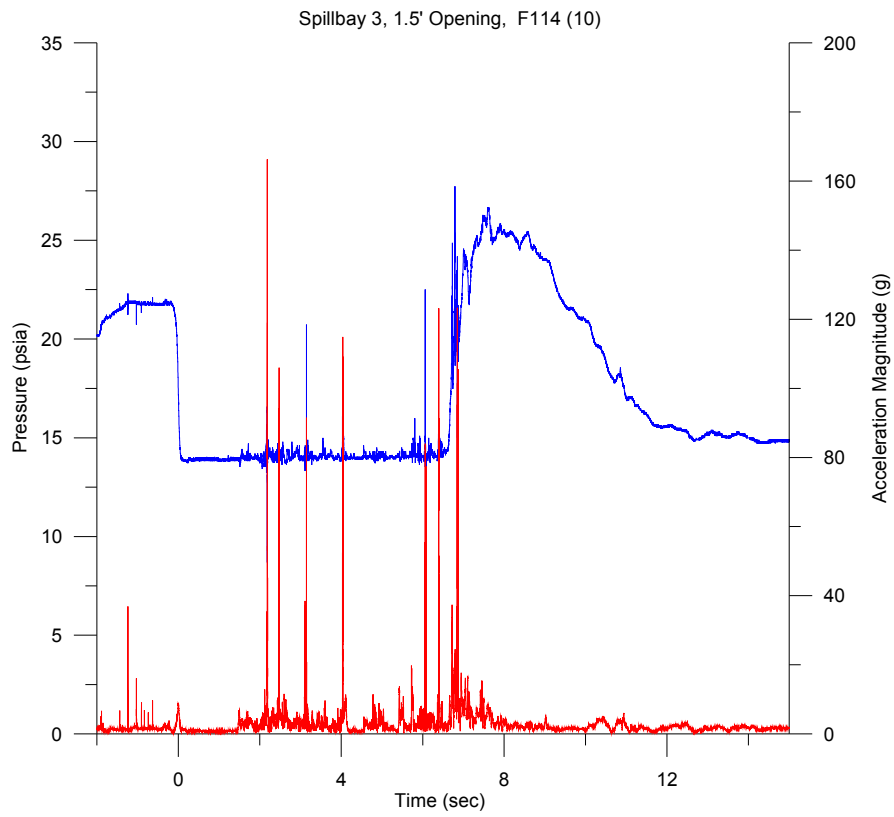
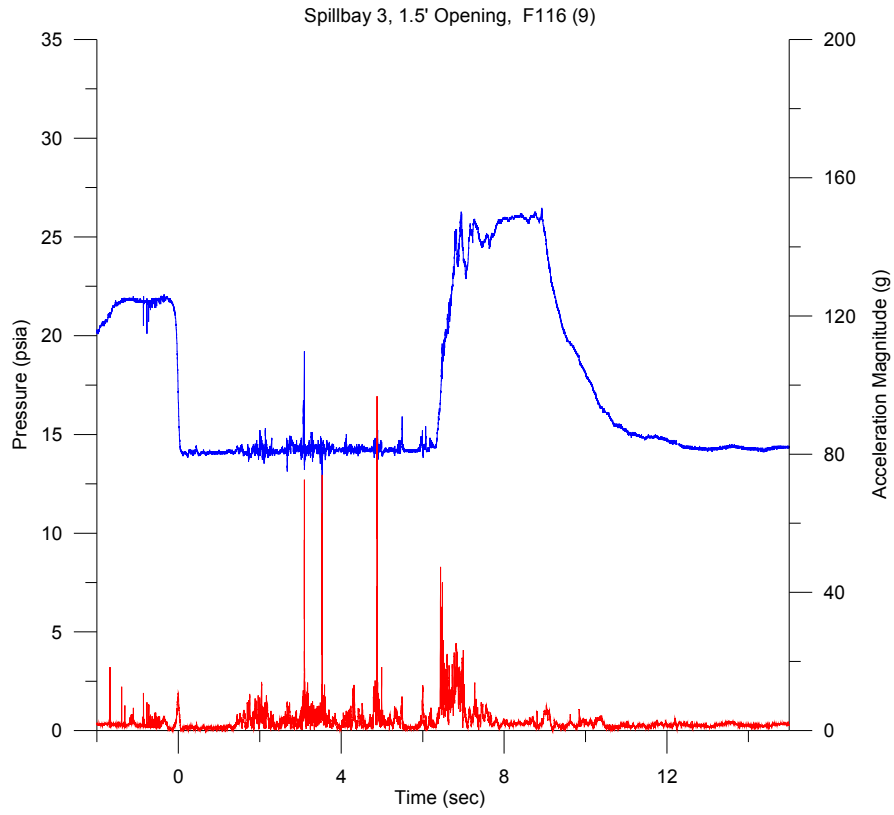
**Detroit Dam Spillway Evaluation**  
**Spillbay 3, 1.5-ft Gate Opening**

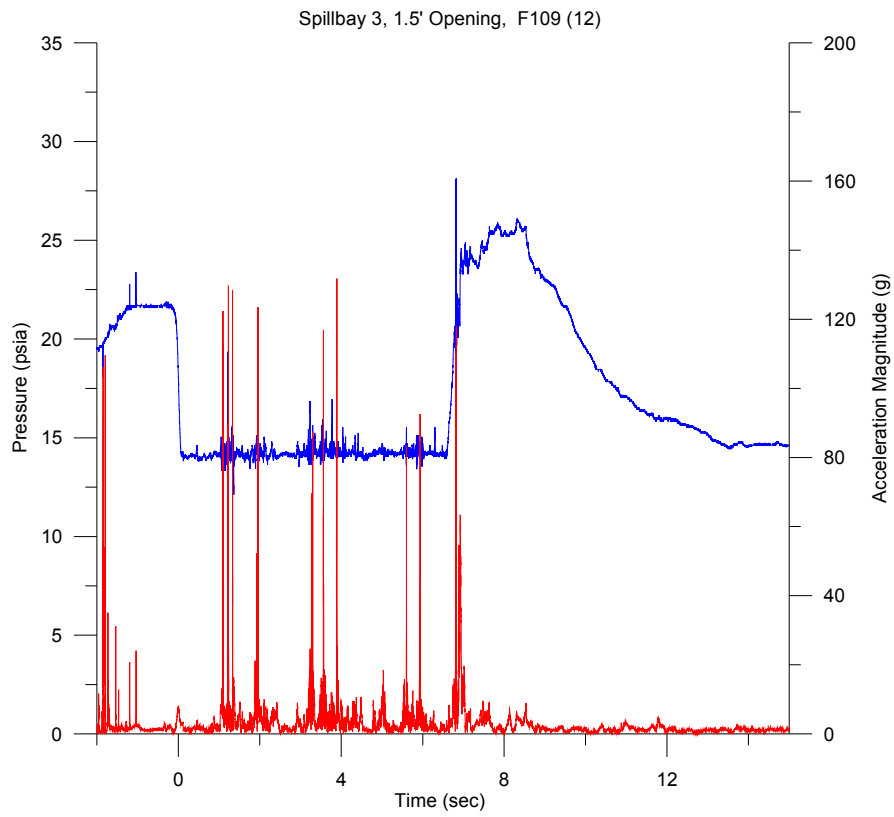
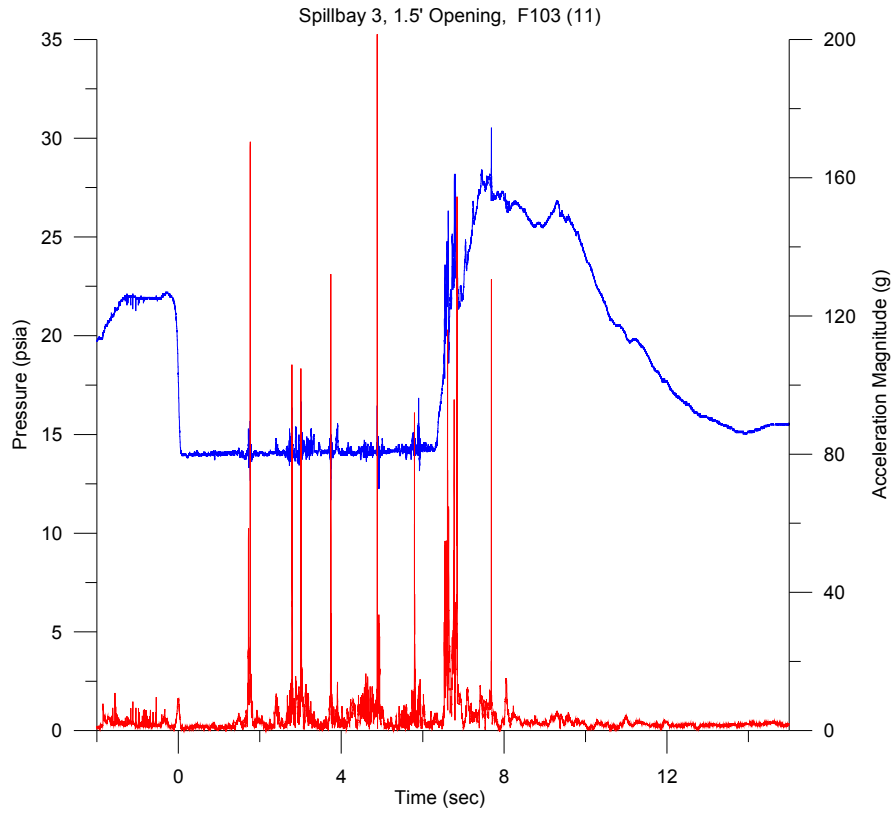


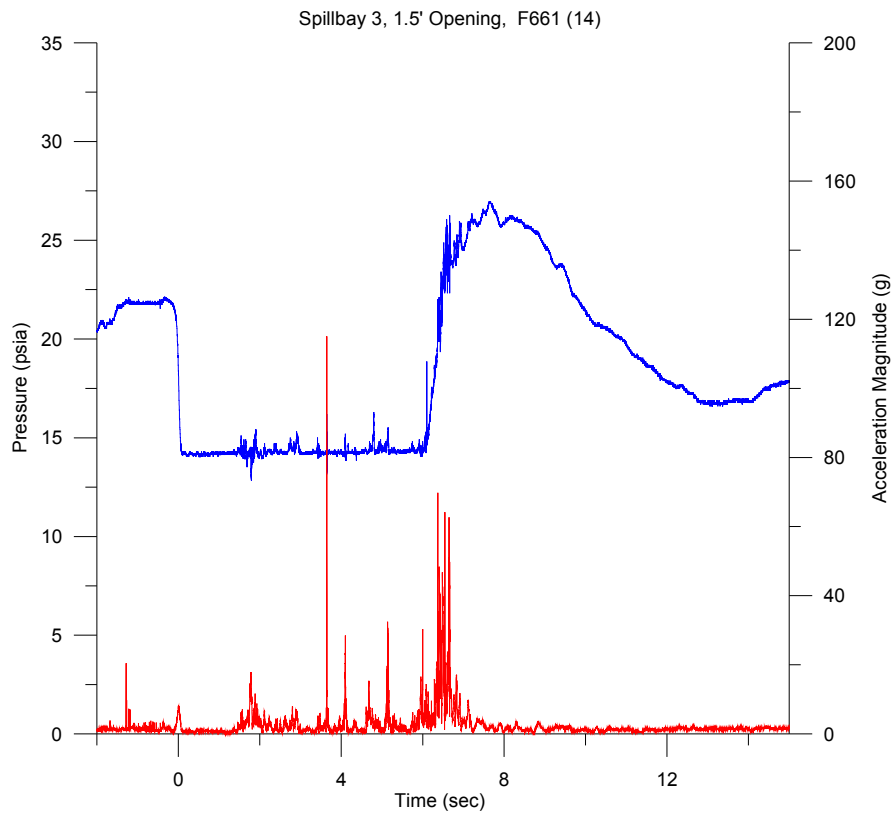
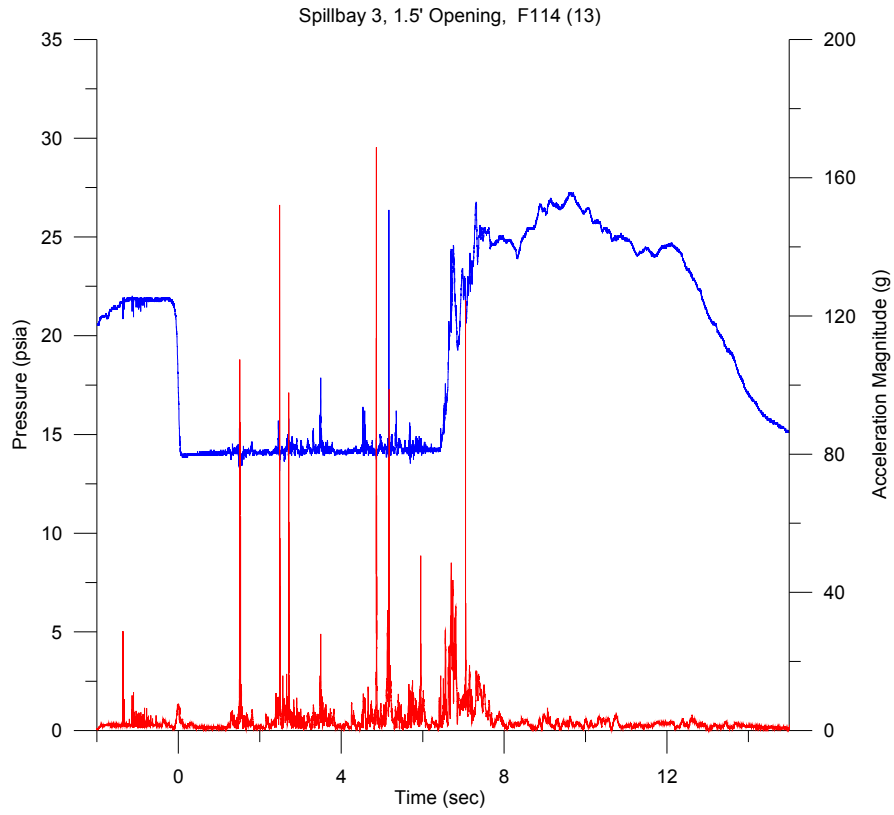




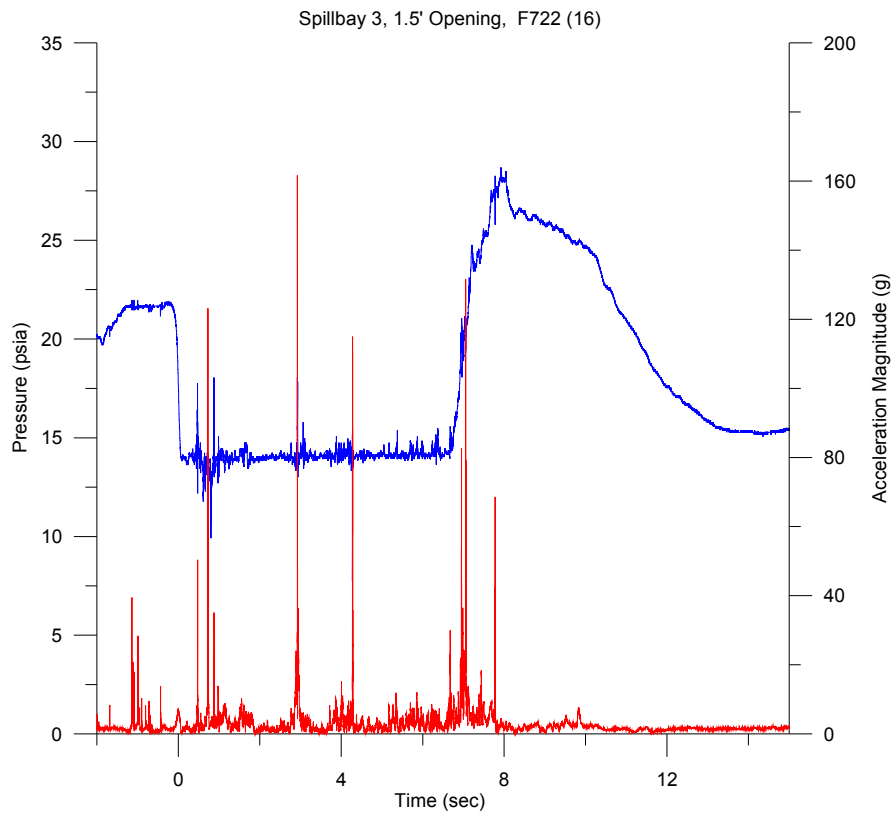
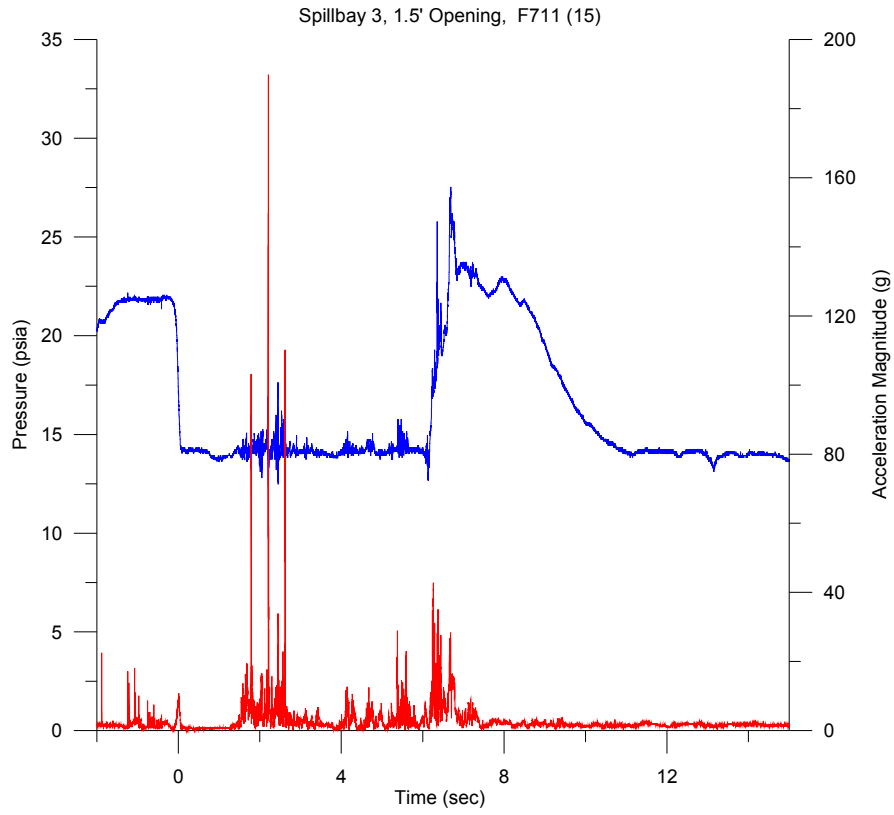


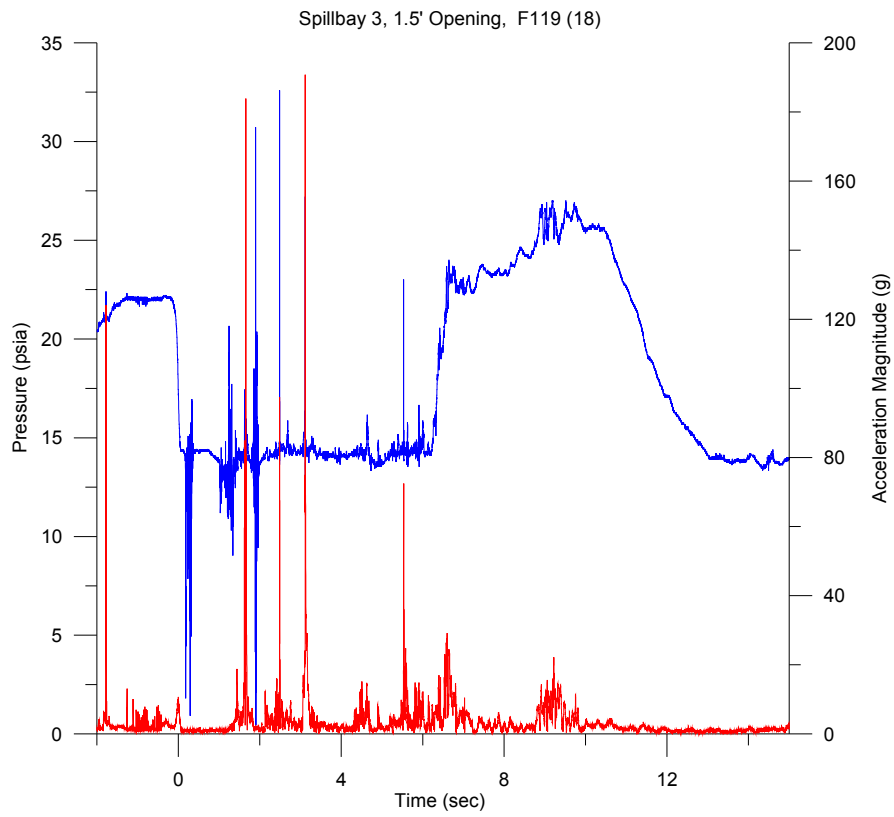
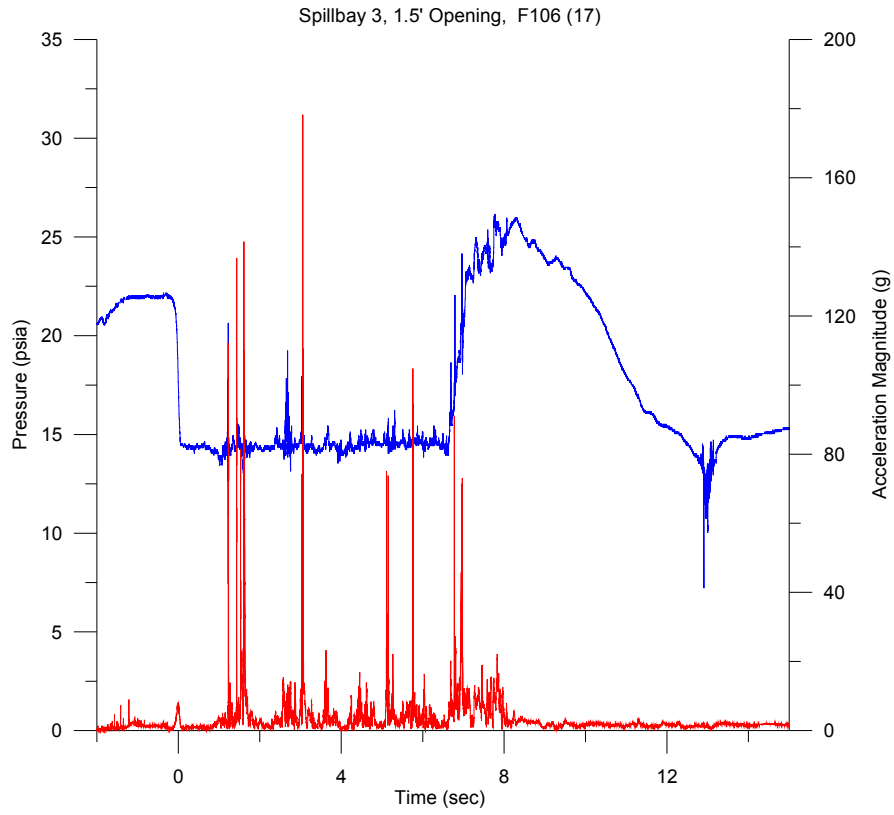


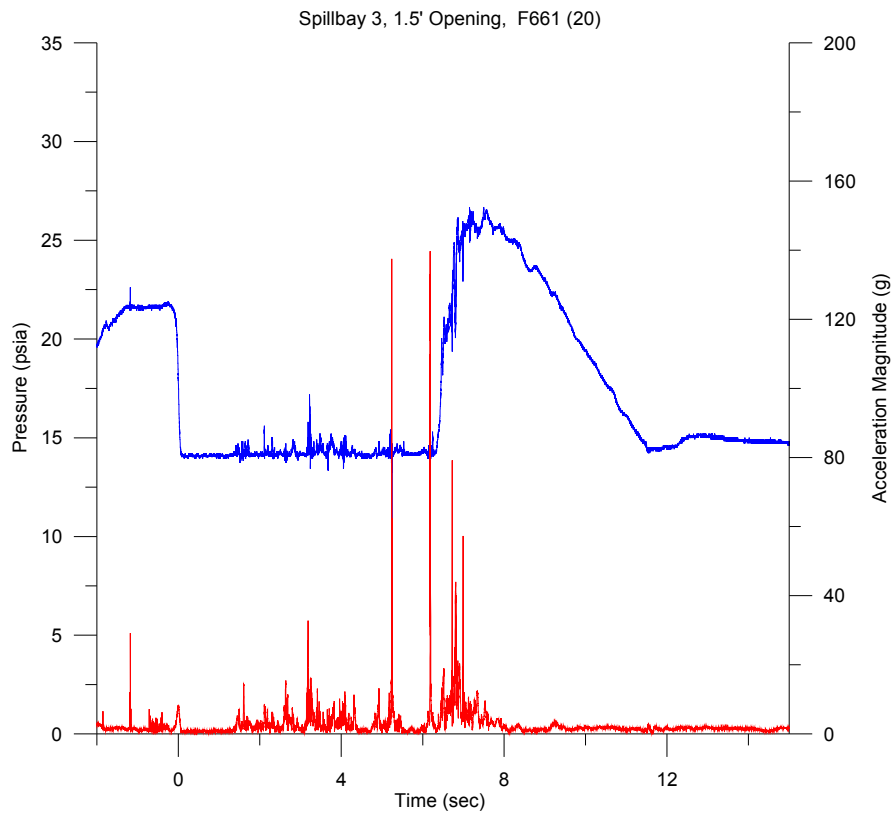
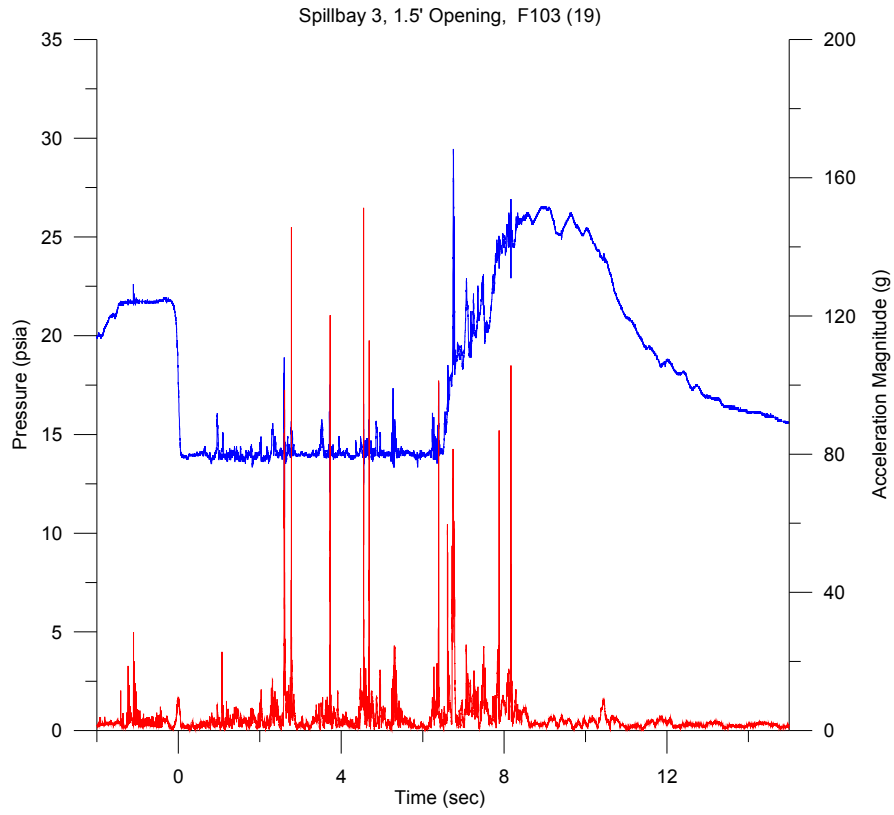


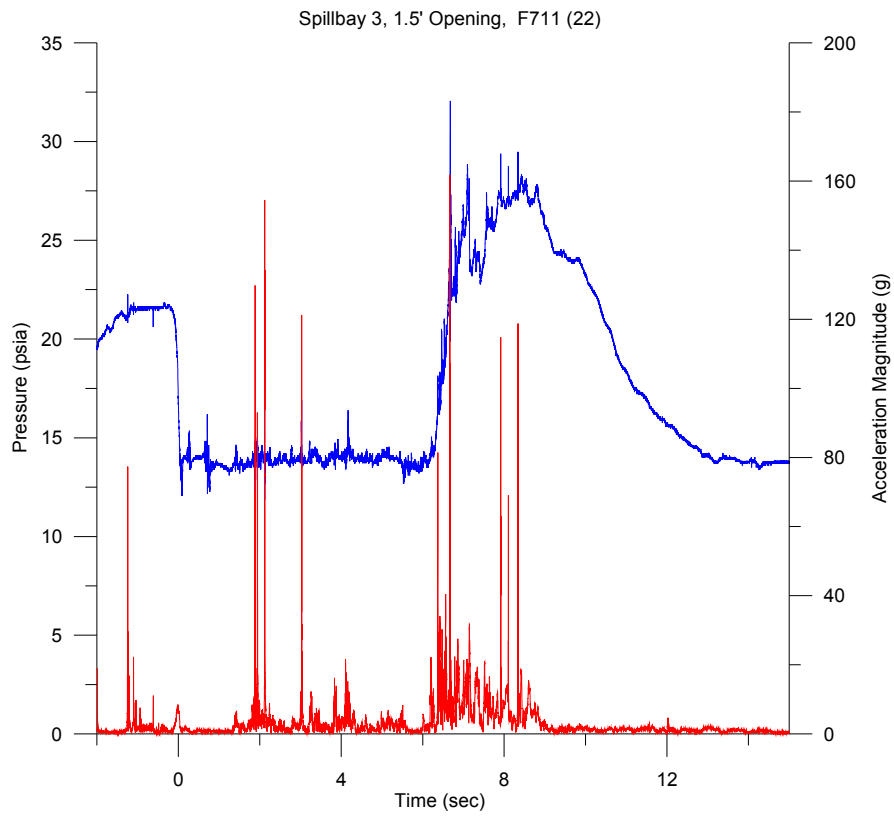
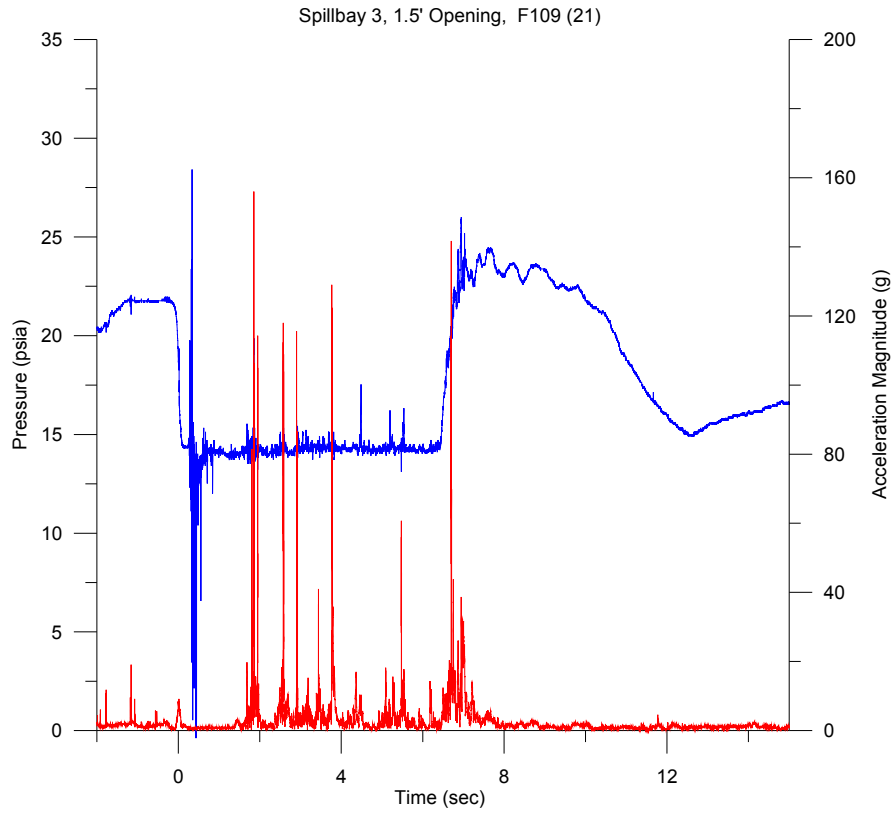


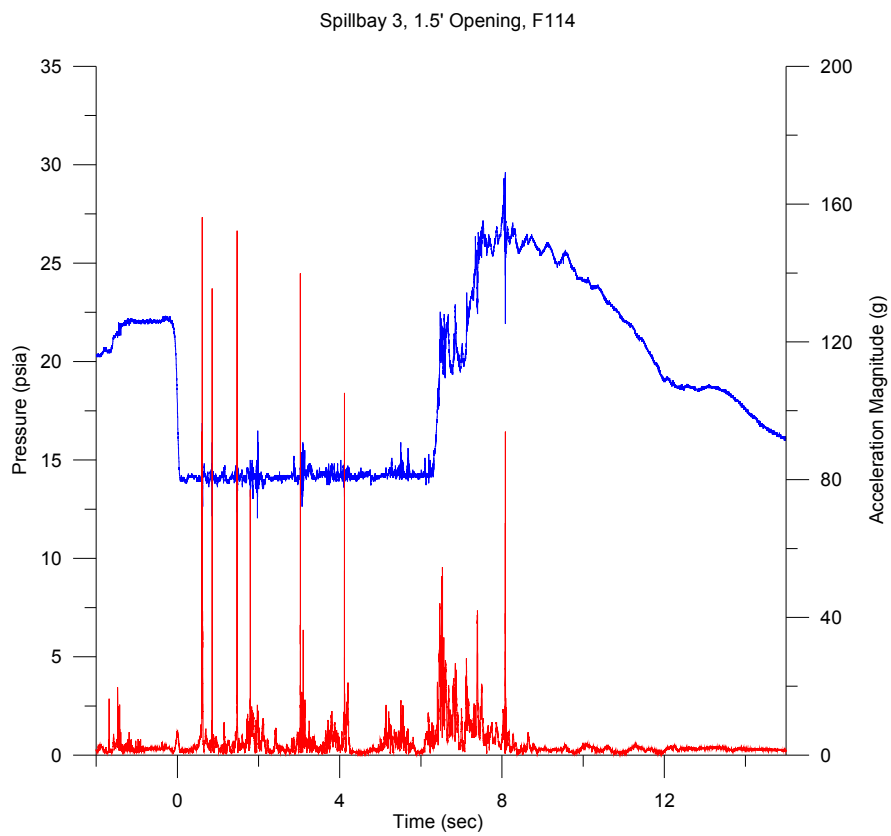
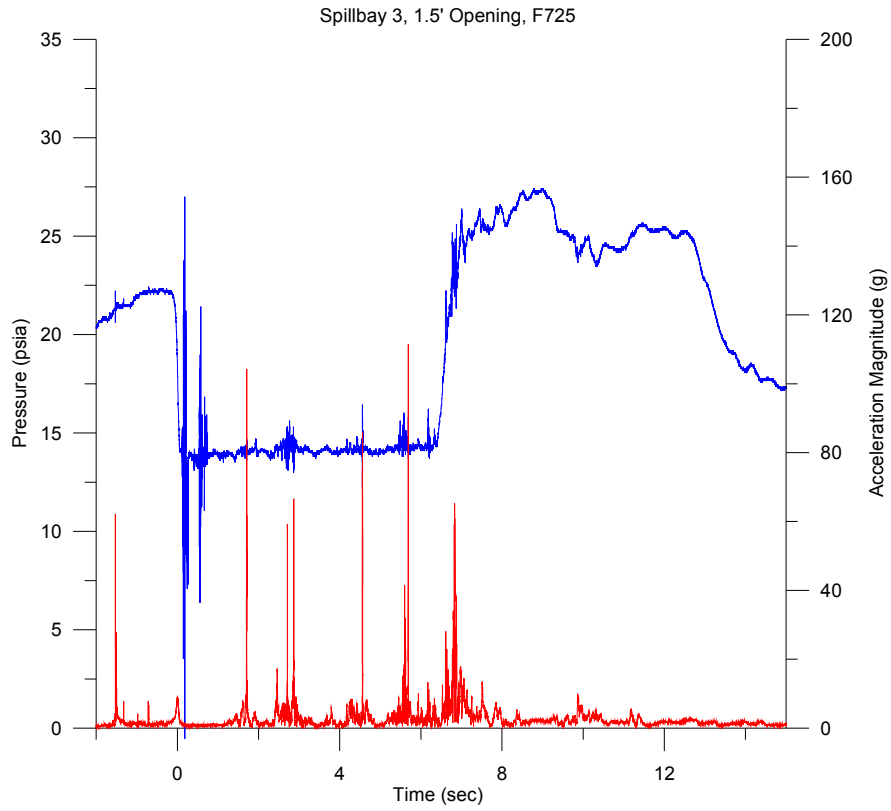




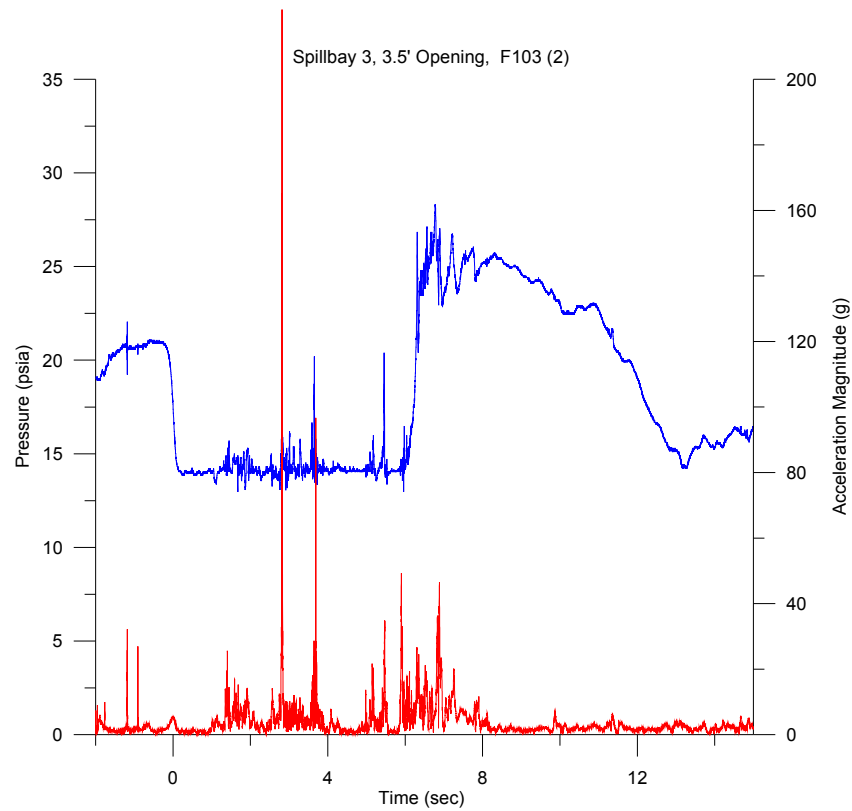
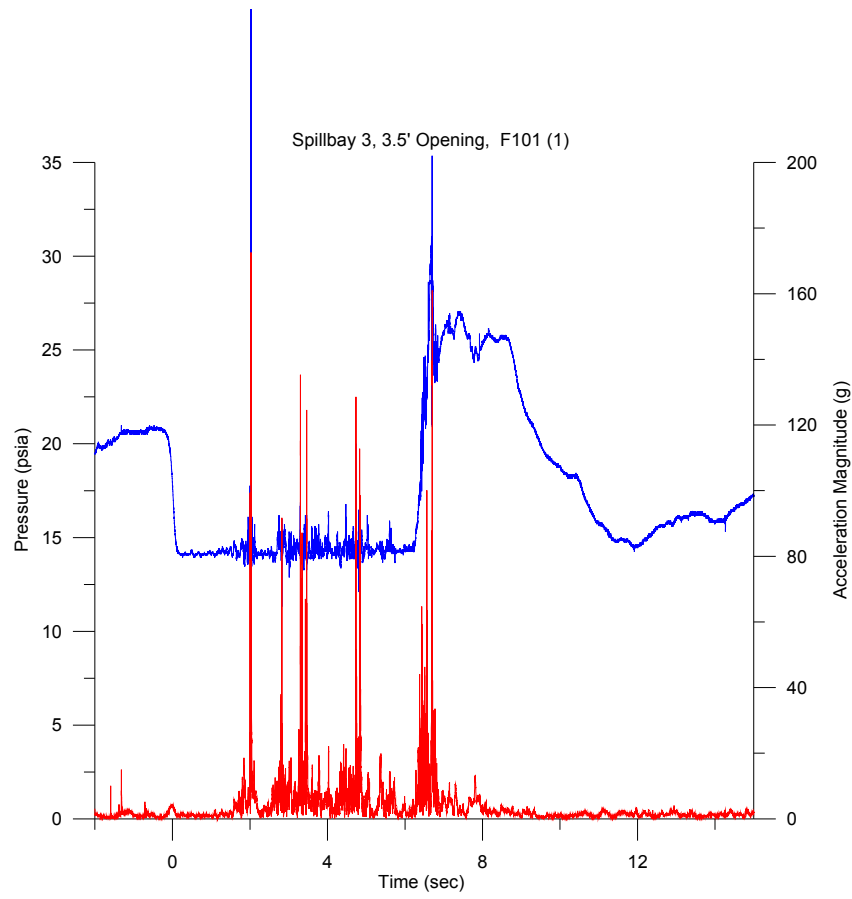


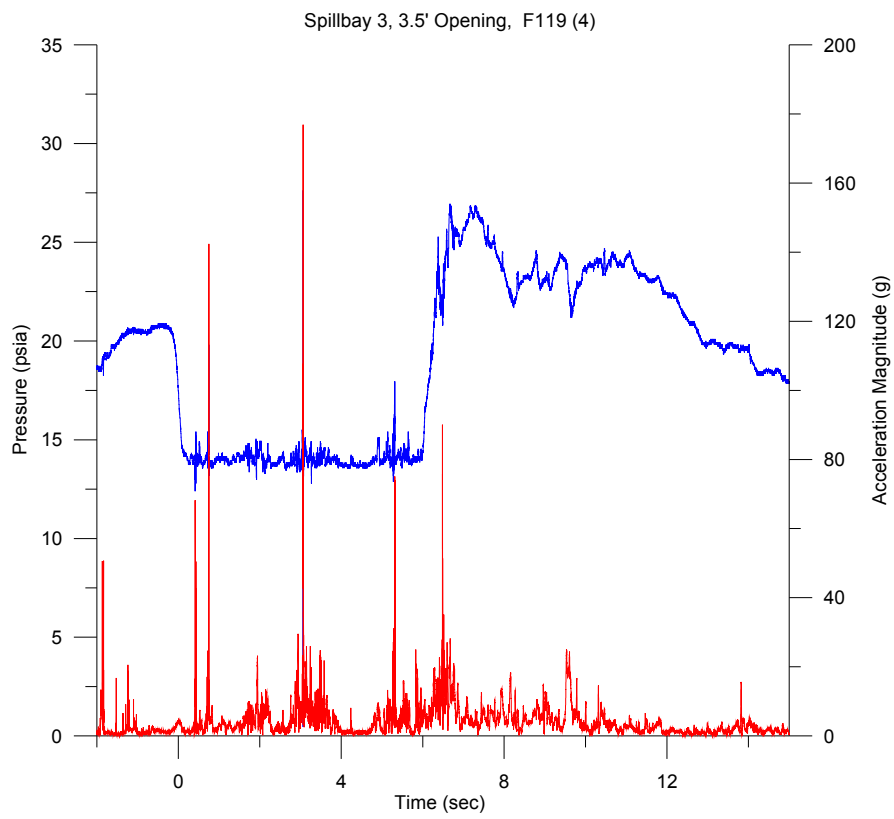
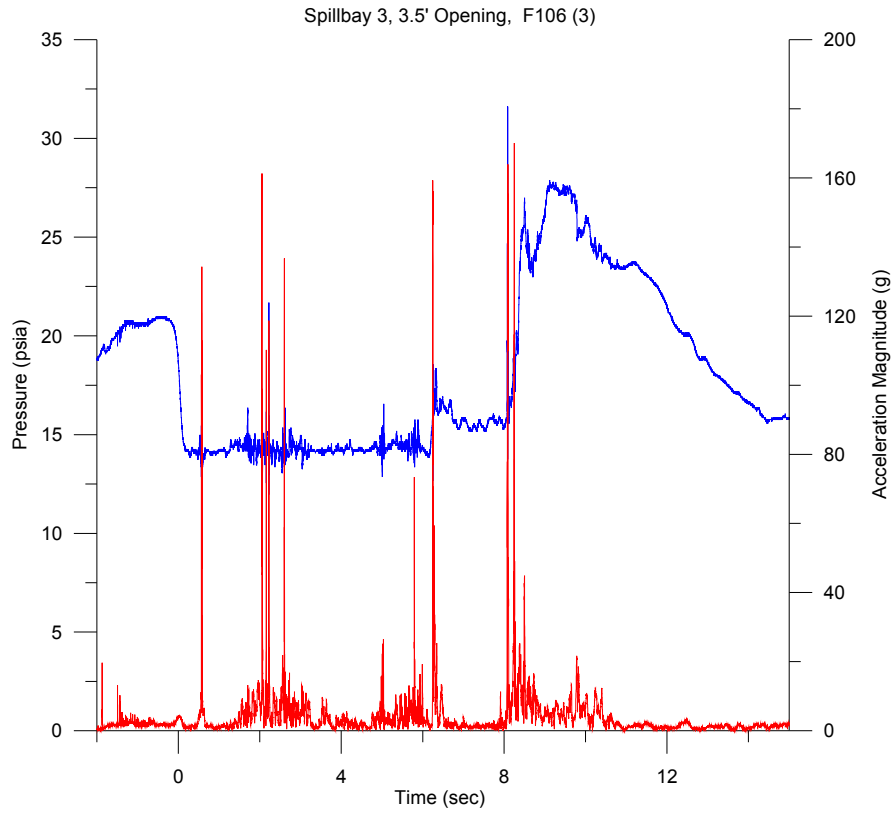




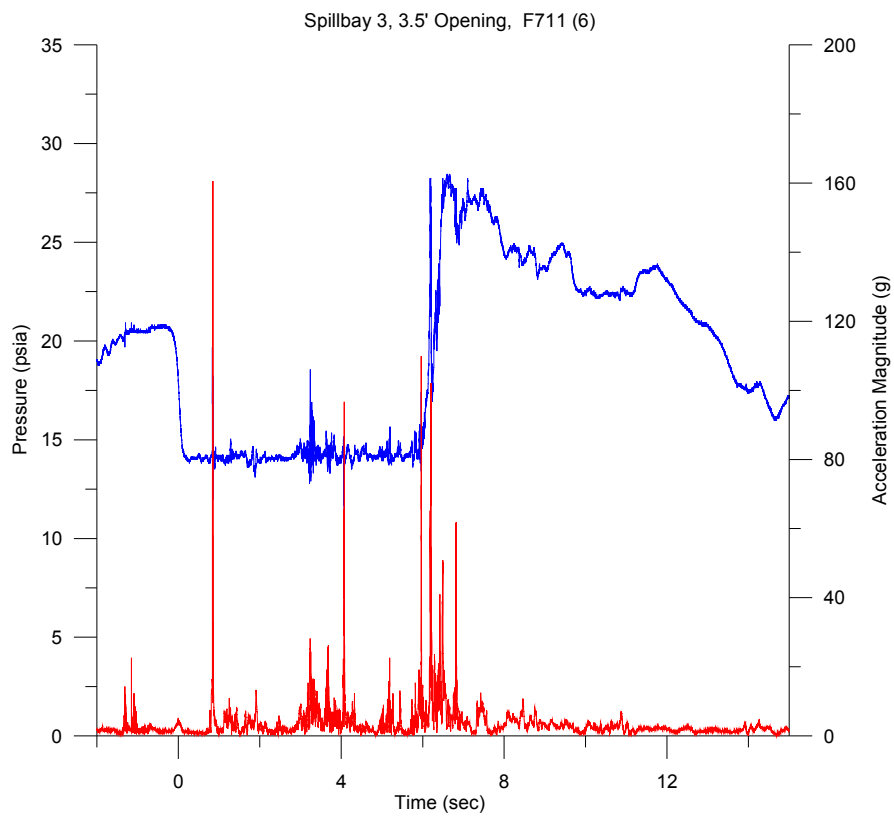
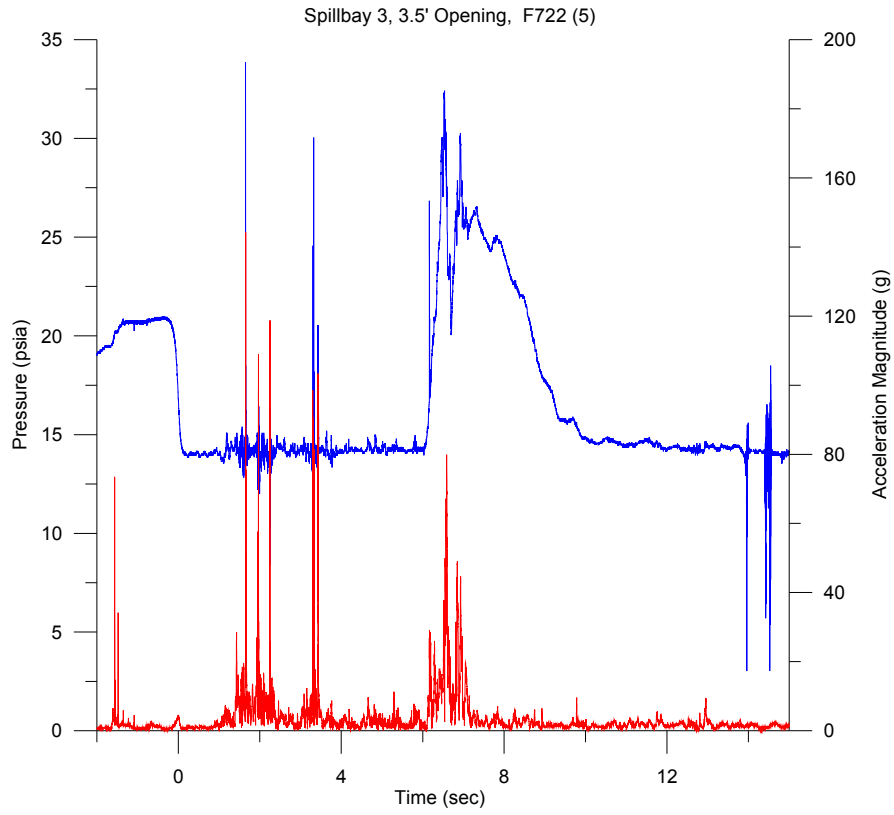


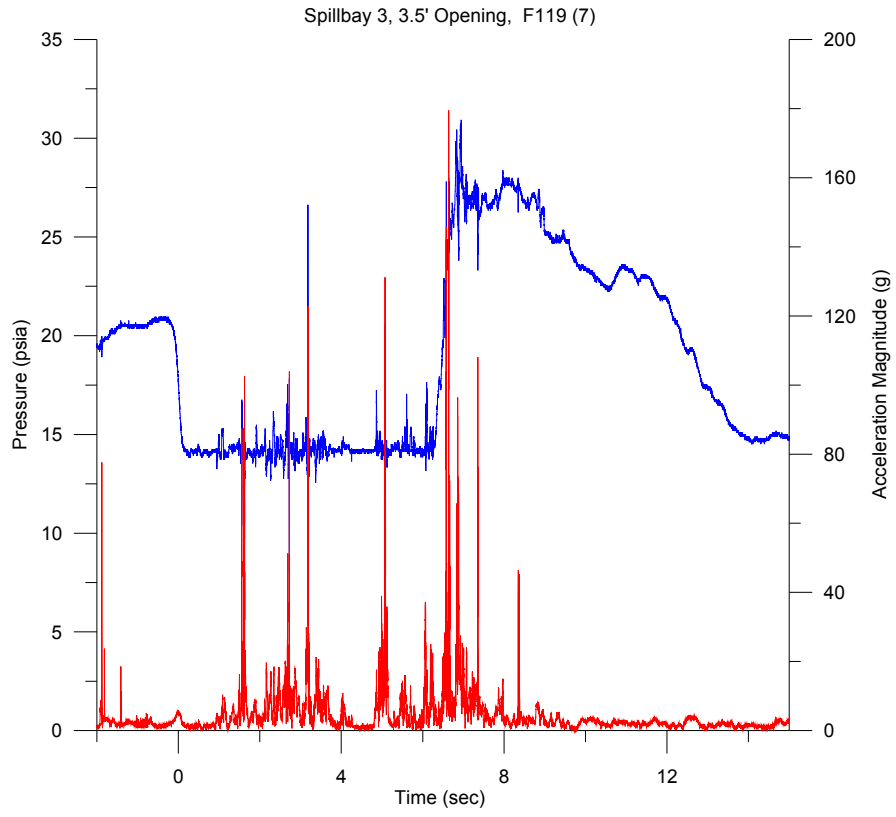
**Detroit Dam Spillway Evaluation**  
**Spillbay 3, 3.5-ft Gate Opening**





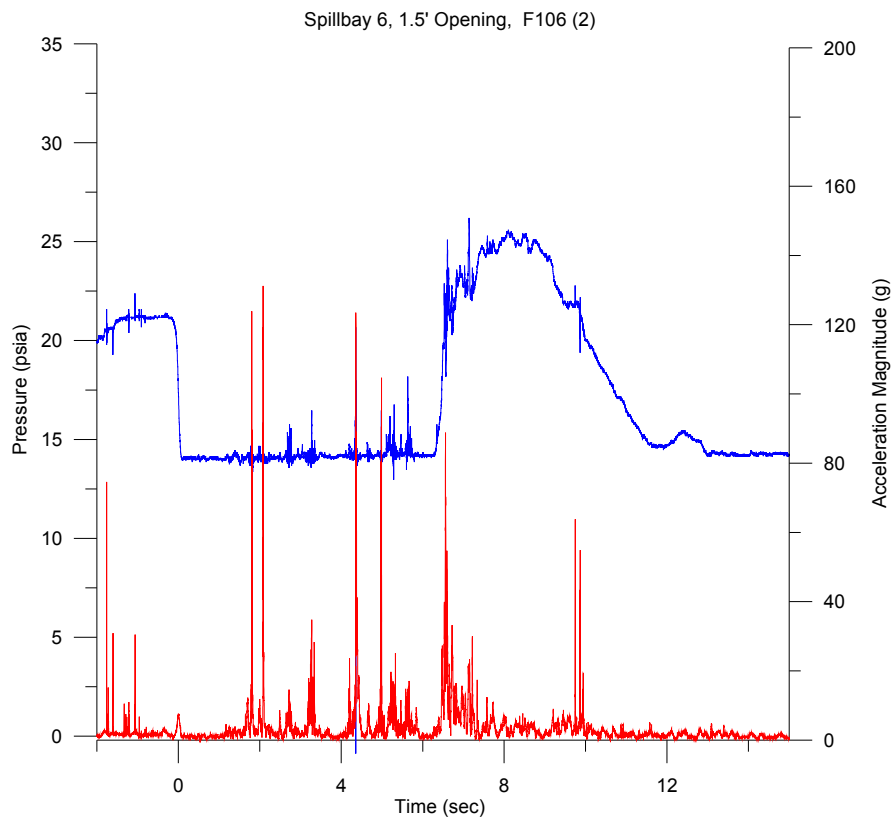
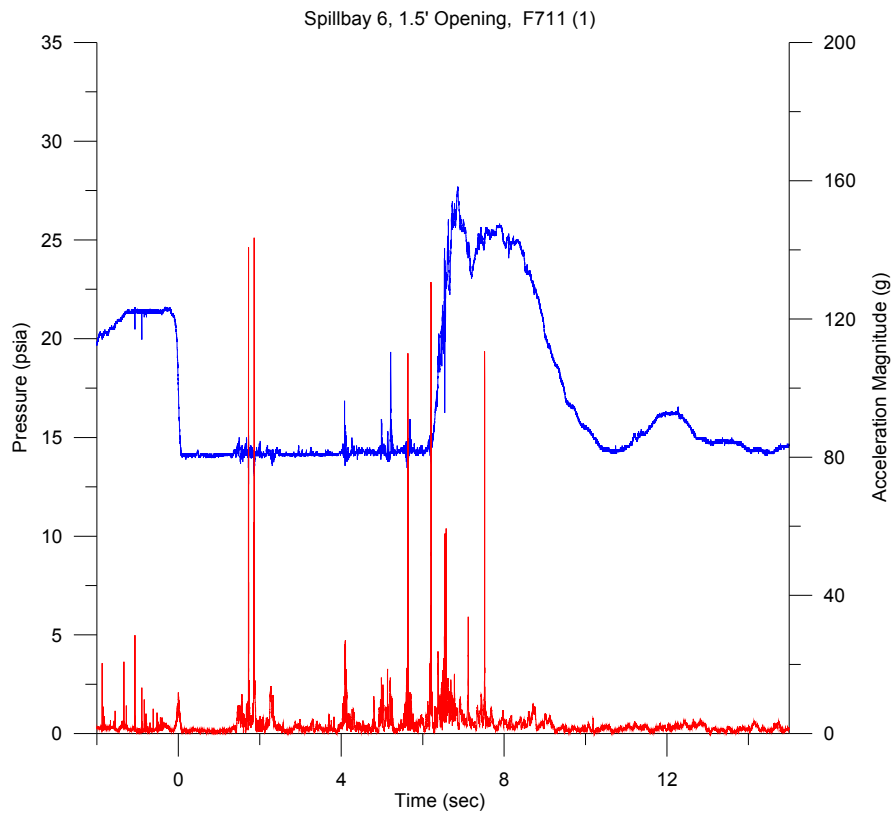


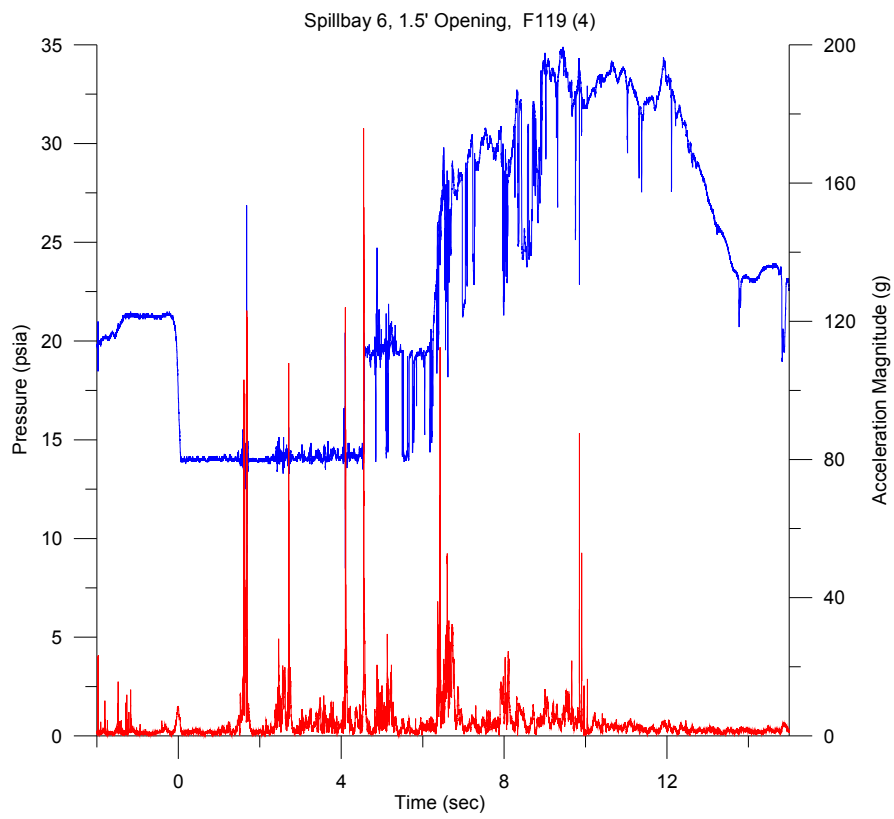
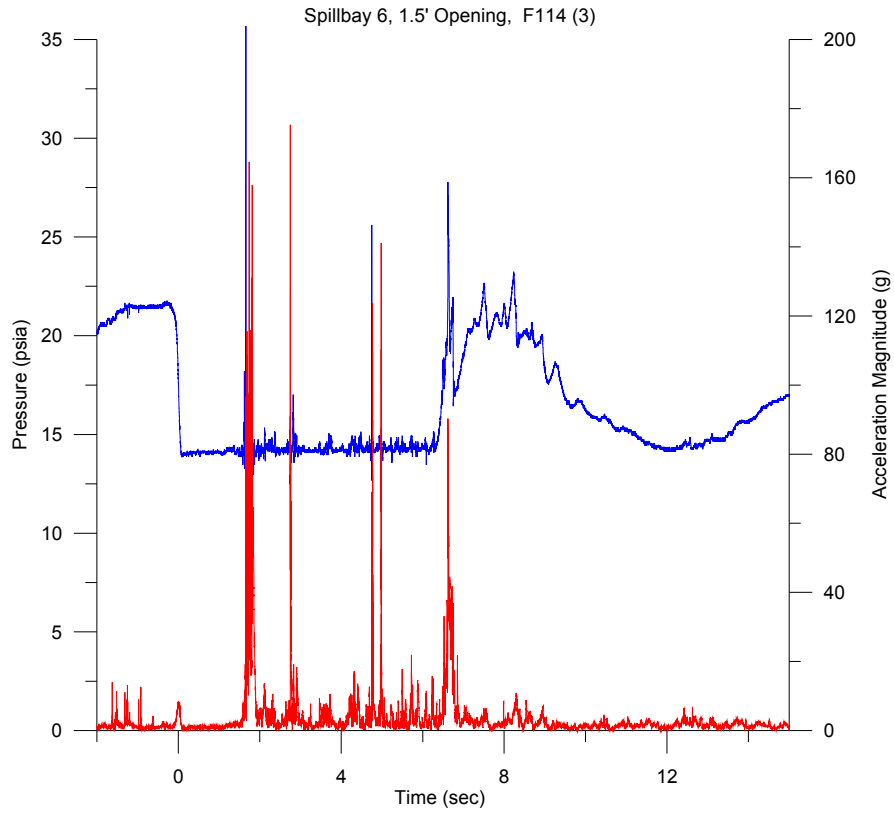


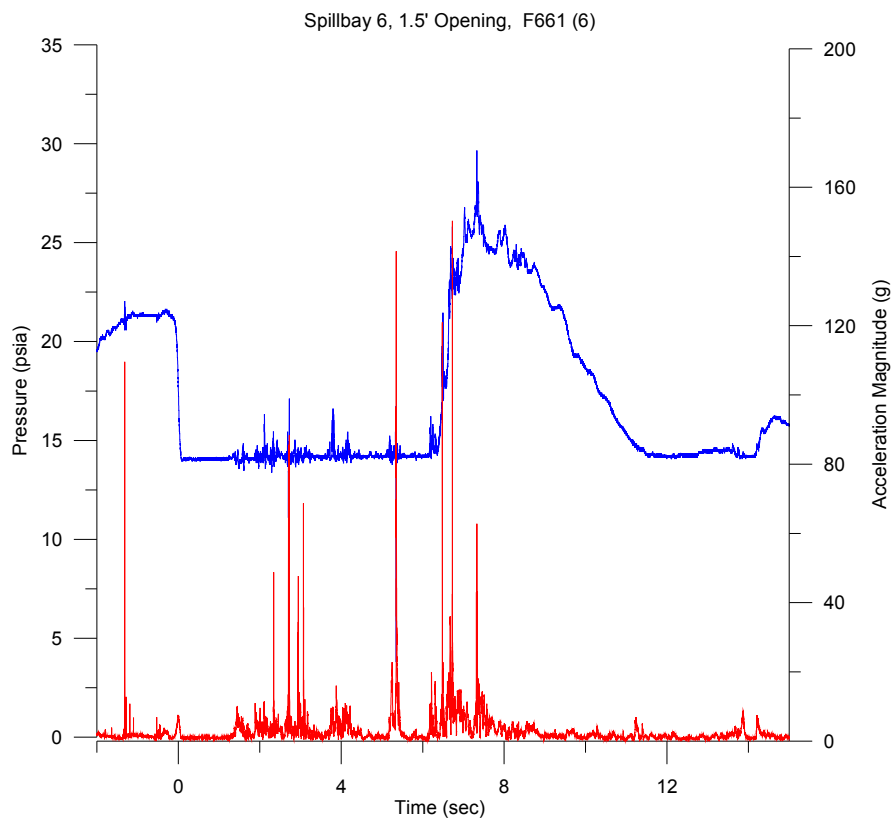
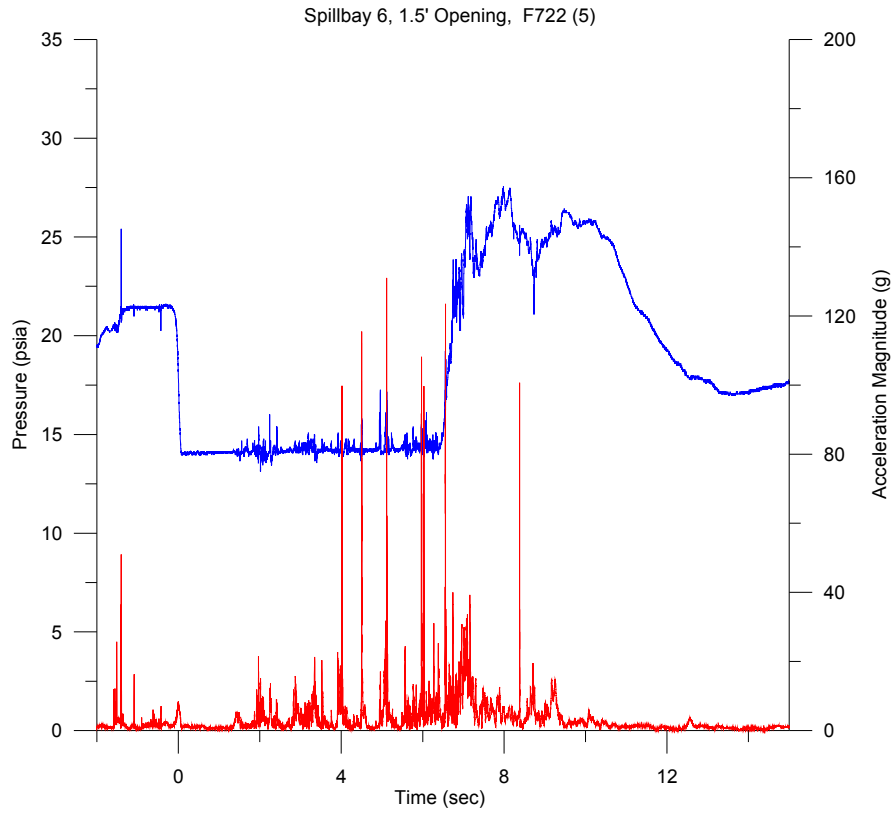


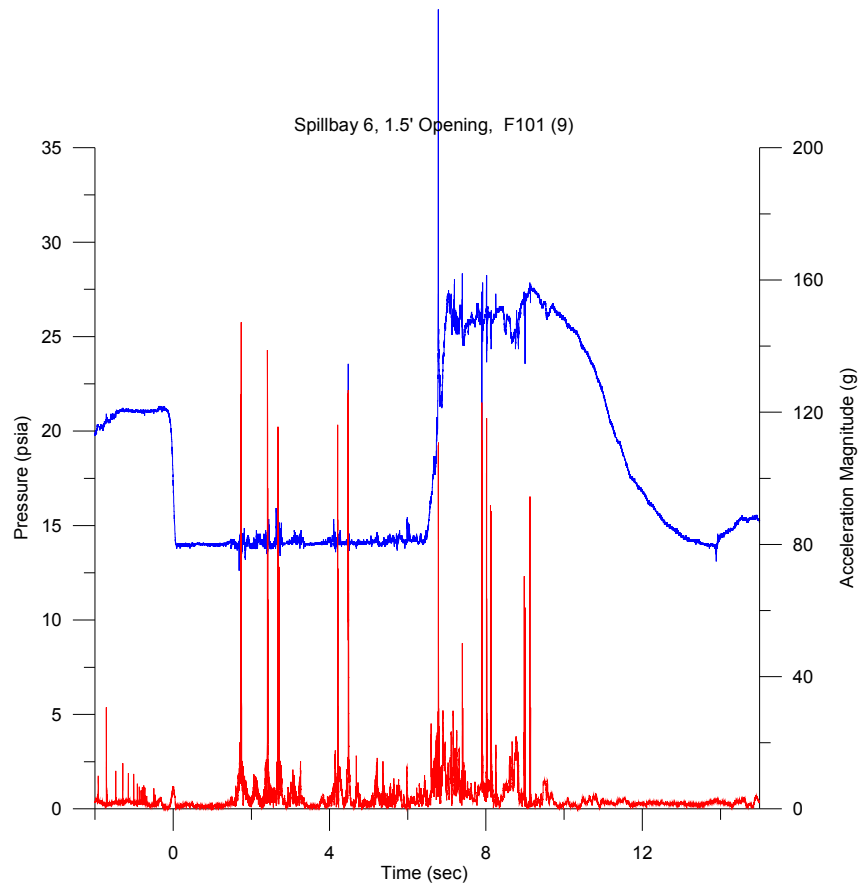
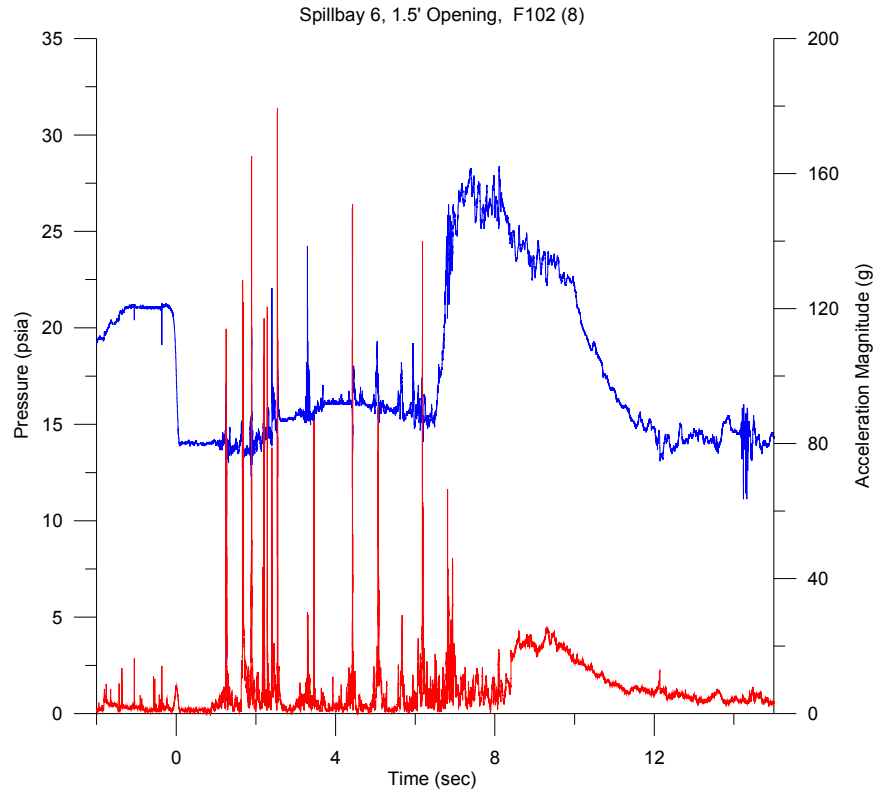
## **Detroit Dam Spillway Evaluation**

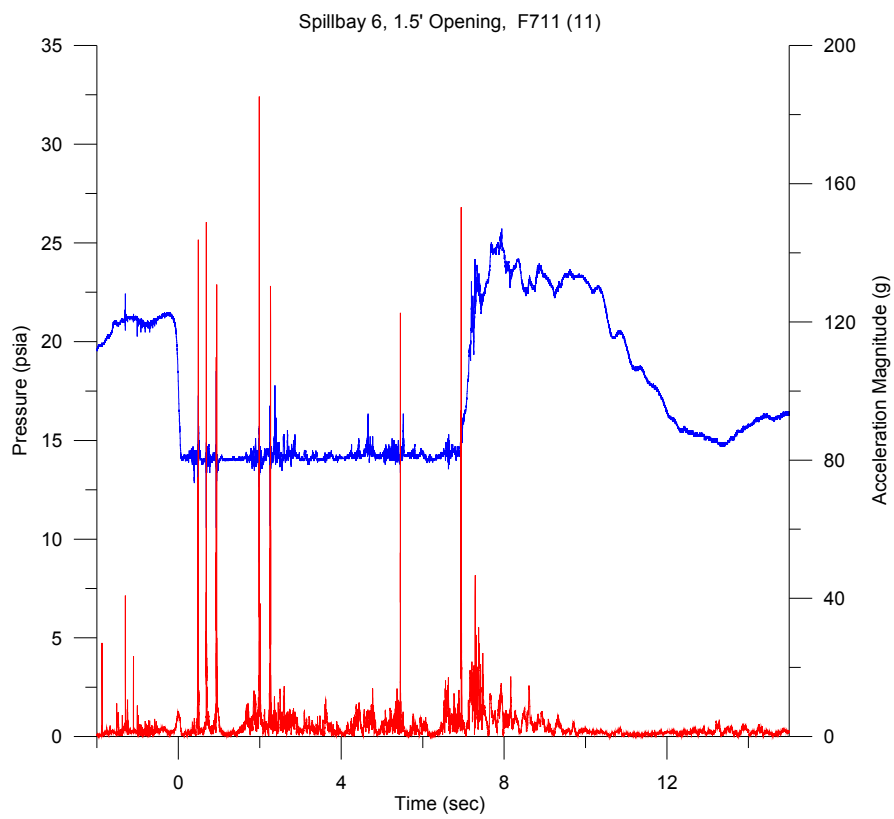
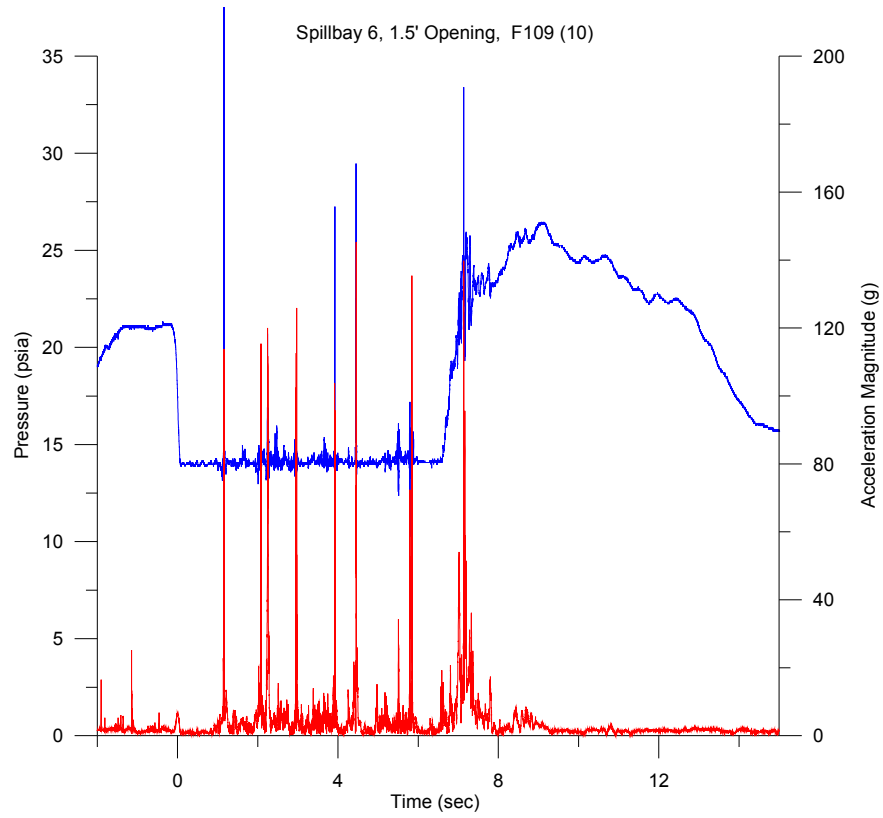
### **Spillbay 6, 1.5-ft Gate Opening**



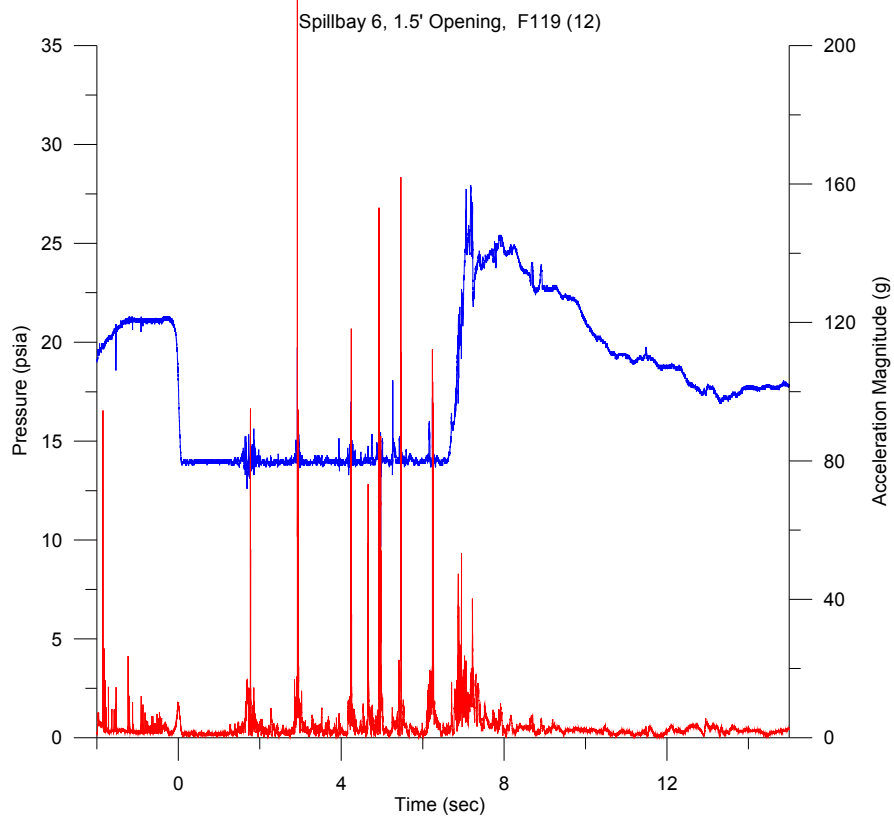
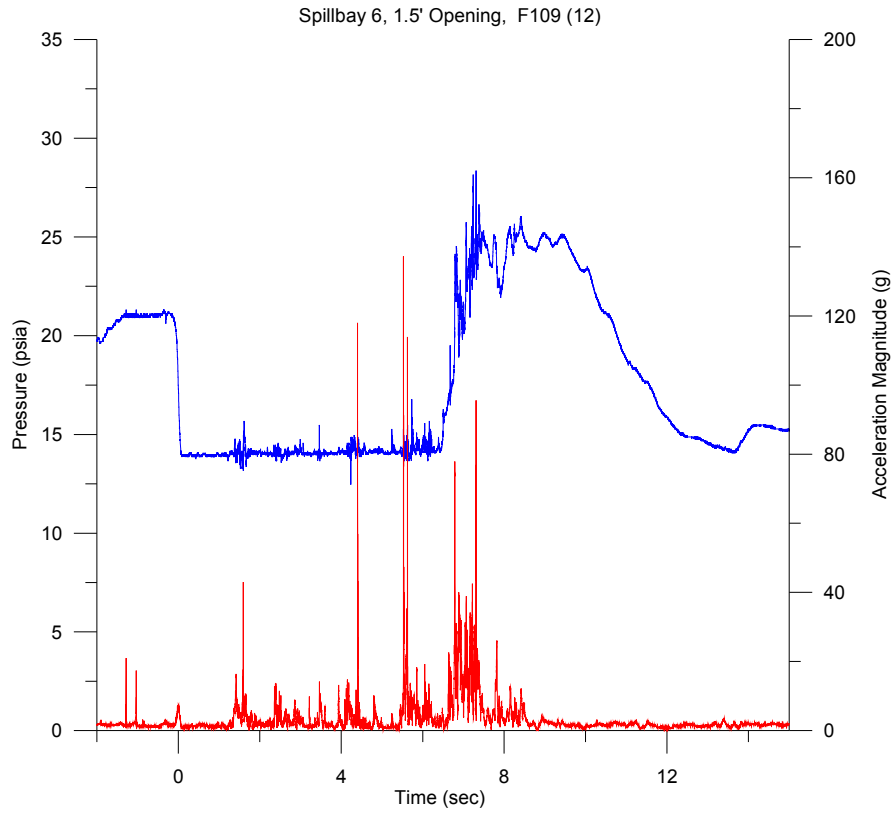


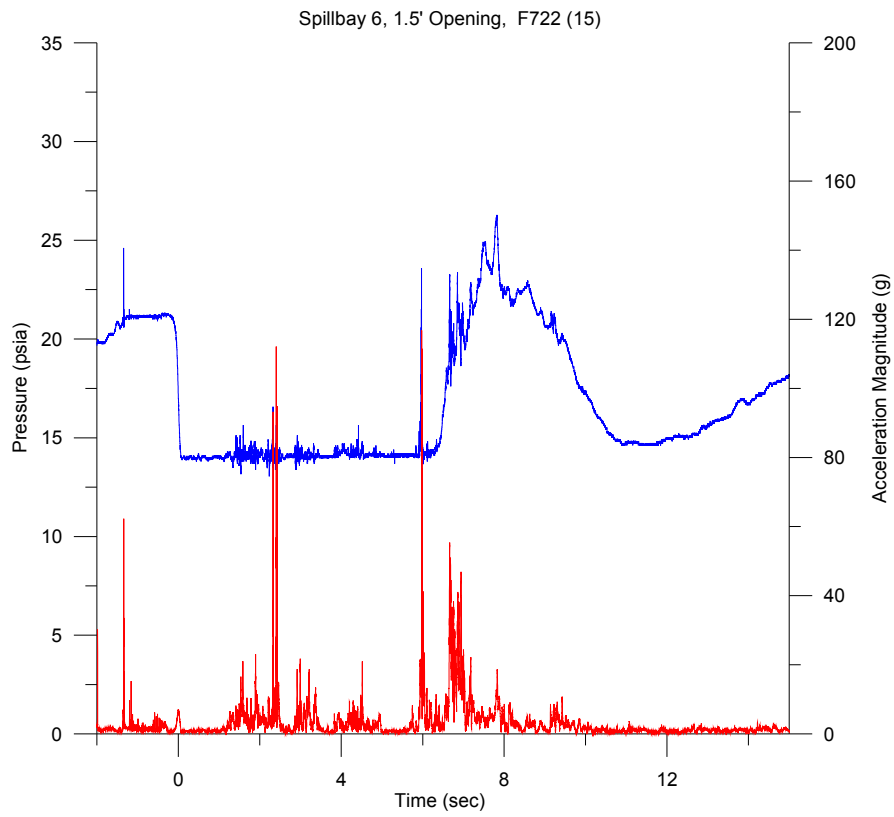
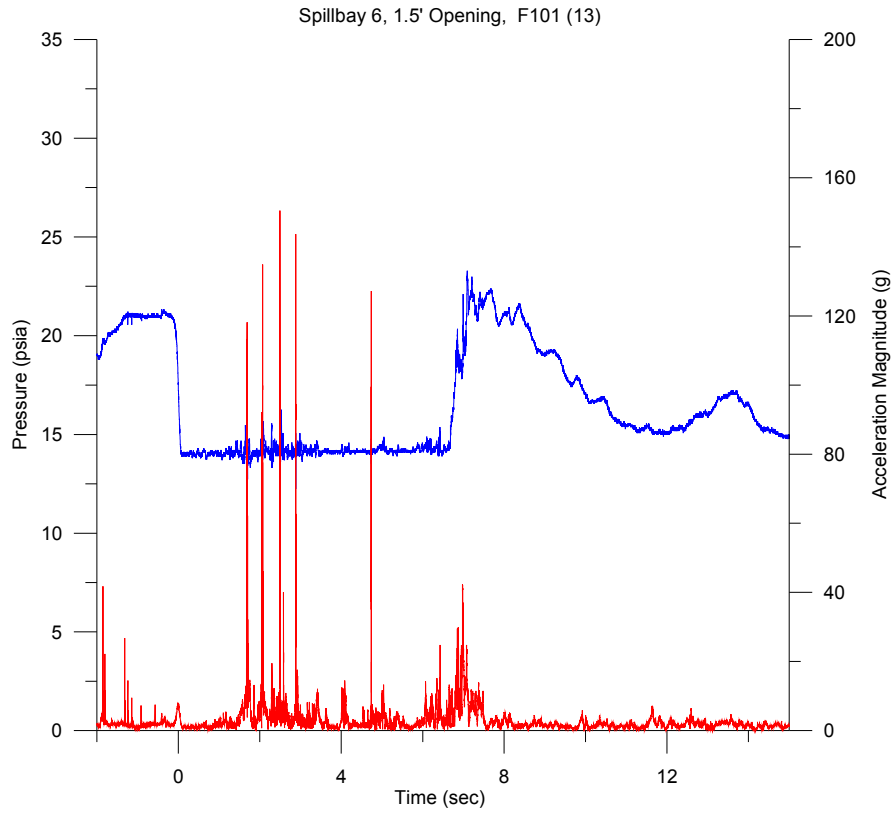


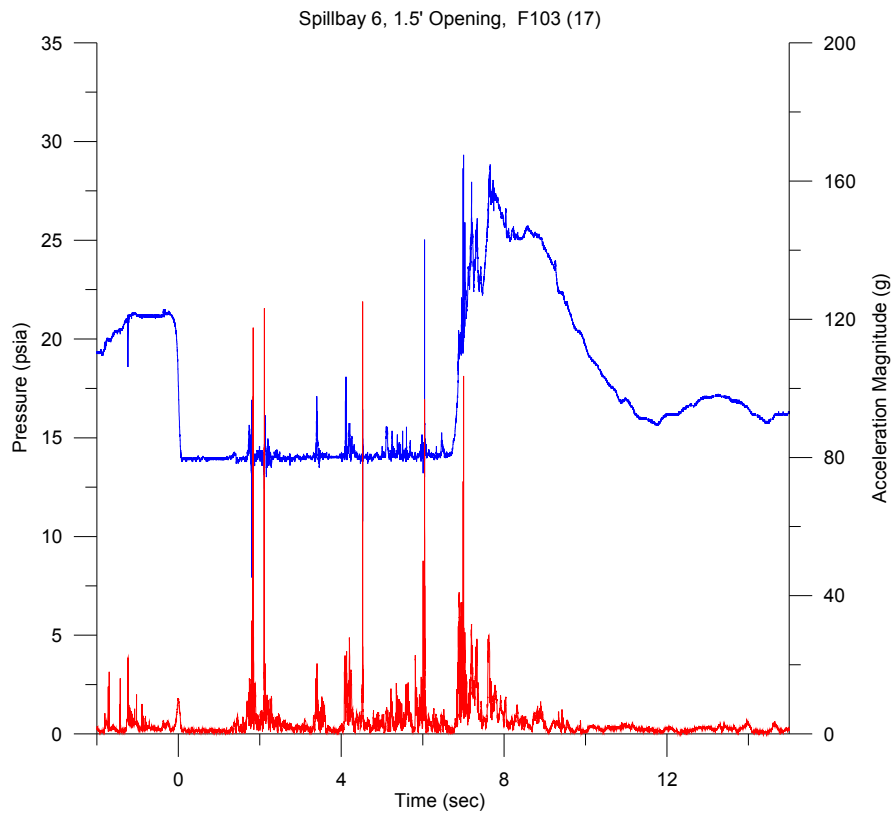
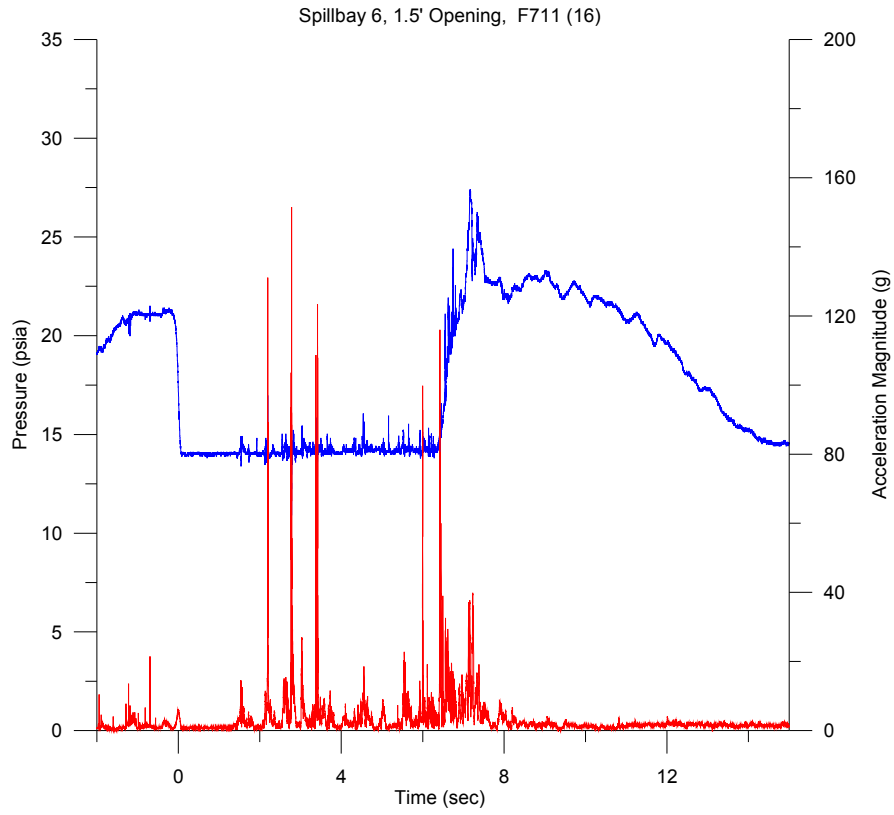






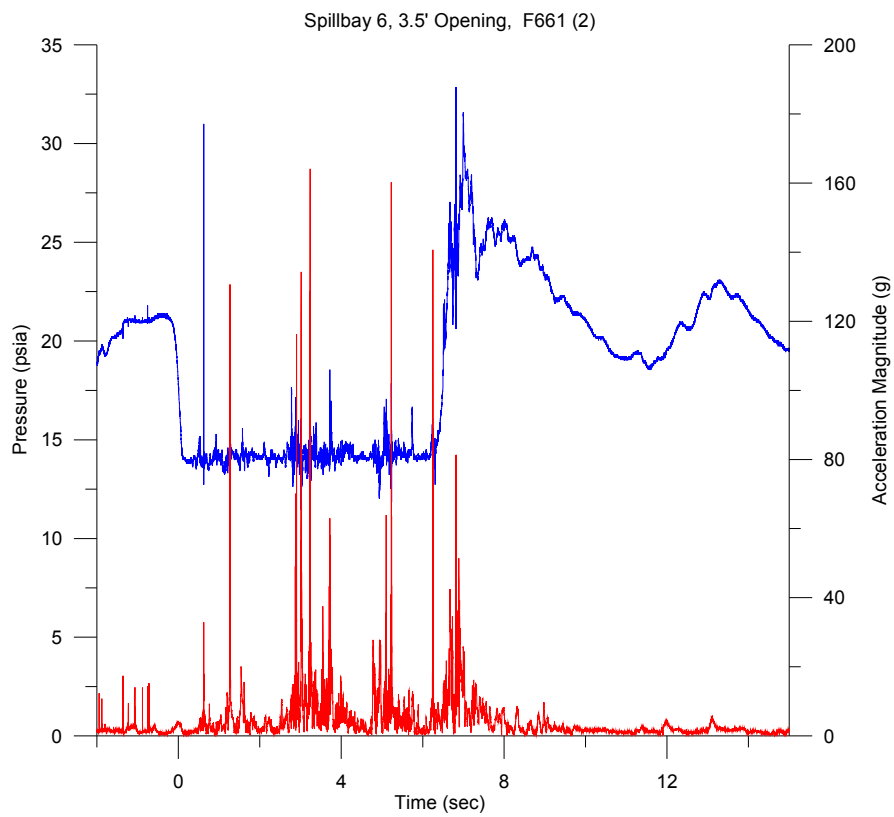
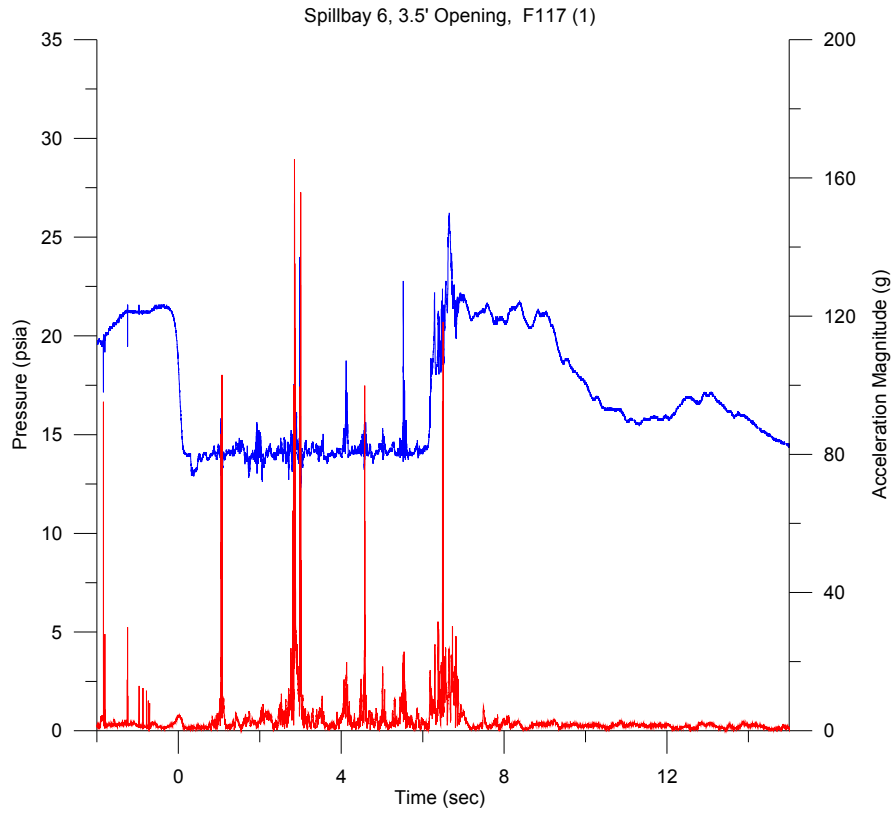


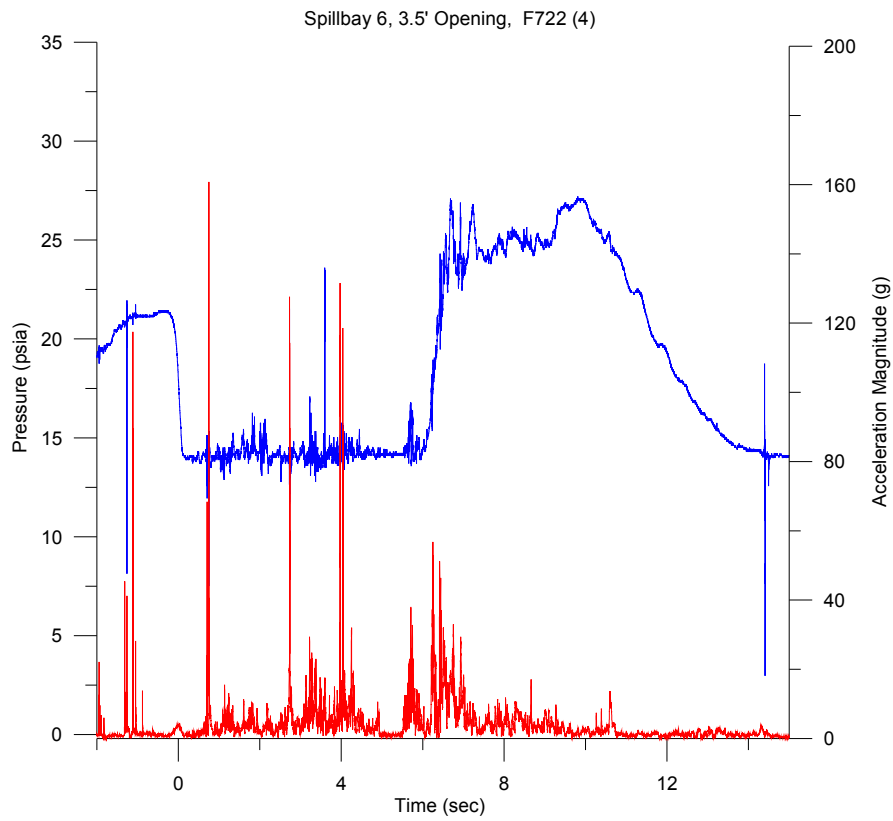
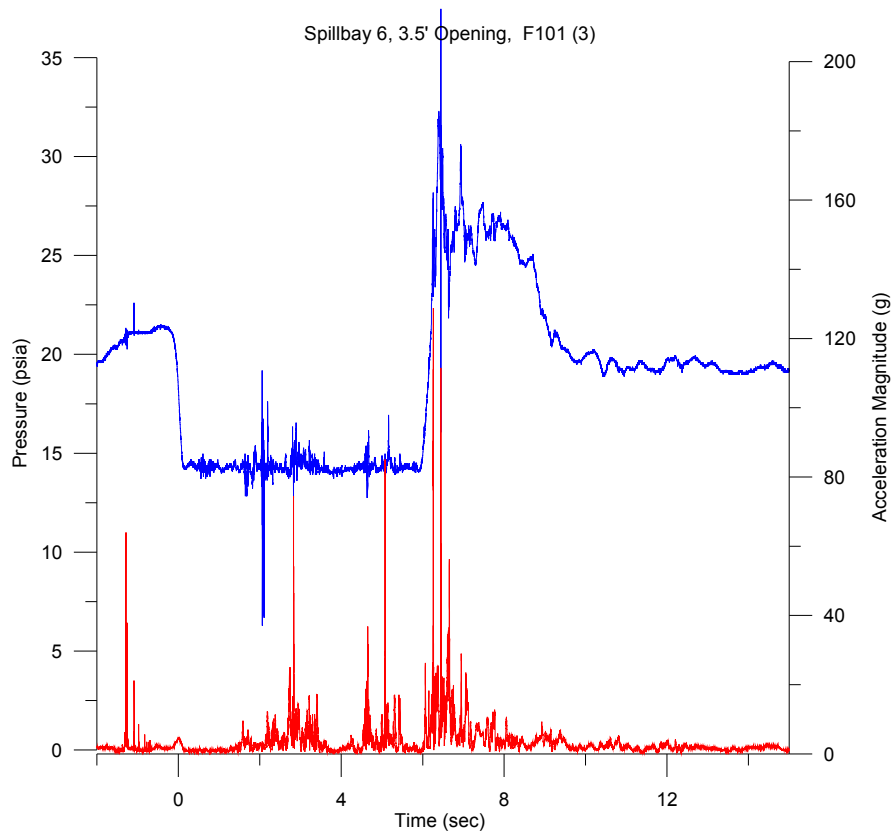


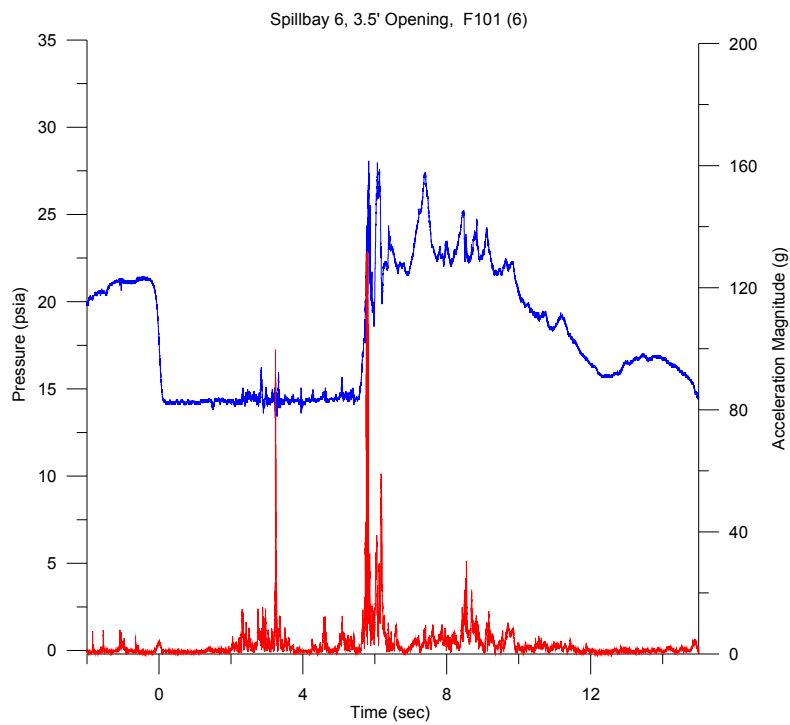
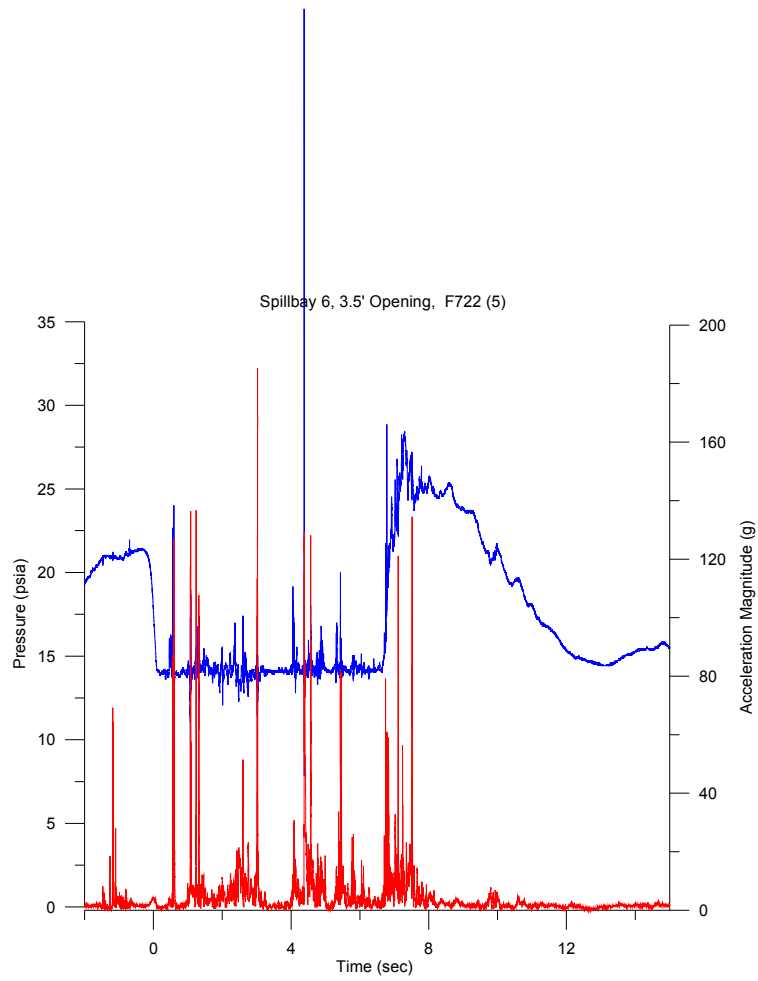


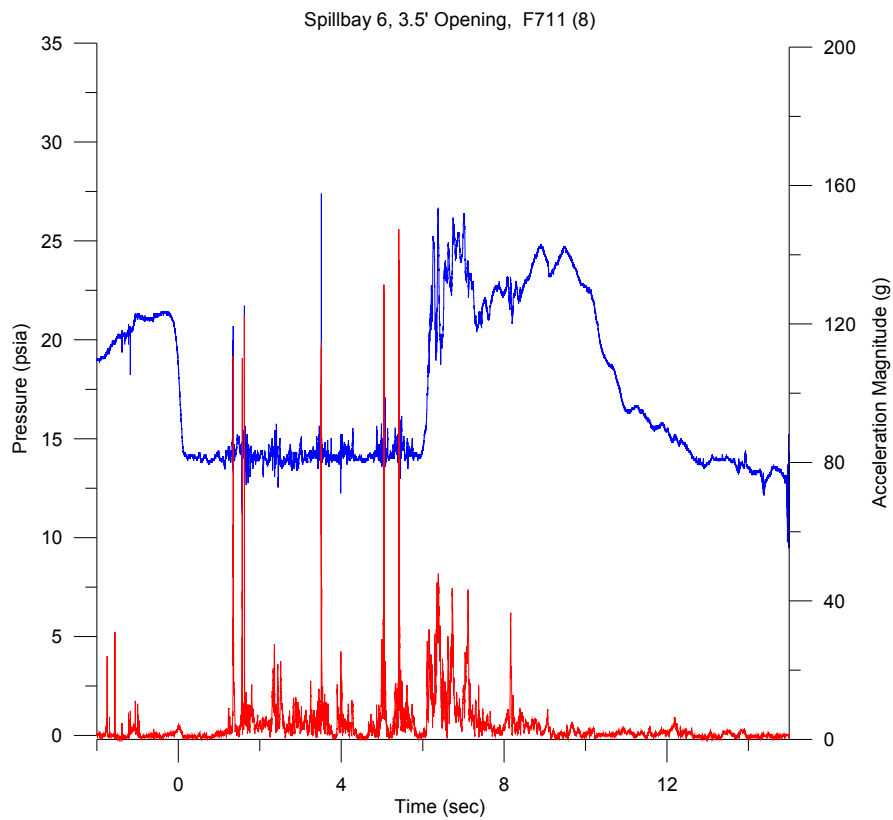
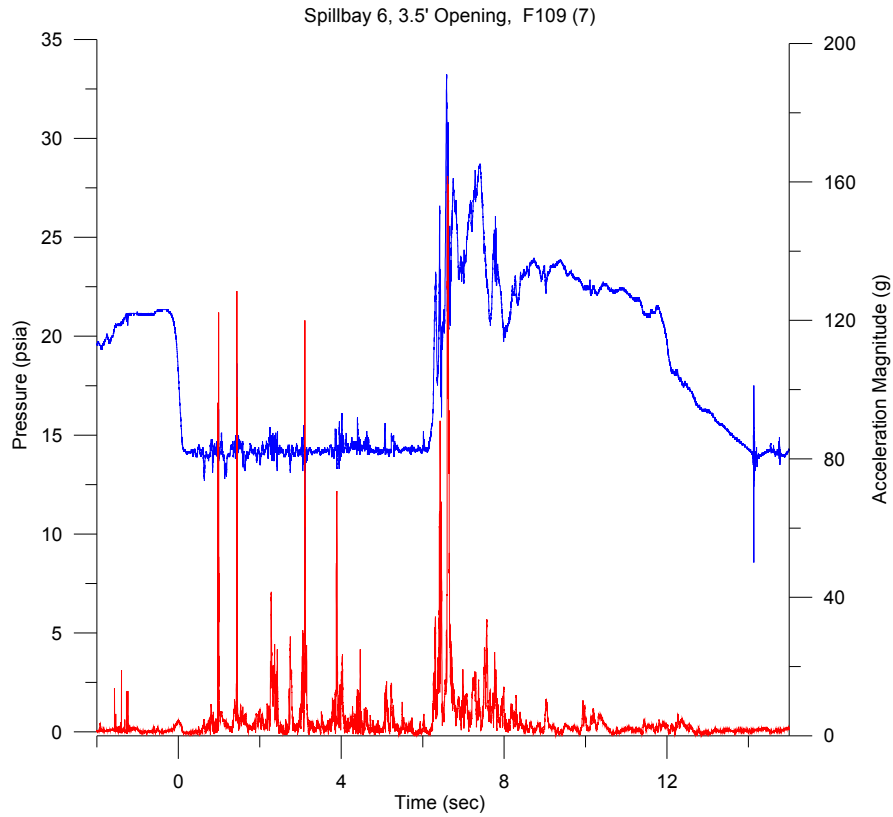
## **Detroit Dam Spillway Evaluation**

### **Spillbay 6, 3.5-ft Gate Opening**

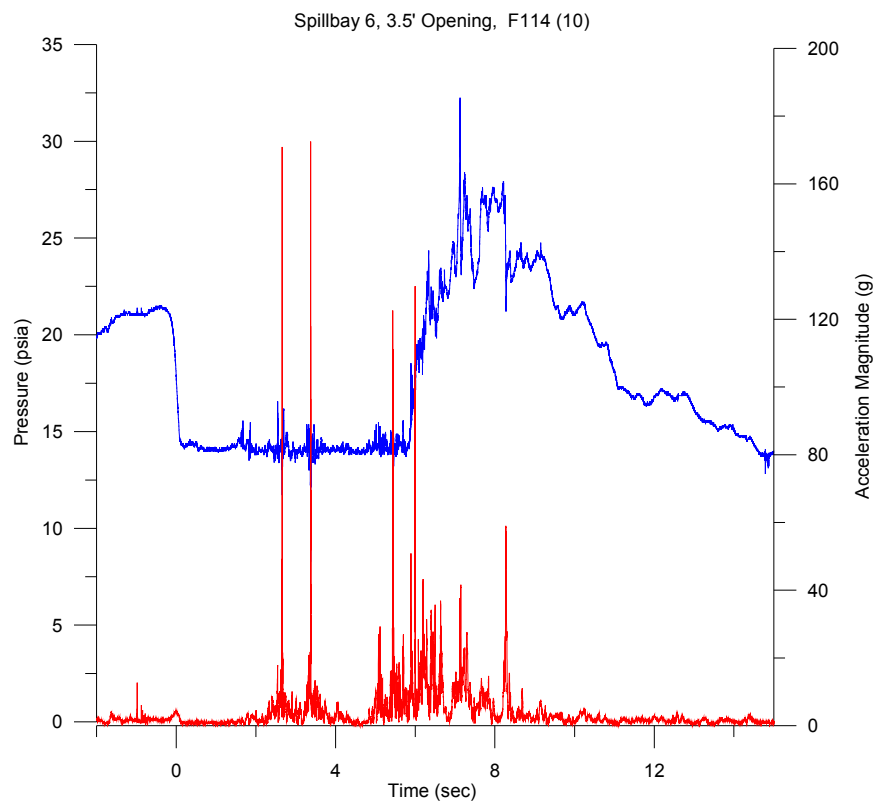
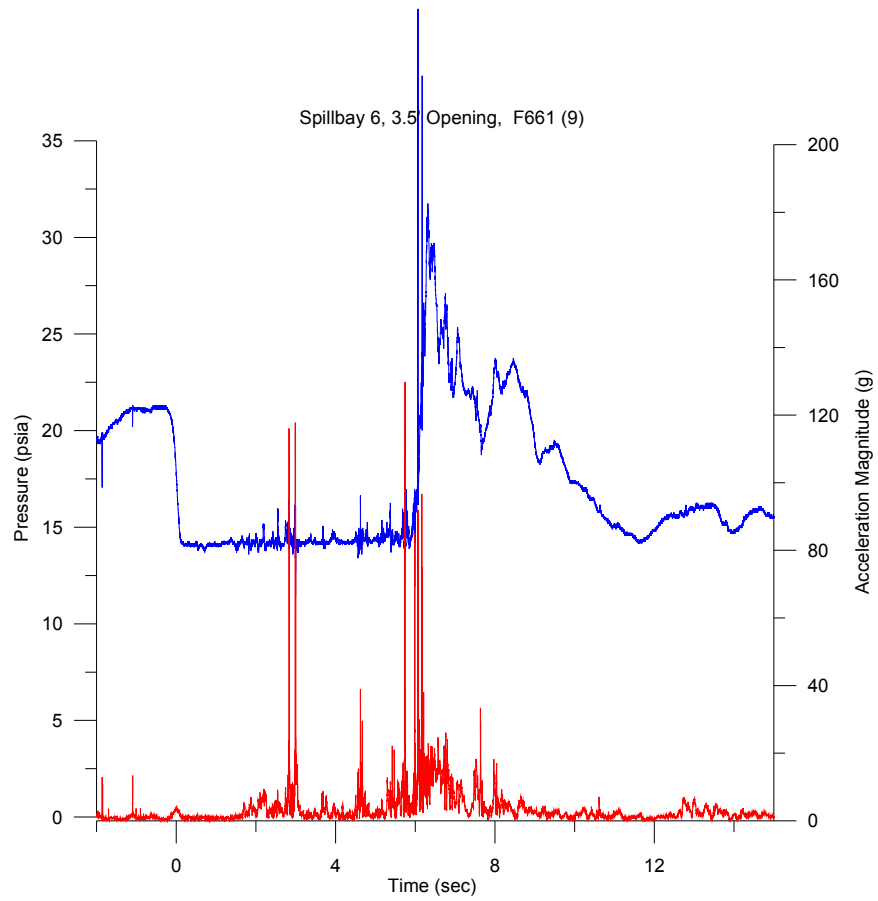


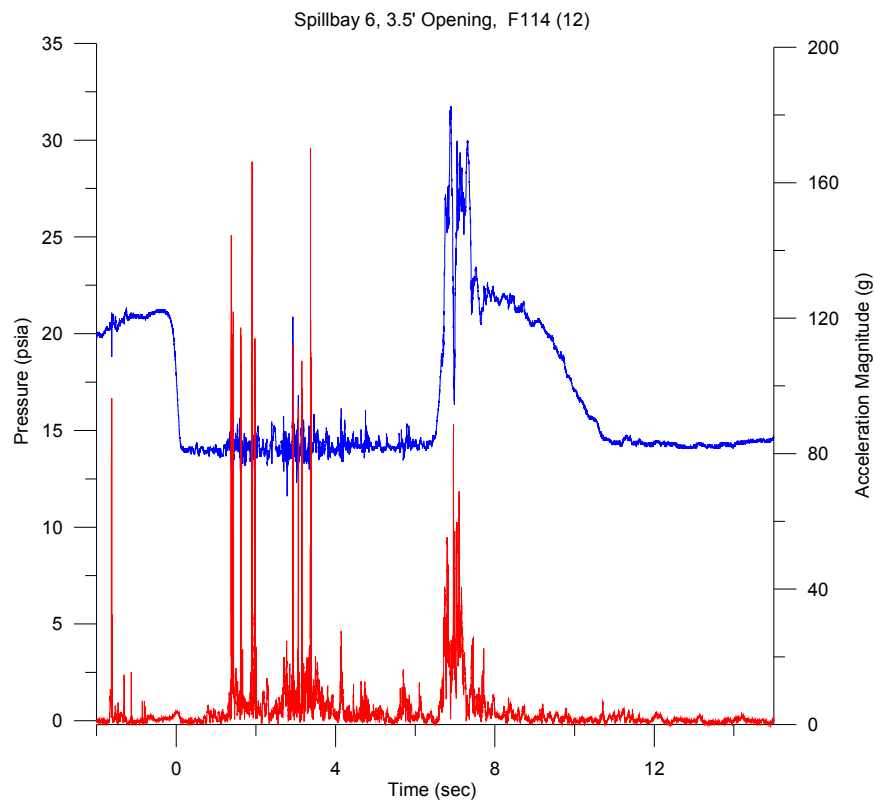
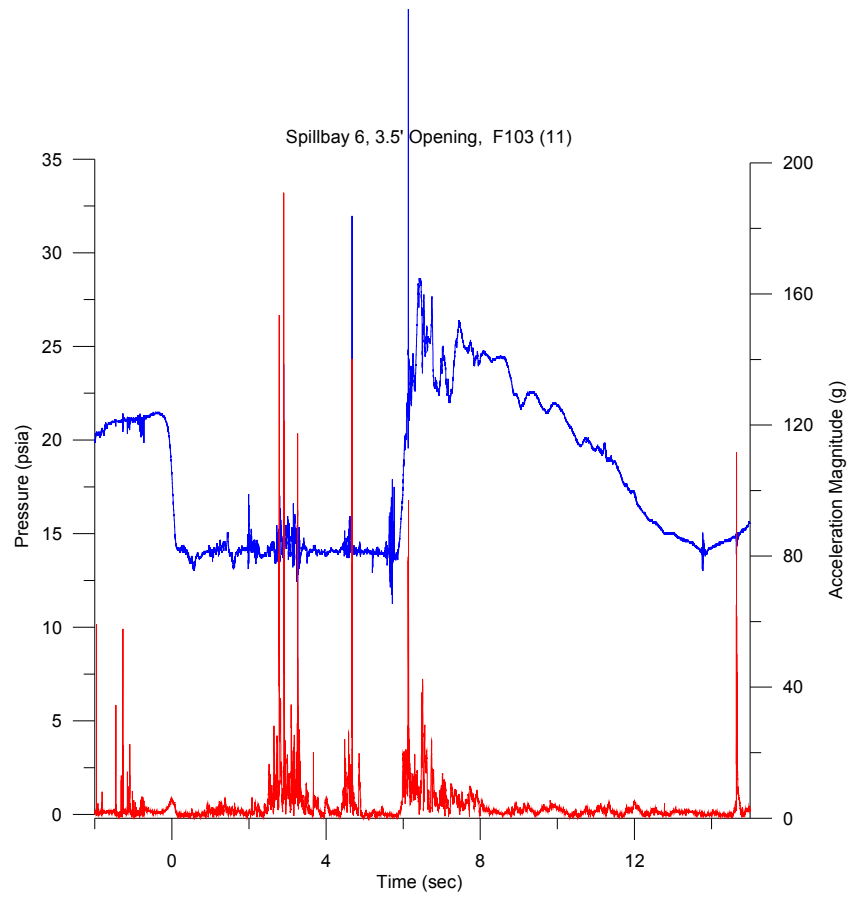


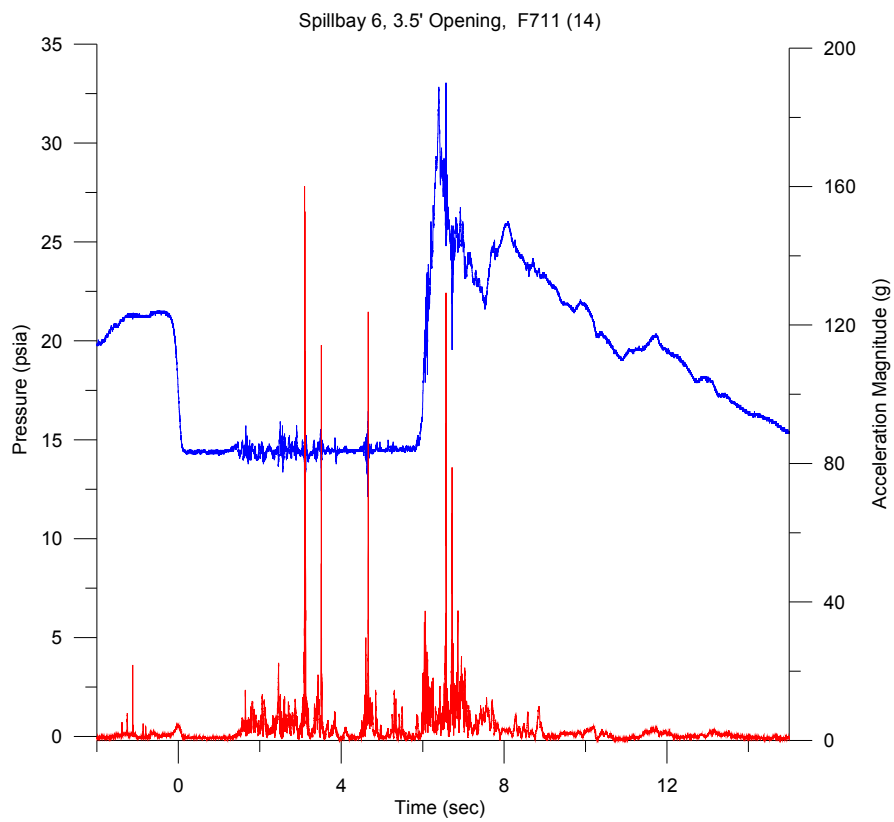
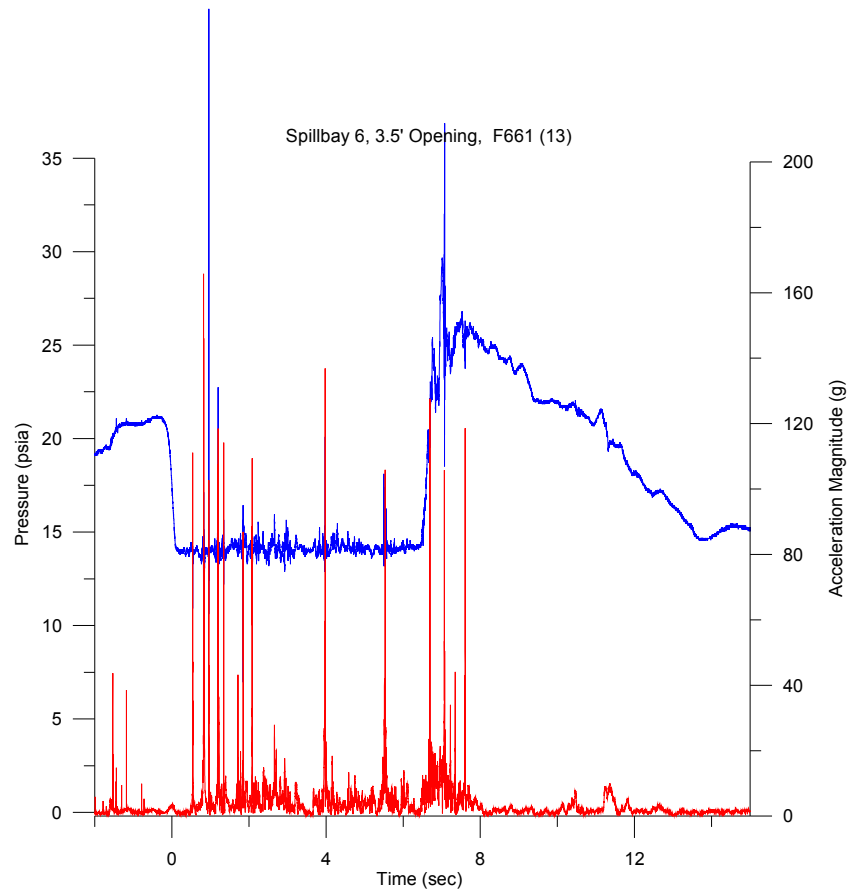


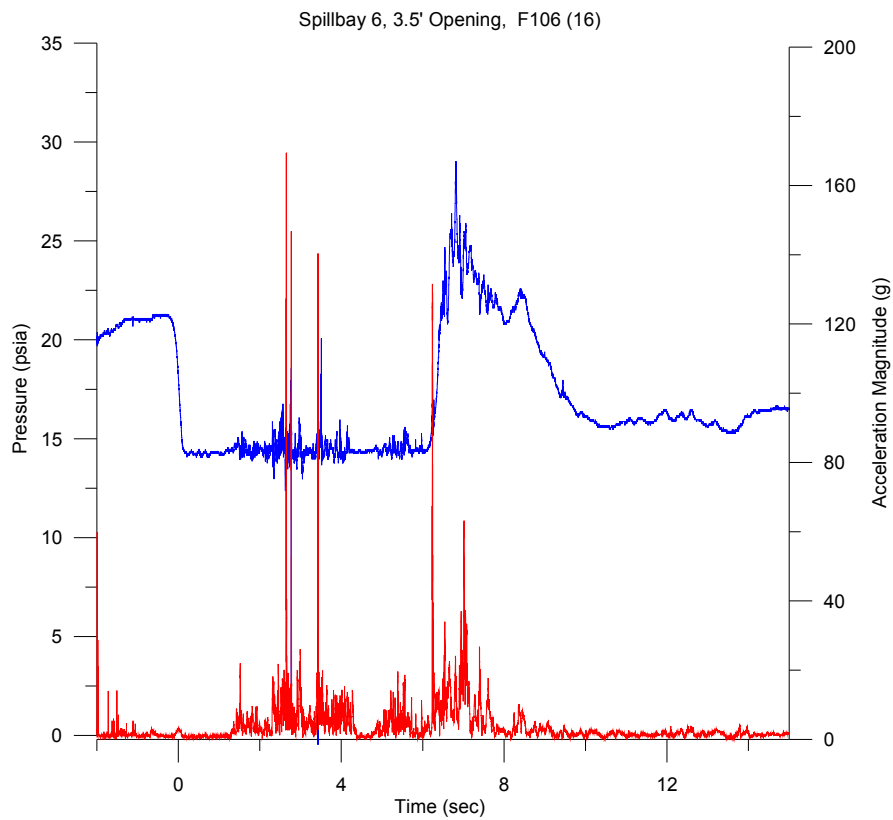
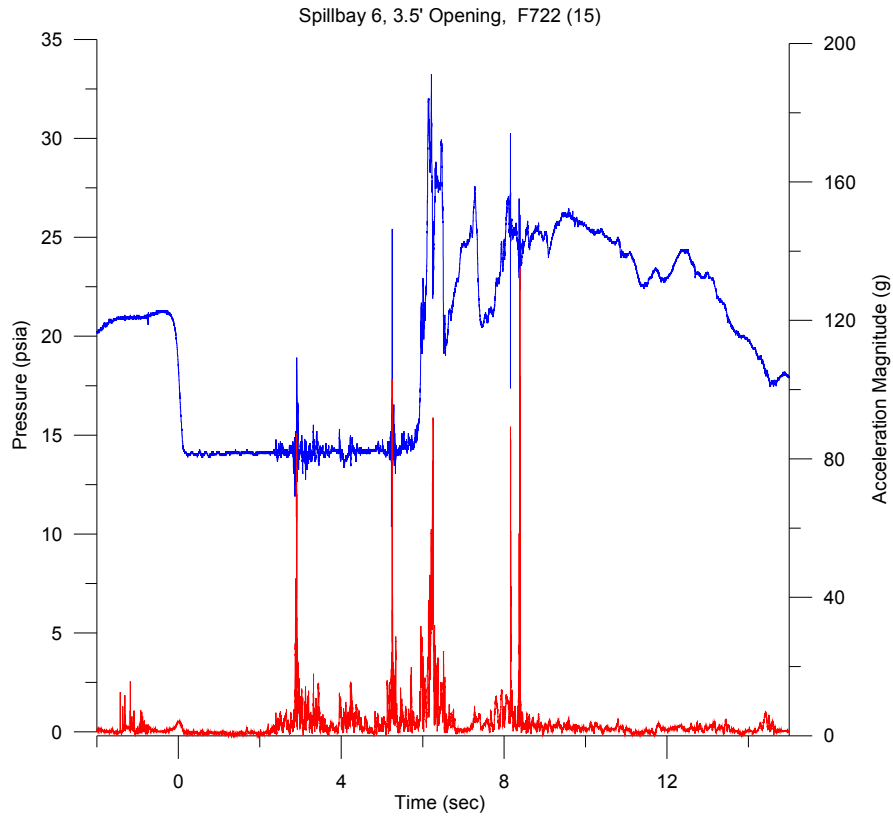


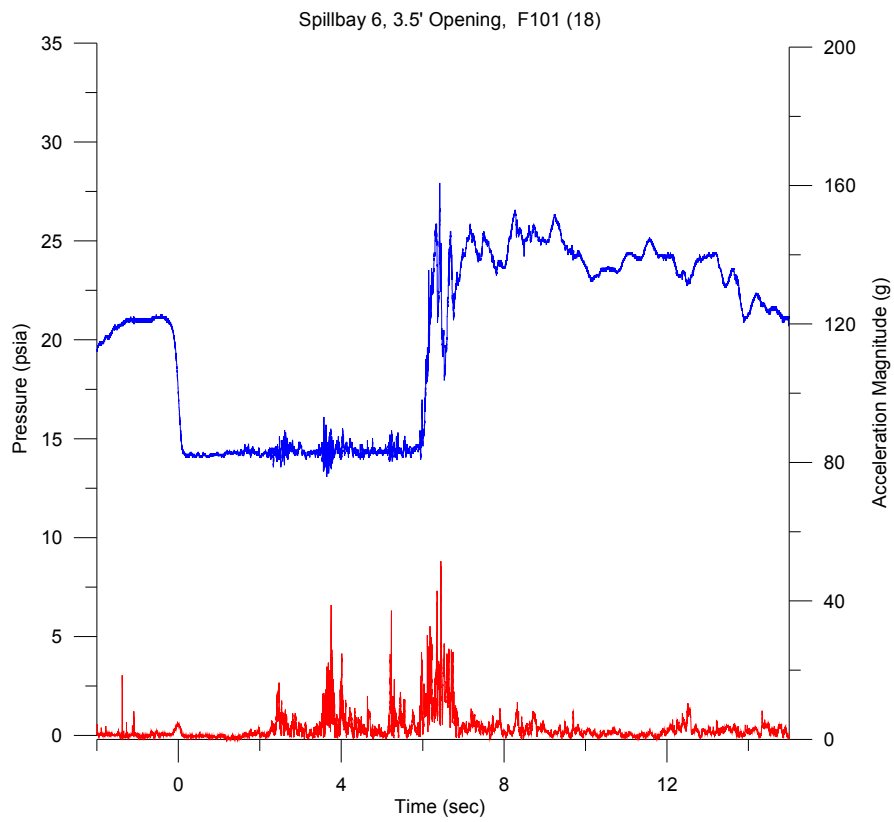
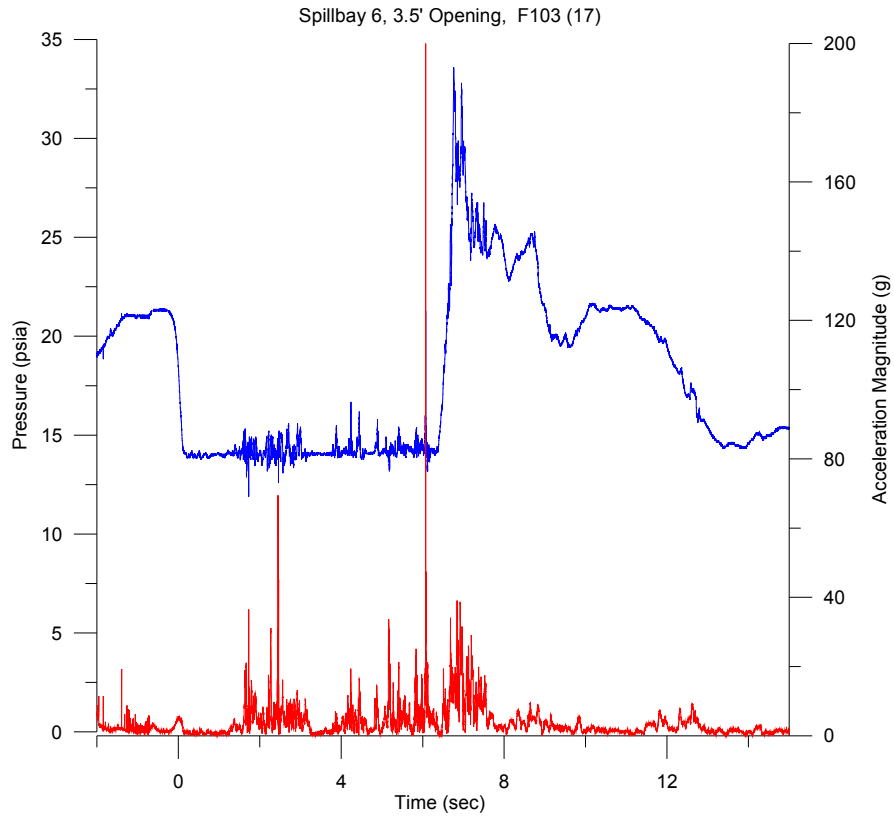


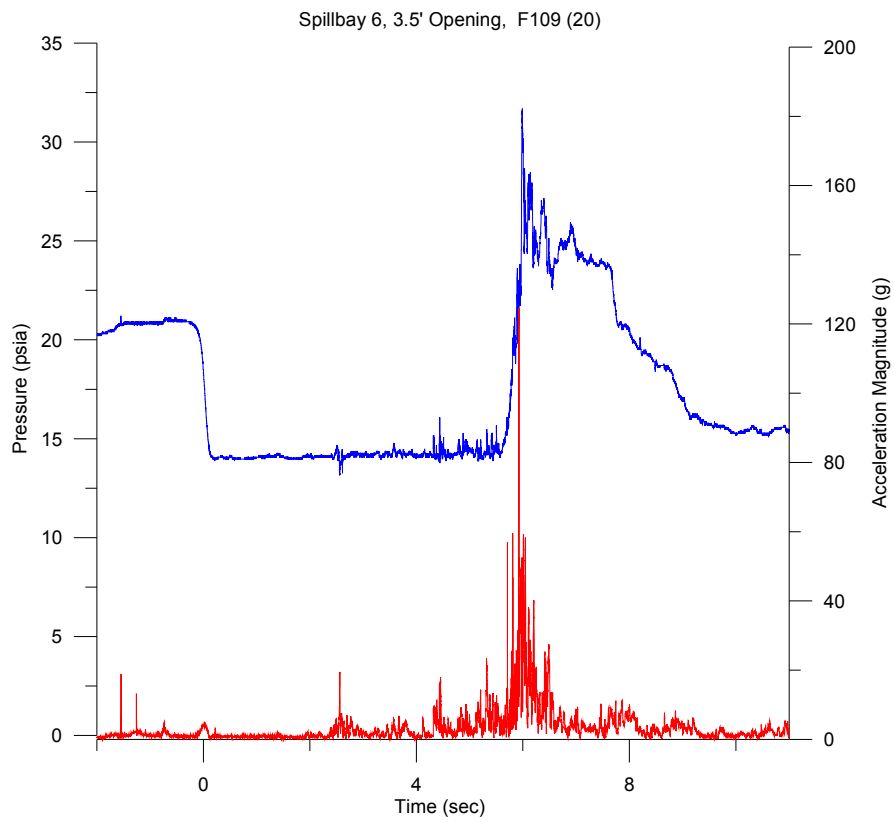
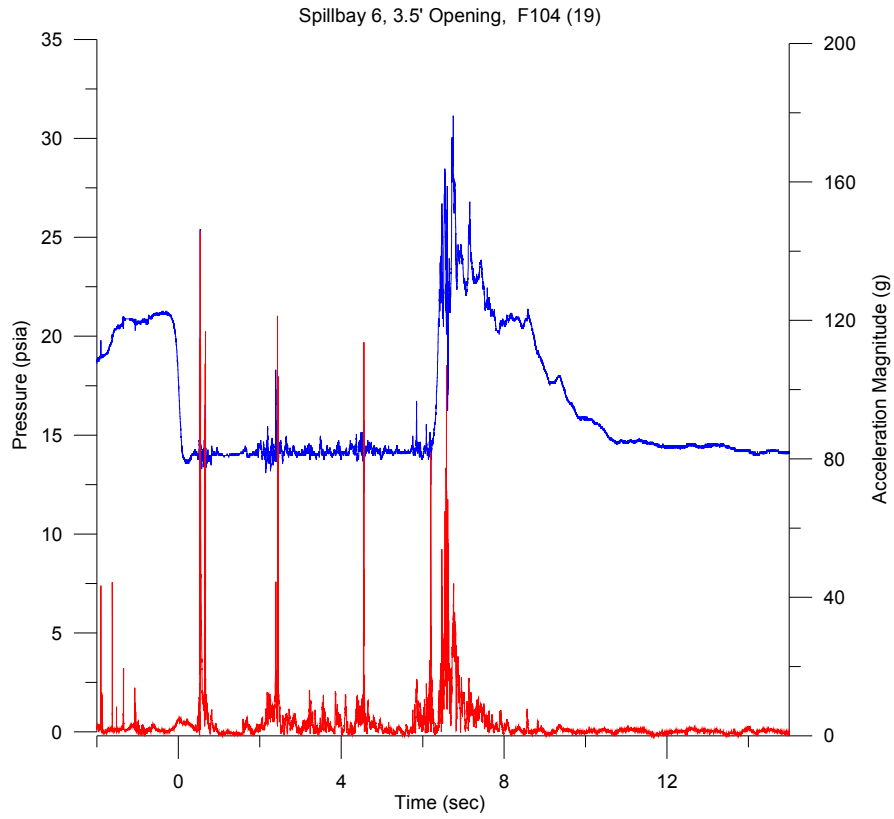


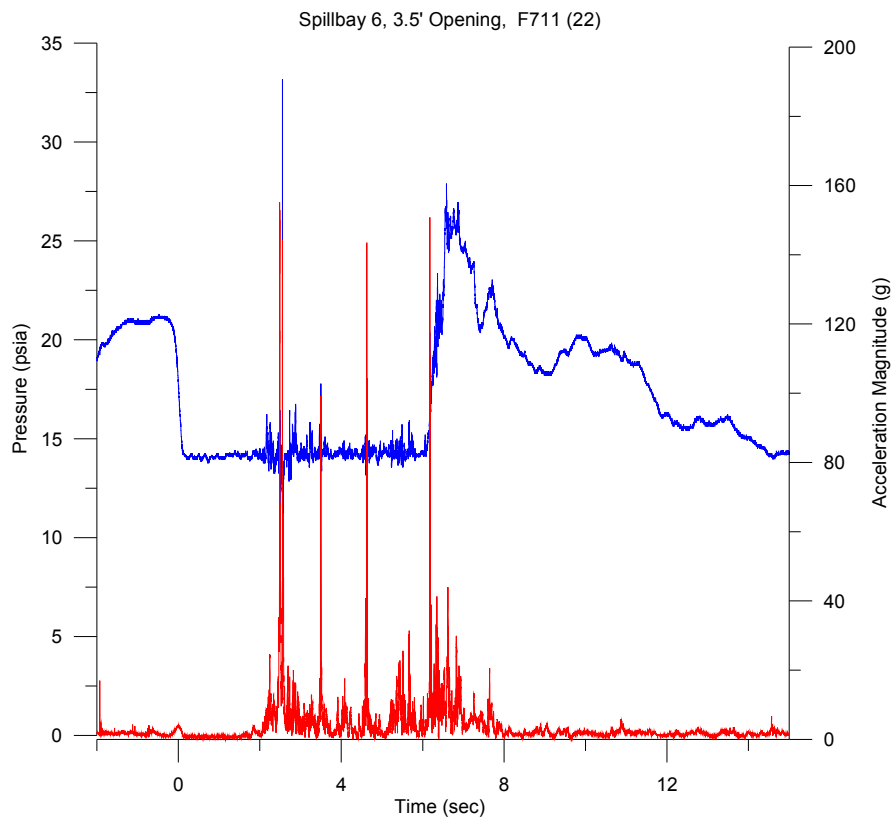
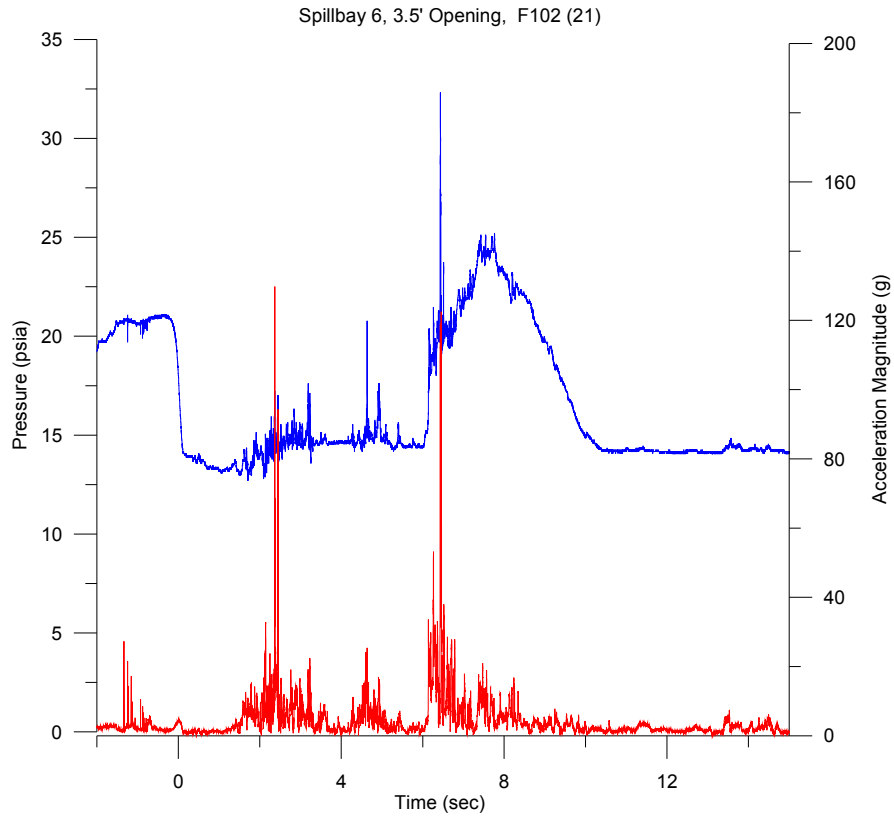


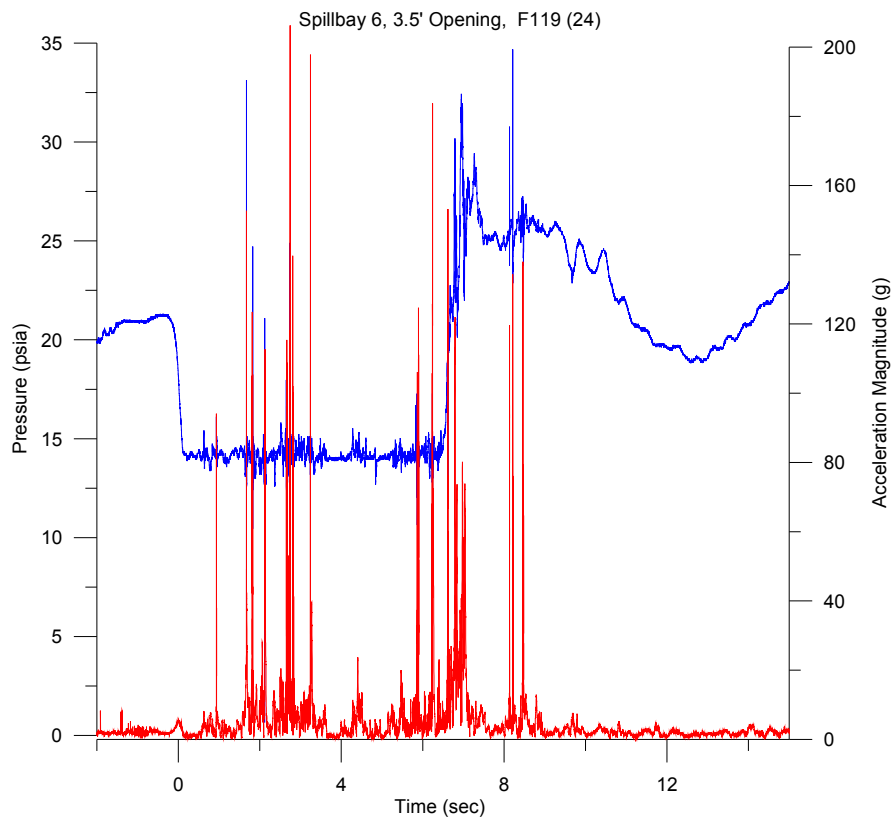
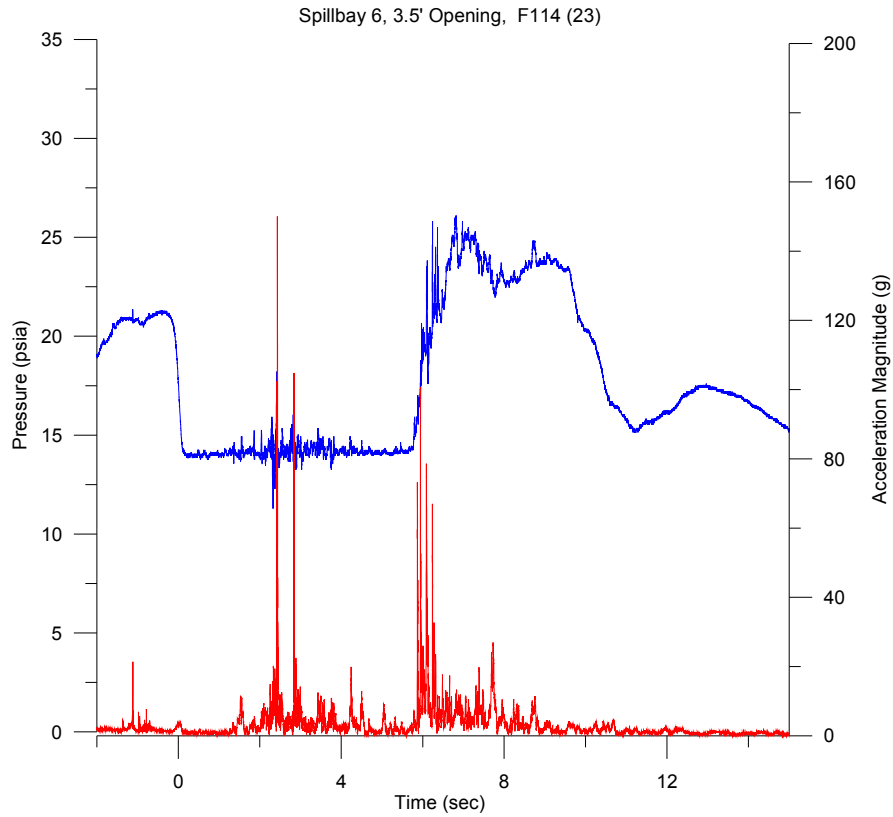




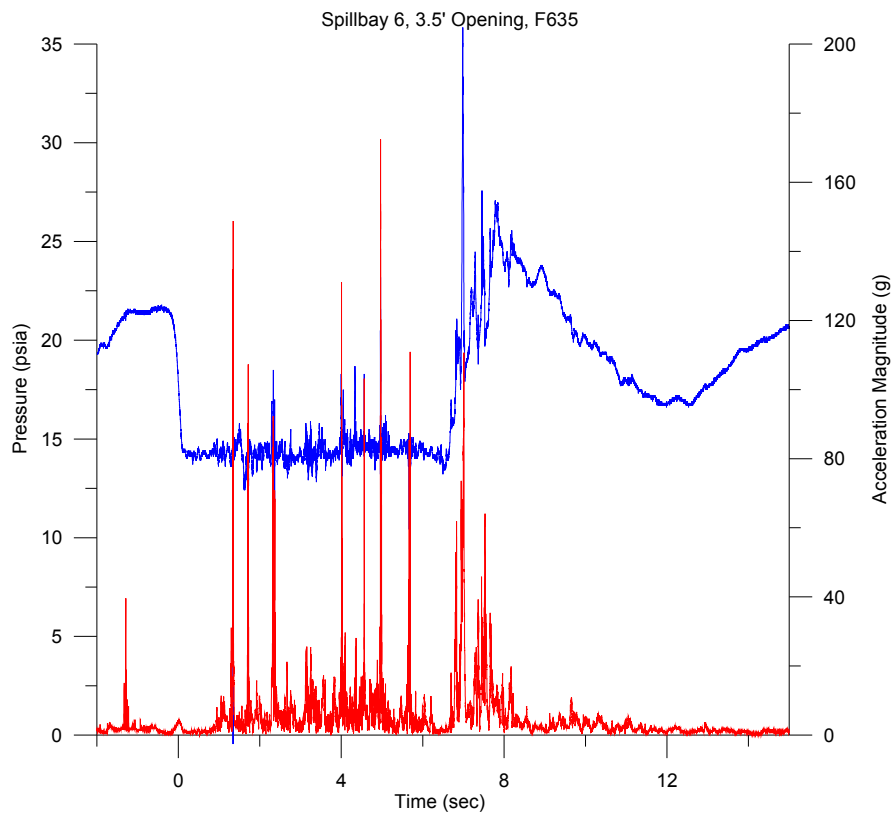
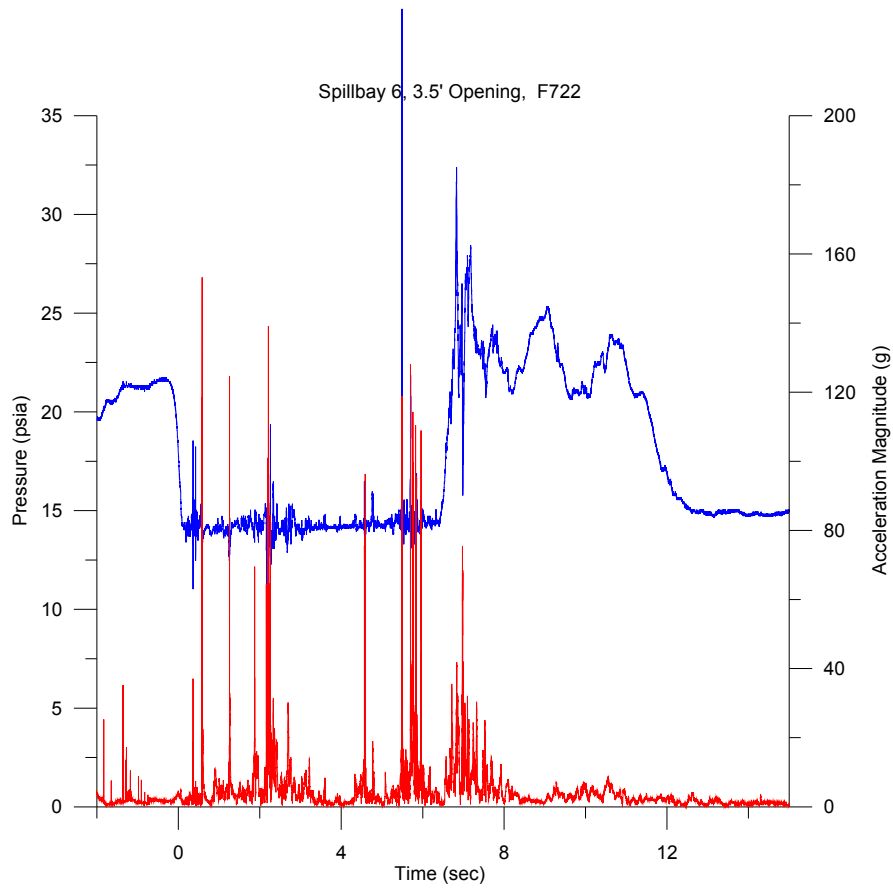






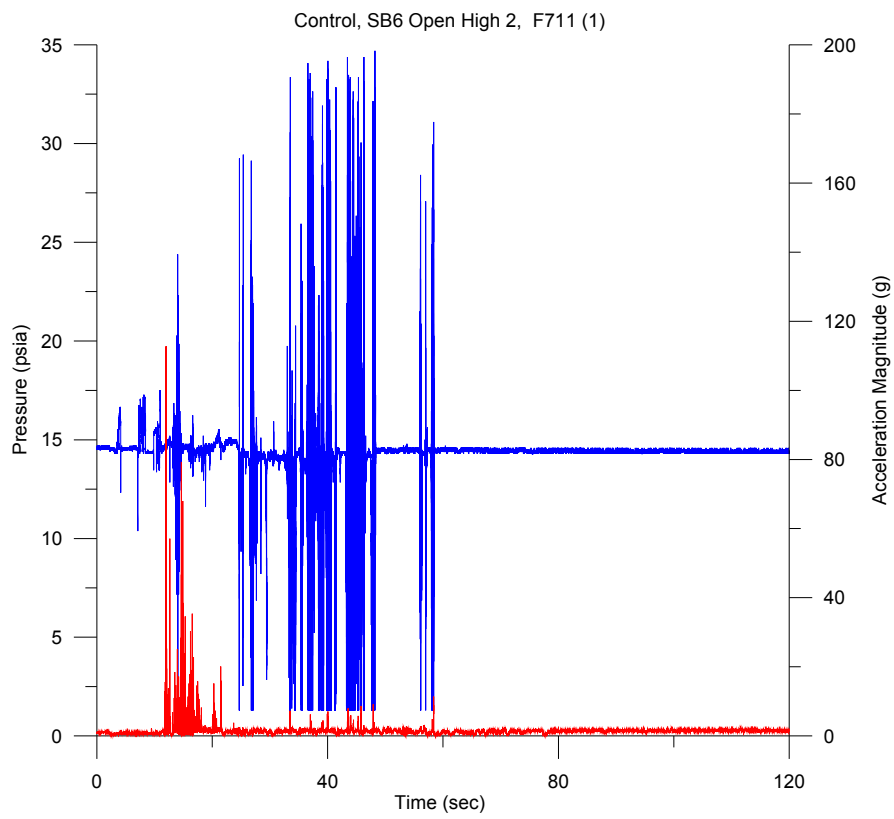
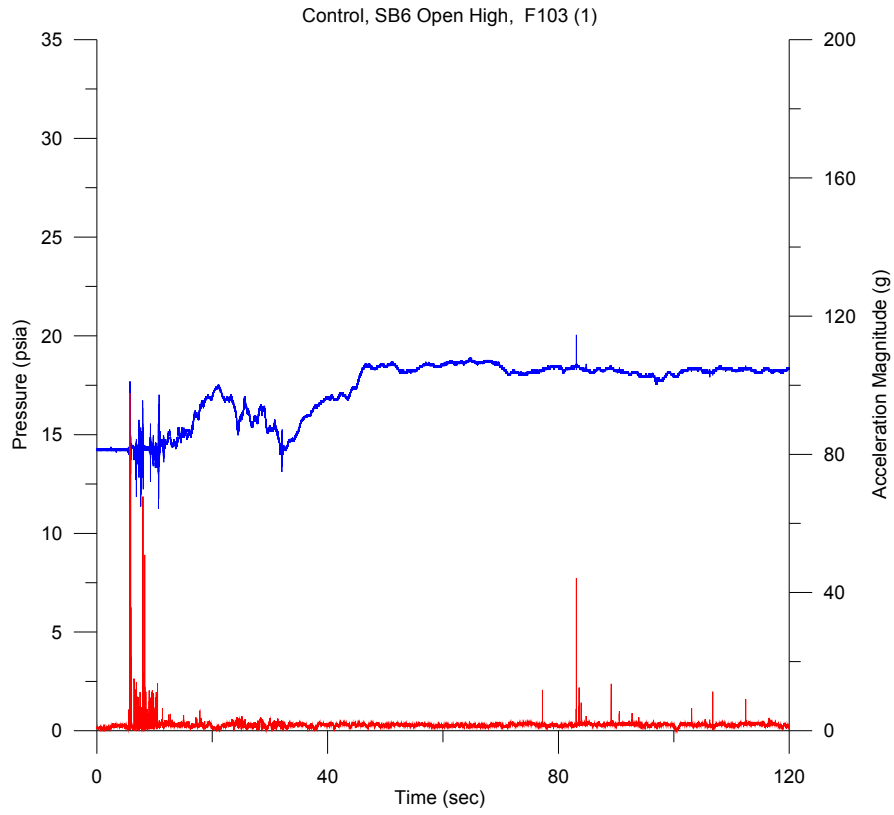


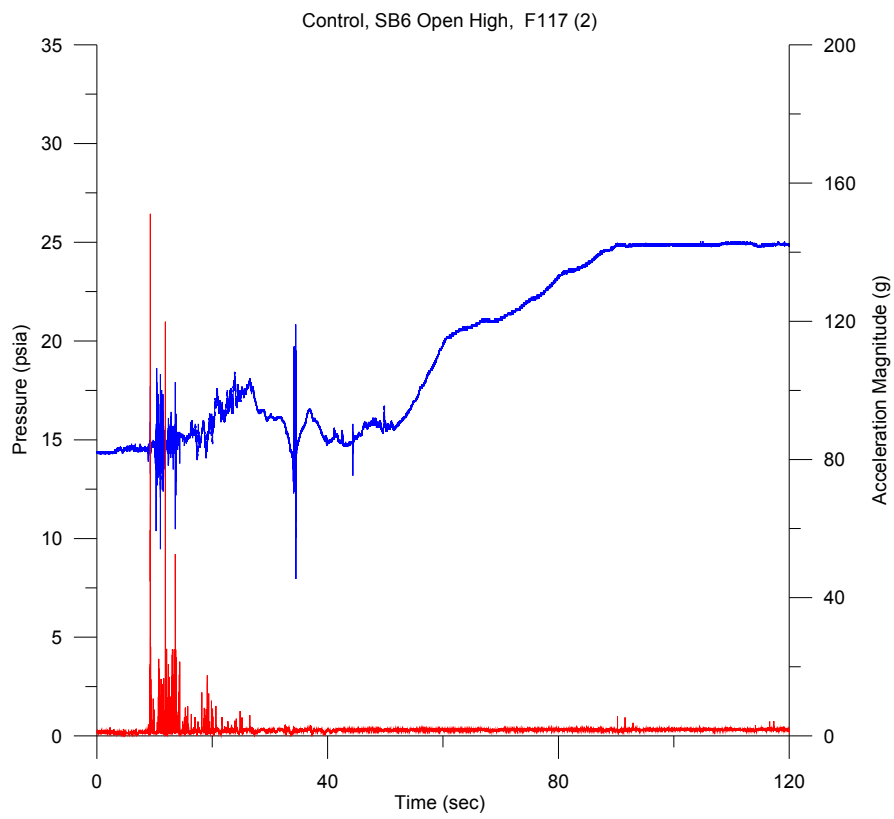
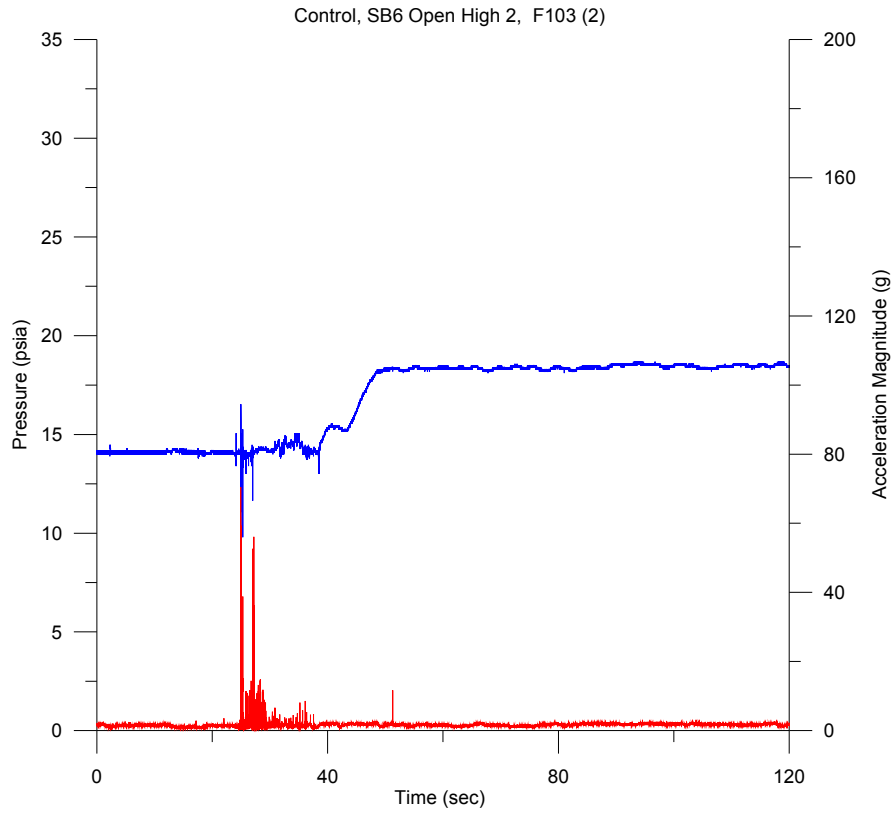


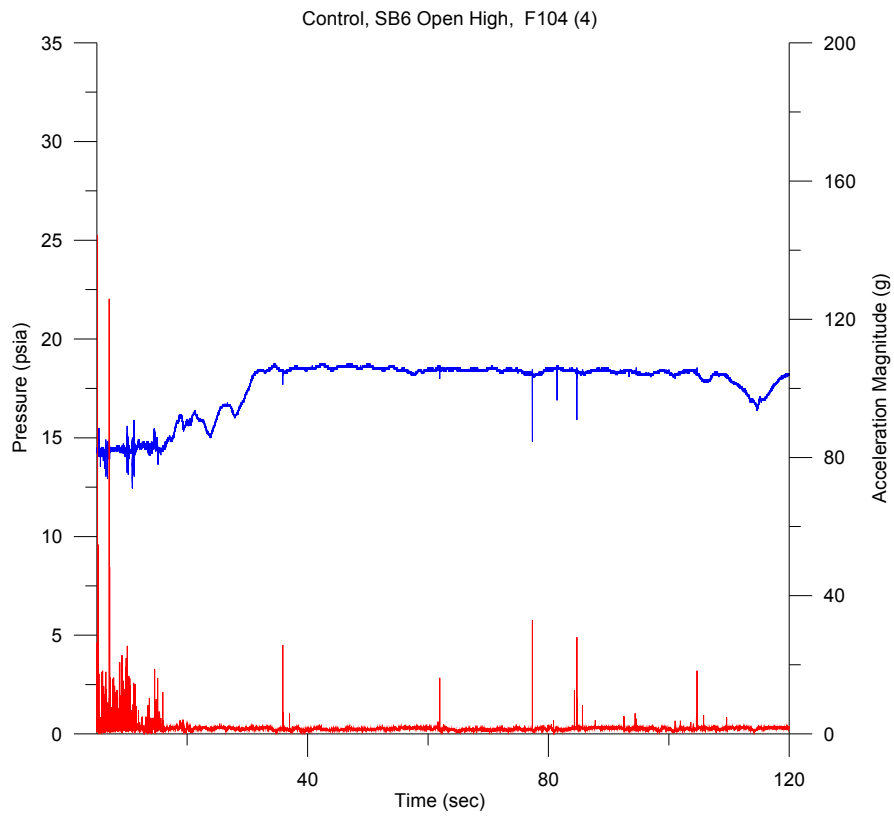
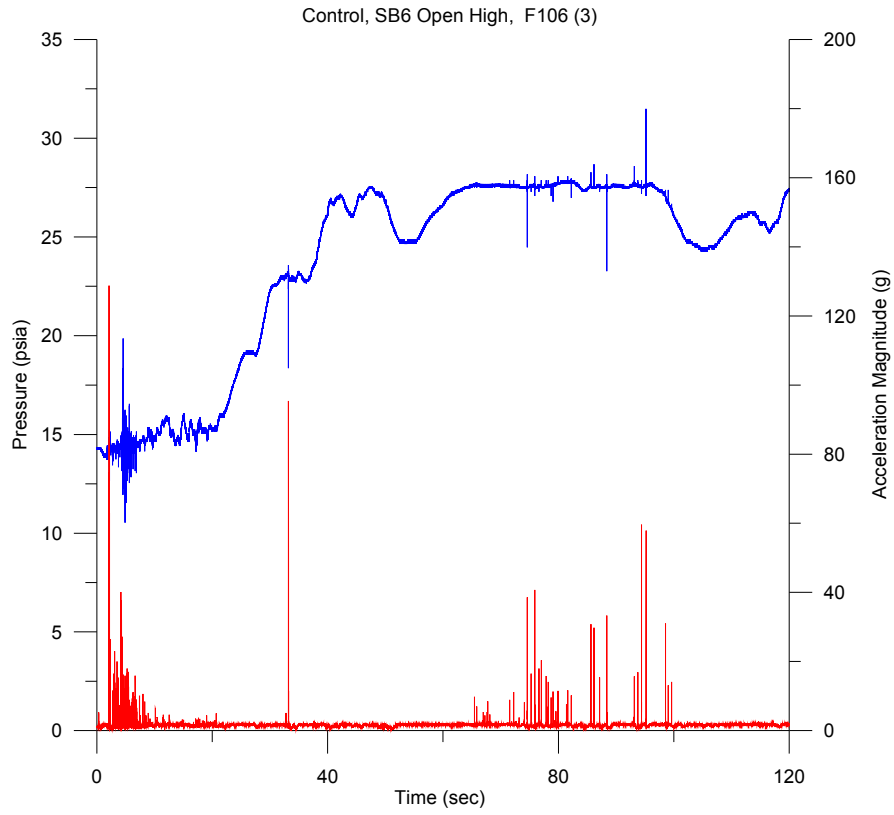


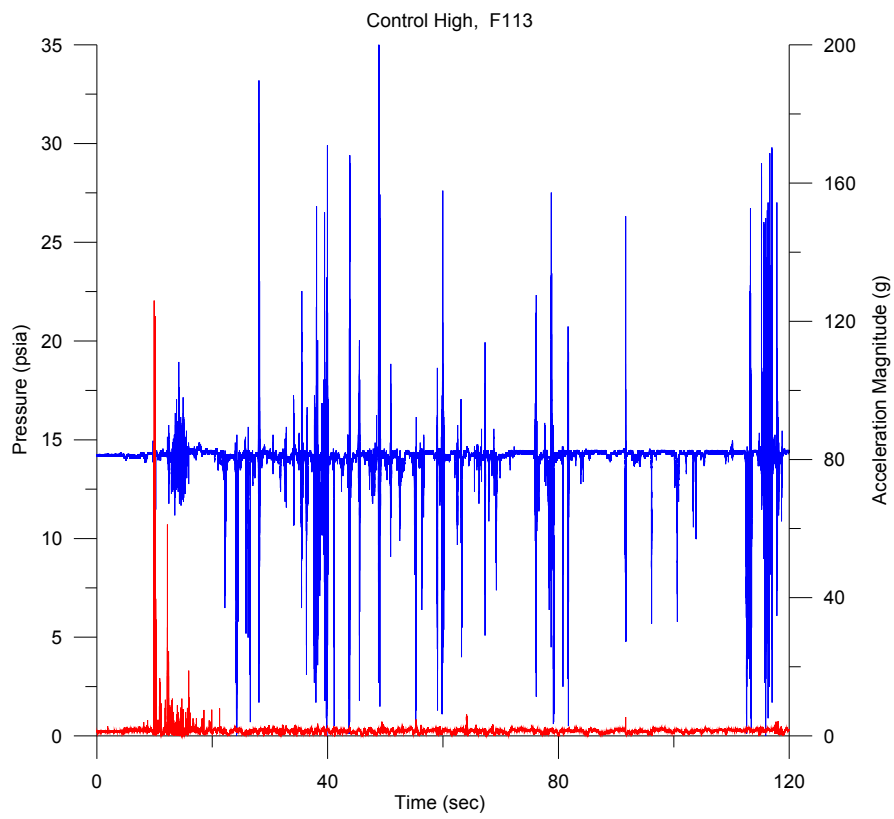
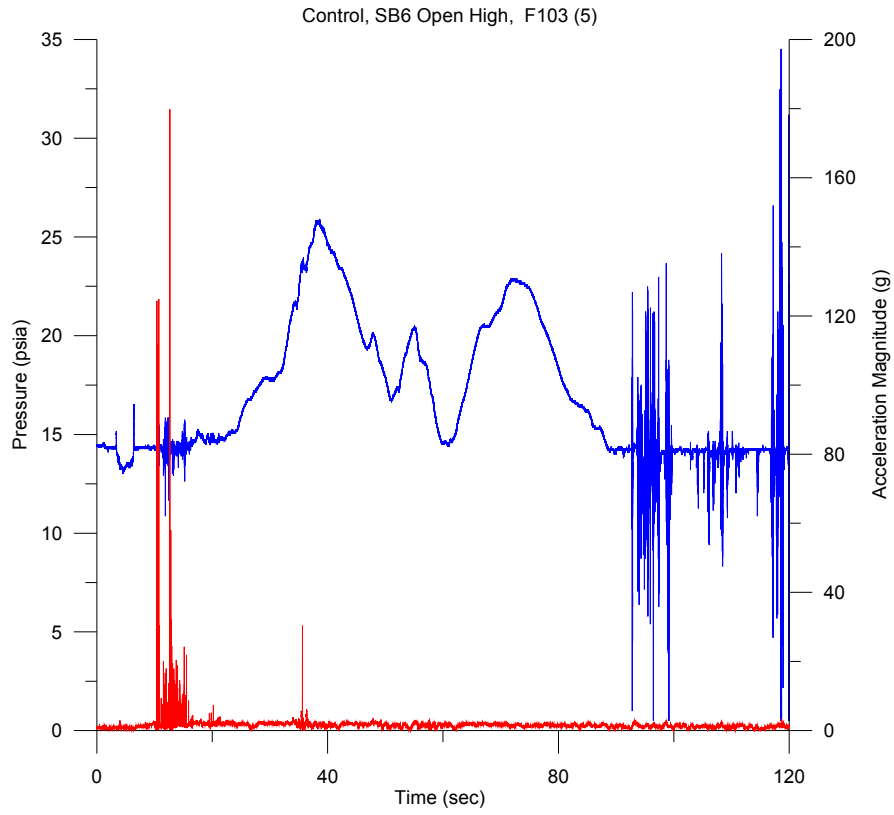
## **Detroit Dam Spillway Evaluation**

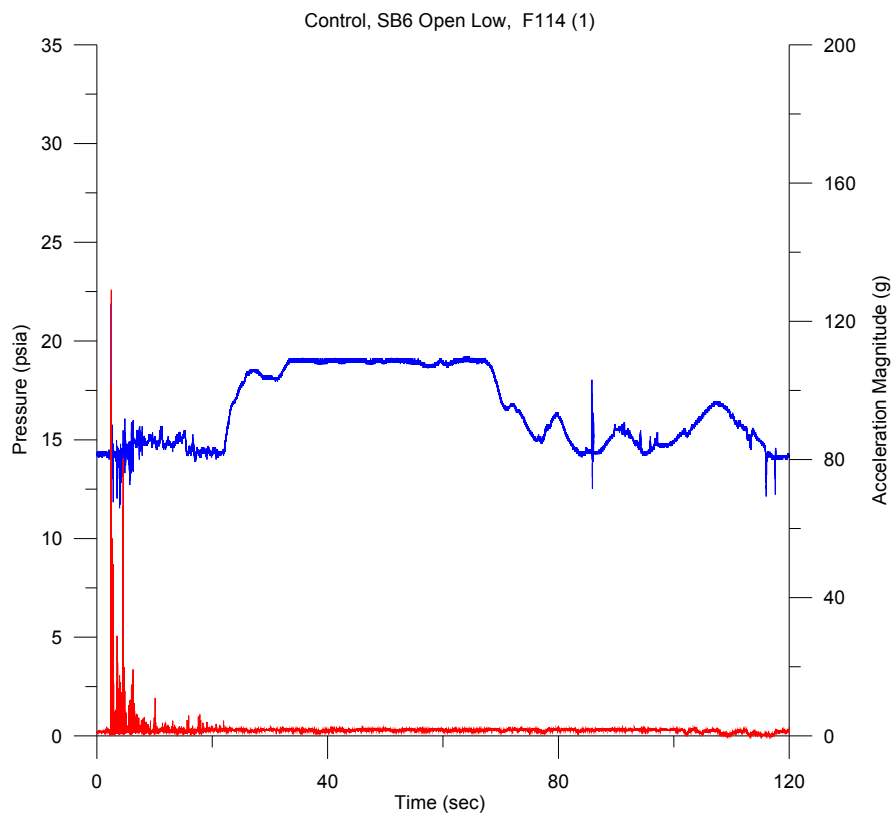
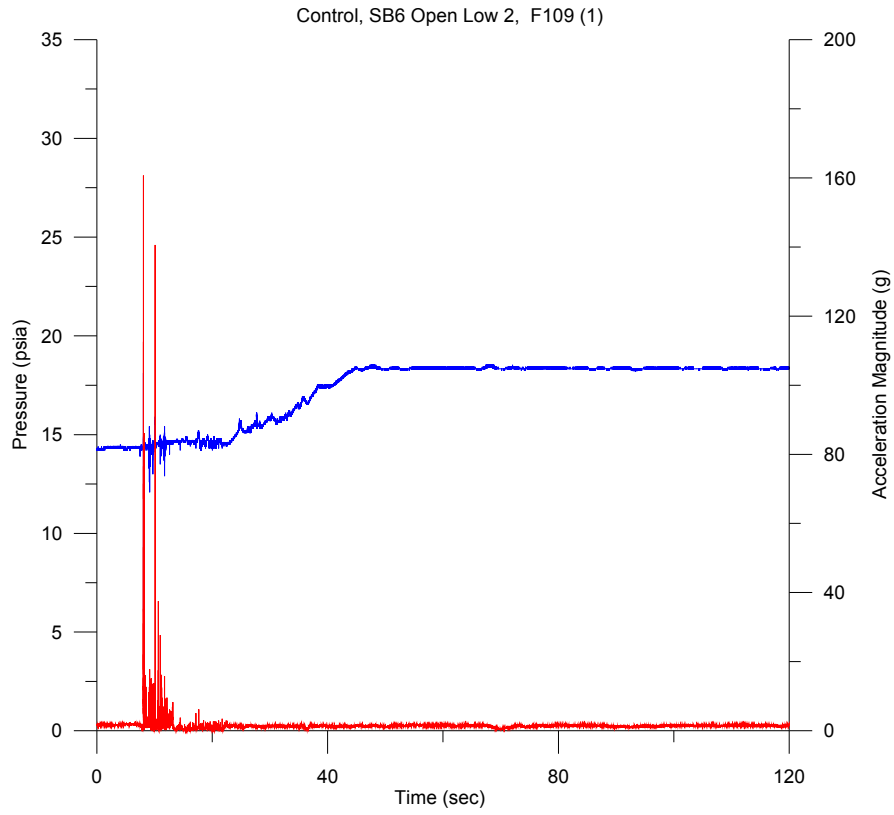
### **Controls**

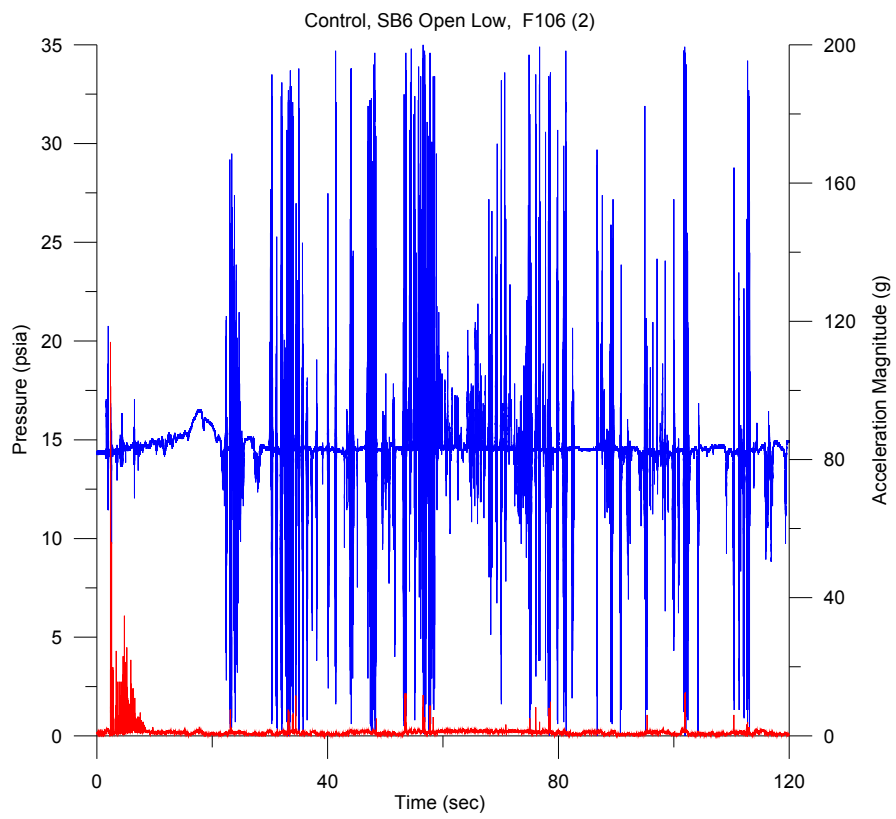
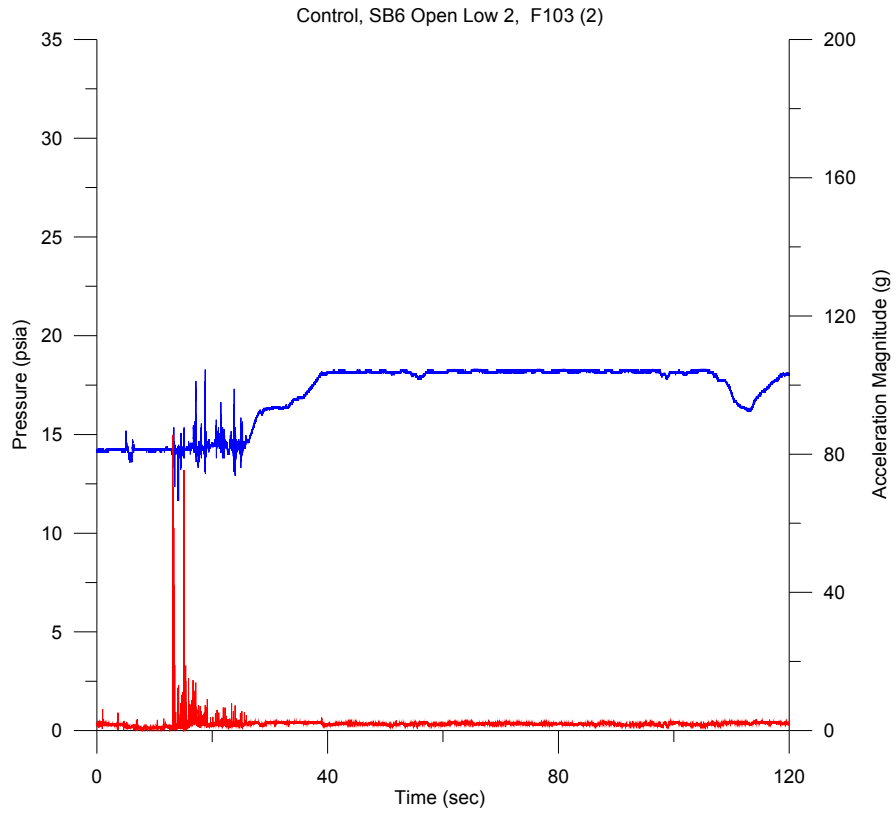




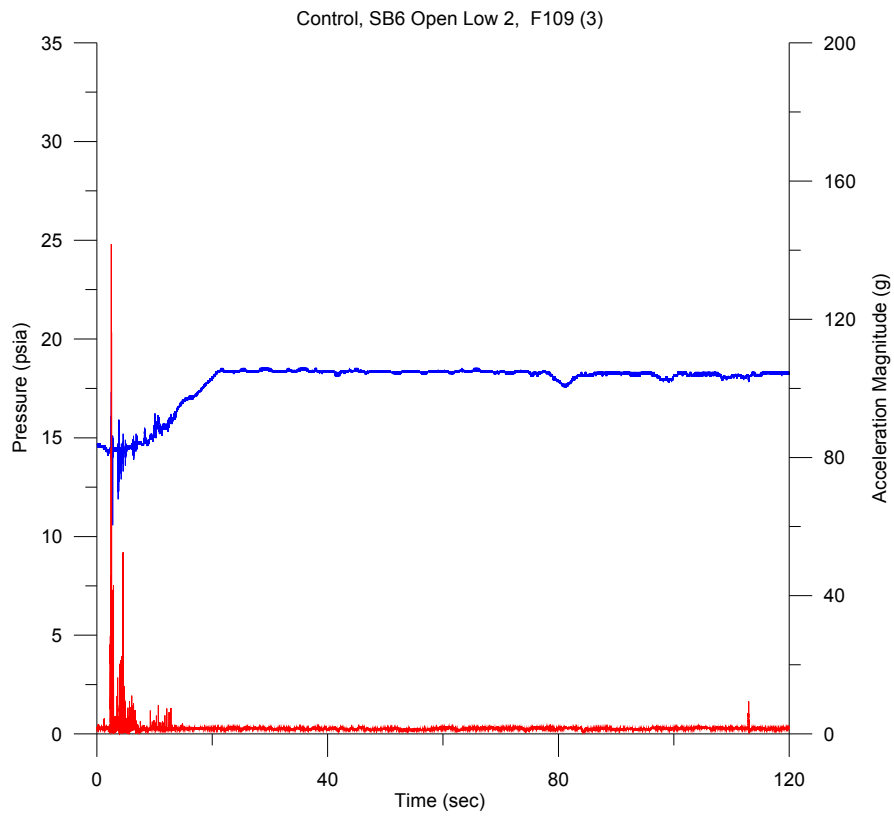
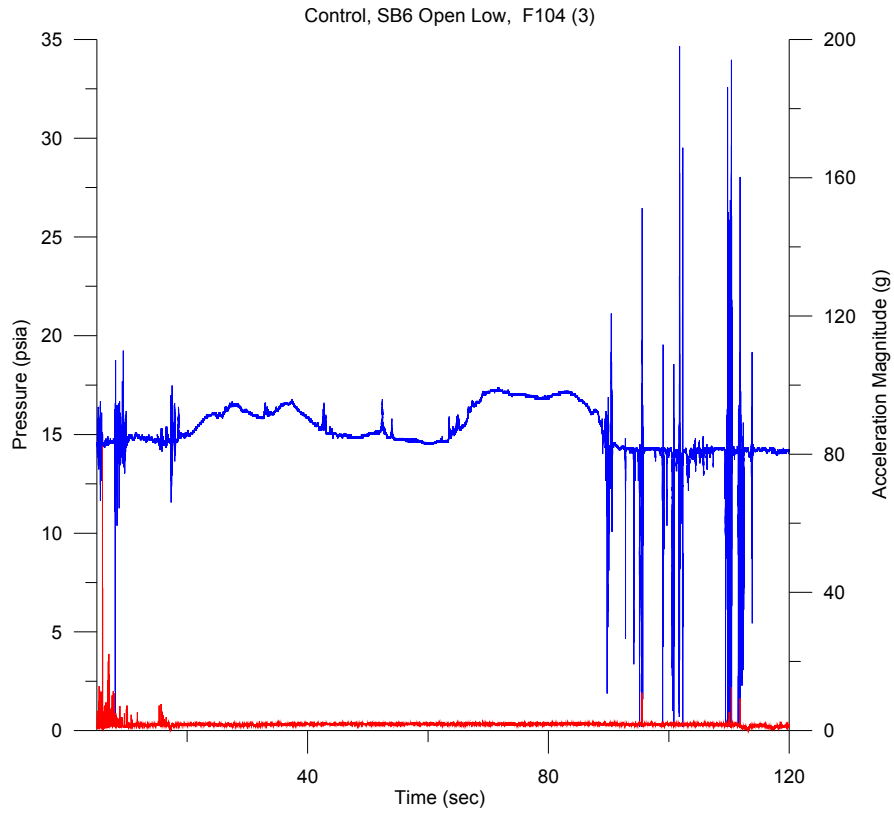


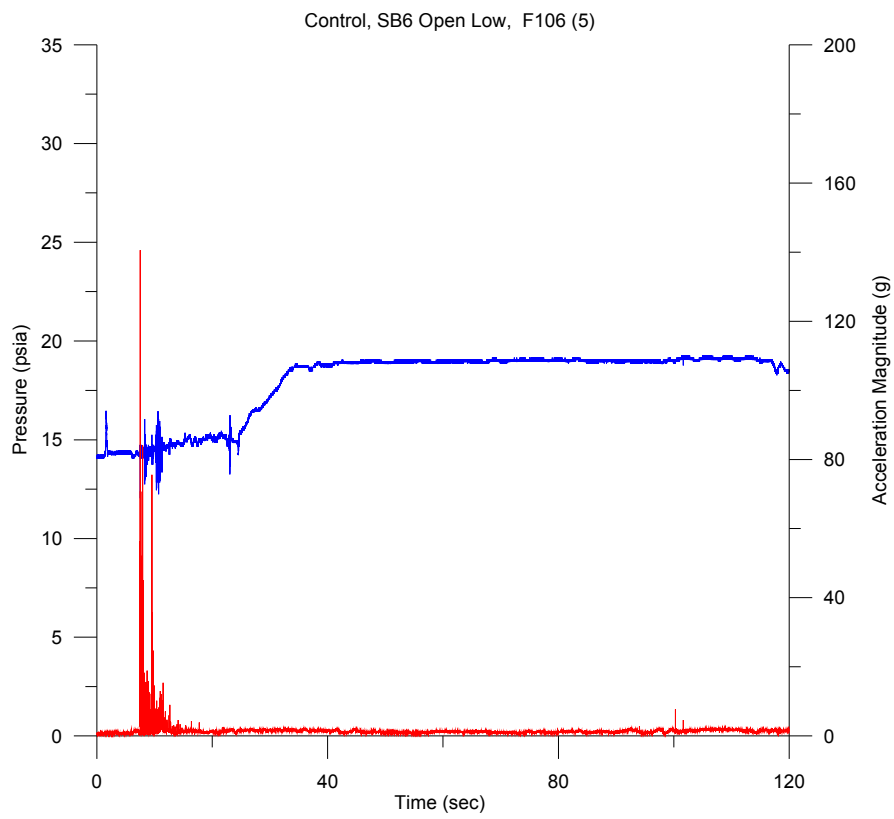
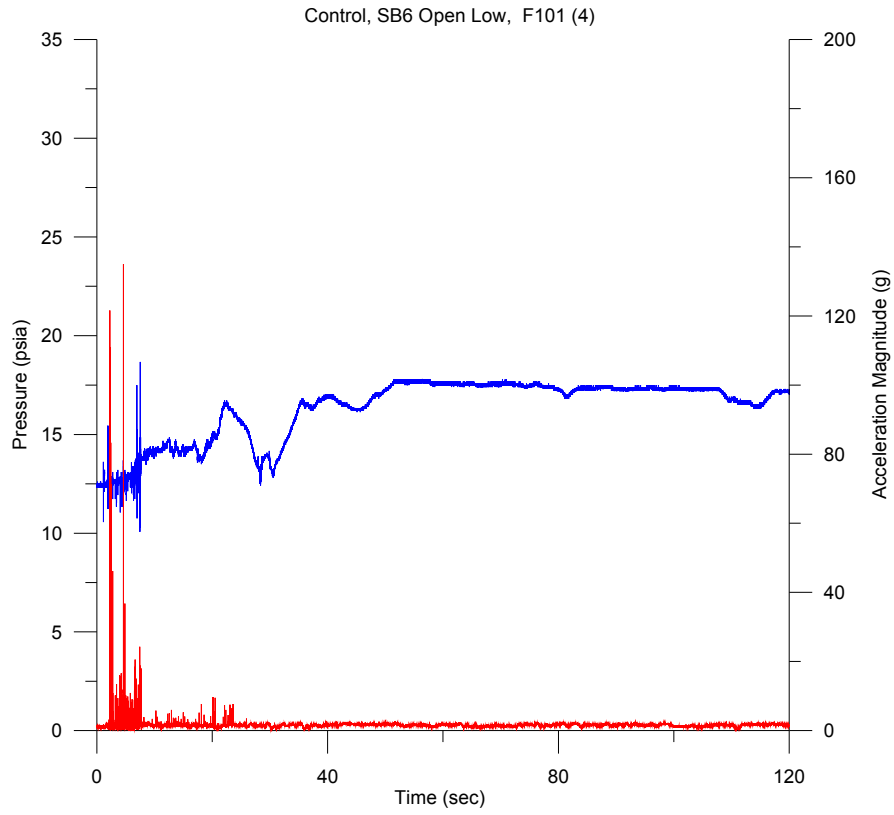


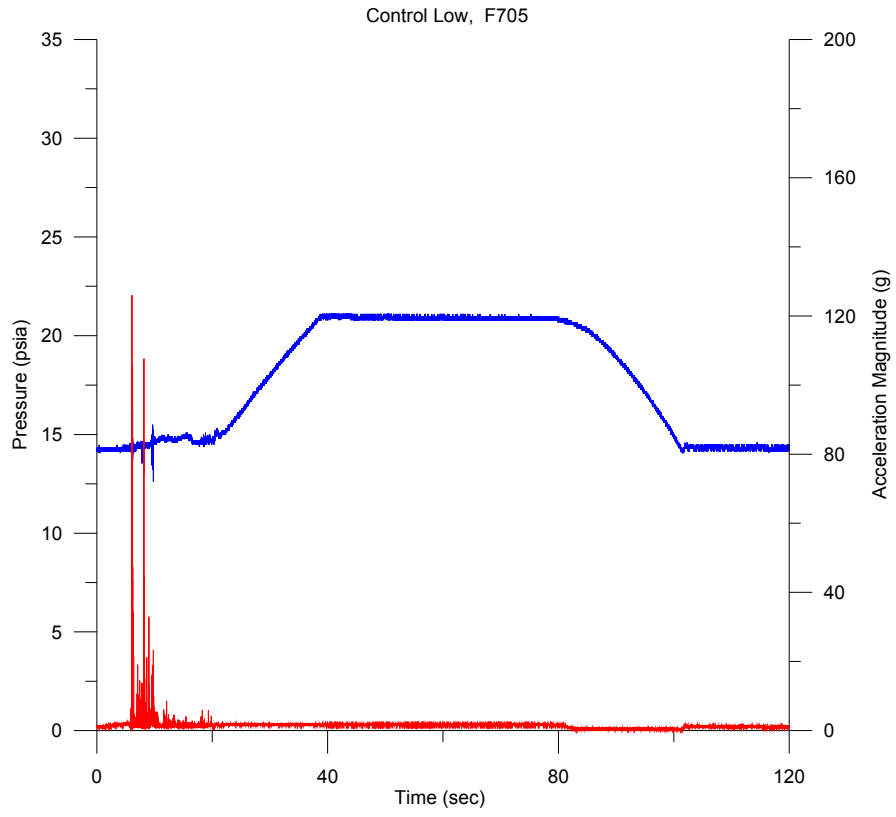




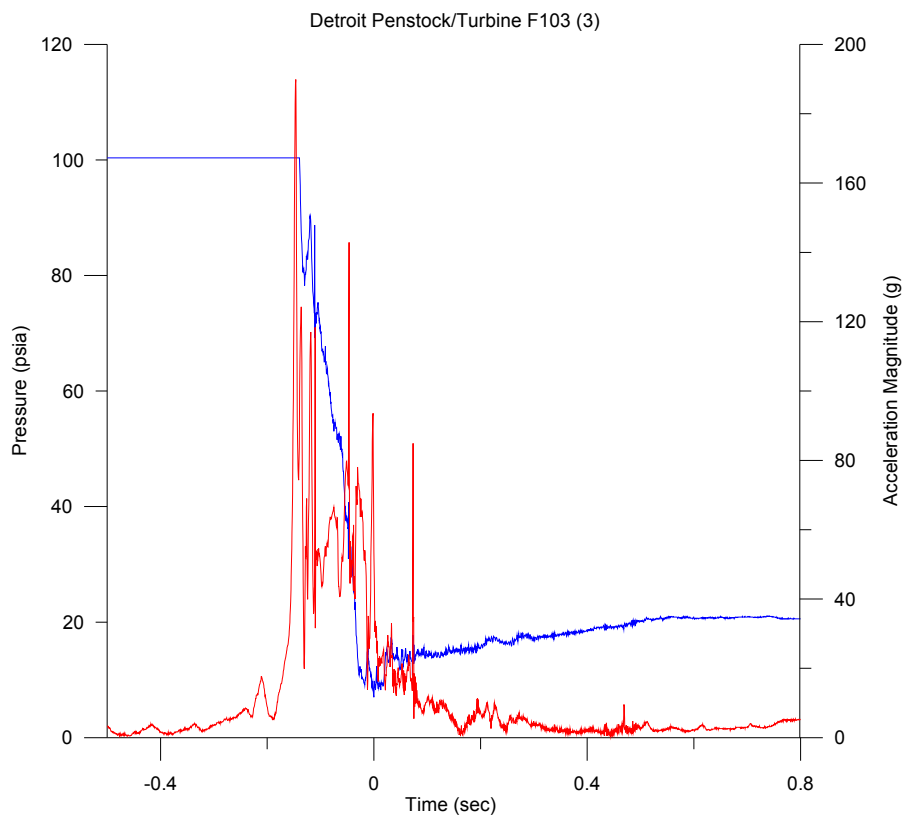
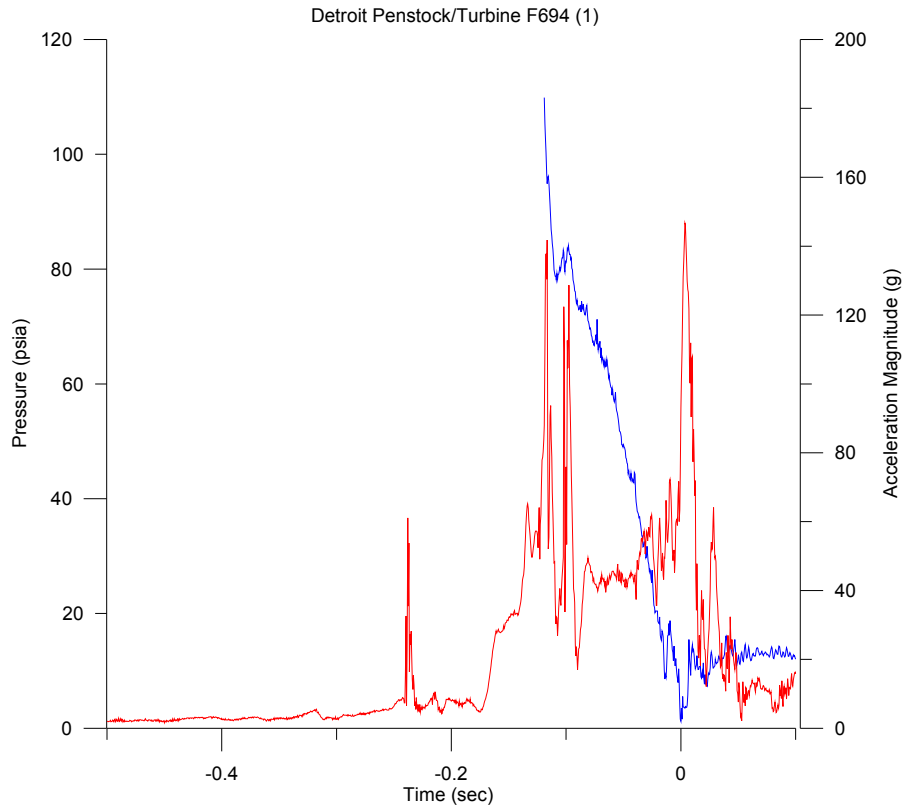


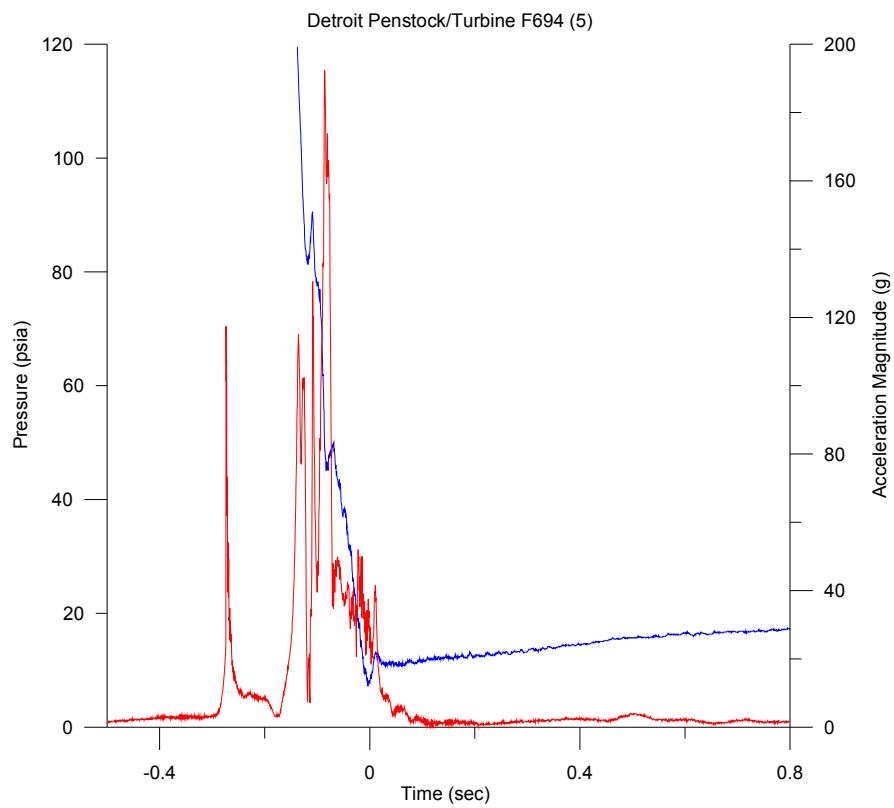
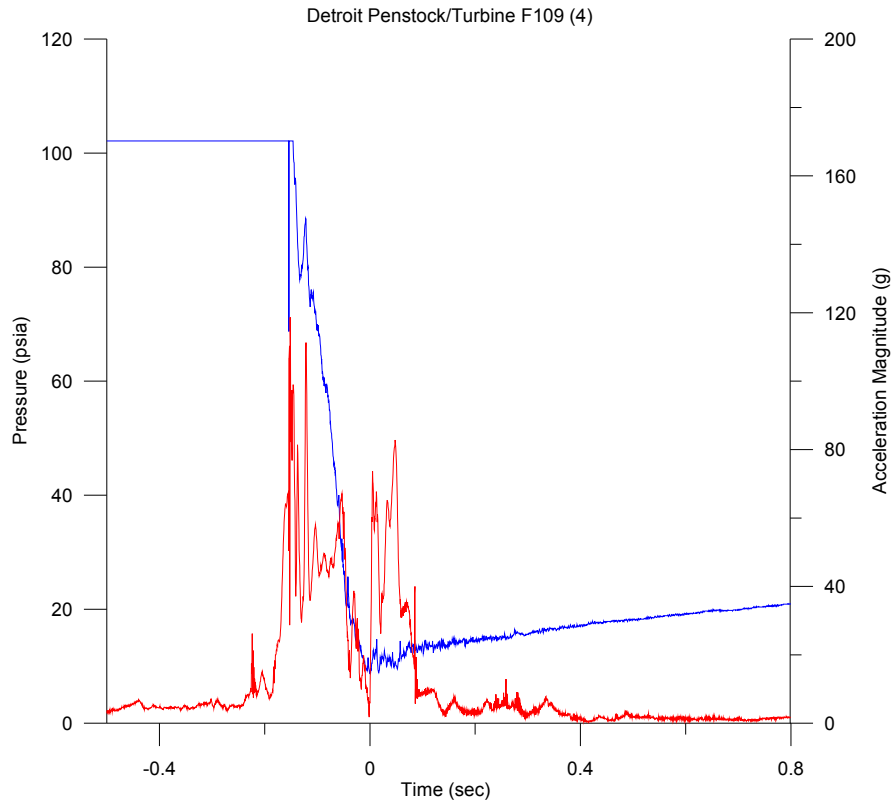


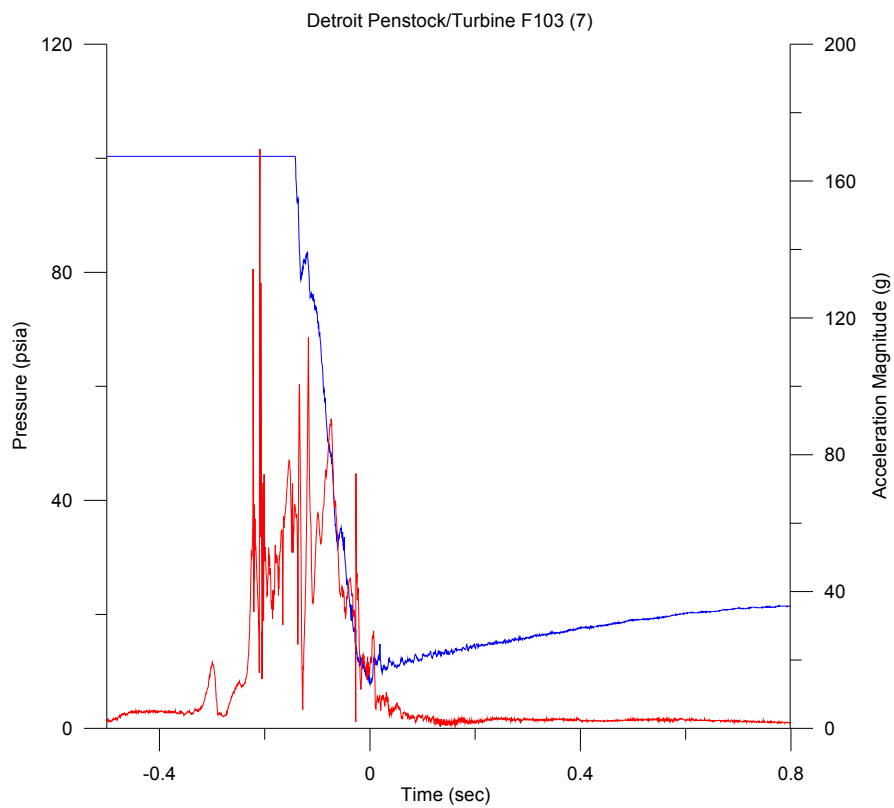
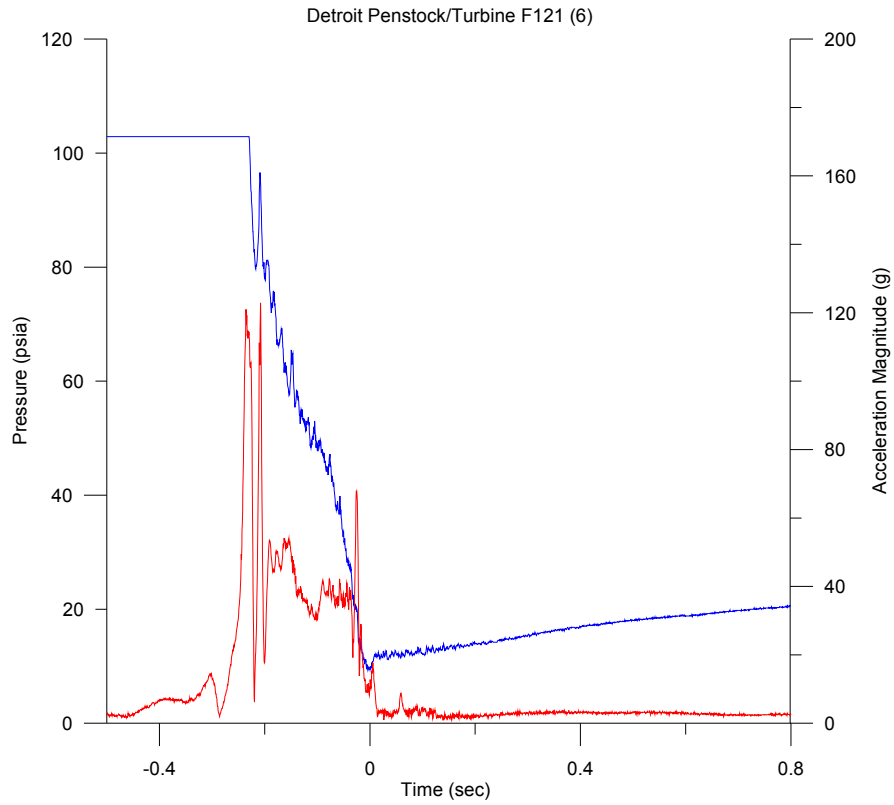


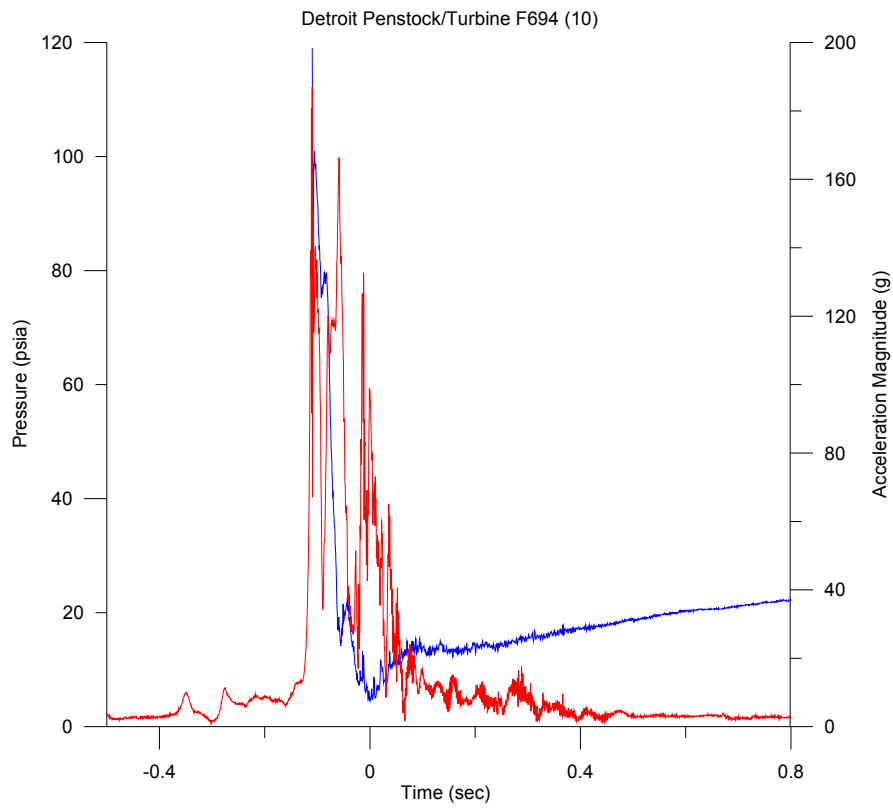
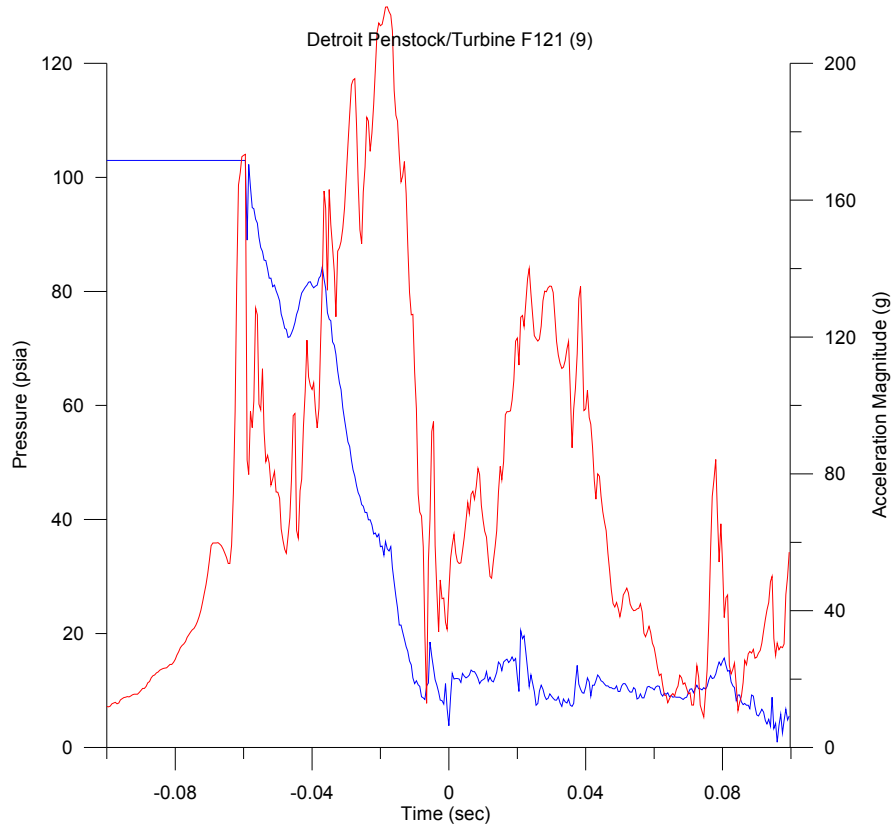


## **Detroit Dam Turbine**

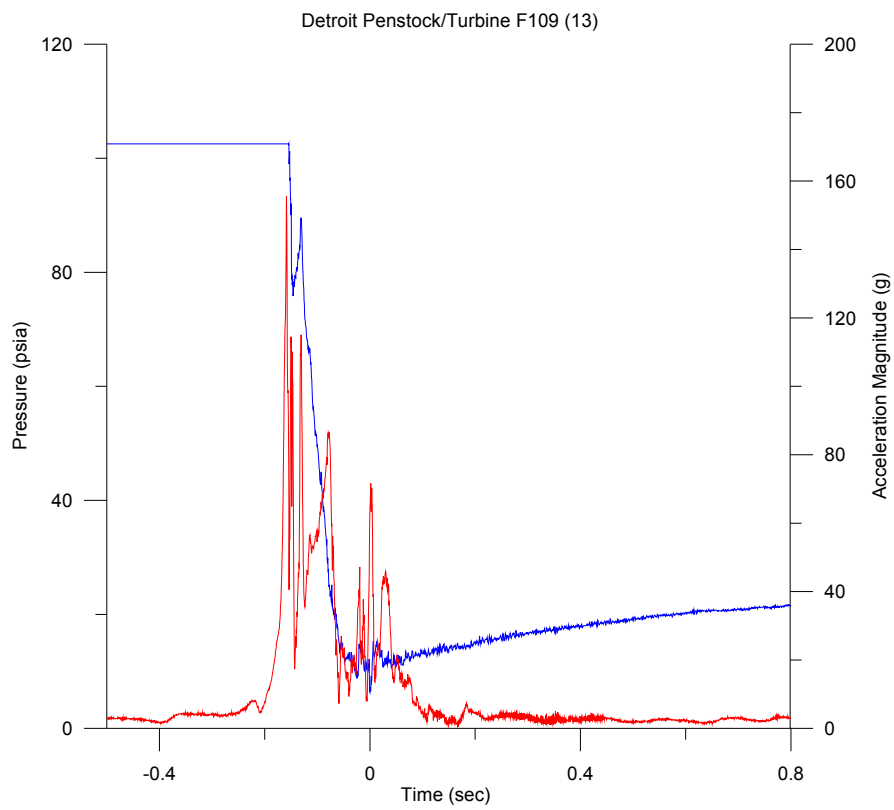
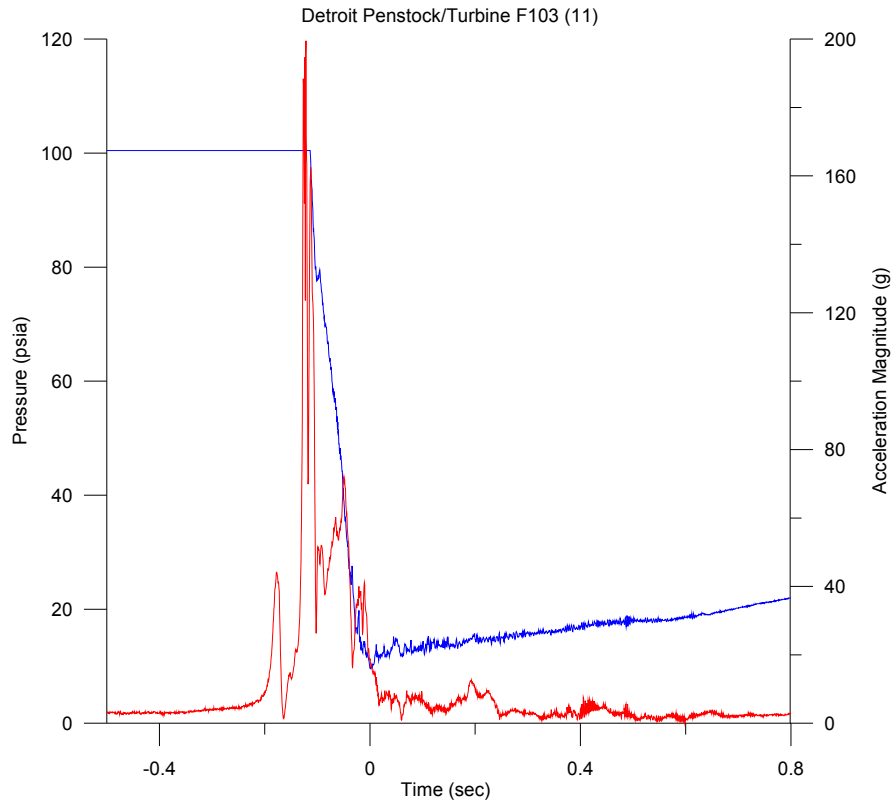


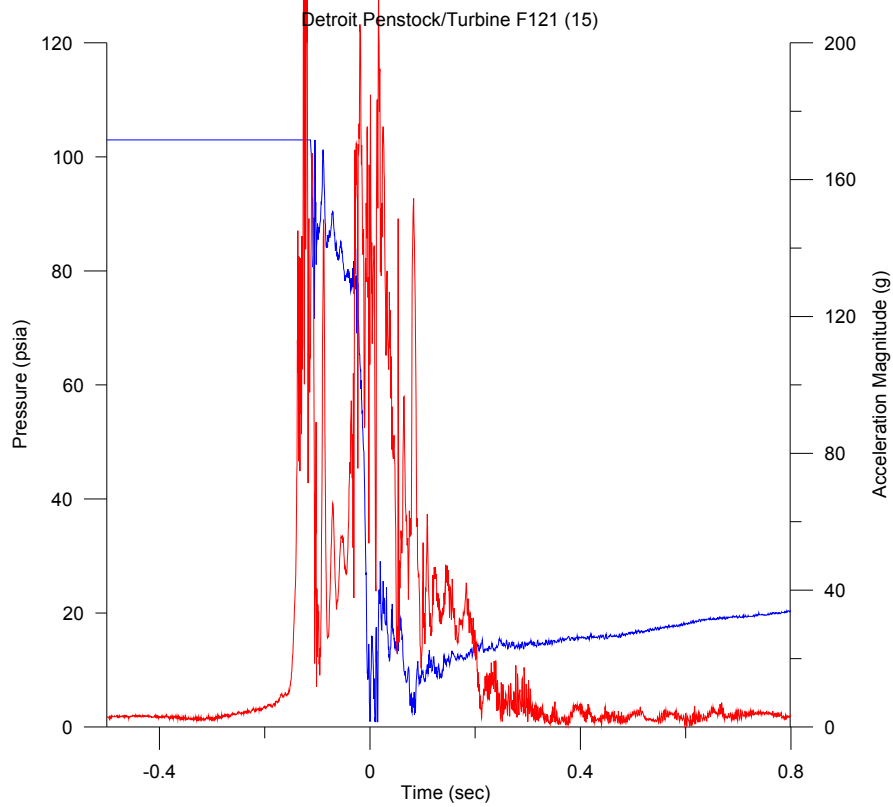
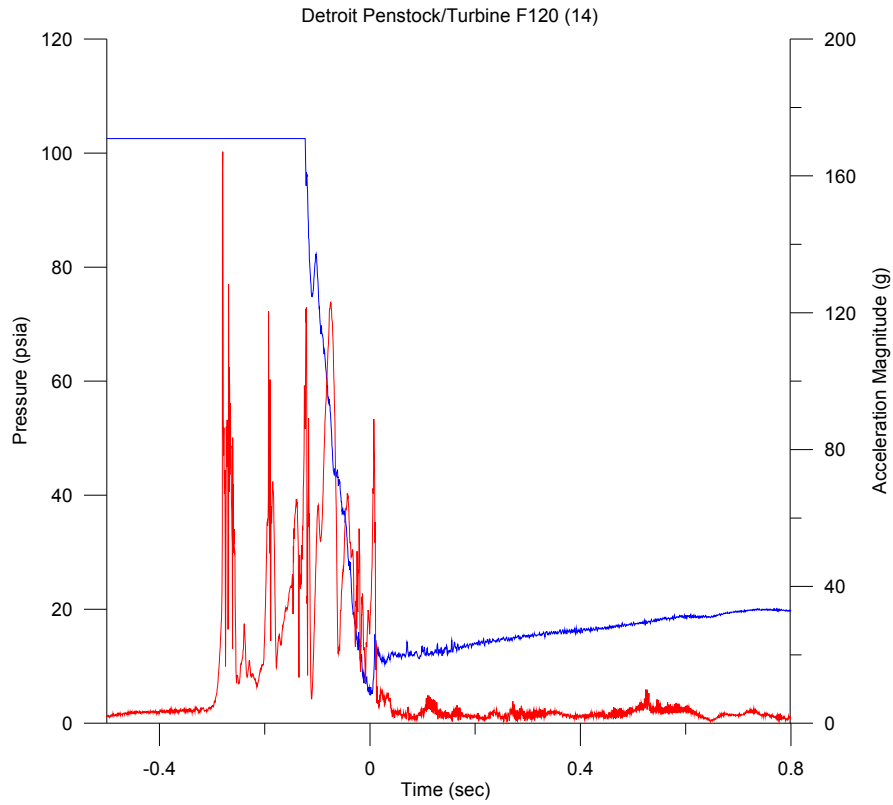


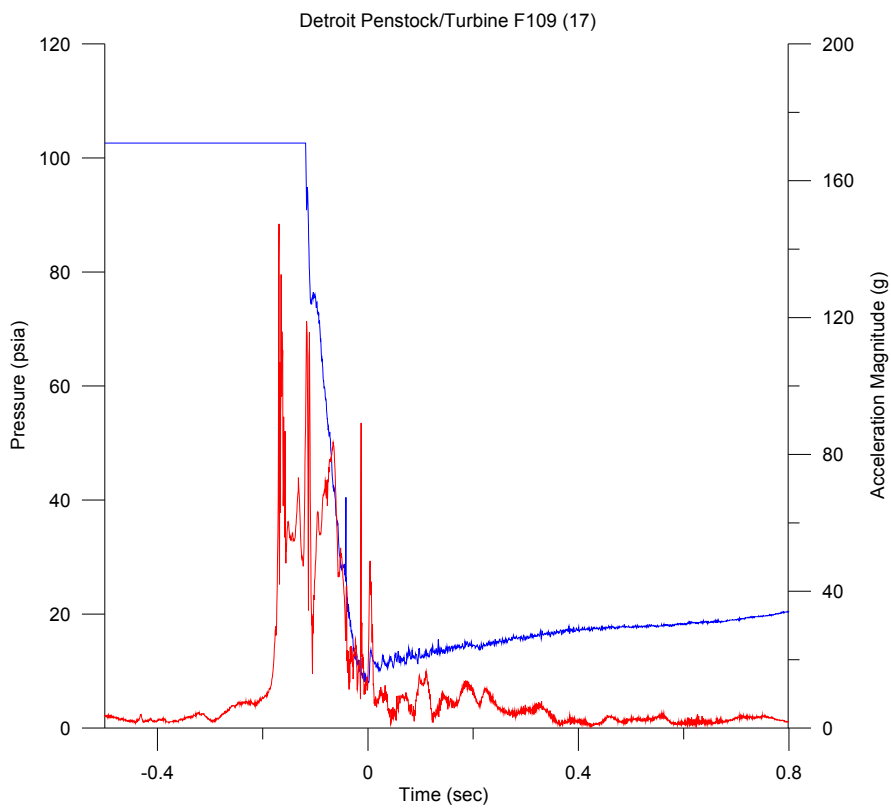
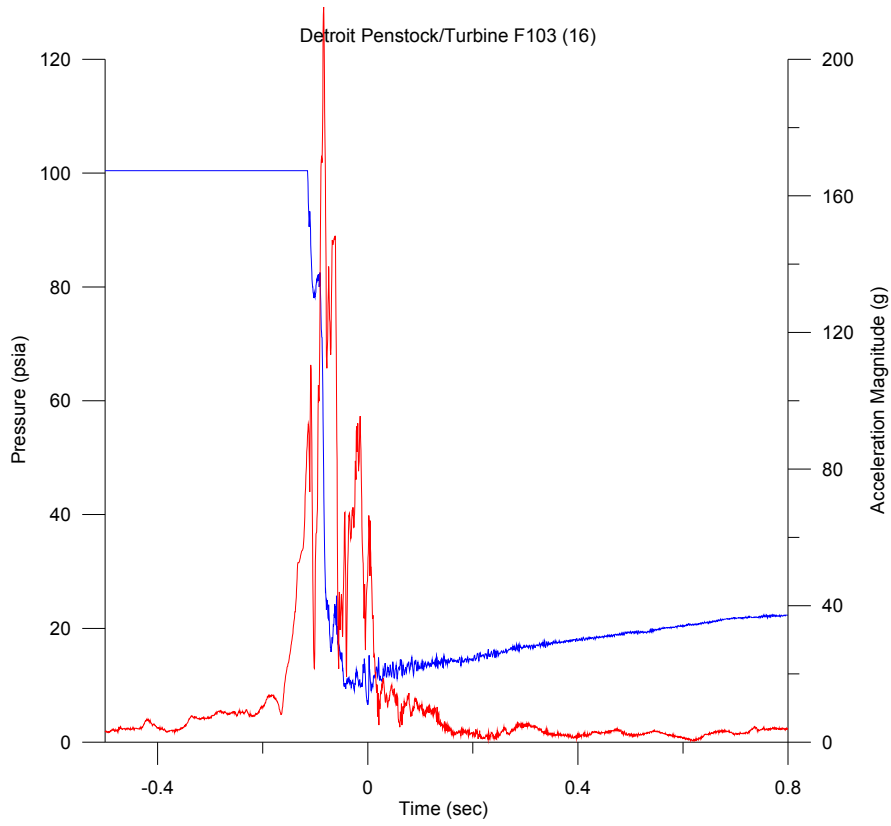


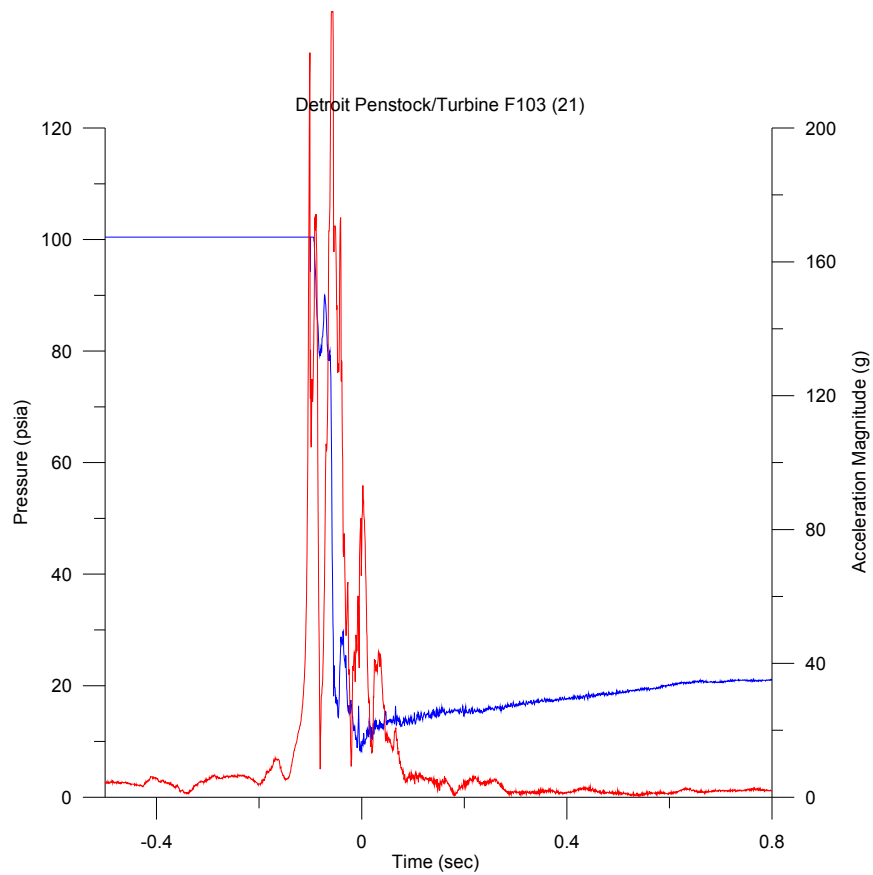
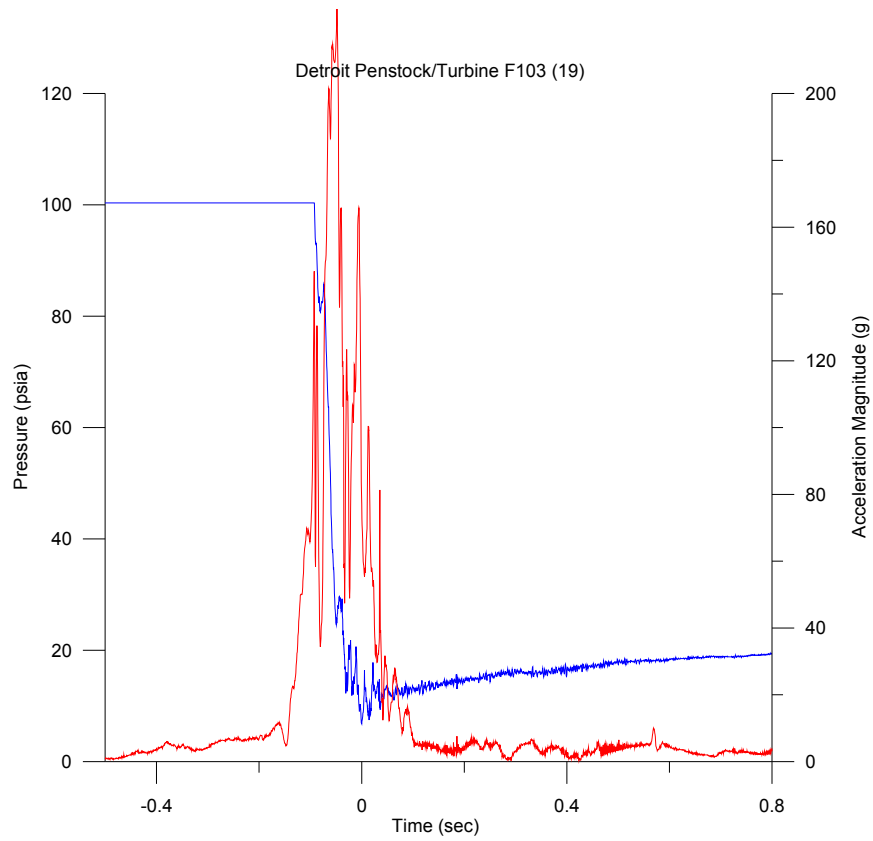


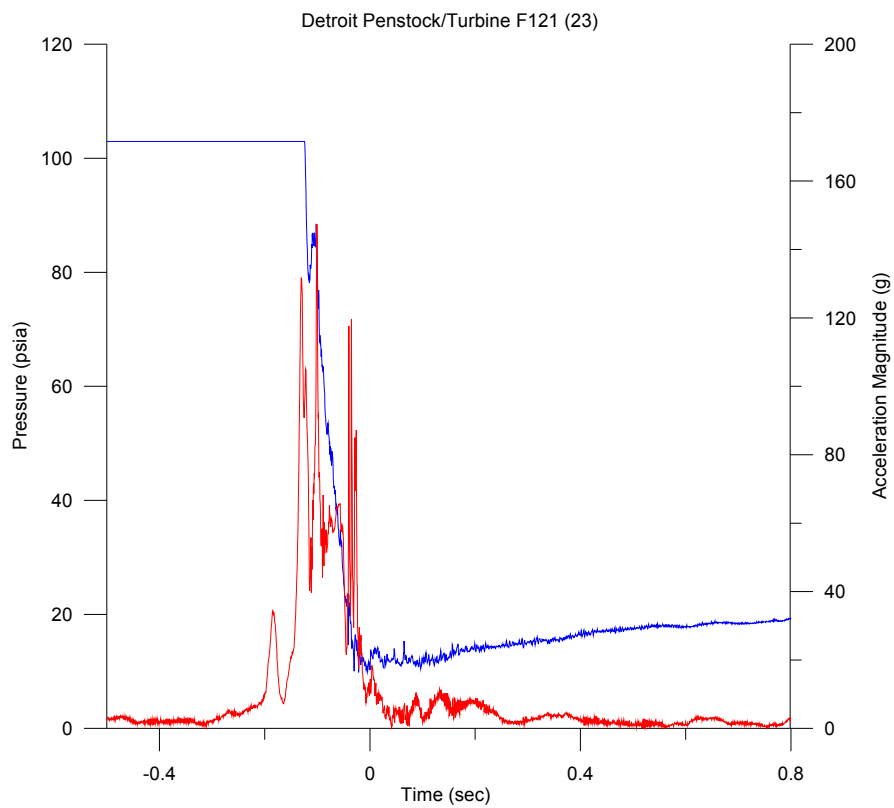
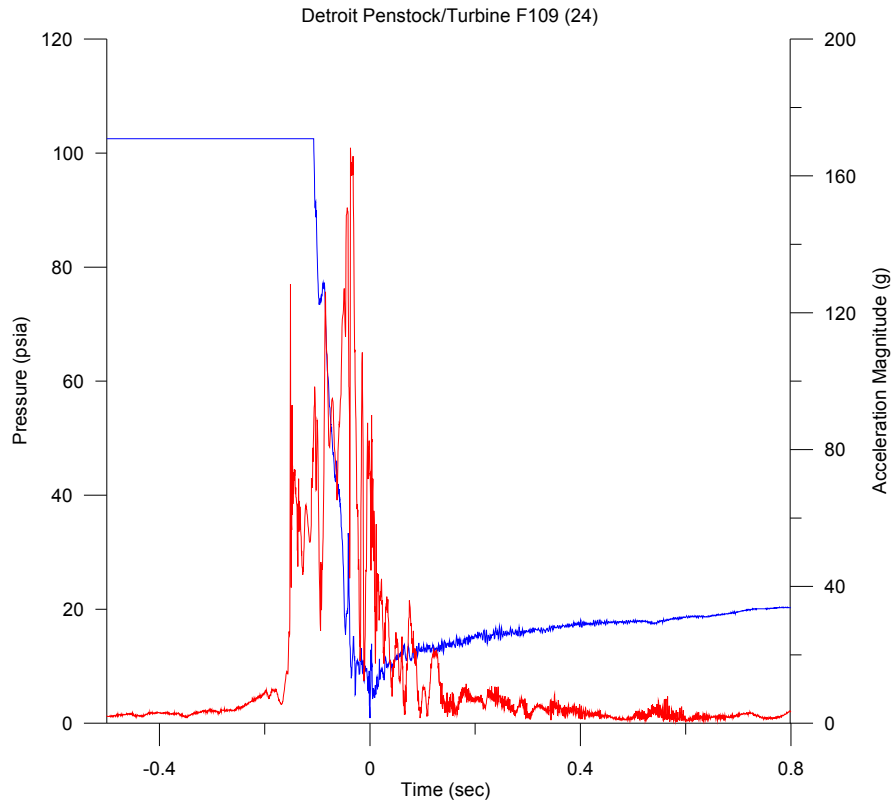


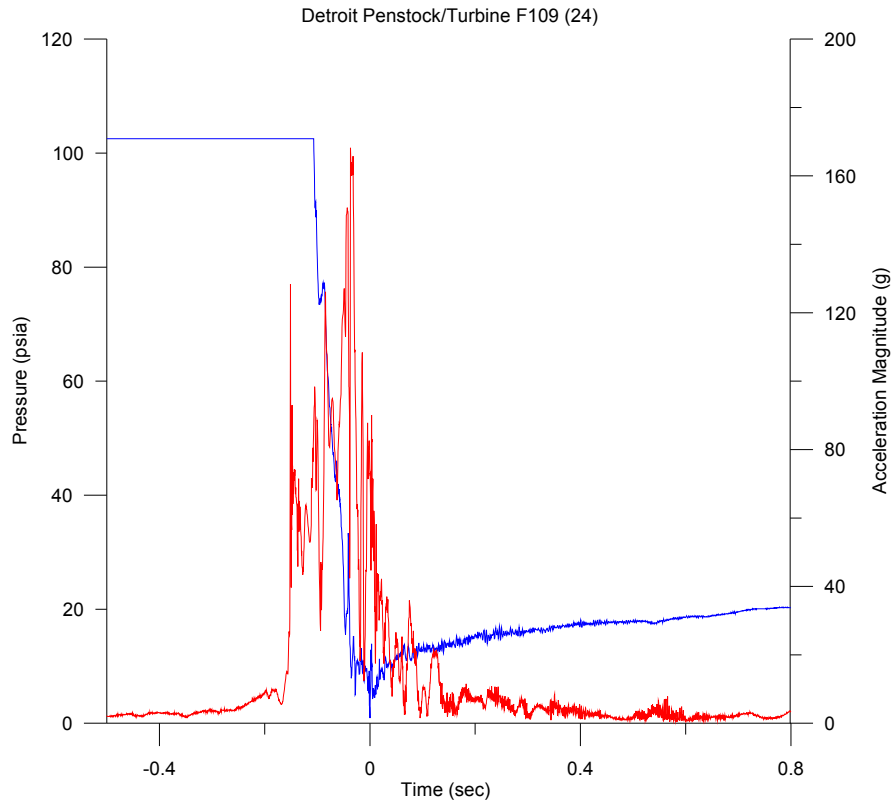






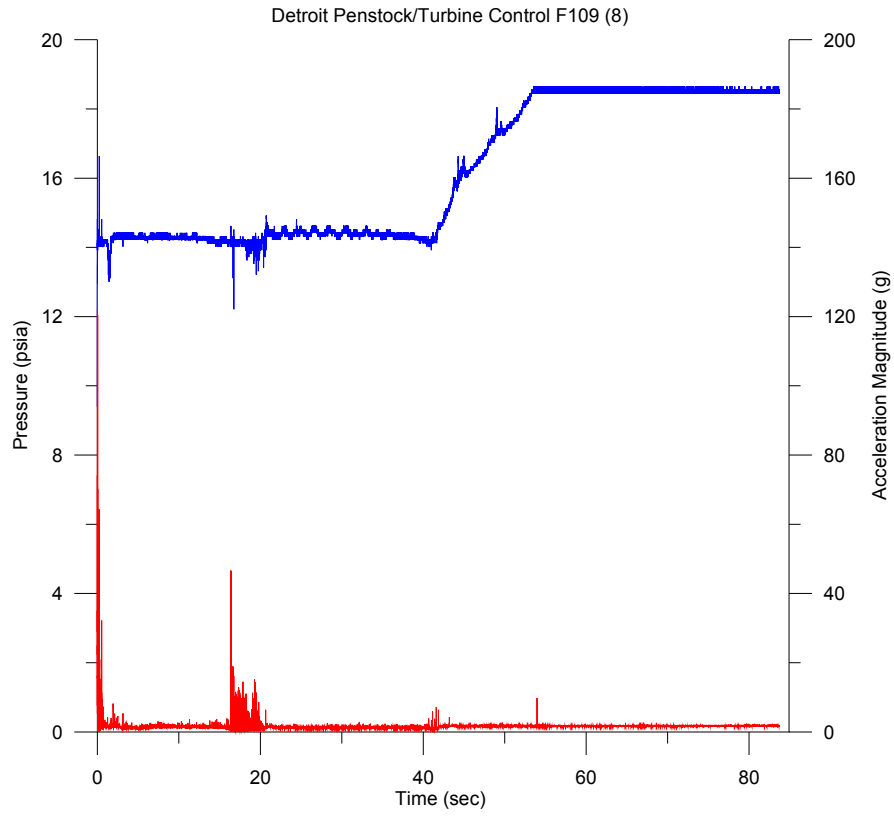






# **Detroit Dam Turbine**

## **Control**

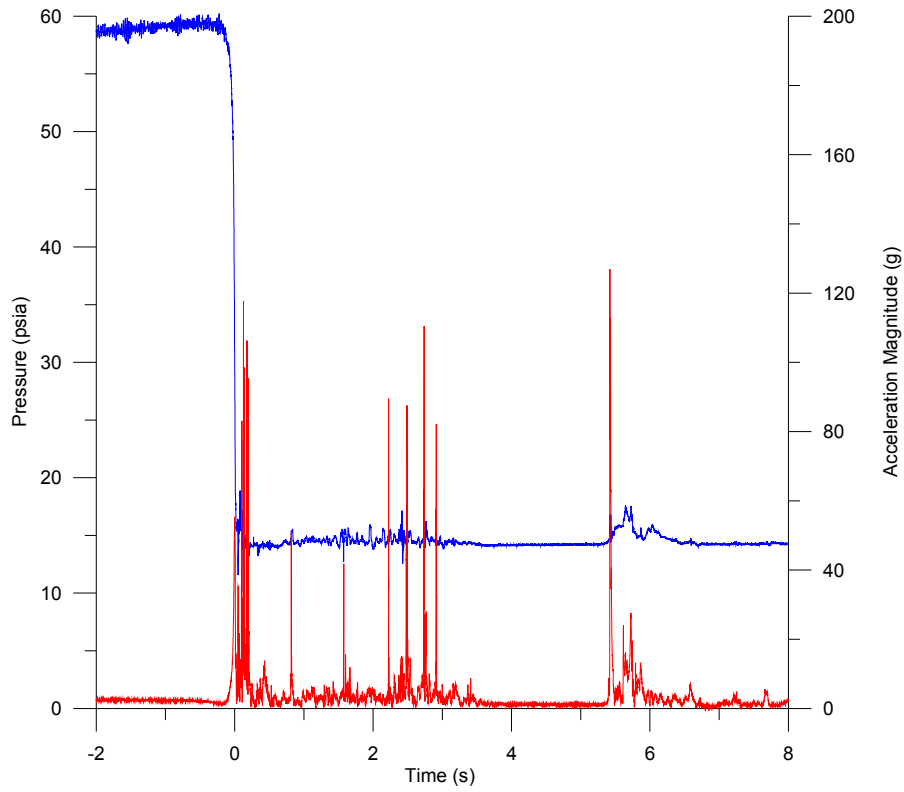




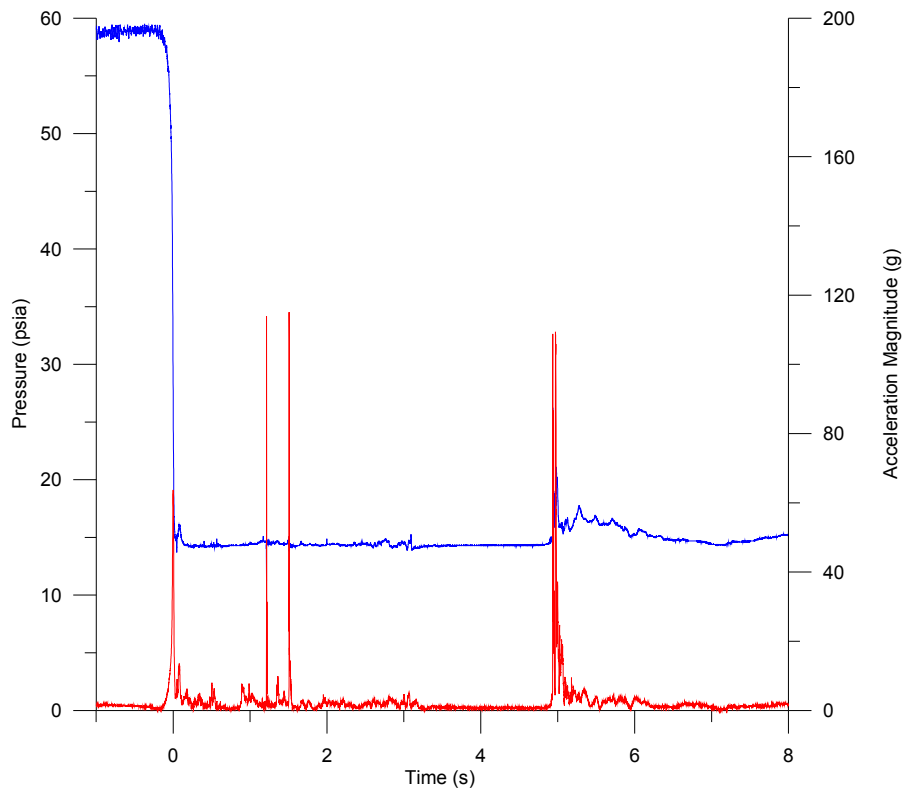
## **Detroit Dam Regulating Outlet**

### **1-ft Gate Opening**

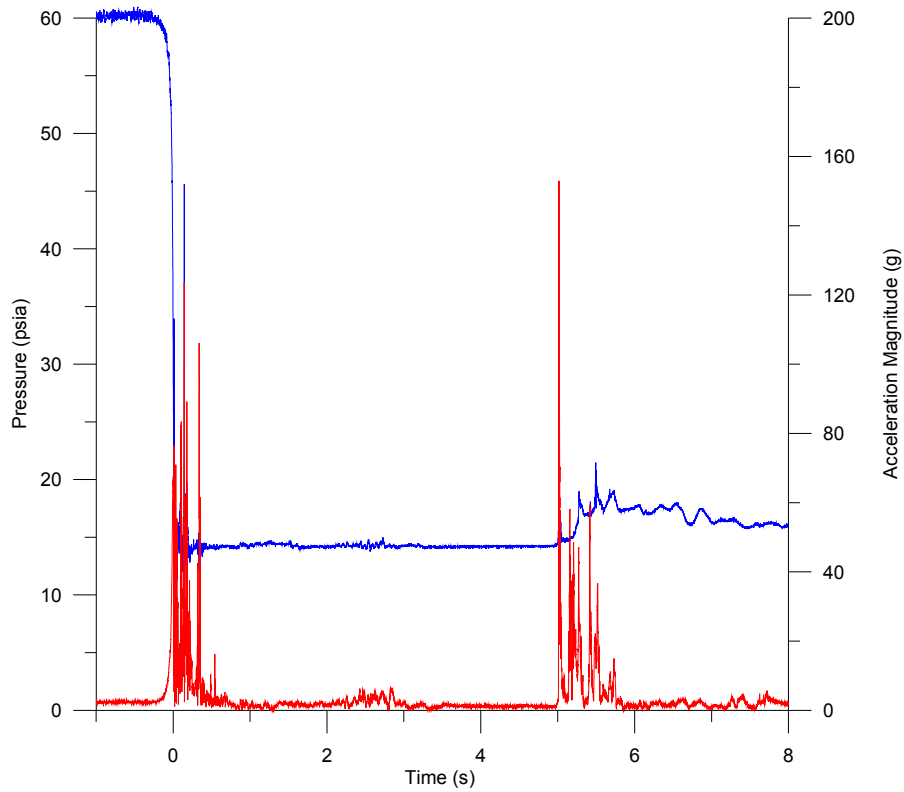
Detroit Dam RO 1 ft Opening, F103(1)



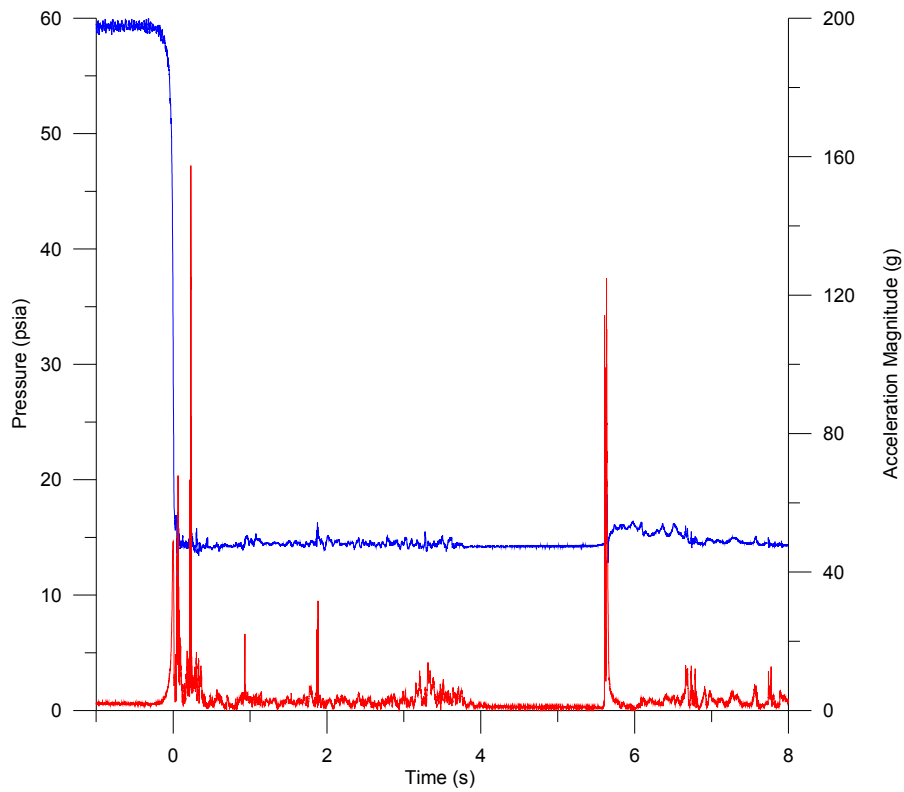
Detroit Dam RO 1 ft Opening, F923 (2)



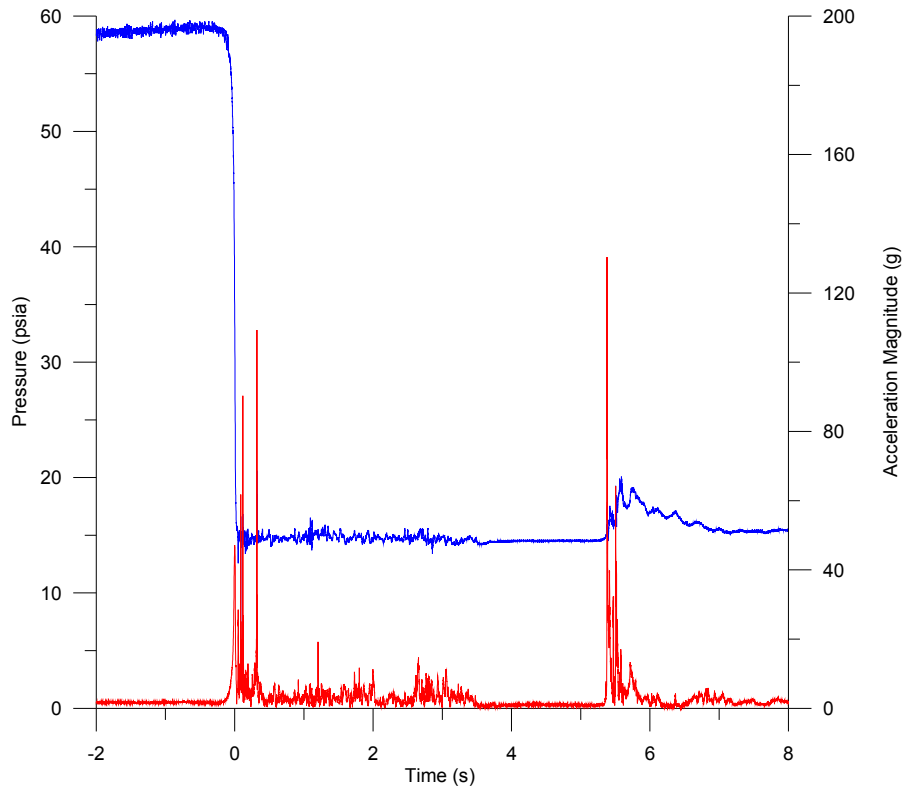
Detroit Dam RO 1 ft Opening, F121 (3)



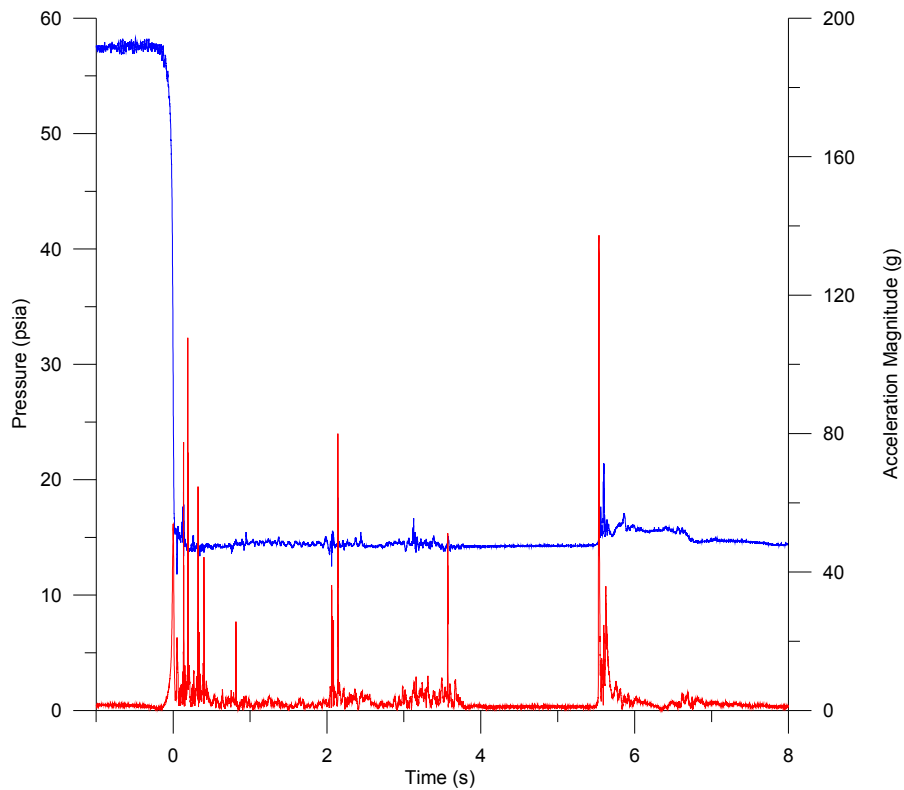
Detroit Dam RO 1 ft Opening, F109 (4)



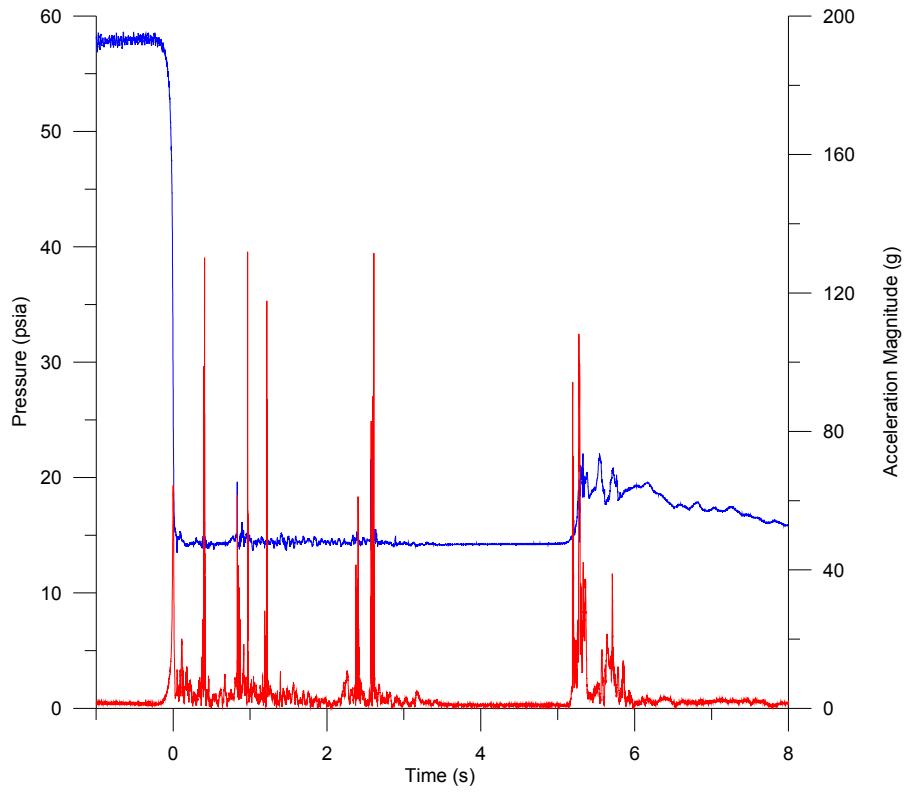
Detroit Dam RO 1 ft Opening, F930 (5)



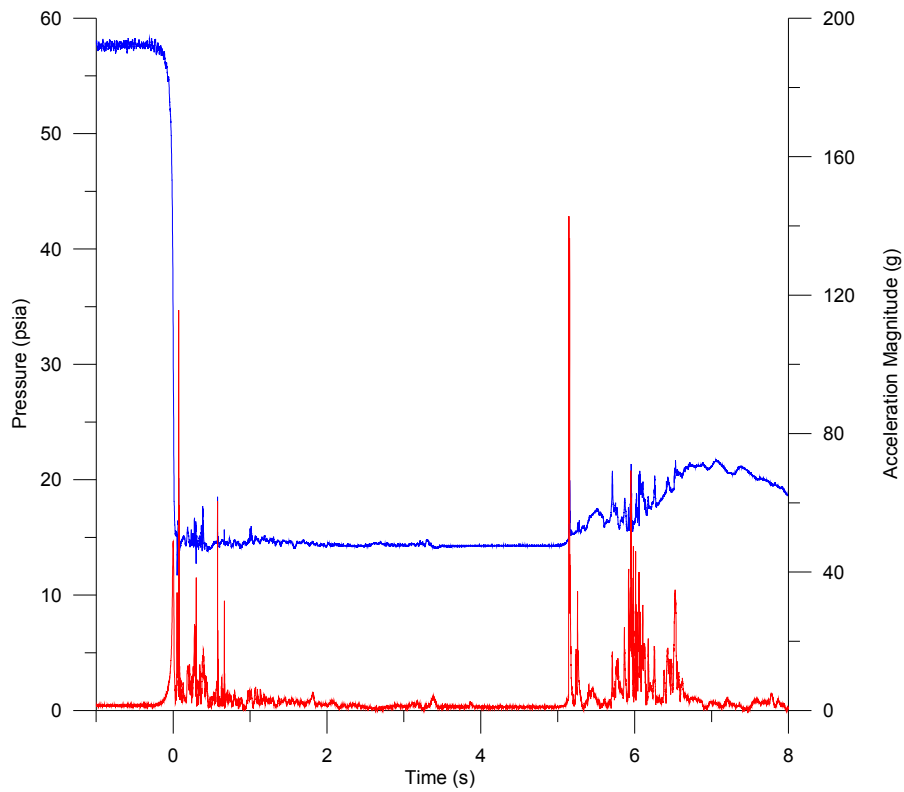
Detroit Dam RO 1 ft Opening, F931 (6)



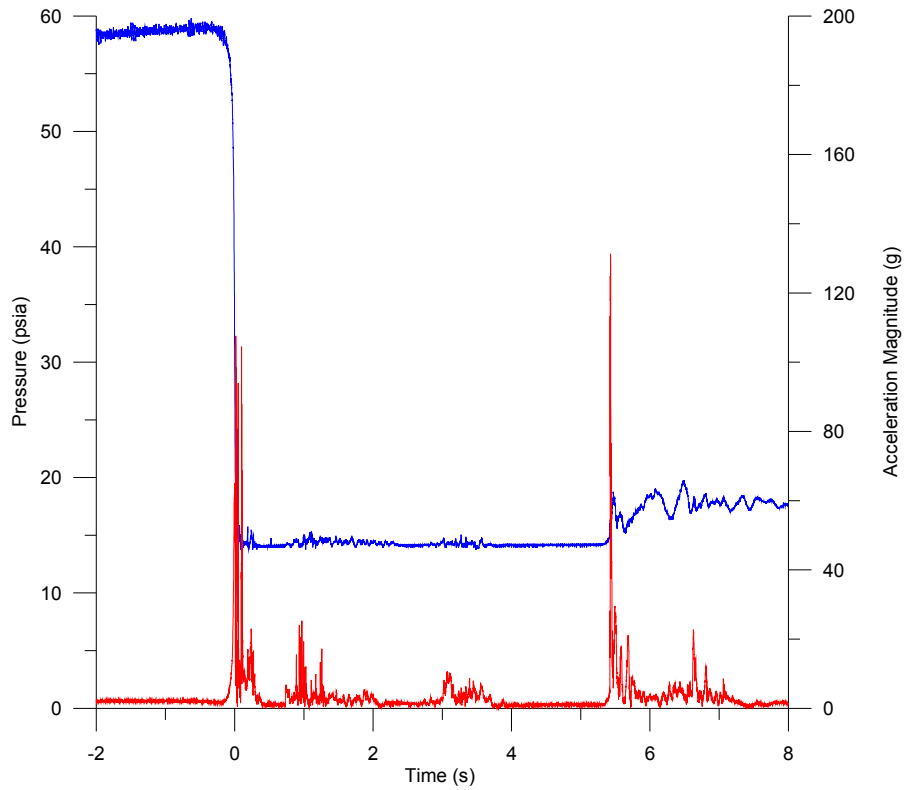
Detroit Dam RO 1 ft Opening, F908 (7)



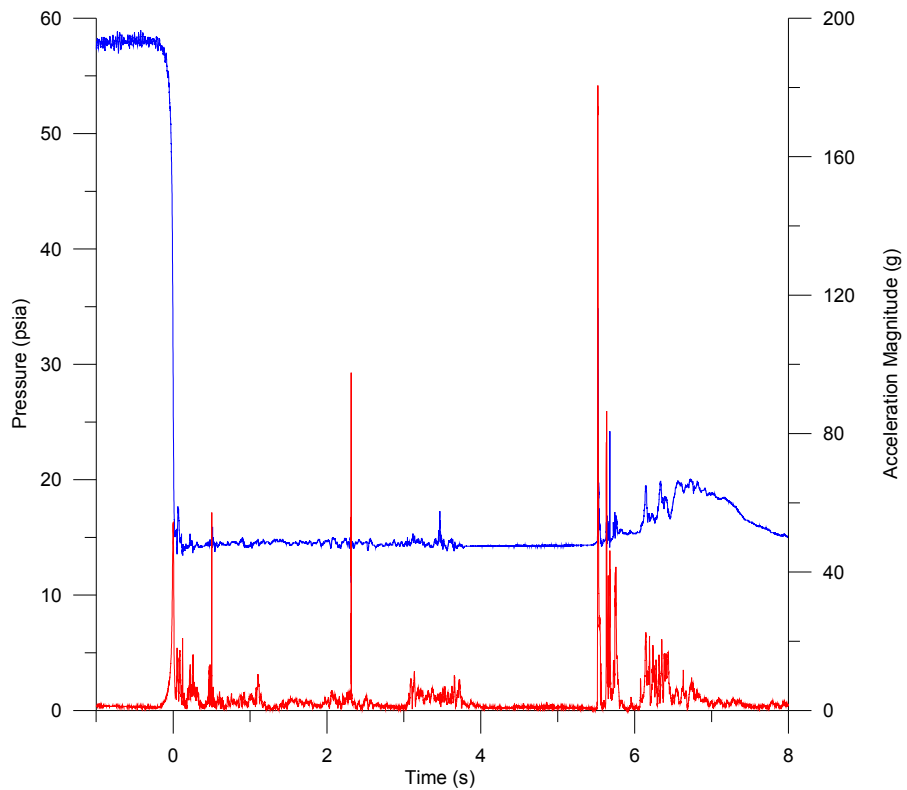
Detroit Dam RO 1 ft Opening, F930 (8)



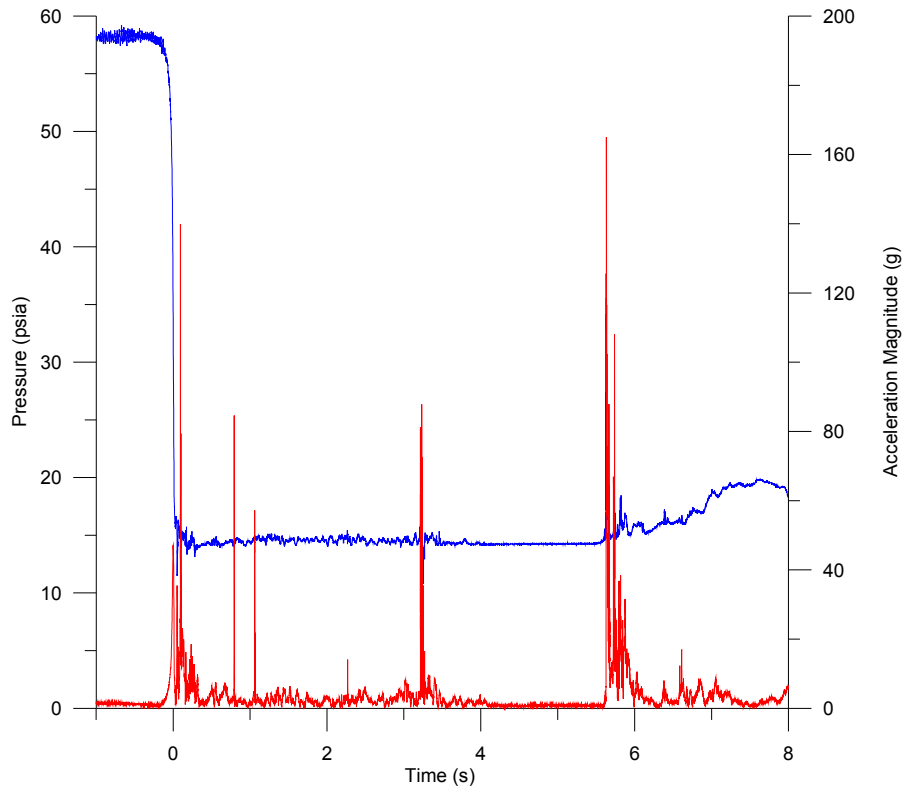
Detroit Dam RO 1 ft Opening, F121 (9)



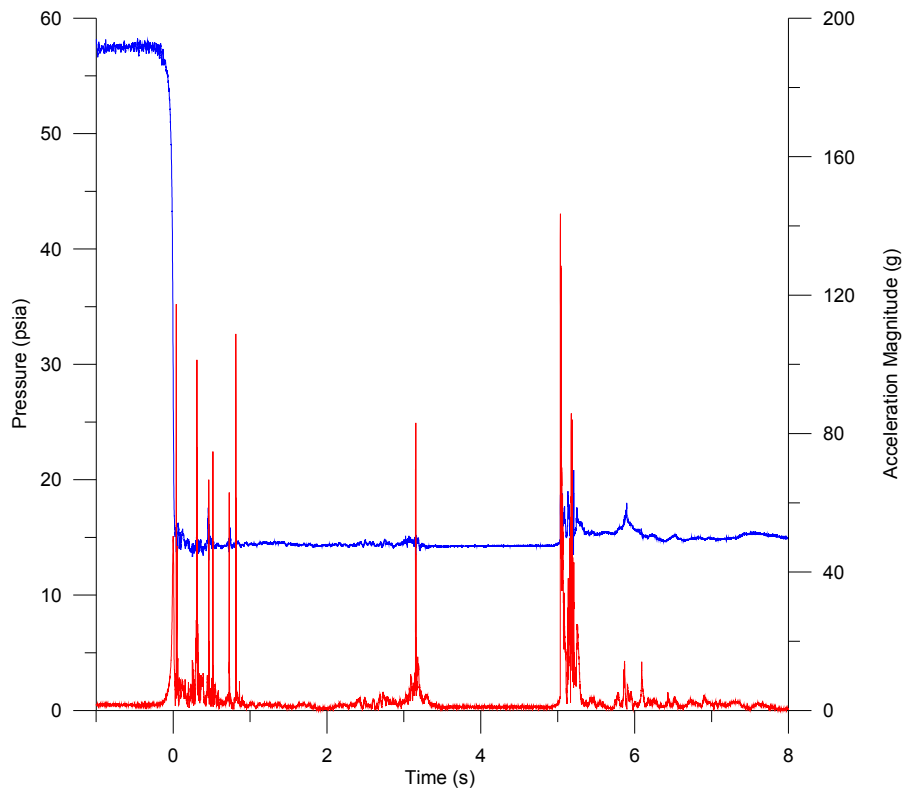
Detroit Dam RO 1 ft Opening, F923 (10)



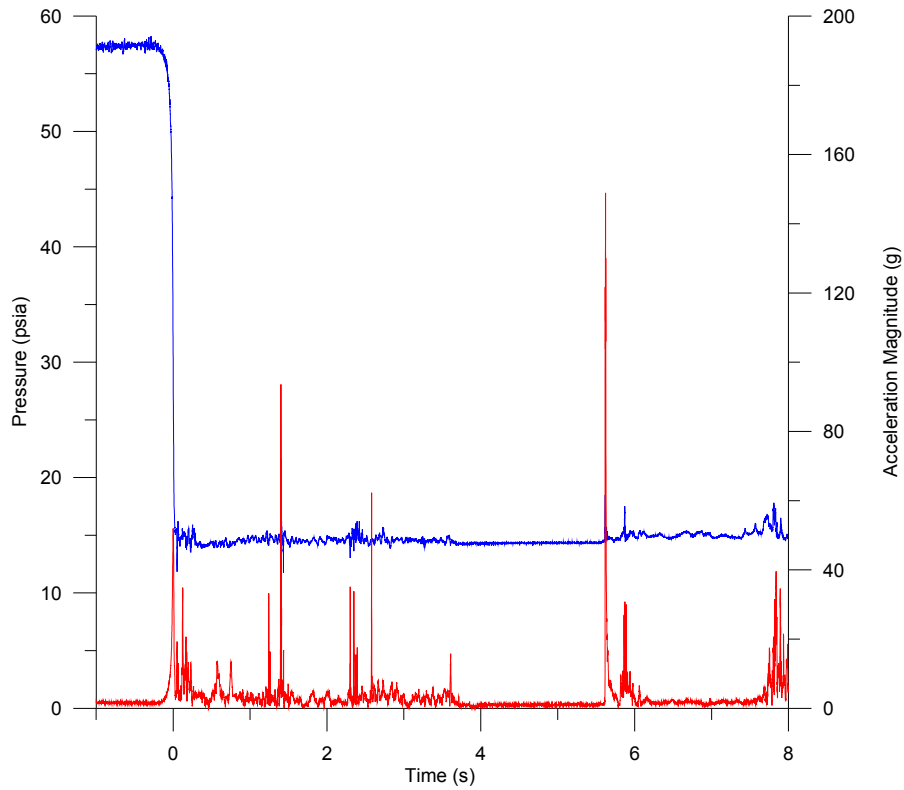
Detroit Dam RO 1 ft Opening, F109 (11)



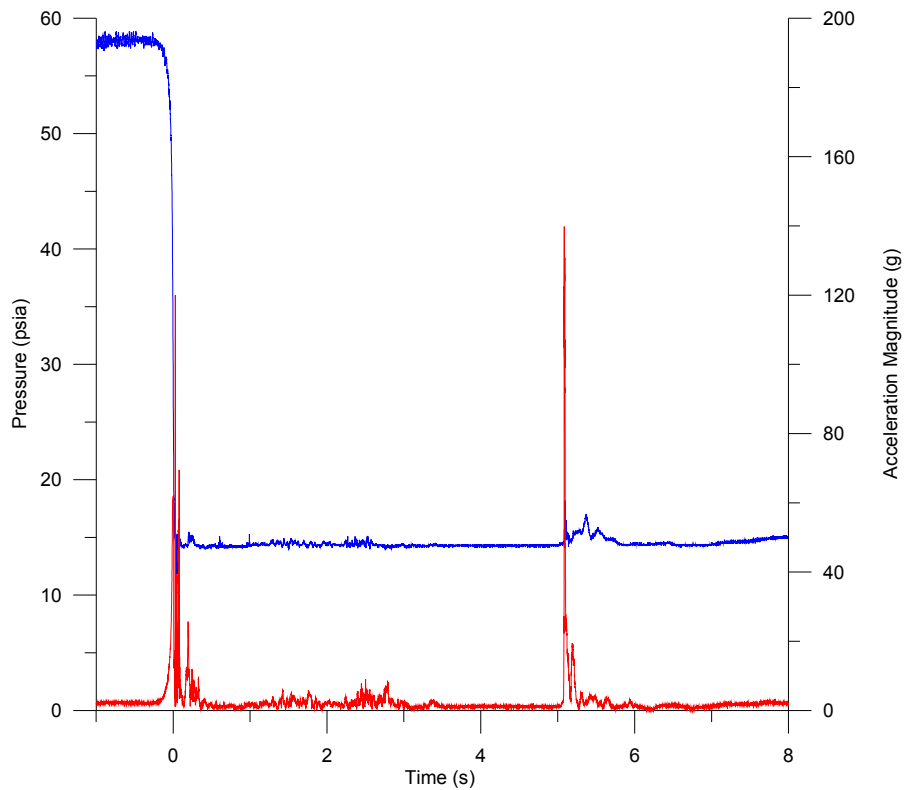
Detroit Dam RO 1 ft Opening, F930 (12)



Detroit Dam RO 1 ft Opening, F931 (13)

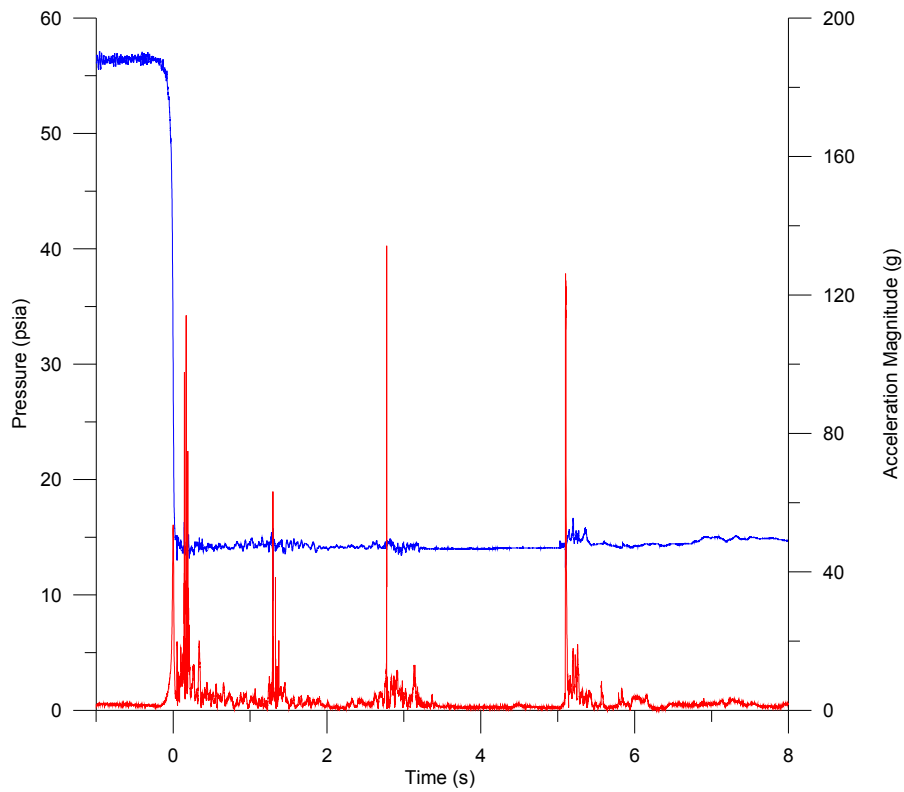


Detroit Dam RO 1 ft Opening, F121 (14)

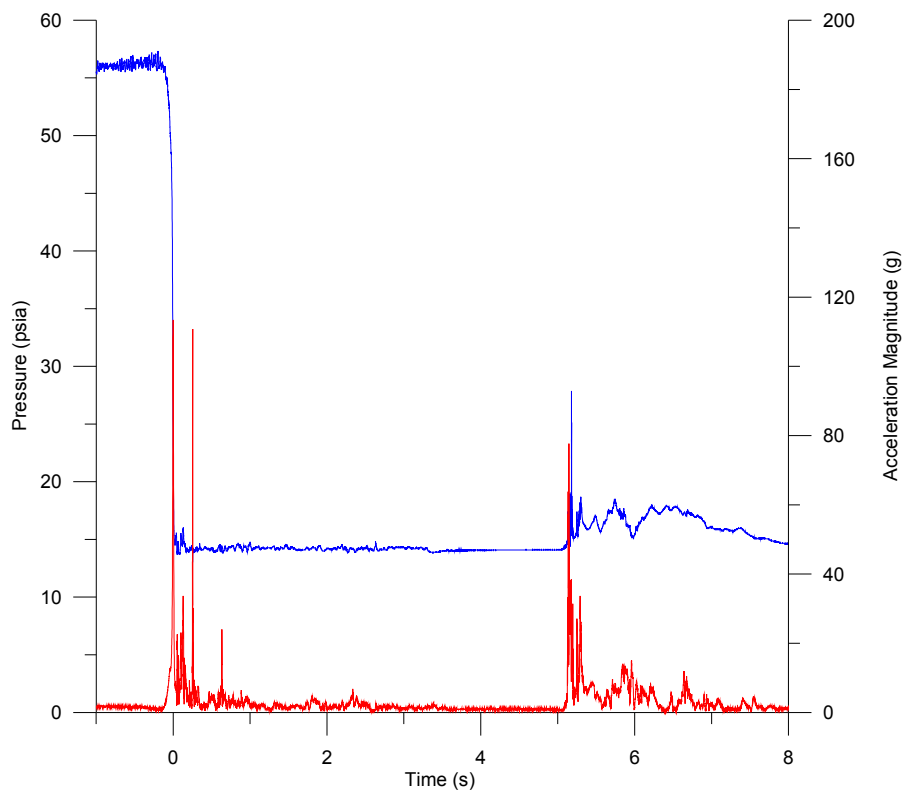


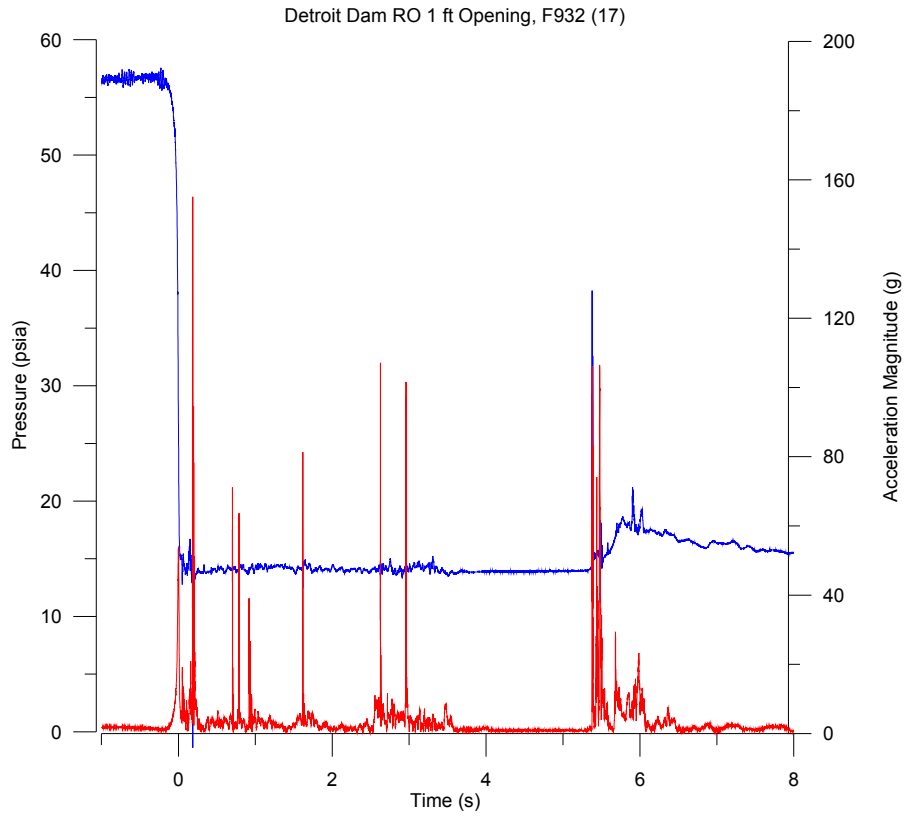


Detroit Dam RO 1 ft Opening, F913 (15)



Detroit Dam RO 1 ft Opening, F914 (16)

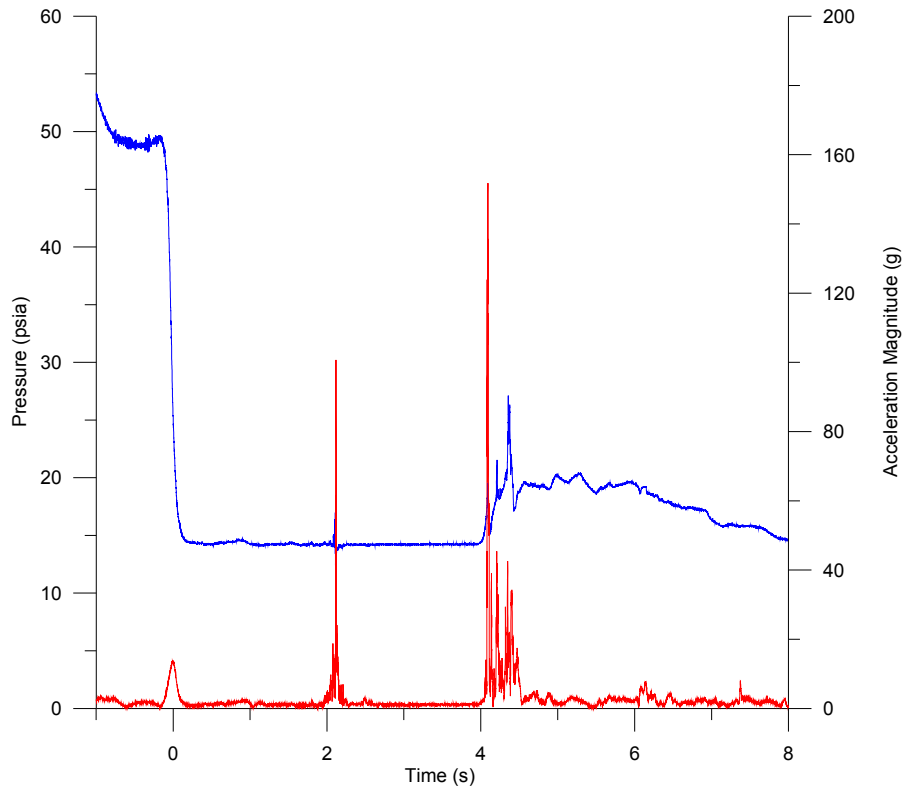




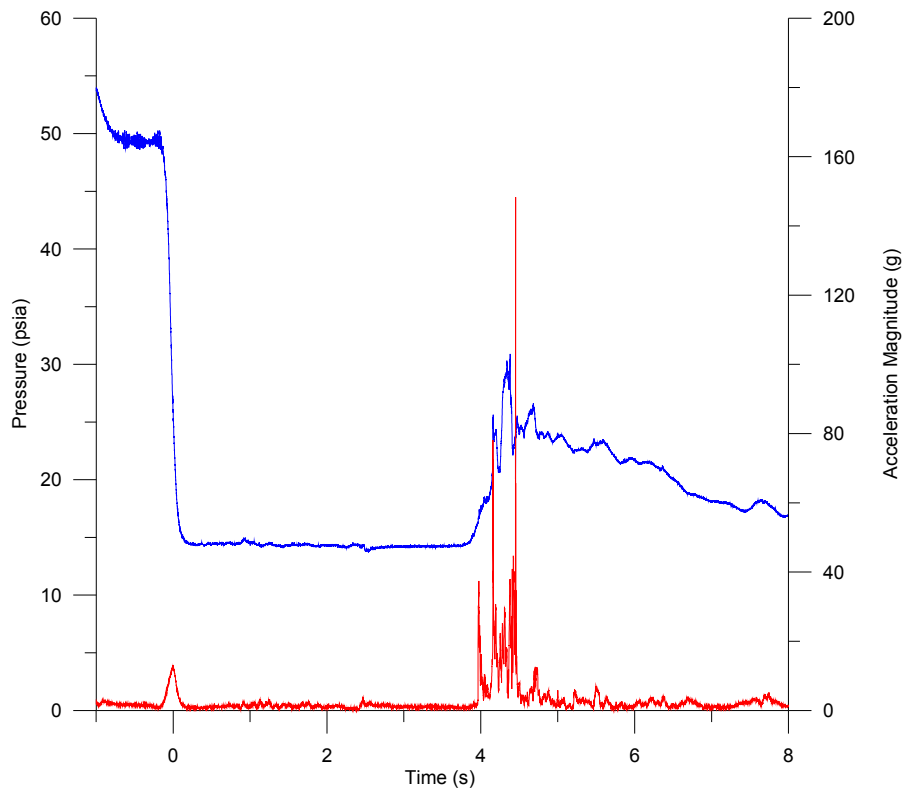
## **Detroit Dam Regulating Outlet**

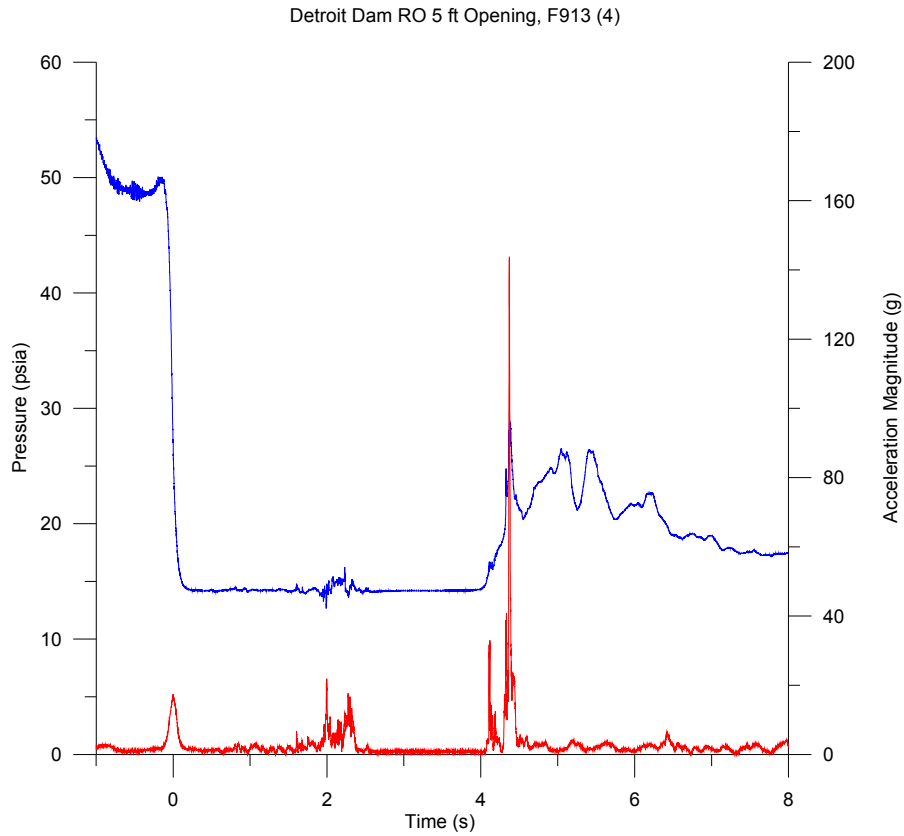
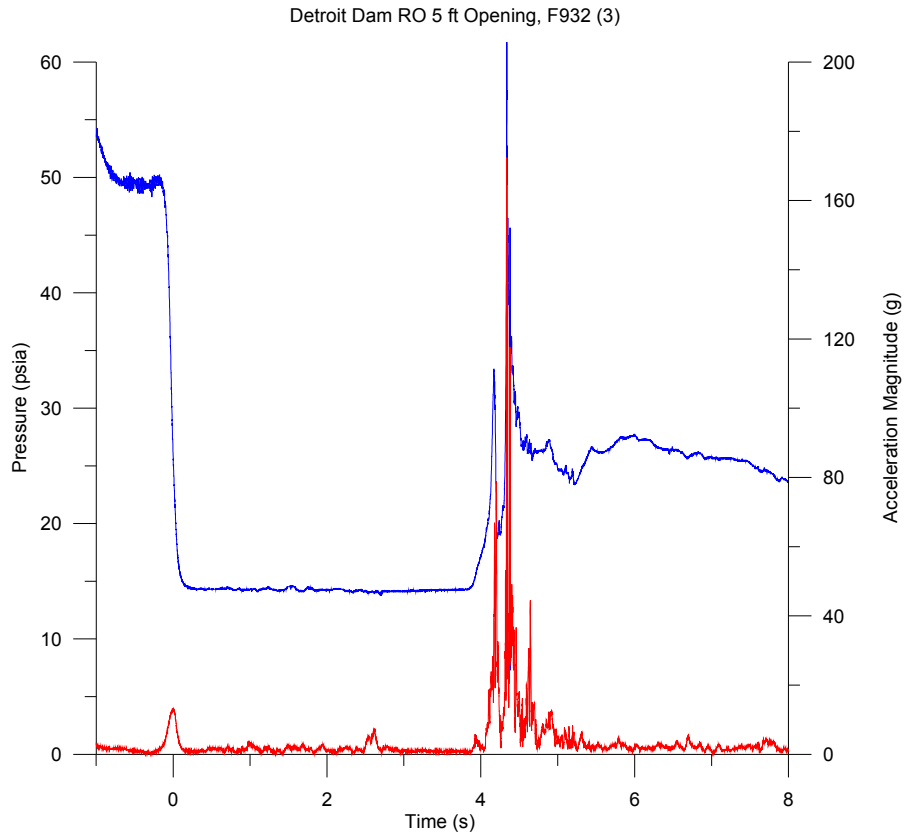
### **5-ft Gate Opening**

Detroit Dam RO 5 ft Opening, F931 (1)

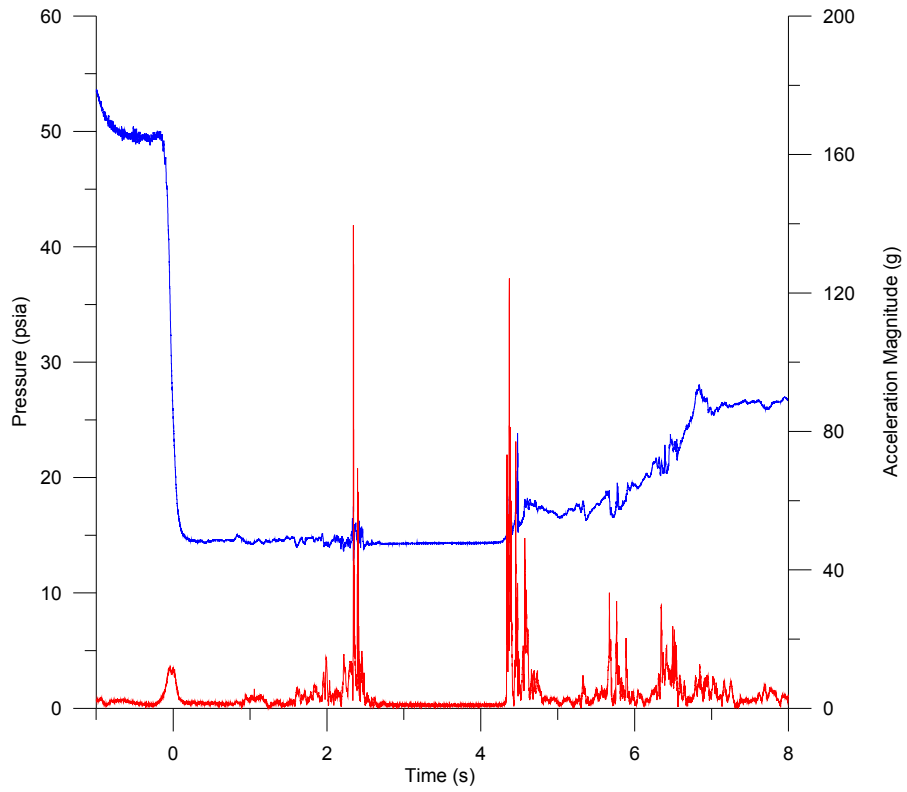


Detroit Dam RO 5 ft Opening, F924 (2)

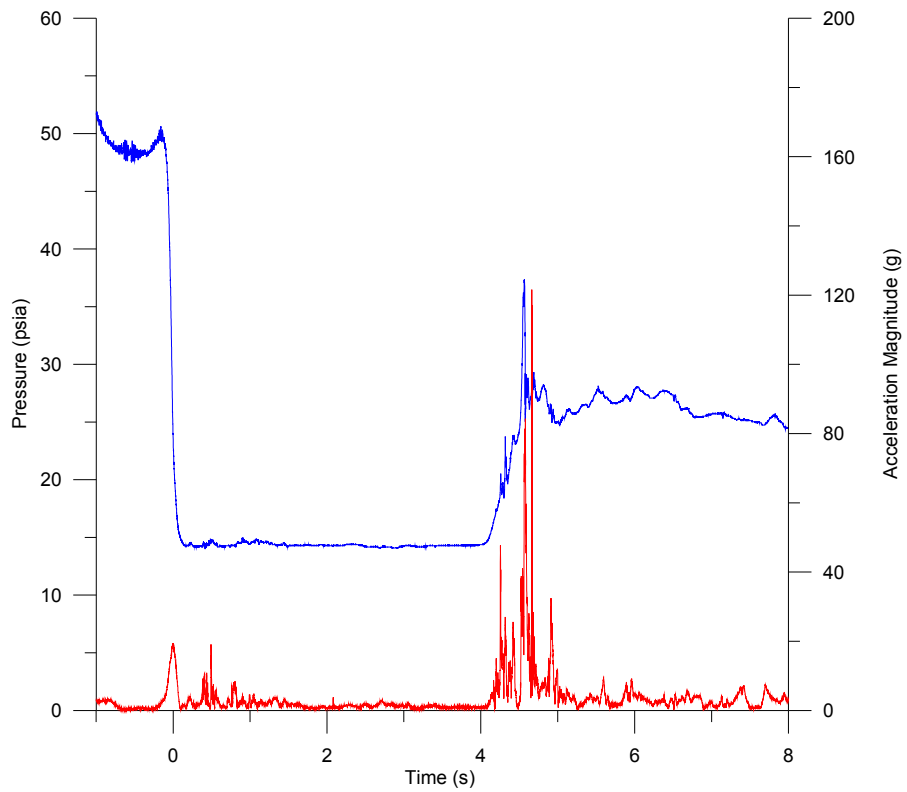




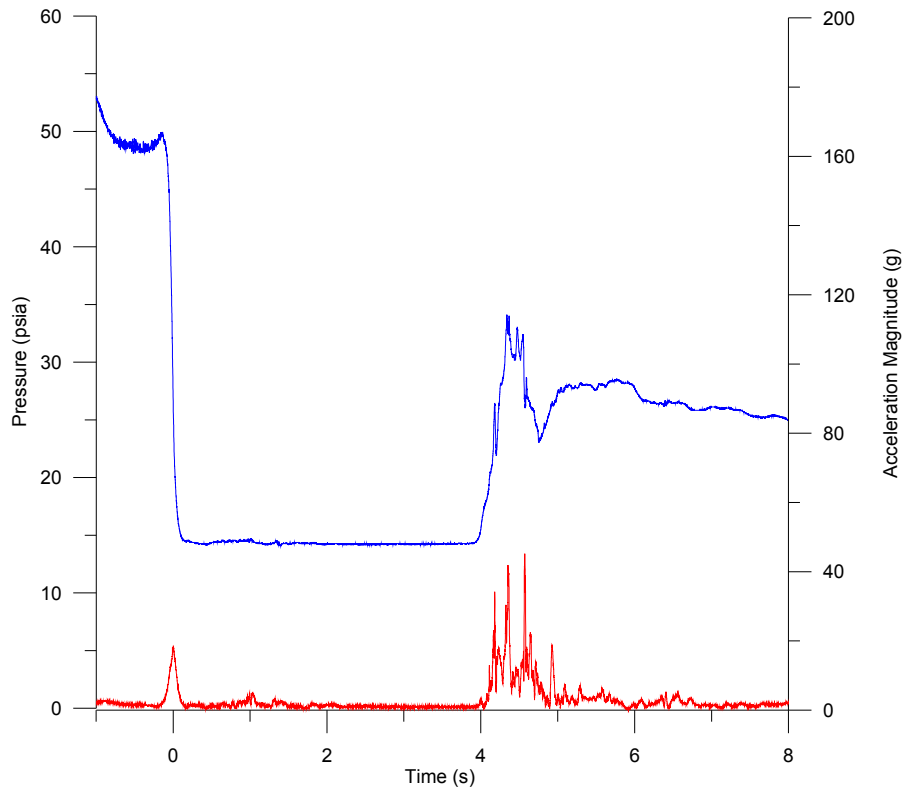
Detroit Dam RO 5 ft Opening, F908 (5)



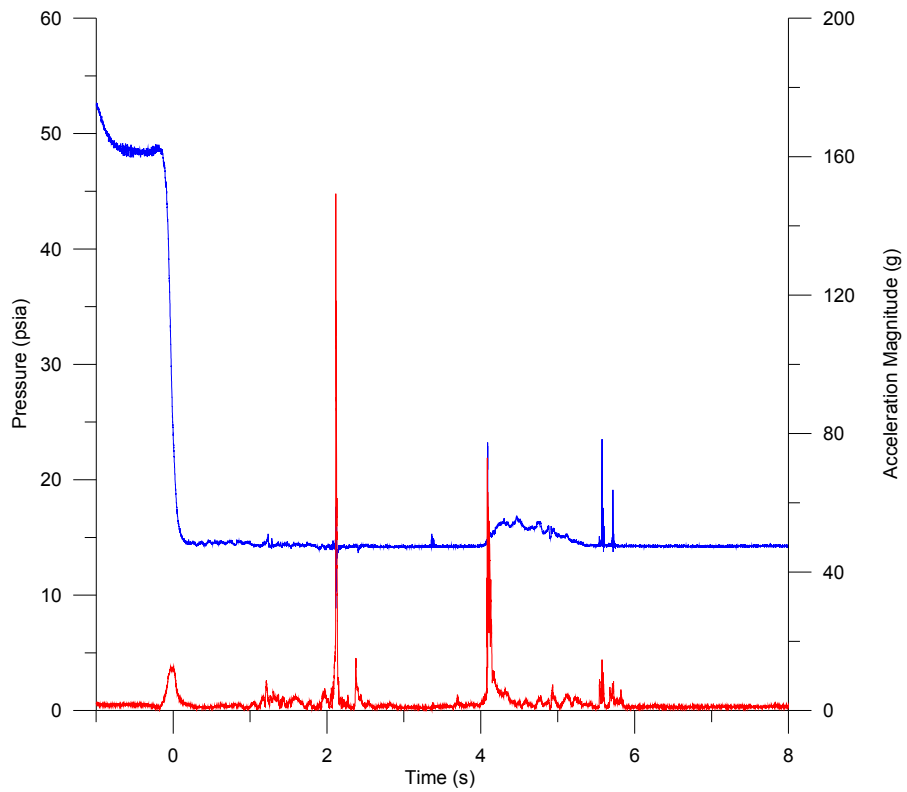
Detroit Dam RO 5 ft Opening, F914 (6)



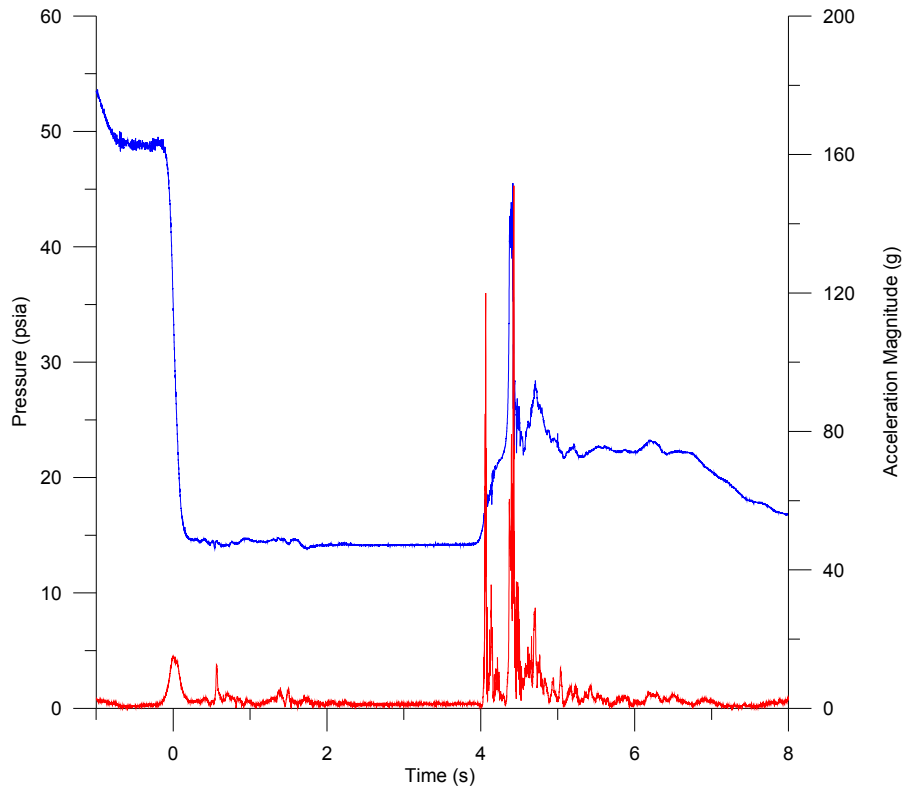
Detroit Dam RO 5 ft Opening, F923 (7)



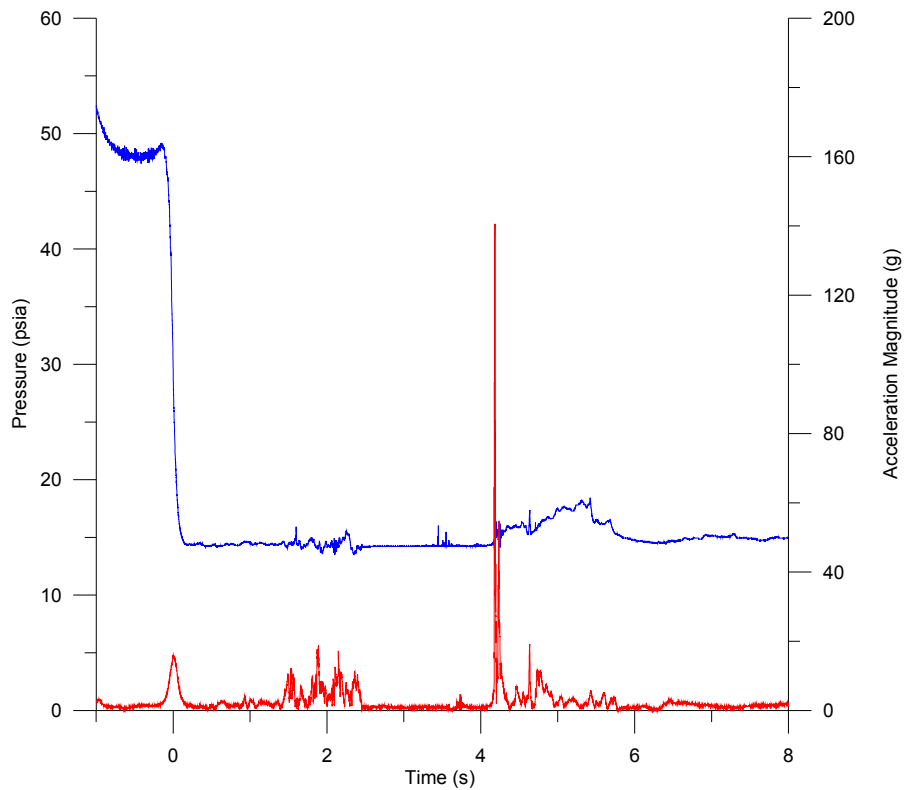
Detroit Dam RO 5 ft Opening, F924 (8)



Detroit Dam RO 5 ft Opening, F103 (9)

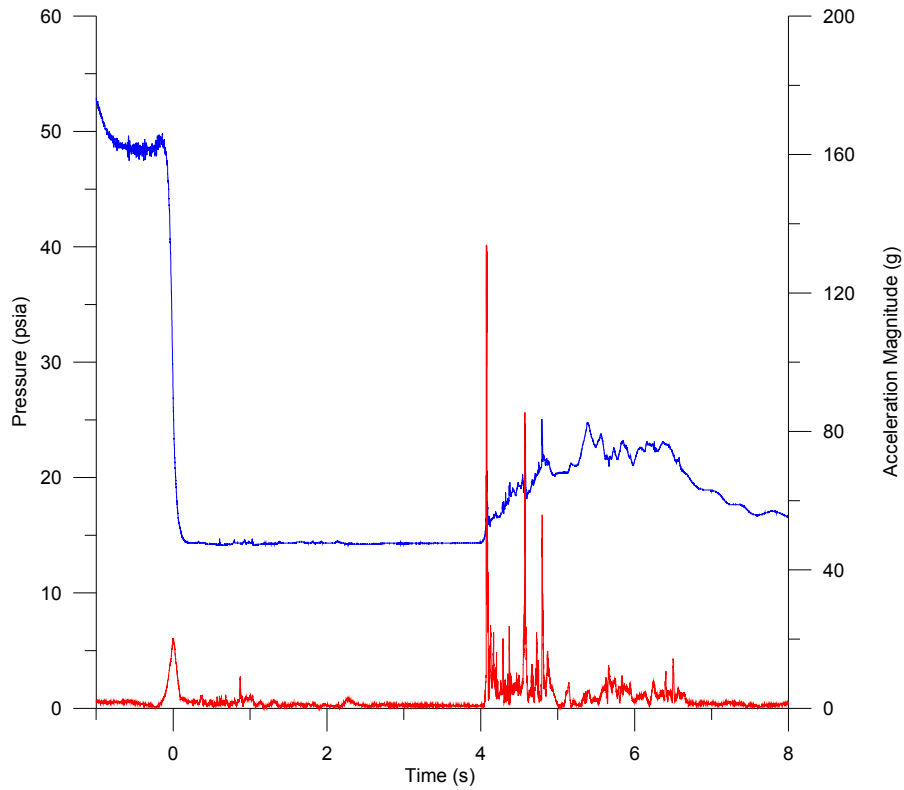


Detroit Dam RO 5 ft Opening, F913 (10)

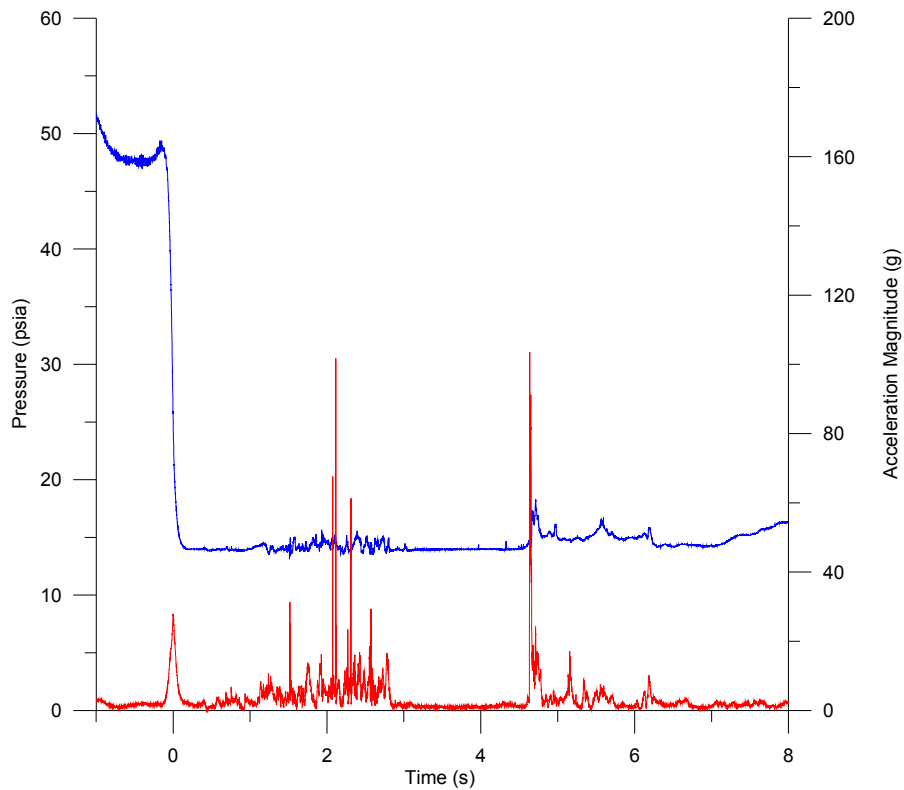




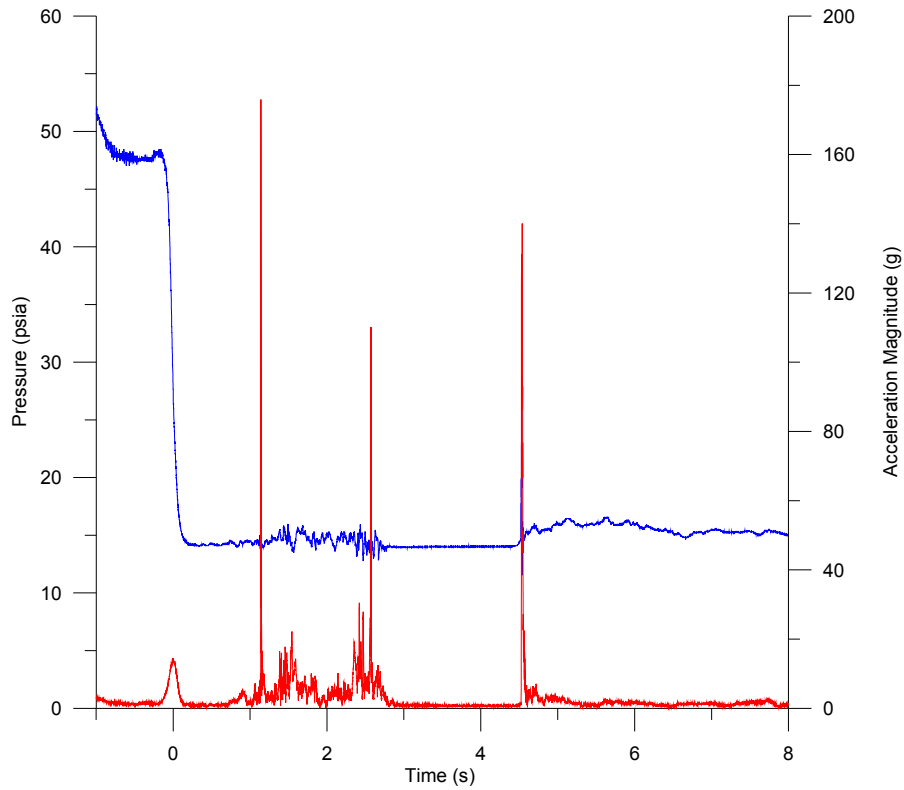
Detroit Dam RO 5 ft Opening, F914 (11)



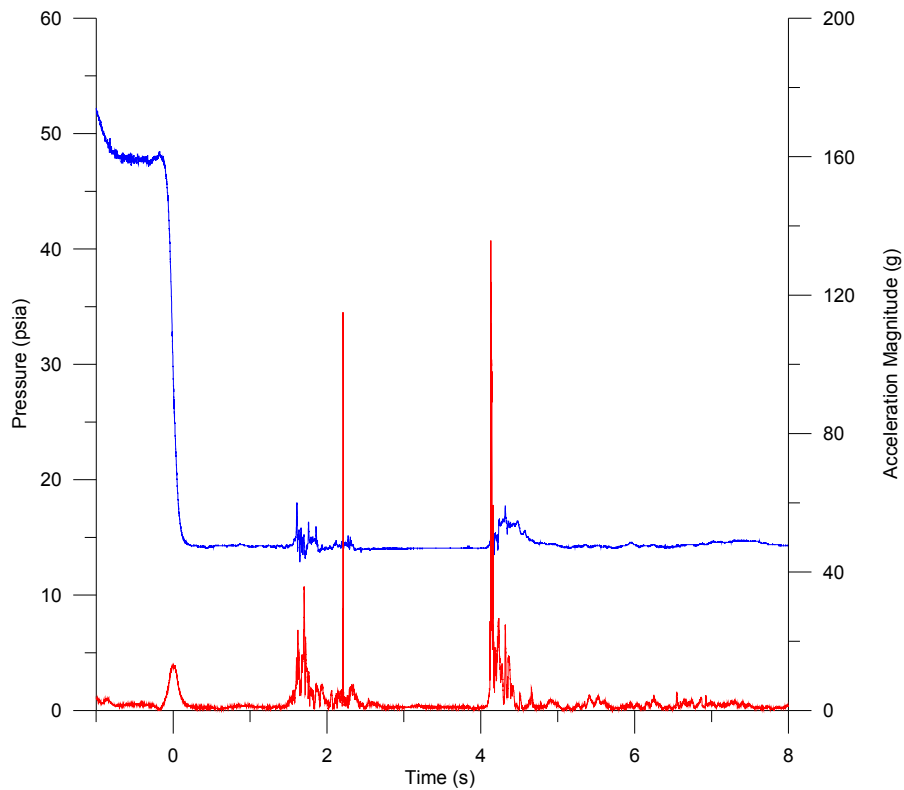
Detroit Dam RO 5 ft Opening, F103 (12)



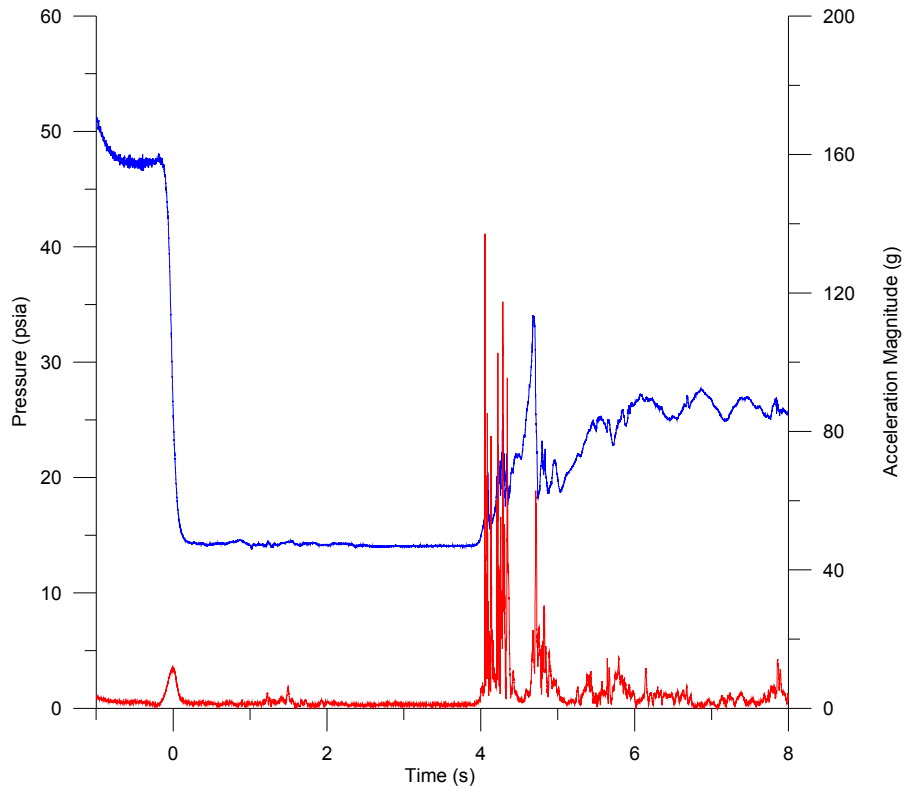
Detroit Dam RO 5 ft Opening, F908 (13)



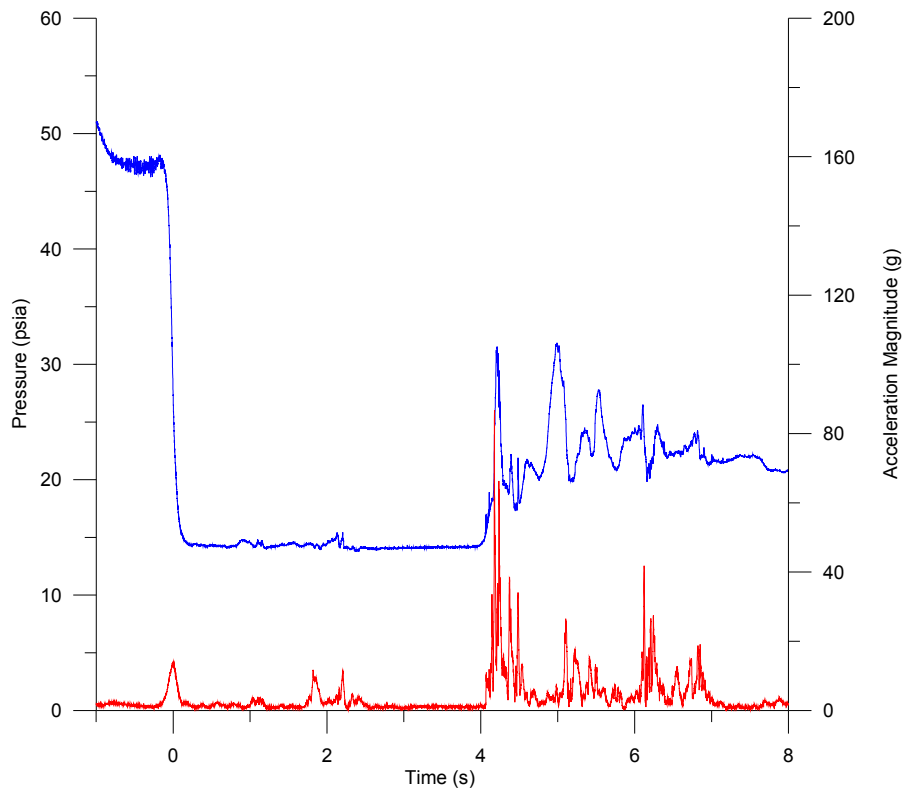
Detroit Dam RO 5 ft Opening, F923 (14)



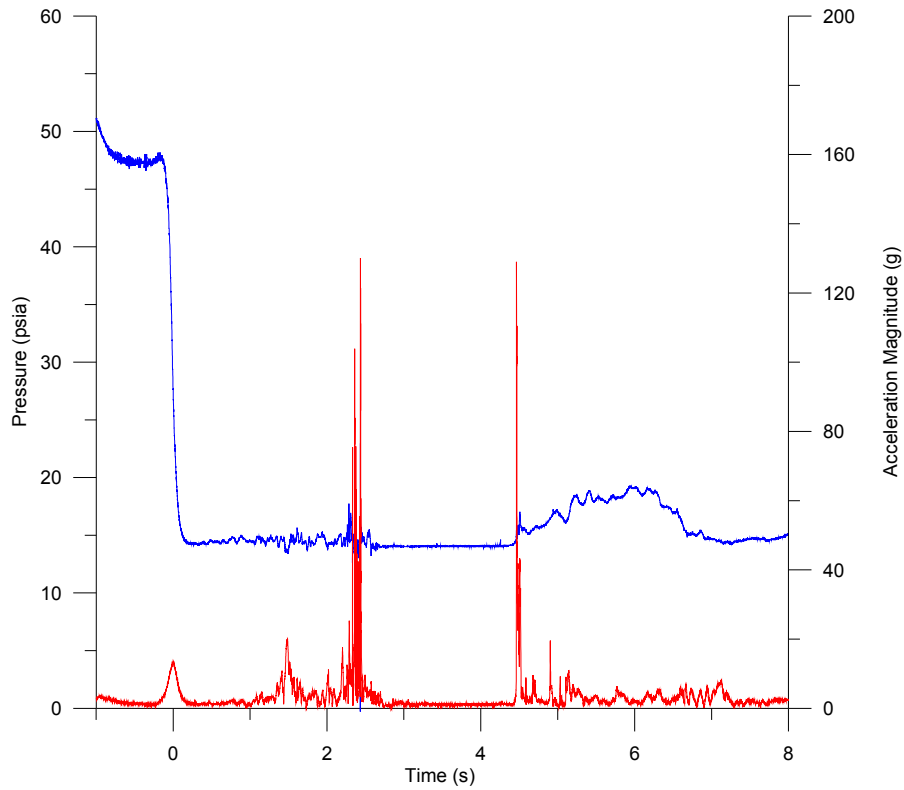
Detroit Dam RO 5 ft Opening, F930 (15)



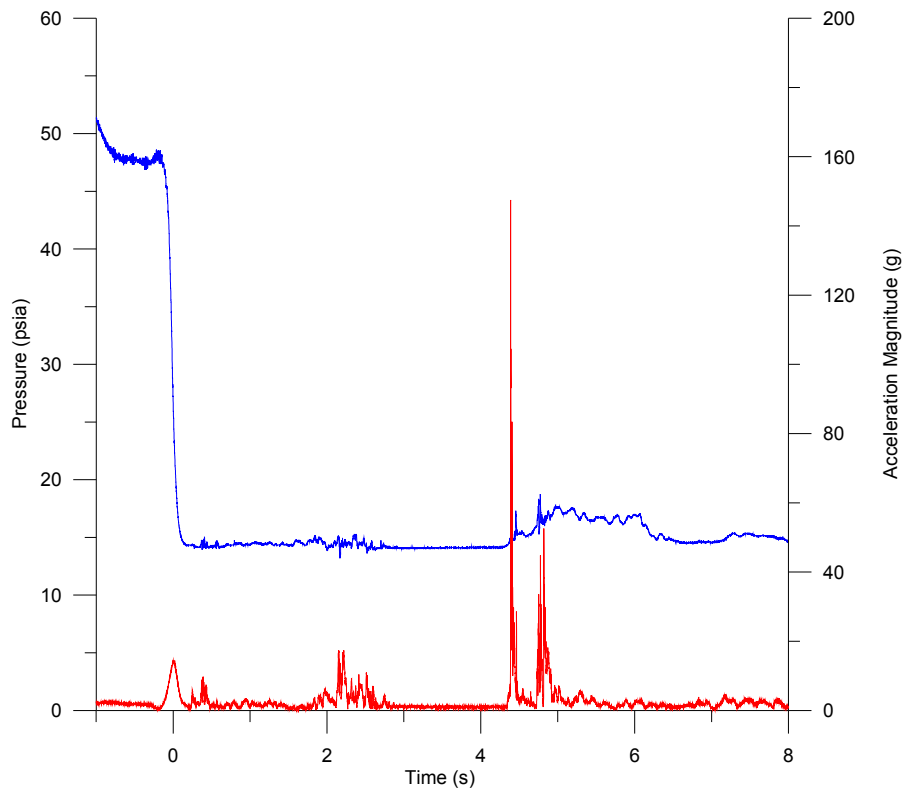
Detroit Dam RO 5 ft Opening, F931 (16)

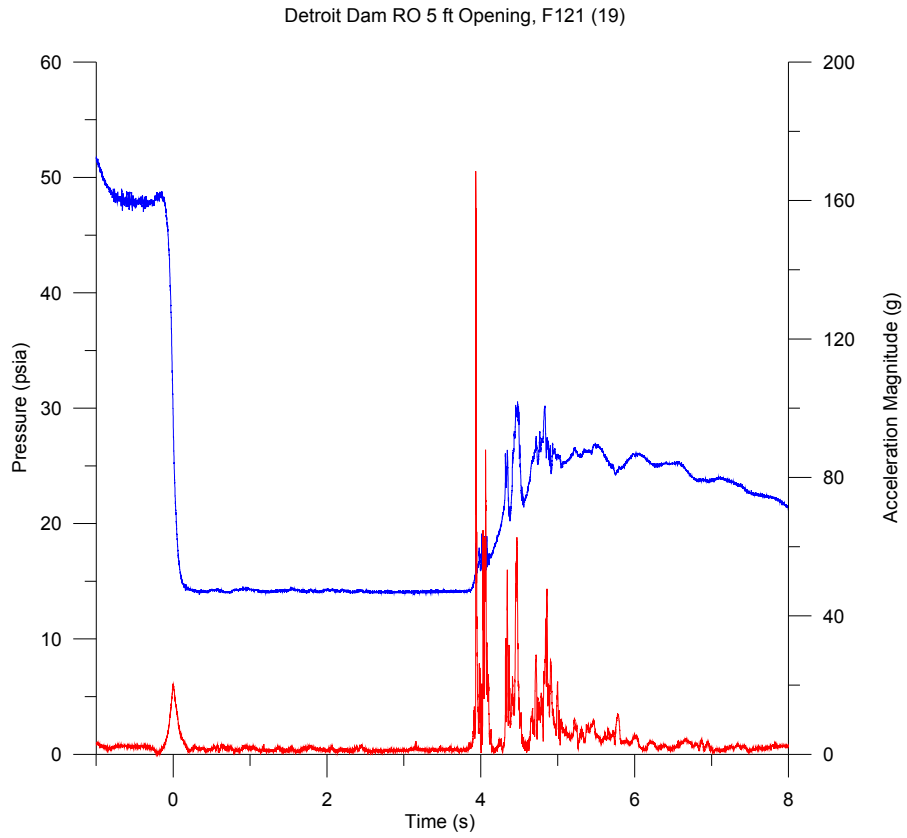


Detroit Dam RO 5 ft Opening, F109 (17)

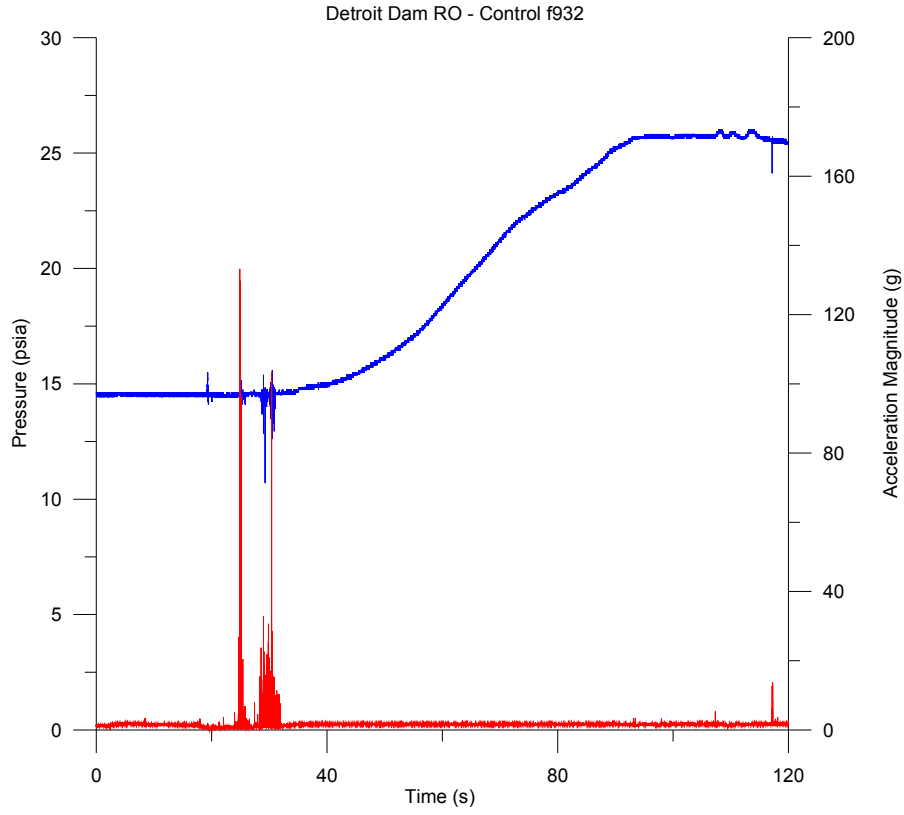


Detroit Dam RO 5 ft Opening, F908 (18)





# **Detroit Dam Regulating Outlet Control**

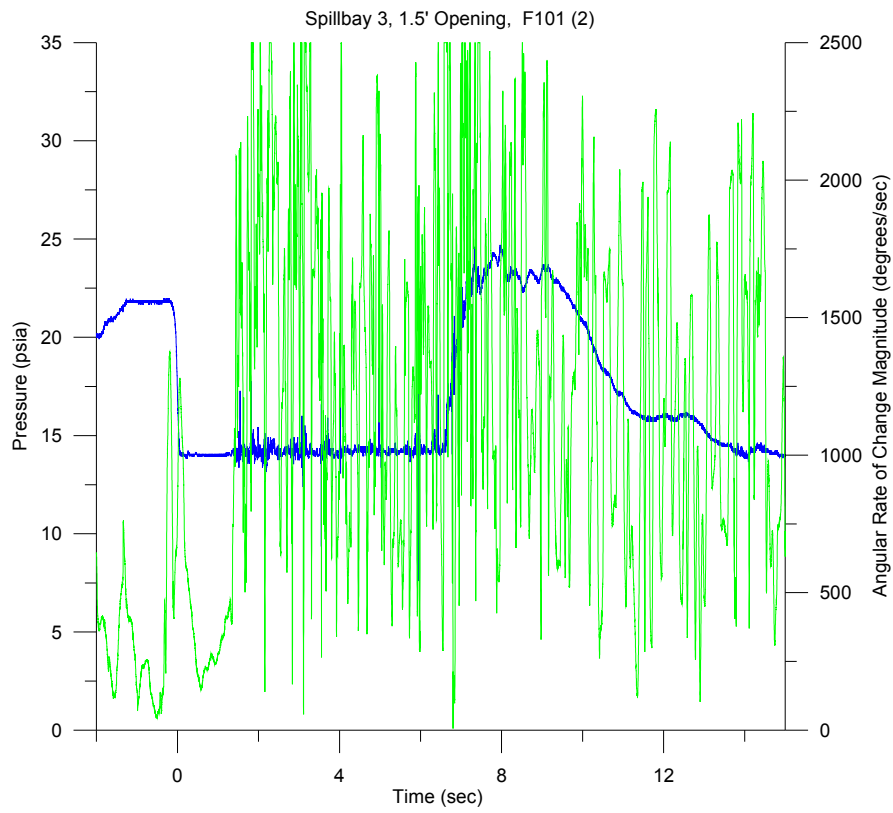
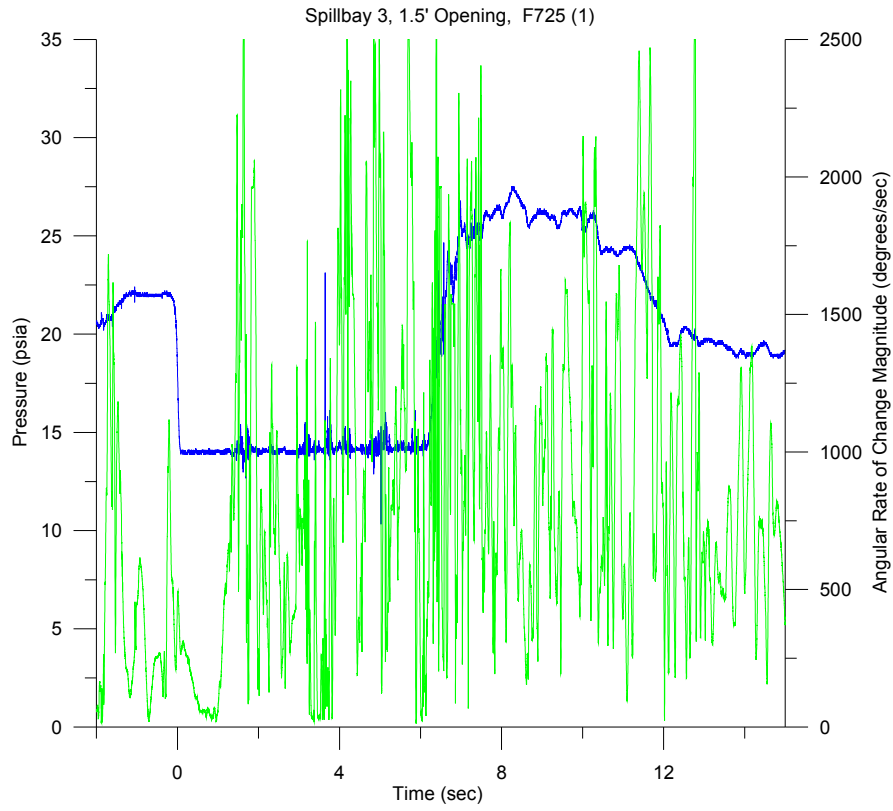


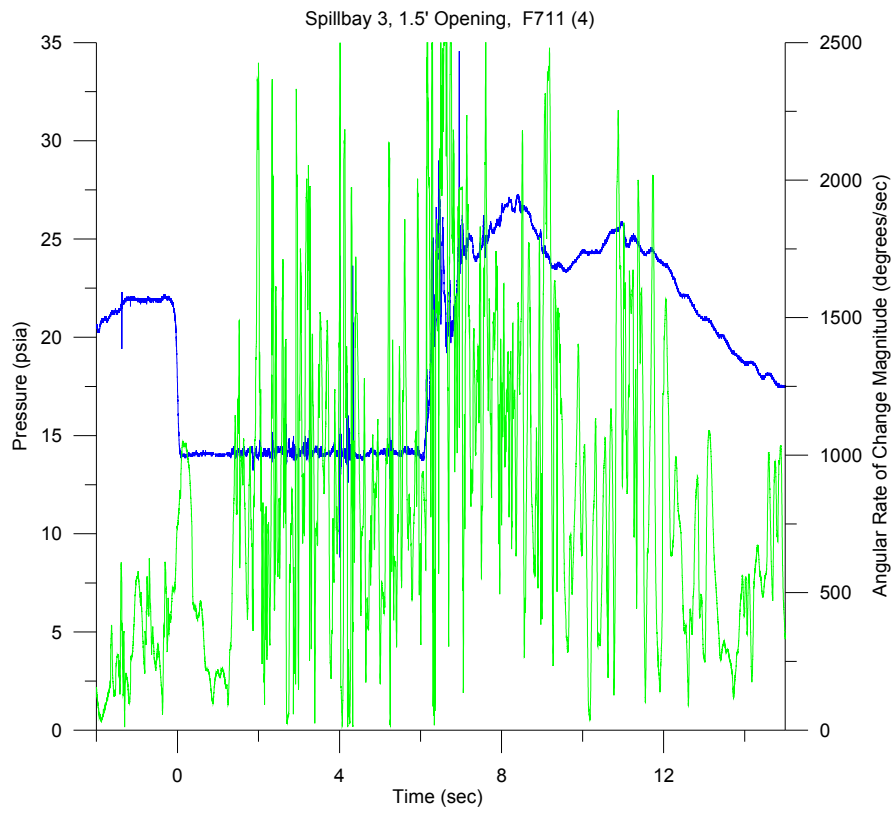
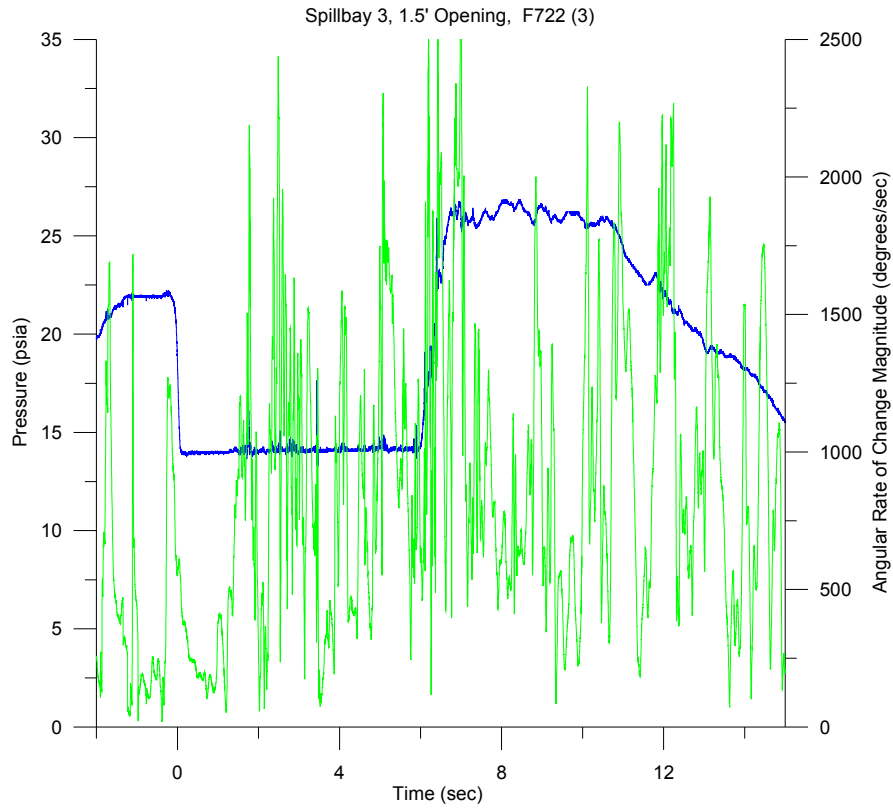
## **Appendix D**

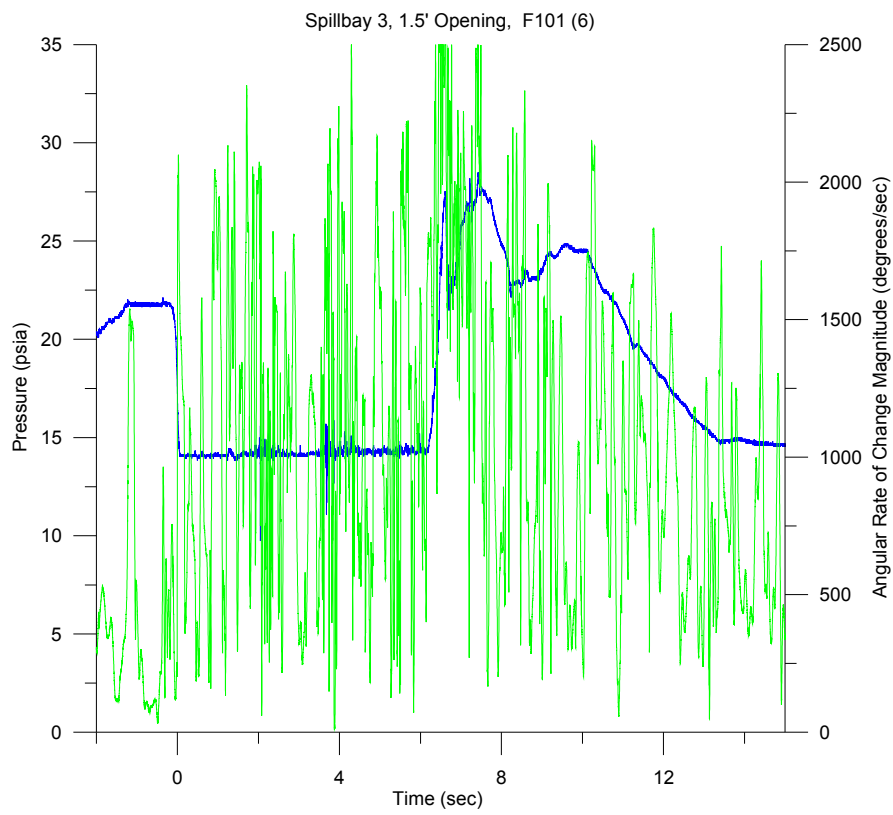
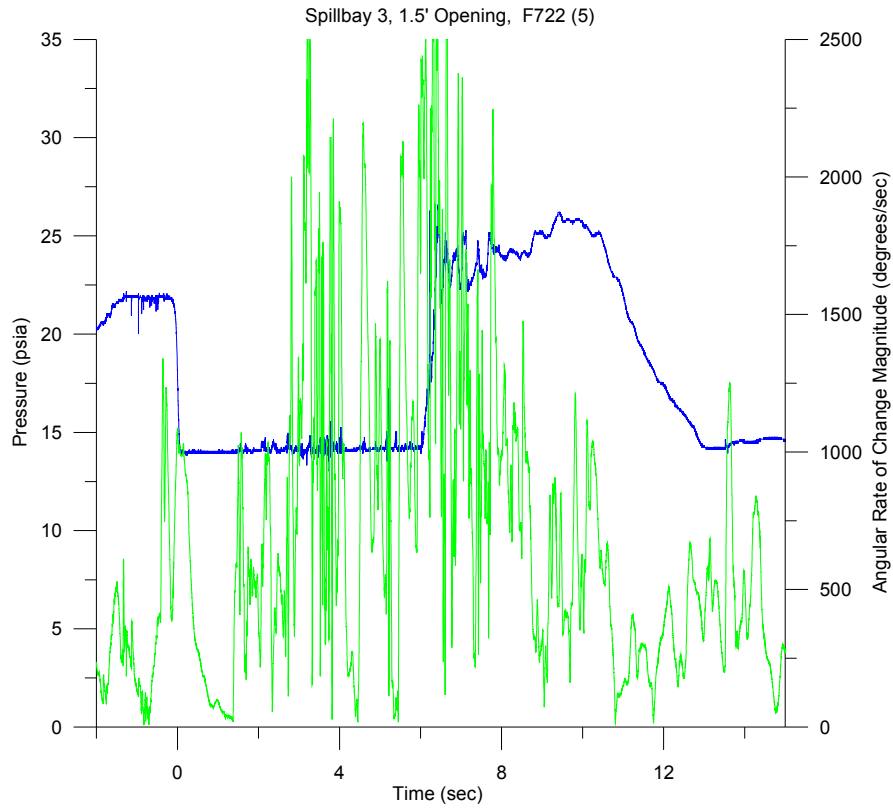
### **Pressure and Angular Rate of Change Time Histories of Each Sensor Fish Release**

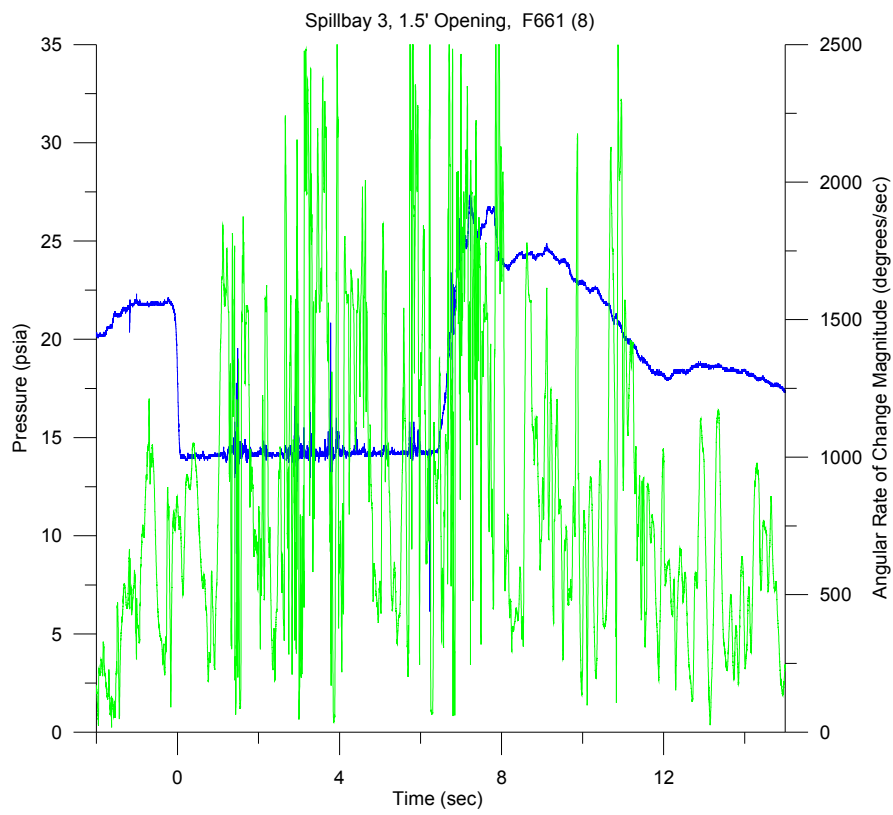
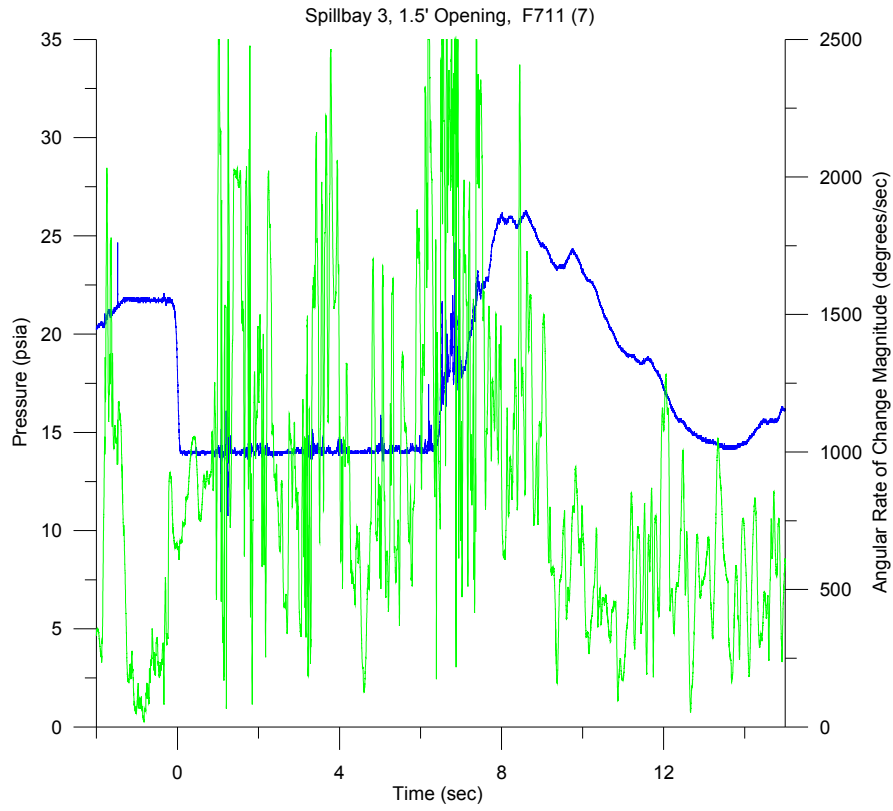


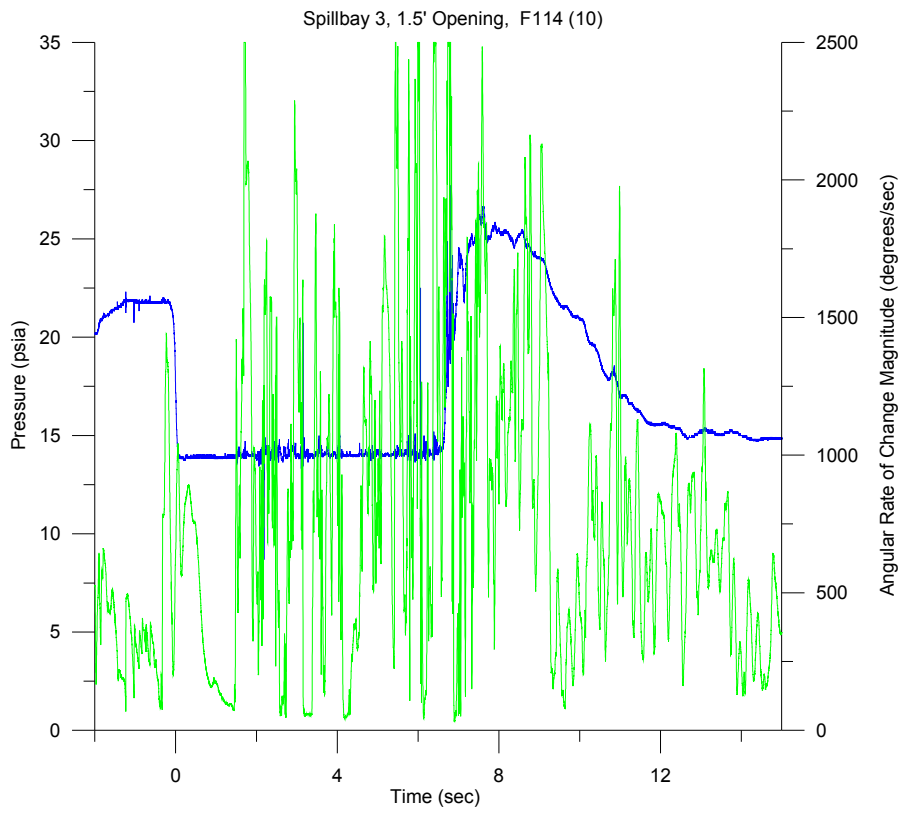
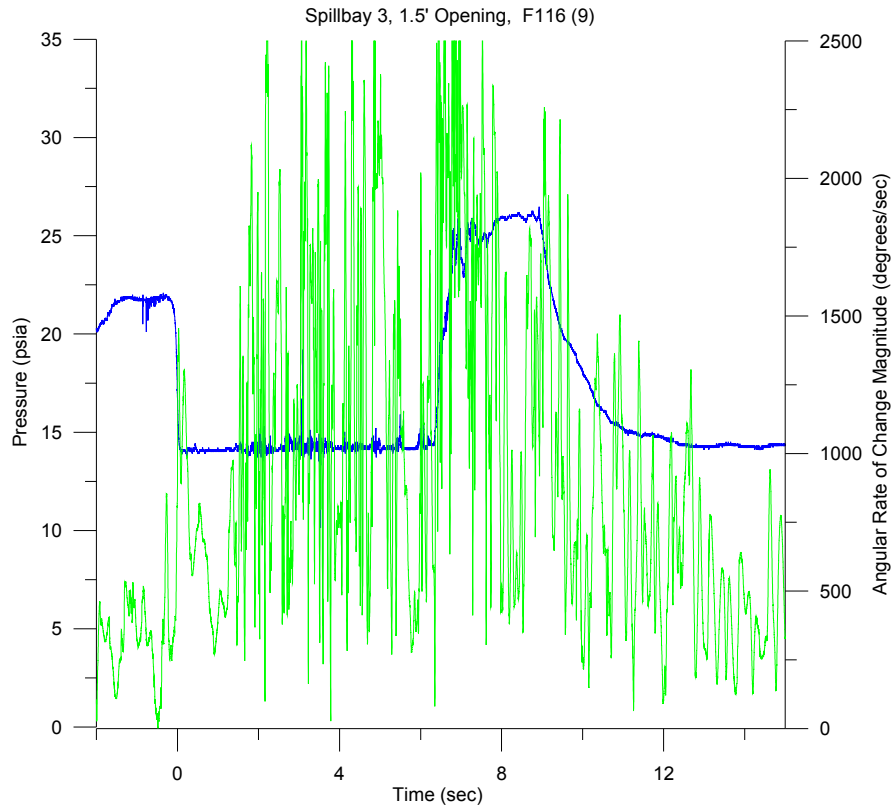
**Detroit Dam Spillway Evaluation**  
**Spillbay 3, 1.5-ft Gate Opening**

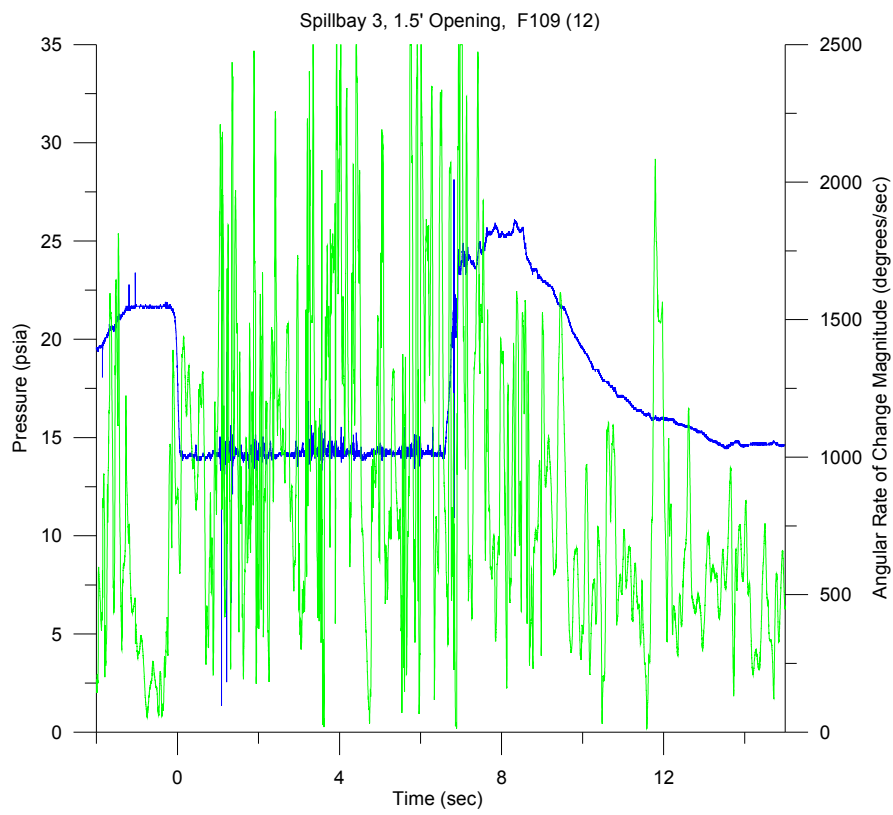
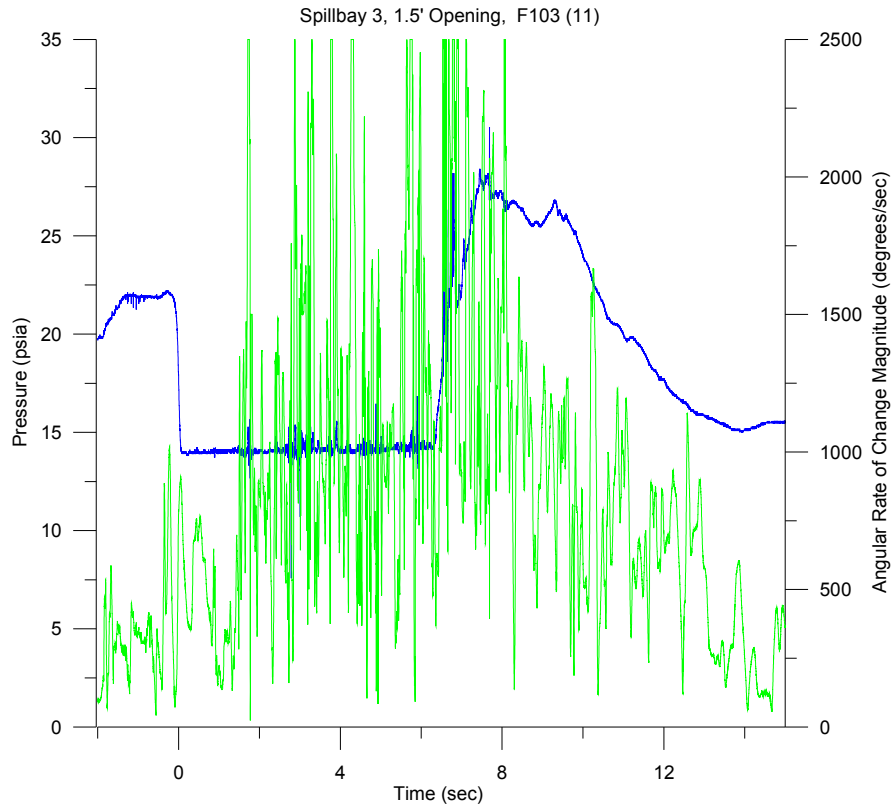


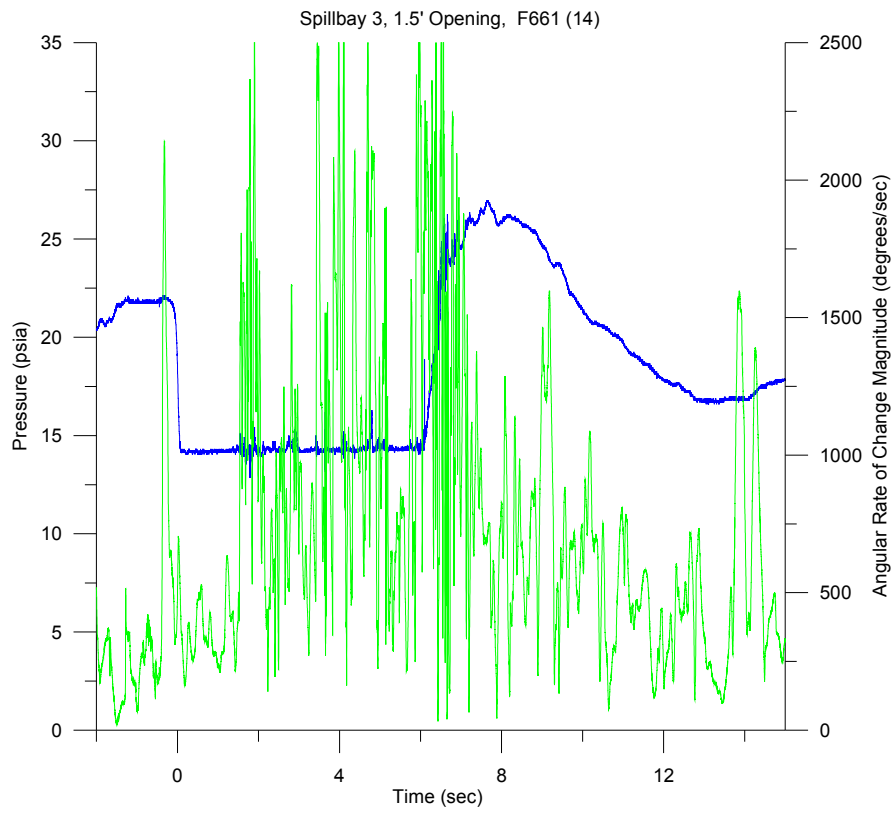
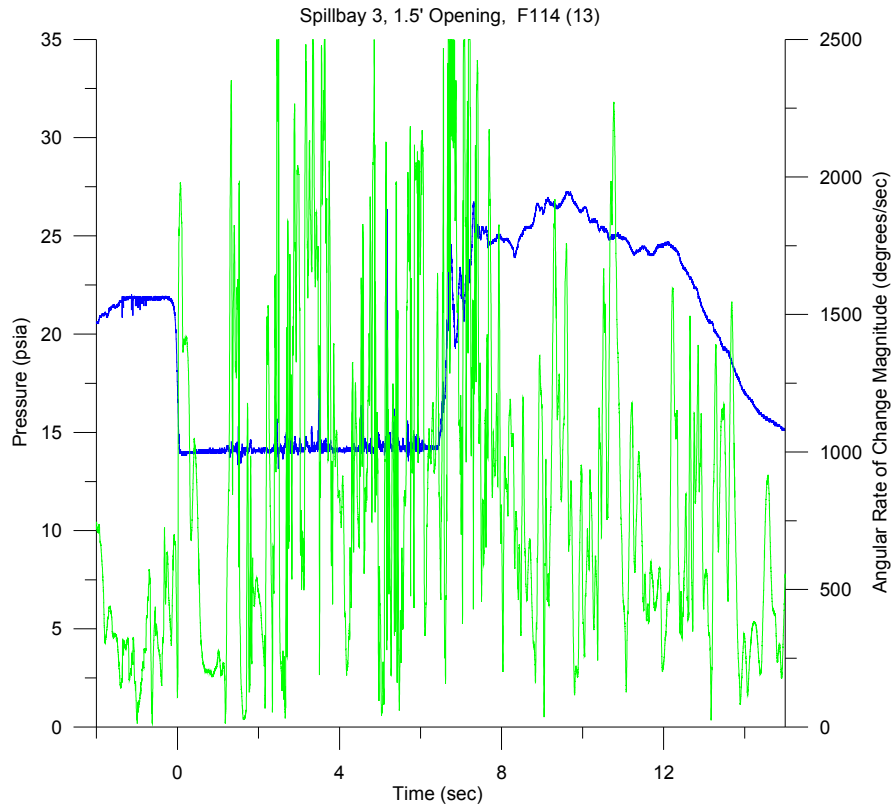




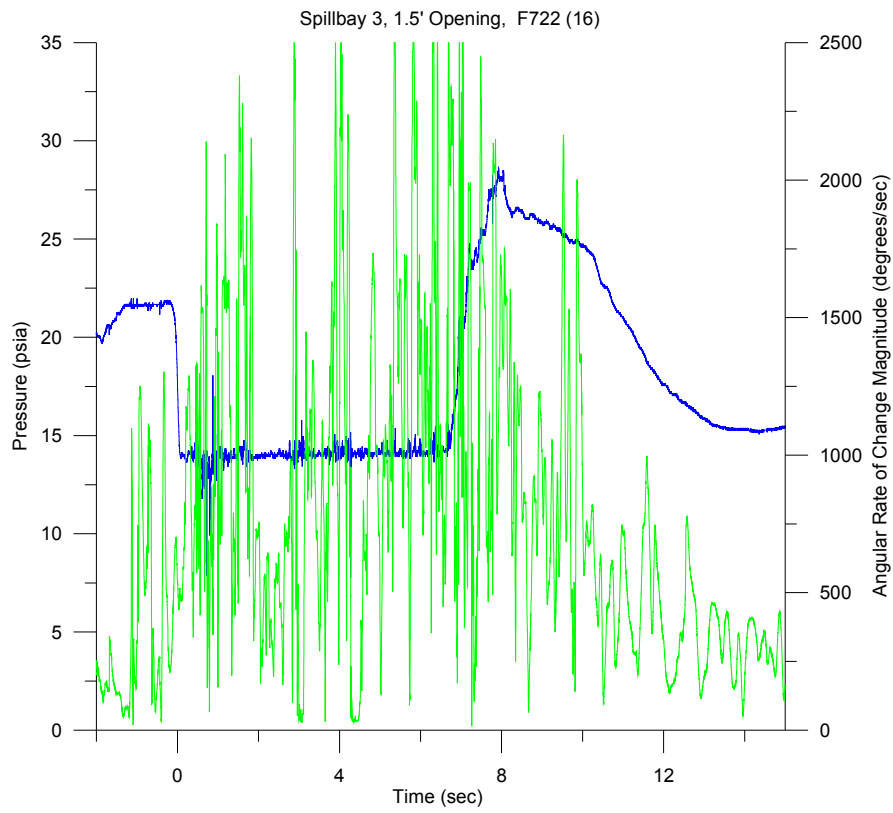
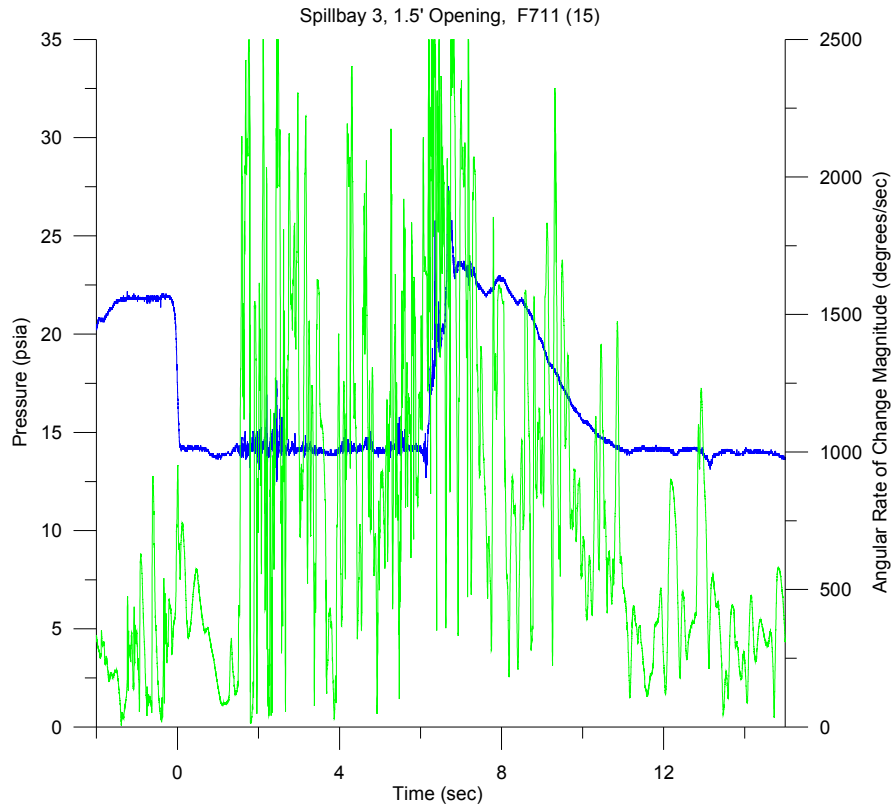


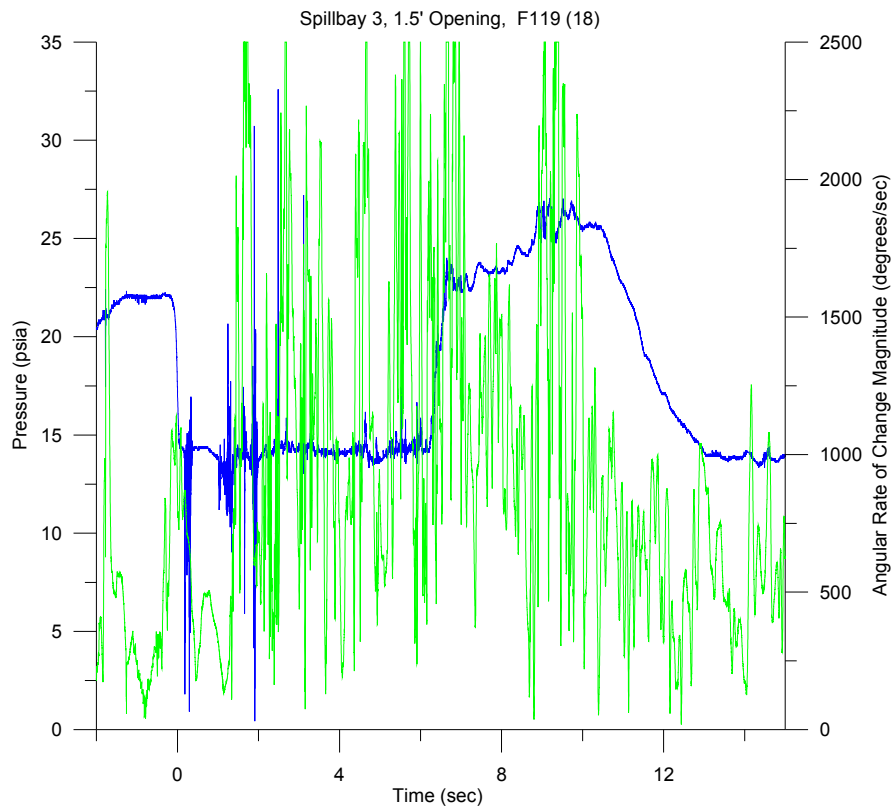
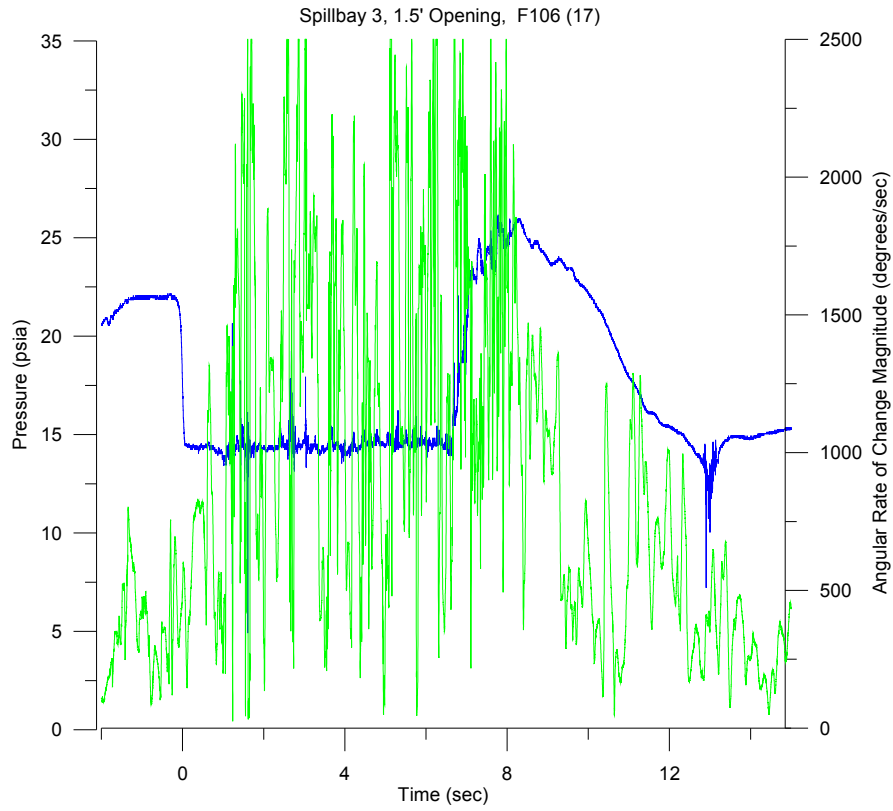


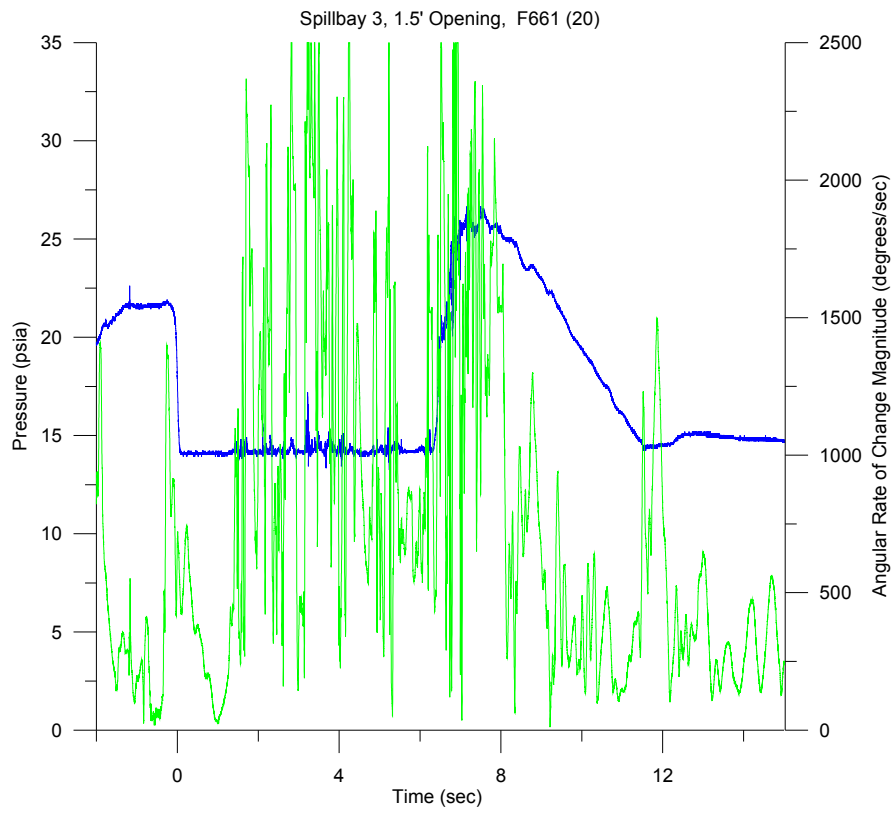
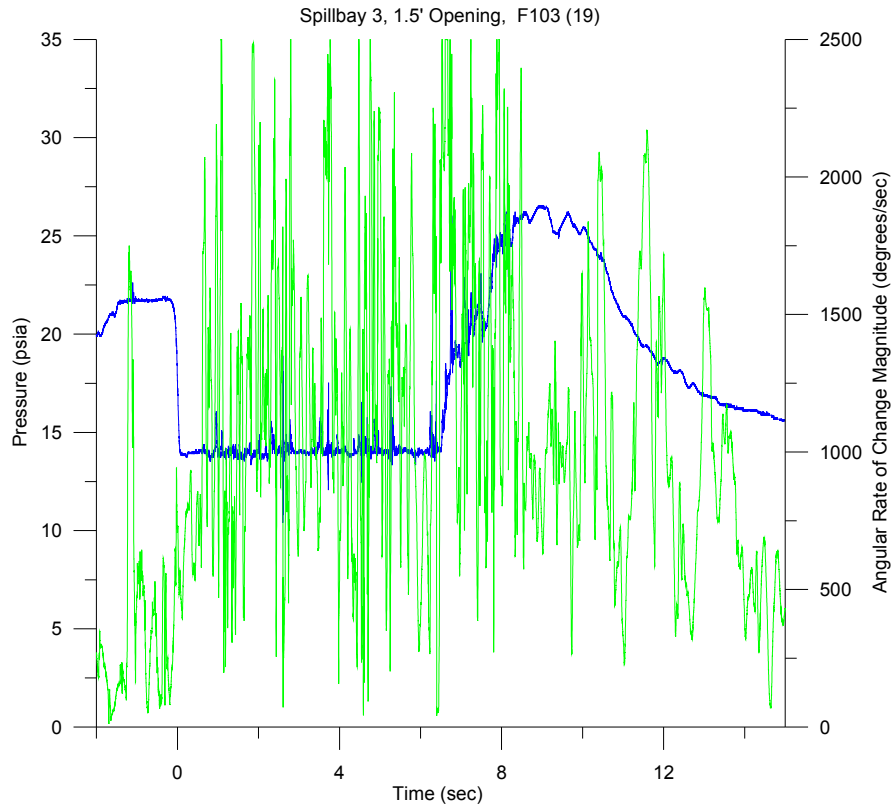


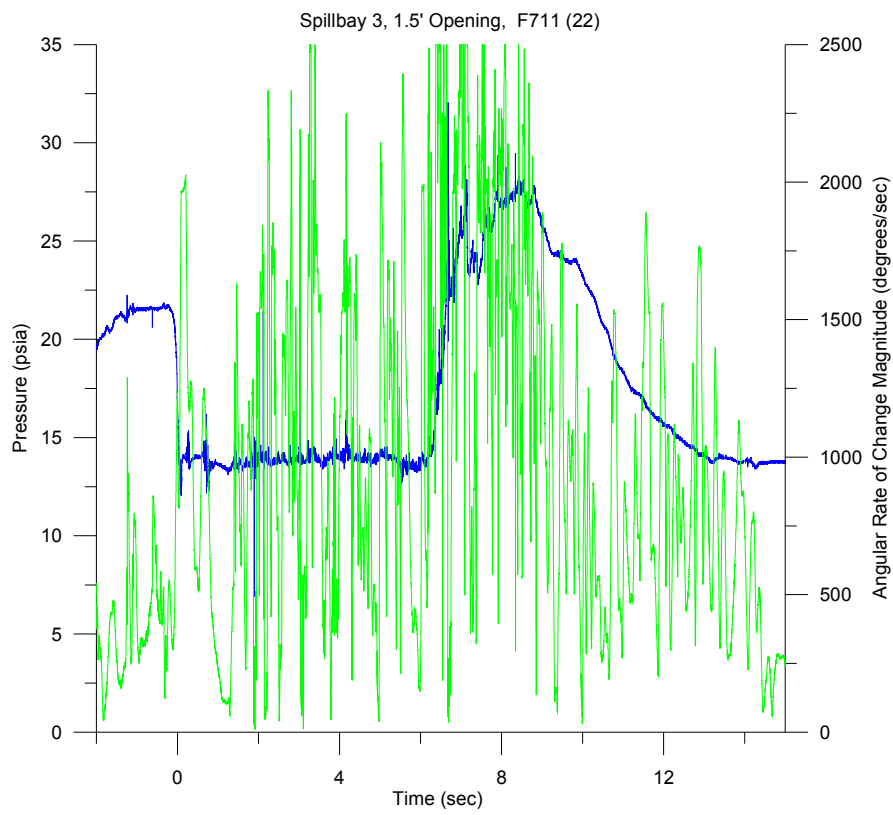
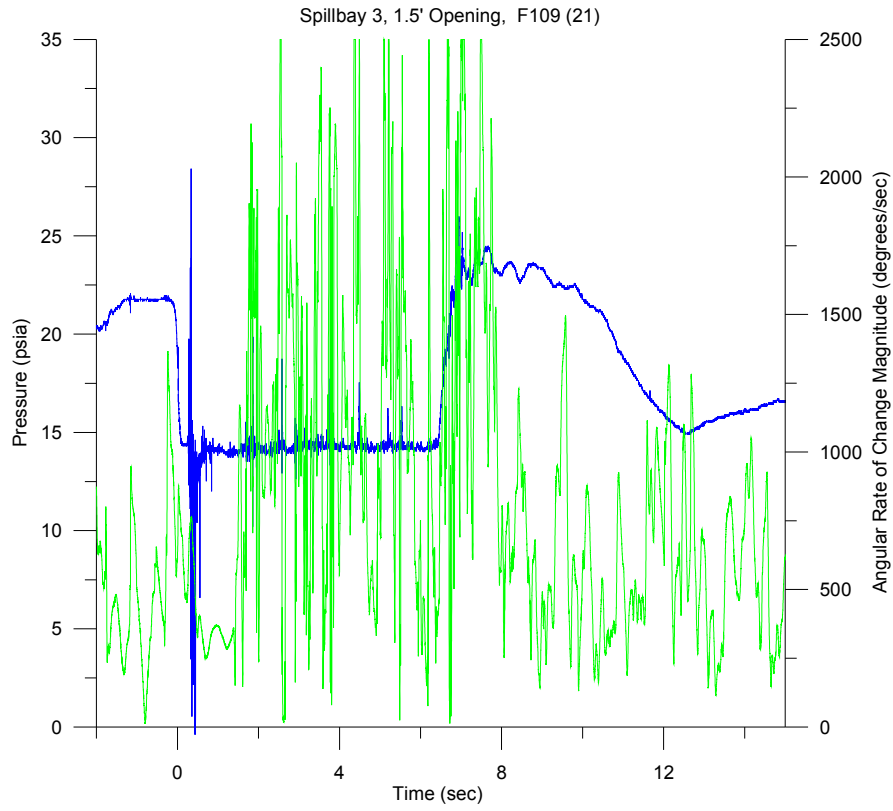


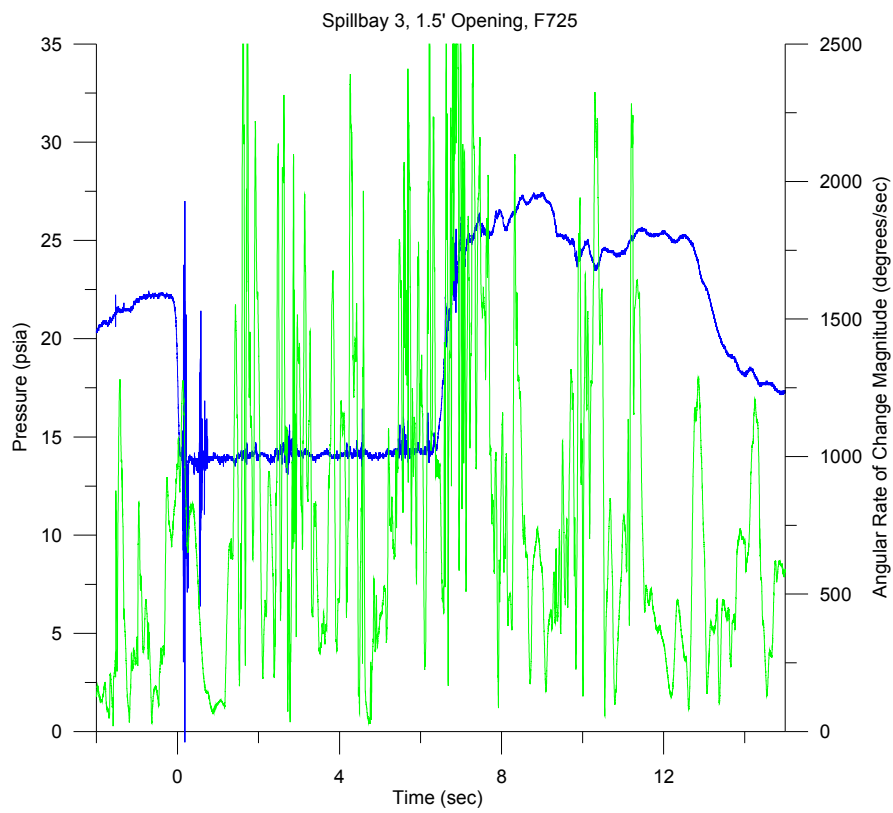
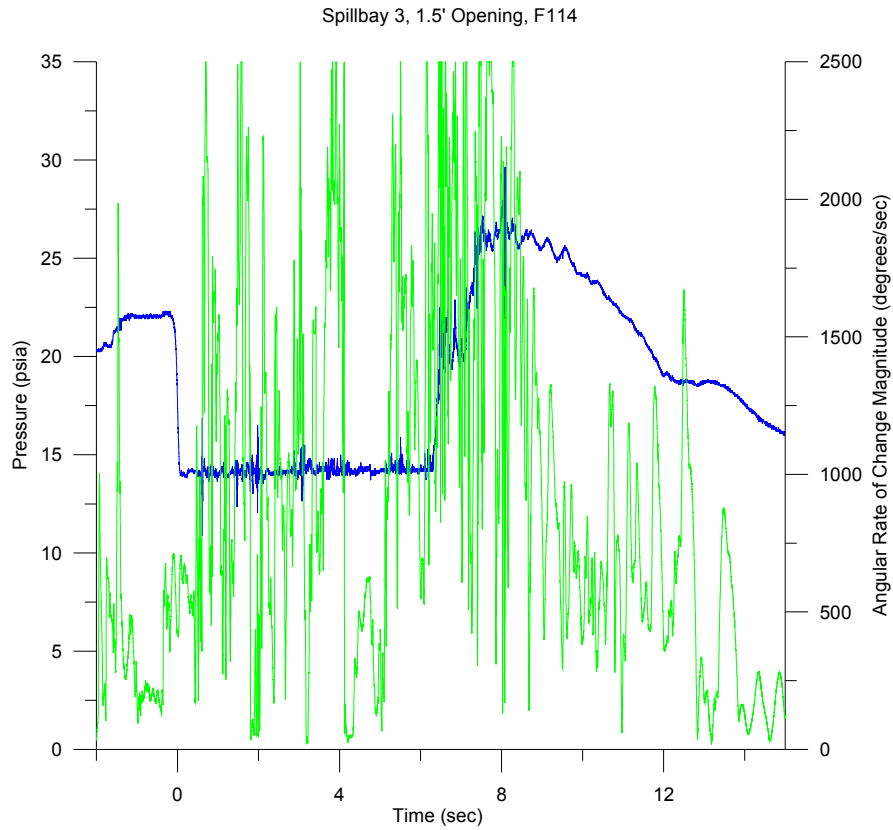






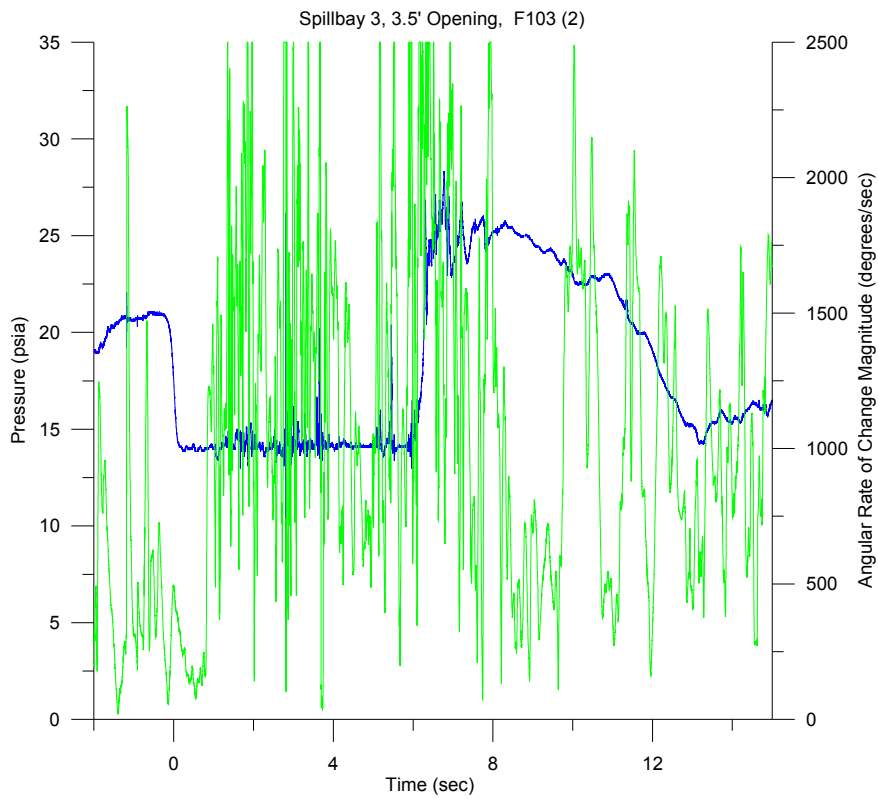
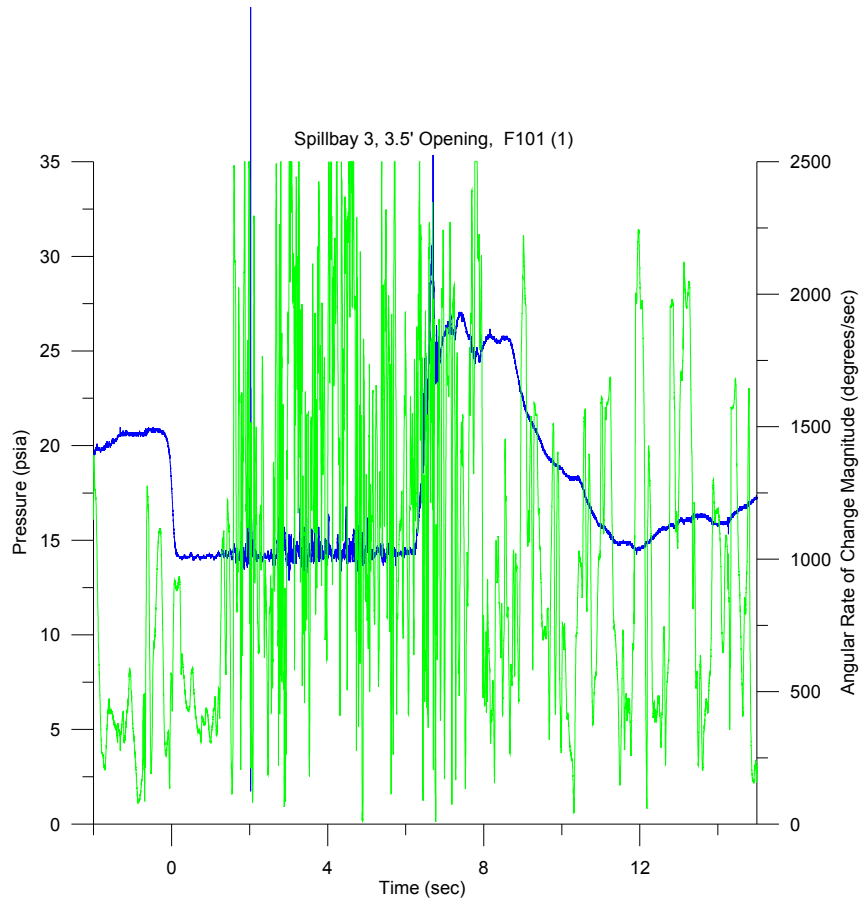


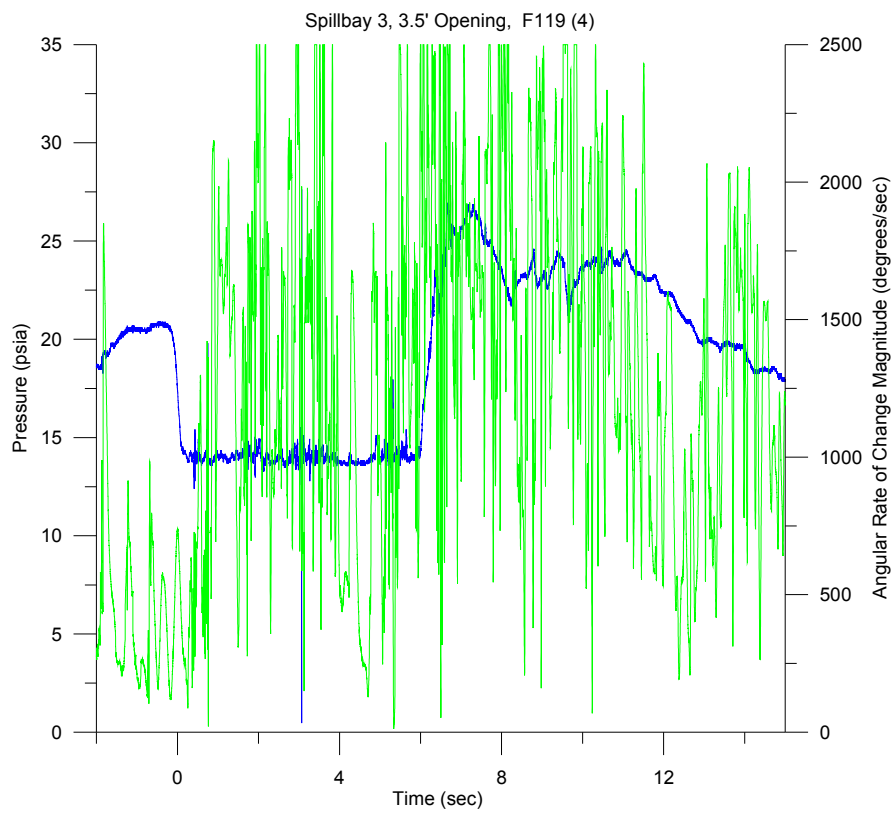
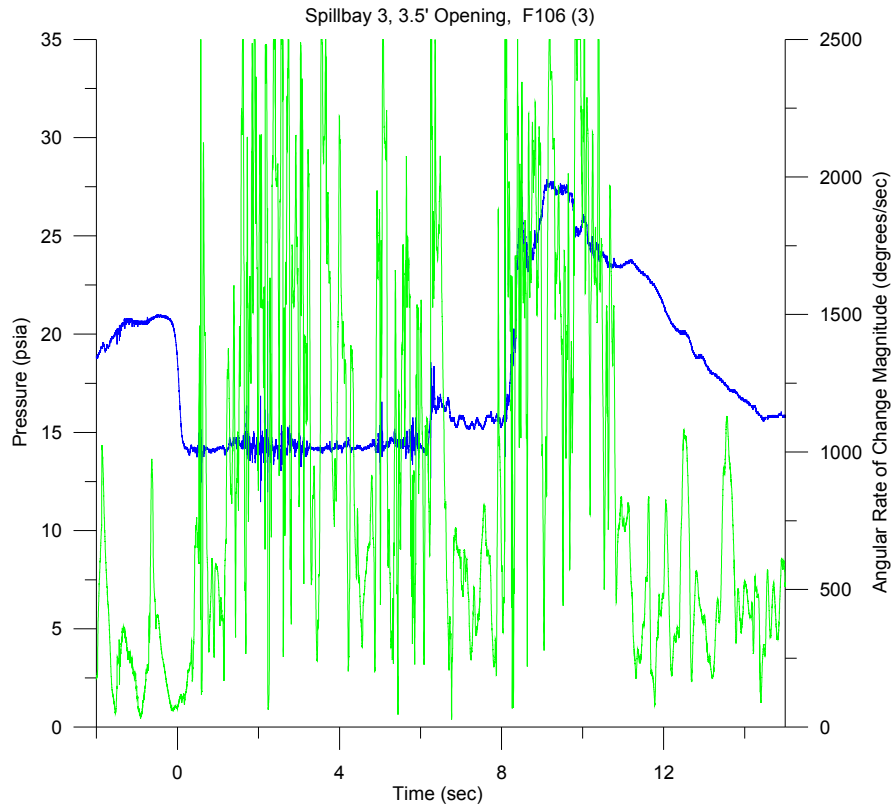




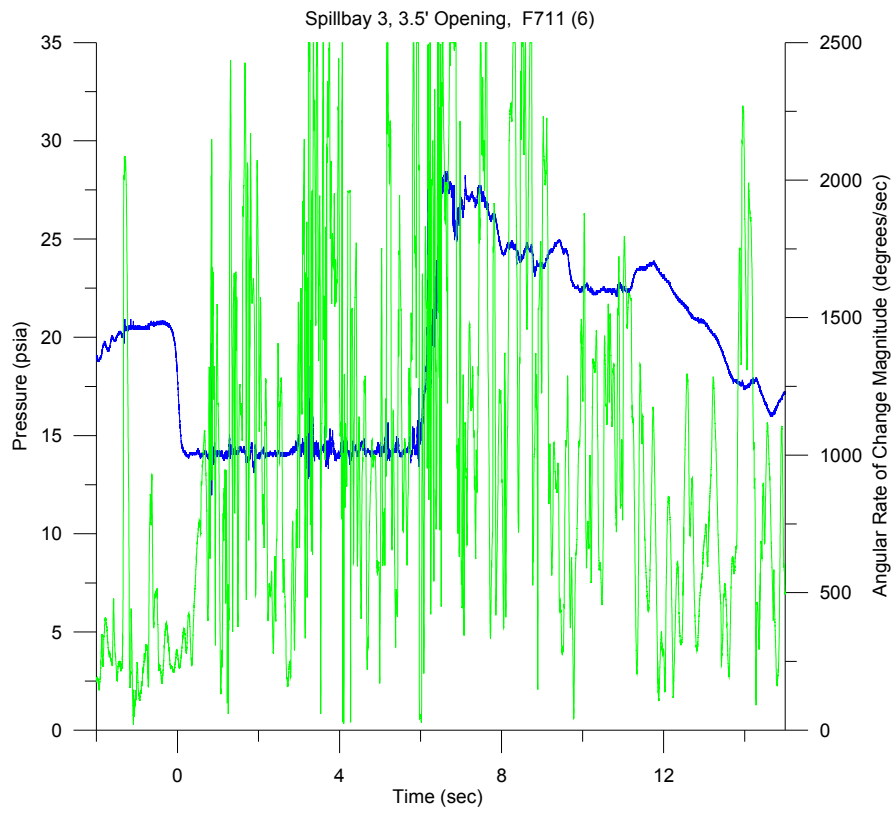
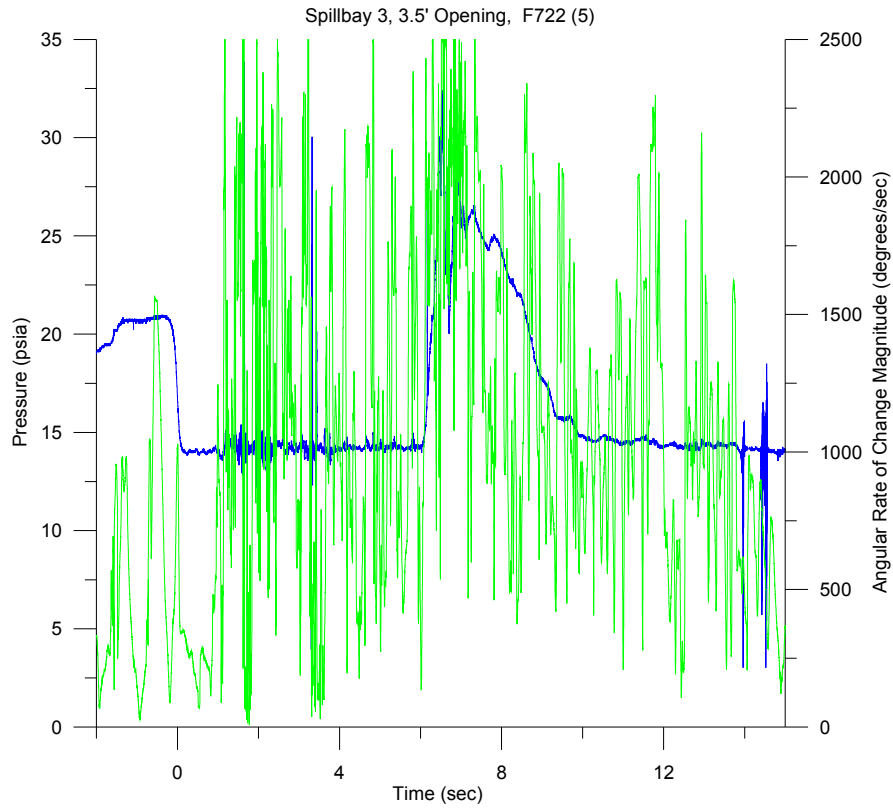
## **Detroit Dam Spillway Evaluation**

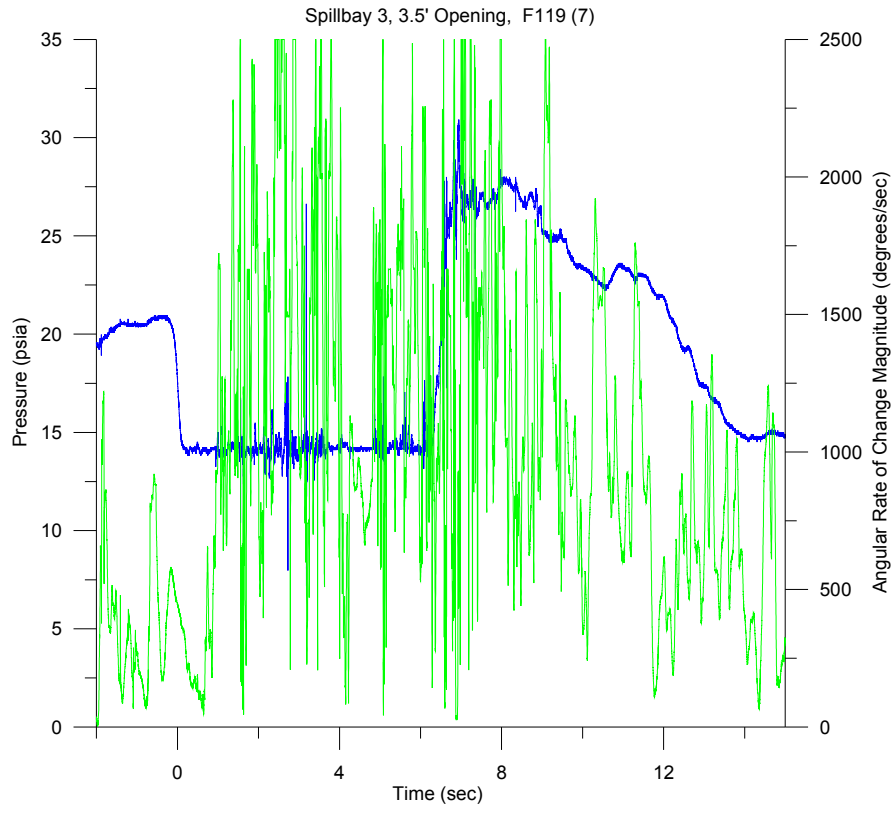
### **Spillbay 3, 3.5-ft Gate Opening**





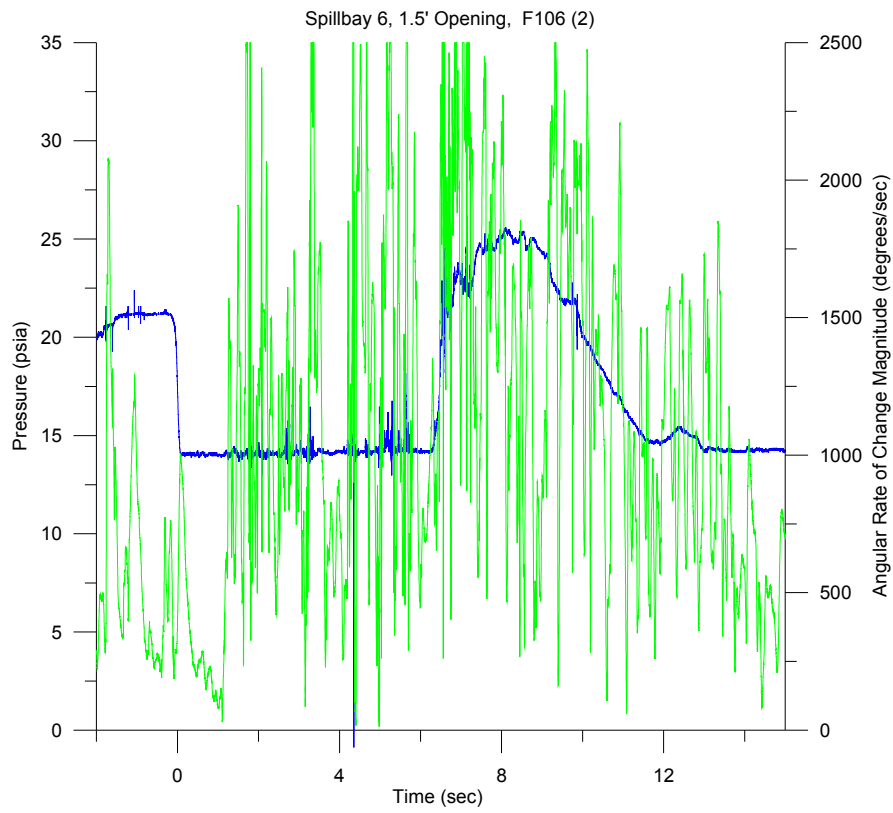
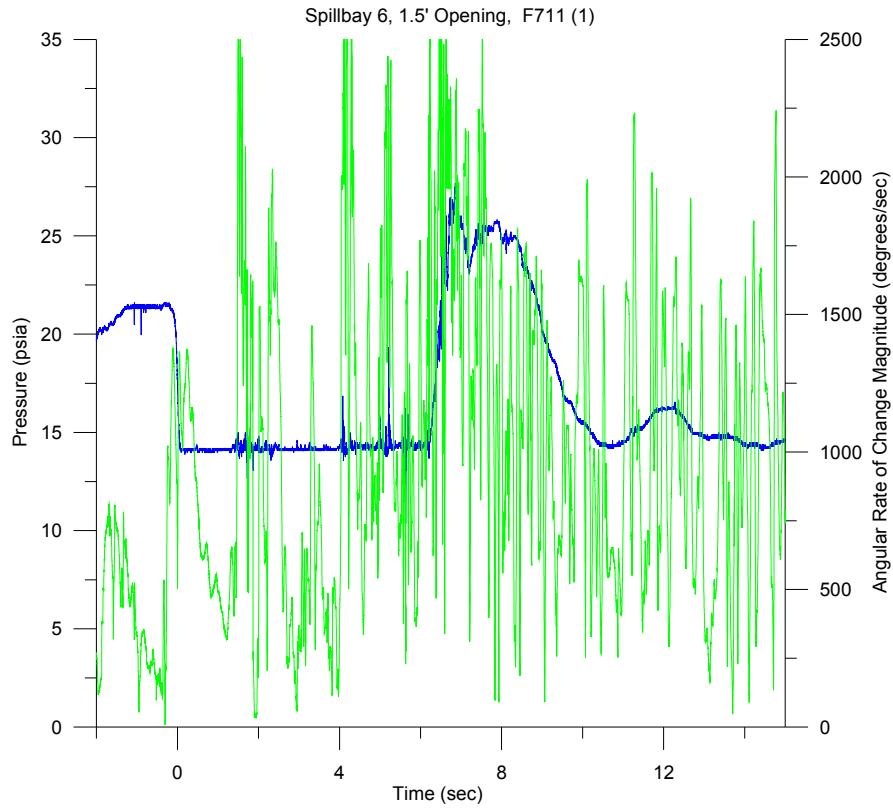


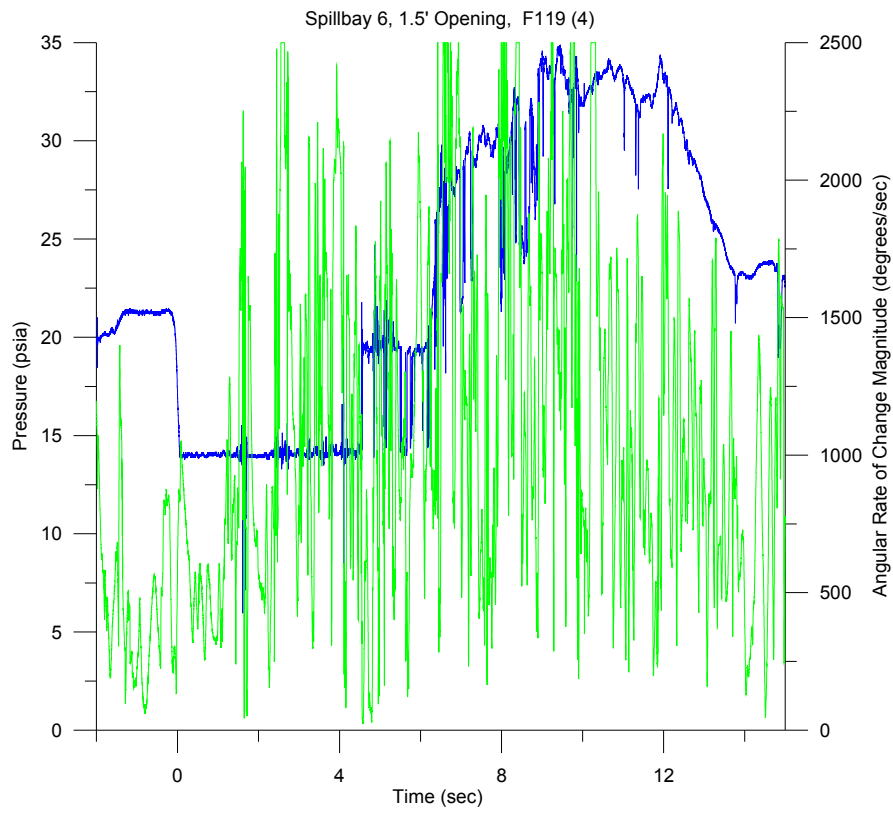
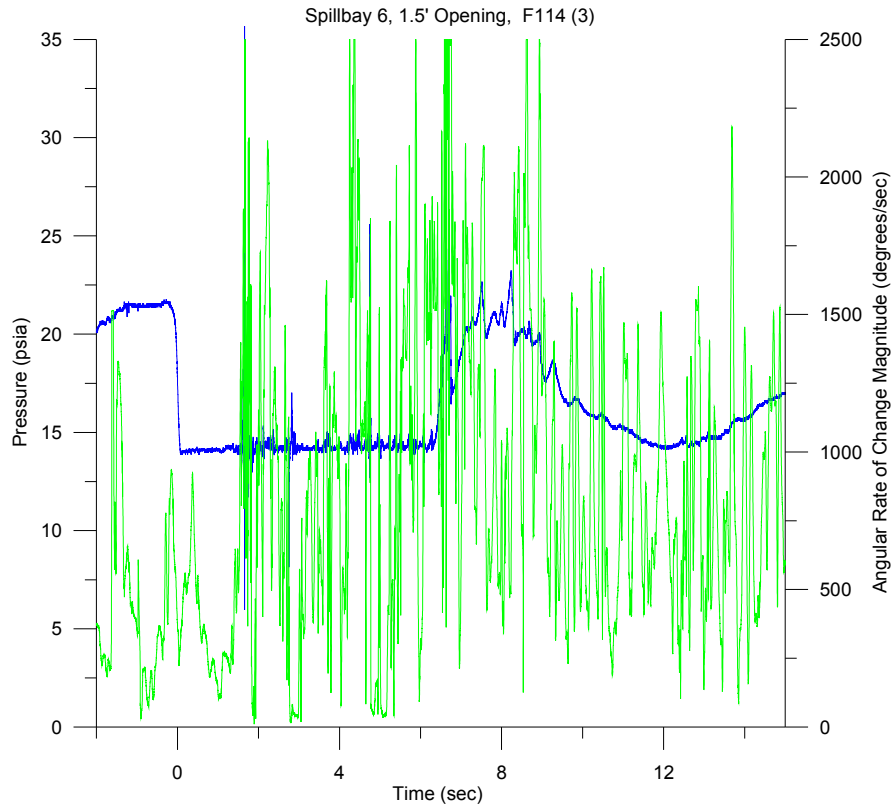


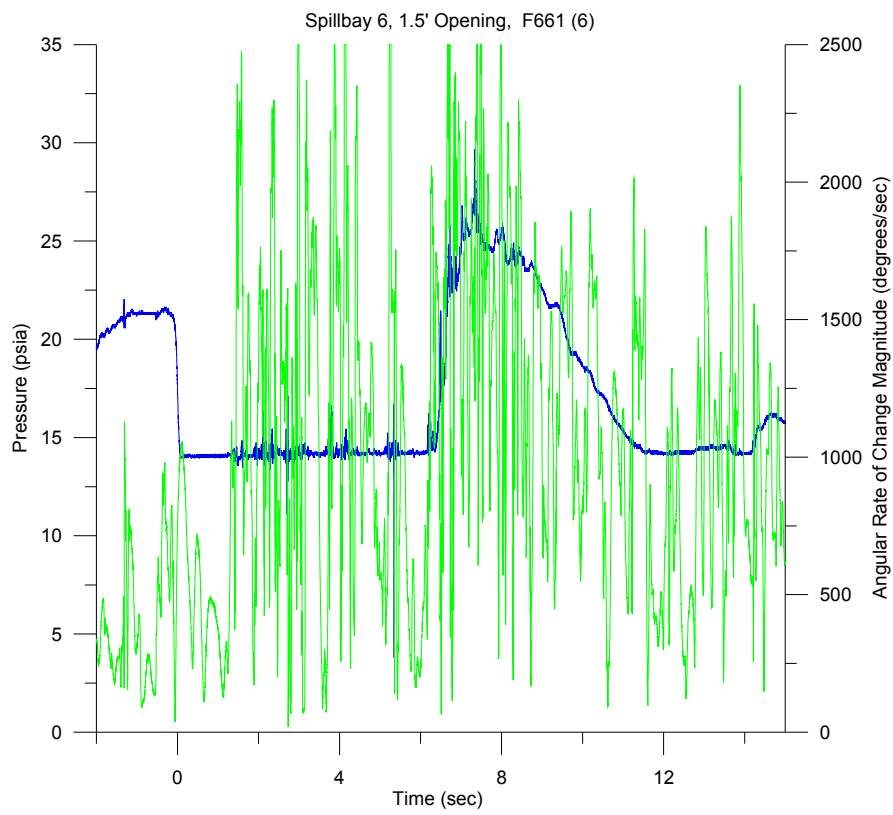
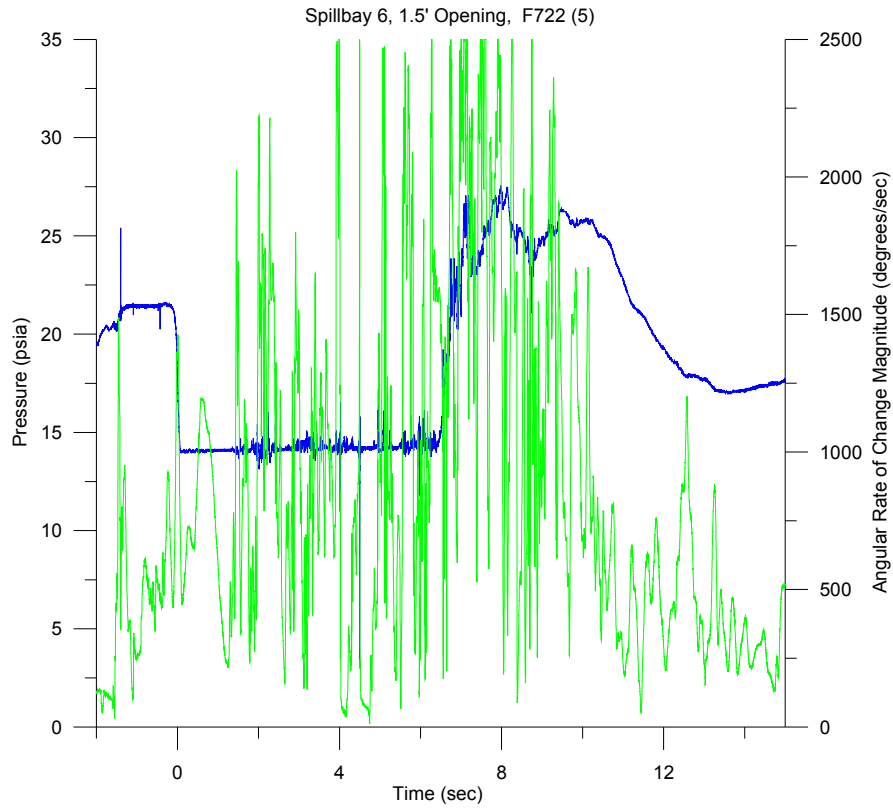


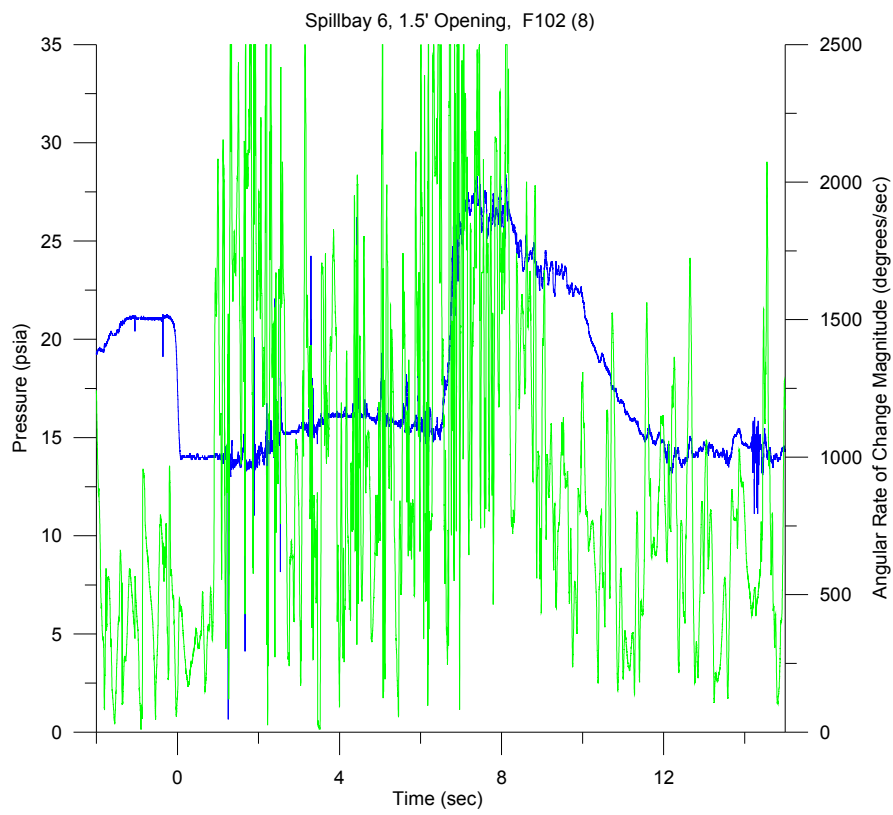
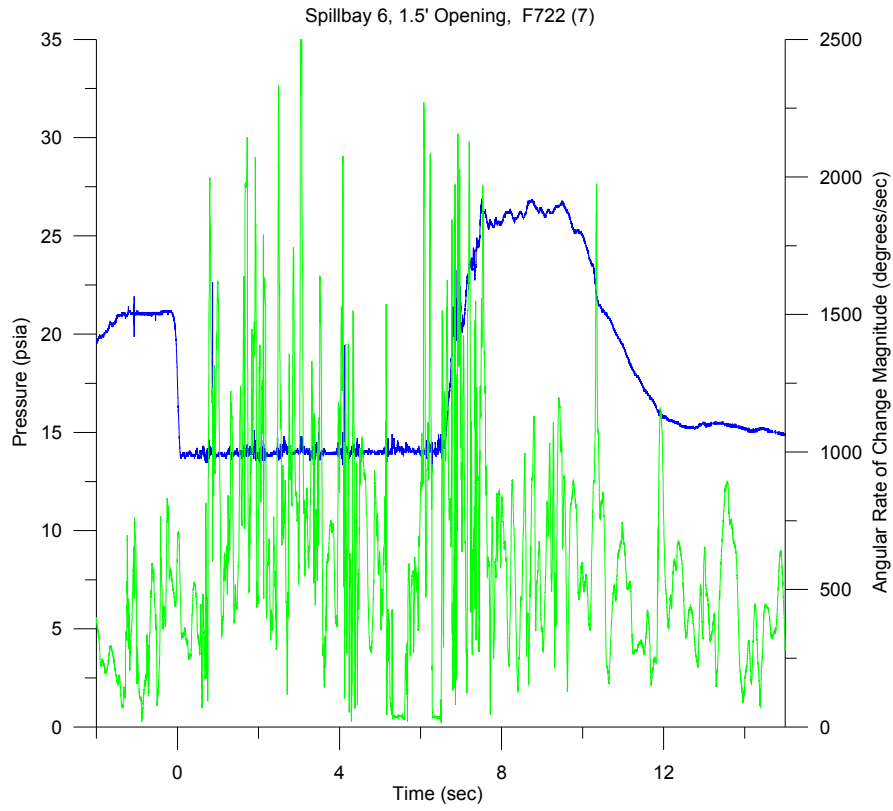
## **Detroit Dam Spillway Evaluation**

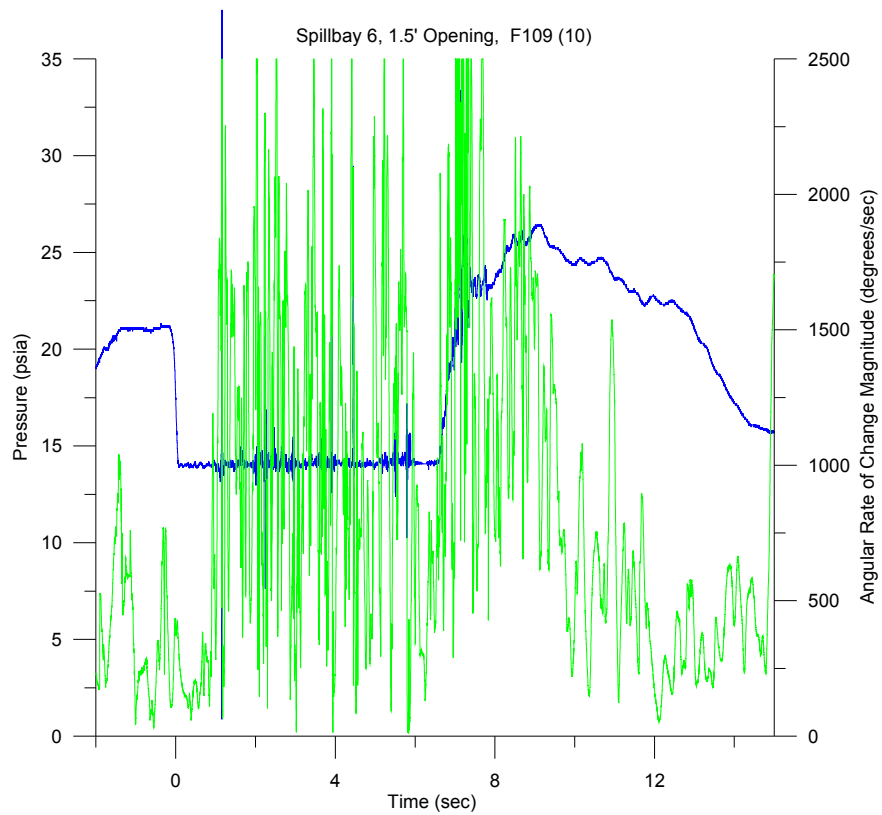
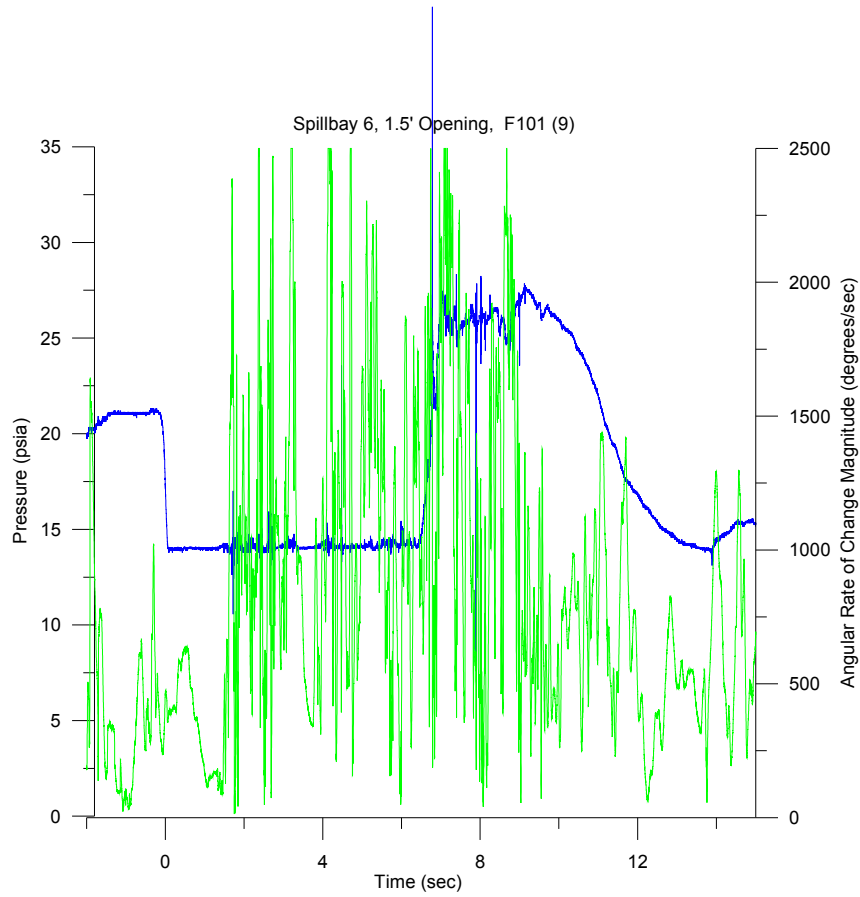
### **Spillbay 6, 1.5-ft Gate Opening**



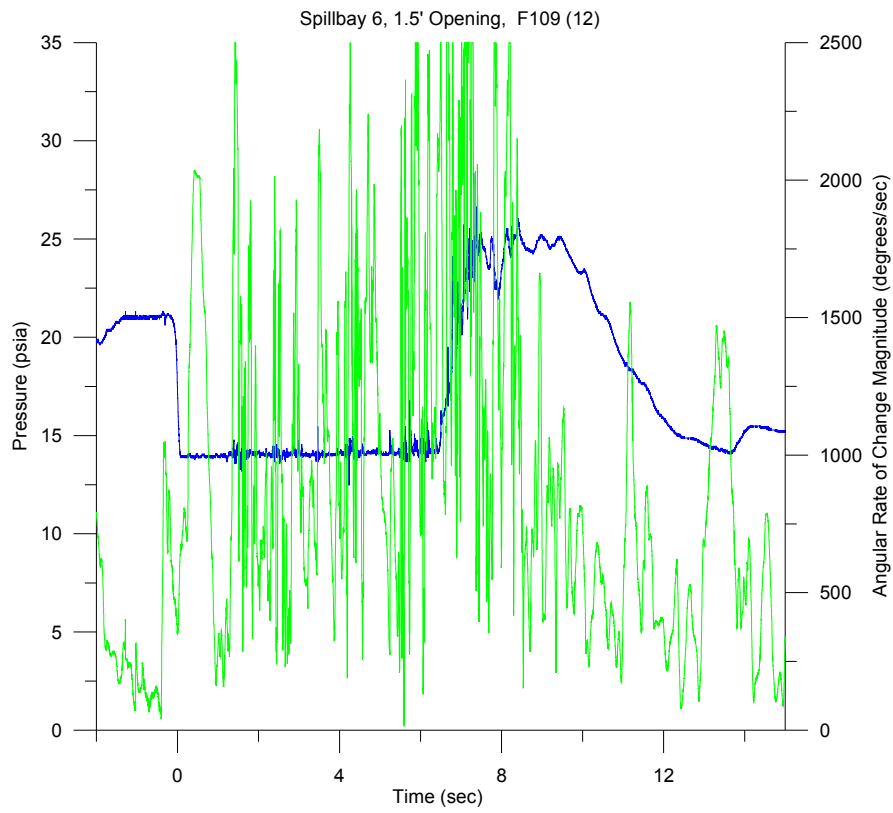
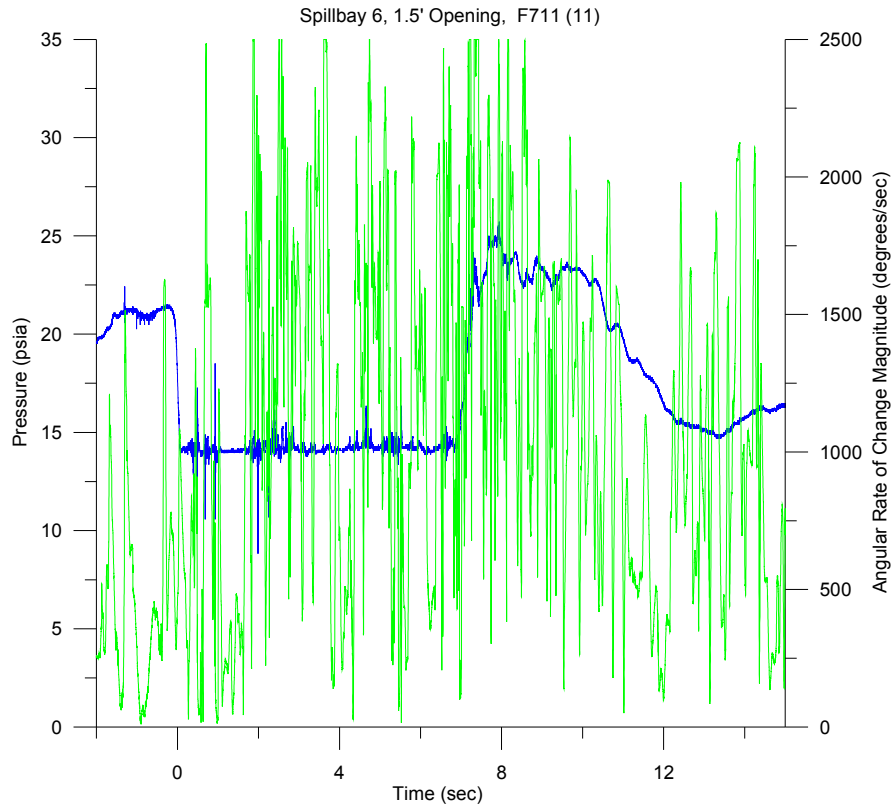


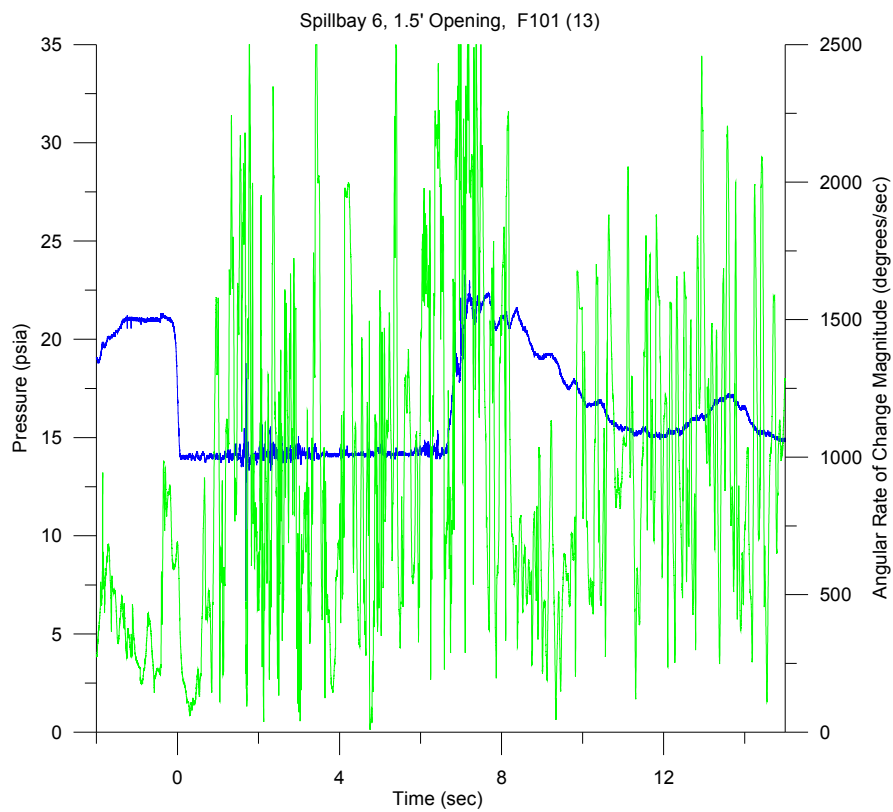
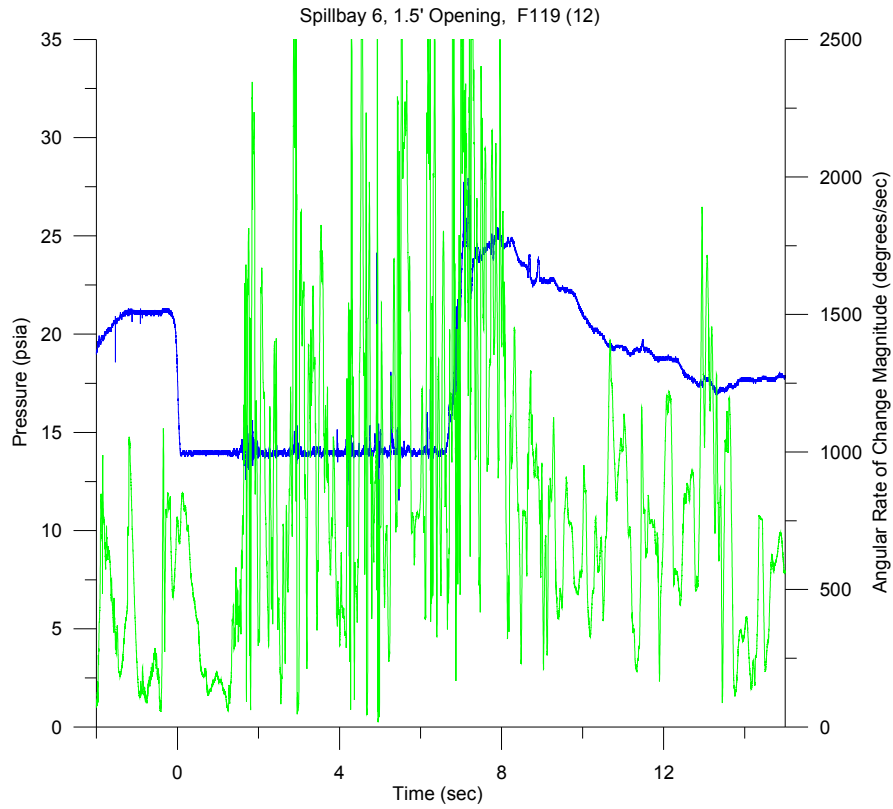


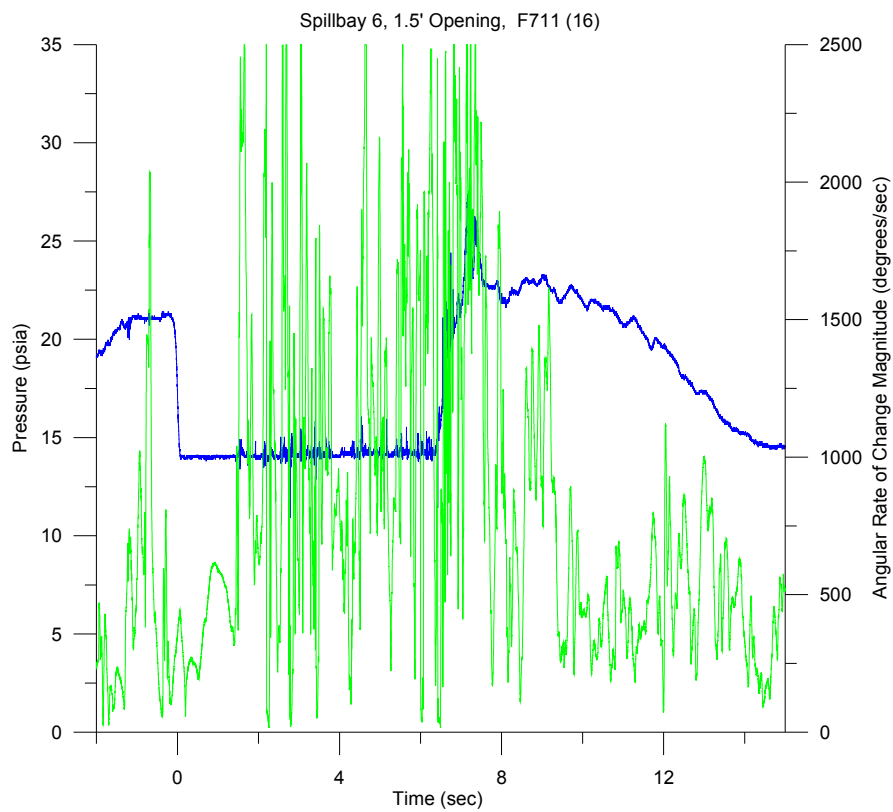
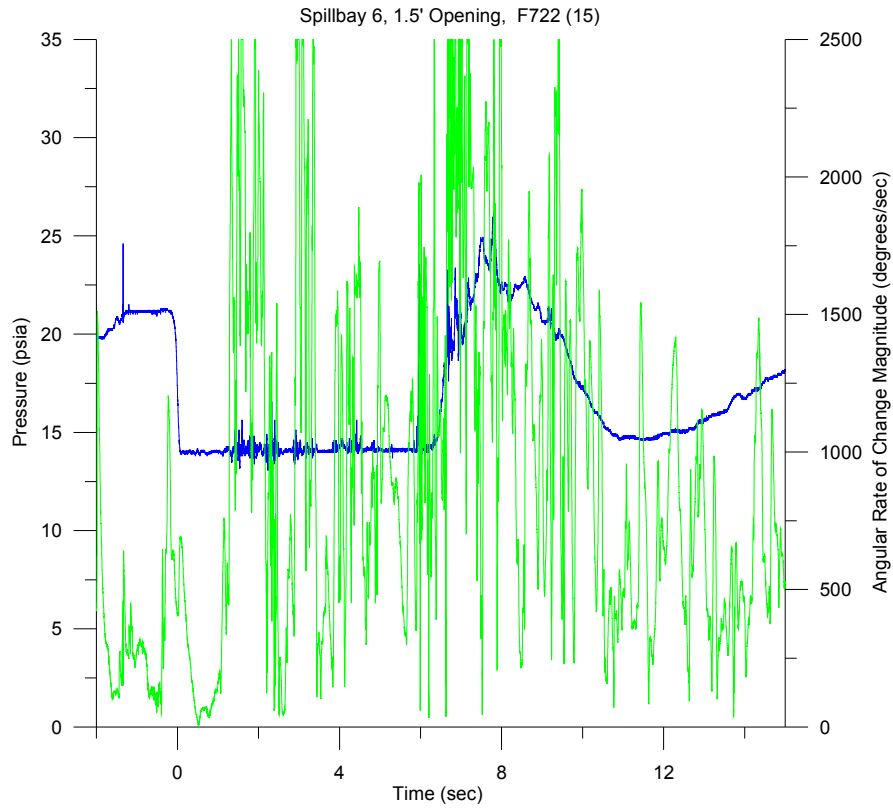


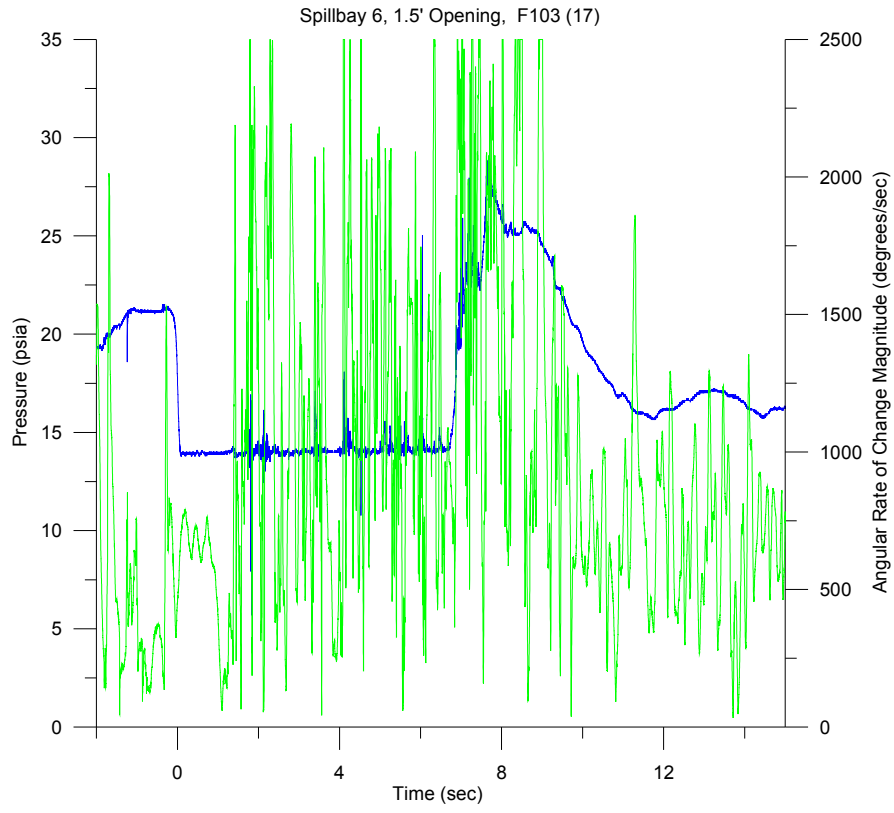






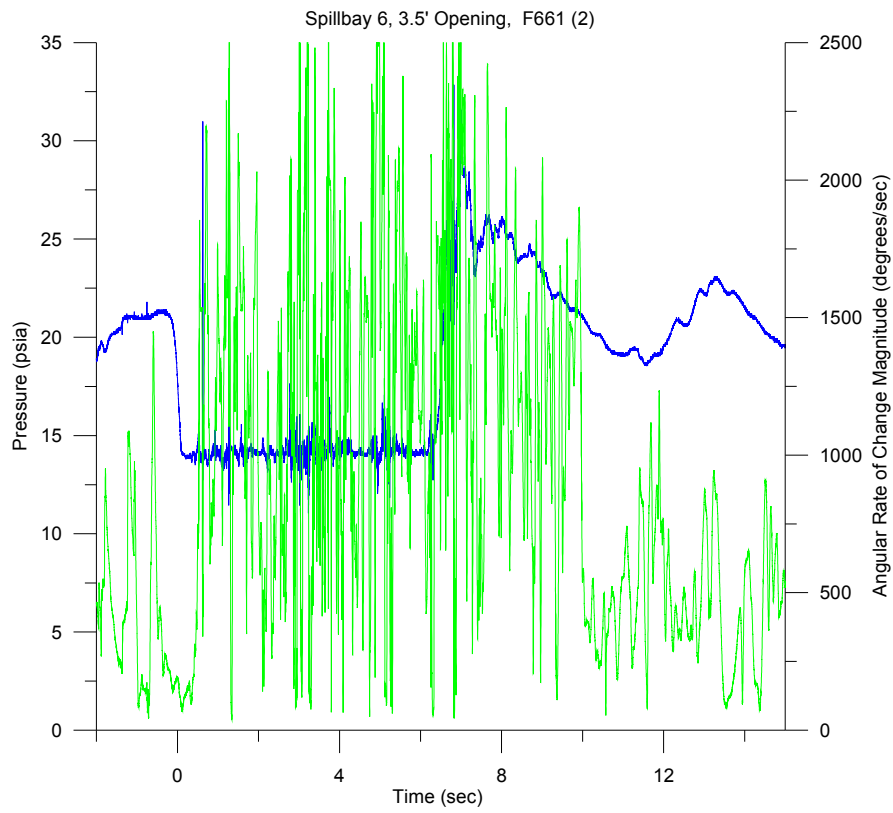
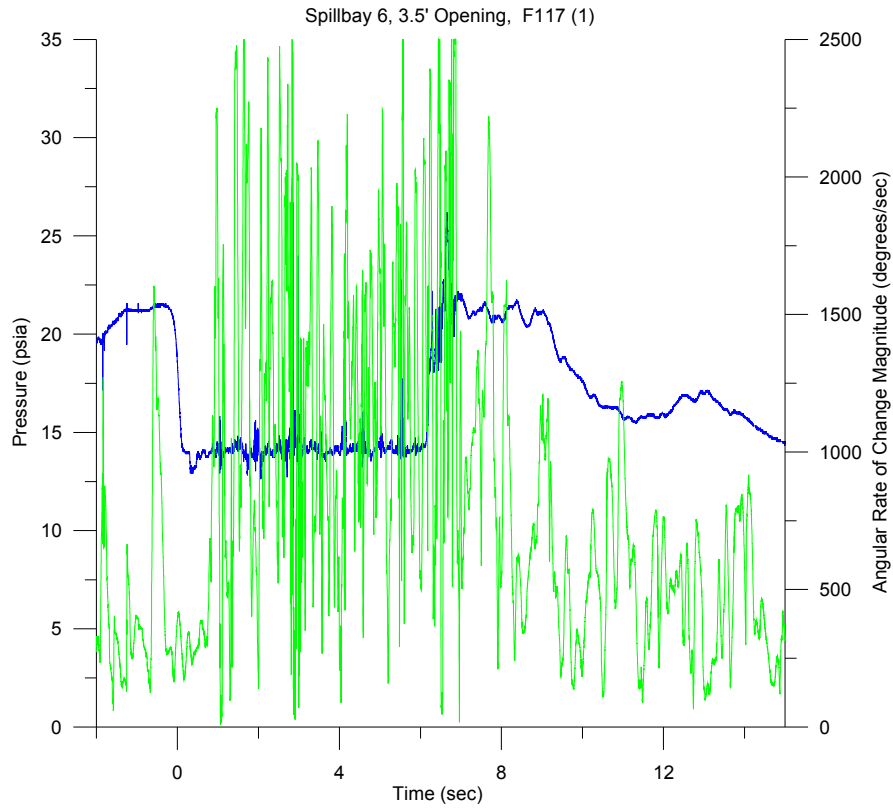


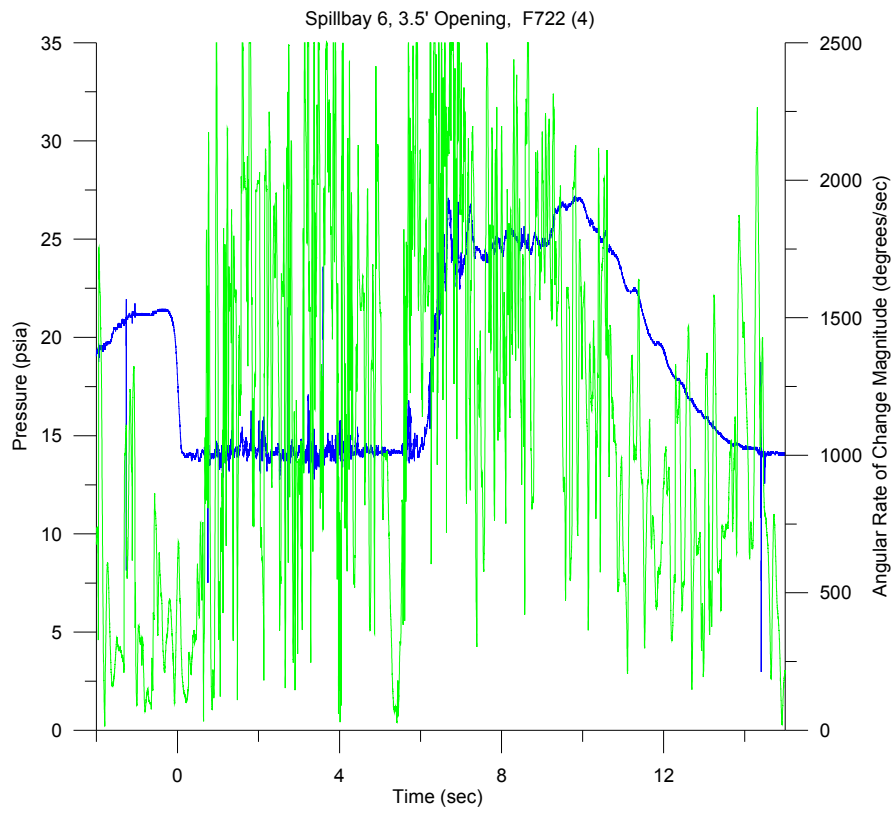
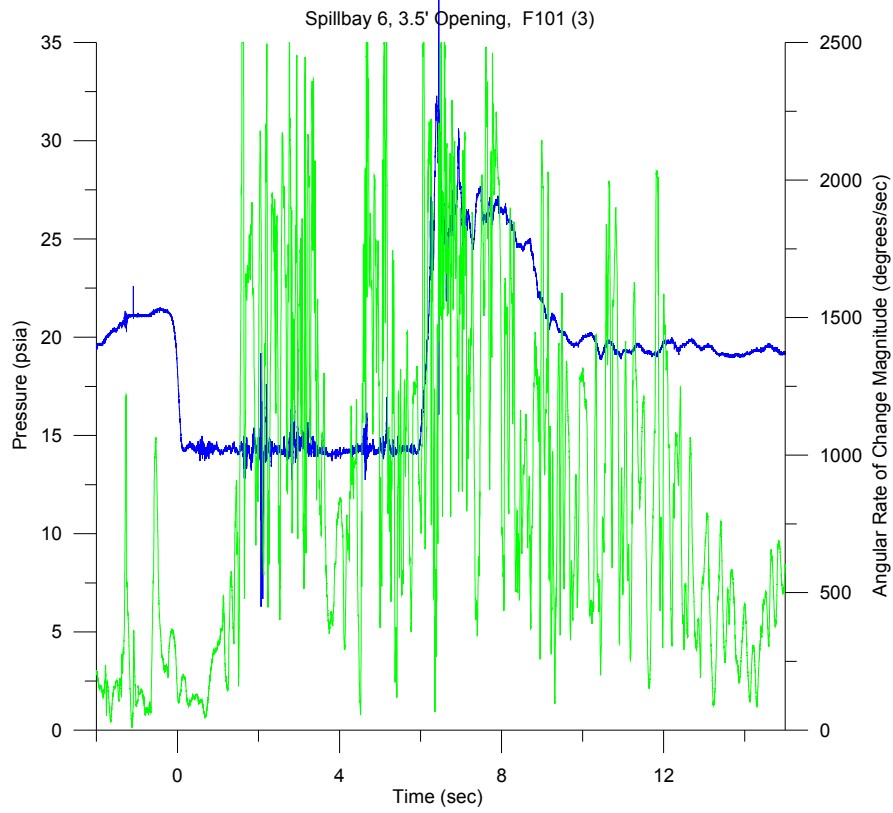


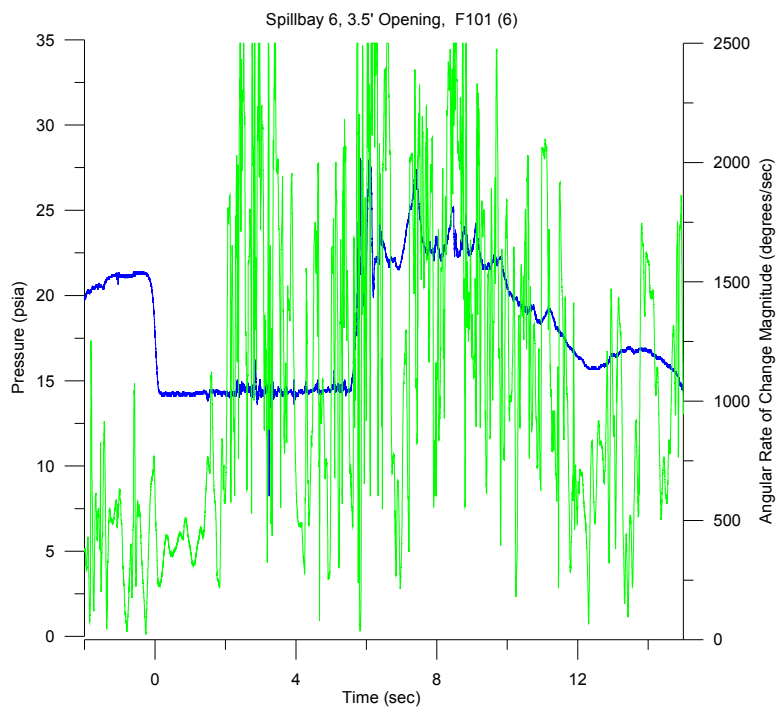
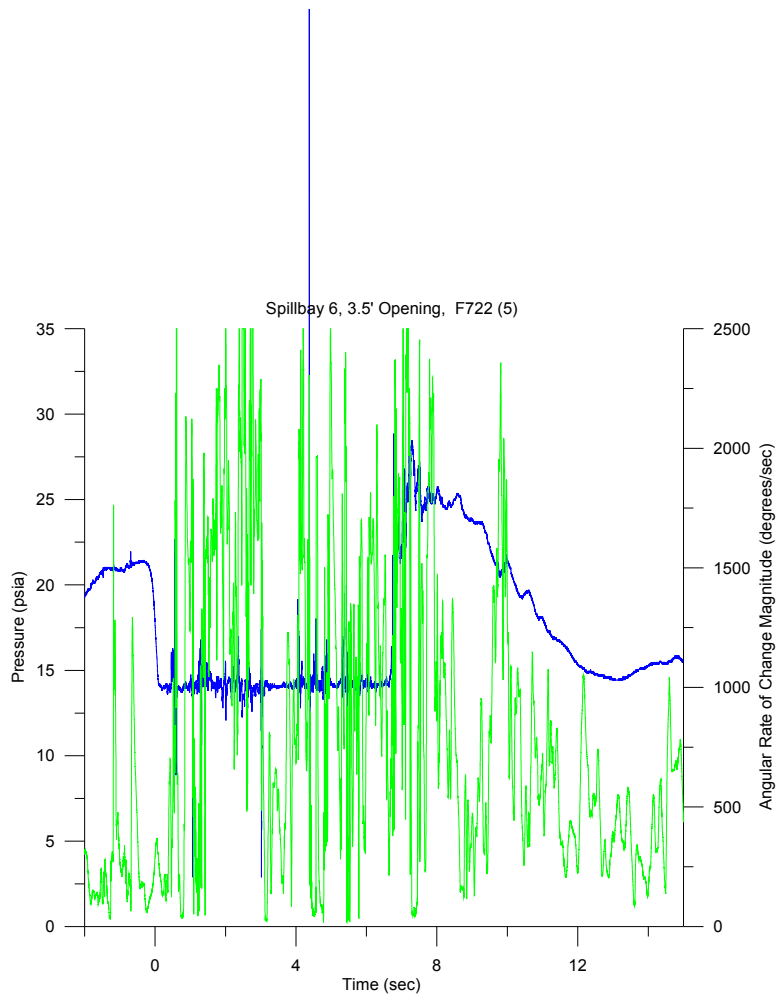


## **Detroit Dam Spillway Evaluation**

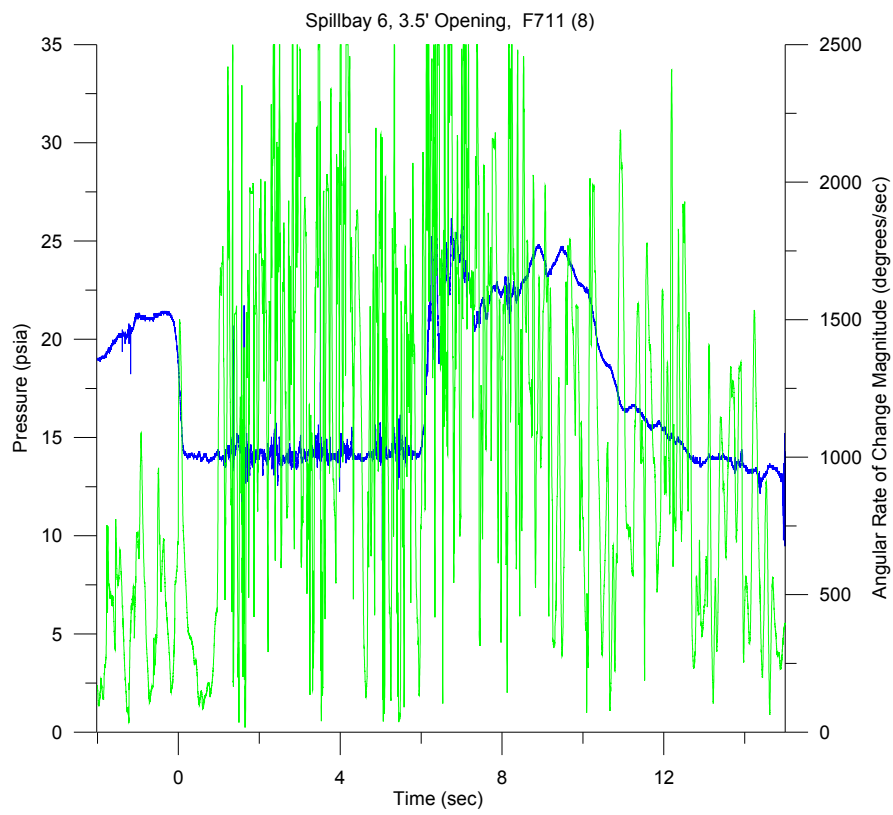
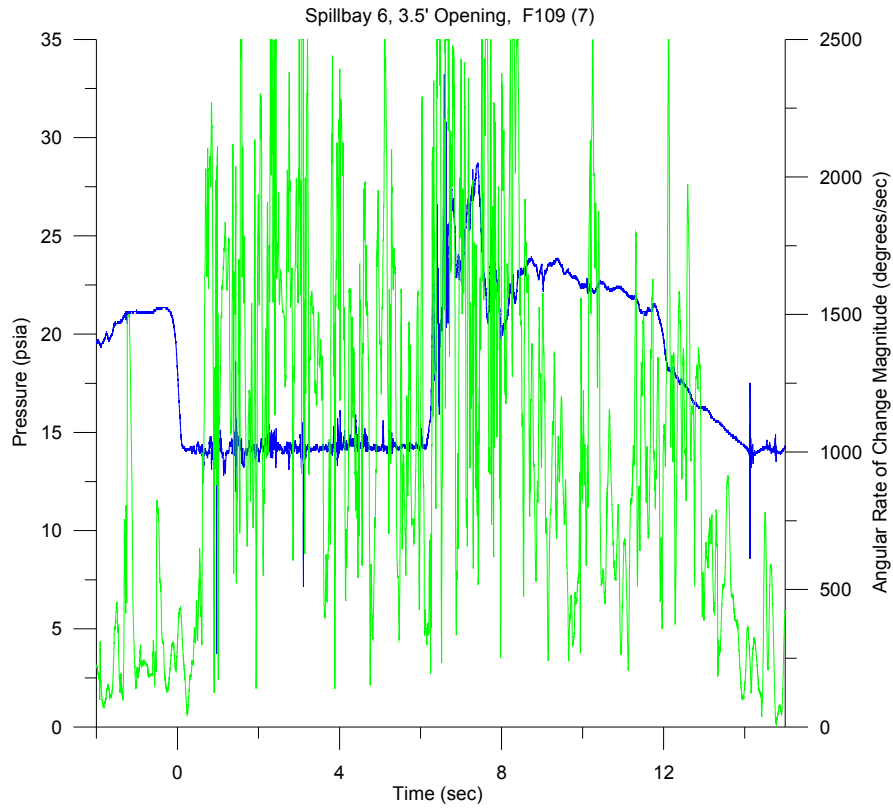
### **Spillbay 6, 3.5 ft Gate Opening**

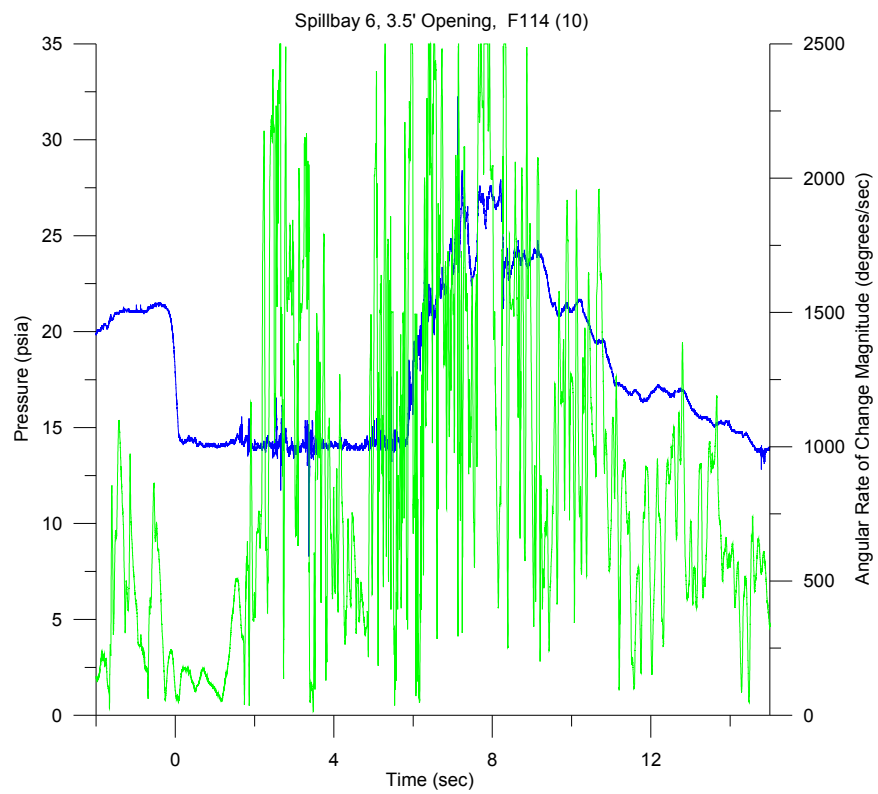
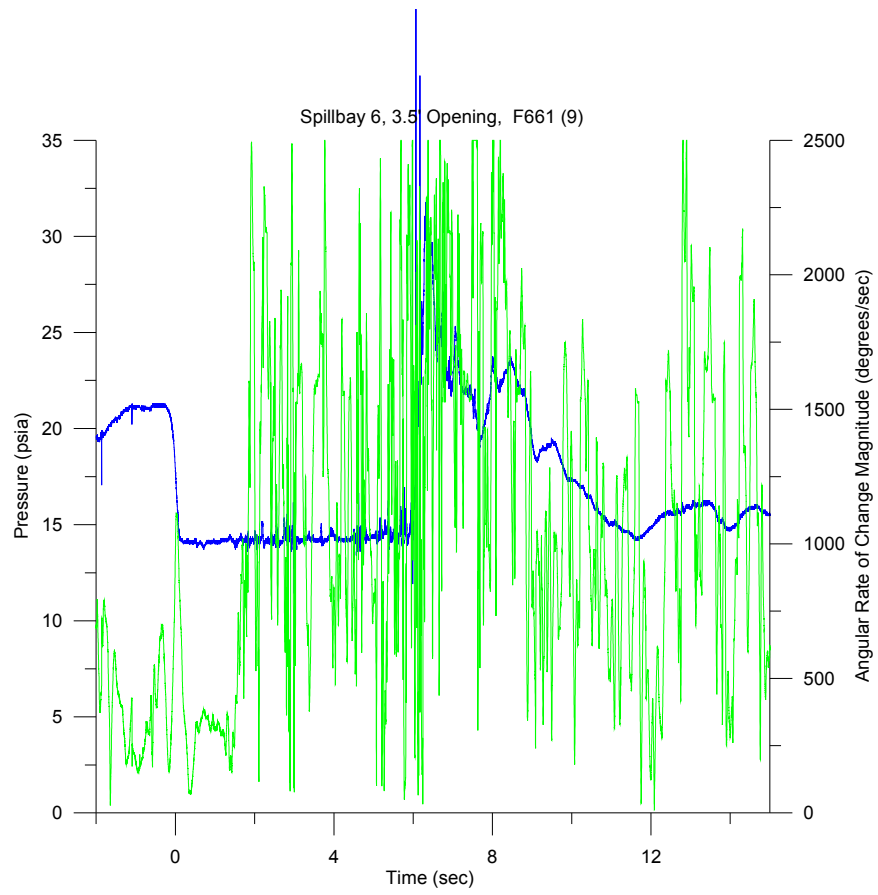


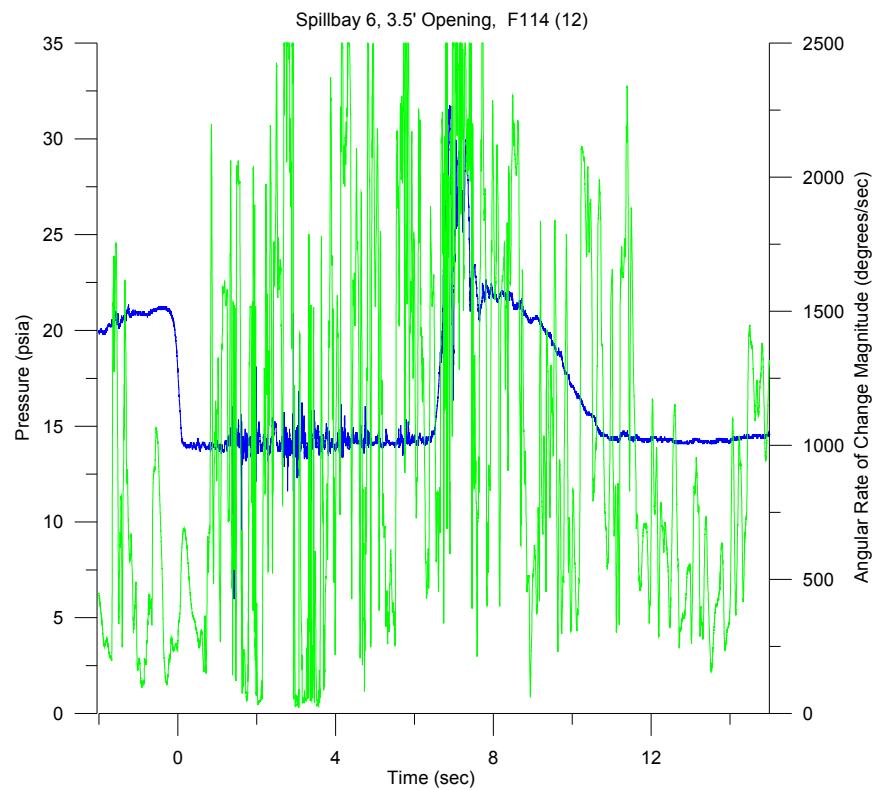
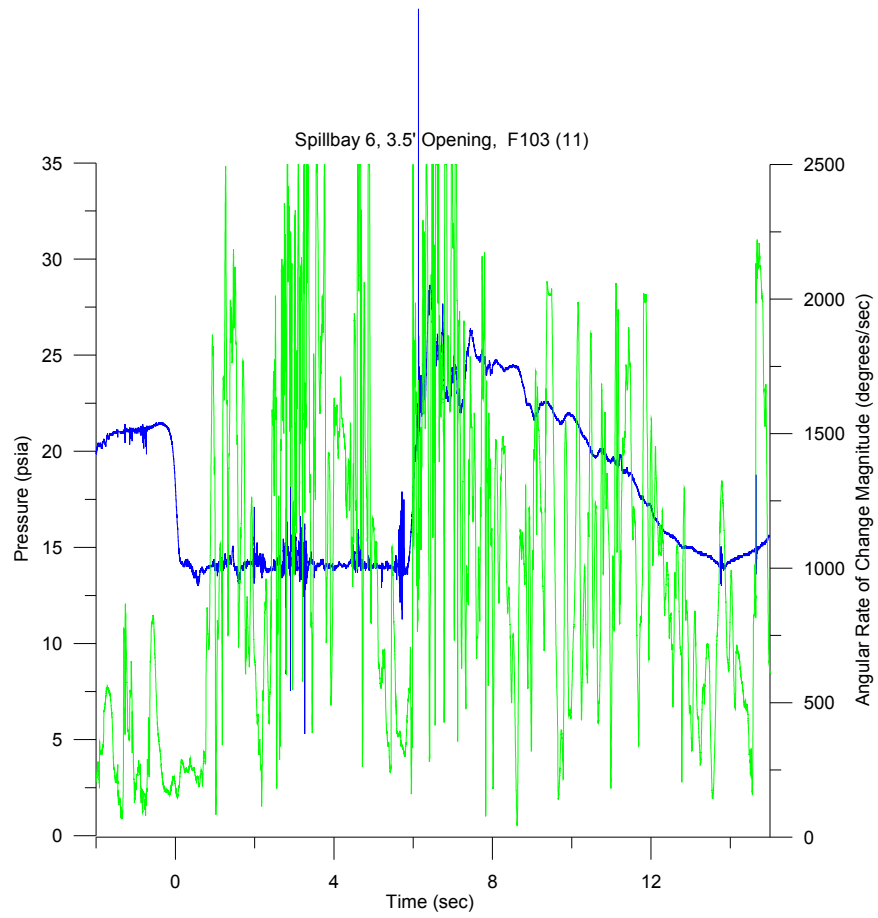


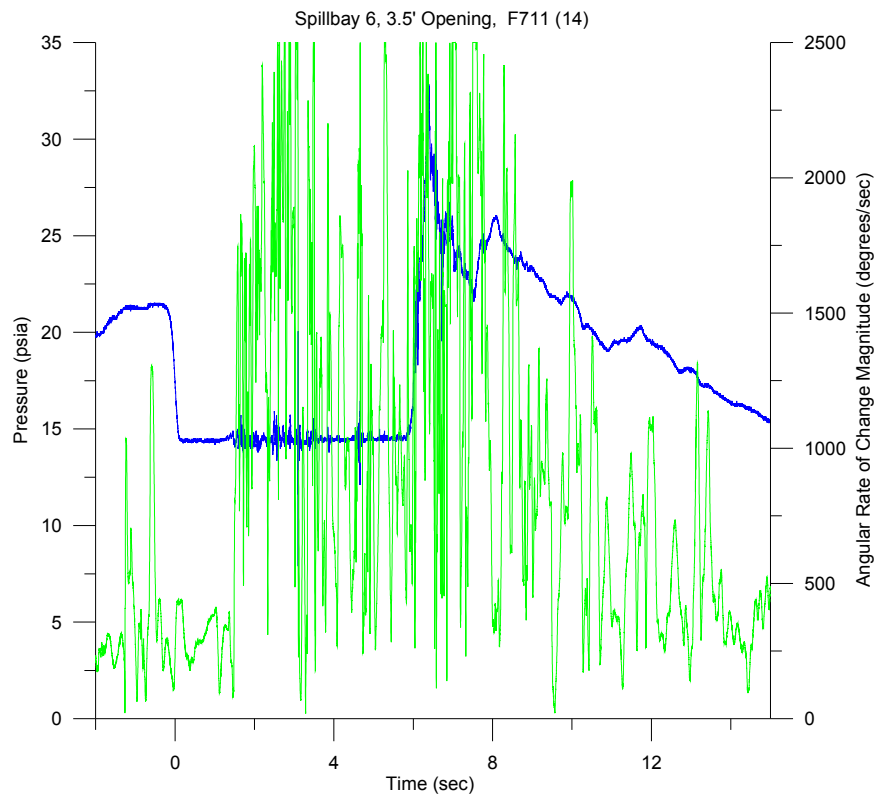
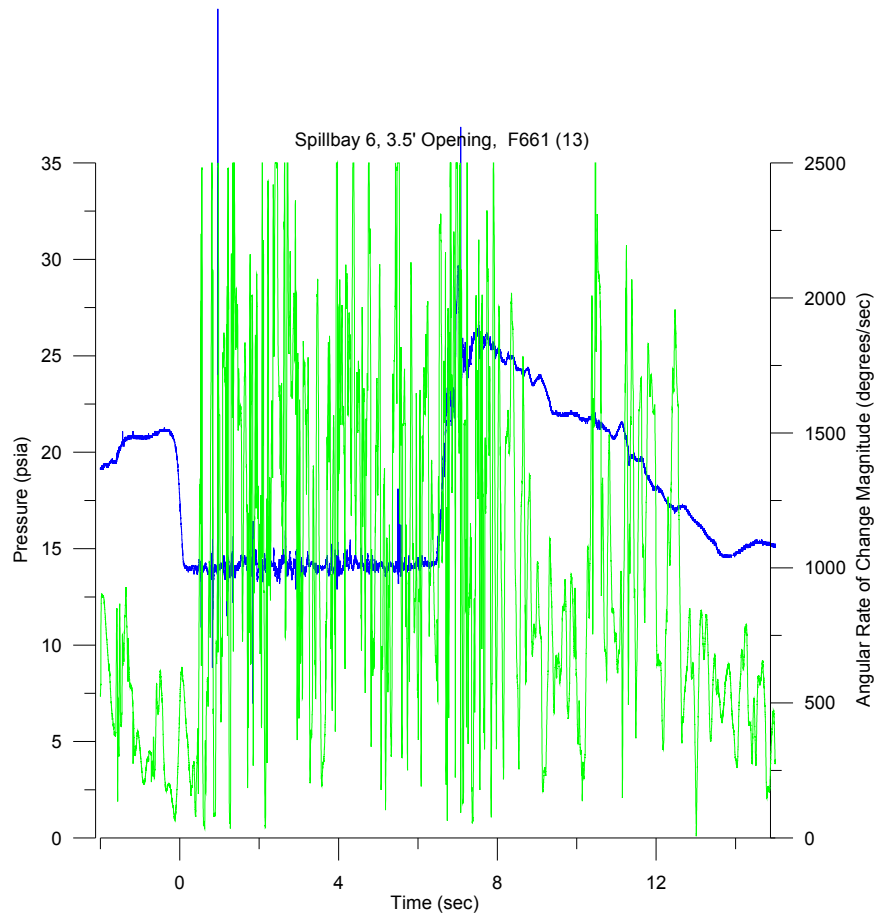


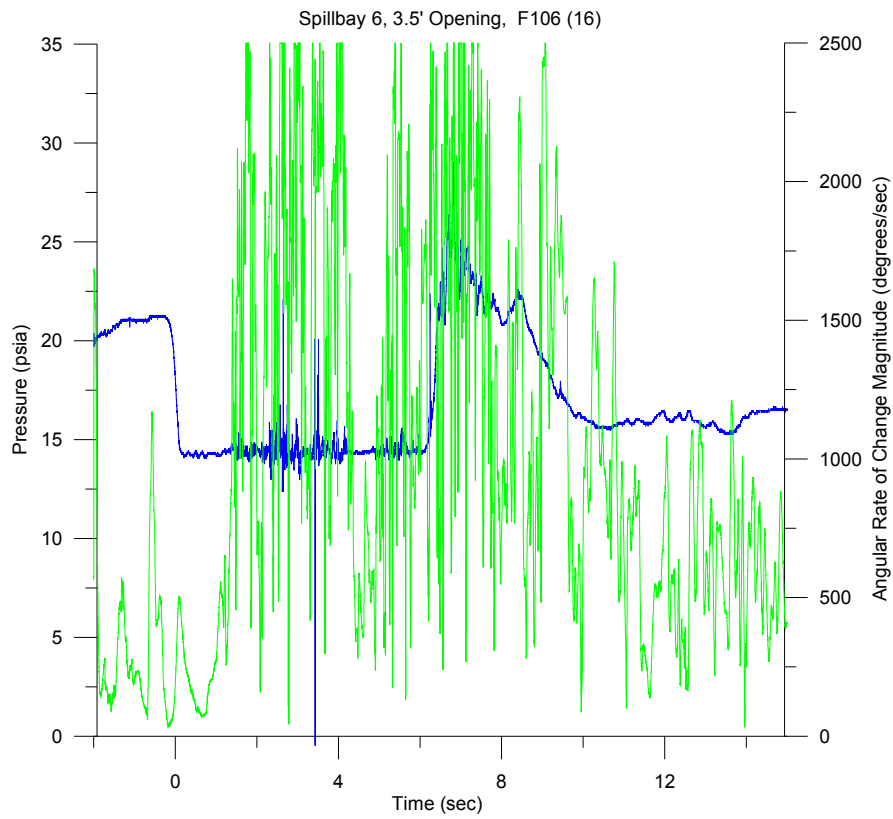
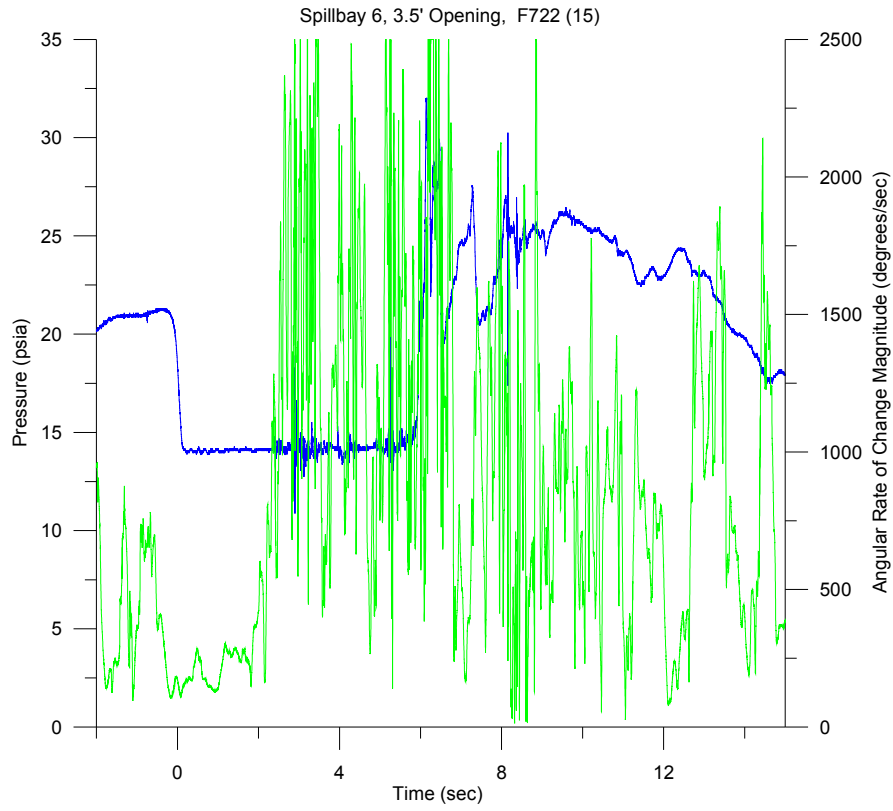


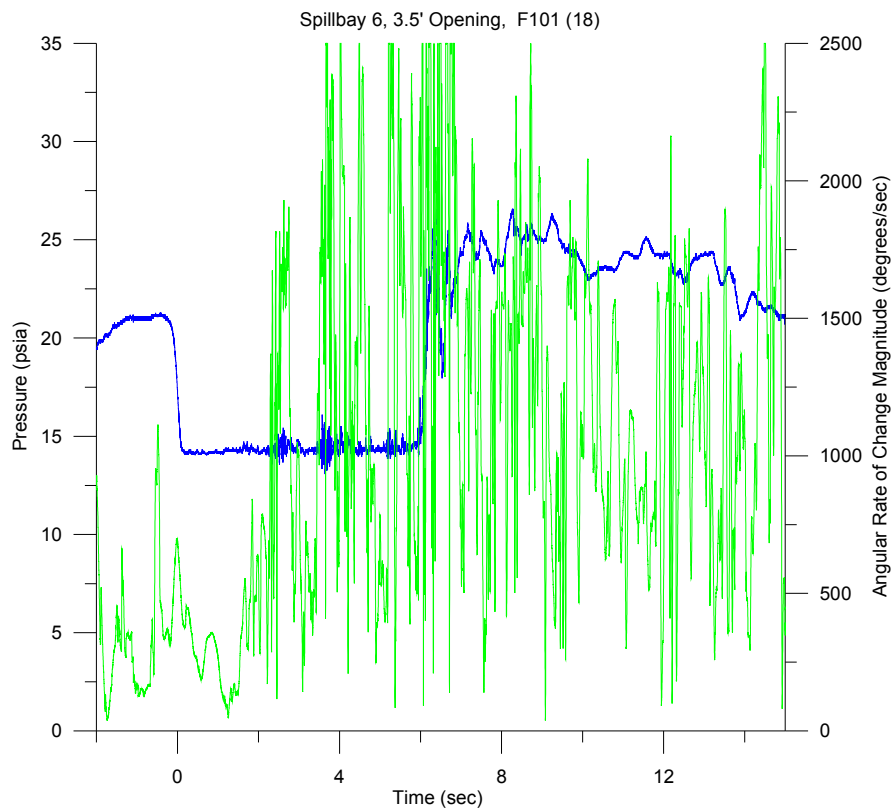
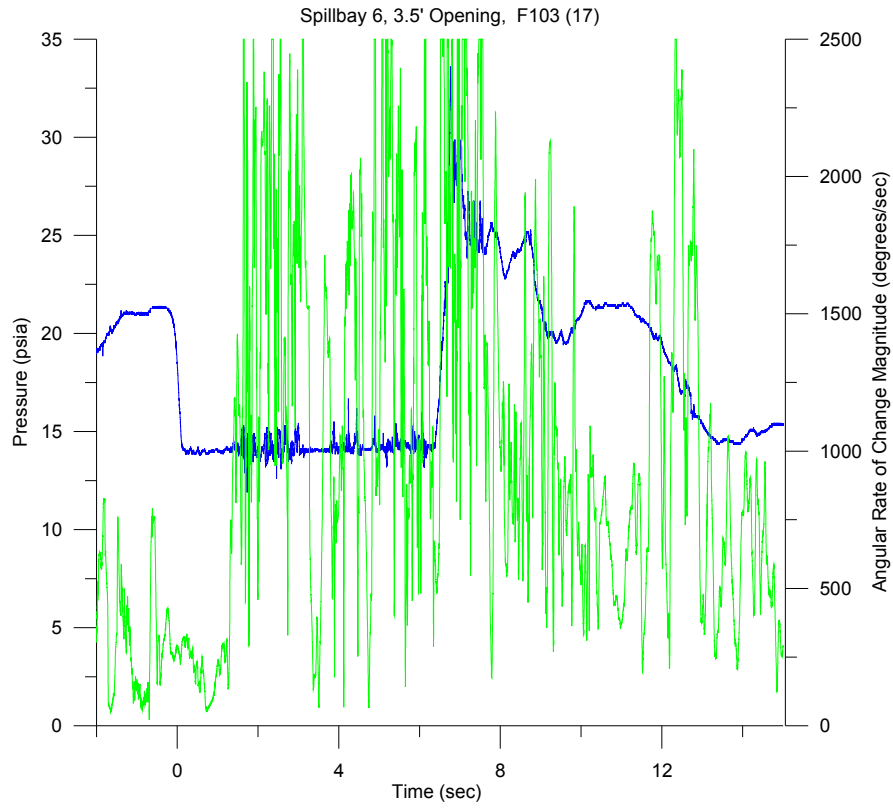


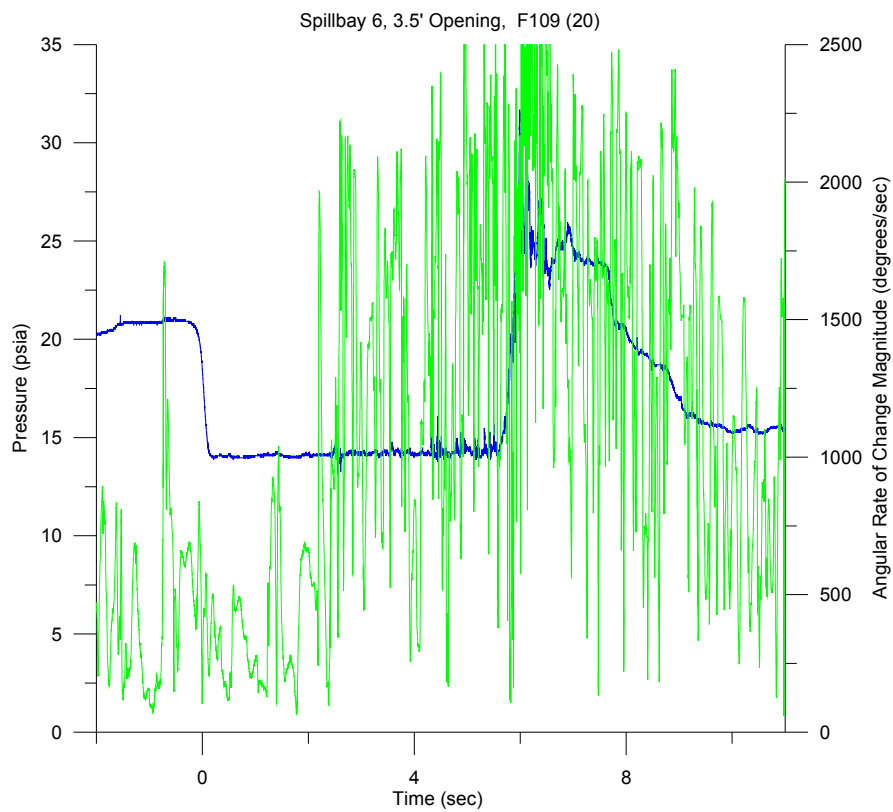
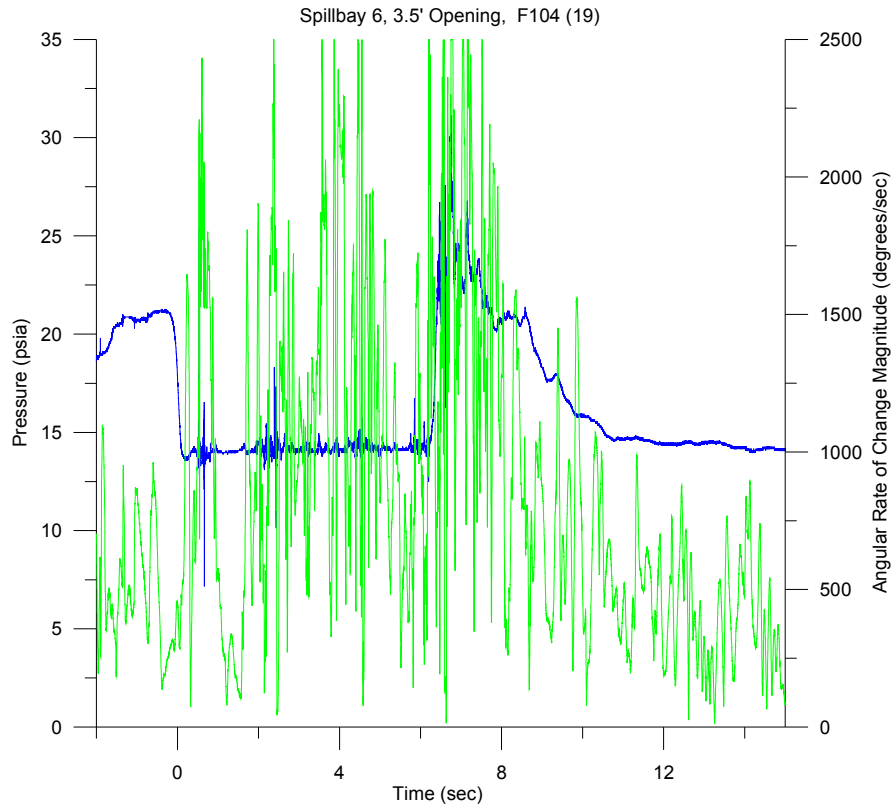


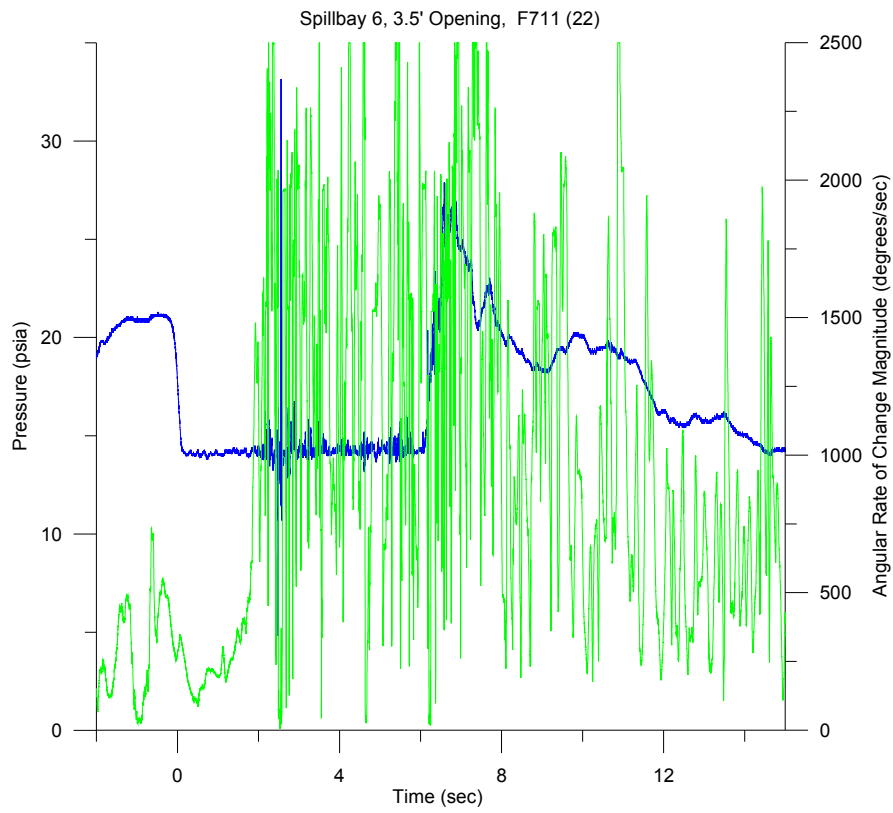
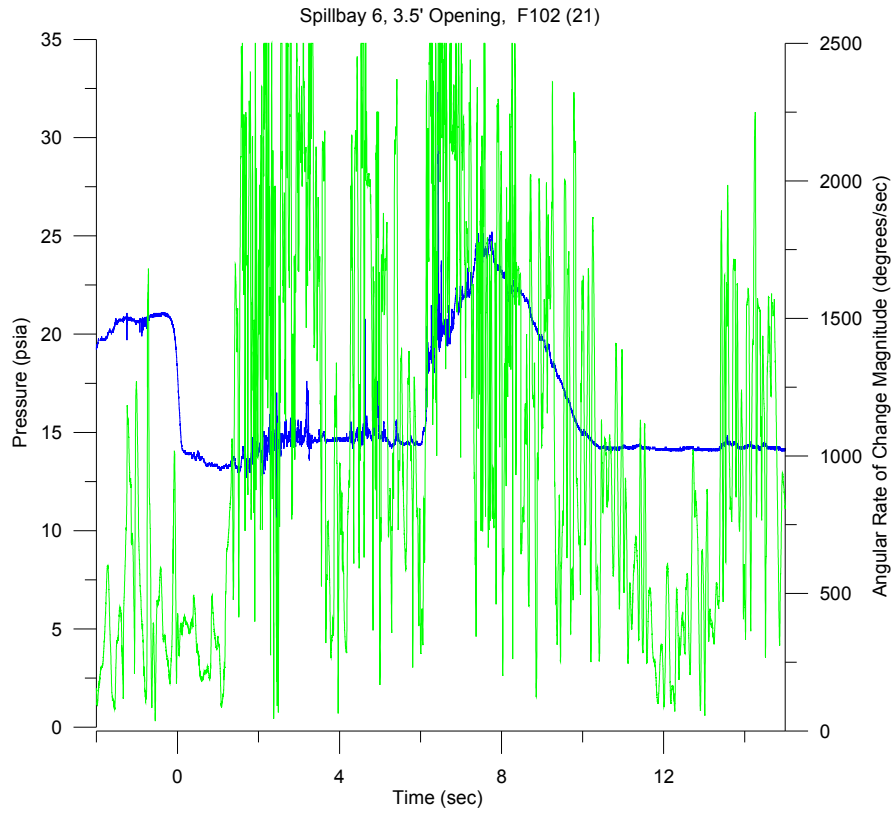




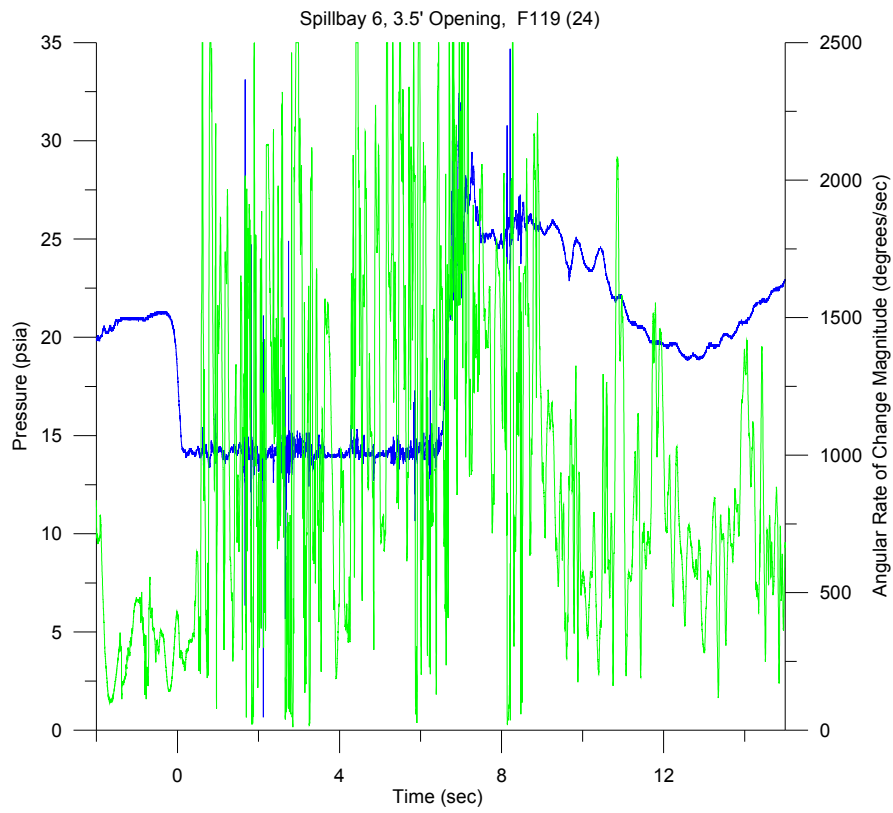
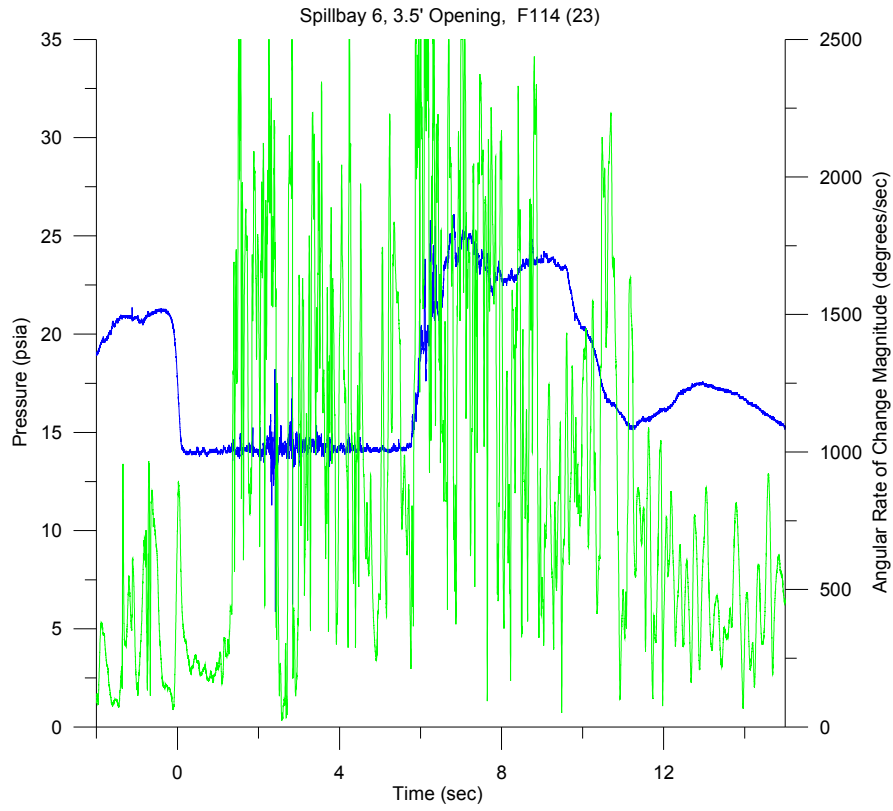


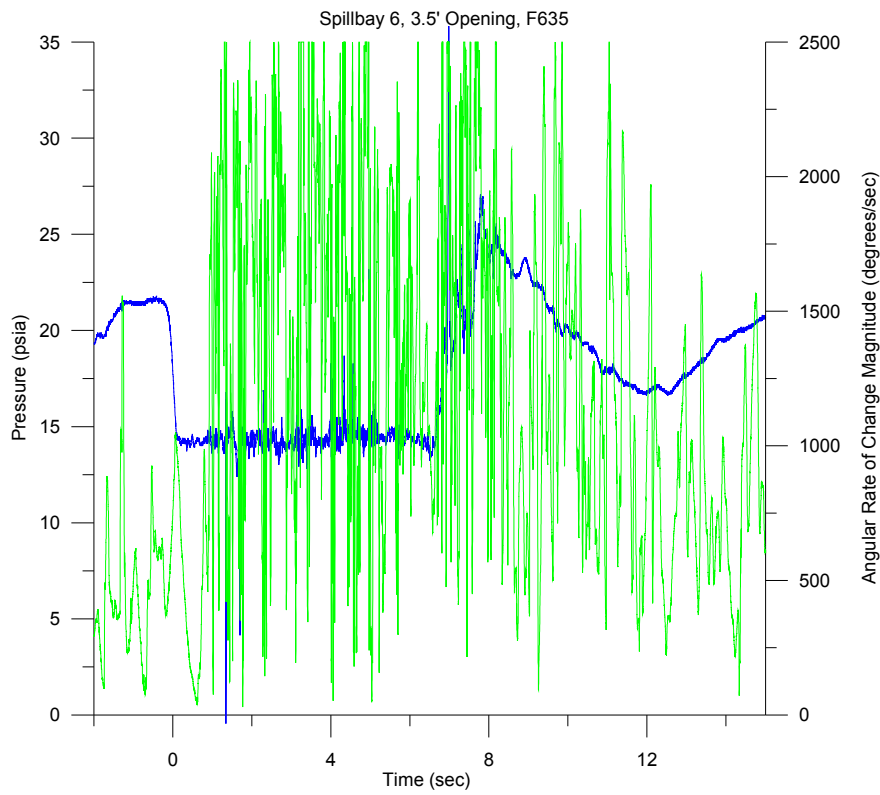
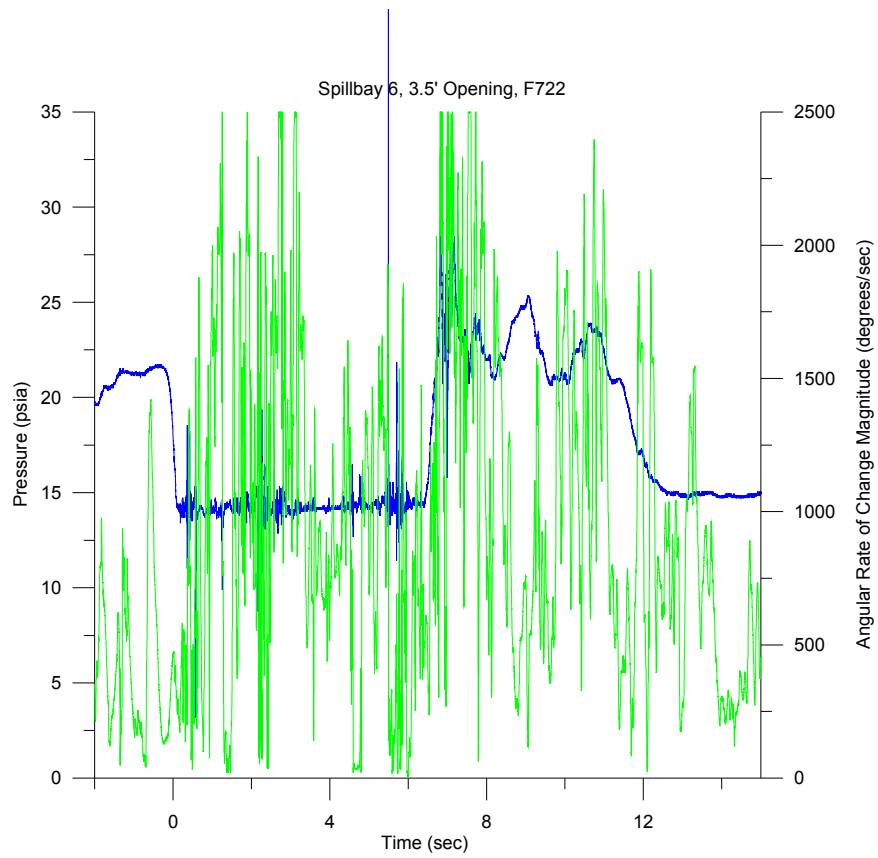






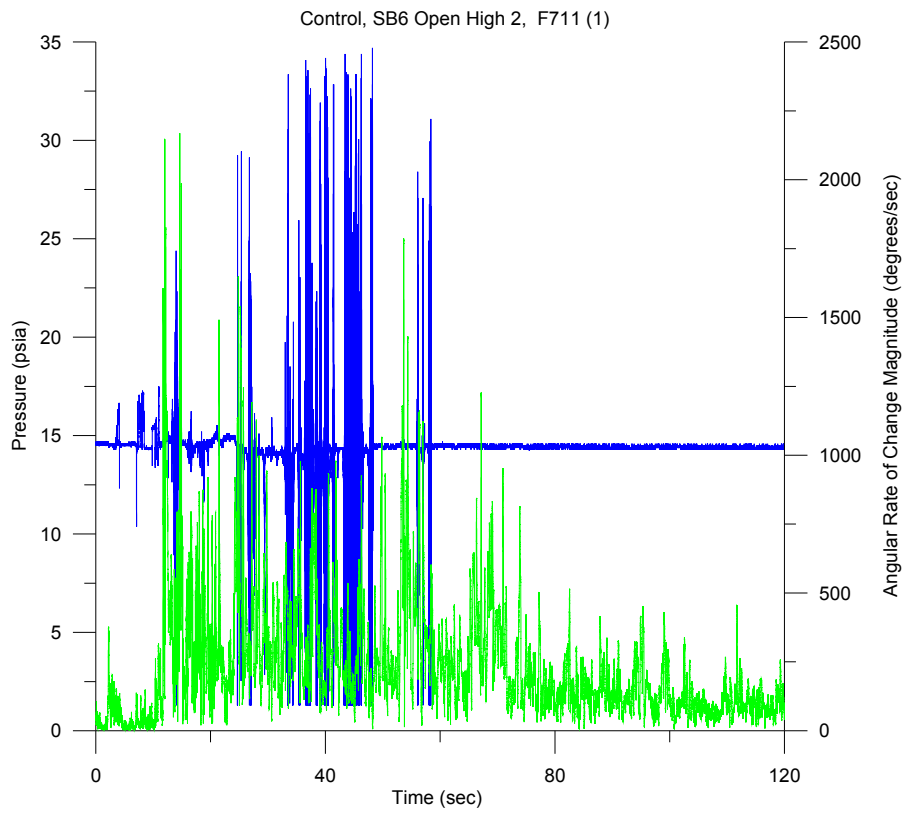
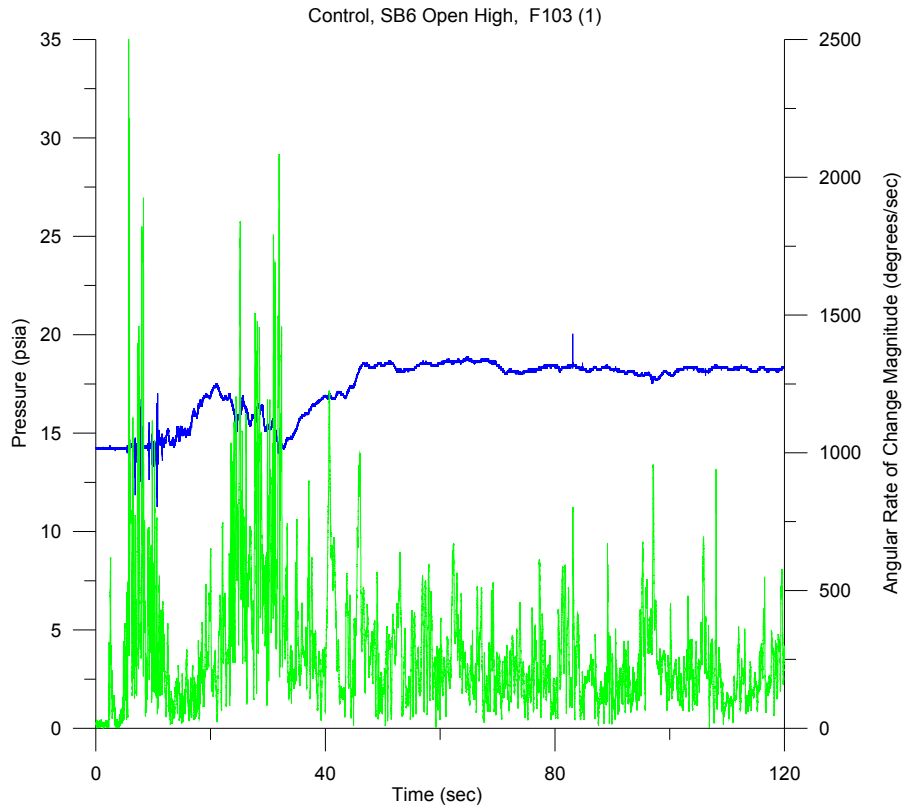


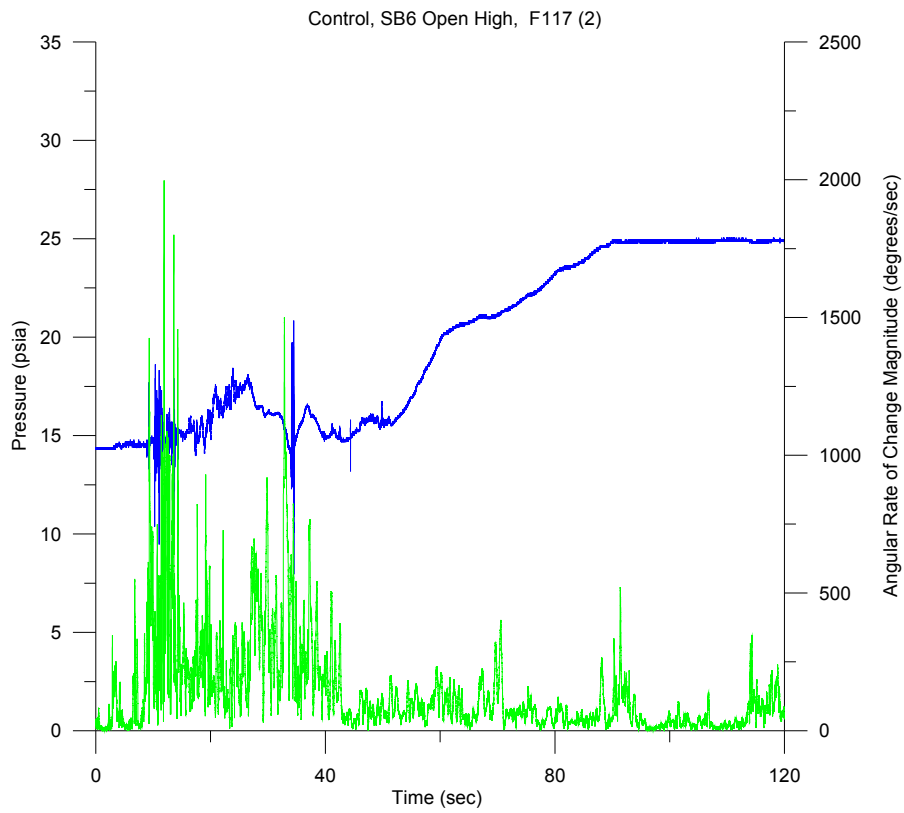
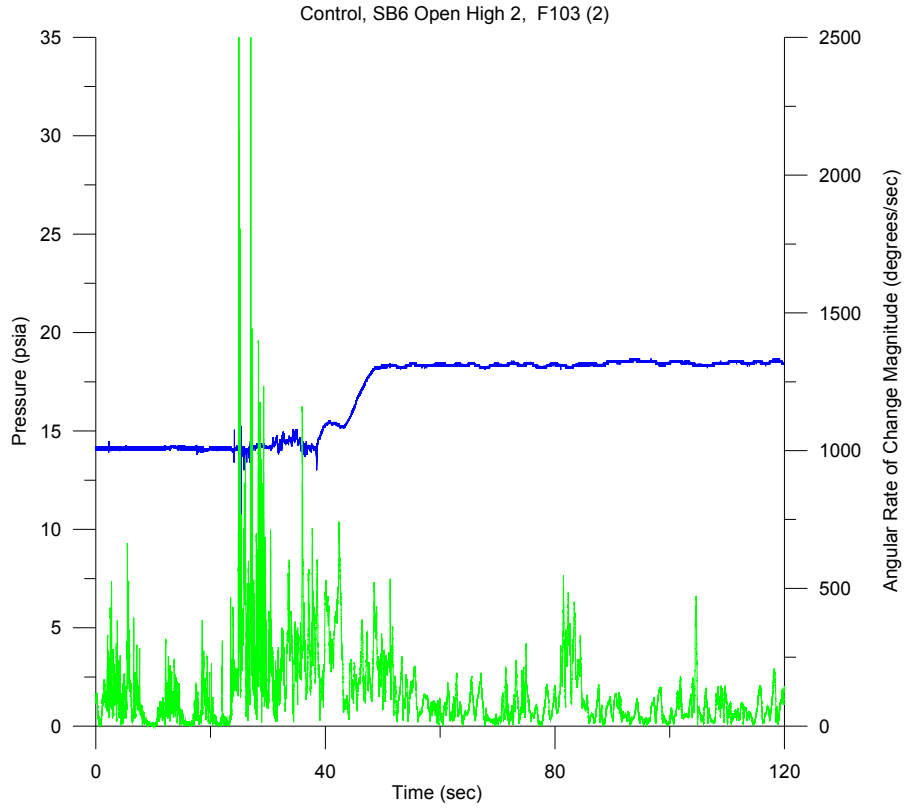


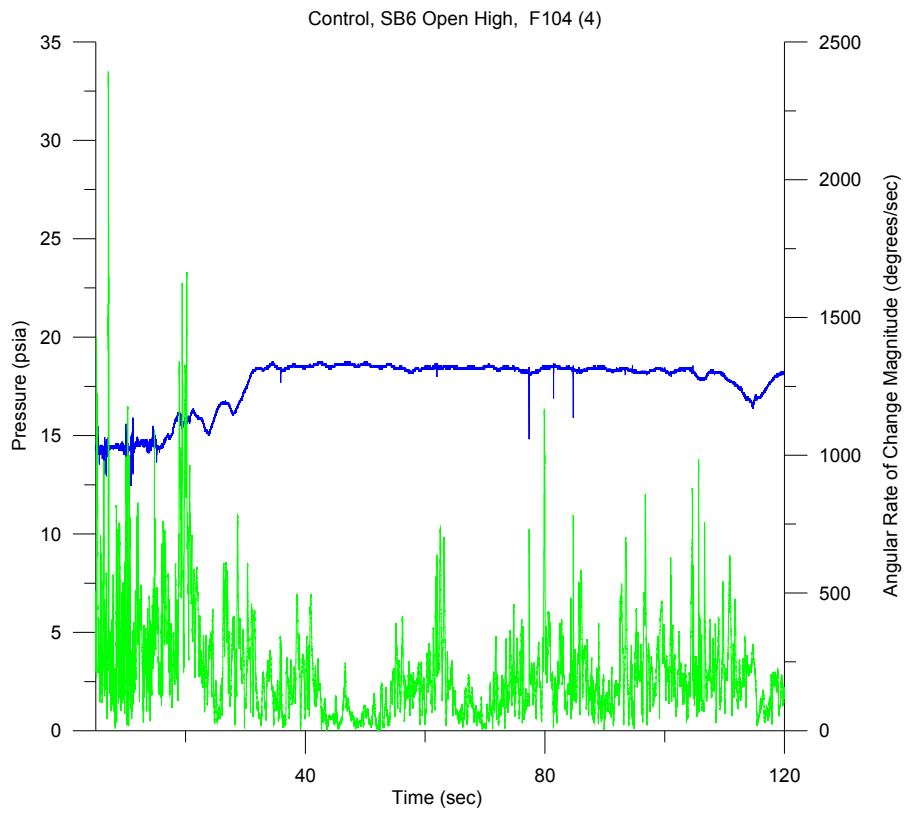
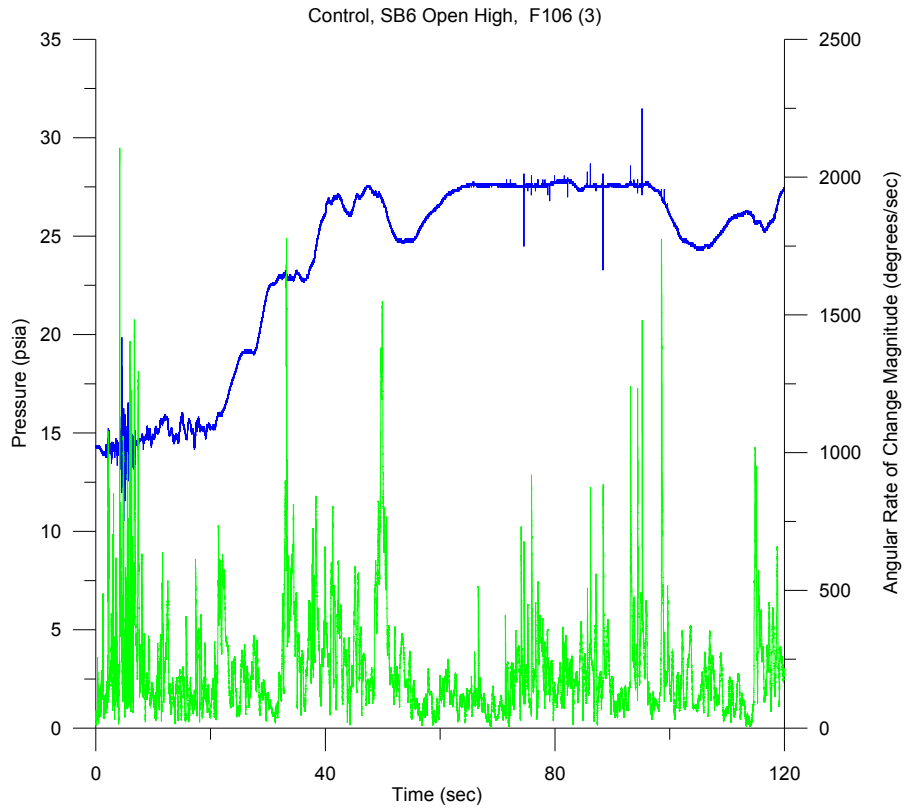


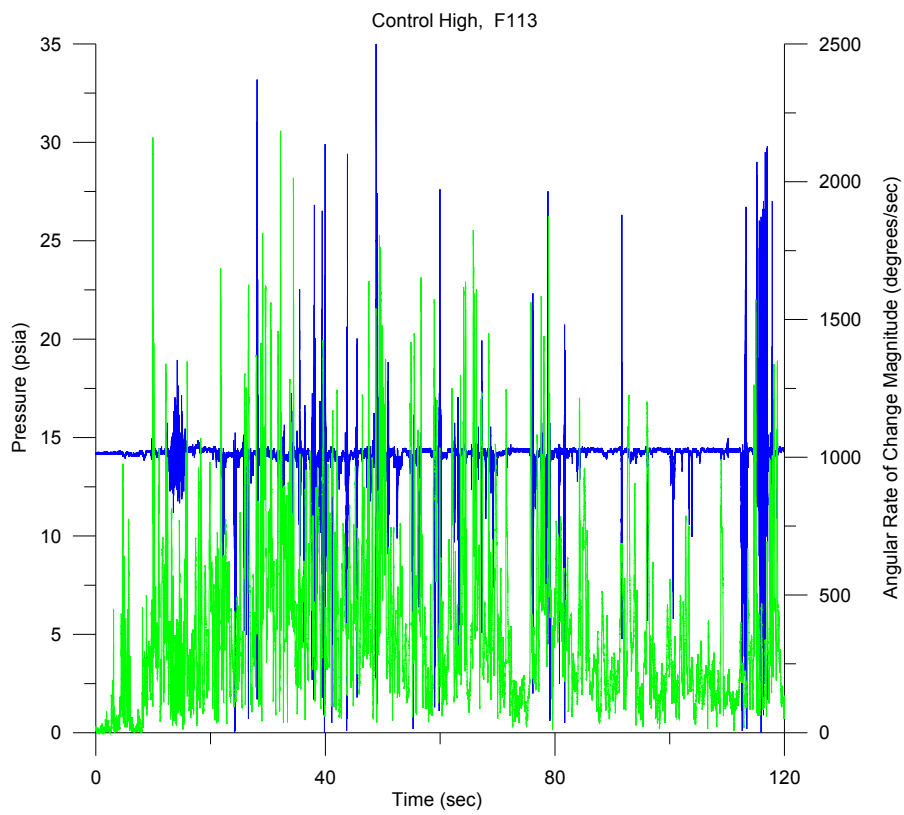
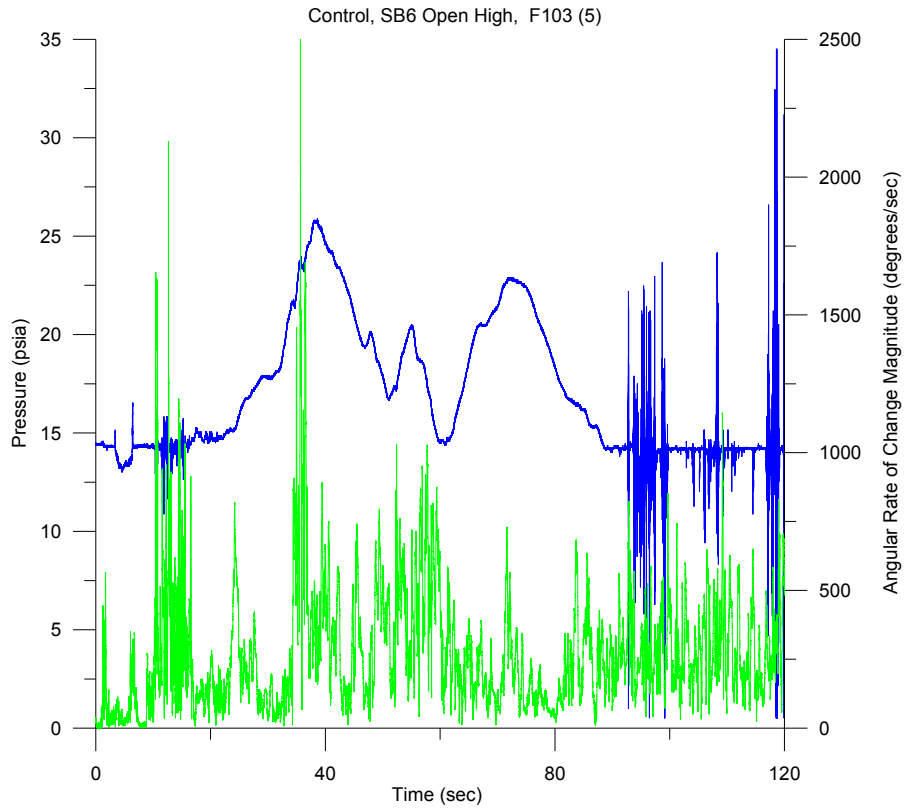
## **Detroit Dam Spillway Evaluation**

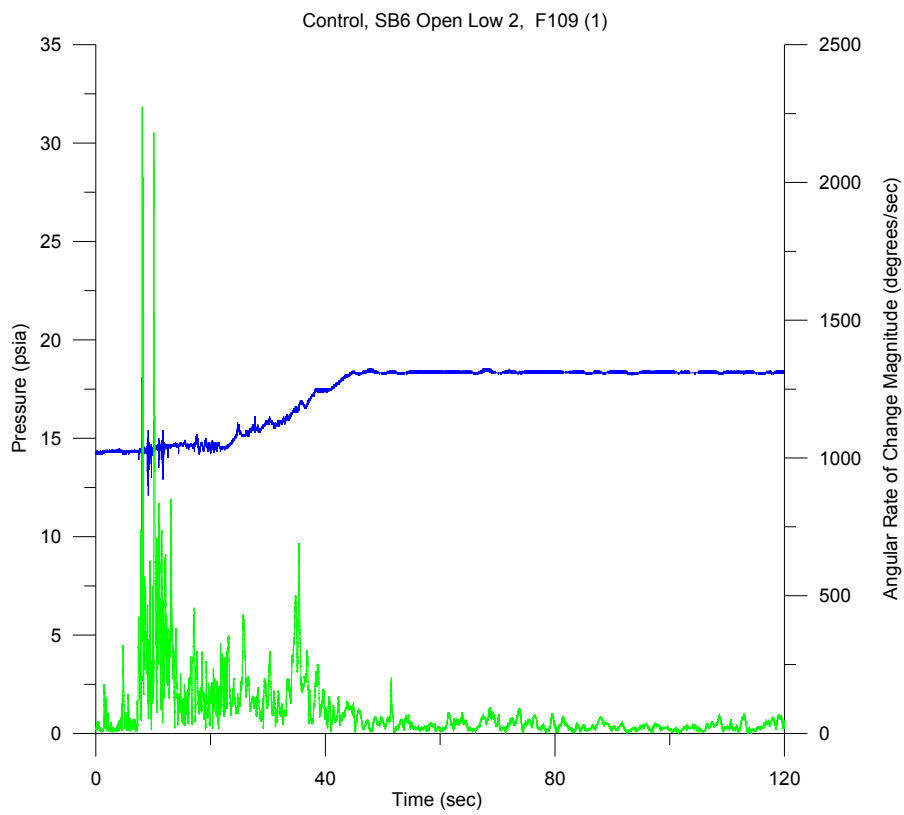
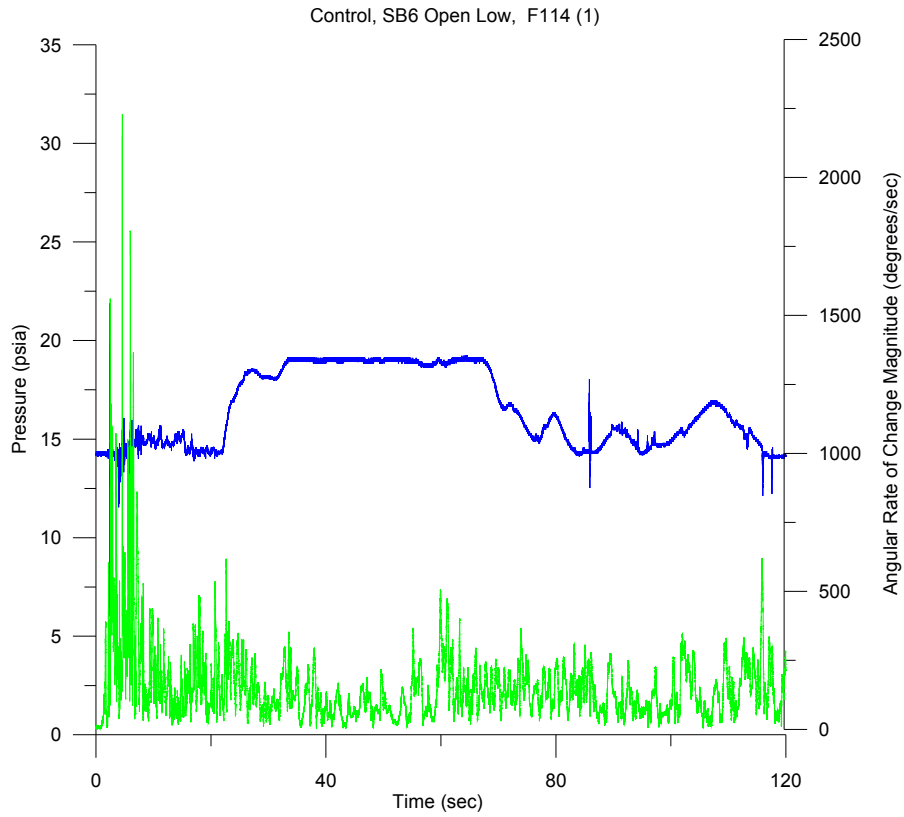
### **Controls**



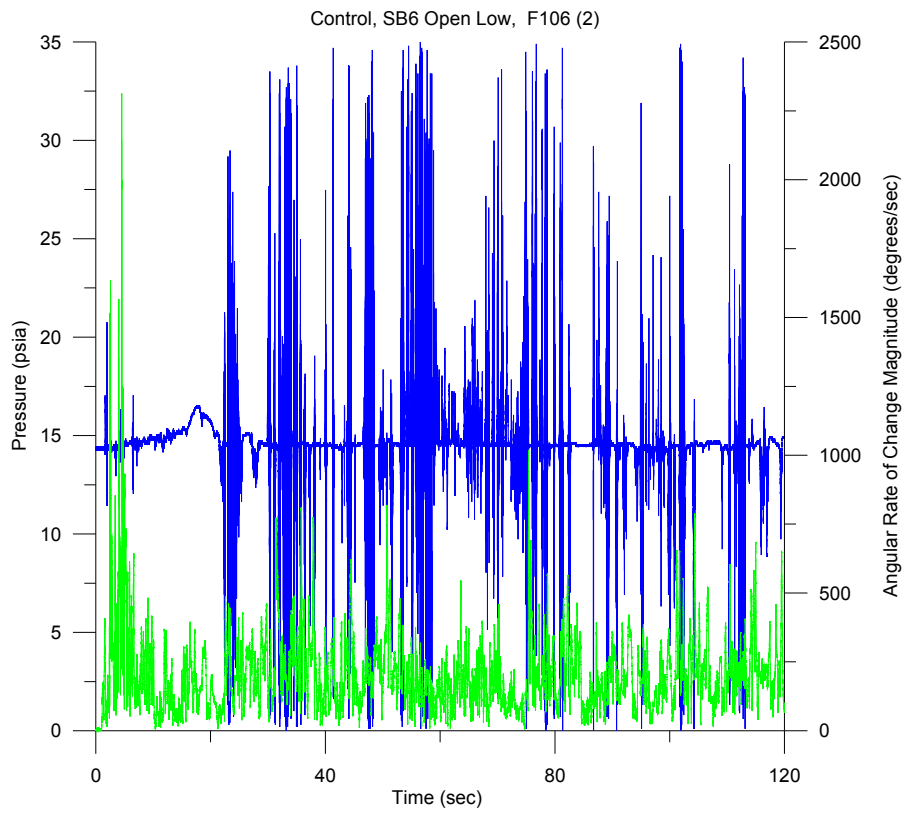
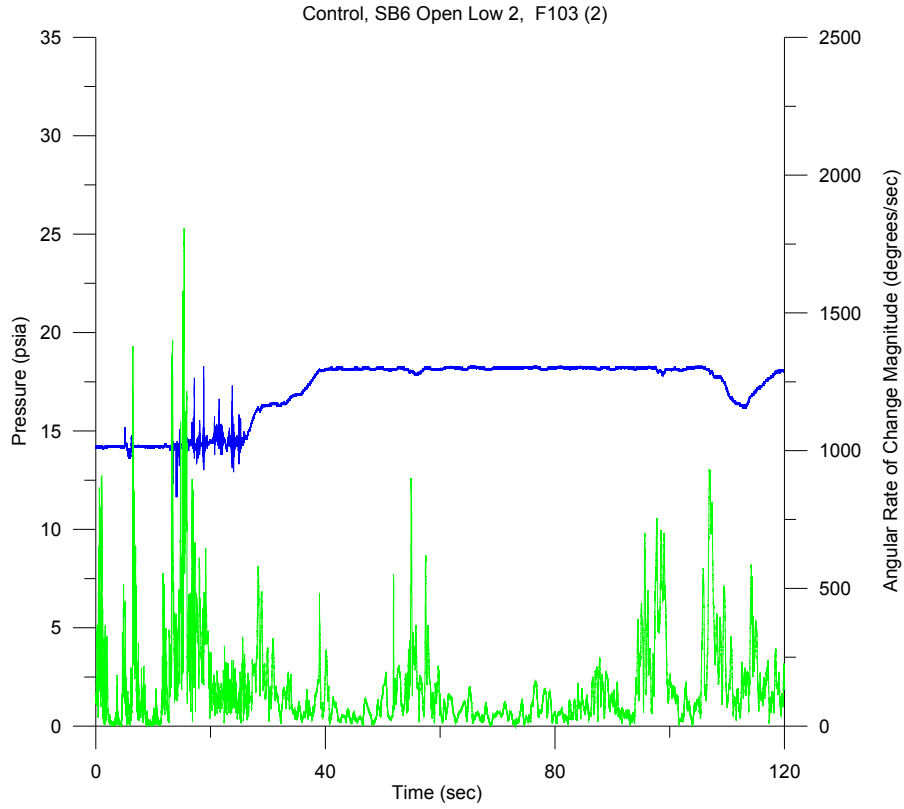


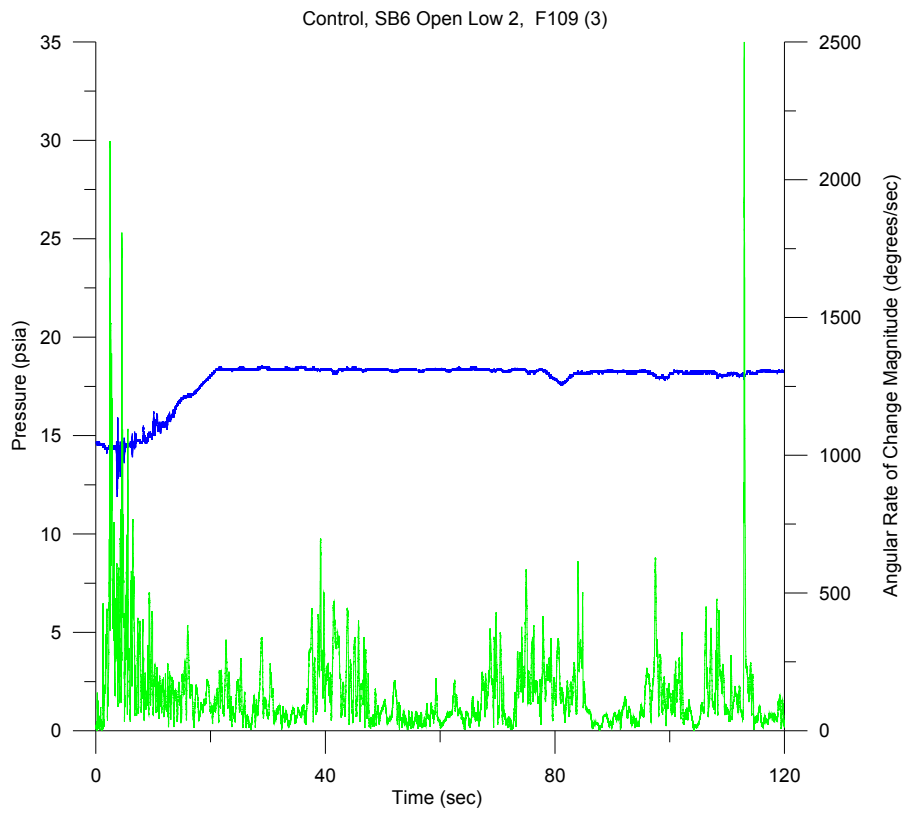
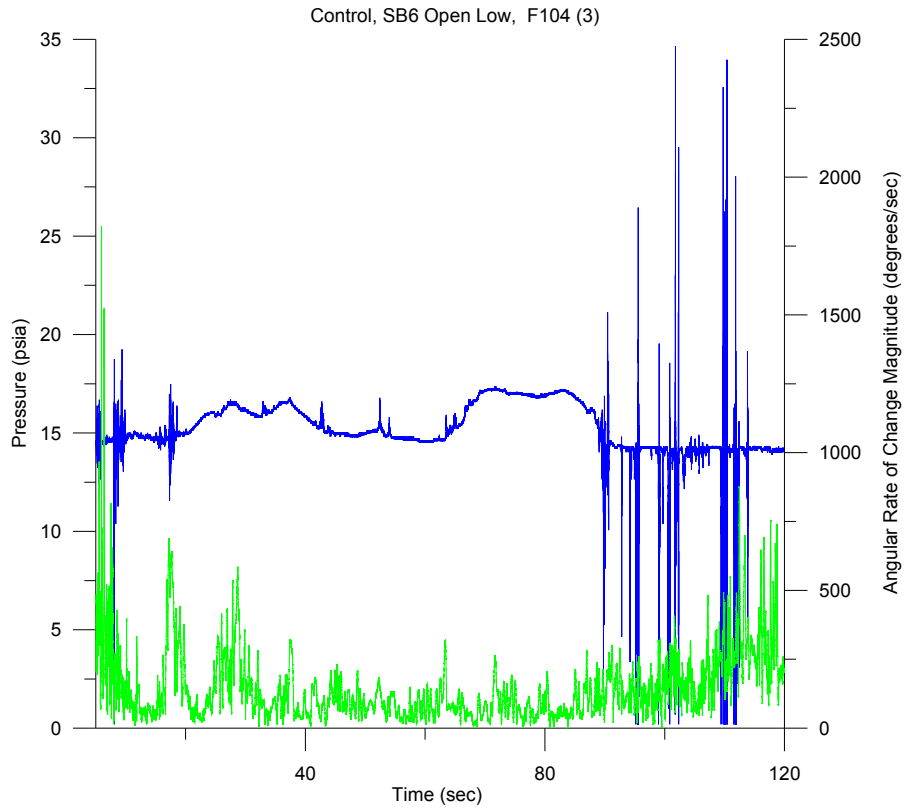


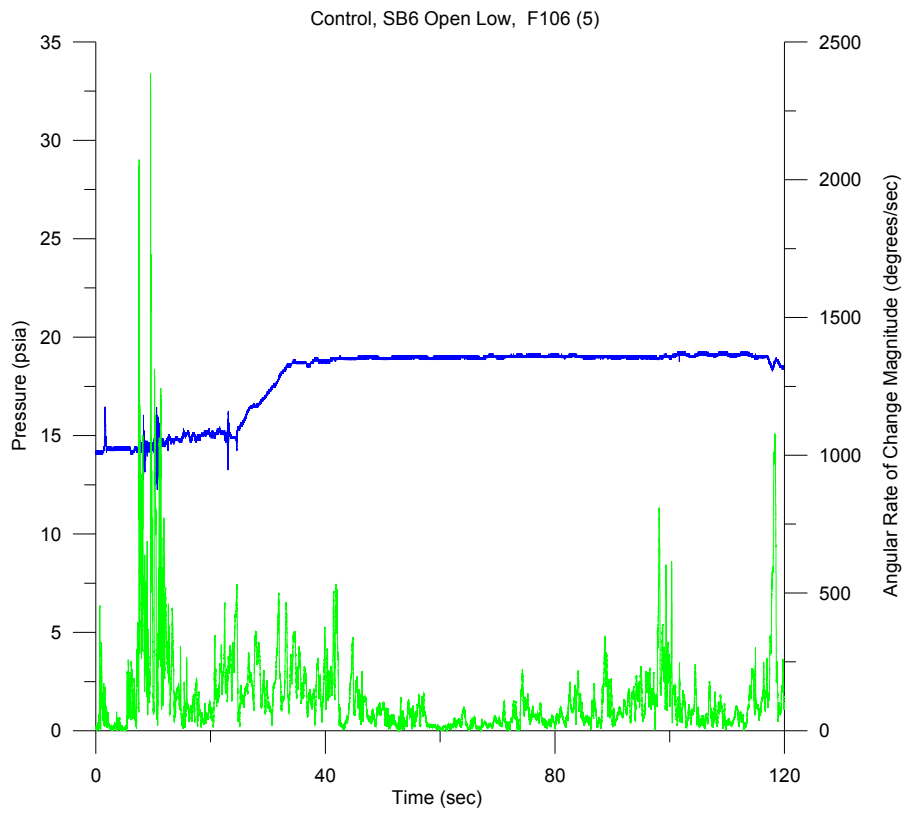
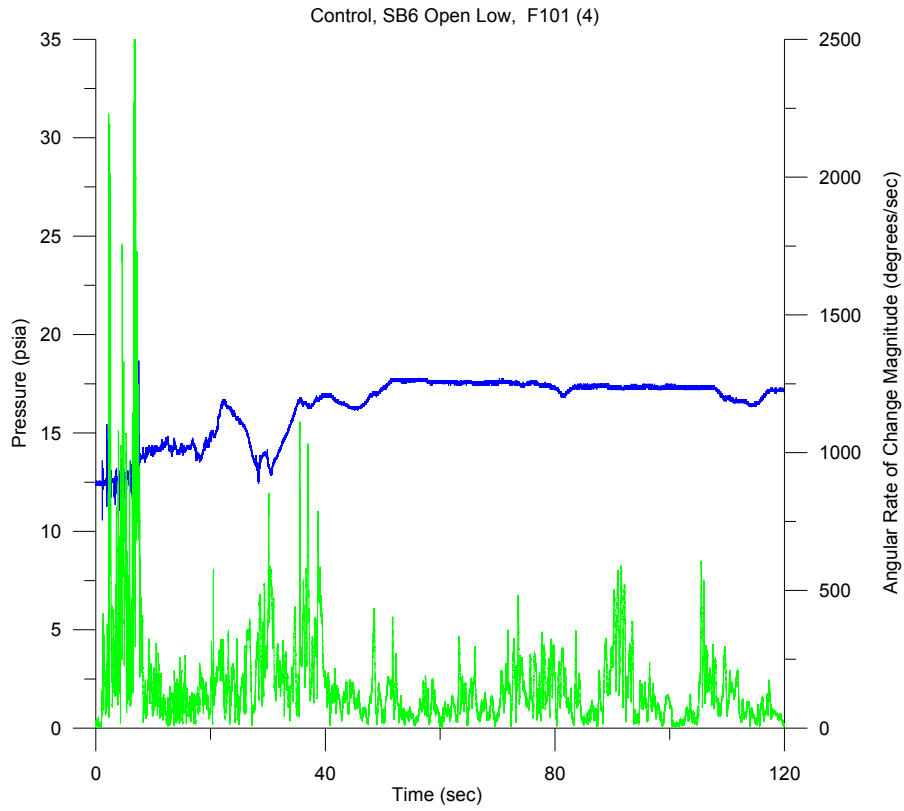


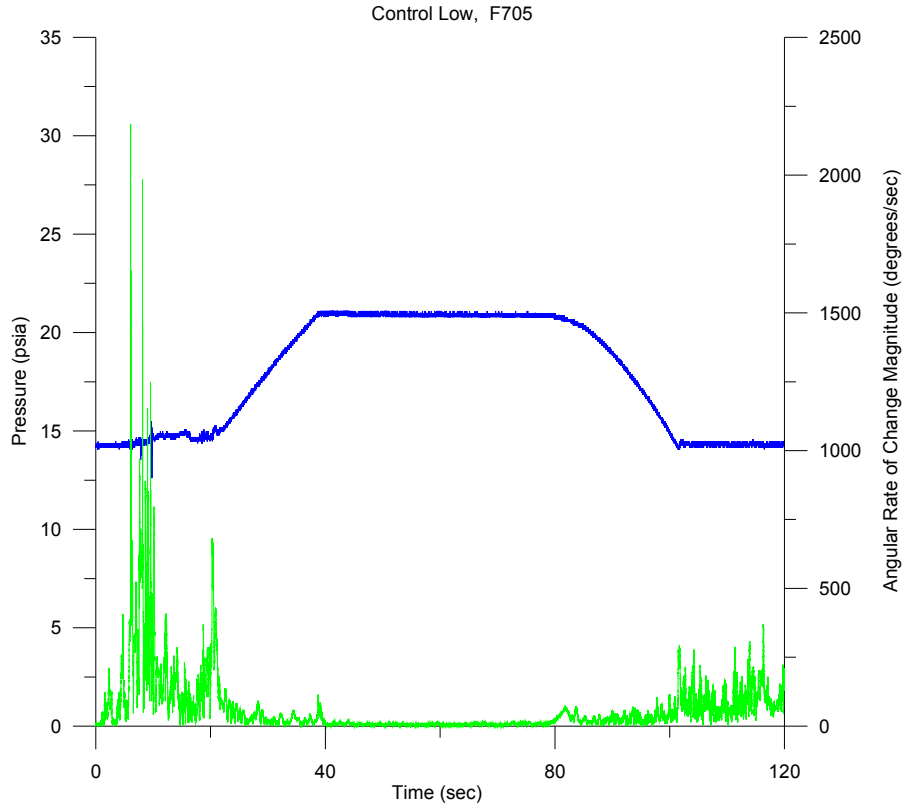




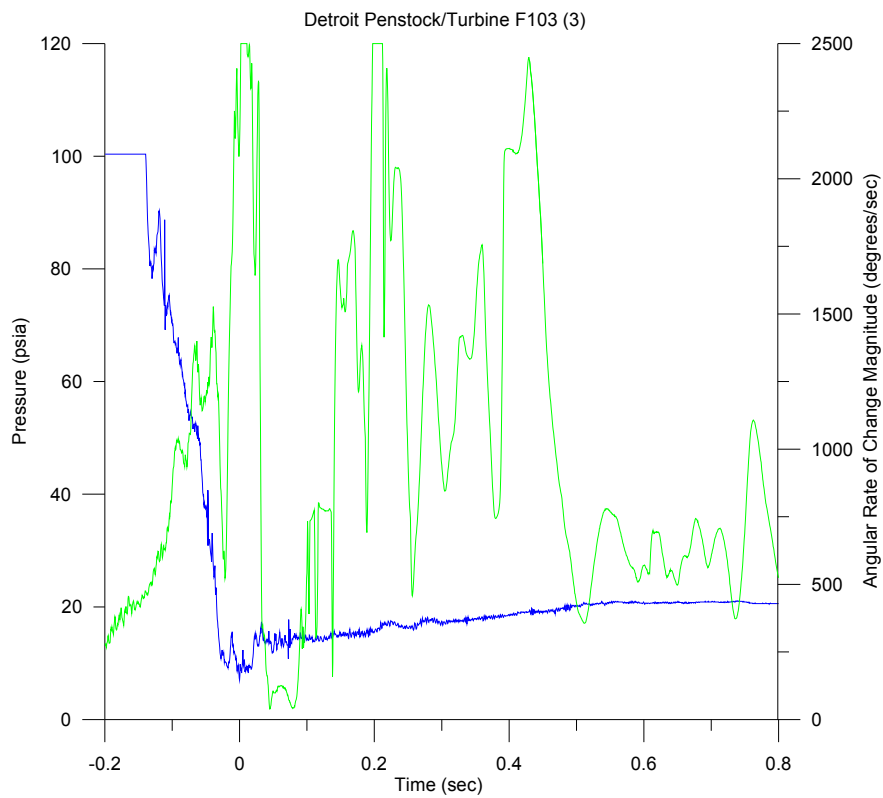
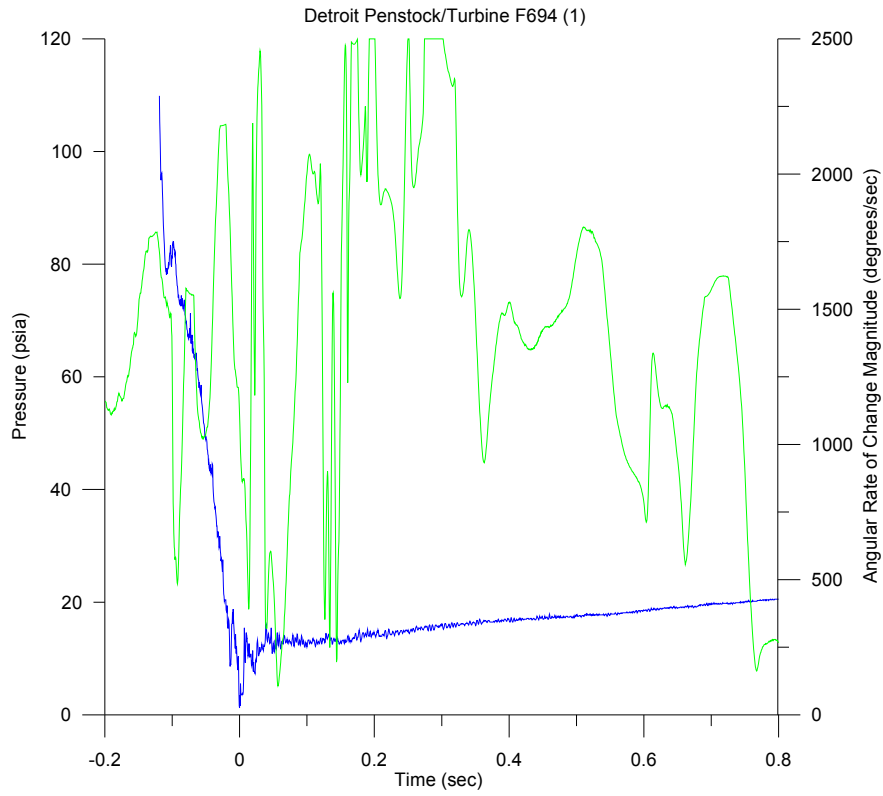


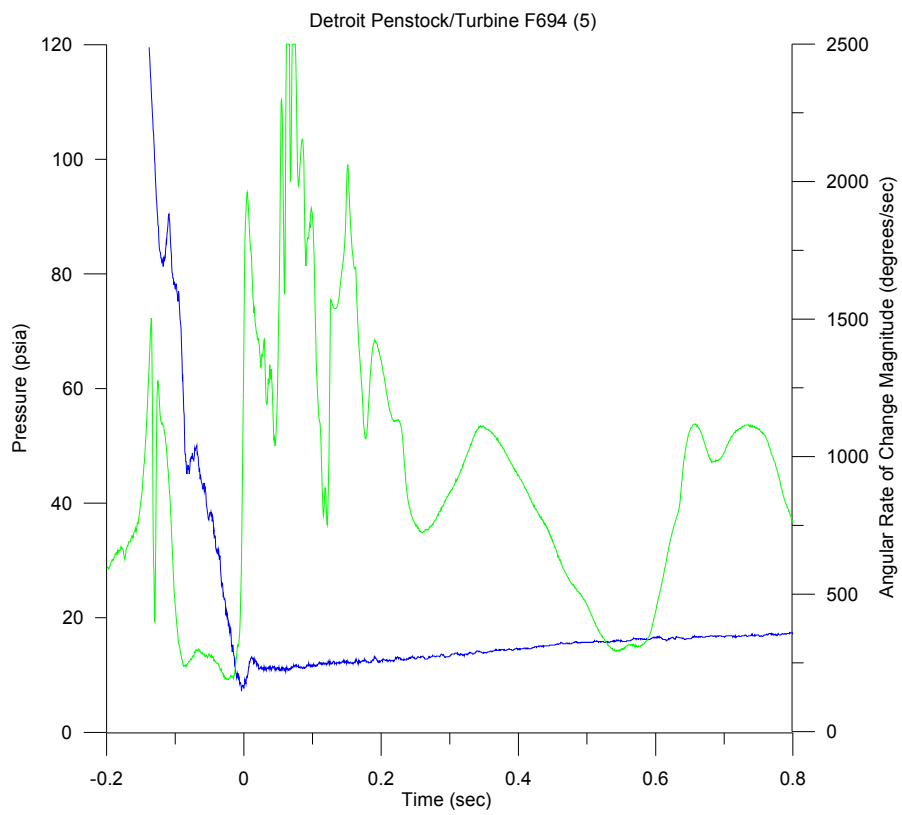
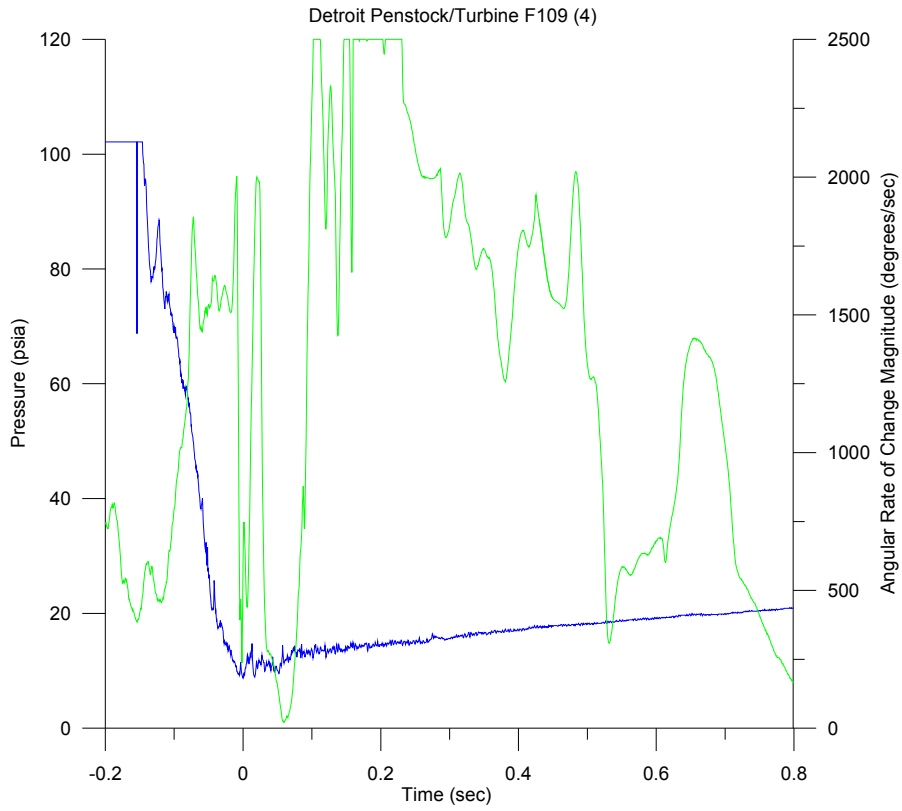


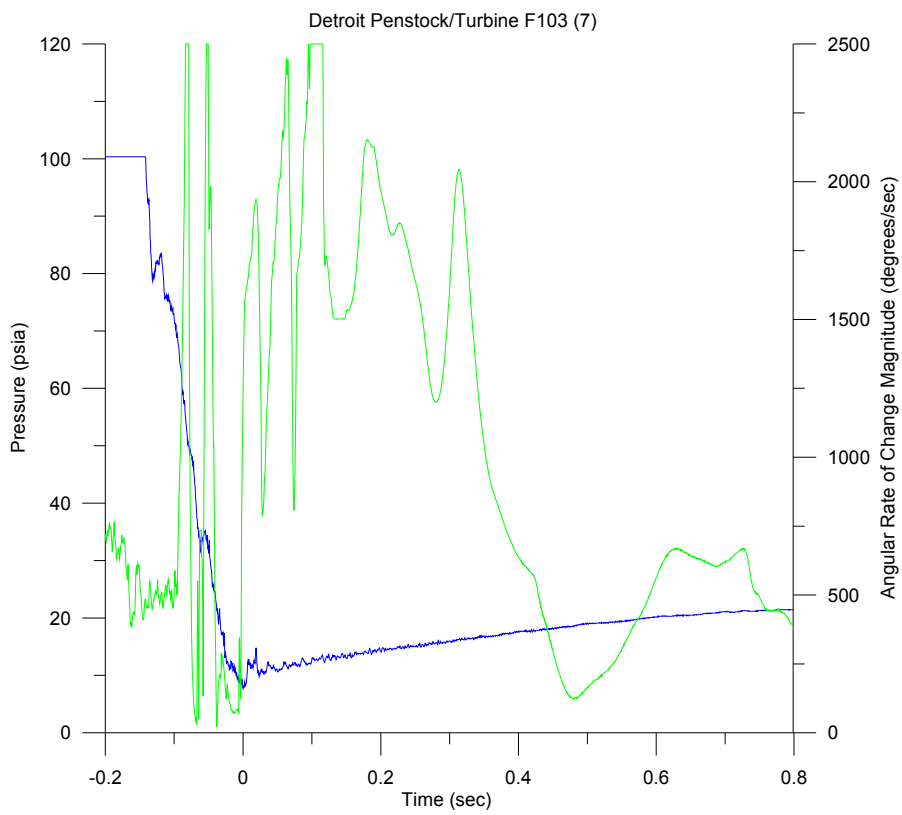
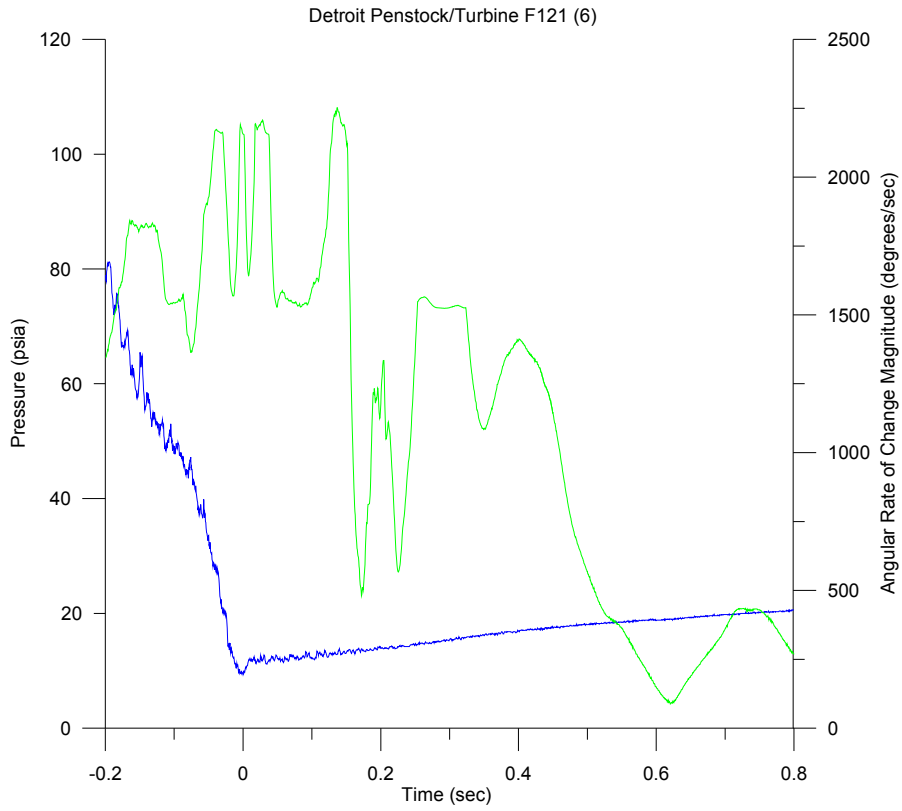




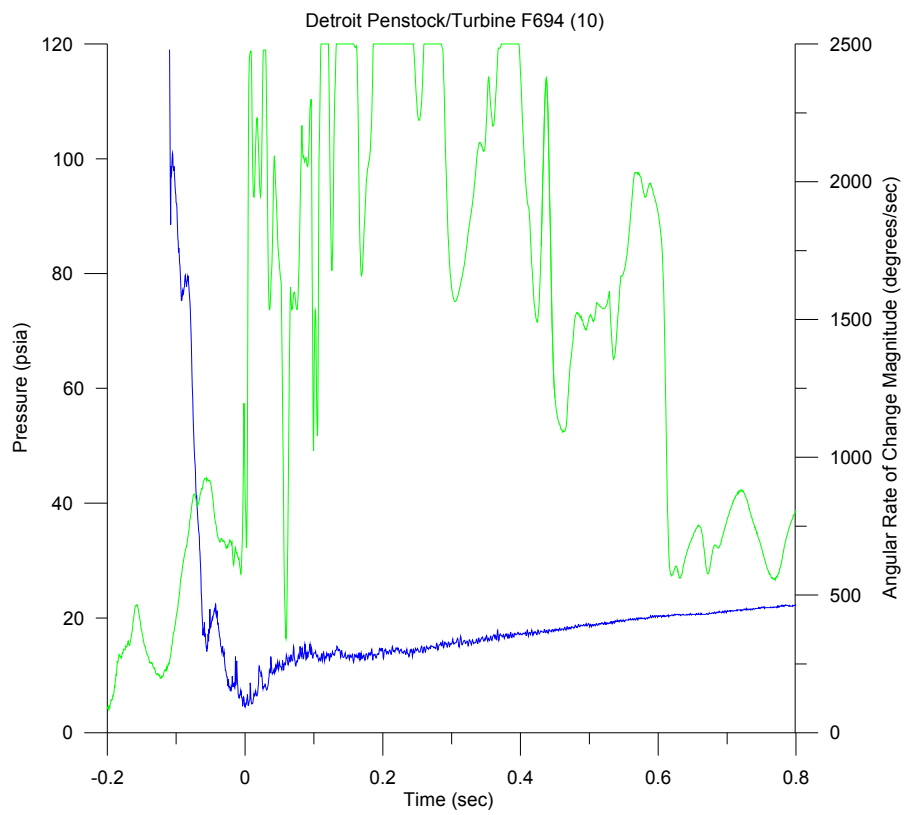
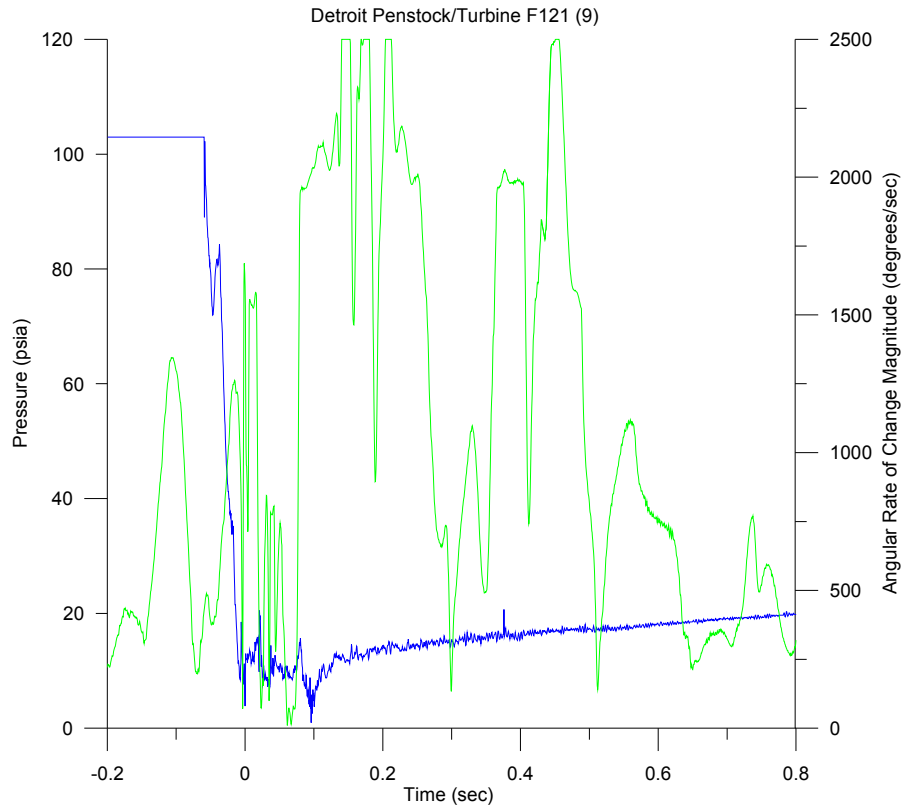
## **Detroit Dam Turbine**

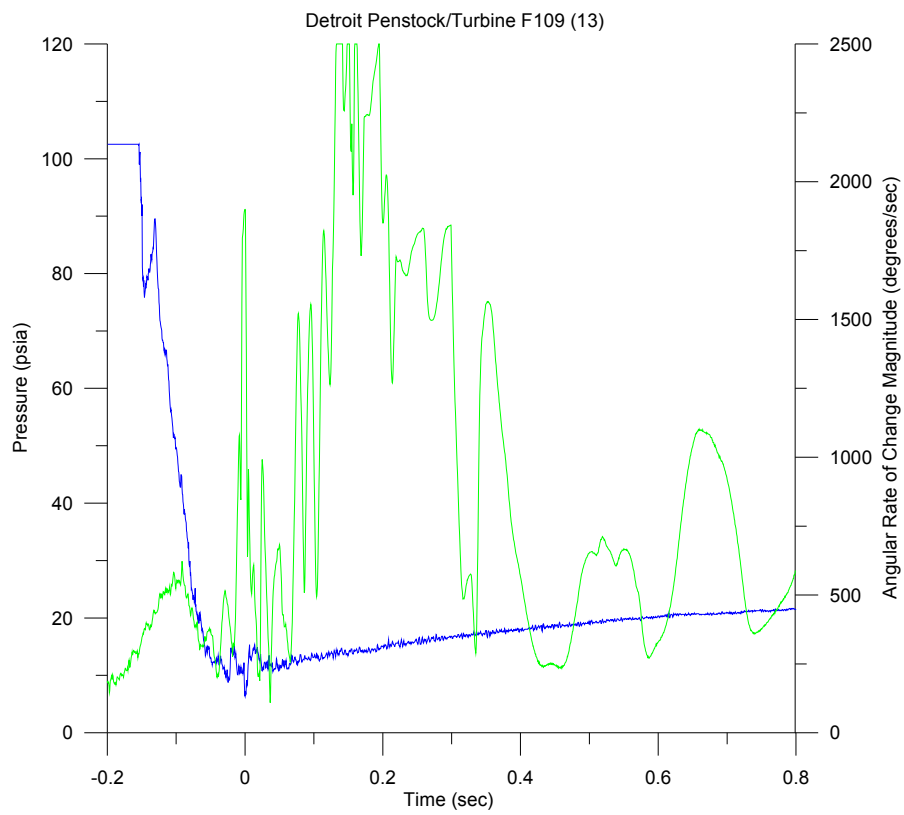
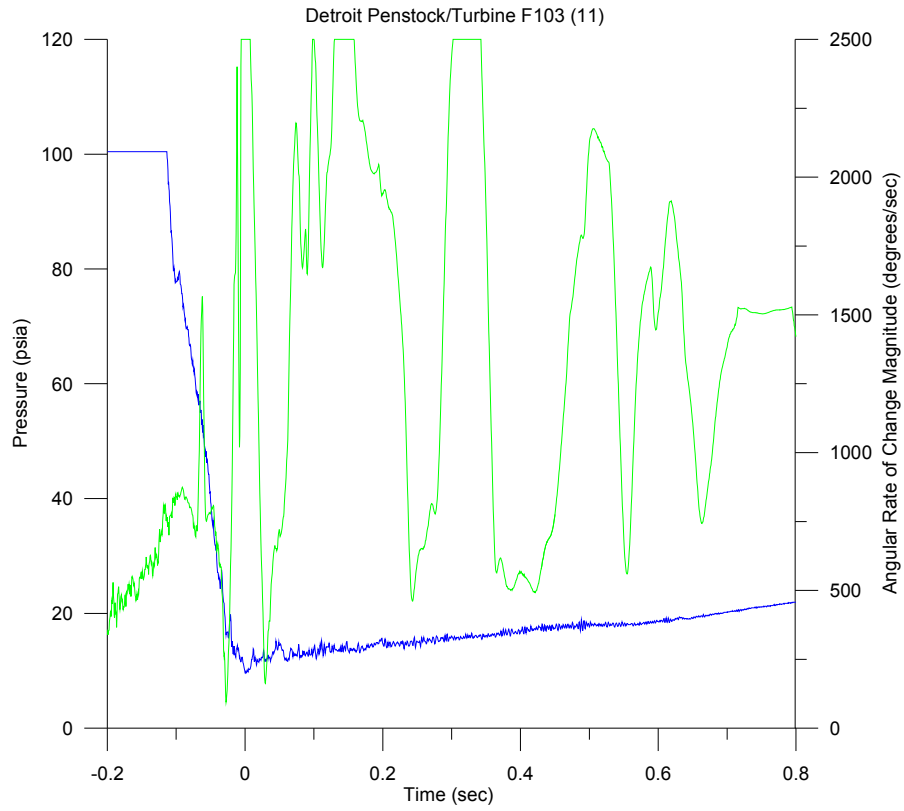


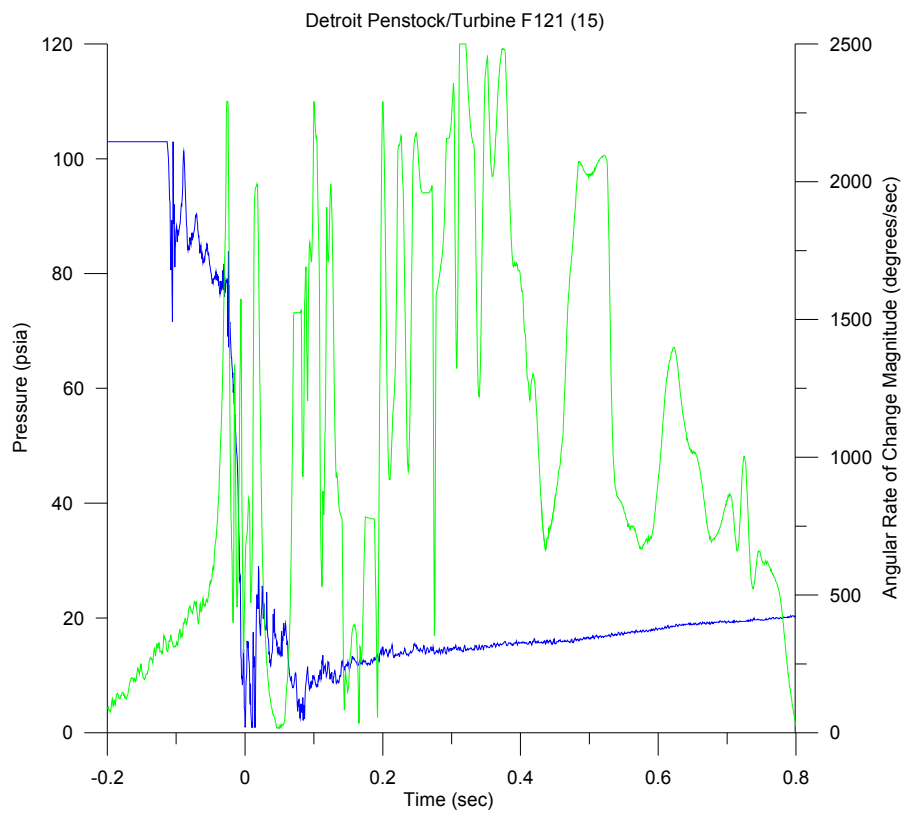
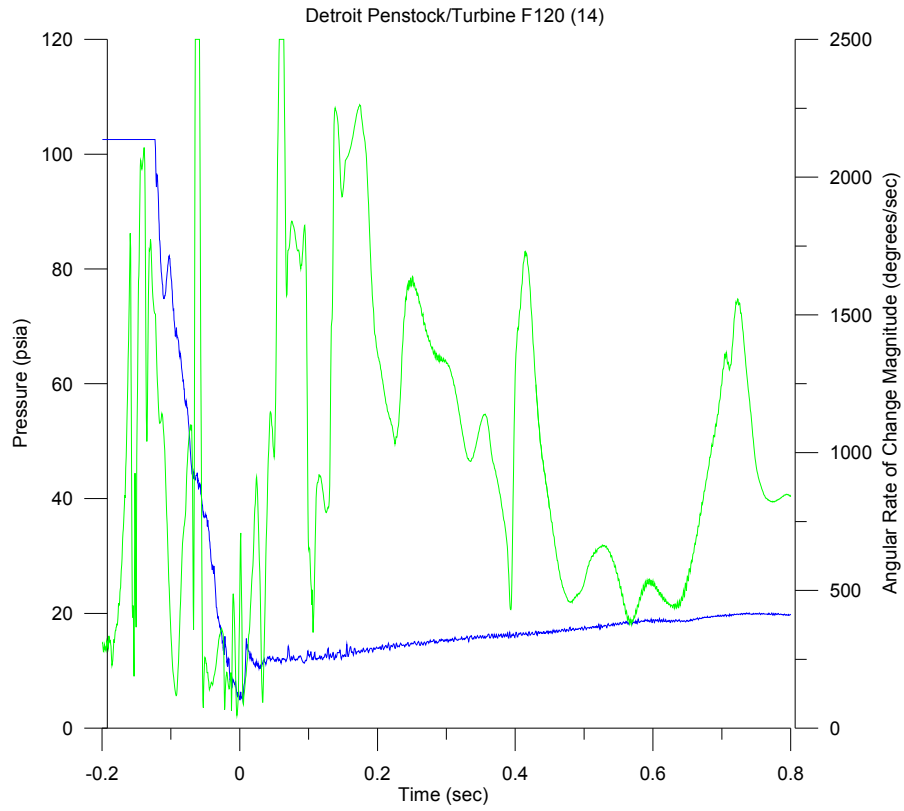


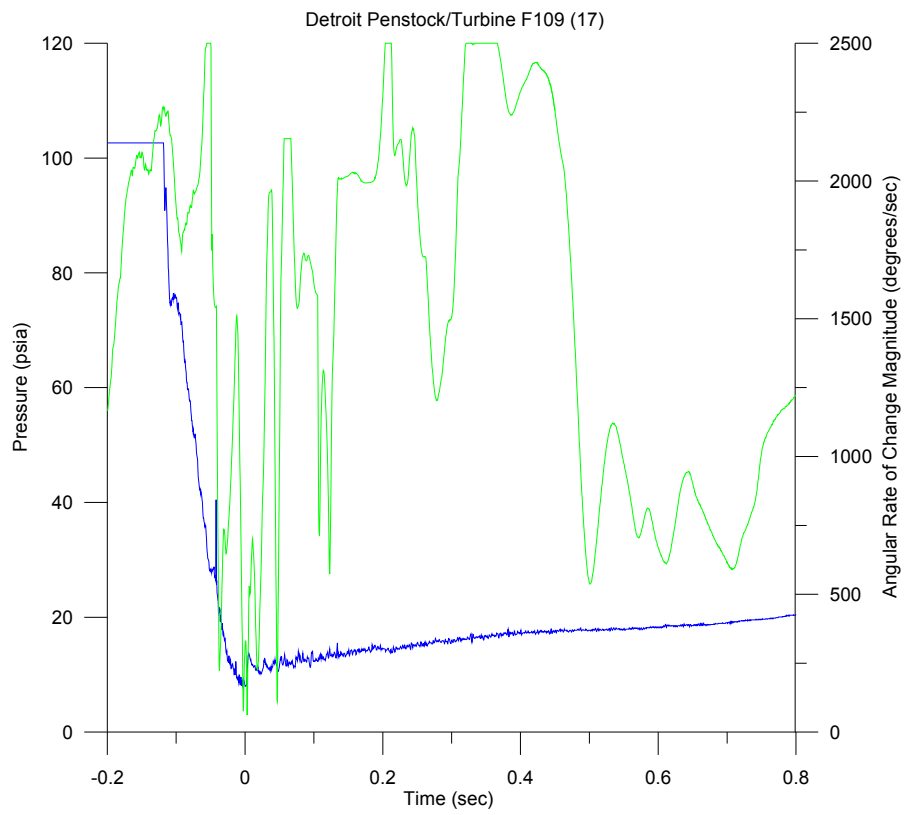
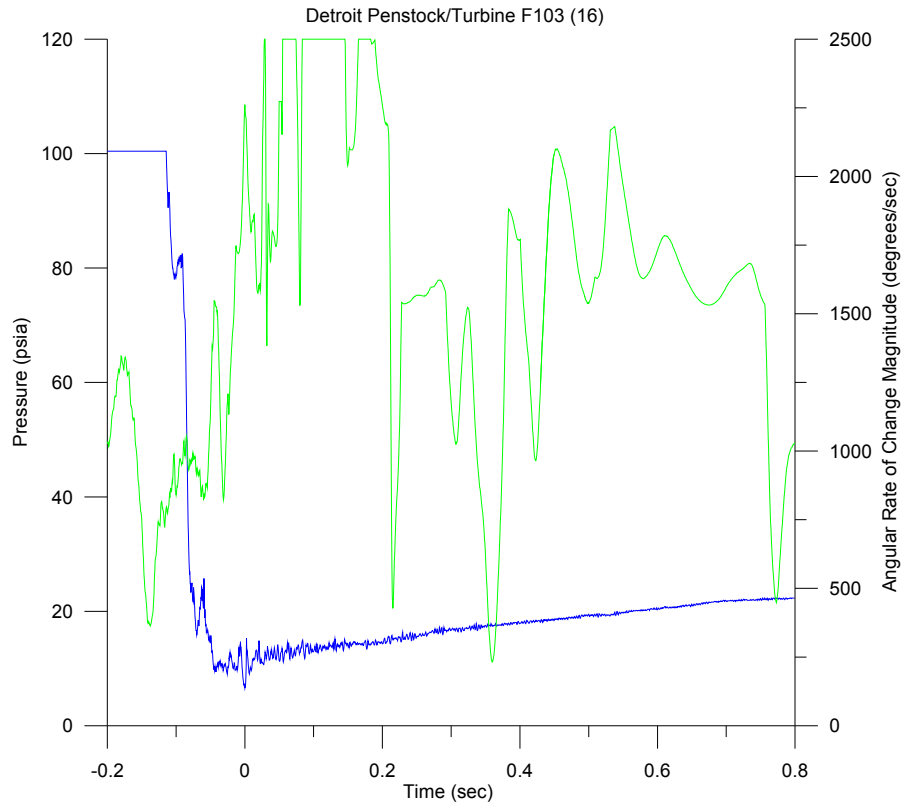


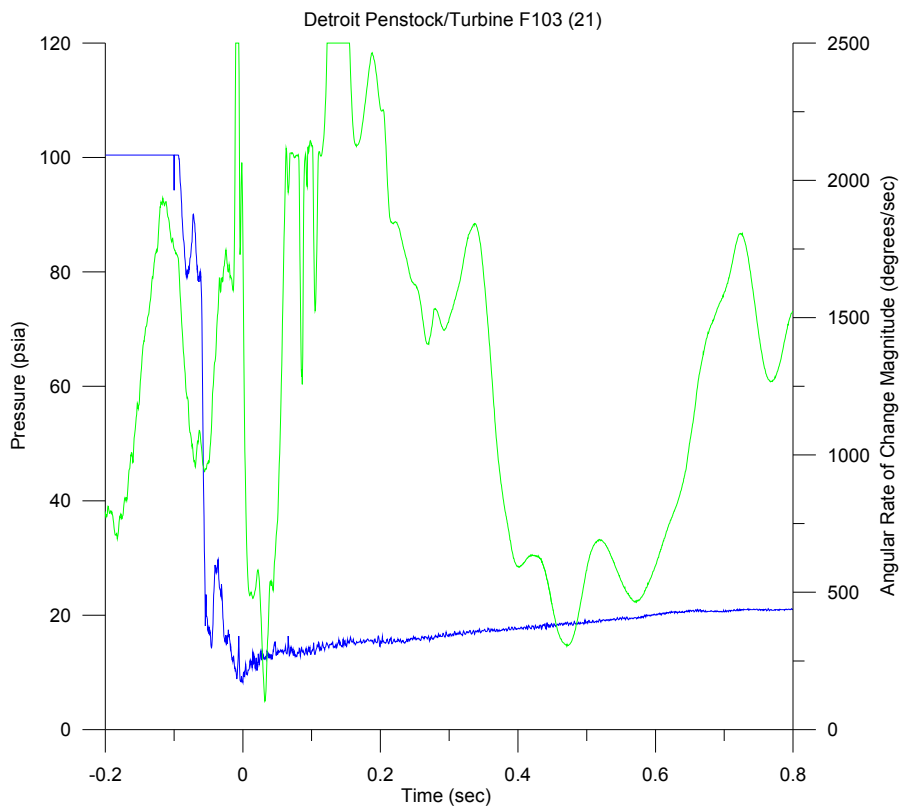
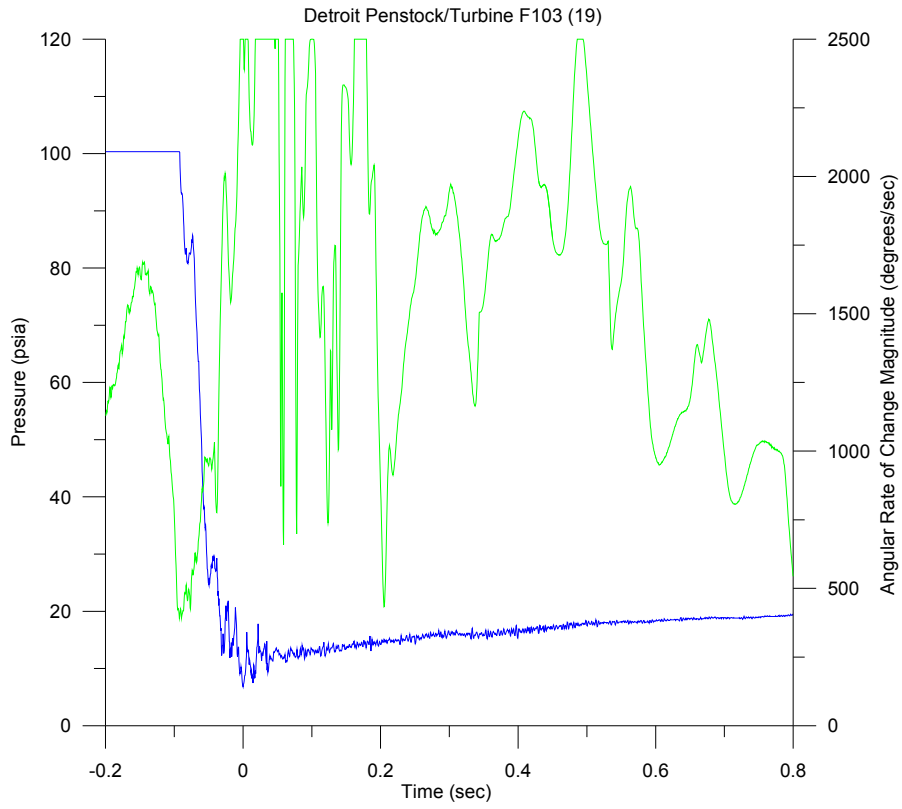


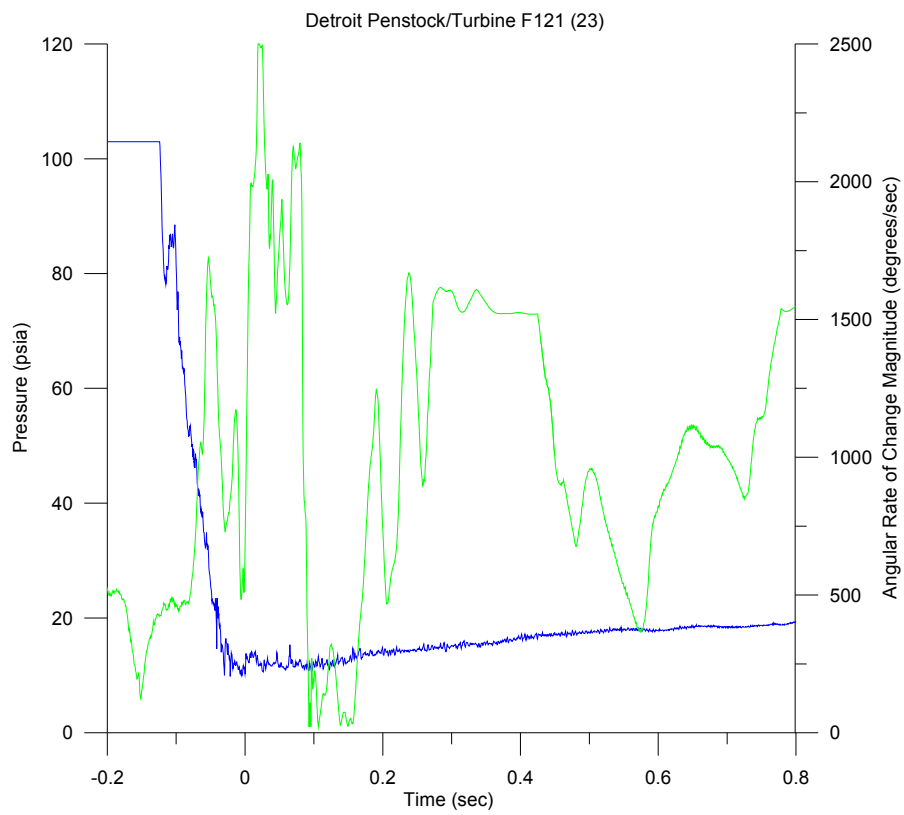
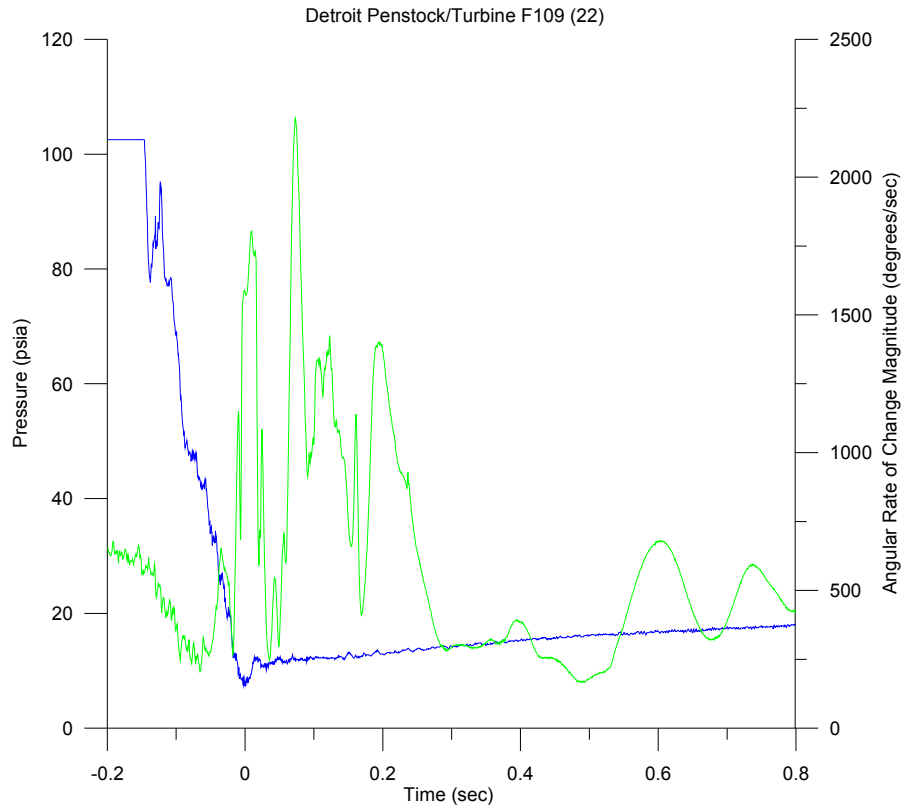


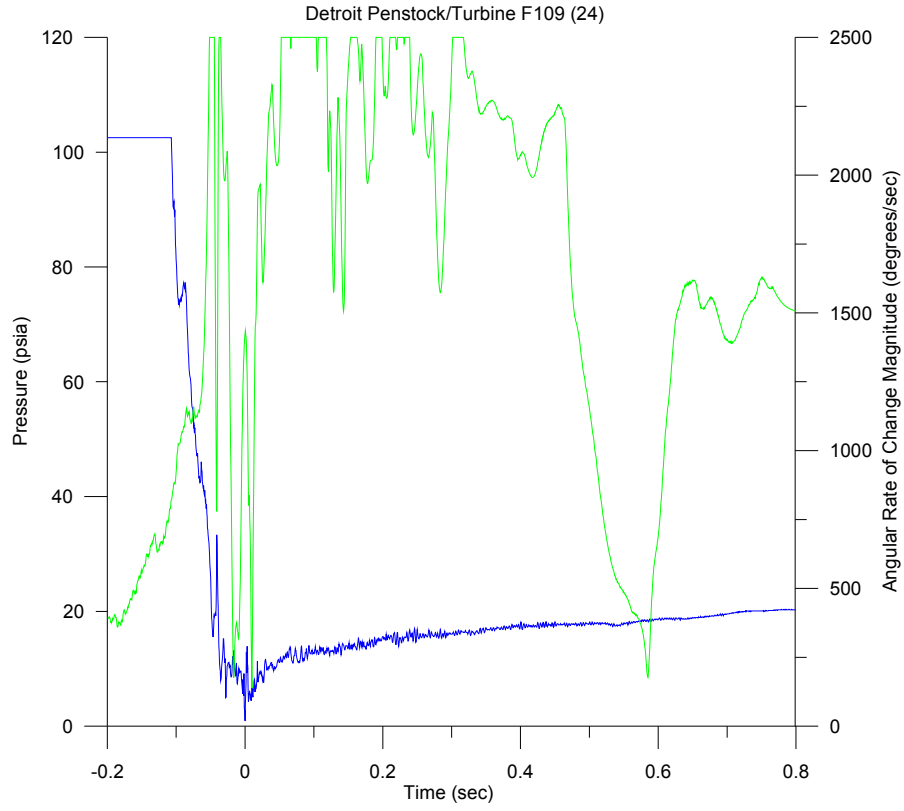








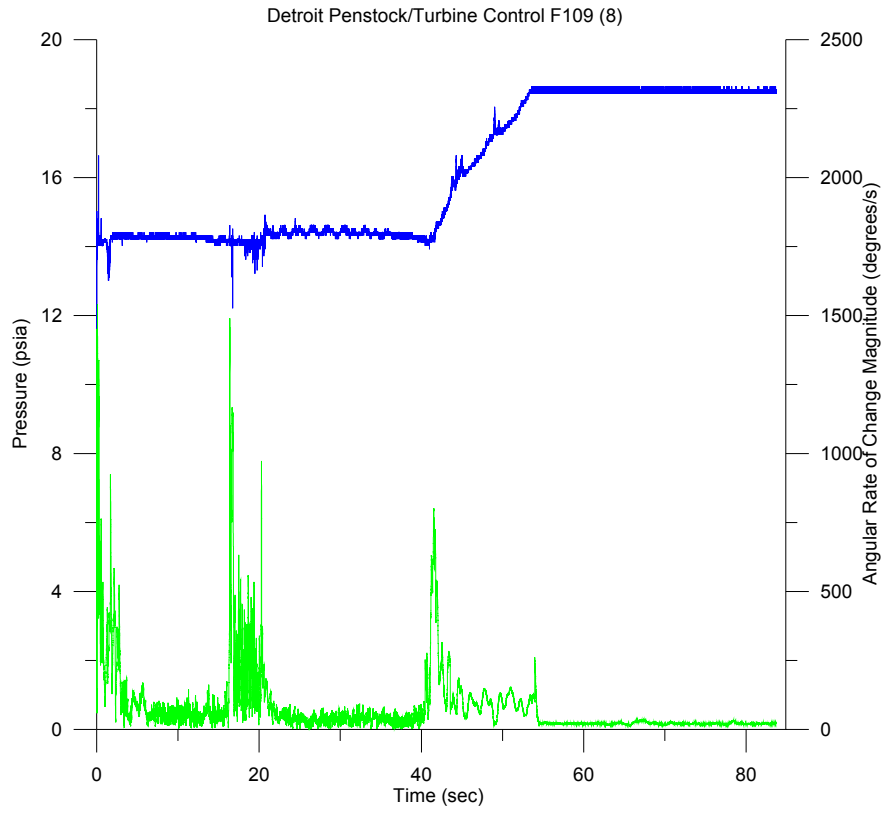




# **Detroit Dam Turbine**

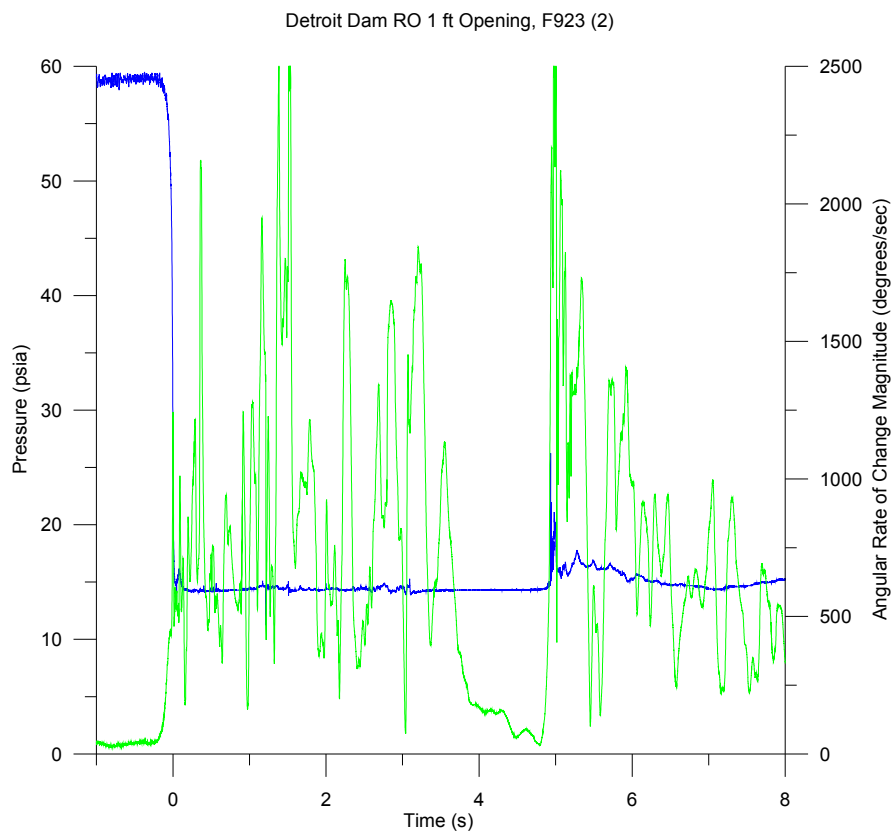
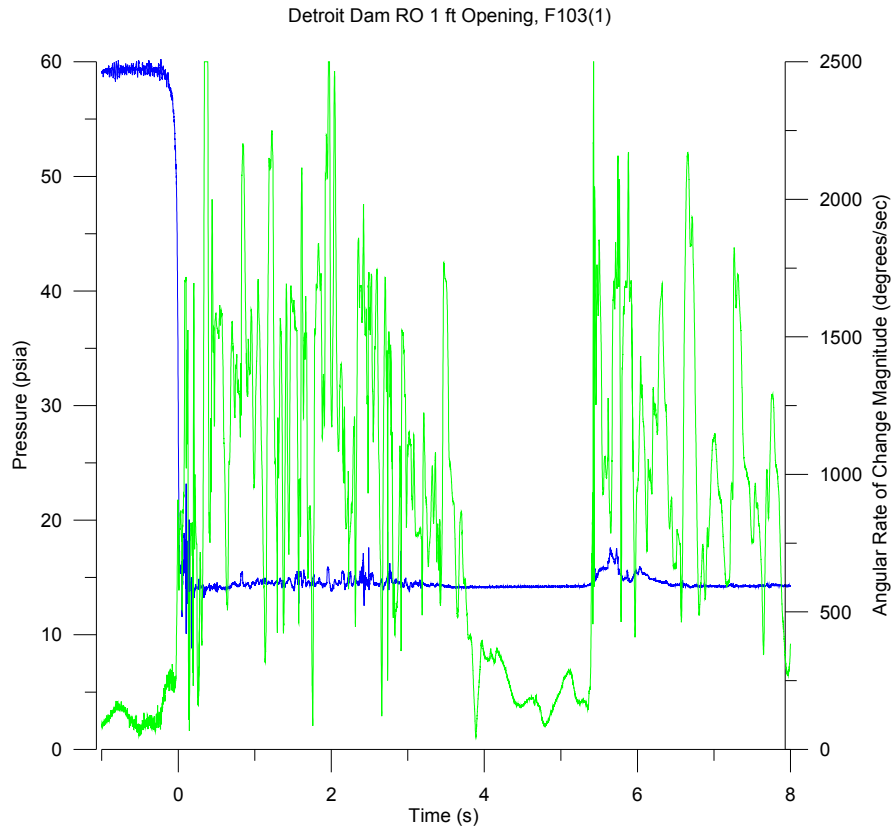
## **Control**

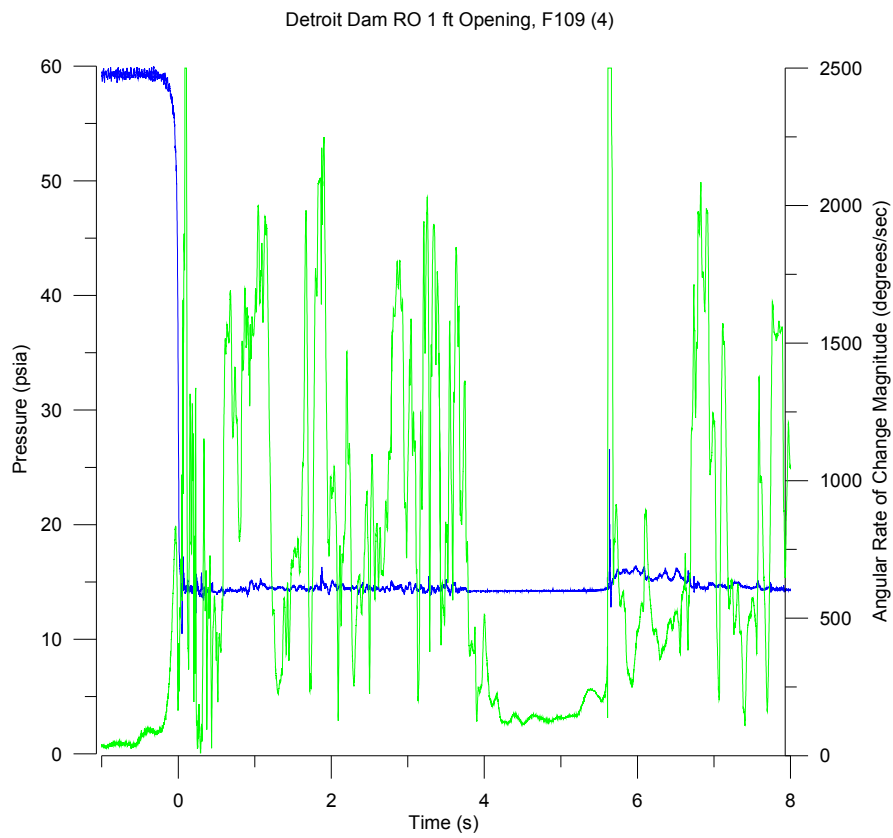
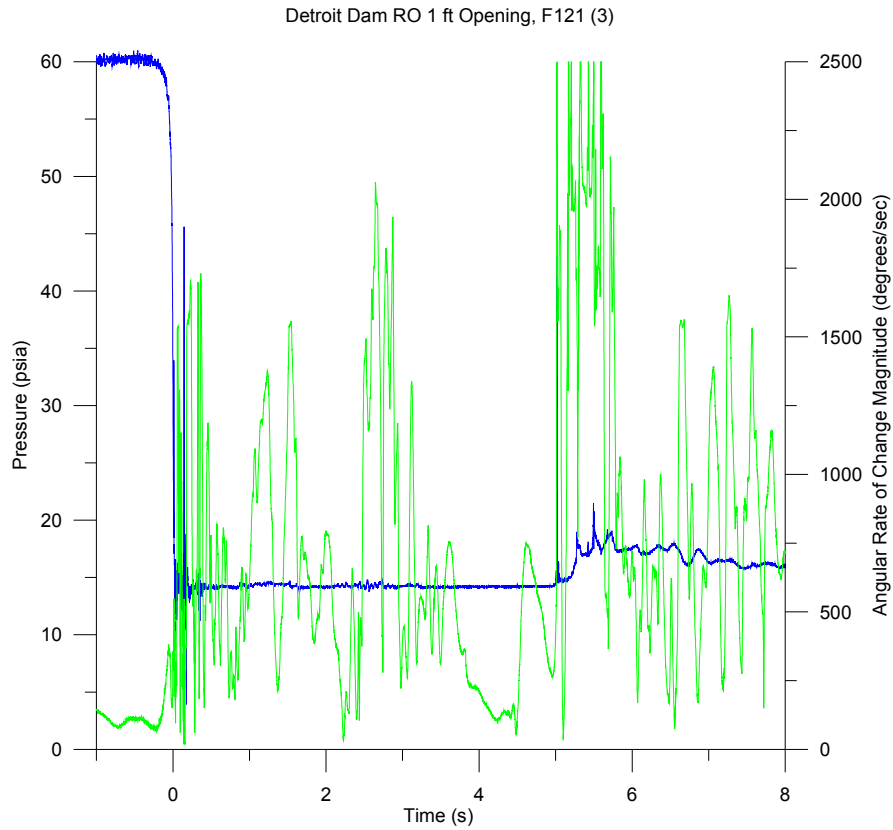


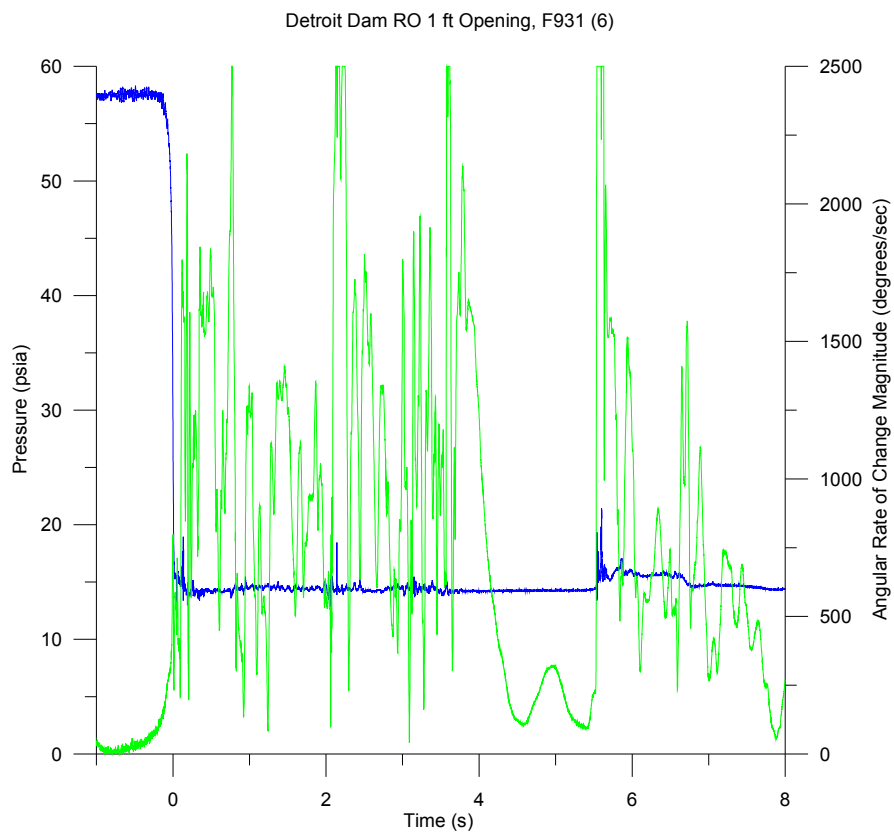
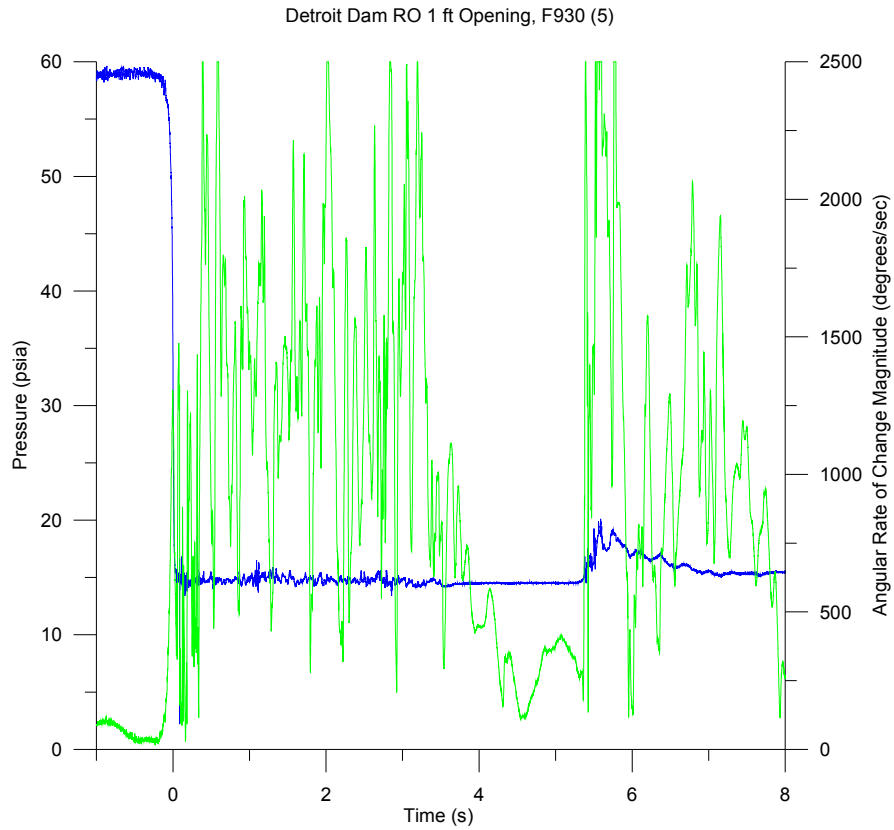


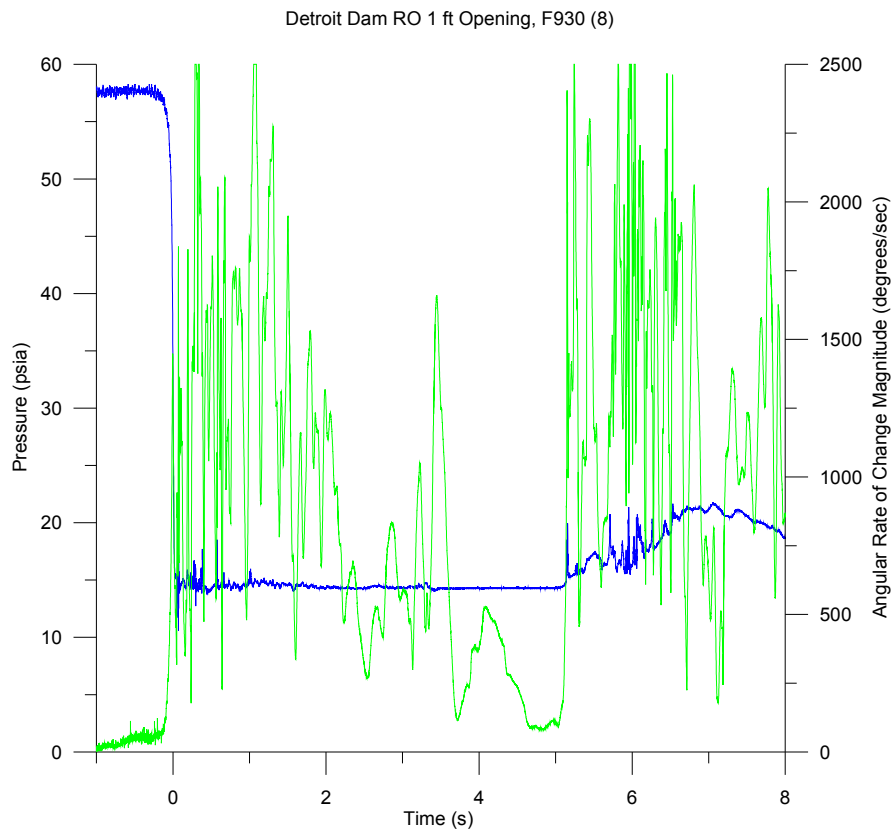
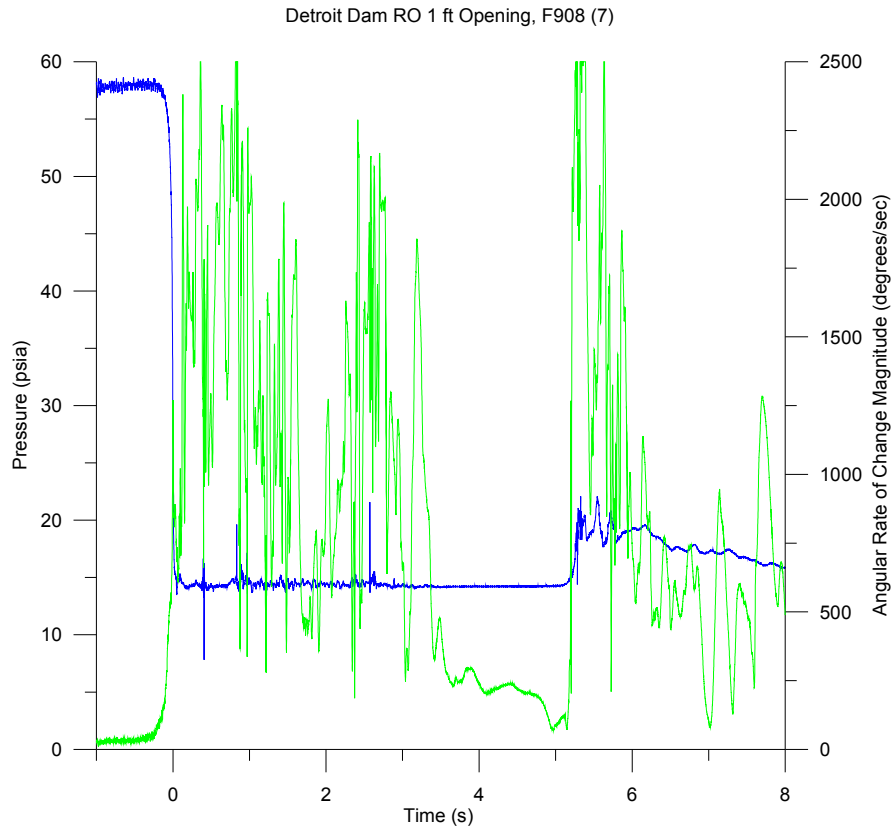
## **Detroit Dam Regulating Outlet**

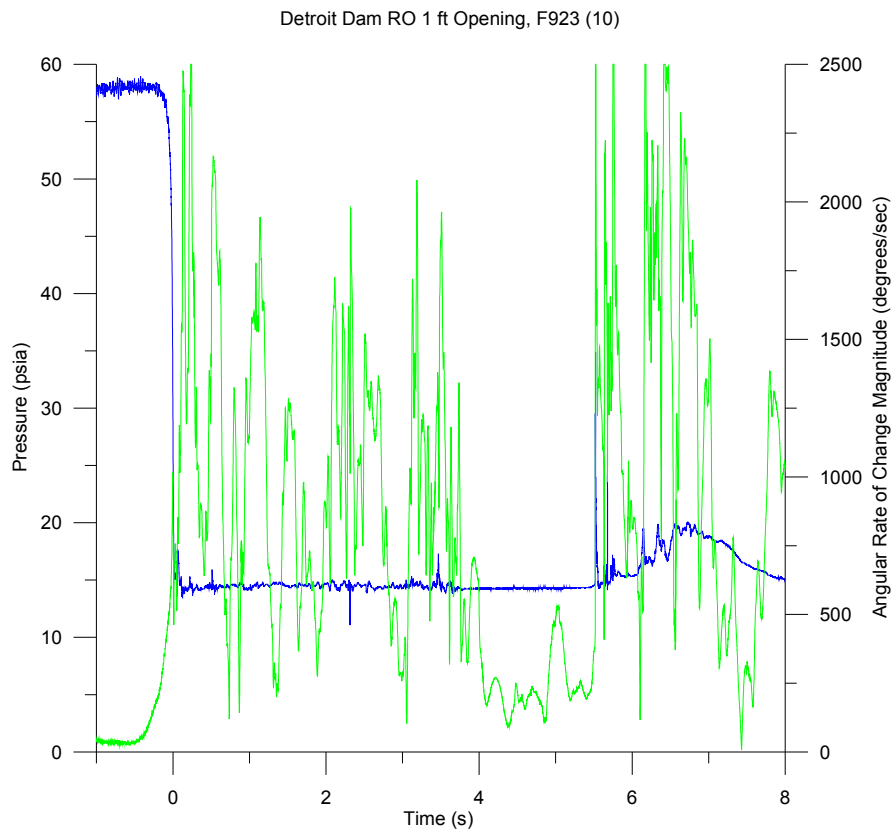
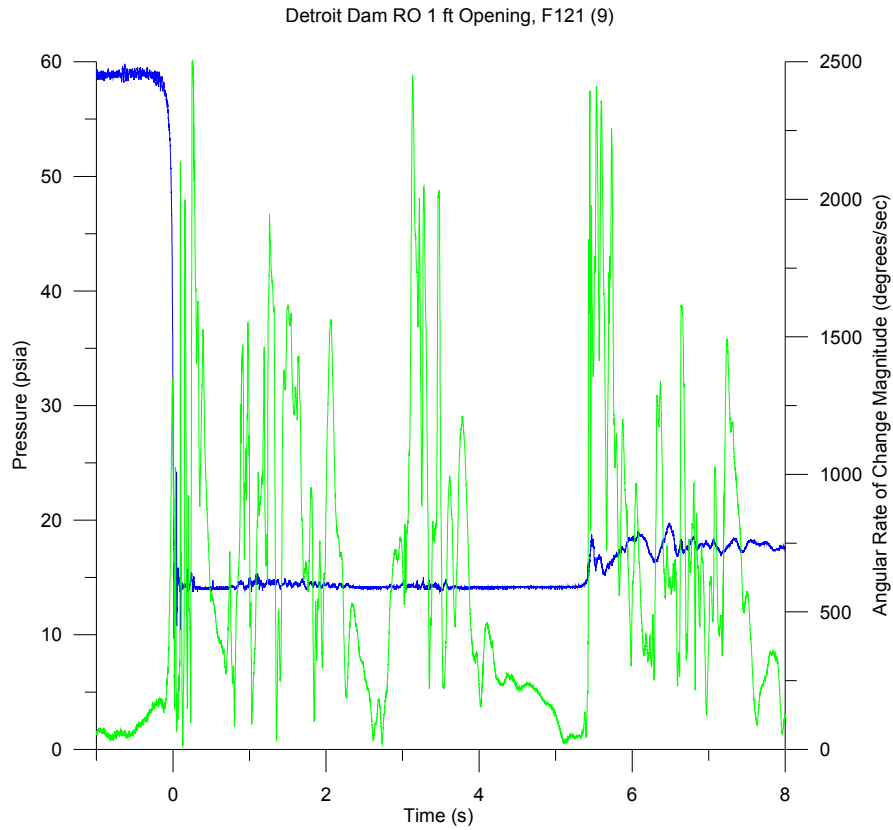
### **1-ft Gate Opening**

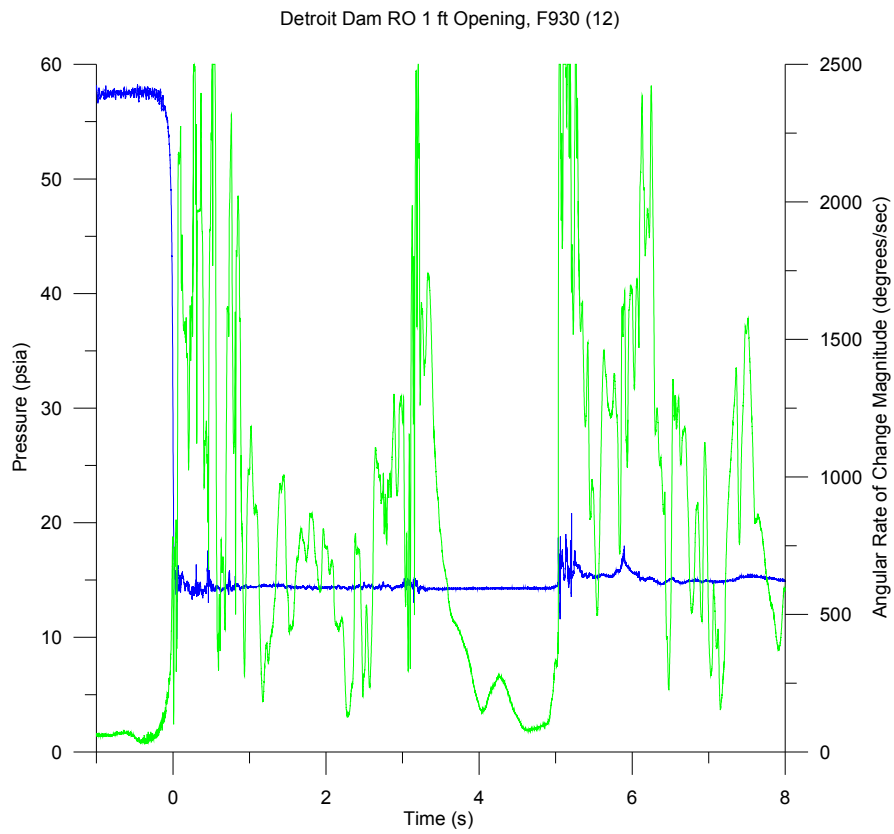
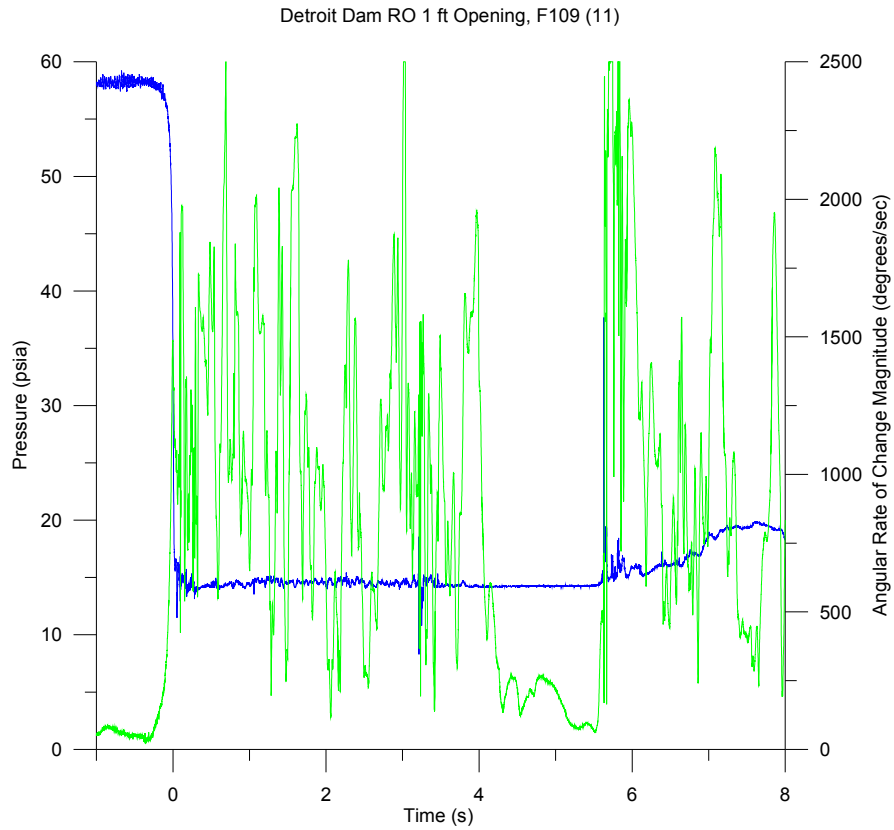






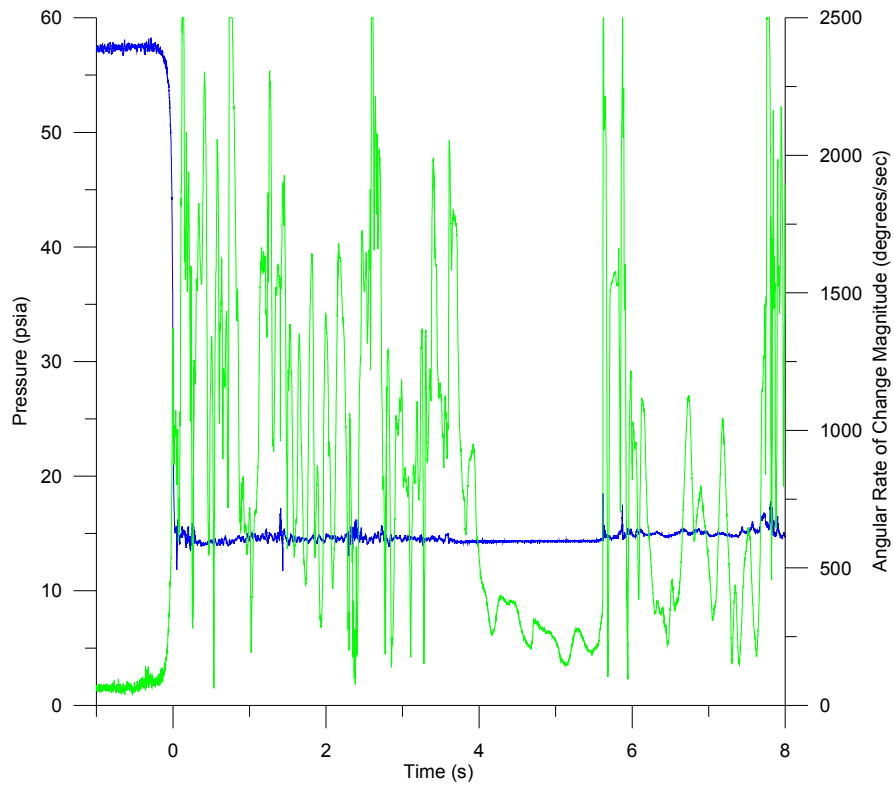




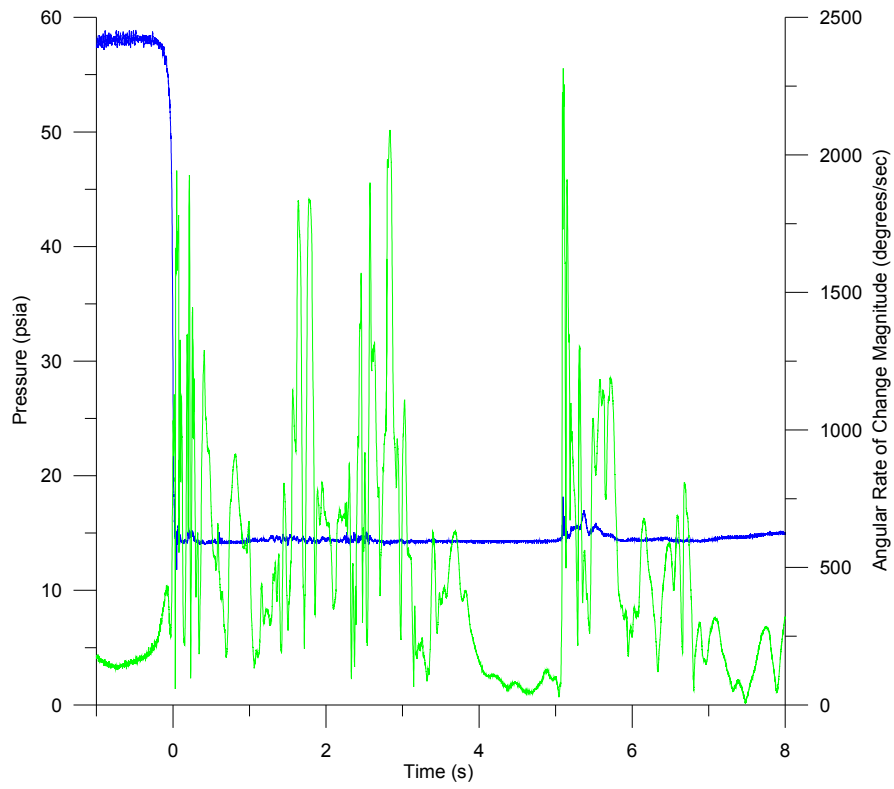


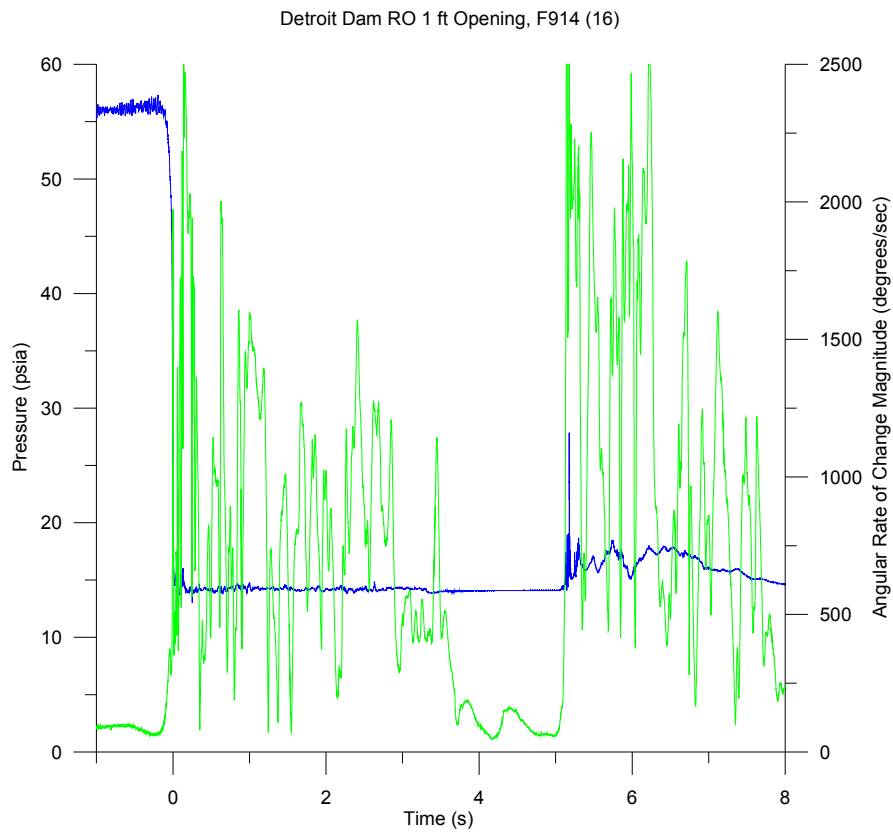
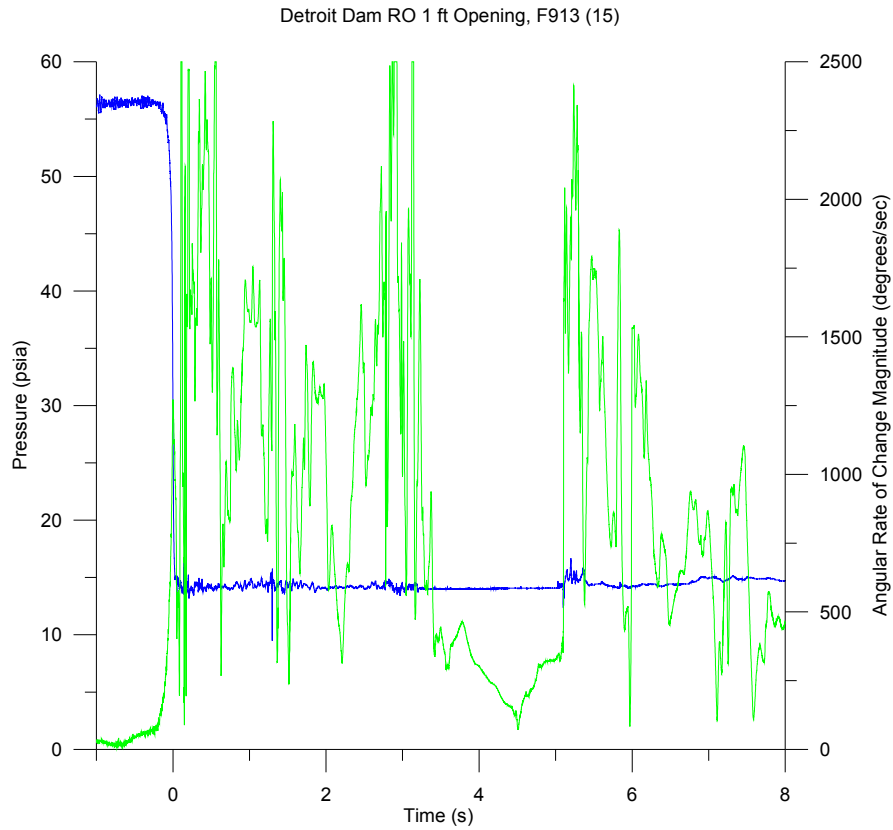


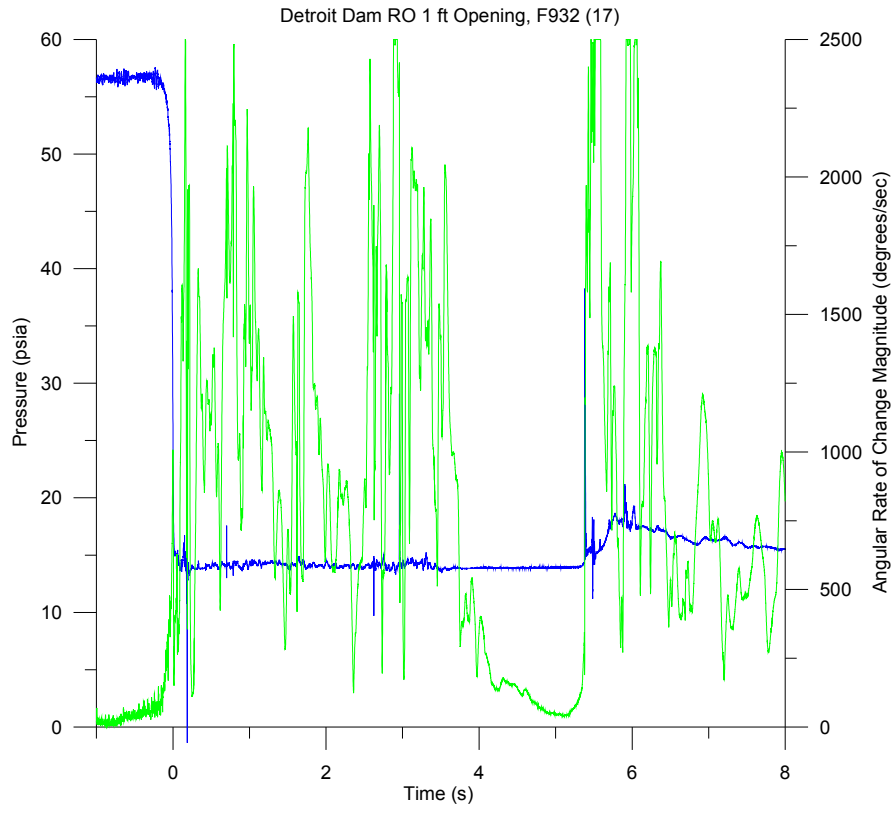
Detroit Dam RO 1 ft Opening, F931 (13)



Detroit Dam RO 1 ft Opening, F121 (14)

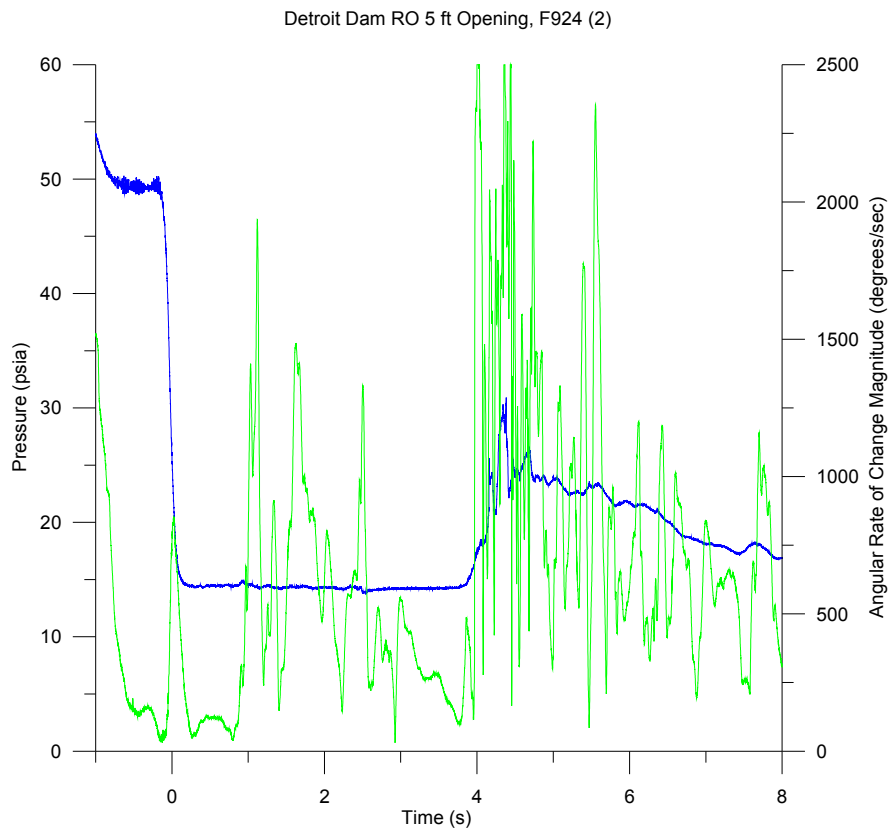
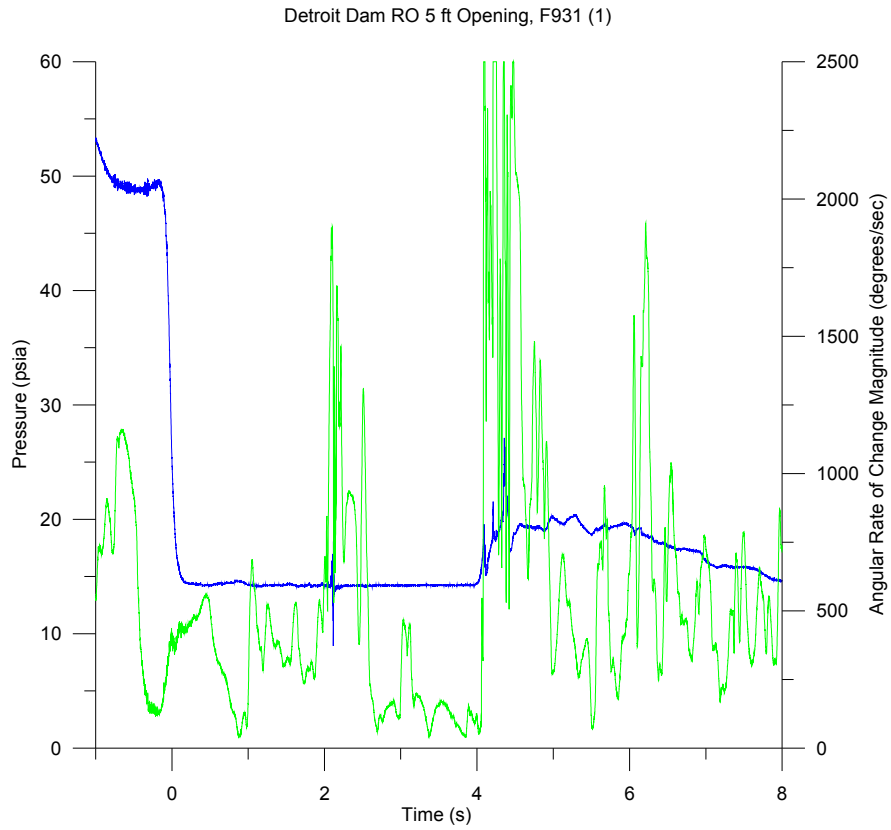


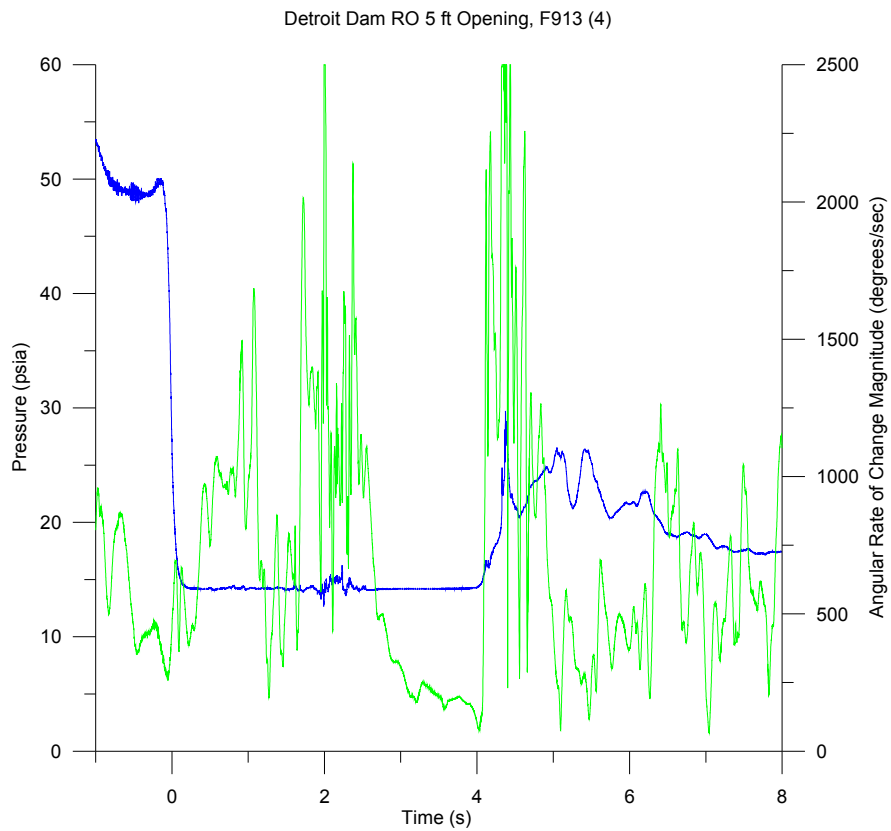
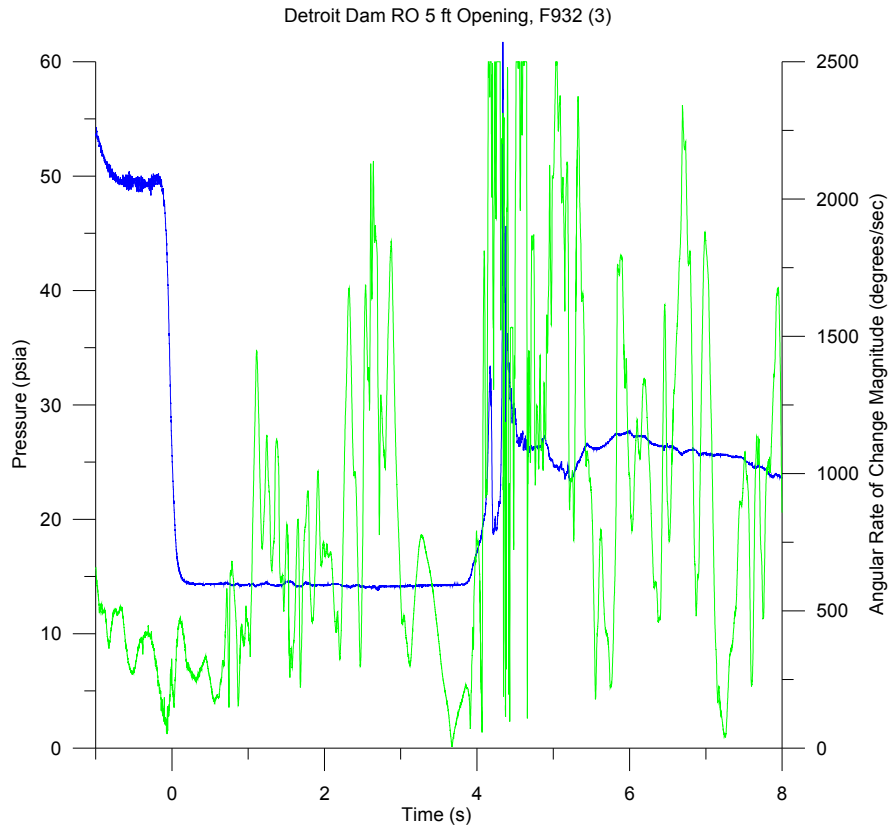


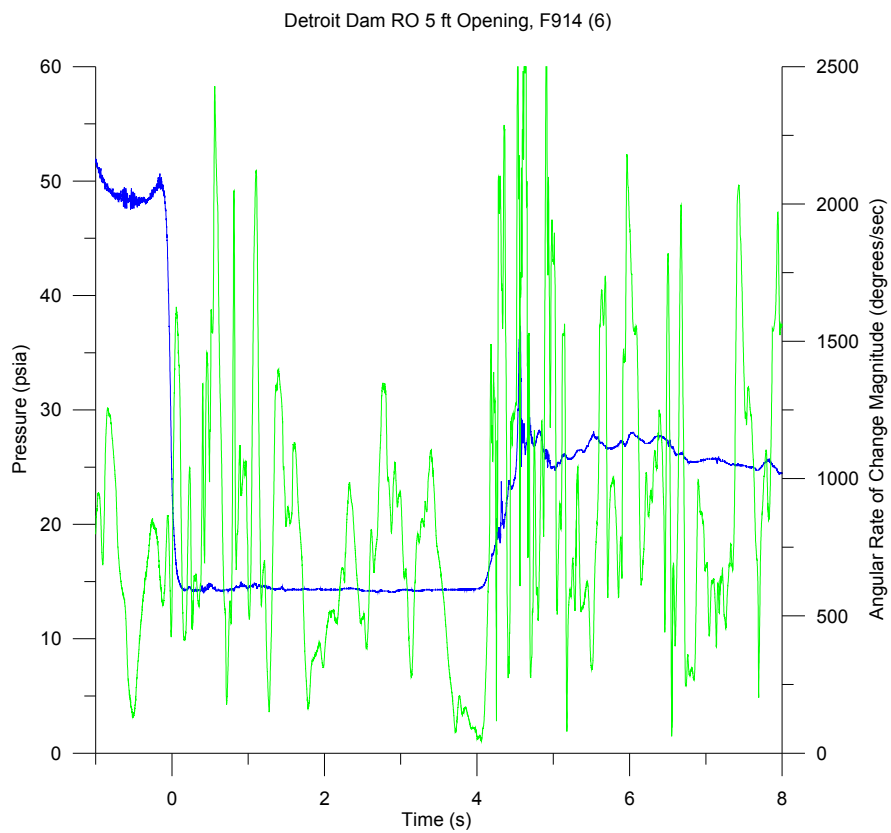
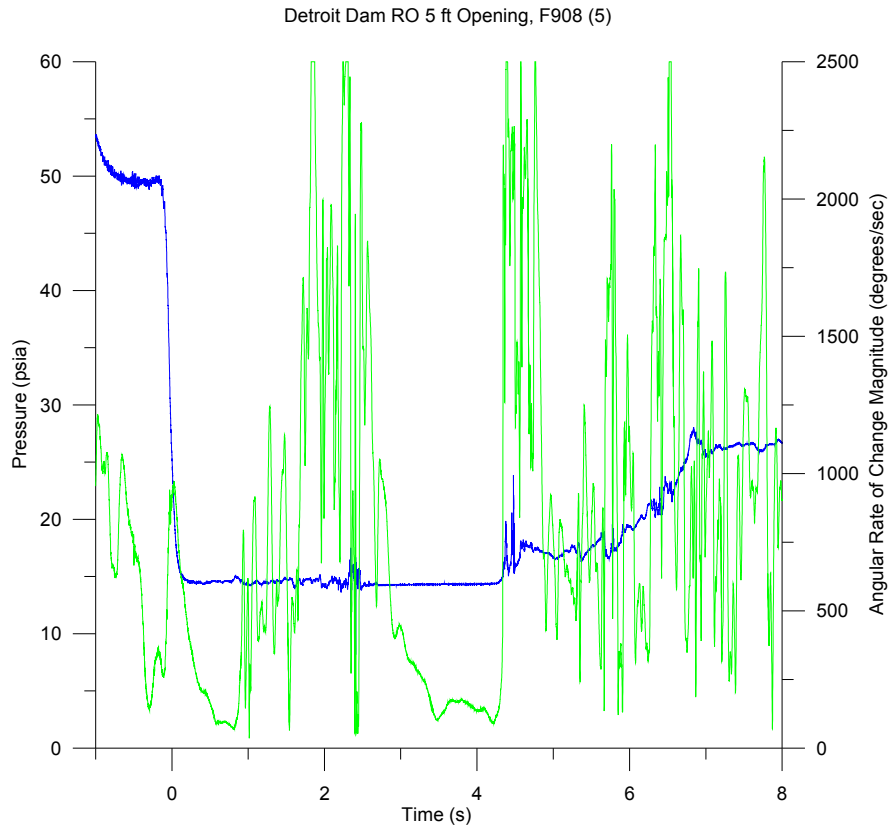


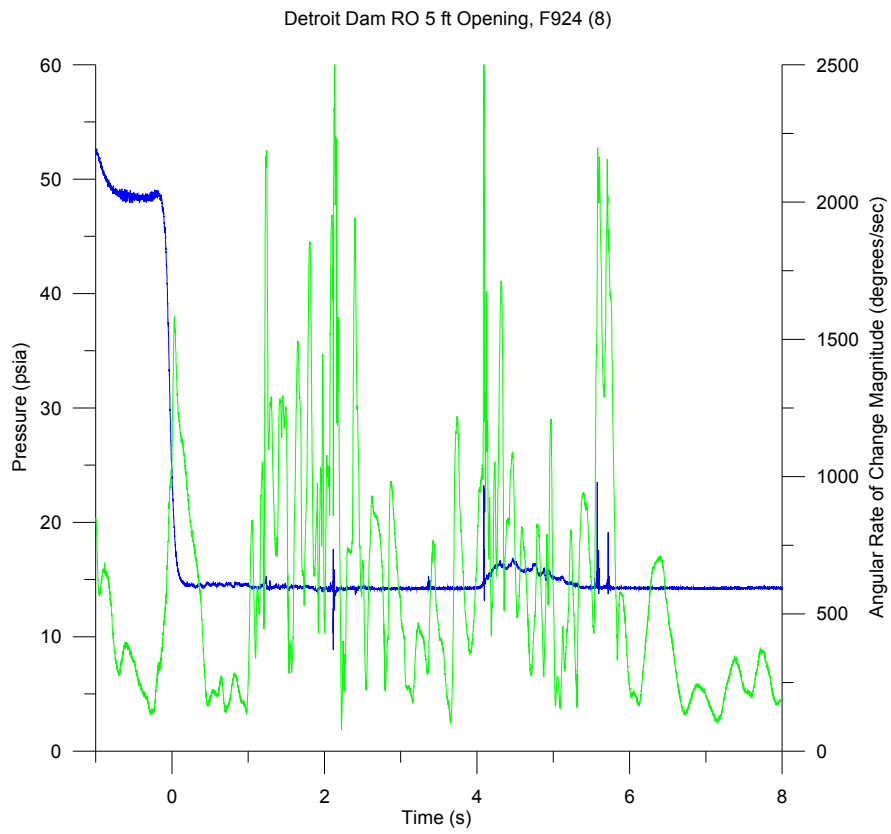
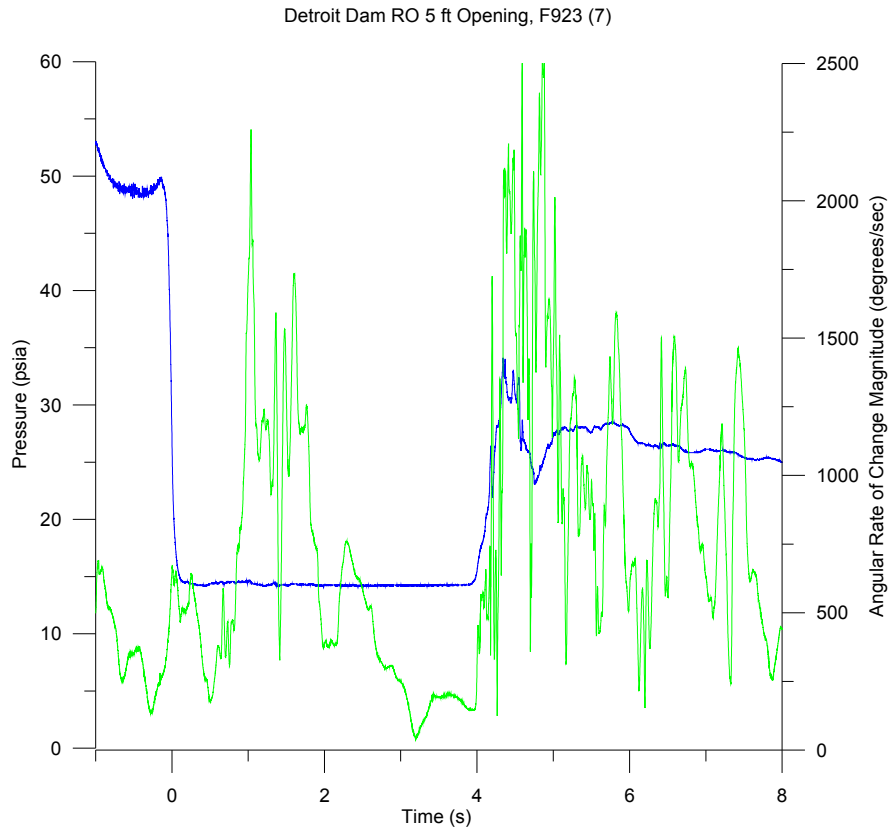
## **Detroit Dam Regulating Outlet**

### **5-ft Gate Opening**

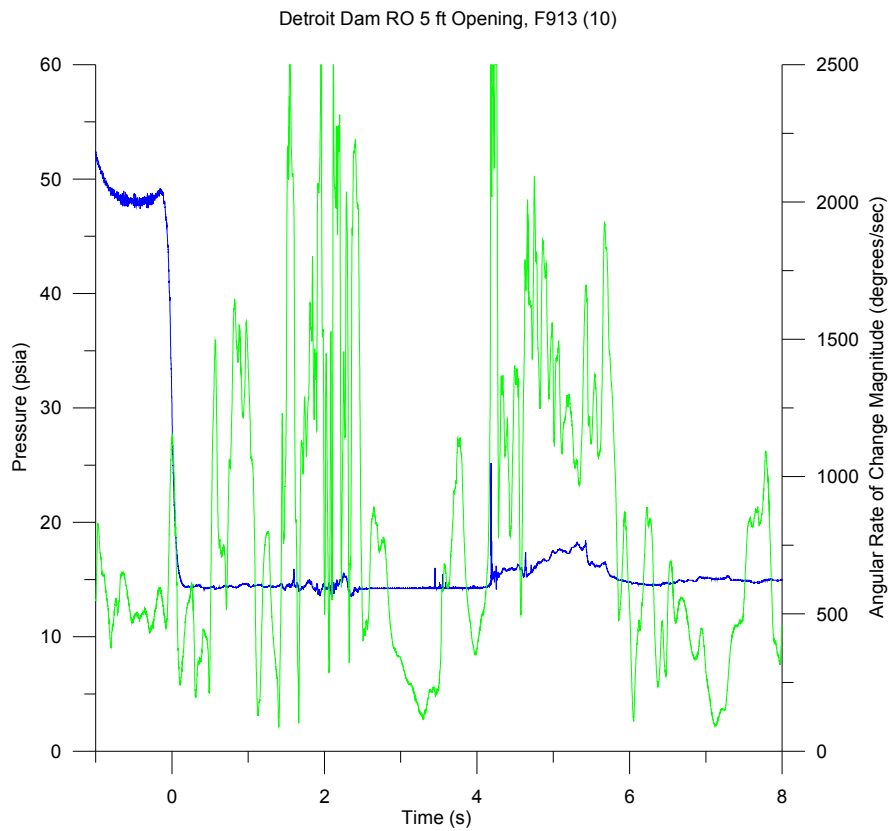
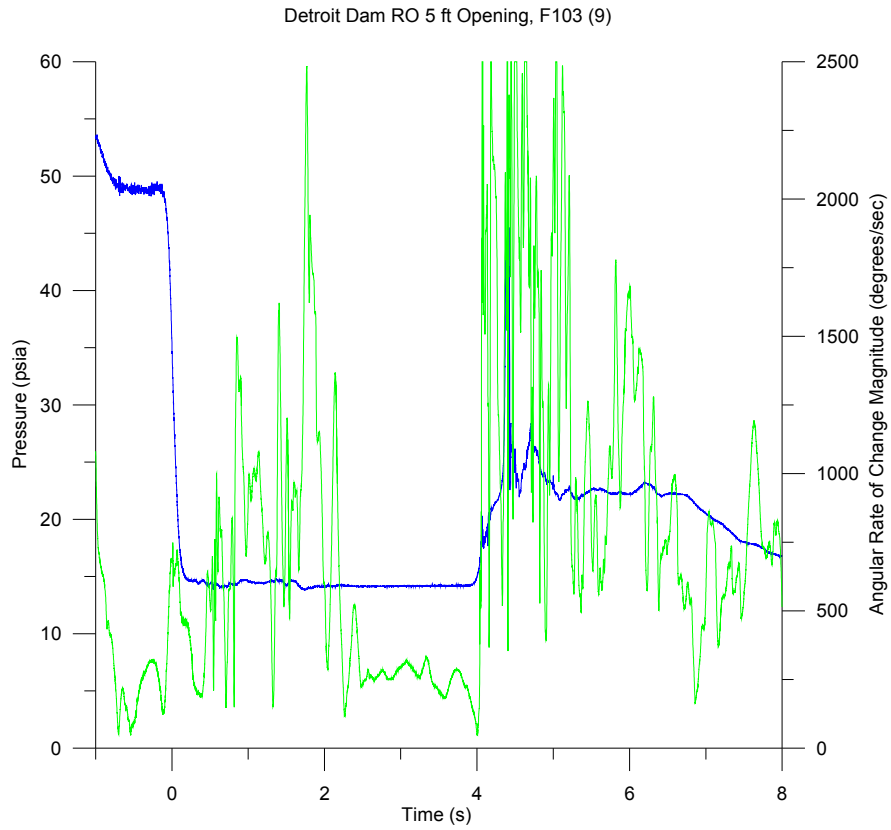


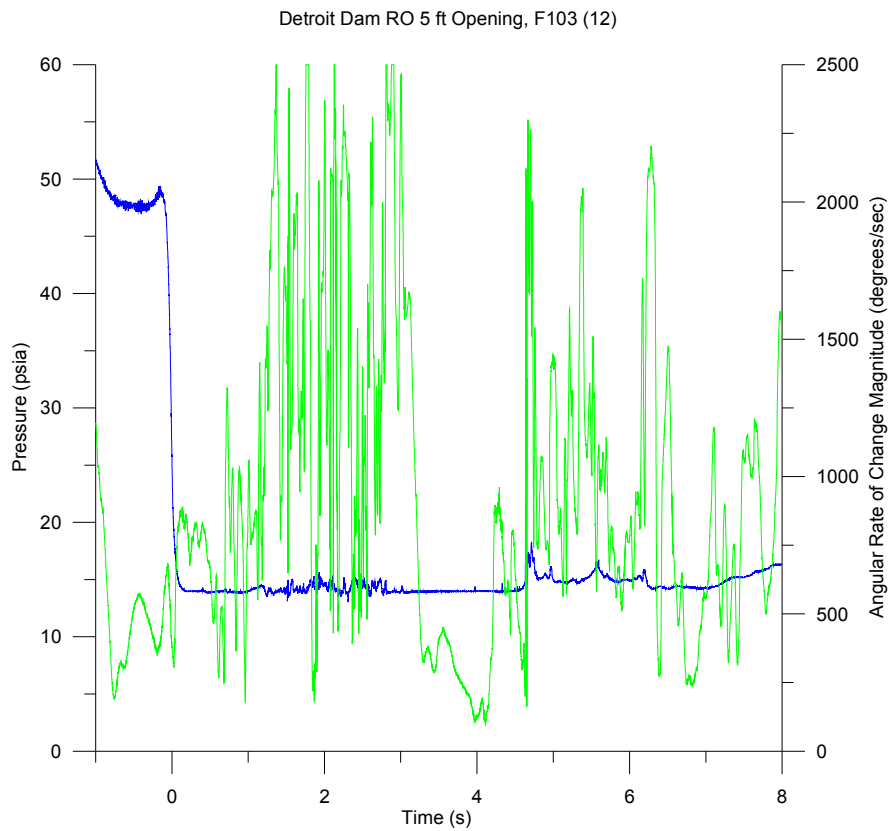
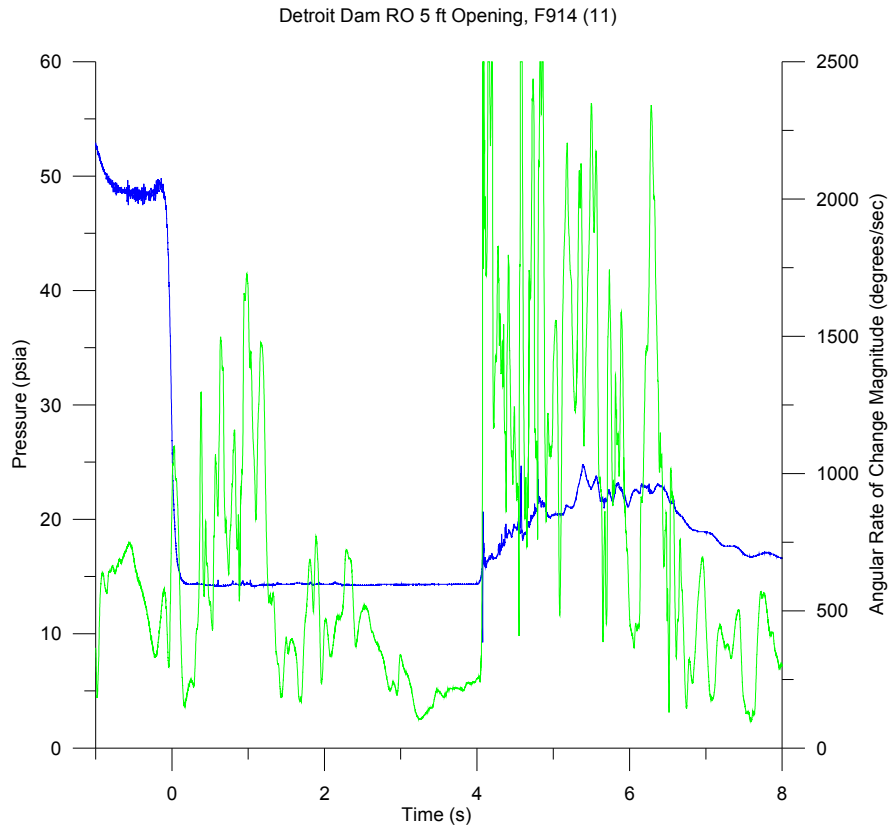


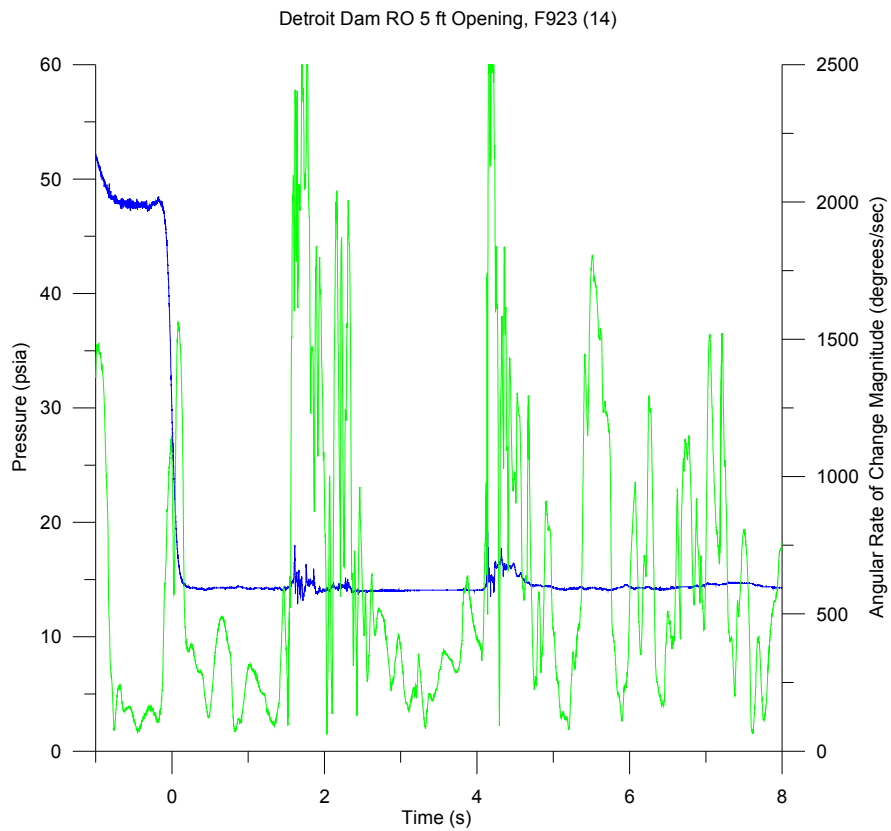
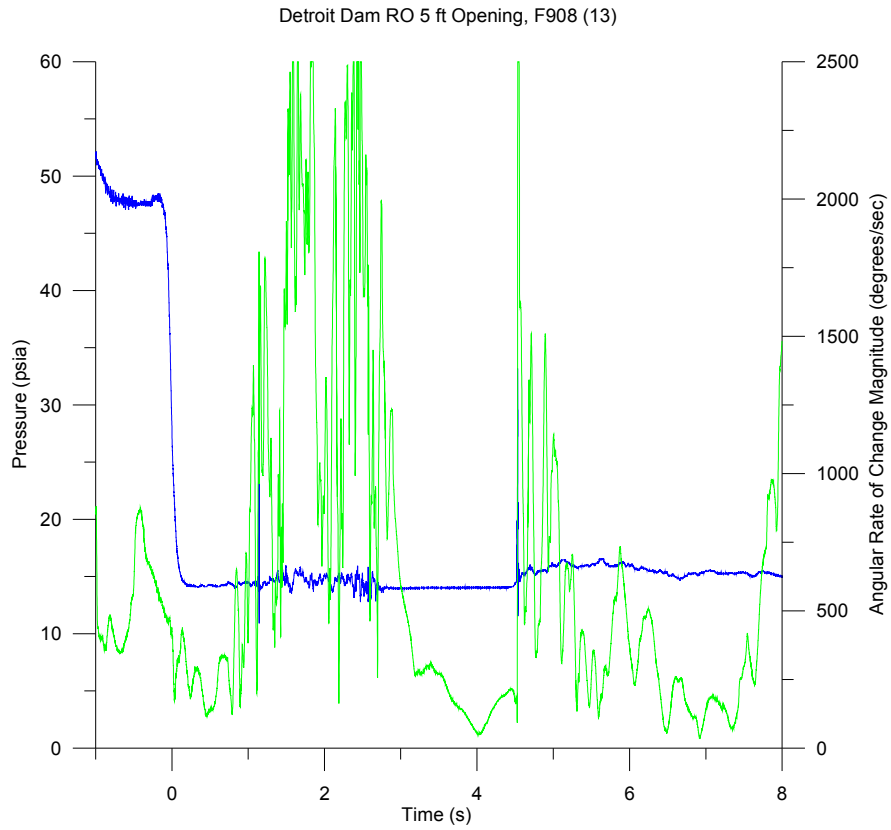


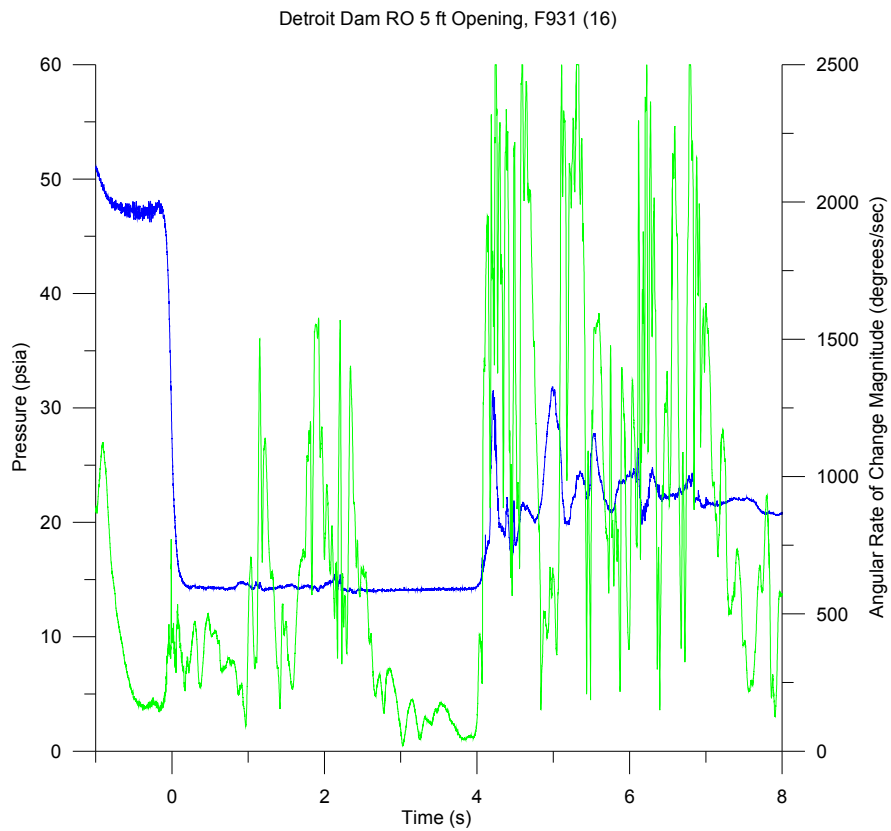
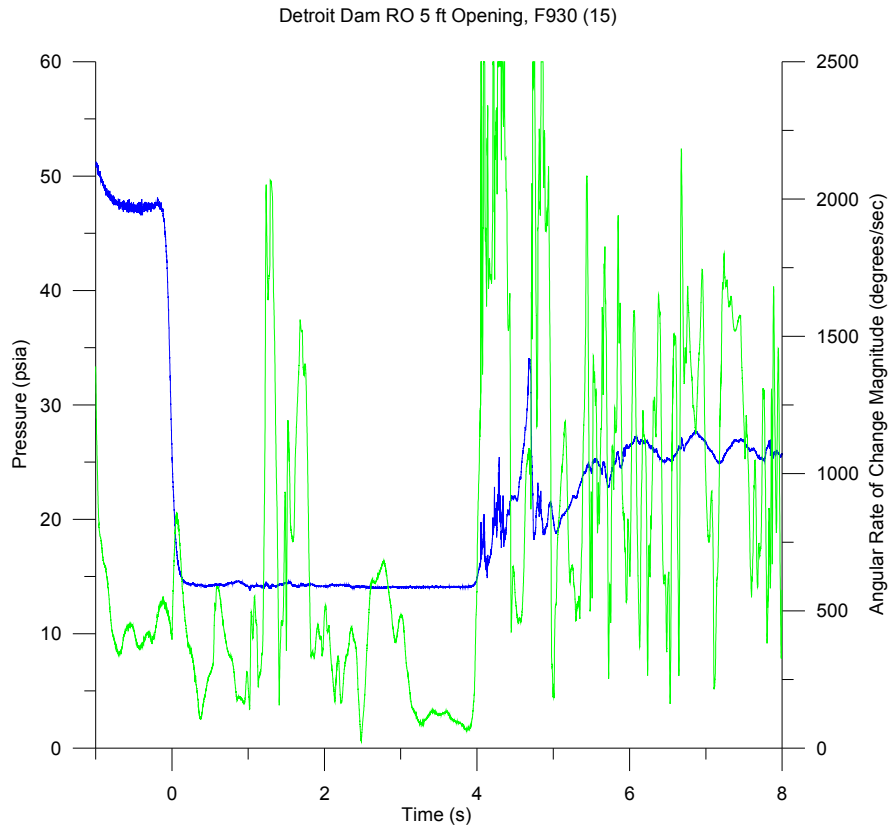


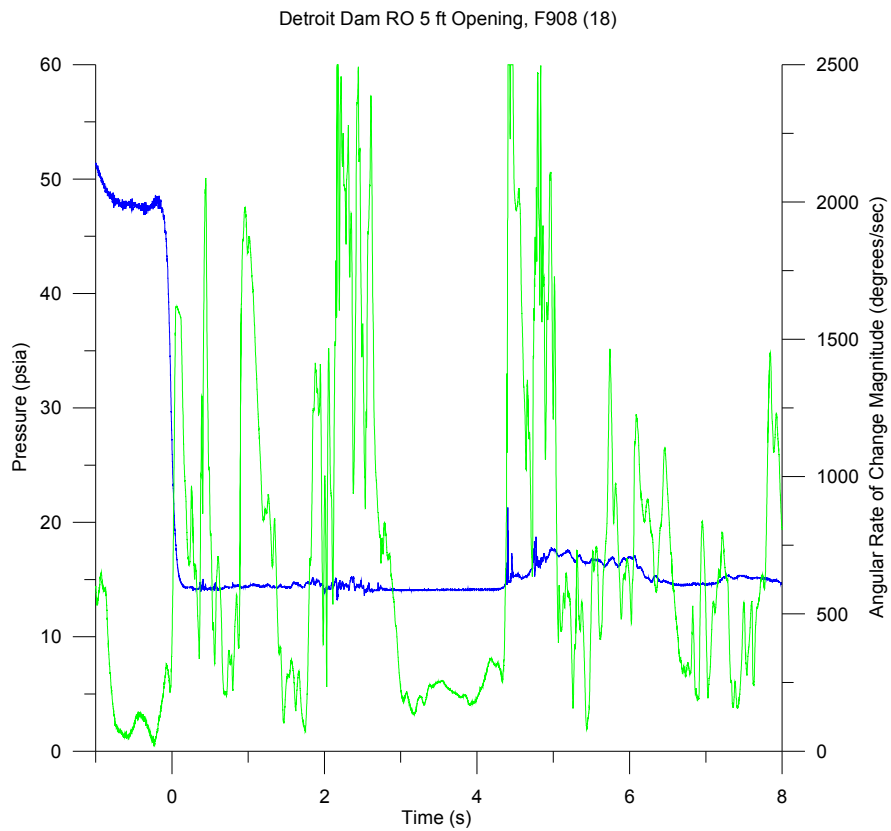
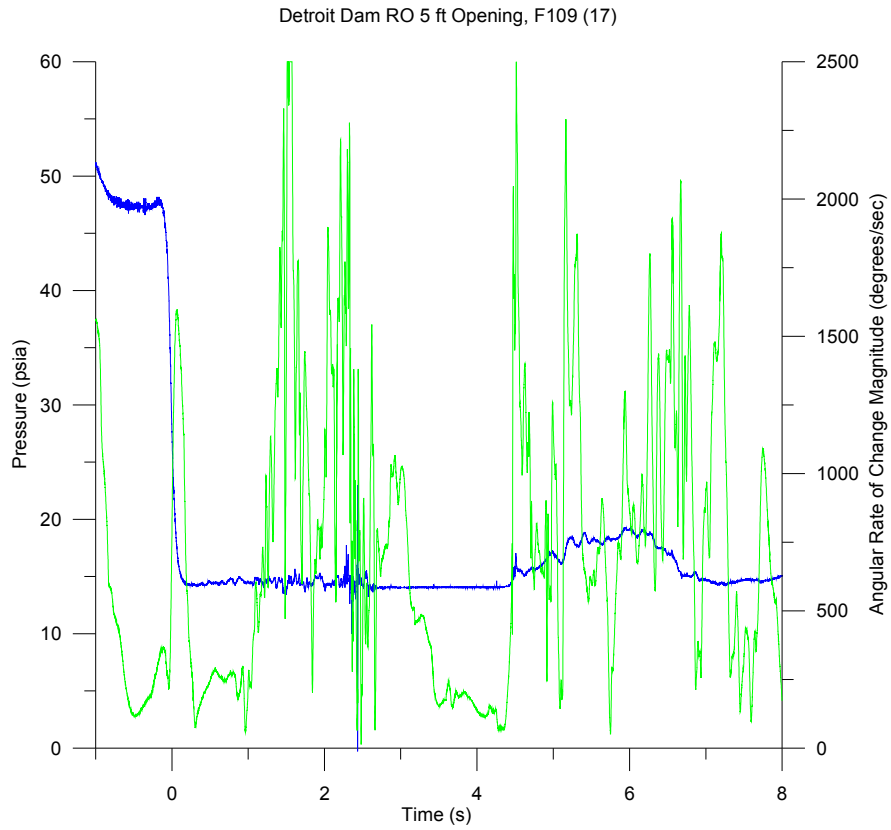


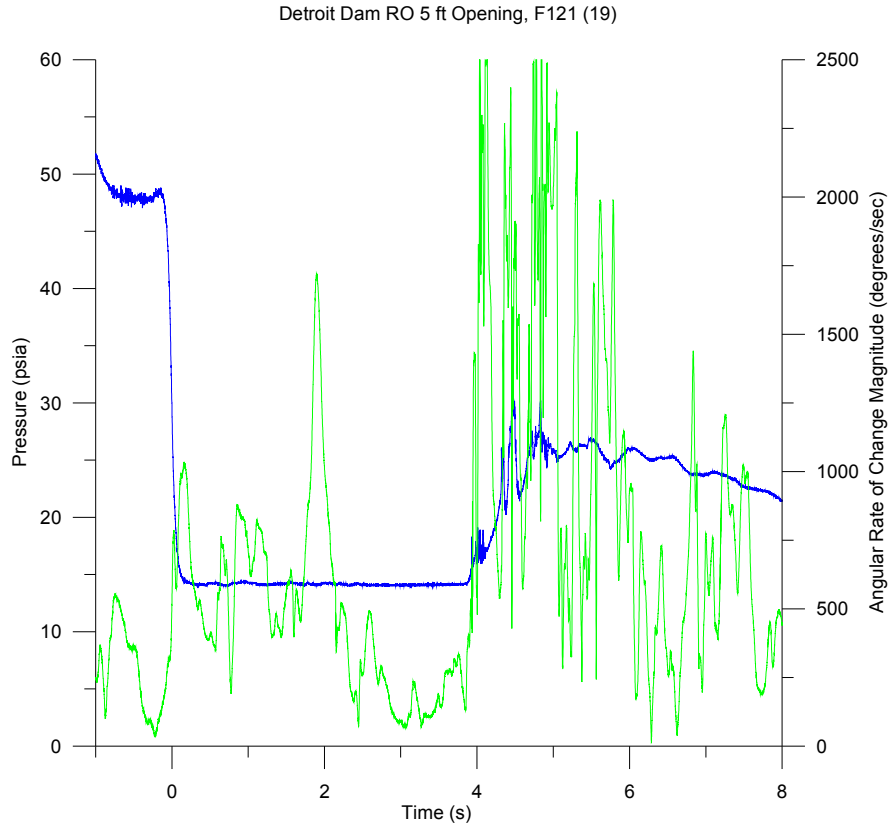




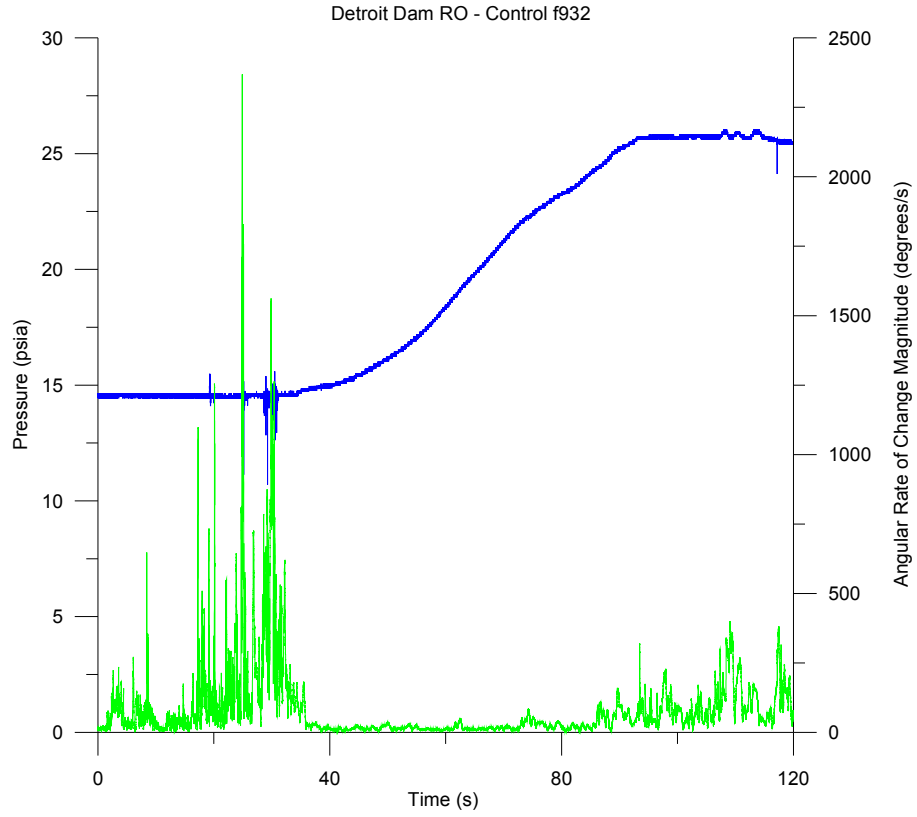








# **Detroit Dam Regulating Outlet Control**







**Pacific Northwest**  
NATIONAL LABORATORY

*Proudly Operated by **Battelle** Since 1965*

902 Battelle Boulevard  
P.O. Box 999  
Richland, WA 99352  
1-888-375-PNNL (7665)  
[www.pnl.gov](http://www.pnl.gov)



U.S. DEPARTMENT OF  
**ENERGY**