



UNIVERSITY OF
GLOUCESTERSHIRE

This is a peer-reviewed, post-print (final draft post-refereeing) version of the following published document, © 2016 IEEE and is licensed under All Rights Reserved license:

**Marie, Mehdi J., Al-Suhail, Ghaida A. and Al-Majeed, Salah
ORCID: 0000-0002-5932-9658 (2017) Client-server based
wireless networked control system. In: 2016 IEEE East-West
Design & Test Symposium (EWDTS), 14-17 October, Yerevan,
Armenia. ISSN 2472-761X ISBN 978-1-5090-0693-9**

Official URL: <https://doi.org/10.1109/EWDTS.2016.7807627>

DOI: <http://dx.doi.org/10.1109/EWDTS.2016.7807627>

EPrint URI: <https://eprints.glos.ac.uk/id/eprint/5578>

Disclaimer

The University of Gloucestershire has obtained warranties from all depositors as to their title in the material deposited and as to their right to deposit such material.

The University of Gloucestershire makes no representation or warranties of commercial utility, title, or fitness for a particular purpose or any other warranty, express or implied in respect of any material deposited.

The University of Gloucestershire makes no representation that the use of the materials will not infringe any patent, copyright, trademark or other property or proprietary rights.

The University of Gloucestershire accepts no liability for any infringement of intellectual property rights in any material deposited but will remove such material from public view pending investigation in the event of an allegation of any such infringement.

PLEASE SCROLL DOWN FOR TEXT.

Client-server based wireless networked control system

Mehdi J. Marie

Dept. of Electrical and Computer Engineering, University of Basrah, Basrah, Iraq

Ghaida A. Al-Suhail

Dept. of Electrical and Computer Engineering, University of Basrah, Basrah, Iraq

Salah Al-Majeed

Dept. of Systems Engineering, Military Technological College, Oman

© 2016 IEEE

Abstract:

There are tremendous developments and achievements during recent years, related to the use of wireless technologies in industry to provide flexibility, scalability and low cost. Wireless Networked Control Systems (WNCSs) based on Wireless Sensor Networks (WSNs) integrate three technologies: control engineering, computer networks and wireless communication. WNCSs are systems of smart and wirelessly connected devices equipped with limited communication, computation and sensing capabilities for control and monitoring applications. The design, building and implementation of a WNCS for a FlyWheel Position Control System (F-W PCS) are based on the XBee platform. A simulation of the wireless networked F-W PCS mathematical model was implemented using the TrueTime 1.5 MATLAB/Simulink Toolbox with the wireless networks between controller and plant nodes employing ZigBee (IEEE802.15.4) and Wi-Fi (IEEE802.11) protocols. The real-time wireless F-W PCS was realized and implemented successfully. Experimental set-up and simulation results show the feasibility and reliability of the system when it is compared with more traditional networked control systems.

SECTION I.

Introduction

The last decade has witnessed great advances in computing, communication and control engineering. Tiny devices have been introduced, with the capability of performing sensing and actuation by computation and communication with other devices. Now there are tools available to develop intelligent complex systems that enable more efficient use of energy, enhance Wireless technologies have witnessed pollution monitoring systems and environment surveillance. Productivity in industrial plants also can be enhanced. Fig. 1 shows a Venn diagram that represents the intersection area of Wireless Networked Control Systems (WNCSs) which lies between Control (C^1), Communication (C^2) and Computing (C^3) engineering fields [11]–[12].

Closed-loop Networked Control Systems (NCSs) are spatially distributed control systems in which communication between sensors, actuators and controllers occurs through a shared band-limited digital communication network. There are two types of these systems in terms of the medium used at the physical layer: wired lines and wireless [3].

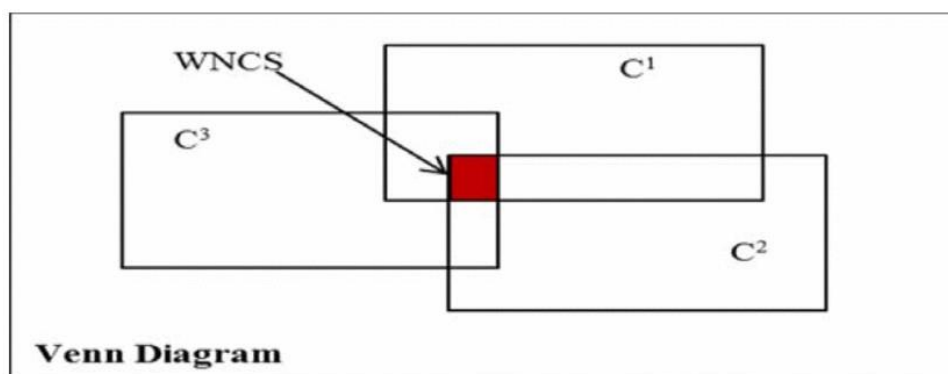

Fig. 1: Venn diagram to represent the WNCS field

Traditionally NCSs are used widely to reduce weight and the cost, and to increase reliability and connectivity. There are many types of communication networks, which have been developed during few years, networks used successfully to monitor and control a wide variety of systems and processes [4].

In wireless networked systems, communication among different components relies on wireless technologies. Wireless networking is gaining significant momentum in several areas of applications due to advantages such as mobility, configurability, and spatio temporal sensing. While the initial utilization of wireless communication was for sensing and communication with Wireless Sensor networks (WSNs), a new field has now emerged that uses the same techniques for enabling network control systems [5].

The WNCs research area can be categorized into three main fields [6]:

1. Design of networks: study and research on the communication and networks to make them suitable for real time NCSs routing control, congestion reduction in packet flow, efficient data communication and networking protocols.
2. Control of networks: this area deals with control strategies and control systems design of wireless networking, with aim of minimizing the effects of adverse network parameters on the control system performance and stability such as network delay.
3. Multi-agent system studies on how network architectures and interactions between network components (nodes) influence the global control goals. 4. More precisely the problem here is to understand how local laws describing the behavior of the individual agents influence the global behavior of the networked control system.

There are new research challenges in how to enhance Quality of Performance (QoP), reliability and system accuracy. The deployment of these devices (nodes) facilitates the problem of convergence since they need small amount of power and can communicate over a considerable distances.

The rest of this paper is arranged as follows. Section 2 reviews to previous related work. Wireless automatic control systems are described in section 3 while section 4 covers client-server schemes. The demonstration plant description and mathematical model are given in sections 5. The paper is concluded in section 6.

SECTION 2.

Related Work

There are many research works in the field of networked control and WNCs in particular over the last ten years, resulting in a very many publications the most recent of which are reviewed below.

In 2007, Nikolakopoulous *et al.* [7] proposed a multi-hop induced gain scheduler for WNCs. The suggested control scheme is based on the client-server architecture. In 2007, Dritsas *et al.* [8] modeling approaches for NCSs with different types of varying communication latency times are presented. In 2008, Nikolakopoulous *et al.* [9] presented an experimental optimization of a wireless transmission scheme, coupled to a tuning process of the controller parameters for real-time control applications.

In 2008, Uchimura [10] described wireless networked control systems with variable time delay paths. The work focused on a packet based network in which subsequent packets catch up the preceding packets to compensate the loss. In 2009, Amarawardhana *et al.* [11] described the general architecture of WSNs and SCADA networks and commonly used communication protocols. A case study was presented using the XBee platform.

In 2009, Dai *et al.* [12] presented a scheduling strategy for a collection of discrete time networked control systems subjected to communication constraints such as network induced time delays and packet dropout. In 2010, Nikolalopoulous *et al.* [13] applied the predictive control model for attitude control of unmanned quad rotor helicopter for image compression and wireless transmission. In 2010, Li *et al.* [14] built a wireless PLC

system to control the remote field devices without wiring. They used an XBee modem to build the wireless network between the master station (controller) and the remote devices (plant).

In 2010, Bemporad *et al.* [15] presented the design and experimental validation of Model Predictive Control (MPC) of hybrid dynamical processes with wireless sensors. In 2010, Kaltiokallio *et al.* [16] addressed the delays and performance analysis under packet loss of the PIDPLUS controller against PI and PID controllers. In 2011, Park *et al.* [17] investigated the essential issues of wireless networked control systems by considering the effect of the wireless network on control performance and then proposed a co-design approach to meet the desired control cost while minimizing the energy consumption of the network.

In 2011, Lemmon and Hu [18] established the sufficient conditions for the almost sure stability of the NCSs under random drop-outs. These conditions relate the burstiness of the drop-out process to the nominal response of a system controlled by a wireless communication network. In 2012, Choi *et al.* [19] proposed a packet loss compensation technique for cyber-physical control over a wireless network. They used the Zigbee protocol as a wireless medium access and communication network. In 2012, Qu *et al.* [20] addressed the stabilization problem for WNCs with impulse disturbance in the discrete time domain. They modeled the packet loss according to the Bernoulli process.

In 2013, Ulusoy *et al.* [21] introduced a networked control system method called the wireless model based predictive networked control system and implemented a control system using IEEE 802.15.4 (ZigBee) as a communication protocol. They presented simulation results on the performance of the controlled system under large amounts of random network delays and data loss.

SECTION 3.

Wireless Automatic Control Systems

From an engineering point of view, a well-designed WNCS (as shown in Fig. 2) has to be adaptable enough to control its actions and it also must be able to perform desired functions precisely and accurately. However, there are some particular characteristics that a WNCS must have [12]. Knowing and understanding these characteristics may help us to design systems for efficient working and to ensure that a WNCS has the capability to achieve certain useful tasks. The WNCSs must have the following metrics [7], [22]:

1. Link quality and reliability

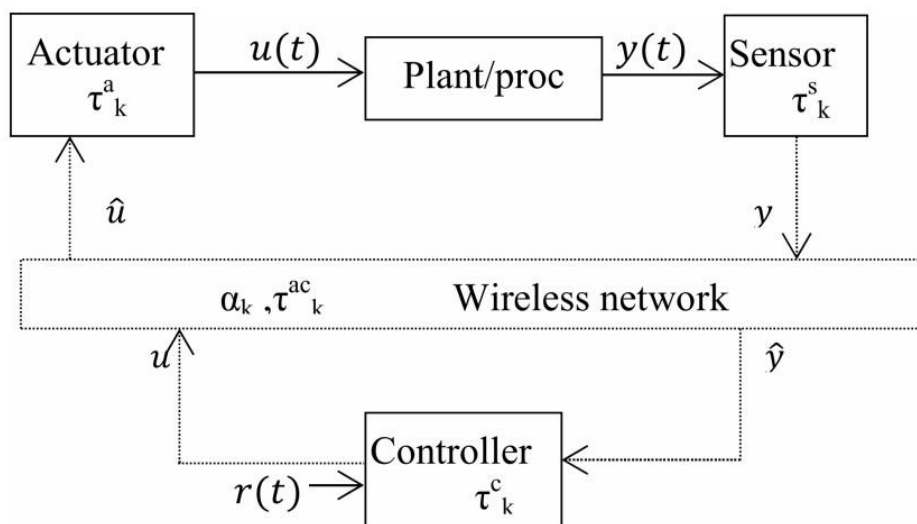

Fig. 2: General structure of WNCS

2. Time delays and jitter
3. Security
4. Energy consumption
5. Flexibility
6. Control paradigms
7. Scalability
8. Distance between nodes

In particular, a tradeoff exists between control and communication performances. Therefore, control system theories and wireless communication protocols should be designed cooperatively.

As shown in Fig. 2, the output of a plant/process ($y(t)$) is sensed by the sensor (S) which has a delay time (τ_s) for sampling and decoding. It is sent to the Controller (C) over the wireless network from the client side. A delay time (τ_c) and switching function (β) are considered for transmission of packets. At the client side, the signal will require a time for processing and it can be considered as a delay time (τ_{sc}). The control signal (u_k) will be issued after this time. It will also be sent over the same wireless network. The time delay is denoted as (τ_{ca}) and the switching function is (α). Hence the total time is given by[7]

$$t = \tau_k^s + \tau_k^{sc} + \tau_k^c + \tau_k^{ca} + \tau_k^{sa} \quad (1)$$

It is required to make $t < h$ where h is the sampling interval time for proper operation of wireless networked control system; that is the controller does not compute a new control signal (u_k) unless it receives new sensor measurement (y^{\wedge}_k) and the actuator continues to utilize the old control signal (u^{\wedge}_k) to actuate the plant/process to the required state of operation. The estimated output and input can be formulated respectively as

$$\hat{y} = (1 - \beta_k)y_k \quad (2)$$

$$\hat{u} = (1 - \alpha_k)u_k \quad (3)$$

The switching functions of the wireless network represent the probability of the successful arrival of y^{\wedge} and u^{\wedge} . They can be denoted as in Fig. 2 as $\rho_{sc k}$ and $\rho_{ca k}$ respectively with the assumption that

$$\rho_k^{sc}, \rho_k^{ca} = \begin{cases} 1 & \text{data lost} \\ 0 & \text{data recieved} \end{cases} \quad (4)$$

The parameters of the network (τ_k and ρ_k) vary depending on the network traffic, medium access control and the chosen node hardware. The state space model formulation for the process/plant that includes the above parameters is given by

$$x(k+1) = \Phi(h)X(k) + \Gamma_0(h, \tau_k)\hat{u} + \Gamma_1(h, \tau_k) \quad (5)$$

and the predicted output of the plant (is

$$\hat{y}(k) = \rho_k^{sc}(Cx(k)) \quad (6)$$

Then, the estimated control signal $u^{\wedge} k$ at the output of the client can be formulated as

$$\hat{u}_k = \rho_k^{sc} \rho_k^{ca} u_k + (1 - \rho_k^{sc} \rho_k^{ca}) \hat{u}_{k-1} \quad (7)$$

where the definition of Φ, Γ_0, Γ_1 can be further investigated at [10]. The design of the controller depends on the state-space model and it can be given by

$$\hat{u}_k = K(h, \tau, \rho) \begin{bmatrix} x_k \\ \hat{u}_{k-1} \end{bmatrix} \quad (8)$$

It is required to find a formula that include the effect of τ, ρ on the PID controller parameters K_p, K_I , and K_D when the control signal is given as

$$u = f(K, \hat{e}) \quad (9)$$

$$u = K_p + \frac{K_I}{s} + K_D s \quad (10)$$

Where the various K_s represents the controller parameters and can be defined as

$$K_p = f1(h, \tau, \rho) \quad (11)$$

$$K_I = f2(h, \tau, \rho) \quad (12)$$

$$K_D = f3(h, \tau, \rho) \quad (13)$$

The formulation of tuning methods such as the Z-N method can be given in terms of (h, τ, ρ) to tune the controller for the wireless networked control system.

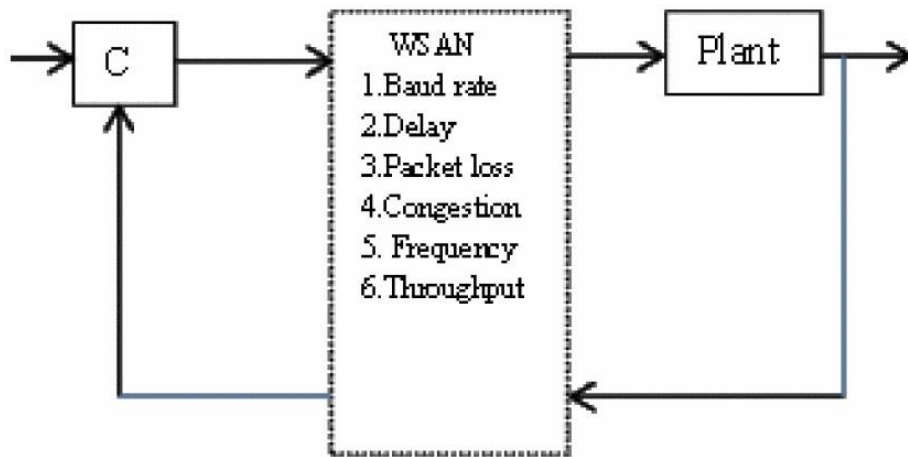

Fig. 3 illustrates the block diagram of a wireless networked control system with the main parameters that affect the network and overall system performance.

SECTION 4.

Client-Server Scheme

The foundations of digital control theory are now well established after almost half a century of research and implementation experience and can be found in [2]–[3][4]. The use of digital computers as an instrument for closed-loop control found large interest after fifteens in the last century. There was a transition from the continuous-time/continuous-states models used in classical feedback designs to the discrete-time/quantized-states models of digital control. New issues such as sampling period selection, finite word length and the resulting quantization effects, limited computational and memory resources had to be addressed in the design of digital control with a special focus on their effects on the control performance. More recently, the field of NCSs was developed in the 1980s and has found many applications in industry.

In the last few years, there has also been a tremendous increase in the deployment of wireless systems, which has triggered the development and research of distributed NCSs. As the concept of WNCSSs started to show its potential in various applications, it also provided many challenges for researchers to achieve reliable and efficient control. After great advances in computer networks and the internet of things, control systems can be implemented remotely using reliable and fast communication channels. A remote control system can be thought of as a system controlled by a controller located far away from it. This is sometimes referred to as tele-operation control. Remote data acquisition systems and remote monitoring systems can also be included in this class of systems. The place where a central controller is installed is typically called a local site while the place where the plant is located is called a remote site which is similar to client-server computer network scheme. The architecture of the client-server control system scheme is composed of two terminal computers; one (client) for implementing the control algorithms such as PID and the other one for plant interfacing and data acquisition (server). Fig. 4 illustrates the general block diagram of this system. The two computers are connected through a communication network, either by wire or wireless. This scheme is first used for connecting the control systems components through TCP/IP or User Datagram Protocol (UDP) of the Internet for remote control applications [8].

A wireless Sensor and Actuator (WSAN) can be used to connect both sides; plant and controller. The output of the plant (measurement from sensors) which can be denoted as $y(t)$ is transmitted over wireless nodes to the controller while the control signal is sent over other wireless nodes to the actuators. The controller in the client side compares the output measurement with the reference signal $r(t)$.

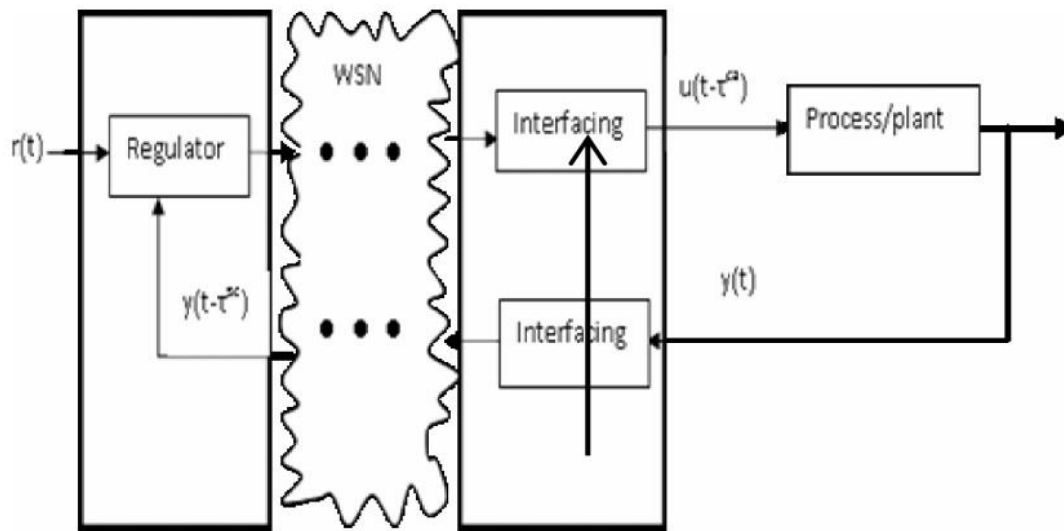

Fig. 4 Client-server scheme

SECTION 5.

Experimental Set-Up

Fig. 5 illustrates the Fly-Wheel schematic diagram. The hardware components of the wireless position control system are composed of three main parts: plant, wireless sensor network devices and controller. The details of each part are given below.

A. Plant (electronic Card of F-W PCS)

- Permanent Magnet DC Motor with Gear-Box
- AT tiny13 Microcontroller
- H-bridge
- Position Sensor (Potentiometer)
- Fly-Wheel
- Small tire

Fig. 5 shows a picture of the F-W PCS with its interfacing card.

B. Interfacing Card

The interfacing card used to connect the plant with the personal computer is an NI USB-6008 from National Instruments (see Fig. 5). At the server side, the connection between the computer and the position control system (F-W PCS) is achieved through this card.

This card is connected to a PC through USB port. The AI and AO blocks of the Data Acquisition (DAQ) tool box of MATLAB/Simulink is used to apply the command signal (0-5V) and record the angle of the flywheel respectively. The software which has been used to drive the NI card is the NI-max [15]. This software interfaces the Simulink blocks of the DAQ toolbox and the plant. The interface with the XBee platform is via the Simulink blocks from Instrument Control Toolbox such as serial send and serial receive.

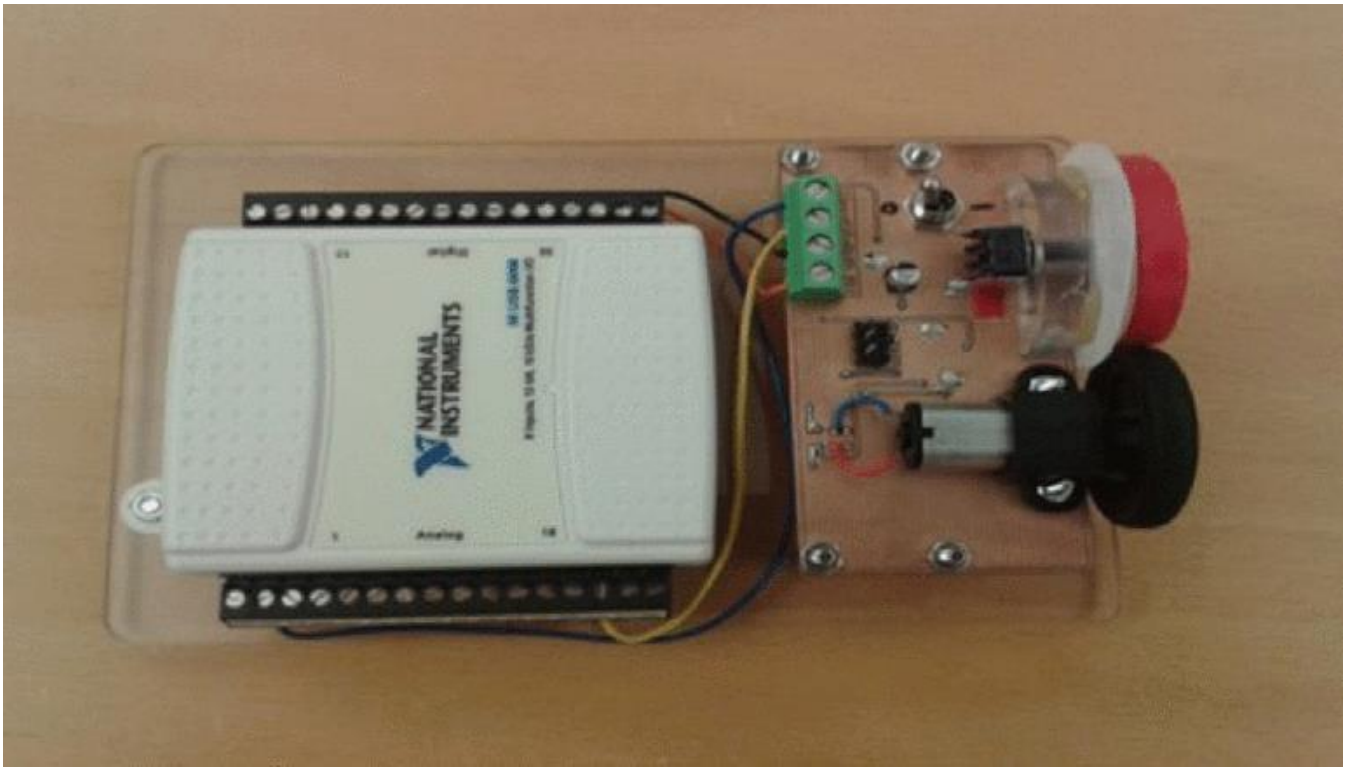

Fig. 5 F-W PCS test-bed picture

SECTION 6.

System Modeling and Control

After the design of the hardware system is completed, the plant is interfaced with the computer via the NI card using MATLAB 2012b. As the MATLAB/Simulink simulation environment provides various powerful tools for control system design, the simulation of wireless networked control systems is carried out using MATLAB and Simulink toolboxes. The WNCS simulation strategy using a particular remote servo control system is illustrated.

The DAQ tool box is used to command the motor to move to a specified angular position utilizing the Analogue Input (AI) block. The angular position of the fly-wheel is sensed by the potentiometer and the Analogue Output (AO) block of DAQ toolbox. Fig. 6 shows the block diagram of the system. The modeling of the fly-wheel position control system is found by using the system identification GUI toolbox of MATLAB 2012b. Fig. 7 and Fig. 8 show the input data (voltage) to the system and the output data (angular position) respectively.

The model of the plant in the frequency domain and can be represented in the following transfer function:

$$\frac{\theta_l}{v_a} = \frac{43}{s(1.127s + 1)} e^{-s} \quad (14)$$

The above transfer function model is estimated from the measured input-output (i.e., voltage-angle) data of the F-W PCS using the System Identification Toolbox of MATLAB.

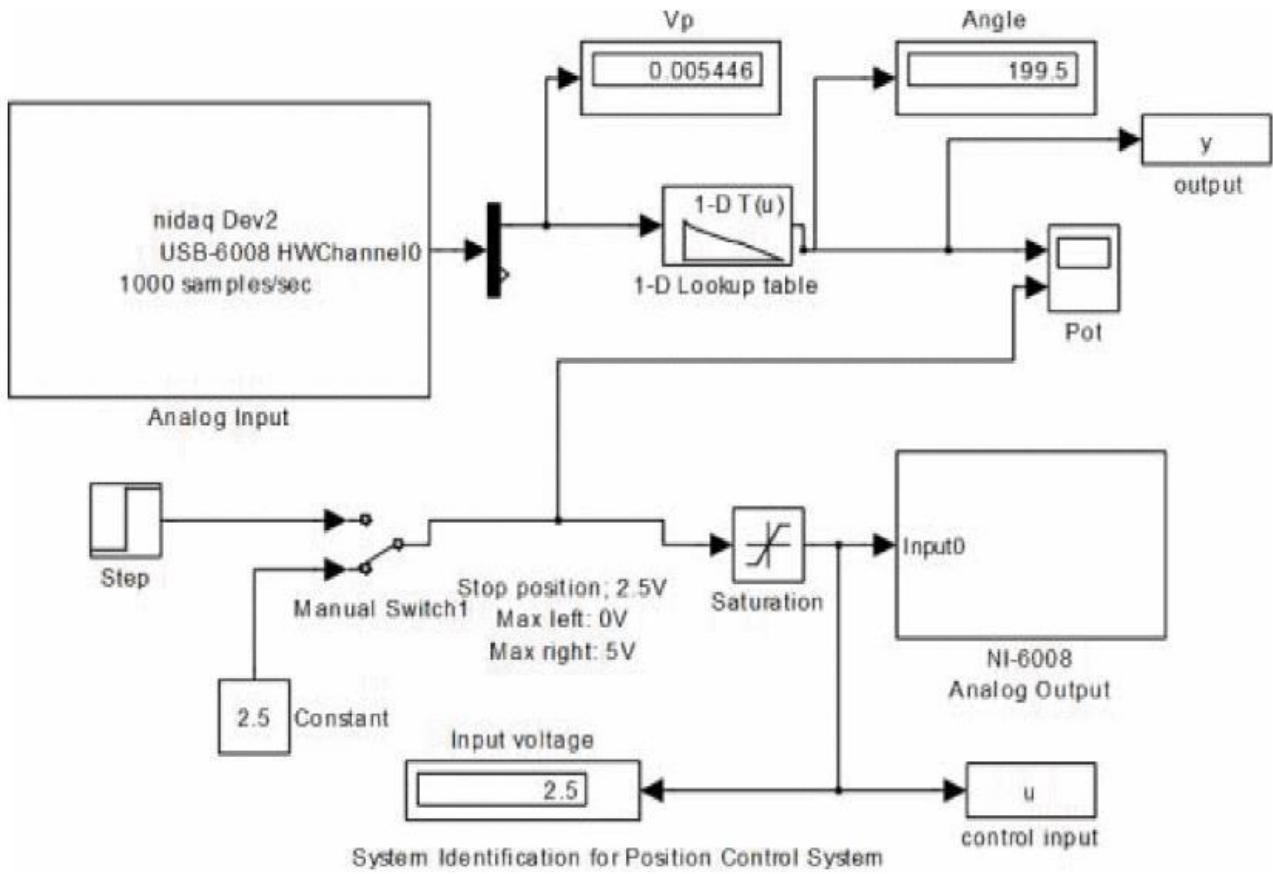

Fig. 6. Simulink diagram for system identification

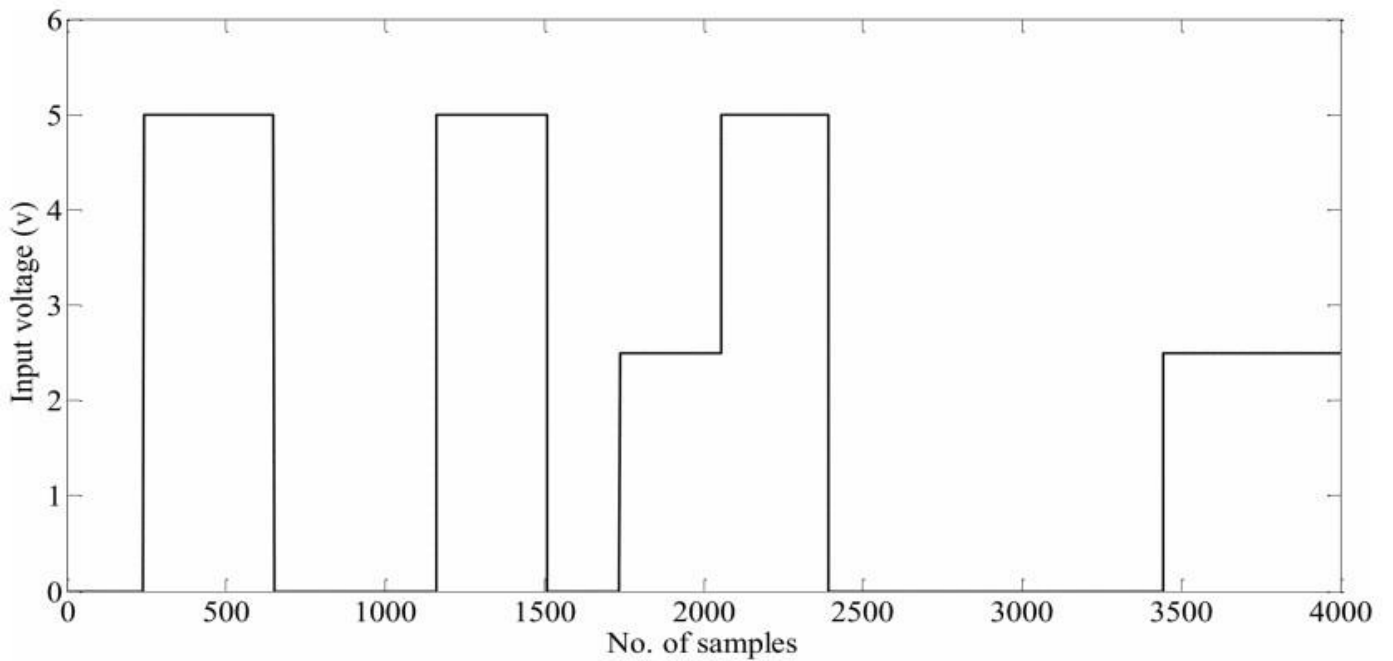

Fig. 7. Input data to the F-W PCS

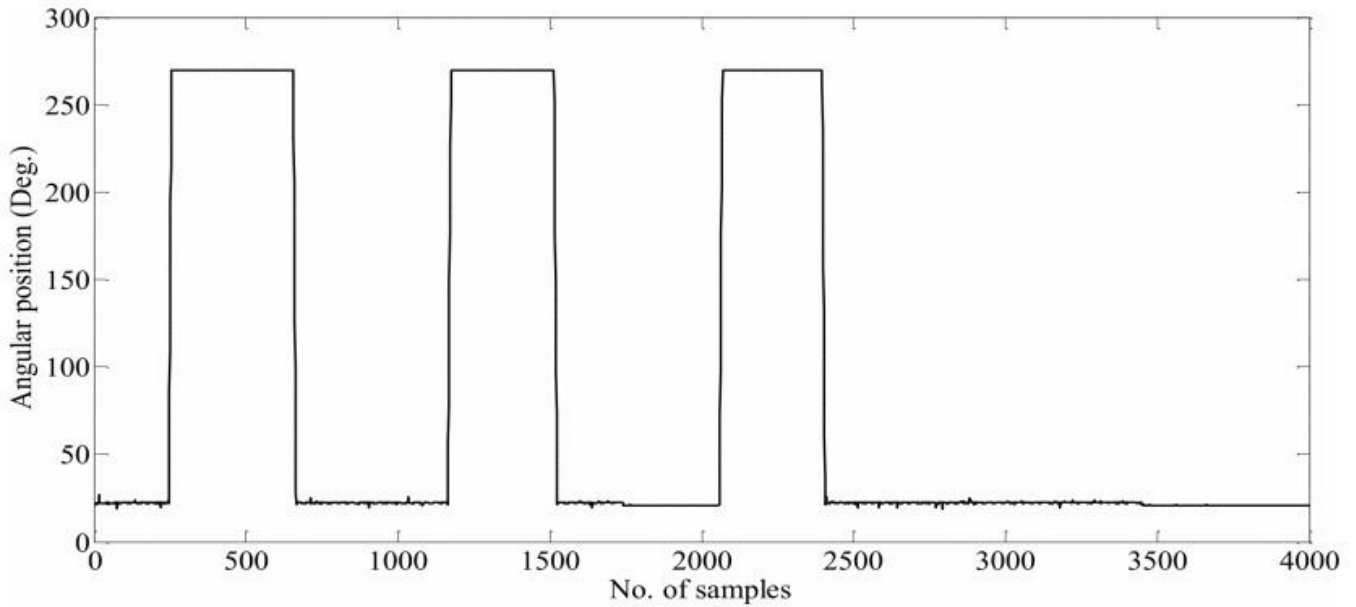

Fig. 8: Output data from the system

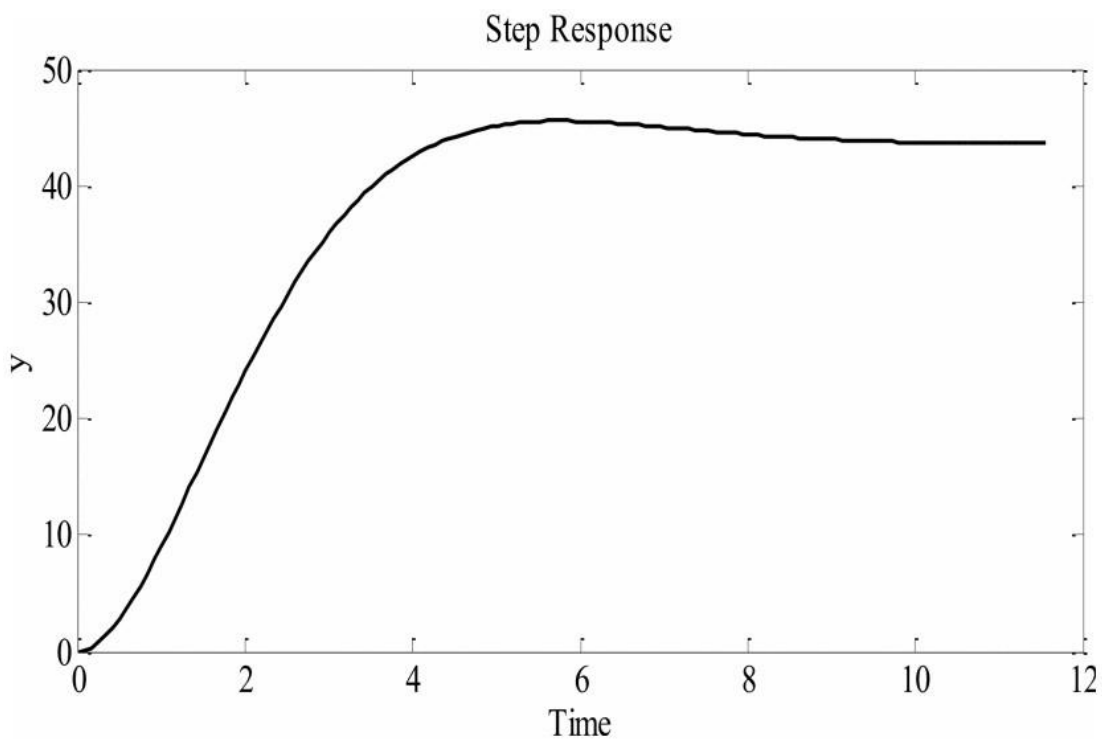

Fig. 9: Step response for F-W PCS model

After completing the hardware and software design of the position control system and allocating the model of the system, a PID controller was designed to regulate the system to track the reference input.

C. PID Controller

The parameters of the PID controller were found by using the Z-N method which depends on the process reaction curve given in the previous section. Table 1 represents the parameters for different types of the PID controller.



Fig. 10: wireless control system for F-W PCS

Table 1: PID controller parameters using Z-N method

Controller	K_P	K_I	K_D
P	0.0039	0	0
PD	0.04	0	0.002
PID	0.05	0.026	0.025

SECTION 7.

Conclusions

The main point that we can conclude, is that the feedback control system is feasible when it is implemented over wireless sensor network to connect both the plant and the controller remotely. The PID parameters can be tuned when the packet loss and delay of the wireless network is induced which can eventually affect the system performance and stability.

The client-server scheme is built using the MATLAB blocks and it has proved to be efficient in implementing the control strategy and plant interfacing with a NI-6008 card.

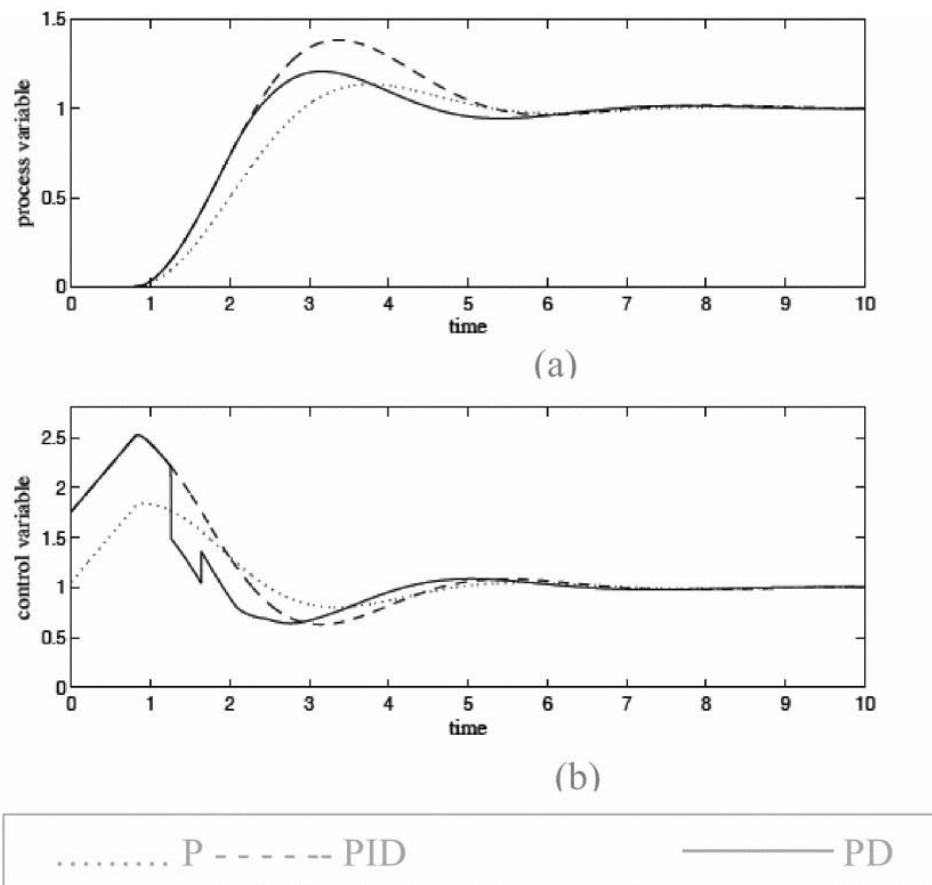

Fig. 11: Simulation results for F-W PCS model with three types of PID controller listed in Table 1 (a) step response and (b) control signal.

ACKNOWLEDGMENT

The authors would like to express their thanks to the control engineering group at the Dept. of the Computer Science Electrical and Space Engineering at Lulea university of Technology especially Dr. George Nikolakopoulos, Dariuch Kominiak, Thaker Nayl and Khalid Atta for their help and support.

References

1. F-W Wang, D. Liu, "Networked controlled systems: Theory and applications" in , London:Springer-Verlag, 2008.
2. S. Mazumder, "Wireless networking based control" in , Springer, 2011.
3. J. Hespanha, P. Naghshtabrizi, Y. Xu, "A survey on recent results in networked control systems", *proceedings of IEEE*, vol. 95, no. 1, 2007.
4. "Innovative applications for wireless control and tele-metry", 2013, [online]Available: www.remotecontroltech.com.
5. A. Nayak, I. Stojmenovic, "Wireless sensor and actuator networks", *John-Whiley & sons*, 2010.
6. S. Zampieri, "Trends in networked control systems", *the Proceedings of the 17th World Congress International Federation of Automatic Control Korea*, 2008.
7. G. Nikolakopoulos, "Lecture notes on industrial automation and process control", *Department of Computer Science Electrical and Space Engineering LTU Sweden*, 2013.
8. G. Nikolakopoulos, A. Panousopoulou, A. Tsez, J. Lygros, "Multi-hopping induced gain scheduling for wireless networked control systems", *the Asian Journal of Control*, vol. 9, no. 4, pp. 450-457, Dec. 2007.
9. L. Dritsas, G. Nikolakopoulos, A. Tzes, "On the modelling of networked control systems", *the Proceedings of the Mediterranean Conference on Control and Automation Greece*, 2007.
10. G. Nikolakopoulos, A. Panousopoulou, A. Tsez, "Experimental controller tuning and QoS optimization of a wireless transmission scheme for real-time remote control applications", *the Elsevier*, pp. 333-346, 2008.
11. Y. Uchimura, "Wireless network based identification and control with variable time delay", *the IEEE Proceedings*, pp. 336-341, 2008.
12. Amaraward Hana et al., "Case study of WSN as a replacement for SCADA", *the 4th International Conference on Industrial and Information Systems (ICIIS)*, pp. 49-54, Dec., 2009.
13. G. Nikolakopoulos, K. Alexis, I. Arvanitakis, A. Tsez, "A collaborative unmanned helicopter control strategy for image compression and wireless transmission", *the 81th Mediterranean Conference on Control and Automation*, pp. 1206-1211, 2010.
14. X. Li, S. Munigalas, Q. Zeng, "Design and implementation of a wireless programmable logic controller system", *the International Conference on Electrical and Control Engineering*, pp. 3138-3141, 2010.
15. A. Bemporad, S. Di Cairano, E. Henrikson, K. Johanson, "Hybrid model predictive control based on wireless sensor feedback an experimental study", *the International Journal of Robust and Nonlinear Control*, pp. 209-225, 2010.
16. O. Kaltiokallio, M. Eriksson, M. Bocca, "On the performance of the PIDPLUS controller in wireless control systems", *the 18th Mediterranean Conference on Control Automation*, pp. 707-714, 2010.
17. P. Park, J. Araujo, K. Johanson, "Wireless networked control system: co-design", *International Conference on Networking Sensing and Control Netherland*, 2011.
18. M. Lemmon, X. Hu, "Almost sure stability of wireless networked control systems under exponentially bursts of drop-outs" in *HSCC'11, USA*, pp. 12-14, 2011.

19. R. Choi, S. Lee, D. Lee, L. Yoo, "Packet loss compensation for cyber-physical control systems", *IEEE/ACM Third International Conference on Cyber-physical Systems*, 2012.
20. F. Qu, Z. Guan, F. Yauan, X. Zhan, "Stabilization of wireless networked control systems with packet loss and impulse disturbance", *the Proceedings of 10th World Congress of Intelligent Control and Automation*, pp. 1031-1036, July, 2012.
21. A. Ulusoy, A. Onat, O. Gurbuz, "Wireless model predictive networked control system over IEEE802.15.4", *the 2013 IEEE International Conference on Distributed Computing Sensor Systems*, pp. 382-387, 2013.
22. S. Dai, H. Lin, S. Ge, "A switched system approach to scheduling of networked control systems with communication constraints", *the 48th IEEE Conference on Decision and Control*, pp. 4991-4996, Dec. 2009.
23. X. Cao, Y. Chen, Y. Xiao, Y. Sun, "Control system design for wireless sensor and actuator networks", *IEEE Communication Society Proceedings*, 2008.