

NASA Technical Paper 1126

Cold-Air Performance of  
a Tip Turbine Designed  
To Drive a Lift Fan

IV - Effect of Reducing  
Rotor Tip Clearance

Jeffrey E. Haas, Milton G. Kofskey,  
and Glen M. Hotz

JANUARY 1978

**NASA**

NASA Technical Paper 1126

# Cold-Air Performance of a Tip Turbine Designed To Drive a Lift Fan

## IV - Effect of Reducing Rotor Tip Clearance

Jeffrey E. Haas

Propulsion Laboratory

U.S. Army R&T Laboratories (AVRADCOM)

Milton G. Kofskey and Glen M. Hotz

Lewis Research Center

Cleveland, Ohio



National Aeronautics  
and Space Administration

**Scientific and Technical  
Information Office**

1978

# COLD-AIR PERFORMANCE OF A TIP TURBINE DESIGNED TO DRIVE A LIFT FAN

## IV - EFFECT OF REDUCING ROTOR TIP CLEARANCE

by Jeffrey E. Haas\*, Milton G. Kofskey, and Glen M. Hotz

Lewis Research Center

### SUMMARY

Performance was obtained over a range of speeds and pressure ratios for a 0.4 linear scale version of the LF460 lift fan turbine with the rotor radial tip clearance reduced to about 2.5 percent of the rotor blade height. These tests covered a range of speeds from 60 to 140 percent of design equivalent speed and a range of scroll inlet total to diffuser exit static pressure ratios from 2.6 to 4.2.

The results of the investigation showed that reducing the rotor tip clearance from 25 to 2.5 percent of the rotor blade height resulted in an increase in total efficiency from 0.815 to 0.861. This represents a 5.6 percent increase.

A mass flow of 3.326 kilograms per second was obtained at design equivalent speed and pressure ratio. This mass flow was nearly identical to that obtained with the original tip clearance configuration.

Good agreement was obtained between the tip clearance loss for the subject turbine and the loss predicted from a reference tip clearance investigation.

### INTRODUCTION

An experimental program was conducted at the NASA Lewis Research Center to investigate the aerodynamic performance of a 0.4 linear scale version of the LF460 lift fan turbine. The LF460 lift fan system was designed to be used in a V/STOL transport aircraft to provide takeoff and landing lift. In this lift fan system a fan is driven by a turbine which is mounted on the rotating shroud of the fan blades. Such a turbine is called a tip turbine and is supplied by one or more remotely located gas generators.

To obtain detailed performance data for this tip turbine, four series of tests were conducted using a solid disk in place of the fan. The first series was general perfor-

---

\* Propulsion Laboratory, U. S. Army R&T Laboratories (AVRADCOM).

mance tests, the results of which are presented in reference 1. The second series consisted of partial admission tests with one side of the scroll used at a time to simulate the loss of one of the gas generators. These results are presented in reference 2. The third series investigated the effect of simulated fan leakage on turbine performance. The results from this part of the program are presented in reference 3.

The fourth and final series of tests, which is the subject of this report, investigated the effect on turbine performance of reducing the rotor radial tip clearance. In reference 1 the rotor clearances were scaled to match the calculated hot running clearances of the full-size turbine. Because large axial and radial clearances were required as a result of large thermal growth of the scroll structure and considerable fan flexure, the rotor tip clearance was approximately 25 percent of the rotor blade height.

In this investigation, the rotor tip clearance was decreased from about 25 percent to about 2.5 percent of the rotor blade height by placing an insert in the turbine casing above the rotor blades. Even though a 2.5 percent tip clearance would not be a practical operating tip clearance for the LF460 turbine, an advanced lift fan system is being designed with this level of turbine rotor tip clearance. Therefore, this investigation was conducted to provide an indication of the efficiency gain due to operating with a much smaller tip clearance.

Performance tests were conducted with air entering the scroll at total conditions of approximately 320 K and 9.10 newtons per square centimeter. The speed range covered was 60 to 140 percent of the design equivalent speed in increments of 20 percent. At each speed increment the total to static pressure ratio, as based on the scroll inlet total pressure and the diffuser exit static pressure, was varied from approximately 2.6 to 4.2.

In this report, results are presented as curves relating equivalent mass flow, equivalent torque, equivalent specific work, and efficiency with pressure ratio. A comparison is made with the results obtained for the original tip clearance configuration (ref. 1). In addition, the results from a reference tip clearance investigation are used to predict a tip clearance loss for the subject turbine.

## SYMBOLS

$\Delta h$	turbine specific work, J/g
N	rotative speed, rpm
p	absolute pressure, N/cm <sup>2</sup>
$R_x$	blade reaction, $(W_5^2 - W_4^2)/2 \Delta h$

T	absolute temperature, K
U	blade velocity, m/sec
V	absolute gas velocity, m/sec
$\Delta V_u$	change in absolute tangential velocity, m/sec
W	change in absolute tangential velocity, m/sec
w	mass flow, kg/sec
$\alpha$	absolute gas flow angle measured from axial direction, deg
$\beta$	relative gas flow angle measured from axial direction, deg
$\Gamma$	torque, N-m
$\gamma$	ratio of specific heats
$\delta$	ratio of stator inlet total pressure to U. S. standard sea-level pressure, $p'_3/p^*$
$\epsilon$	function of $\gamma$ used in relating parameters to those using air inlet conditions at U. S. standard sea-level conditions, $(0.740/\gamma)[(\gamma + 1)/2]^{\gamma/(\gamma-1)}$
$\eta$	efficiency based on total to static pressure ratio, $p'_3/p_5$
$\eta'$	efficiency based on total pressure ratio, $p'_3/p'_5$
$\theta_{cr}$	squared ratio of critical velocity at stator inlet temperature to critical velocity at U. S. standard sea-level temperature, $(v_{cr3}/v_{cr}^*)^2$
$\omega$	turbine speed, rad/sec

#### Subscripts:

cr	critical corresponding to Mach number at unity
eq	equivalent
1	station at scroll inlet (fig. 12)
3	station at stator inlet (fig. 12)
4	station at stator exit (fig. 12)
5	station at rotor exit (fig. 12)
6	station at diffuser exit (fig. 12)

#### Superscripts:

'	absolute total state
*	U. S. standard sea-level conditions (temperature, 288.16 K; pressure, 10.13 N/cm <sup>2</sup> )

## TURBINE DESCRIPTION

A brief description of the full-scale turbine is given first, followed by a description of the scale-model turbine. Engine design conditions for the full-scale turbine are presented in table I along with the design equivalent conditions for the scaled turbine.

### Full-Scale Turbine

The full-scale turbine was designed to drive a lift-fan having a nominal tip diameter of 152.4 centimeters. Figure 1 (from ref. 4) presents the basic layout of the fan and drive turbine. There are two inlets to the scroll which are located adjacent to each other. Each inlet is supplied by a separate gas generator and, in turn, each inlet supplies a different  $180^\circ$  segment of the scroll. The purpose of the dual inlets is for redundancy in case one of the gas generators fails. The use of dual inlets results in an airflow direction which is the same as the direction of rotor rotation in half of the scroll, and an airflow direction which is in a direction opposite to the direction of rotor rotation in the other half of the scroll.

Figure 1 shows axial and radial clearances in the turbine that are large compared to a conventional turbine design. These unusually large clearances are the result of large thermal growth of the scroll structure, and they provide for considerable flexure of the fan. A three-chamber scroll was used to distribute the hot gas in the stator and to form a compact, structurally sound design. The lift-fan system was designed to be compact so that it could be enclosed within the envelope of the wing cross section.

A turbine exit diffuser was used to produce as low a static pressure as possible in the turbine rotor to prevent the leakage of hot turbine gas into the fan.

Figure 2 shows the design mean-section velocity diagrams for the turbine. As discussed in reference 4, the turbine was a single-stage design with a supersonic stator and a subsonic, zero static pressure drop rotor. The turbine rotor had a hub to tip radius ratio of about 0.94. Both the stator and rotor blading were of constant section design.

Since the flow in one-half of the scroll moves counter to the direction of rotation, three different vane profiles are used to meet the varying flow angles created by the scroll. Figure 3 shows the different vane types and how these vanes are located circumferentially with respect to the scroll. The vane profiles were designed for inlet flow angles of  $60^\circ$ ,  $0^\circ$ , and  $-60^\circ$ . However, the diverging portions of the passages were geometrically similar for all three types of vanes. The vanes were designed with a convergent-divergent flow passage which resulted in an exit to throat area ratio of 1.071. There were 157 vanes.

Figure 4 shows the rotor blade profile. There were 264 rotor blades. The rotor profile is constant from hub to tip. The rotor was designed to operate at impulse conditions to minimize the tip leakage losses. As mentioned previously, large axial and radial clearances are associated with fan flexure and shroud growth. The tip clearance was of the order of 1.3 centimeters, which is approximately 25 percent of the rotor blade height. Thus, impulse blading with shrouded blade tips was chosen to minimize the tip leakage losses.

### Scale-Model Turbine

In order to test the LF460 turbine in an existing Lewis Research Center cold air component test facility, it was necessary to design and fabricate a 0.4 linear scale model of this turbine. Figure 5 is a photograph of the scaled turbine installed in the test cell. The photograph, which was taken from the exhaust end, shows the inlet and exhaust piping and the scroll assembly.

Figure 6 is a closeup of the scroll and stator assembly on its mounting stand. The trailing edges of some of the stator vanes can be seen in this figure.

The rotor is shown in figure 7. The rotor disk and blading were machined from a single forging, and a shroud ring was furnace brazed to the blade tips. As discussed in the INTRODUCTION, the axial and radial tip clearances were scaled from the hot operating condition for the full-scale turbine.

### APPARATUS

The apparatus consisted of the turbine, a cradled gearbox, and a cradled dynamometer to absorb the power output of the turbine and to control turbine speed. In addition, there was inlet and exhaust piping with flow controls for setting inlet and exit pressures of the turbine. The arrangement of the apparatus is shown schematically in figure 8. High-pressure dry air was supplied from a central air system. The air passed through a 100-kilowatt heater, a calibrated orifice plate, and a remotely controlled turbine inlet valve. Leaving the turbine the air was exhausted through a system of piping and a remotely operated valve into a central low-pressure exhaust system. A 224-kilowatt dynamometer cradled on hydrostatic trunion bearings was used to absorb the turbine power, to control the turbine speed, and to measure the torque. The dynamometer was coupled to the turbine shafting through a gearbox cradled on hydrostatic bearings. The gearbox provided relative rotative speeds between dynamometer and turbine of 1.0 to 2.0. The stators of the gearbox and dynamometer were coupled

together so that the measured torque was the net torque developed by the turbine. Figure 9 shows the dynamometer and gearbox.

## INSTRUMENTATION

A torque arm attached to the dynamometer stator and a commercial strain-gage load cell were used to measure the net turbine torque. The load cell output was read on a digital voltmeter. The rotational speed was detected by a magnetic pickup and shaft-mounted gear. The magnetic pickup output was converted to a direct-current voltage which was proportional to the frequency and fed into the digital voltmeter.

State conditions of the flow were determined by measurements taken at the scroll inlet, stator inlet, stator exit, rotor exit, and diffuser exit. The instrumentation stations are shown in figure 10. The instrumentation at the scroll inlet (station 1) included four static pressure taps in each of the two inlets. A total-temperature rake containing three thermocouples was also located upstream of the two inlets. At the stator inlet (station 3) there were six static pressure taps equally spaced circumferentially along the hub wall. There were also six total pressure probes equally spaced circumferentially around the turbine. Each total pressure probe contained three elements to provide measurements at the mean radius and also near the hub and tip walls. In addition, there was a tube on each side of the mean-section total pressure sensing tube. These two side tubes had their sensing ends cut off to form a  $90^\circ$  wedge and were connected to a differential pressure transducer to provide a means for manually aligning the probe with the flow. A scale and pointer were attached to each probe to provide an indication of the mean-section flow angle. At the stator exit (station 4) a static pressure measurement by the rotor disk was assumed to represent the stator exit static pressure.

At the rotor exit (station 5) there were 12 single-element Kiel total pressure probes approximately evenly spaced circumferentially. Radially these probes were spaced so that there were two each at approximately 5, 20, 40, 60, 80, and 95 percent of the rotor blade height. Use of Kiel type total pressure probes provided accurate total pressure readings over a range of absolute flow angle of about  $\pm 30^\circ$ .

At the diffuser exit (station 6) there were eight static pressure taps equally spaced circumferentially with four each at the inner and outer walls. Two self-aligning probes, located  $180^\circ$  apart at the mean radius, were used for measuring total pressure, total temperature, and flow angle.



## PROCEDURE

In this tip clearance investigation, the rotor tip clearance was decreased from about 25 percent to about 2.5 percent of the rotor blade height by placing an insert in the turbine casing above the rotor blades. Figure 11 shows a schematic of the original and reduced tip clearance configurations.

A dynamometer-torque calibration was obtained before each daily series of runs. Corrections were applied to the measured net turbine torque to include the effects of calculated disk windage and measured turbine bearing friction to obtain the turbine aerodynamic torque. At design conditions, these corrections amounted to about 1 percent of the measured turbine power.

The total efficiency  $\eta'$  was based on stator inlet total pressure and rotor exit total pressure. The stator inlet and rotor exit total pressures were an average of the respective measured values. At the scroll inlet, total pressure was calculated from mass flow, total temperature, static pressure, and flow angle. The rotor exit total temperature was calculated from the measured scroll inlet total temperature and the turbine specific work. When calculating the scroll inlet total pressure, the flow angle was assumed to be zero.

## RESULTS AND DISCUSSION

Performance results are presented for a 0.4 linear scale version of the LF460 lift fan turbine having a reduced level of rotor tip clearance. Performance tests were conducted at nominal scroll inlet total conditions of 320 K and 9.10 newtons per square centimeter. The range of speeds covered was 60 to 140 percent of design equivalent speed, and the range of scroll inlet total to diffuser exit static pressure ratio  $p'_1/p_6$  was approximately 2.6 to 4.2. Experimental results include performance in terms of equivalent mass flow, equivalent torque, equivalent specific work, and efficiency. A comparison is made with the results obtained for the original tip clearance configuration (ref. 1).

In addition, the results from reference 5 were used to predict a tip clearance loss for the subject turbine.

### Mass Flow

Figure 12 shows the variation of equivalent mass flow  $\epsilon w \sqrt{\theta_{cr}} / \delta$  with total pressure ratio  $p'_3/p'_5$ . This figure indicates that the stator was choked over the range of speeds and pressure ratios investigated. The equivalent choking mass flow was

3.326 kilograms per second, which was about 0.30 percent smaller than that obtained for the original tip clearance configuration (ref. 1). This difference was considered to be well within the range of experimental error. Since the stator was choked, reducing the rotor tip clearance was not expected to affect the choking mass flow.

### Torque

Figure 13 shows the variation of equivalent torque  $\epsilon\Gamma/\delta$  with total pressure ratio  $p'_3/p'_5$  for lines of constant speed. An equivalent torque of 413 newton-meters was obtained at equivalent design speed and pressure ratio. This value was about 5.4 percent larger than that obtained for the original tip clearance configuration. Considering the percent changes in torque and mass flow between the two tip clearance configurations, it was apparent that the efficiency for the reduced tip clearance configuration was about 5.6 percent larger than the efficiency for the original tip clearance configuration. The torque curves show a continuous increase with pressure ratio, indicating that limiting loading was not achieved.

### Performance Map and Calculated Turbine Velocity Diagrams

A performance map for the reduced tip clearance configuration is shown with figure 14. This performance map is based on the total pressure ratio from the stator inlet to the rotor exit. The map shows equivalent specific work  $\Delta h/\theta_{cr}$  as a function of mass flow speed parameter  $\epsilon w\omega/\delta$  for the various equivalent speeds investigated. Lines of constant pressure ratio  $p'_3/p'_5$  and efficiency  $\eta'$  are superimposed. An efficiency of 0.861 was obtained at design equivalent speed and pressure ratio. This efficiency was about 5.6 percent greater than the efficiency of 0.815 obtained for the original tip clearance configuration.

Figure 15 shows a performance map for the original tip clearance configuration. This performance map is presented in reference 1. A comparison of the performance maps for the two configurations shows that the island of peak efficiency for the reduced tip clearance configuration shifted to a lower speed and pressure ratio. In addition, over the range of speed and pressure ratio investigated, the improvement in efficiency for the reduced tip clearance configuration was between approximately 3 to 6 percentage points.

Figure 16 shows turbine velocity diagrams as calculated from experimental data at design equivalent speed and pressure ratio. These velocity diagrams were calculated based on mass-averaged conditions across the turbine. The velocity diagrams were constructed from the experimentally determined values of mass flow, torque,

speed, stator inlet total pressure and total temperature, and rotor exit total pressure. In addition, two assumptions were used. The first assumption was specifying a value of 4.8 percent for the stator total pressure loss. This loss was the same as for the original tip clearance configuration. The second assumption was using a static pressure on the upstream side of the rotor disk to represent the stator exit static pressure.

The experimental velocity diagrams for the original tip clearance configuration is shown in figure 17. This figure is also presented in reference 1. A comparison of figures 16 and 17 shows that the reduced tip clearance configuration had more rotor reaction and more whirl at the rotor exit than the original tip clearance configuration. Both trends were consistent with results obtained from other tip clearance investigations.

Values of rotor reaction  $R_x$  and rotor incidence angle were calculated for the reduced tip clearance configuration using the velocity diagrams of figure 16. The rotor reaction and incidence angle were 0.144 and  $2.4^\circ$ , respectively, compared to -0.031 and  $1.9^\circ$  for the original tip clearance configuration.

In addition, values of stator and rotor efficiency were calculated from the experimental velocity diagrams for the reduced tip clearance configuration. The stator efficiency was 0.963. The stator efficiency is defined as the ratio of the actual stator exit kinetic energy to the ideal stator exit kinetic energy, which is a function of the stator inlet total to stator exit static pressure ratio. The rotor efficiency was 0.894. The rotor efficiency is defined as the ratio of the actual turbine work to the ideal turbine work, which is a function of the rotor inlet absolute total to rotor exit absolute total pressure ratio. For the original tip clearance configuration the stator and rotor efficiencies were 0.967 and 0.847, respectively.

### Comparison of Predicted and Experimental Tip Clearance Loss

To predict the tip clearance loss for the subject turbine, the experimental results from reference 5 were used. The reference 5 turbine was also designed with a shrouded impulse rotor. Figure 18 shows the results from the subject and reference investigations. The tip clearance loss comparison was made on the basis of static efficiency  $\eta$  since this was the only efficiency reported in reference 5. For the subject turbine the static efficiencies were 0.687 and 0.726 for the original and reduced tip clearance configurations, respectively. Thus, the percentage increase in static efficiency was about 5.7, which was nearly identical to the percentage increase in total efficiency.

Figure 18 indicates that the tip clearance loss for the reference 5 turbine amounted to about a 0.30 percent decrease in efficiency for a 1 percent increase in

tip clearance. For the subject turbine the tip clearance loss amounted to about a 0.25 percent decrease in efficiency for a 1 percent increase in tip clearance. Thus, the actual tip clearance loss was close to the predicted value.

#### SUMMARY OF RESULTS

Performance was obtained over a range of speeds and pressure ratios for a 0.4 linear scale version of the LF460 lift fan turbine with the rotor radial tip clearance reduced to about 2.5 percent of the rotor blade height. The results of this investigation may be summarized as follows:

1. Reducing the rotor tip clearance from 25 to 2.5 percent of the rotor blade height resulted in an increase in total efficiency from 0.815 to 0.861. This represented a 5.6 percent increase.
2. A mass flow of 3.326 kilograms per second was obtained at design equivalent speed and pressure ratio. This mass flow was nearly identical to that obtained with the original tip clearance configuration.
3. Good agreement was obtained between the tip clearance loss for the subject turbine and the loss predicted from a reference tip clearance investigation.

Lewis Research Center,  
National Aeronautics and Space Administration,  
Cleveland, Ohio, September 15, 1977,  
505-05.

#### REFERENCES

1. Haas, Jeffrey E.; et al.: Cold-Air Performance of a Tip Turbine Designed to Drive a Lift Fan. I - Baseline Performance. NASA TM X-3452, 1976.
2. Haas, Jeffrey E.; et al.: Cold-Air Performance of a Tip Turbine Designed to Drive a Lift Fan. II - Partial Admission. NASA TM X-3481, 1977.
3. Haas, Jeffrey E.; et al.: Cold-Air Performance of a Tip Turbine Designed to Drive a Lift Fan. III - Effect of Simulated Fan Leakage on Turbine Performance. NASA TP-1109, 1977.
4. LF460 Detail Design. (71-AEG-297, General Electric Co.; NASA Contract NAS2-6056.) NASA CR-120787, 1971.

5. Kofskey, Milton G. : Experimental Investigation of Three Tip-Clearance Configurations Over a Range of Tip Clearance Using a Single-Stage Turbine of High Hub-to-Tip Radius Ratio. NASA TM X-472, 1961.

TABLE I. - TURBINE DESIGN CONDITIONS

Parameter	Full-scale engine	Scale-model equivalent
Stator inlet temperature, $T_3'$ , K	1144	288.2
Stator inlet pressure, $p_3'$ , N/cm <sup>2</sup>	37.7	10.13
Mass flow rate, $w$ , kg/sec	34.6	3.03
Rotative speed, $N$ , rpm	4300	5395
Specific work, $\Delta h$ , J/g	268.4	67.6
Torque, $\Gamma$ , N-m	20623	363
Power, kW	9290	205
Pressure ratio, $p_3'/p_5'$	3.05	3.16
Pressure ratio, $p_1'/p_6$	3.92	4.10
Total efficiency, $\eta_{3-5}$	0.832	0.832
Work factor, $\Delta V_u/U$	1.982	1.982

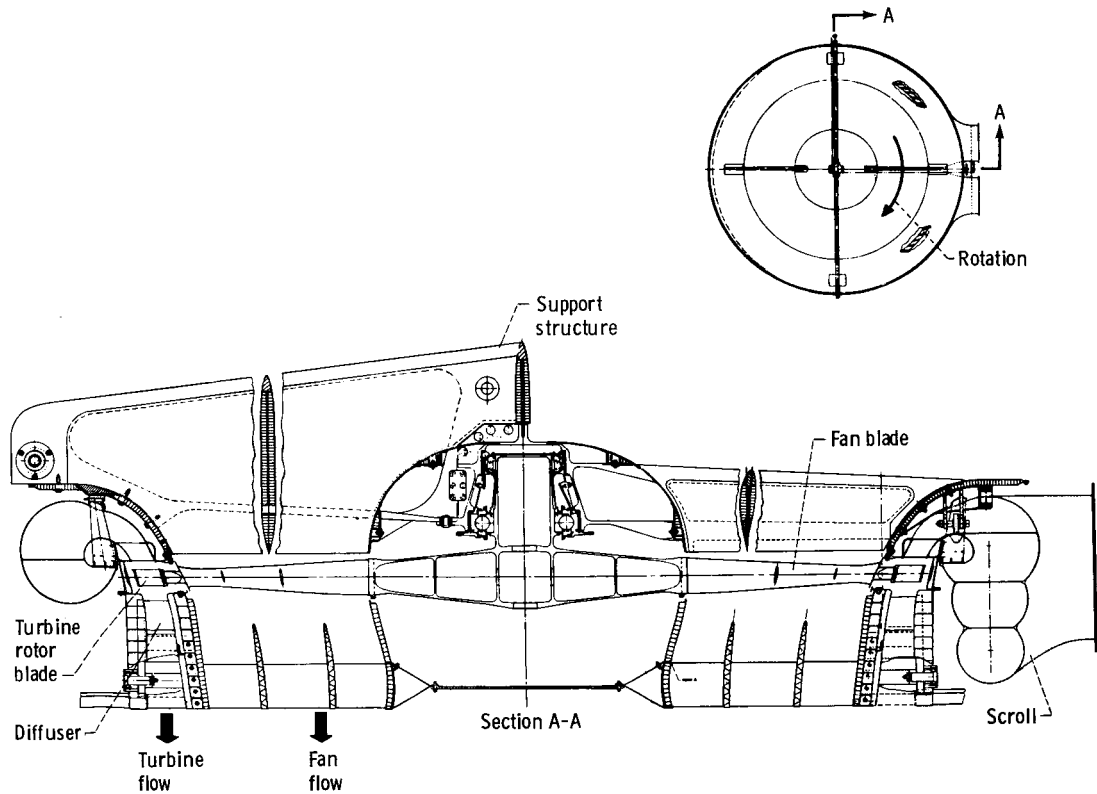

Figure 1. - Lift-fan assembly.

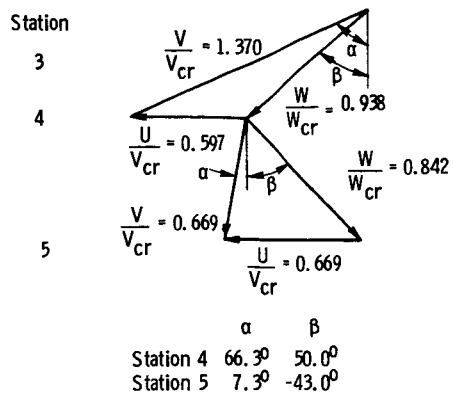

Figure 2. - Design velocity diagrams for LF460 turbine at mean section.

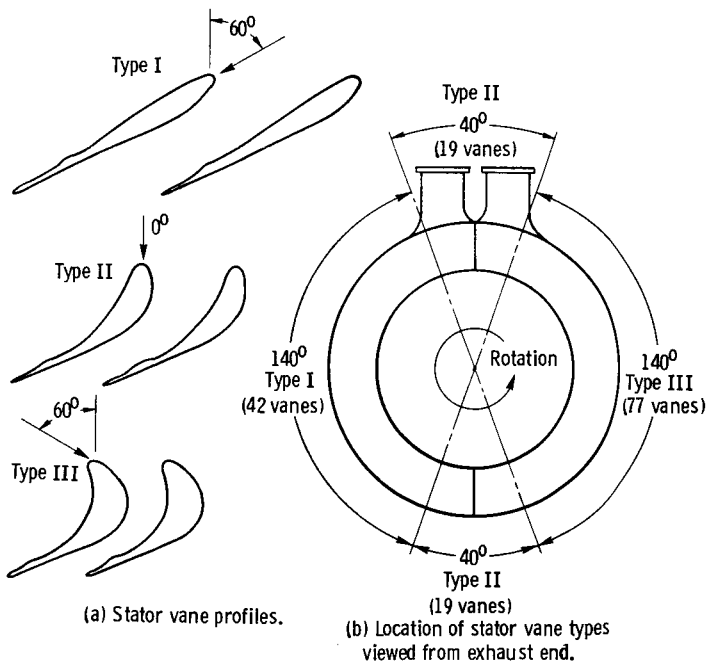

Figure 3. - Stator vane profiles and locations.

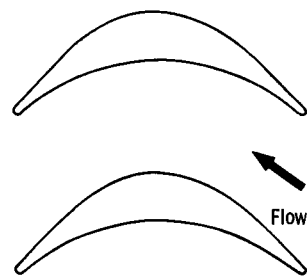
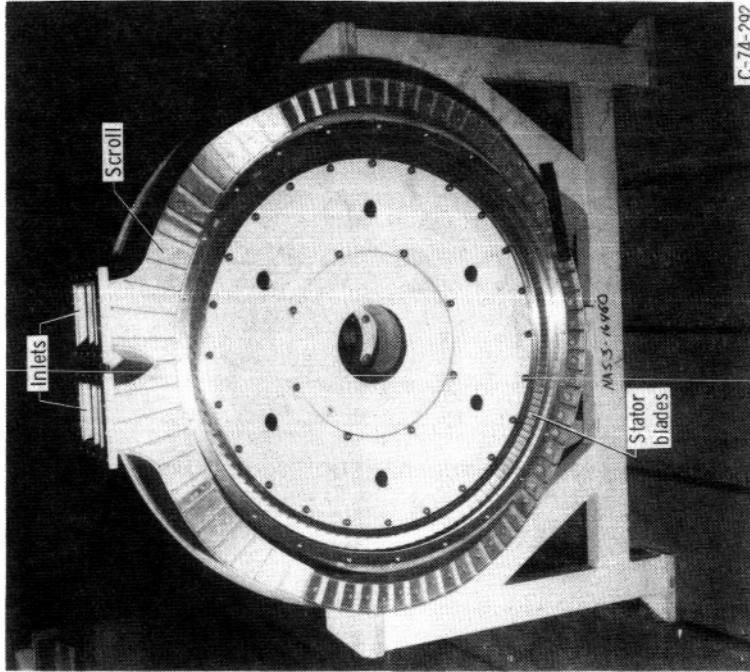
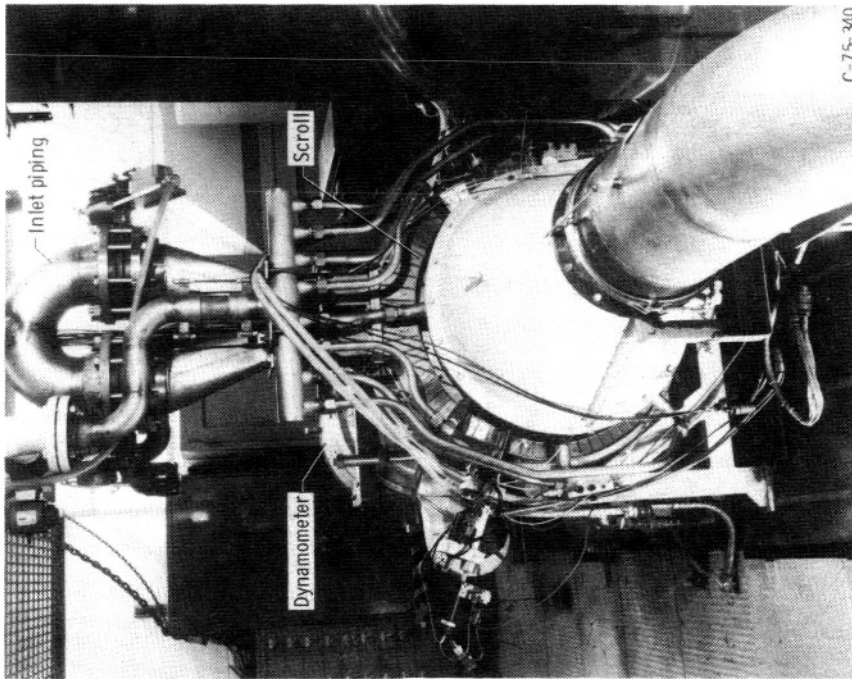

Figure 4. - Rotor blade profile.



C-74-292

Figure 6. - Test scroll and stator.



C-75-240

Figure 5. - Turbine test installation.



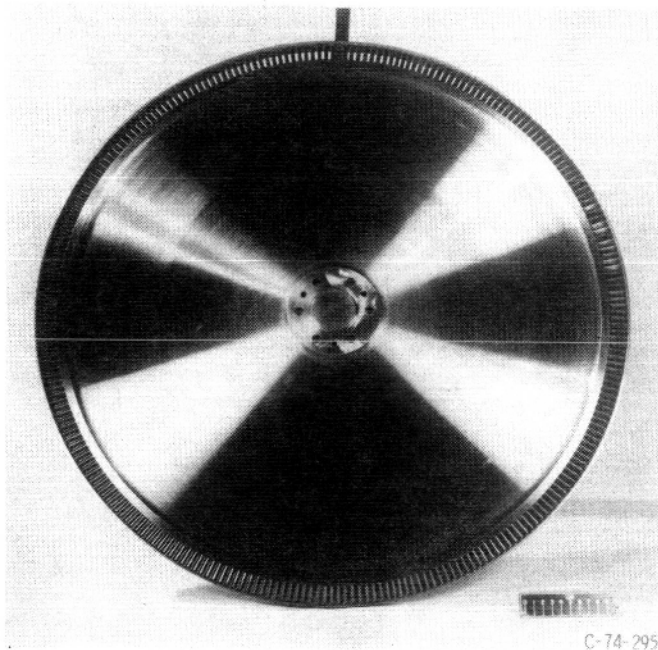

Figure 7. - Test rotor.

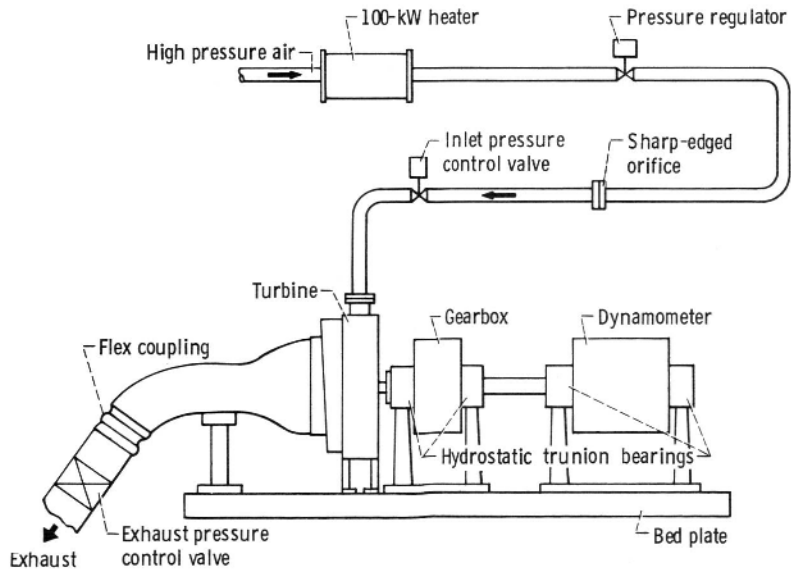

Figure 8. - Test installation diagram.

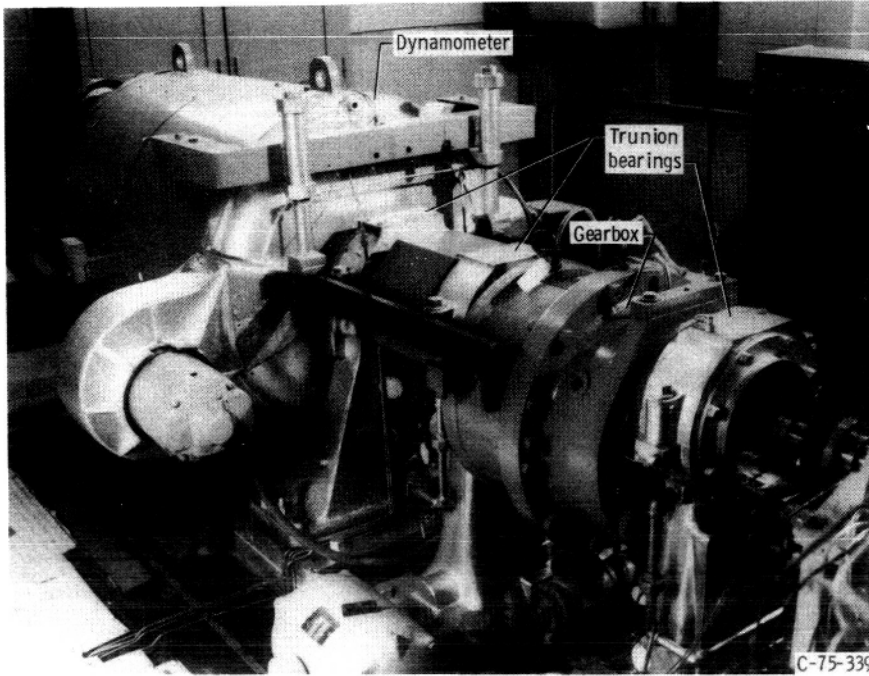

Figure 9. - Dynamometer and gearbox.

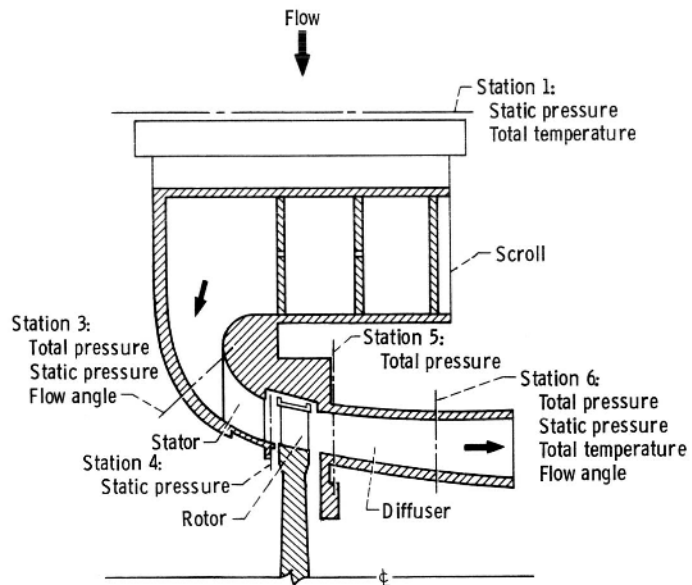
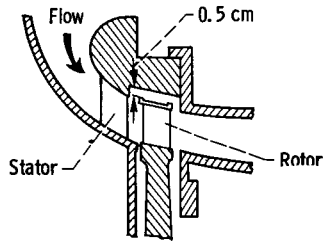
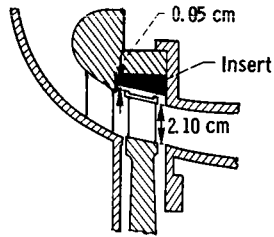

Figure 10. - Schematic of turbine.



a) Original tip clearance configuration.



(b) Reduced tip clearance configuration.

Figure 11. - Schematics of original and reduced tip clearance configurations.

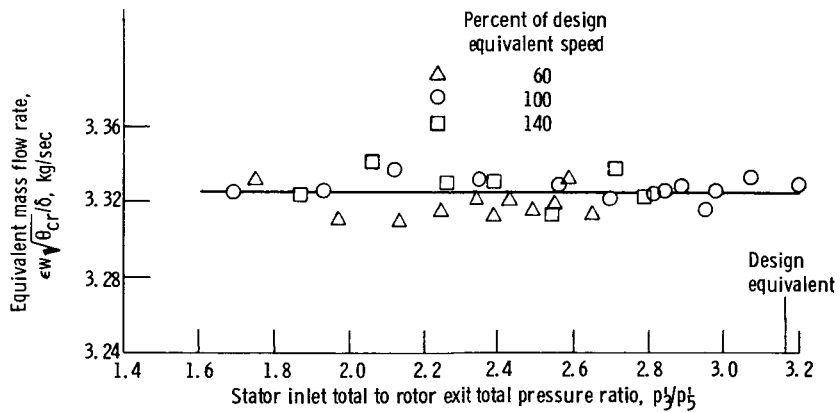

Figure 12. - Variation of mass flow rate with pressure ratio for reduced tip clearance configuration.

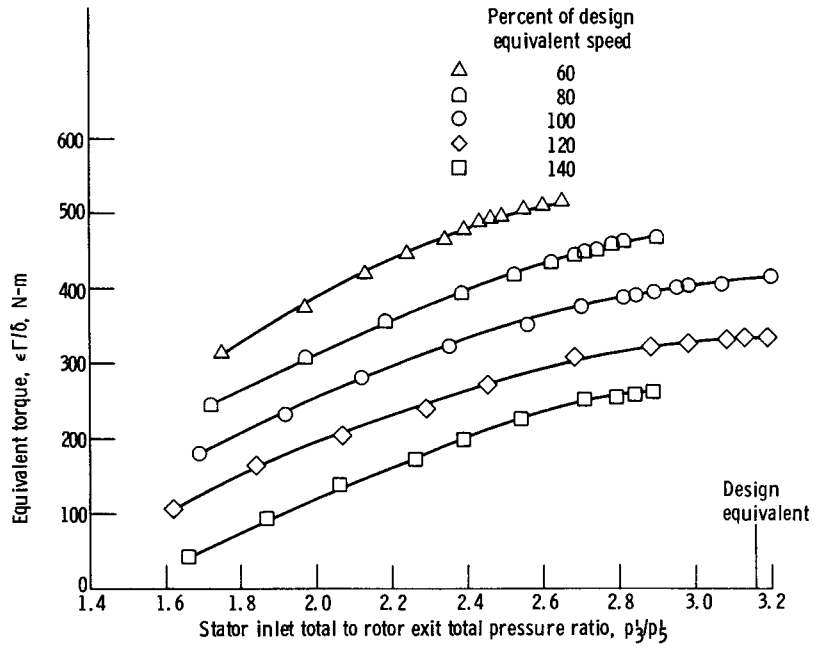

Figure 13. - Variation of torque with pressure ratio for reduced tip clearance configuration.

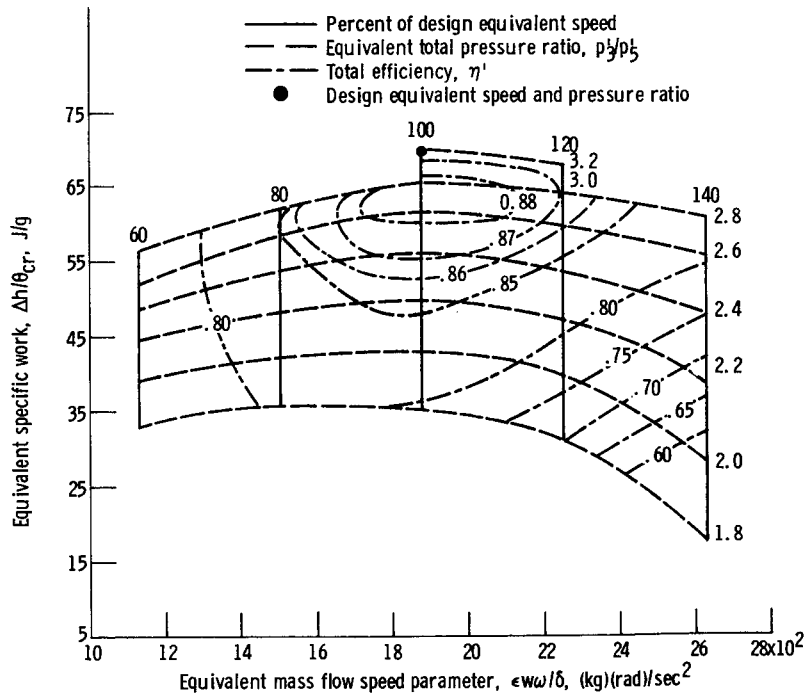

Figure 14. - Performance map based on stator inlet to rotor exit total pressure ratio for reduced tip clearance configuration.

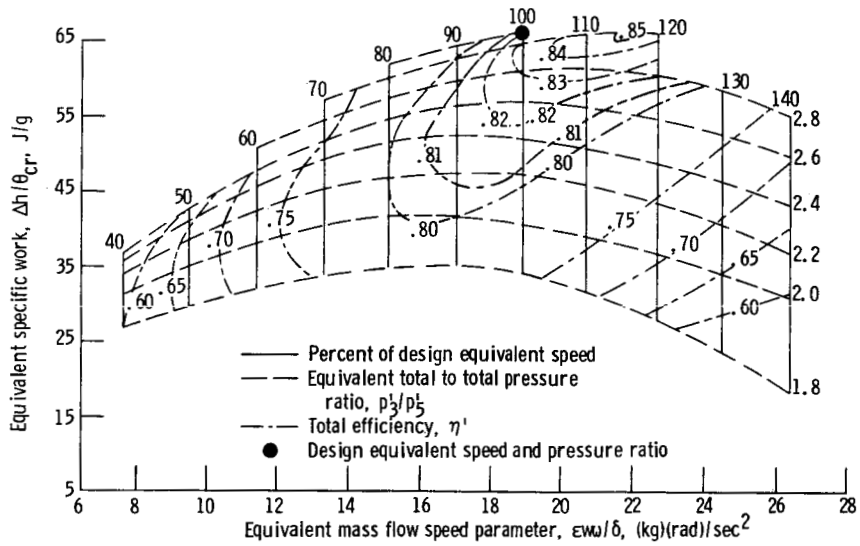

Figure 15. - Performance map based on stator inlet to rotor exit total pressure ratio for the original tip clearance configuration (from ref. 1).

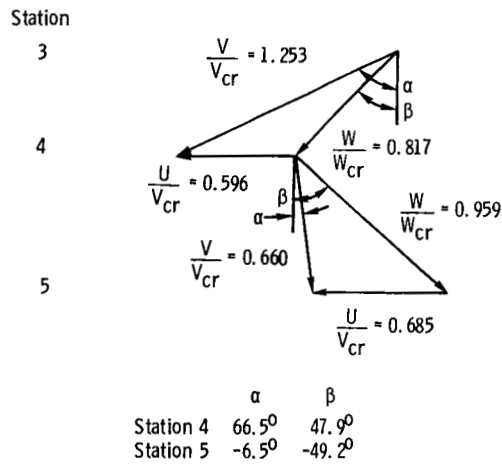

Figure 16. - Velocity diagrams for reduced tip clearance configuration as calculated from experimental results at design equivalent speed and design total pressure ratio.

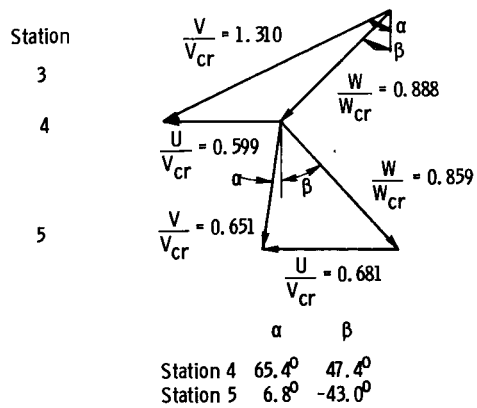

Figure 17. - Velocity diagrams for the original tip clearance configuration as calculated from experimental results at design equivalent speed and design total pressure ratio (from ref. 1).

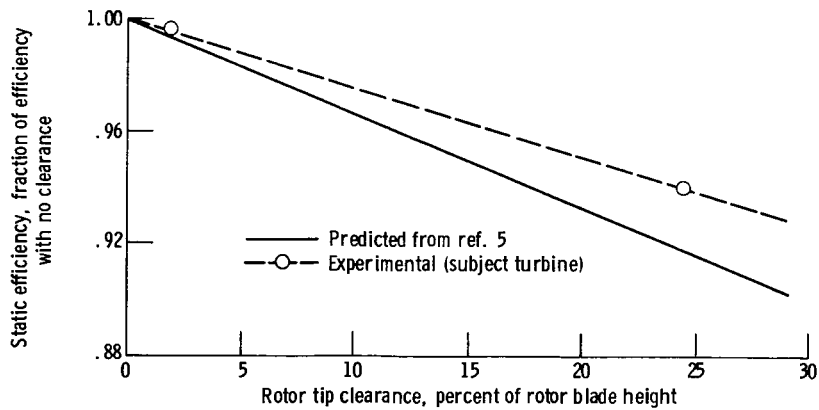

Figure 18. - Comparison of predicted and experimental tip clearance loss between original and reduced tip clearance configurations.

1. Report No. TP-1126	2. Government Accession No.	3. Recipient's Catalog No.	
4. Title and Subtitle <b>COLD-AIR PERFORMANCE OF A TIP TURBINE DESIGNED TO DRIVE A LIFT FAN IV - EFFECT OF REDUCING ROTOR TIP CLEARANCE</b>		5. Report Date January 1978	6. Performing Organization Code
		8. Performing Organization Report No. <b>E-9293</b>	10. Work Unit No. <b>505-05</b>
7. Author(s) Jeffrey E. Haas, Milton G. Kofskey, and Glen M. Hotz		11. Contract or Grant No.	
9. Performing Organization Name and Address NASA Lewis Research Center and Propulsion Laboratory U.S. Army R&T Laboratories (AVRADCOM) Cleveland, Ohio 44135		13. Type of Report and Period Covered <b>Technical Paper</b>	
		14. Sponsoring Agency Code	
12. Sponsoring Agency Name and Address National Aeronautics and Space Administration Washington, D. C. 20546		15. Supplementary Notes	
16. Abstract Performance was obtained over a range of speeds and pressure ratios for a 0.4 linear scale version of the LF460 lift fan turbine with the rotor radial tip clearance reduced to about 2.5 percent of the rotor blade height. These tests covered a range of speeds from 60 to 140 percent of design equivalent speed and a range of scroll inlet total to diffuser exit static pressure ratios from 2.6 to 4.2. Results are presented in terms of equivalent mass flow, equivalent torque, equivalent specific work, and efficiency.			
17. Key Words (Suggested by Author(s)) Tip turbine; Lift fan turbine; Aerodynamic performance; Tip clearance; VTOL aircraft; STOL aircraft		18. Distribution Statement Unclassified - unlimited STAR Category 02	
19. Security Classif. (of this report) Unclassified	20. Security Classif. (of this page) Unclassified	21. No. of Pages 21	22. Price* A02

\* For sale by the National Technical Information Service, Springfield, Virginia 22161