

Combustion Characteristics of Gas Turbine Alternative Fuels

R. James Rollbuhler
National Aeronautics and Space Administration
Lewis Research Center
Cleveland, Ohio 44135

Work performed for
U.S. DEPARTMENT OF ENERGY
Conservation and Renewable Energy
Office of Vehicle and Engine R&D
Washington, D.C. 20545
Under Interagency Agreement DE-AI01-85CE50111

Prepared for
The Twenty-fifth Automotive Technology Development
Contractors' Coordination Meeting
sponsored by the Society of Automotive Engineers
Dearborn, Michigan, October 26-29, 1987

COMBUSTION CHARACTERISTICS OF GAS TURBINE ALTERNATIVE FUELS

R. James Rollbuhler
National Aeronautics and Space Administration
Lewis Research Center
Cleveland, OH 44135

SUMMARY

E-3869-1

An experimental investigation, cosponsored by the Department of Energy and NASA, was conducted to obtain combustion performance values for specific heavy-end, synthetic hydrocarbon fuels. A flame tube combustor modified to duplicate an advanced gas turbine engine combustor was used for the tests. Each fuel was tested at steady-state operating conditions over a range of mass flow rates, fuel-to-air mass ratio, and inlet air temperatures. The combustion pressure, as well as the hardware, were kept nearly constant over the program test phase. Test results were obtained in regards to geometric temperature pattern factors as a function of combustor wall temperatures, the combustion gas temperature, and the combustion emissions, both as affected by the mass flow rate and fuel-to-air ratio. The synthetic fuels were reacted in the combustor such that for most tests their performance was as good, if not better, than the baseline gasoline or diesel fuel tests. The only detrimental effects were that at high inlet air temperature conditions, fuel decomposition occurred in the fuel atomizing nozzle passages resulting in blockage. And the nitrogen oxide emissions were above EPA limits at low flow rate and high operating temperature conditions.

INTRODUCTION

An advantage that gas turbine engines have over internal combustion engines is that they can operate with a larger selection of alternative fuels. This is especially an advantage if it can be done without major modifications in the engine and with fuels that can be derived, at a relatively low cost, from domestic sources.

Both NASA and the Department of Energy are interested in knowing if performance can be maintained in a given advanced gas turbine combustor at a level comparable to baseline performance with gasoline fuel. The fuels most readily available in this country are heavy-ended hydrocarbon types that are low in hydrogen-to-carbon ratio and high in aromatic content. A common source of such fuel is synthesis from coal. This type of fuel was supplied for this program and is synthesized by a process called "Exxon Donor Solvent" or EDS (ref. 1).

The literature (ref. 2) indicates that fuel lean, homogeneous mixtures of such fuels with air have increased combustion tolerance to the disadvantages of low hydrogen and high aromatic content. If such fuels are not completely oxidized, the combustion flame will contain high carbon concentrations causing high wall temperatures as well as producing excessive nitrogen oxides. So this program had the goal of optimizing the fuel combustion. This requires complete atomization of the fuel and total mixing with an ideal amount of combustion air.

A technique used by the gas turbine manufacturers is lean-burn combustion (ref. 3). This technique utilizes an internal flow field in the combustor that maximizes mixing of the fuel with the air. This minimizes the formation of carbon monoxide and also results in smaller quantities of unburnt hydrocarbons. The combustion gas residence time is minimized and local recirculation regions are avoided to keep the nitrogen oxide formation low. Problems exist in that the combustor must operate over a wide turn down ratio and much of the time this is at idle or low power conditions which negate the lean-burn concept that is used at full power conditions.

The program goal was to determine how efficiently the selected alternative gas turbine fuels would react in an advanced gas turbine combustor operating over a range of conditions. Whereas the combustor operates at maximum efficiency with gasoline at full power conditions, how efficiently will it operate at the same conditions using the various alternative fuels? What will the effect on performance be when operating the combustor over a range of power settings (i.e., different input mass flow rates)?

ALTERNATIVE FUELS TESTED

Eight alternative fuels were tested in this program. All were supplied by South West Research, Inc. under a contract from the Department of Energy. The fuels are listed in table I. The gasoline and diesel fuel served as a baseline performance source. Both have a positive hydrocarbon to aromatic content ratio and the highest hydrogen concentration. The methanol does not quite fit in the same category with the other fuels because of a low heat content value, but it was tested to see how its performance compared. Each of the fuels was tested in sequence in the test rig so as to minimize system contamination from one fuel to another. The fuels were initially at ambient temperatures prior to flowing into the combustor spray nozzle.

TEST FACILITY AND OPERATIONS

The testing was conducted at the Lewis Research Center Fundamental Combustion Research Laboratory. This facility was chosen because it can duplicate the heated combustion air coming out of a regenerative equipped gas turbine engine. This is shown in a schematic diagram (fig. 1). Up to 2 lb of combustion air-per-second can be heated to approximately 1800 °F at 10 atm pressure. This is done by flowing the air through a heated, porous, ceramic heat exchanger. The heat exchanger wheel is heated at variable rates by a gas turbine exhaust on one side and as the ceramic wheel revolves past flexure seals (that keep the exhaust gases separate from the combustion air), it gives up this input heat to the combustion air flowing through it. After the combustion air has flowed through the test section, it is cooled and then released to the atmosphere. The gas pressure in the test section was maintained relatively constant (about 2 atm) by means of a back pressure control valve downstream of the test section. It sensed mass flow rate and adjusted its opening to give the desired pressure.

Operations were such that a desired air mass flow rate and air temperature were programmed into the controls and once the steady-state conditions were attained, the fuel was introduced. The fuel flow rate was adjusted to obtain

the test fuel-to-air ratio and when steady state test data was realized, the test point data were recorded. This usually required 4 to 6 min of operation at any given test condition.

TEST COMBUSTOR

The testing done in this program made use of one combustor. It was basically a flame tube type that was modified to simulate a lean burn, advanced gas turbine combustor. A schematic drawing of the combustor is shown in figure 2.

All the test fuel and 1 to 2 percent of the combustion air were injected into the combustor through an air blast fuel atomizing nozzle. The nozzle was in the head end of the combustor and it was physically isolated from the hot combustion air flowing into the combustor, also at the head end. Being a lean burn concept combustor, none of the air was introduced as diluent downstream. To promote ignition, a combustion cup surrounded the nozzle spray and only enough combustion air was introduced into the cup so as to attain stoichiometric ignition conditions (using a high energy sparking source). The ignited fuel-air mixture was then mixed with the rest of the incoming swirling air and combustion continued down the combustor. The duration of internal combustor reaction, the residence time, was a function of the combustor volume, the mass flow rate, and the gas temperature and pressure. This time was generally 4 to 8 msec, duplicating that of a typical gas turbine combustor.

It was the intent of the program to use one air blast fuel spray nozzle for the entire program, but we had to use two different air blast nozzles. These nozzles are shown in a schematic cross-sectional drawing in figure 3. The initial nozzle is labeled "P-A" and the final one is labeled "C-A". The P-A nozzle worked fine at a low temperature (i.e., up to 1200 °F input air) conditions but at higher temperatures, and especially at low fuel flow rates, blockage and plugging occurred in the small fuel passages. It was very difficult to clean these passages effectively, so we switched to the C-A nozzle. It gave performance similar to the P-A nozzle, including fuel decomposition at high temperature conditions, but it had the advantage that it could be taken apart to be cleaned.

INSTRUMENTATION

The steady-state operation data acquisition consisted of: the fuel input temperature, pressure, and flow rate; the input combustion air (including the nozzle air) temperature, pressure, and flow rate; and the combustion gas pressure and temperature, as well as the gas composition. Fuel flow rates were measured with Flowtron mass flowmeters. The air flow rates were measured with orifice flowmeters and pitot tube flowmeters. Air, fuel, and gas temperatures and pressures were measured with thermocouple probes and strain gage transducers.

The combustion gas composition was determined using a continuous gas sampling probe located at the exit end of the combustor. The probe line was heated to prevent condensation and the sample was analyzed for oxygen, particulates, sulfur oxides, nitrogen oxides, carbon dioxide, carbon monoxide, and unburnt hydrocarbons.

The combustor wall temperatures were measured using individual platinum type R thermocouples brazed into tungsten slugs that were mechanically fastened into the stainless steel combustor wall. The slugs had their inner surface exposed to the combustion gases and they were arranged on three circumferential planes: 5, 8, and 11 in. downstream of the fuel spray nozzle. Each plane had eight equally spaced thermocouples.

The combustion gas temperature was an average from a rake containing 12 thermocouples at the combustor exit. Another thermocouple rake was located in the gas stream, twice the distance downstream from the fuel spray nozzle as the combustion gas thermocouple rake.

TEST PROCEDURE

Each fuel was tested in sequence using a matrix test pattern. That is, a given input air temperature was selected and then a range of different air mass flow rates were run. In any air mass flow rate run sequence, the fuel-to-air ratio was varied. Because of the blockage problems with the P-A fuel nozzle, some of the fuels were re-run using the C-A fuel nozzle.

The input temperature of the air was about 1000, 1250, and 1500 °F. At the higher temperatures we had problems in thermal feedback through the fuel injector face decomposing the fuel. The input air mass flow were about 0.25 to 1 lb/sec. The fuel-to-air ratio range was 0.008 to 0.022, except for the alcohol where the range was 0.015 to 0.040. The lower limit was where flame-out generally occurred and the upper value was set by the thermal load on the combustor walls.

TEST RESULTS

Pattern Factor

A consideration in testing the different fuels is how effectively are they atomized and vaporized using a single fuel nozzle for all the tests. Also do the various fuels react evenly as they proceed through the combustor?

Before each test, the heated air flowed by itself through the combustor. This established a baseline thermal condition to compare to the data obtained when the various fuels were burnt in the combustor. A typical temperature pattern as a function of mass flow at 1400 °F input conditions is shown in figure 4. As the input air mass flow rate increased, above 0.5 lb/sec, the combustion gas average temperature steadied out at about 1380 °F; some of the input heat was being conducted away through the combustor wall. At the same time the combustor wall average circumferential temperatures were increasing at a steady linear rate.

In figure 5 we present the same thermocouple data at a fixed input air temperature and flow rate as a function of the gasoline fuel-to-air input ratio. The wall temperatures increased approximately 200 °F at the 5 in. downstream circumference, 300 °F at the 8 in. downstream circumference, and 350 °F at the 11 in. circumference. The average gas temperatures increased 300 to 500 °F over the baseline air temperature as a function of the fuel-to-air ratio.

Figure 6 is a presentation of the average wall temperature increase for all the fuels tested at a given set of conditions: approximately 2600 lb/hour flow rate, 1450 °F input air temperature and 8 in. downstream of the fuel nozzle. The Canadian tar sand and the EDS blends result in higher wall temperatures than the base fuels over the fuel-to-air ratio range tested. This higher wall temperature might be due in part to high thermal radiation from the aromatics in these fuels, but the main point is that this same pattern is occurring further upstream as well as at this location. There was no problem in bringing about ignition and burning of these heavy-end hydrocarbon fuels at these test conditions.

The tendency for even cross-sectional burning as the reactants proceed through the combustor is revealed in a pattern factor. Whereas, most pattern factors are based on combustion gas temperatures, in this program we used wall temperatures. The selected pattern factor is a function of the maximum wall temperature and the average wall temperatures in a given combustor cross-section plane. One such example is plotted in figure 7 as a function of the tested fuel-to-air ratio for a given cross-sectional plane 11 in. downstream of the fuel nozzle. This plot is also interesting in that it shows how the fuel nozzle blockage problems affect the pattern factors.

The P-A nozzle performance initially resulted in a pattern factor of about 0.2, the value getting lower at higher fuel flow rates and injector pressure drops. As the fuels were tested in sequence with this nozzle, the pattern factor got progressively larger, until with gasoline and alcohol the value was 0.5 or more. This was noticeable also from the fuel injection temperature and pressure. For the 1000 °F input air test the fuel nozzle wall temperature was 200 to 400 °F and the fuel temperature in the nozzle was about 200 °F. When using 1500 °F input air the nozzle wall got to 400 to 600 °F and the fuel temperature got to 400 to 800 °F with the gasoline and alcohol being the highest. The gasoline injection pressure drop essentially doubled. We had vaporization and/or decomposition two phase flow conditions in the nozzle. Decomposition did not occur evenly in each fuel passage so the fuel flow rate became uneven around the nozzle exit circumference.

After trying to clean the P-A nozzle fuel passages without noticeable success, we switched to the C-A fuel nozzle and we were able to obtain test data at a low pattern factor value. We still had high nozzle temperatures and fuel decomposition, but when the pattern factor started increasing, the fuel nozzle was disassembled and the parts were mechanically and ultrasonically cleaned. The C-A nozzle test data for the fuels used was consistently taken at a pattern factor close to 0.2 (fig. 7).

Combustion Gas Temperature Performance

The general performance of the different fuels tested was based on the average combustion gas temperature as measured from a high temperature thermocouple rake at the combustor exit, 18 in. downstream of the fuel nozzle.

The temperatures of the combustion gas from the fuels tested for a given set of operating conditions is shown in figure 8. The average temperatures are plotted as a function of the fuel-to-air ratio. The trends are the same for other mass flows and input air temperatures. Also shown in the figure is the

theoretical gas temperature for the reaction of Jet-A fuel and 1500 °F air (ref. 4). As would be expected, the combustion gas temperature increases as more fuel is mixed with a given quantity of air.

The EDS blends, Canadian tar sand fuel, and hydrogenated EDS all had combustion gas temperatures consistently higher than the baseline gasoline. The alcohol fuel, at the fuel-to-air ratio shown, had the lowest gas temperature.

Although the average combustion gas temperature was increasing with increasing fuel-to-air ratio, it was not doing so at as fast a rate as theoretically possible. This is shown in figure 9 when the percent of theoretical combustion temperature, using the same data as appears on figure 8, is plotted against the fuel-to-air ratio. All the fuels decreased in percent of theoretical temperature with increasing fuel-to-air ratio, some at faster rates than others. The highest efficiency fuel, a blended EDS, decreased from about 95 percent at 0.008 fuel-to-air ratio to about 92 percent at 0.020 fuel-to-air ratio. It may be that with increased gas temperature more of the heat is being radiated away through the combustor and rig walls.

Another explanation for decreasing efficiency with higher fuel-to-air ratios, especially with the lower efficiency fuels, is that the combustor residence time is not long enough. This is shown indirectly in figure 10. The combustion gas minus the exhaust gas temperature is plotted against the fuel-to-air ratio being tested. The combustion gas temperature was measured at the exit of the combustor and the exhaust temperature was measured outside the combustor, twice as far downstream of the fuel nozzle as the combustion temperature.

For those fuels with a high efficiency, e.g., the blended EDS and hydrogenated EDS, the differences between the combustion and exhaust gas temperature is negligible over the tested fuel-to-air ratio. However, for the lower efficiency fuels, such as the gasoline and alcohol, the exhaust gas becomes much hotter than the combustion gas with increased fuel-to-air ratio. This would indicate that at higher fuel flows, these poor fuels require a greater residence time to realize their potential. Along with increased burning time, these fuels may be mixing with additional air outside the combustor which improves their burning characteristics.

Combustion Gas Emissions

The combustion gases at the combustor exit were continuously sampled and checked for emissions of oxygen, carbon dioxide, carbon monoxide, nitrogen oxides, sulfur oxides, unburnt hydrocarbons, and particulate matter.

The gas detection equipment never did measure any meaningful quantities of sulfur oxides or particulate matter. Unburnt hydrocarbons were detected during startup conditions or at low air temperatures or high fuel flow rates which amounted to a small percentage of operating time.

The quantity of oxygen in the combustion gas is a function of the operating fuel-to-air ratio and the combustion efficiency. This is plotted for a given set of operating conditions in figure 11. Also plotted in the figure is the theoretical oxygen concentration burning Jet-A fuel at the same conditions

(ref. 4). The gasoline and alcohol had the highest concentrations at any fuel-to-air ratio compared to the blended EDS and Canadian tar sand fuels.

The quantity of carbon dioxide in the combustion gas behave just the opposite of the oxygen, with increased fuel-to-air ratio. Again, the theoretical carbon dioxide concentration is plotted along with other selected data in figure 12. The carbon dioxide concentration drastically increase with increased fuel burning. The hydrogenated EDS having higher average values than the diesel and gasoline baseline fuels.

The changing concentration of carbon monoxide in the combustion gases was less an effect of the operating fuel-to-air ratio as it was an effect of the combustion air temperature and mass flow rate. This is presented in figure 13 for the baseline fuel gasoline. Here the grams of carbon monoxide produced per 1000 g of gasoline burned is plotted against the fuel-to-air ratio for various operating conditions. Two mass flow rates are shown, approximately 0.50 and 1 lb/sec of air, and three air temperatures, 1000 °F, 1250 °F, and 1500 °F range, for each mass flow rate. The greatest quantity of carbon monoxide was produced at the high mass flow rates and low input air temperatures. As these conditions changed, the carbon monoxide decreased until it was less than the required EPA limit of 38 at the lower mass flow and/or higher input air temperature.

In figure 14, the carbon monoxide concentration value for other fuels is plotted at specific conditions. When the input air temperature was approximately 1500 °F, all the fuels had carbon monoxide concentrations whose index value was less than 20.

The nitrogen oxide emissions value is also a function of the temperature, but opposite to that occurring for the carbon monoxide. As the input air temperature (and the combustion gas temperature) increased, the oxidation of the nitrogen in the combustion air also increased. For this program test, the fuel-to-air ratio appears to have a minor affect compared to the mass flow rate and input temperature. This is shown in figure 15 for the burning of gasoline at specific conditions. As the mass flow rate was decreased from 1 to 0.5 lb/sec, and the input temperature was increased, the emission value of the nitrogen oxide increased; the change in temperature having the most effect. The larger mass flow is indicative of lower residence time giving the gases less time at high temperatures to react and form the nitrogen oxides.

The nitrogen oxide emissions values for the other fuels tested using the C-A nozzle hardware are shown in figure 16. At a given mass flow rate, the hydrogenated EDS had the lowest emission value at any input temperature. Unfortunately, it was still above the EPA limitations of 4.6 at the higher input temperatures.

CONCLUSION

The alternative fuels tested in this program gave very good performance results in comparison with the baseline gasoline results. This may have been because of a lean burn combustor and an air blast fuel nozzle being used. The hydrogenated EDS and the blended EDS fuels had a uniform combustion pattern, a high combustion gas temperature, and low emission concentrations in respect to the results obtained with the other fuels.

Problem areas associated with operations at high inlet combustion air temperatures and low power or idle fuel flow rates is fuel vaporization and/or decomposition within the fuel nozzle. This can lead to nonuniform fuel passage fouling. This is more of a problem with low boiling range fuels like gasoline and alcohol rather than the higher boiling range synthetic fuels.

Ignition was no problem with any of the fuels in the fuel-to-air range being tested. Of course, the minimum air temperature was 800 °F at which ignition was occurring and it is still a question as to what the ignition characteristics would be with these synthetic base fuels using ambient temperature air for starting.

REFERENCES

1. Schultz, D.F.: Summary of Synfuel Characterization and Combustion Studies. NASA TM 83066, DOE/NASA/13111-15, 1983.
2. Sutton, R.D.; Troth, D.L.; and Miles, G.A.: Analytical Fuel Property Effects on Small Combustors. (EDR-11683, Detroit Diesel Allison; NASA contract NAS3-23165) NASA CR-174738, 1984.
3. Sanborn, J.W.; Mongia, H.C.; and Kidwell, J.R.: Design of a Low-Emission Combustor for the Automotive Gas Turbine. AIAA Paper 83-0338, Jan. 1983.
4. Jones, R.E., et al.: Combustion Gas Properties. I-ASTM Jet-A-Fuel and Dry Air. NASA TP-2359, 1984.

NASA LEWIS RESEARCH CENTER AGT ALTERNATIVE FUELS TEST PROGRAM

Fuels	Element analysis, wt %				Saturated hydrocarbons, vol %	Aromatic hydrocarbons, vol %	Net heat value, Btu/lb
	C	H	S	O			
Gasoline	85	13	---	---	60	36	18 249
No. 2 Diesel fuel	86	13	0.4	---	66	32	18 295
Tar sands diesel fuel	87	12	.7	---	33	67	17 934
Methanol	37	13	---	---	--	--	8 570
Exxon donor solvent (EDS)	89	10	---	0.3	18	75	17 794
Hydrogenated EDS	88	11	---	.1	37	63	17 990
Blend of 50 percent EDS and 50 percent diesel fuel	87	12	.2	.2	37	63	18 008
Blend of 77 percent EDS and 23 percent diesel fuel	88	11	.1	.4	--	--	17 881

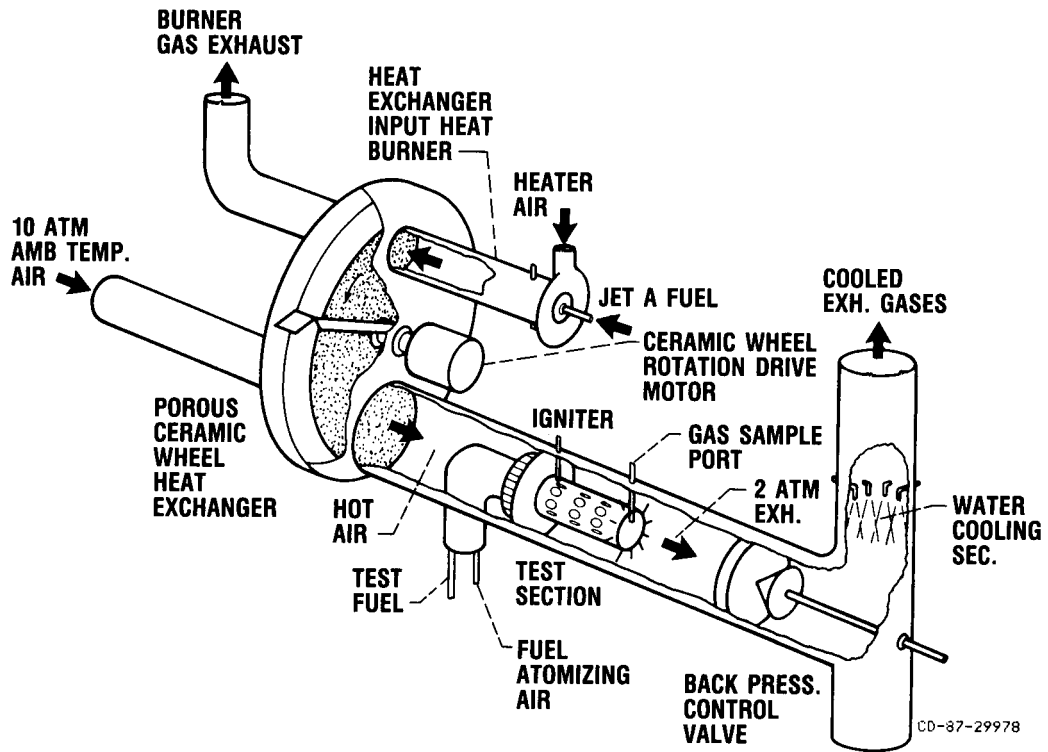

FIGURE 1. - TEST FACILITY SCHEMATIC.

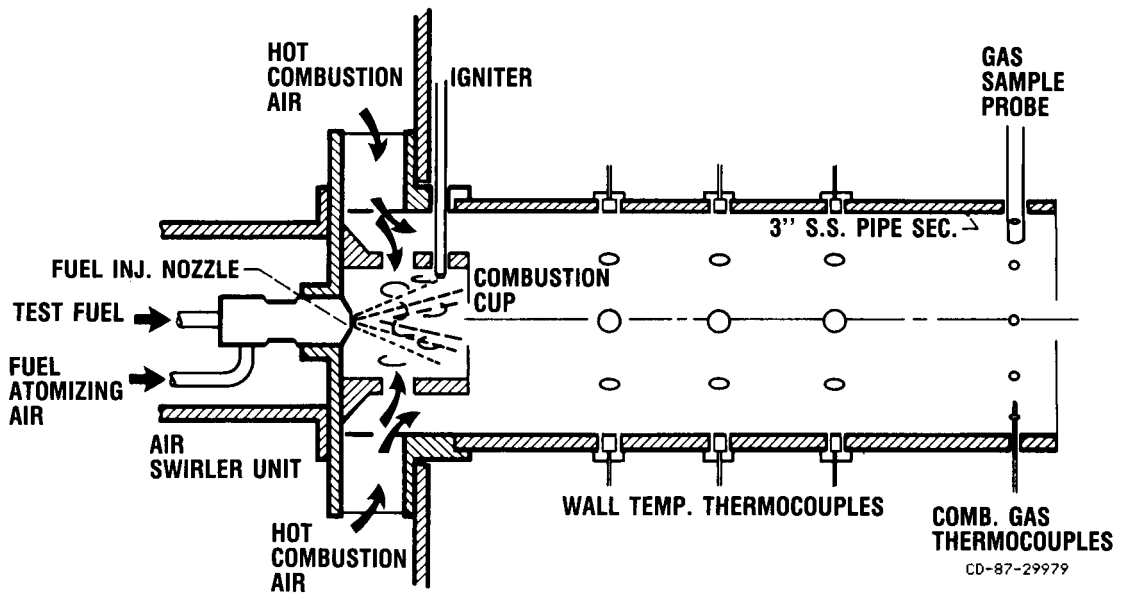

FIGURE 2. - TEST COMBUSTOR CROSS-SECTION.

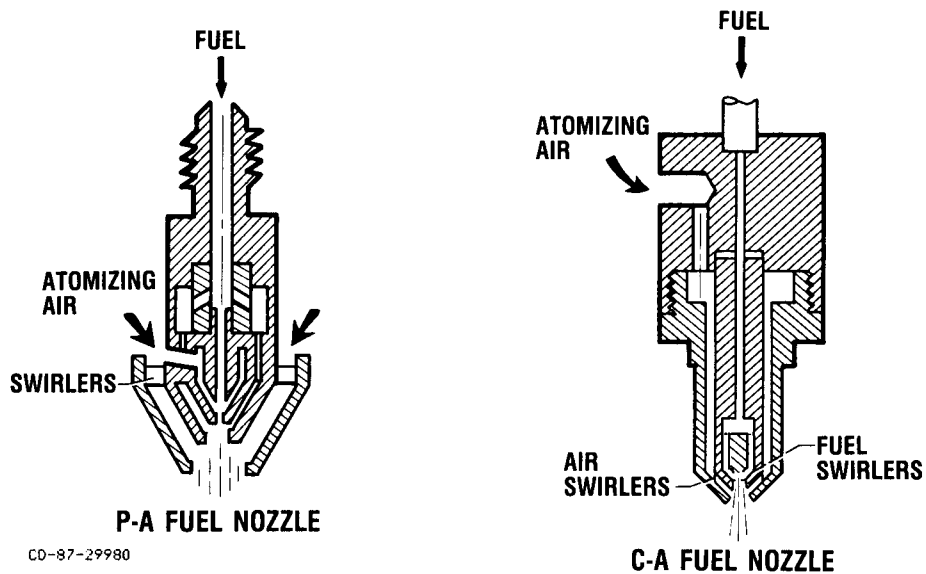

FIGURE 3. - TEST COMBUSTOR FUEL ATOMIZING NOZZLES.

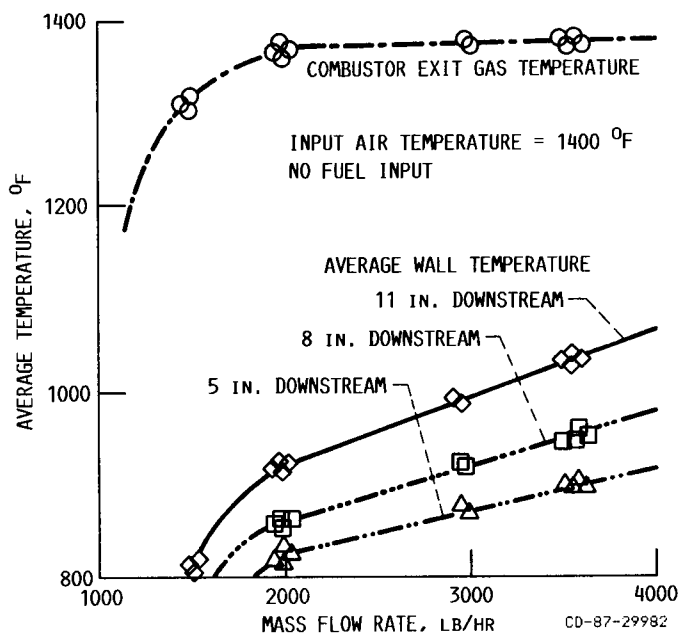

FIGURE 4. - COMBUSTOR TEMPERATURES, AIR FLOW ONLY.

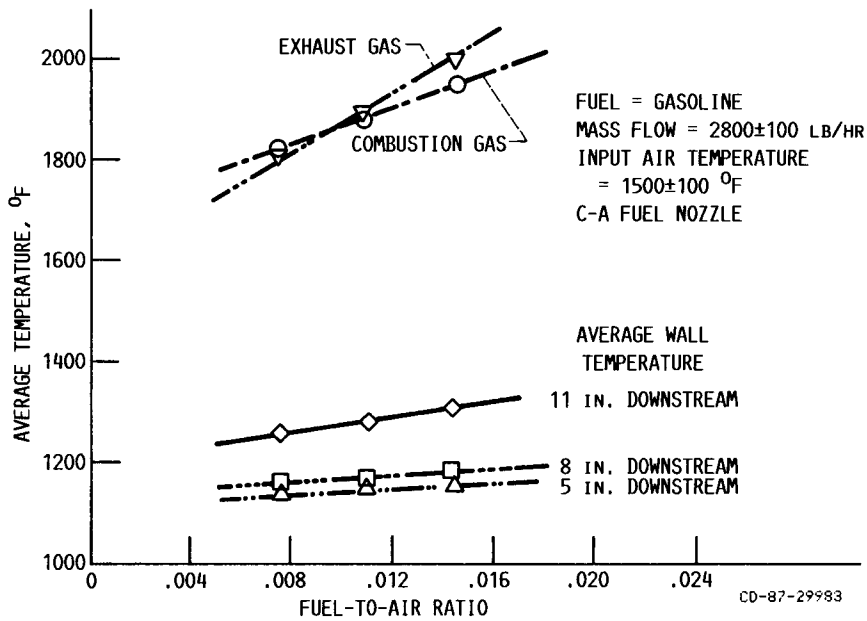

FIGURE 5. - COMBUSTOR TEMPERATURES DURING THE BURNING OF GASOLINE.

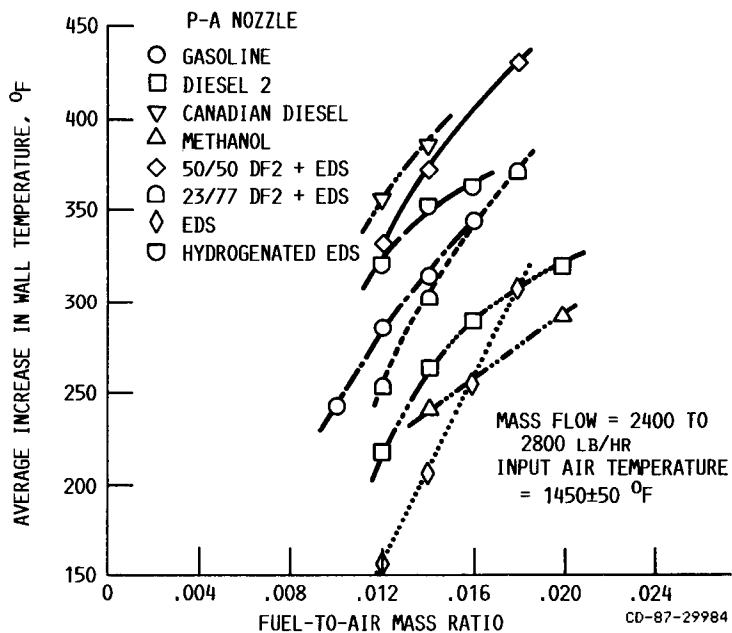

FIGURE 6. - COMBUSTOR WALL TEMPERATURE INCREASE (8 IN. DOWNSTREAM) BURNING DIFFERENT FUELS.

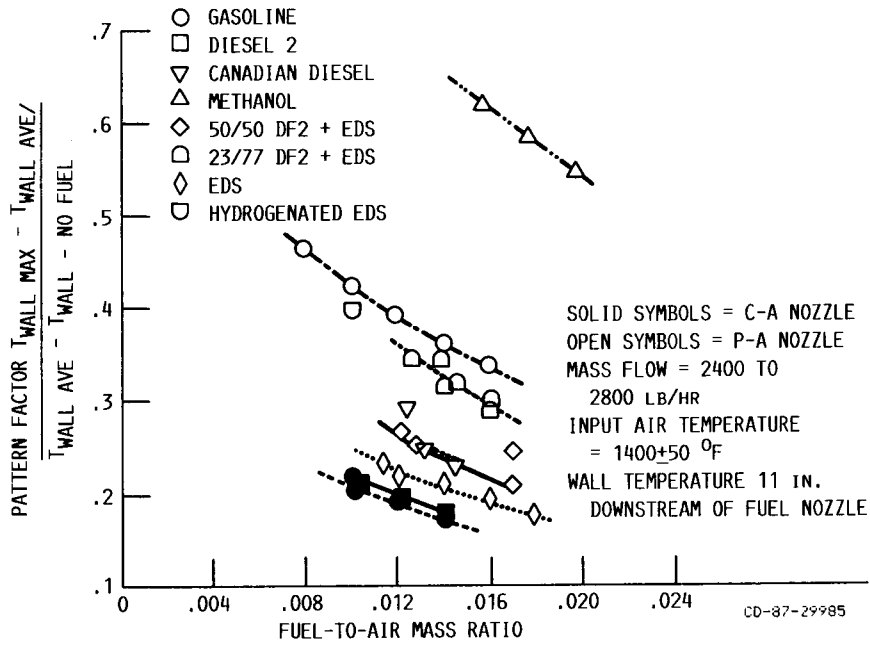

FIGURE 7. - COMBUSTOR WALL TEMPERATURE PATTERN FACTOR FOR THE BURNING OF DIFFERENT FUELS.

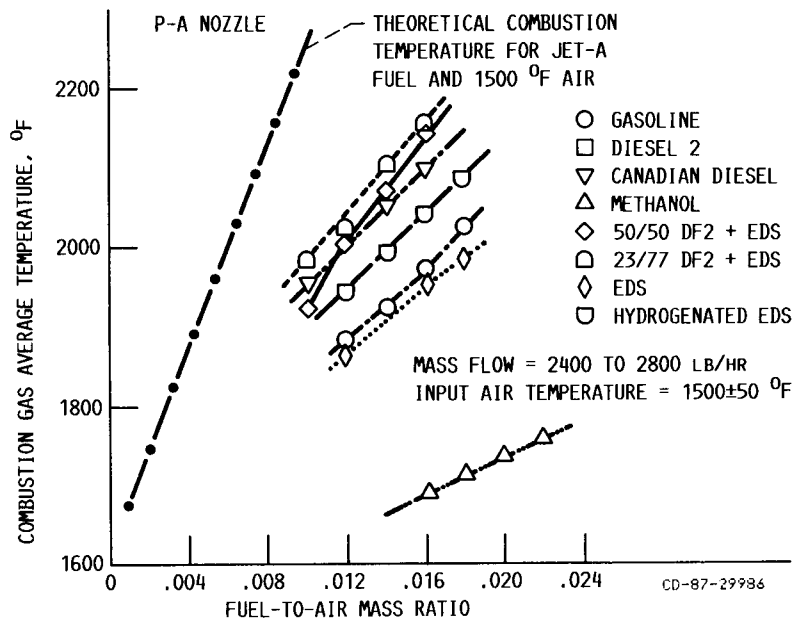

FIGURE 8. - COMBUSTOR GAS TEMPERATURE WHEN BURNING DIFFERENT FUELS.

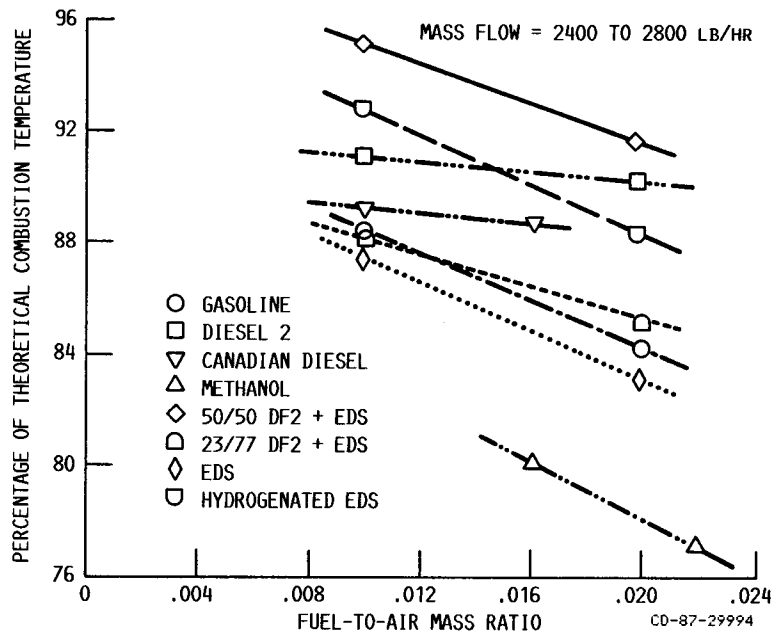

FIGURE 9. - THEORETICAL COMBUSTION EFFICIENCY WHEN BURNING DIFFERENT FUELS.

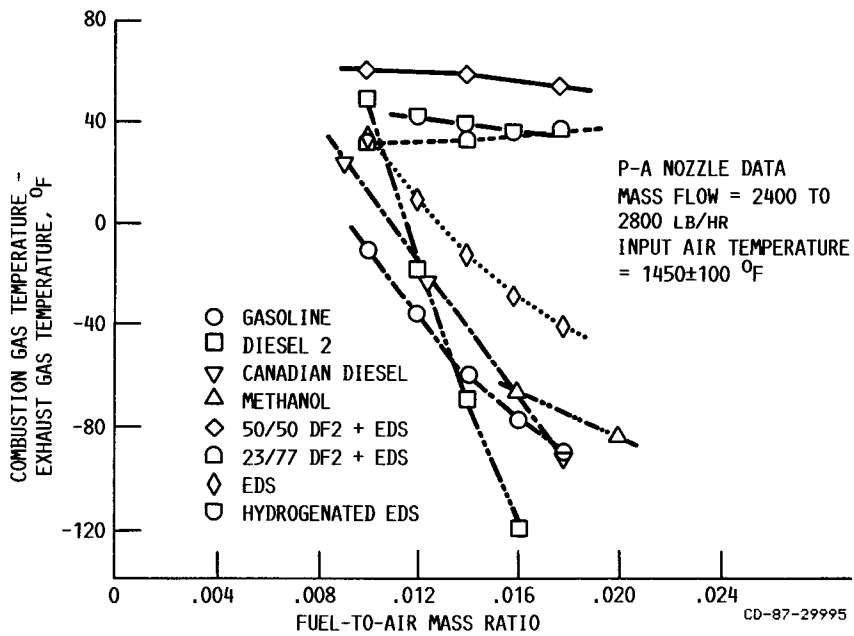

FIGURE 10. - TEMPERATURE DIFFERENCE BETWEEN COMBUSTION AND EXHAUST GASES WHEN BURNING DIFFERENT FUELS.

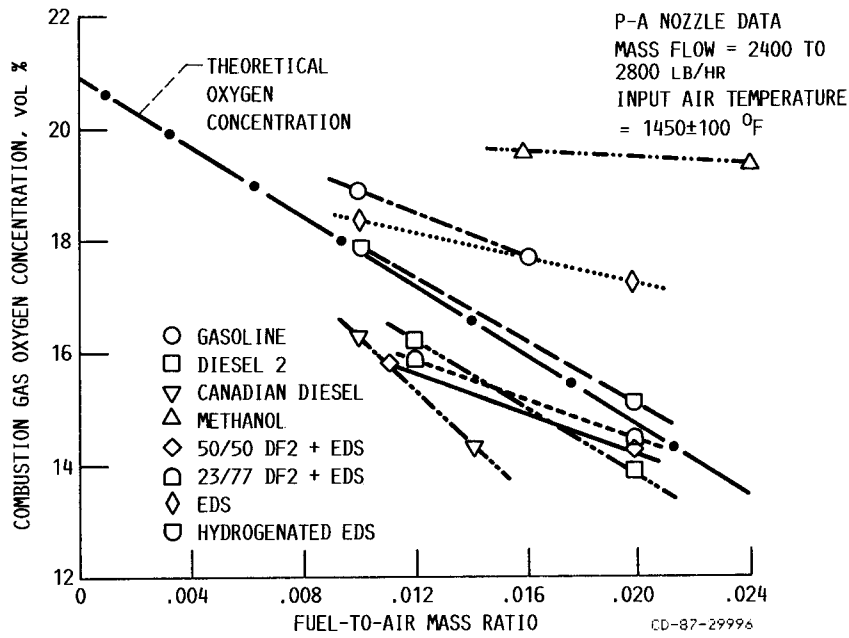

FIGURE 11. - COMBUSTION GAS OXYGEN CONCENTRATIONS.

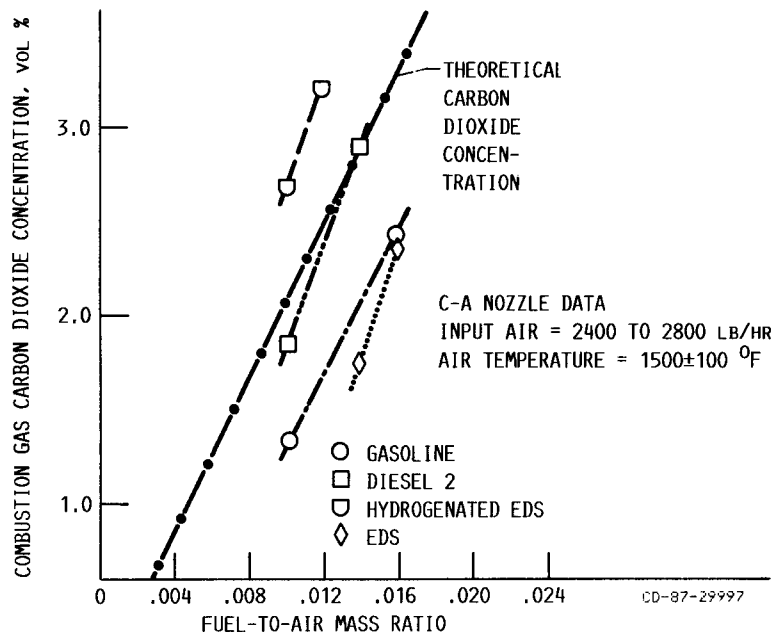

FIGURE 12. - COMBUSTION GAS CARBON DIOXIDE CONCENTRATIONS.

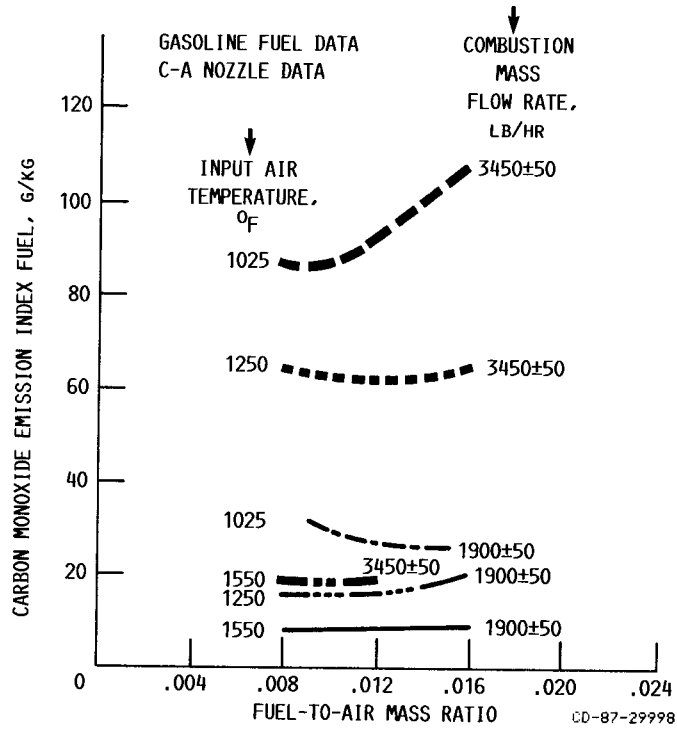

FIGURE 13. - COMBUSTION GAS CARBON MONOXIDE EMISSION VALUES WHEN BURNING GASOLINE.

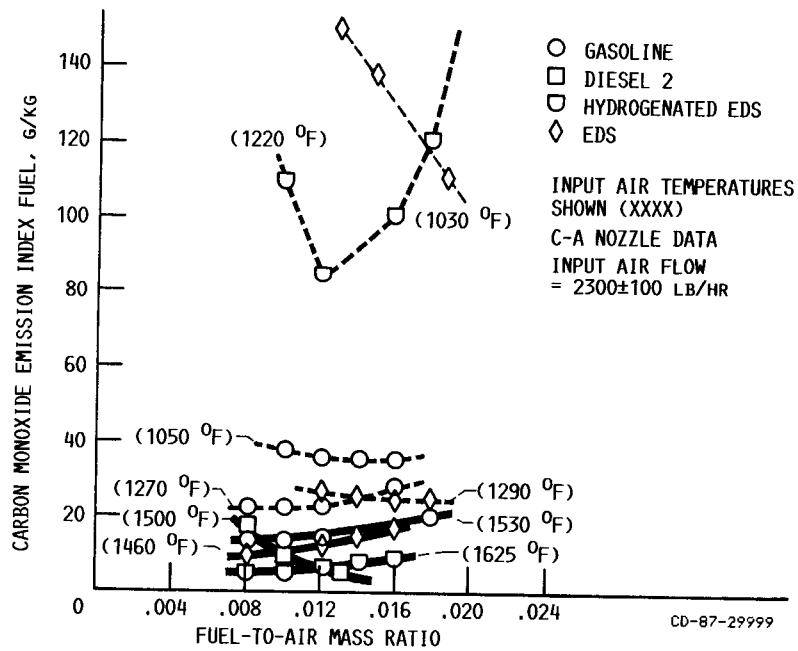

FIGURE 14. - COMBUSTION GAS CARBON MONOXIDE EMISSION VALUES WHEN BURNING DIFFERENT FUELS.

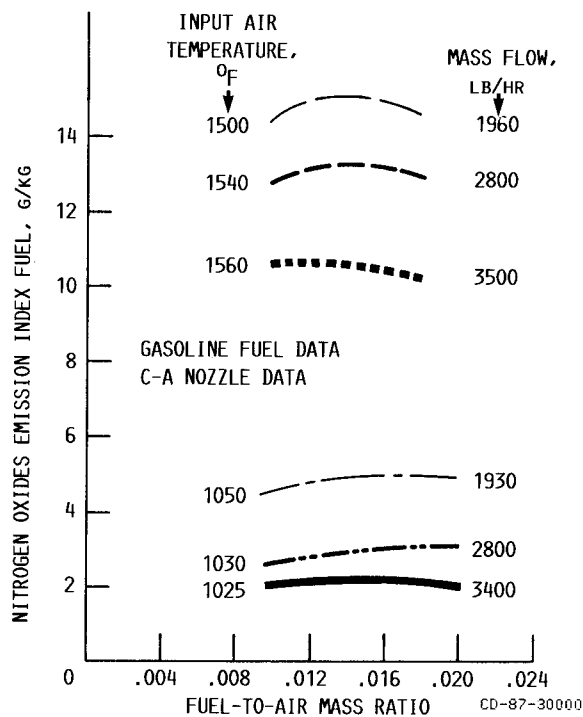

FIGURE 15. - COMBUSTION GAS NITROGEN OXIDES EMISSION VALUES WHEN BURNING GASOLINE.

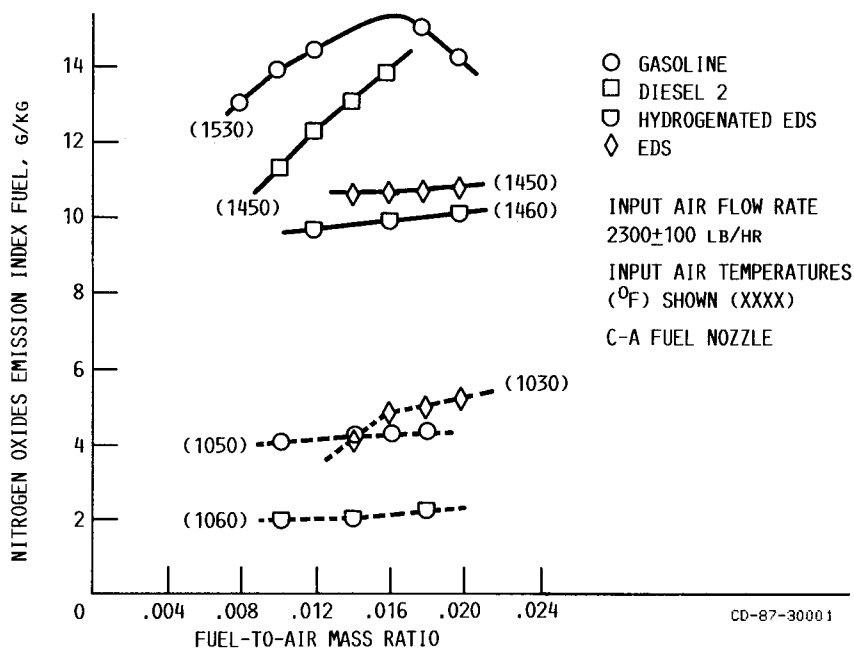

FIGURE 16. - COMBUSTION GAS NITROGEN OXIDES EMISSION VALUES WHEN BURNING DIFFERENT FUELS.



Report Documentation Page

1. Report No. NASA TM-100247		2. Government Accession No.		3. Recipient's Catalog No.	
4. Title and Subtitle Combustion Characteristics of Gas Turbine Alternative Fuels			5. Report Date December 1987		
			6. Performing Organization Code 778-32-11		
7. Author(s) R. James Rollbuhler			8. Performing Organization Report No. E-3869		
			10. Work Unit No.		
9. Performing Organization Name and Address National Aeronautics and Space Administration Lewis Research Center Cleveland, Ohio 44135-3191			11. Contract or Grant No.		
			13. Type of Report and Period Covered Technical Memorandum		
12. Sponsoring Agency Name and Address U.S. Department of Energy Office of Vehicle and Engine R&D Washington, D.C. 20545			14. Sponsoring Agency Code Report No. DOE/NASA/50111-1		
			15. Supplementary Notes Final Report. Prepared under Interagency Agreement DE-AI01-85CE50111. Prepared for the Twenty-fifth Automotive Technology Development Contractors' Coordination Meeting (ATD/CCM), sponsored by the Society of Automotive Engineers, Dearborn, Michigan, October 26-29, 1987.		
16. Abstract An experimental investigation, cosponsored by the Department of Energy and NASA, was conducted to obtain combustion performance values for specific heavy-end, synthetic hydrocarbon fuels. A flame tube combustor modified to duplicate an advanced gas turbine engine combustor was used for the tests. Each fuel was tested at steady-state operating conditions over a range of mass flow rates, fuel-to-air mass ratio, and inlet air temperatures. The combustion pressure, as well as the hardware, were kept nearly constant over the program test phase. Test results were obtained in regards to geometric temperature pattern factors as a function of combustor wall temperatures, the combustion gas temperature, and the combustion emissions, both as affected by the mass flow rate and fuel-to-air ratio. The synthetic fuels were reacted in the combustor such that for most tests their performance was as good, if not better, than the baseline gasoline or diesel fuel tests. The only detrimental effects were that at high inlet air temperature conditions, fuel decomposition occurred in the fuel atomizing nozzle passages resulting in blockage. And the nitrogen oxide emissions were above EPA limits at low flow rate and high operating temperature conditions.					
17. Key Words (Suggested by Author(s)) Alternative fuels; Gas turbine combustor; Hydrocarbon fuel testing			18. Distribution Statement Unclassified - Unlimited Subject Category 07 DOE Category UC-96		
19. Security Classif. (of this report) Unclassified		20. Security Classif. (of this page) Unclassified		21. No of pages 17	22. Price* A02