

# Kent Academic Repository

## Full text document (pdf)

### Citation for published version

Cai, Yuan-Ming and Gao, Steven and Yin, Yingzeng and Li, Wenting and Luo, Qi (2016) Compact-Size Low-Profile Wideband Circularly Polarized Omnidirectional Patch Antenna With Reconfigurable Polarizations. IEEE Transactions on Antennas and Propagation, 64 (5). pp. 2016-2021. ISSN 0018-926X.

### DOI

<https://doi.org/10.1109/TAP.2016.2535502>

### Link to record in KAR

<http://kar.kent.ac.uk/55777/>

### Document Version

Author's Accepted Manuscript

#### Copyright & reuse

Content in the Kent Academic Repository is made available for research purposes. Unless otherwise stated all content is protected by copyright and in the absence of an open licence (eg Creative Commons), permissions for further reuse of content should be sought from the publisher, author or other copyright holder.

#### Versions of research

The version in the Kent Academic Repository may differ from the final published version.

Users are advised to check <http://kar.kent.ac.uk> for the status of the paper. **Users should always cite the published version of record.**

#### Enquiries

For any further enquiries regarding the licence status of this document, please contact:

[researchsupport@kent.ac.uk](mailto:researchsupport@kent.ac.uk)

If you believe this document infringes copyright then please contact the KAR admin team with the take-down information provided at <http://kar.kent.ac.uk/contact.html>

# Compact Low-Profile Wideband Omnidirectional Circularly Polarized Patch Antenna with reconfigurable polarization

Yuanming Cai, Steven Gao, Member, IEEE, Yingzeng Yin, Wenting Li

**Abstract**— A compact polarization reconfigurable wideband omnidirectional circularly polarized (CP) antenna is presented in this paper. This design is based on a low profile omnidirectional CP antenna which consists of a microstrip antenna working on  $TM_{01}/TM_{02}$  modes with slots etched on the ground plane. Vias are introduced between the patch and the ground plane, in order to excite the  $TM_{01}$  and  $TM_{02}$  modes which generate vertically polarized electric field within a wide frequency band. Sequential bended slots are introduced on the ground plane to radiate horizontally polarized electric field. As the result of the combined radiations from both the patch antenna and the sequential slots, left hand circularly polarized (LHCP) omnidirectional radiation pattern is obtained. The polarization reconfigurable is realized by introducing PIN diodes on the slots and through controlling the states of the PIN diodes, the effective orientation of the slots on ground plane can be adjusted and the polarization of this antenna can be altered between LHCP and RHCP (right hand circularly polarization). To verify this design concept, one LHCP and one polarization reconfigurable prototypes at 2.4GHz band were designed and fabricated. Experimental results show good agreement with the simulation results. The LHCP antenna exhibits a wide impedance bandwidth of 18.4% from 2.12 to 2.57 GHz and 3dB-axial ratio (AR) bandwidth of 450MHz. For the polarization reconfigurable antenna, 19.8% (2.09 GHz -2.55 GHz) overlapped 3 dB AR and 10 dB impedance bandwidths is obtained. The present design has thickness of only  $0.024\lambda$  and exhibit stable CP omnidirectional conical-beam radiation patterns within the operating frequency band with good circularly polarization.

**Index Terms**—wideband, compact, Circular polarization, sequential bended slots, low profile, polarization reconfigurable, PIN diodes, omnidirectional antenna

## I. INTRODUCTION

Circularly polarized (CP) antennas are widely used in wireless communication system, because of the reduction on multipath fading and robust on the misaligned orientation between transmitters and receivers. On the other hand, omnidirectional antenna is desirable as it can provide wide signal coverage. As a result, omnidirectional CP antennas have been attracted much research interests. Omnidirectional CP antennas realized by radially arranging radiators, including

the use of four monopoles fed by in-phase signals [1], ten slots curved on a radial waveguide [2], eight resonant elements surrounding the fed probe [3] and four CP rectangular loop radiators printed on a flexible substrate cylinder [4], were reported. Dielectric Resonator Antenna (DRA) [5], and monopole with Loop Radiators [6, 7] with omnidirectional radiation pattern and wide bandwidth were also reported. However, these designs exhibit high profile and not suitable for the compact applications.

A microstrip antenna utilizing Zeroth-Order Resonance of Epsilon Negative Transmission Line was presented in [8] and the profile of antenna is only 3.175mm ( $0.016 \lambda_0$  at center frequency). An compact omnidirectional antenna of circular polarization consists of four bended monopoles were studied in [9], and the profile is 9.3mm ( $0.076 \lambda_0$ ). The profile of these antennas are relatively low; however, they suffer from the narrow bandwidth (0.5% and 3.56%). In addition, a hybrid fed high order microstrip antenna with 28.2% bandwidth was presented [10]. The wideband performance was achieved by the use of air layer, which increases the dimensions of the antenna. Although the profile of this antenna is 10mm ( $0.1 \lambda_0$ ), but the size of ground plane is large and with complex feeding structure.

Low-profile wide band omnidirectional antenna can be realized by combine two kinds of low profile wideband radiator to generate omnidirectional vertical and horizontal polarized waves. A broadband low profile vertical polarized omnidirectional monopolar antenna was proposed in [11], achieving 18% impedance bandwidth. Some omnidirectional antenna base on such concept have been proposed recently. Seven extended curved branches [12] and eight parasitic loop stubs [13] can be used to obtain low-profile omnidirectional CP radiation. Although the wideband characteristic (19.3% and 14.4%) was obtained, those techniques need to use parasitic radiators which increase the overall size of antenna.

In modern wireless communication systems, polarization reconfigurable antenna are highly desirable to mitigate the multipath problem and increase the system capacity. Single-fed microstrip antenna is attractive among polarization reconfigurable antennas because of the simple structure, compact size and easy DC biasing design. The previous studies of CP polarization reconfigurable antenna are more focused on the broadside radiation antenna [14-16]. A reconfigurable CP microstrip antennas with conical-beam radiation was reported in [17]. However, the operational band of two CP polarization are different (LHCP operating band at the center frequency 2.475 GHz and RHCP operating band at

Yuanming Cai and Yingzeng Yin are with the Science and Technology on Antennas and Microwave Lab., Xidian University, Xi'an, Shaanxi, 710071, China (e-mail: [yycymcym@gmail.com](mailto:yycymcym@gmail.com); [zyyin@mail.xidian.edu.cn](mailto:zyyin@mail.xidian.edu.cn)).

Steven Gao and Wenting Li are with the School of Engineering and Digital Arts, University of Kent, Canterbury CT2 7NT, U.K. (e-mail: [s.gao@kent.ac.uk](mailto:s.gao@kent.ac.uk); [w183@kent.ac.uk](mailto:w183@kent.ac.uk)).

the center frequency 2.895 GHz). Moreover, both bandwidths are very narrow (1.6% for LHCP band 2% for RHCP band).

In this paper, we propose a novel design method for compact omnidirectional CP antenna. The antenna is based on the microstrip monopolar patch antenna. Sequential bended slots are etched on the ground plane of the microstrip monopolar patch antenna without increasing the size of the antenna. Each of the slots consists of a tangential directional part and a radial directional part. The tangential part under the patch provides electromagnetic coupling to excite the radial part to radiate horizontal electric field. Combined with the vertical polarized field generated by the monopolar patch antenna, the antenna exhibits omnidirectional CP radiation within wide frequency band. Based on the proposed omnidirectional CP antenna, a polarization reconfigurable antenna was designed. By changing the effective orientation of the slot on ground plane of proposed omnidirectional CP antenna by controlling the states of the PIN diodes, the polarization can be alternated between LHCP and RHCP. Due to the low cost, low insertion loss and high isolation, PIN diodes (SKYWORKS SMP1345-079LF)[18] are chosen in this study. Six inductors are mounted across the slots which significantly simplifies the DC control circuit. Single voltage is used to control all the diodes. When positive voltage is applied, LHCP radiation can be obtained whilst RHCP can be realized when negative voltage is applied.

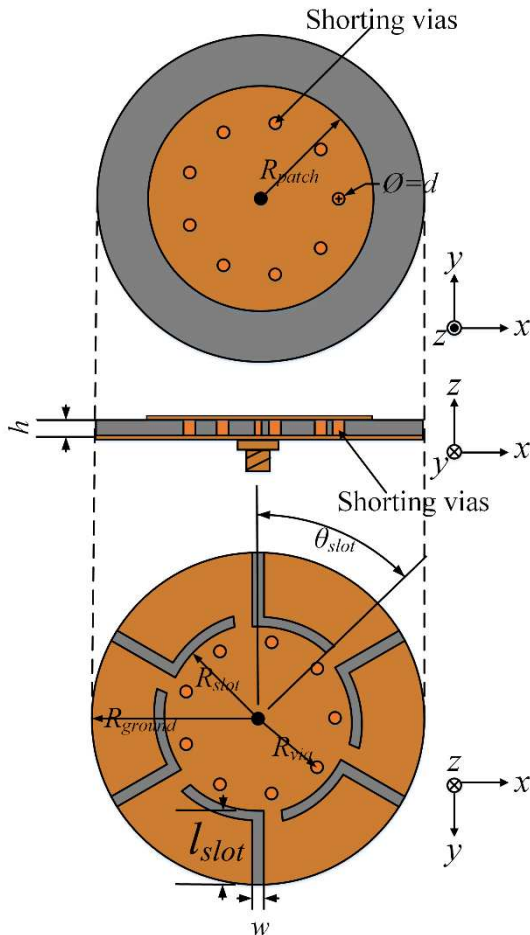

Fig.1. Geometry of omnidirectional LHCP antenna

To verify the design concept, both the omnidirectional LHCP antenna and polarization reconfigurable antenna are designed and fabricated. The proposed antennas have overlapped 10-dB impedance and 3dB-AR bandwidth of 18.4% and 19.8%, respectively. In addition, the profiles of the antennas are only  $0.024\lambda$ . The proposed antennas have the advantages of low profiles, wide CP operational bands and simple structures.

This paper is organized as follows. The detailed design method and measurement of the conical beam omnidirectional LHCP antenna is presented in Section II. The configuration and experimental result of polarization reconfigurable antenna is described in Section III. Section IV concludes this paper.

## II. CONICAL BEAM OMNIDIRECTIONAL CP ANTENNA DESIGN

### A. Antenna configuration

The configuration of proposed LHCP antenna with conical omnidirectional beam is shown in Fig.1. It consists of a circular patch with a radius of  $R_{\text{patch}}$  and six sequential bended slots etched on the ground plane. The radius of ground plane is  $R_{\text{ground}}$  and the distance between the center of ground plane and slot edge is  $R_{\text{slot}}$ . Each slot has a radial length of  $l_{\text{slot}}$  and arc angle of  $\theta_{\text{slot}}$ . Nine shorting pins with diameter of  $d$  are used to short the circular patch and ground plane. The distance between patch center and shorting pin center is  $R_{\text{via}}$ . The circular patch and its ground plane were printed on each side of a substrate with relative permittivity of  $\epsilon_r$  and thickness of  $h$ . The antenna is fed by a coaxial probe of SMA connector with pin located at the center of the circular patch. The detailed values of these parameters are shown in Table I.

Table I  
The parameters of the proposed omnidirectional CP antenna

$R_{\text{Patch}}$	$R_{\text{ground}}$	$R_{\text{slot}}$	$R_{\text{via}}$	$d$
39.5mm	60mm	34mm	29.5mm	1.6mm
$l_{\text{slot}}$	$\theta_{\text{slot}}$	$\epsilon_r$	$h$	
26mm	48°	2.2	3.175mm	

### B. Principle of operation and design method

The design of proposed antenna is based on the concept that low-profile wide band omnidirectional antenna can be realized by combine two types of low profile wideband radiator to generate omnidirectional vertical and horizontal polarized waves. Therefore, a wideband omnidirectional vertical polarized antenna is designed at first. The center-fed microstrip monopolar patch antenna has a wide bandwidth and a monopole like radiation pattern [11]. By adjusting the positions and number of the shorting pins, two frequencies of the fundamental modes  $TM_{01}$  and  $TM_{02}$  can be tuned to form a wideband response. To verify this, two models with and without the shorting pins were simulated and compared. Fig. 2 shows the simulated reflection coefficient of the antennas with and without the shorting pins. The antenna without shorting pins shows only one  $TM_{02}$  mode resonant frequency at 2.5

GHz, while the antenna with shorting pins shows two resonant frequency at both 2.2 GHz and 2.5GHz. It can be seen clearly that by adding shorting pins, another low frequency resonant at 2.2 GHz is obtained and better impedance matching is achieved. The approximate radius of the circular patch can be calculated by using TM<sub>02</sub> mode cylindrical cavity which is given by:

$$k_0\sqrt{\epsilon_r}R_{eff} = 3.83171$$

$$R_{eff} = R_{patch} \sqrt{1 + \frac{2t}{\pi R_{patch}\epsilon_r} \left( \ln \frac{\pi R_{patch}}{2t} + 1.7726 \right)}$$

where  $k_0$  is the wavenumber in free space.  $R_{eff}$  is the effective radius of the circular patch antenna [19].

For good circular polarization, two orthogonal linear polarizations with same magnitude should be excited with 90-degree phase difference. In order to produce horizontal polarized field, bended slots were introduced on the antenna ground plane. Each bended slot has two parts, an arc part for coupling and a radial part for microwave radiation. The arc slot is perpendicular to the radius of the patch, which forces the current flows around the slot. Therefore electromagnetic coupling can be introduced to excite the radial slot radiator to generate horizontal polarized field. Six slots radiator are arranged sequentially along the circumference of the ground plane, with an accordant angular interval of  $360^\circ/6$ , to guarantee the equal magnitude at different azimuth directions.

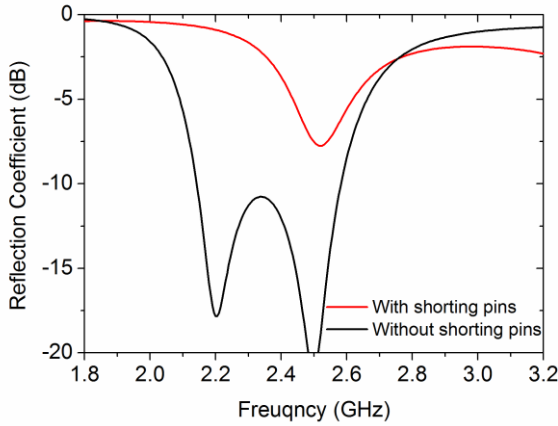

Fig. 2. Simulated reflection coefficient of antennas with and without the shorting pins

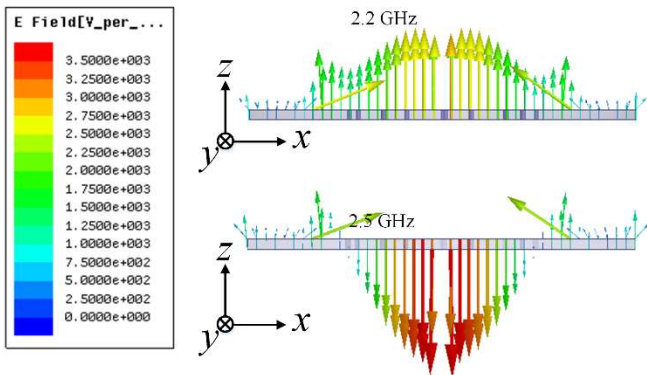

Fig.3 Simulated resonant E-field in elevation plane.

Fig 3 shows the electric field distributions between the patch and ground at TM<sub>01</sub> and TM<sub>02</sub> modes. It can be seen that, the field distribute is different for the TM<sub>01</sub> and TM<sub>02</sub> mode at frequency of 2.2GHz and 2.5GHz. The electric field of TM<sub>02</sub> mode has the opposite direction at both sides of the shorting pins, while the TM<sub>01</sub> mode has the same directions. However, the field distributions between shorting pins and the open edge are similar at both TM<sub>01</sub> mode and TM<sub>02</sub> mode. This means that, the field distribution around the slots are similar at two frequencies. Therefore the energy coupling between monopolar antenna and slot is stable within wide frequency range which leads to the stable antenna performance within wide frequency band.

The 90-degree phase difference between the two orthogonal linear polarizations is realized by adjusting the length of the ace slot. The ace slot can not only work as a coupler but also a section of transmission line to produce phase shift. The simulated phase different between  $E_\theta$  and  $E_\phi$  at  $\theta=40^\circ$ ,  $\phi=0^\circ$  with different value of ace angles are plotted in Fig. 4(a). The length of ace slot is critical to produce wideband AR. As shown in Fig. 4(b) the optimized antenna can achieve 18% AR bandwidth.

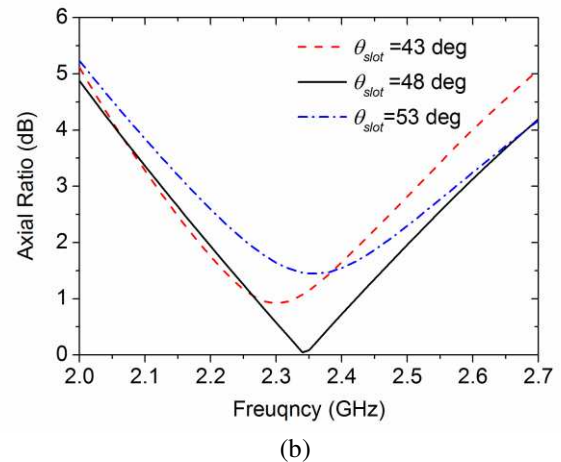
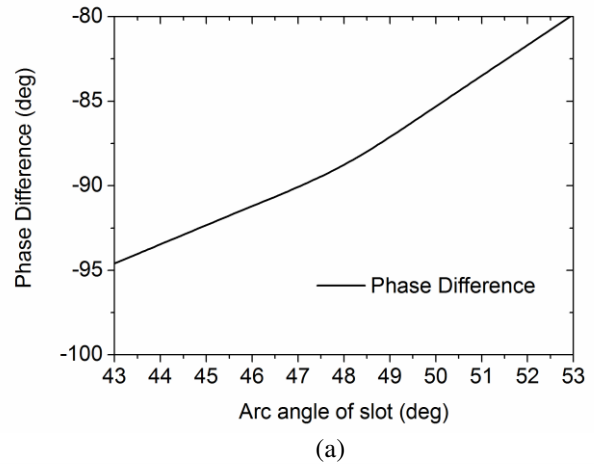

Fig.4. Simulated (a) phase different between  $E_\theta$  and  $E_\phi$  and (b) AR at  $\theta=40^\circ$ ,  $\phi=0^\circ$



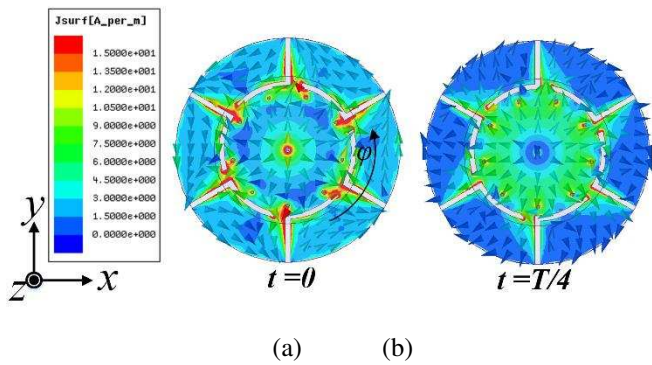

Fig. 5. Current distribution at 2.4GHz at time (a)  $t=0$  and (b)  $t=T/4$

The simulated current distribution at 2.4GHz at time  $t=0$  and  $t=T/4$  are plotted in Fig. 5, where  $T$  is the period of time. The horizontal and vertical polarized electrical field is provided by the surface current in radial direction and  $\varphi$  direction, respectively. At time  $t=0$ , current flows at direction of  $+\varphi$ , which produces horizontal polarized radiation. While at time  $t=T/4$ , strong radial current can be observed which generates vertical polarized radiation. It should be noted that, the slot work as a 1.5 wavelength radiator, which can be seen on Fig. 5.

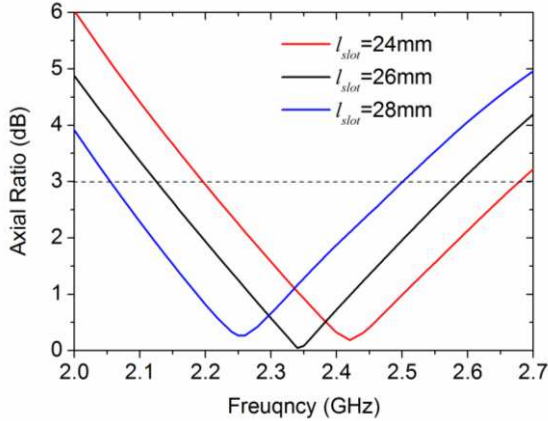

Fig. 6. The simulated AR curve with different value of  $l_{slot}$ .

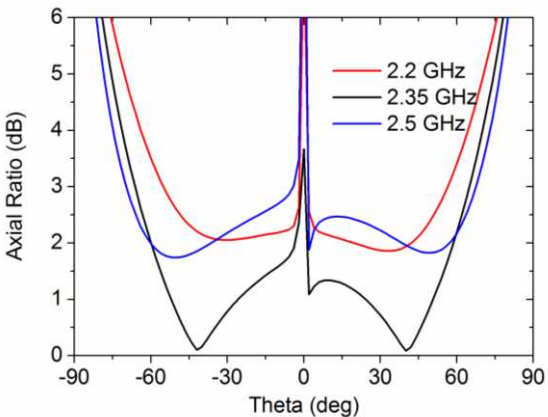

Fig. 7. The simulated AR beamwidth of the proposed LHCP antenna.

Fig. 6 shows the simulated AR with different value of  $l_{slot}$ . The length of slot determines the resonate frequency of the slot

radiator. Therefore, the AR band shifts towards higher frequency with increased length of slot.

Fig. 7 shows the AR beamwidth of the proposed antenna at different frequencies. The AR beamwidth is wide at both higher frequency and lower frequency. The AR beamwidth covers a wide range from  $2^\circ$  to  $55^\circ$ . Good circularly polarized radiation around  $40^\circ$  is obtained within wide frequency band.

The polarization of the proposed antenna can be alternated between LHCP and RHCP by changing the orientation of the sequential bended slots. As will be presented later in section III, the polarization reconfigurable is realized based on this concept.

### C. Simulated and Measured Results

The prototype of proposed conical beam omnidirectional antenna was fabricated and the photos of the prototype are shown in Fig. 8. The reflection coefficient was measured with the Rohde & Schwarz ZVL vector network analyzer. The axial ratios and radiation patterns were evaluated in an anechoic chamber in University of Kent. All the numerical simulations were performed by using the Ansys HFSS V15.

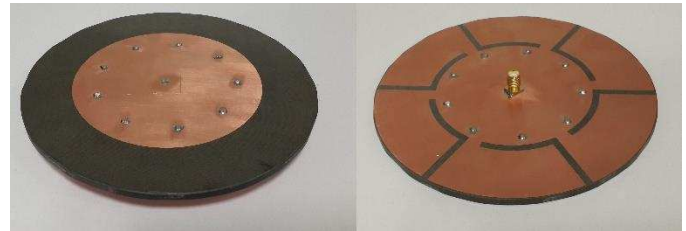

Fig.8. The prototype of proposed omnidirectional LHCP antenna

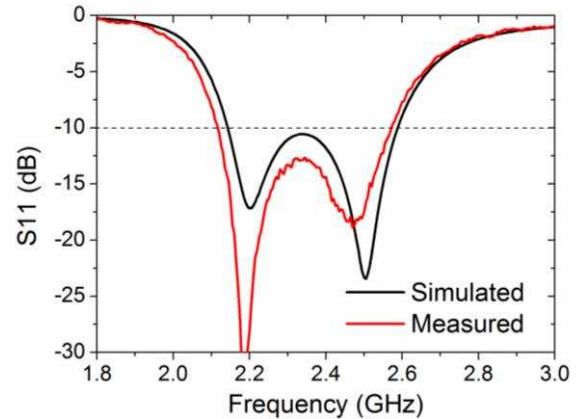

Fig. 9. Simulated and measured  $S_{11}$  of the proposed LHCP antenna

The simulated and measured  $S_{11}$  are plotted in Fig. 9. The measured results show a good agreement with the simulated results. The measured impedance bandwidths, for  $S_{11} < -10$  dB, is 455 MHz (from 2.115 to 2.570 GHz) while the simulated impedance band is 450 MHz (from 2.14 to 2.59 GHz). The first and second resonant frequency at 2.2 GHz and 2.5 GHz for TM<sub>01</sub> and TM<sub>02</sub> modes can be observed.

The simulated and measured axial ratios at  $\theta=40^\circ$ ,  $\varphi=0^\circ$  are plotted in Fig. 10. The measured 3-dB axial ratio bandwidths (ARBW) are 450 MHz (2.10-2.55 GHz), while the simulation is 464MHz. The measured impedance bands are almost within the 3 dB AR band. The overlapped band of 10-dB return loss

and 3-dB AR bandwidth are 464 MHz (simulated) and 435 MHz (measured), representing overall bandwidth of 18.4%. Some discrepancies between the measured and simulated results were due to cable effects, SMA connector, and fabrication imperfection.

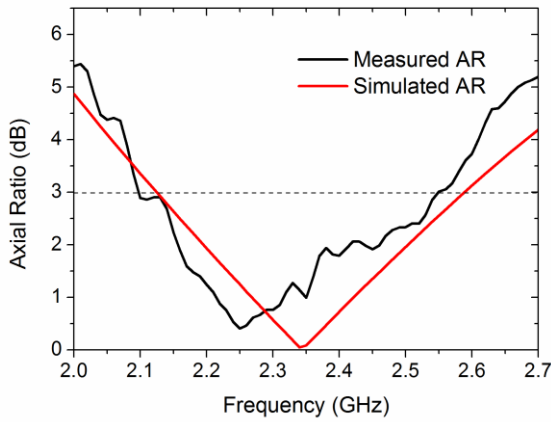

Fig. 10. Simulated and measured axial ratios at  $\theta=40^\circ, \phi=0^\circ$

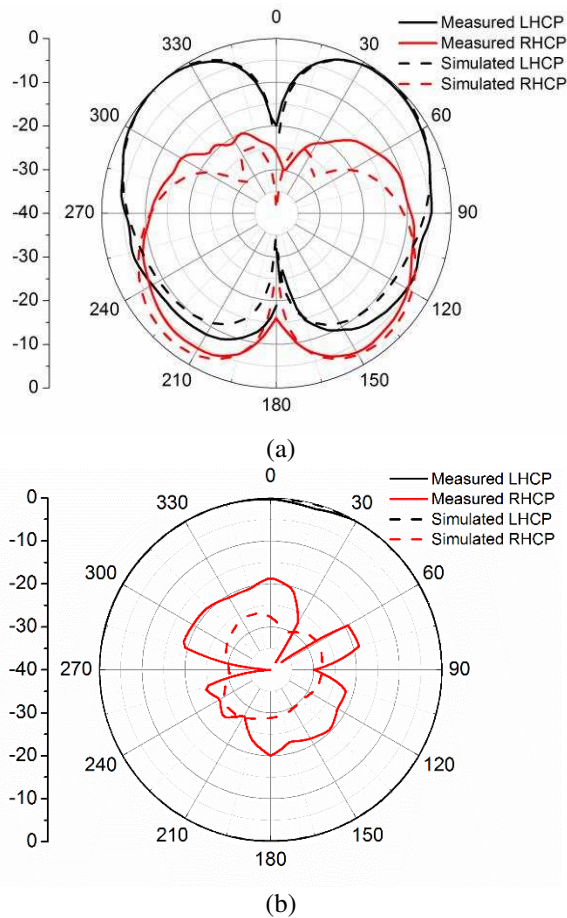

Fig. 11. Simulated and measured radiation patterns in (a) azimuth plane and (b) elevation plane at 2.4 GHz

Fig.11 shows the measured as well as simulated radiation patterns in azimuth and elevation plane at 2.4 GHz. The elevation plane shows a conical pattern. At the elevation angle

of  $40^\circ$ , the antenna has peak gain and LHCP radiation. In broadside direction, antenna has a null radiation. The azimuth plans is well omnidirectional. The antenna gains are steady within  $360^\circ$  azimuth angle. The co-polarized (LHCP) field is at least 18 dB higher than the cross-polarized (RHCP) field showing good purity of the CP radiation.

Fig 12 shows the simulated and measured antenna gains at  $\theta=40^\circ, \phi=0^\circ$ . The simulation and measurement agree well. The gain increases with the increasing frequency. The maximum measured LHCP gain of 3.21 dBic and minimum gain of 0.9 dBic are observed.

#### D. Comparison of omnidirectional CP antenna designs

The performance of various types of omnidirectional CP antennas and the proposed antenna is listed in Table III.

As shown in this Table III, monopole antenna with polarizer array [3], loop radiators array [4] and the wideband CP patch antenna [10] have a larger bandwidth among the conical beam CP antenna. However, designs in [3] and [4] has a higher profile and antenna design in [10] have a large cross section and complex feeding network. The zero order resonance patch antenna [8] and four bended monopoles [9] have low profile, but they have very narrow operational bandwidth that is less than 4%. Although the designs in [12] and [13] have similar performance to proposed LHCP antenna, the proposed antenna achieve more than 50% size reduction.

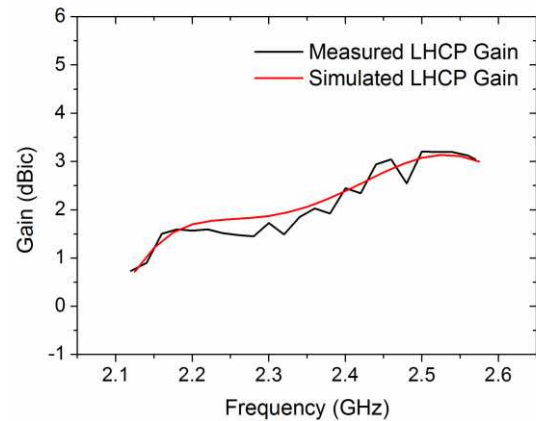

Fig. 12. The simulated and measured antenna gains.

Form the above comparison, it can be concluded that the proposed antenna has a very low profile, wide CP operational band and small cross section with simple structure.

### III. POLARIZATION RECONFIGURABLE CP ANTENNA DESIGN

In this section a polarization reconfigurable omnidirectional antenna is presented. The reconfigurable design is developed based on the antenna shown in Section II.

#### A. Antenna configuration

Fig. 13 shows the configuration of the proposed polarization reconfigurable antennas. It has diameter of 60 mm. Rogers 5880 substrate with relative permittivity of 2.2 and the thickness of 3.125 mm is used in this design. A circular patch radiator is printed on the top of substrate. The ground plane with an annular slot and six radial slots are on

Talbe III  
Performance comparison of omnidirectional CP antenna

Ref. No.	Type of CP antennas	Center frequency	Bandwidth*	Electrical dimension ( $\lambda_0$ at center frequency)	Max gain (dBic)
[1]	monopole	1.62 GHz	2.8%	$0.43\lambda_0 \times 0.43\lambda_0 \times 0.45\lambda_0$	4.5
[2]	slot	12 GHz	NA	$1.93\lambda_0 \times 1.93\lambda_0 \times 0.119\lambda_0$	6.6
[3]	Monopole & polarizer array	5.3 GHz	54.9%	$0.9\lambda_0 \times 0.9\lambda_0 \times 0.43\lambda_0$	6.3
[4]	loop radiators array	2.1 GHz	41%	$0.4\lambda_0 \times 0.4\lambda_0 \times 1.65\lambda_0$	3.7
[5]	DRA with alford loop	2.42 GHz	7%	$0.38\lambda_0 \times 0.38\lambda_0 \times 0.18\lambda_0$	1.8
[6]	Monopole and arc-shaped dipoles	2.45 GHz	4.5%	$0.4\lambda_0 \times 0.4\lambda_0 \times 0.08\lambda_0$	0.5
[7]	Monopole and Loop Radiators	1.65 GHz	11.5%	$0.55\lambda_0 \times 0.55\lambda_0 \times 0.08\lambda_0$	0.86
[8]	Zeroth-Order Resonance patch antenna	1.49 GHz	0.5%	$0.3\lambda_0 \times 0.3\lambda_0 \times 0.016\lambda_0$	-0.4
[9]	four bended monopoles	2.44 GHz	3.56%	$0.22\lambda_0 \times 0.22\lambda_0 \times 0.076\lambda_0$	1.59
[10]	wideband CP patch	2.57 GHz	28.2%	$2.7\lambda_0 \times 2.7\lambda_0 \times 0.1\lambda_0$	5.5
[12]	Monopolar patch with curved branches	2.49 GHz	19.3%	$1.28\lambda_0 \times 1.28\lambda_0 \times 0.024\lambda_0$	4.7
[13]	Monopolar patch with parasitic loop stubs	6.13 GHz	12.2%	$1.16\lambda_0 \times 1.16\lambda_0 \times 0.06\lambda_0$	4.9
Antenna I	Proposed omnidirectional LHCP antenna	2.33 GHz	18.4%	$0.93\lambda_0 \times 0.93\lambda_0 \times 0.024\lambda_0$	3.2

\* Bandwidth is Overlapped bandwidths for 3 dB AR and -10 dB  $S_{11}$

the bottom of substrate. The annular slot separated the ground plane into two part: inner circular ground plane and outer annular ground plane. The diodes are soldered across the annular slot. Then the radial slots divide the outer annular ground plane into 6 pieces and connected by inductors. Furthermore, a small annular slot is curved on outer ground plane with a DC line connected to the inner metal. One inductor is mounted across the small annular slot to chock the high frequency current. The detail value of design parameters are shown in Table II.

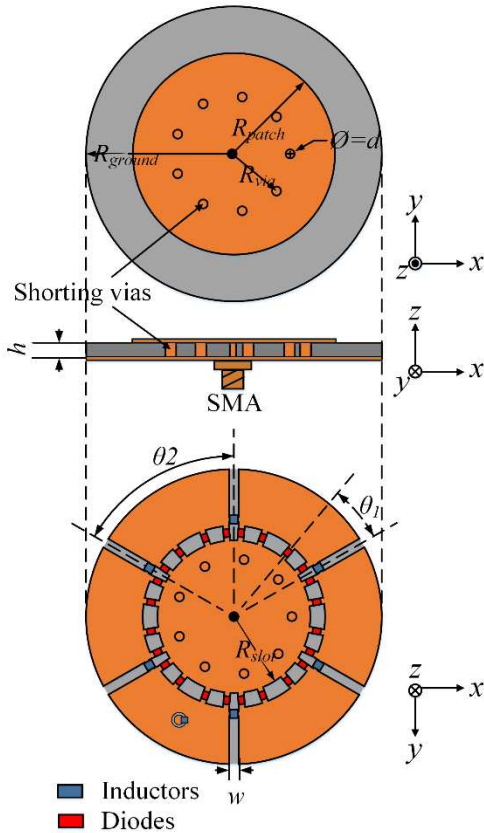

Fig. 13. The geometry of proposed omnidirectional CP antennas

### B. Polarization reconfigurable operational principle

The monopolar patch antenna with bended slots on the ground plane can radiate CP wave as presented in Section II. The horizontal and vertical polarized electrical fields are provided by the surface current in radical direction and  $\phi$  direction as show in Fig.5. Therefore, the CP polarization (LHCP or RHCP) can be switched by changing the orientation of the sequential bended slots.

Diodes are mounted across the annular slot as switches to reconfigurable the orientation of the slot radiator. Fig 14 shows the working principle of the polarization reconfigurable antenna. As shown in Fig. 14 (b), diodes connect the inner circular ground patch and the outer ground patches pointing to different direction at two sides of the radial slot. When the diodes 1 are ON and diodes 2 are OFF, the polarization of reconfigurable antenna is LHCP. Conversely, the polarization is RHCP as shown in fig. 14 (a). PIN diodes SKYWORKS SMP1345-079LF [18] was used in this design due to the very low capacitance and low resistance.

Table II

The parameters of the proposed polarization reconfigurable antenna

$R_{patch}$	$R_{ground}$	$R_{slot}$	$R_{via}$	d
39.5mm	60mm	34mm	30mm	1.6mm
$\theta_1$	$\theta_2$	$\epsilon_r$	h	
20°	60°	2.2	3.175mm	

Six outer ground patches are connected by six inductors which can significantly simplify the DC control circuit. The outer ground patches are electrical connected for DC control. All the diodes can be in parallel connection. However at higher frequency, the impedances of the inductors are very high and the current can be blocked. The inner circular ground patch is electrically connected to the outer conductor of the feeding coaxial cable, so the AC and DC are common grounded. A DC biasing line is connected to the outer ground planes with a small annular slot and inductor chock to achieve



AC /DC isolation. Therefore, only a single DC voltage on the biasing line is required to be applied to all diodes.

The voltage between the outer ground patches and inner ground patch can control the states of the PIN diodes. When negative voltage is applied on the DC biasing line, diodes 1 are ON with diodes 2 OFF leading to LHCP radiation. Otherwise, when positive voltage is applied, diodes 1 are OFF with diodes 2 ON leading to RHCP radiation.

C. Simulated and experimental result

To verify our design concept, a prototype of polarization configurable omnidirectional CP antenna was fabricated, as shown in Fig.15. +5V and -5V DC voltage were applied on the DC biasing line with a 33 Ω series resistor connected.

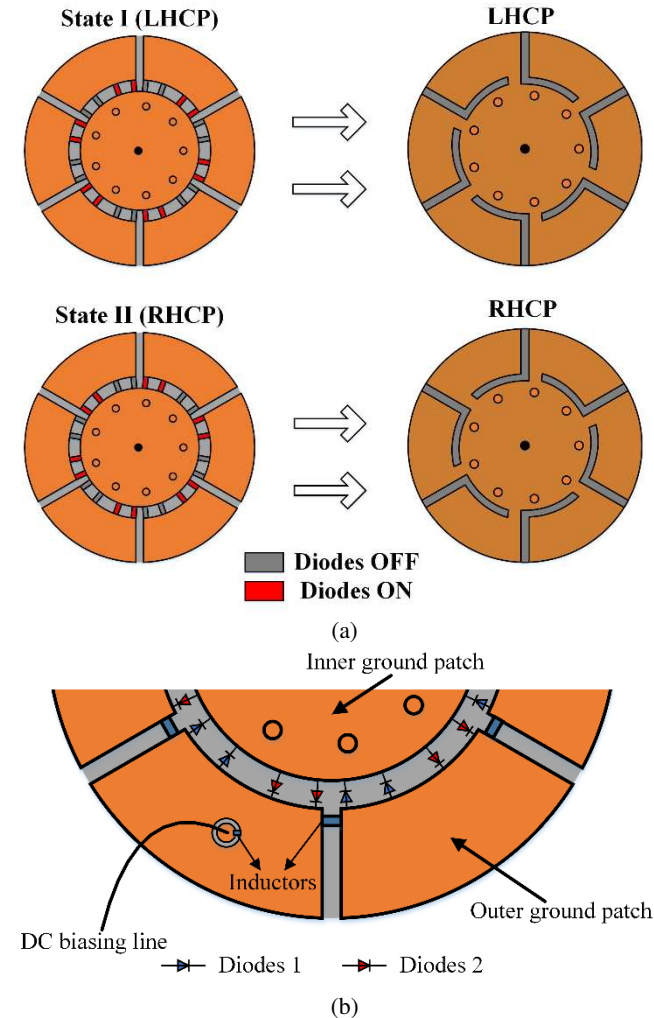

Fig. 14. (a) Working principle of the polarization reconfigurable antenna. (b) PIN diodes and DC biasing circuit

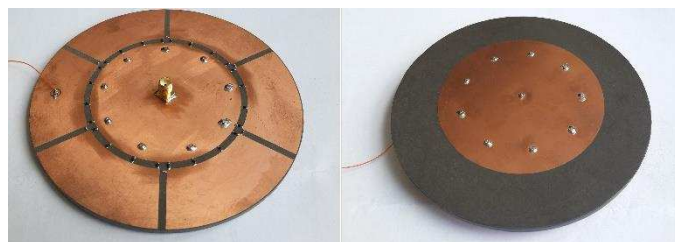

Fig. 15. The prototype of proposed polarization reconfigurable CP antenna

Fig. 16 shows the simulated and measured  $S_{11}$  of the proposed antenna. An ohmic resistance of 1.5 Ω with serial inductance of 0.7 nH and a cutoff capacitance of 0.15 pF with serial resistance of 5 kΩ are used in numerical analyses as the equivalent circuits of the diodes at ON and OFF states, respectively. Measurement shows good agreement with the simulation result. The proposed antenna has two measured impedance bandwidth of 19.8% (2.09 GHz -2.55 GHz) for both states of LHCP mode and RHCP mode.

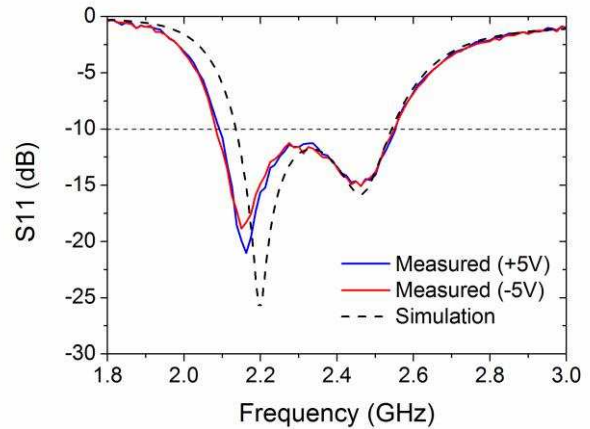

Fig. 16. The simulated measured  $S_{11}$  of the proposed antenna

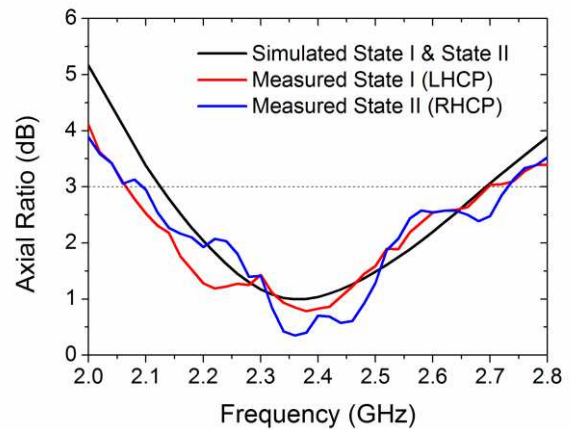

Fig. 17. The simulated and measured AR of polarization configurable CP antenna at  $\theta=40^\circ, \phi=0^\circ$

Measured ARs at elevation angel of  $40^\circ$  are plotted in Fig. 17. It is shown that the prototype had 3dB-AR bandwidths of 25.2% (2.08-2.68 GHz and 2.1-2.72 GHz) for both modes. It can be found that the entire impedance band overlapped within the 3dB-AR band. Therefore the usable bandwidths, which are the bandwidths of the overlapped bands of 3dB-AR and 10dB-return loss, are both 19.8% (2.09 GHz -2.55 GHz).

The simulated and measured radiation patterns for two modes in azimuth and elevation plane are plotted in Fig. 18. The radiation patterns between two states are very similar. At the elevation angel of  $40^\circ$ , the antenna has peak gain and CP radiation. The azimuth plans are well omnidirectional. The antenna gains are stable within  $360^\circ$  azimuth angle. The co-



polarized field is at least 20 dB higher than the cross-polarized field showing good purity of the CP radiation.

The gains of proposed antenna are plotted in fig. 19. The antenna has stable gains across the entire band at both states. Because of the very low profile ( $0.024\lambda$ ) and omnidirectional radiation, the gains of the antenna are from 0.1 dBic to 2.5 dBic within its operational frequency band.

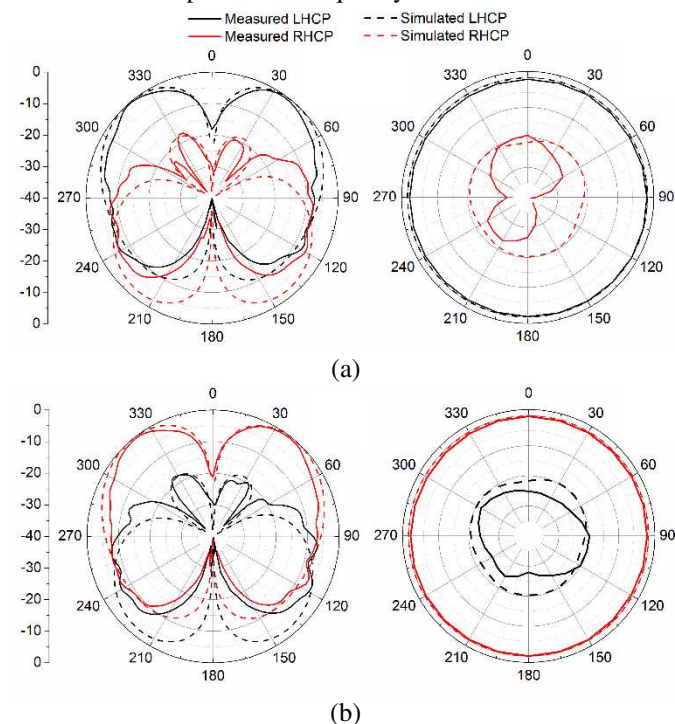

Fig. 18. The simulated measured radiation pattern at 2.4 GHz for (a) State I and (b) State II

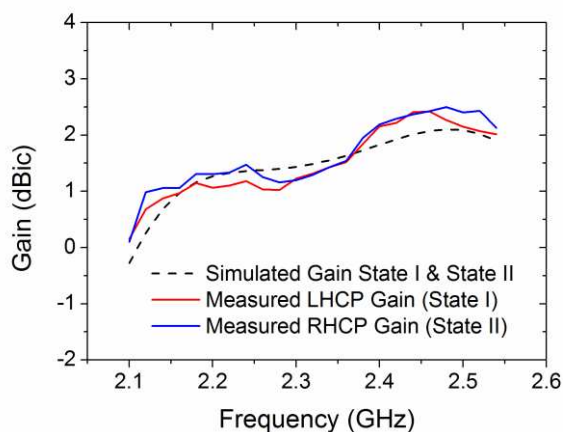

Fig. 19. The simulated and measured antenna gains.

#### IV. CONCLUSION

A novel method of designing omnidirectional circularly polarized antenna is proposed in this paper. By combining the horizontally polarized field generated by the sequential bended slots on the ground plane, and vertical polarized field generated by the microstrip monopolar patch, good CP omnidirectional radiation can be achieved within wide frequency range. The prototype of the proposed conical beam

omnidirectional LHCP antenna was fabricated and measured. Experimental results show that the proposed LHCP antenna exhibits a wide 10-dB impedance bandwidth of 18.4 % from 2.12 to 2.57 GHz and 3dB-axial ratio (AR) bandwidth of 450 MHz. This technique has been further extended to the design of the polarization configurable CP antenna. The effective orientation of bended slot on ground plane can be switched by controlling the states of the PIN diodes. DC control circuit was design to control all the PIN diodes by using single voltage. Good LHCP and RHCP radiations are generated when positive and negative voltage applied. The prototype of proposed polarization reconfigurable antenna was fabricated and measured. Reasonable agreement between the simulation result and measured result has been obtained. Overlapped bandwidths for 3 dB AR and 10 dB return loss of LHCP mode and RHCP mode are both 19.8% (2.09 GHz -2.55 GHz). Stable omnidirectional radiation patterns are observed over the operating bandwidth with pure circularly polarization. The proposed antennas have the advantages of wide CP radiation band, very low profile, compact size and simple structure. The proposed CP antenna can be a good candidate for present wireless communication systems.

#### REFERENCES

- [1] H. Kawakami, G. Sato, and R. Wakabayashi, "Research on circularly polarized conical-beam antennas," *IEEE Antennas Mag.*, vol. 39, pp. 27-39, 1997.
- [2] J.-i. Takada, A. Tanisho, K. Ito, and M. Ando, "Circularly polarised conical beam radial line slot antenna," *Electron. Lett.*, vol. 30, pp. 1729-1730, 1994.
- [3] Y.-M. Pan and K. W. Leung, "Wideband circularly polarized dielectric bird-nest antenna with conical radiation pattern," *IEEE Trans. Antennas Propag.*, vol. 61, pp. 563-570, 2013.
- [4] X. Quan, R. Li, and M. M. Tentzeris, "A broadband omnidirectional circularly polarized antenna," *IEEE Trans. Antennas Propag.*, vol. 61, pp. 2363-2370, 2013.
- [5] W. W. Li and K. W. Leung, "Omnidirectional circularly polarized dielectric resonator antenna with top-loaded Alford loop for pattern diversity design," *IEEE Trans. Antennas Propag.*, vol. 61, pp. 4246-4256, 2013.
- [6] K.-L. Wong, F.-R. Hsiao, and C.-L. Tang, "A low-profile omnidirectional circularly polarized antenna for WLAN access point," in *Proc. Antennas Propag. Soc. Int. Symp.*, 2004, pp. 2580-2583.
- [7] B. Li, S.-W. Liao, and Q. Xue, "Omnidirectional circularly polarized antenna combining monopole and loop radiators," *IEEE Antennas Wireless Propag. Lett.*, vol. 12, pp. 607-610, 2013.
- [8] B.-C. Park and J.-H. Lee, "Omnidirectional circularly polarized antenna utilizing zeroth-order resonance of epsilon negative transmission line," *IEEE Trans. Antennas Propag.*, vol. 59, pp. 2717-2721, 2011.
- [9] Y. Yu, Z. Shen, and S. He, "Compact omnidirectional antenna of circular polarization," *IEEE Antennas Wireless Propag. Lett.*, vol. 11, pp. 1466-1469, 2012.
- [10] K. Lau and K. Luk, "A wideband circularly polarized conical-beam patch antenna," *IEEE Trans. Antennas Propag.*, vol. 54, pp. 1591-1594, 2006.
- [11] J. Liu, Q. Xue, H. Wong, H. W. Lai, and Y. Long, "Design and analysis of a low-profile and broadband microstrip monopolar patch antenna," *IEEE Trans. Antennas Propag.*, vol. 61, pp. 11-18, 2013.
- [12] Y. M. Pan, S. Y. Zheng, and B. J. Hu, "Wideband and Low-Profile Omnidirectional Circularly Polarized Patch Antenna," *IEEE Trans. Antennas Propag.*, vol. 62, pp. 4347-4351, 2014.
- [13] L. Wei and W. Hang, "Circularly Polarized Conical-Beam Antenna With Wide Bandwidth and Low Profile," *IEEE Trans. Antennas Propag.*, vol. 62, pp. 5974-5982, 2014.
- [14] H. Shih-Hsun and C. Kai, "A Novel Reconfigurable Microstrip Antenna With Switchable Circular Polarization," *IEEE Antennas Wireless Propag. Lett.*, vol. 6, pp. 160-162, 2007.

- [15] Q. Pei-Yuan, A. R. Weily, Y. J. Guo, and L. Chang-Hong, "Polarization Reconfigurable U-Slot Patch Antenna," *IEEE Trans. Antennas Propag.*, vol. 58, pp. 3383-3388, 2010.
- [16] Y. Xue-Xia, S. Bing-Cheng, Y. Fan, A. Z. Elsherbeni, and G. Bo, "A Polarization Reconfigurable Patch Antenna With Loop Slots on the Ground Plane," *IEEE Antennas Wireless Propag. Lett.*, vol. 11, pp. 69-72, 2012.
- [17] R. Jeen-Sheen and C. Ming-Che, "Reconfigurable Circularly-Polarized Patch Antenna With Conical Beam," *IEEE Trans. Antennas Propag.*, vol. 58, pp. 2753-2757, 2010.
- [18] "SMP1345 Series: Very Low Capacitance, Plastic Packaged Silicon PIN Diodes DATA SHEET " Skyworks Solutions, Inc, [http://www.skyworksinc.com/uploads/documents/SMP1345\\_Series\\_200046R.pdf](http://www.skyworksinc.com/uploads/documents/SMP1345_Series_200046R.pdf), Online2015.
- [19] L. Shen, S. A. Long, M. Allerdig, and M. Walton, "Resonant frequency of a circular disc, printed-circuit antenna," *IEEE Trans. Antennas Propag.*, vol. 25, pp. 595-596, 1977.