

Comparative Analysis of Mathematical Modeling of Photo-Voltaic (PV) Array

Satarupa Bal, *Student Member, IEEE*, Anup Anurag, *Student Member, IEEE*, and B. Chitti Babu, *Member, IEEE*

Department of Electrical Engineering, National Institute of Technology, Rourkela-769 008 (INDIA)

E-mail: bal.satarupa03@gmail.com, anup.rana123@gmail.com, bcbabunitrkl@ieee.org

Abstract— This paper presents a comparative study between various models of Photo-Voltaic (PV) array which have been formulated exclusively using the data sheet parameters. The models used for comparative study in this paper includes single diode model, the two diode model, the simplified single diode model and the improved single diode model. PV systems are generally integrated with specific control algorithms in order to extract the maximum possible power. Hence it is highly imperative that the Maximum Power Point (MPP) is achieved effectively and thus we need to design a model from which the MPPT algorithm can be realized in an efficient way. Also other parameters should be taken into account for finding the best model for the use in simulator. In this paper, comparisons have been made on basis of the MPP tracking, the RMSD from the experimental data. Further, the resemblance of the P-V and I-V curves as obtained on the basis of experimental data has also been included in this study. On the basis of all these, the best model that can be used for simulation purposes has been selected. It is envisaged that the work can be very useful for professionals who require simple and accurate PV simulators for their design. All the systems here are modeled and simulated in MATLAB/Simulink environment.

Keywords— *Photo-voltaic (PV) array, Equivalent Circuit Modeling, single diode model, two diode model, empirical model*

I. NOMENCLATURE

V_{pv}	: Output voltage of a PV module (V)
T_r	: Reference temperature = 298 K
T	: Module operating temperature in Kelvin
A	: Ideality factor = 1.6
K	: Boltzmann constant = 1.3805×10^{-23} J/K
q	: Electron charge = 1.6×10^{-19} C
R_s	: Series resistance of a PV module
I_{scr}	: PV module short-circuit current = 1.1 A
K_i	: Short-circuit current temperature co-efficient = 0.0017A / C
G	: PV module illumination= 1000 W/m ²
E_{go}	: Band-gap for silicon = 1.1 eV
V_{oc}	: Open-circuit voltage=18 V

II. INTRODUCTION

With the spurt in the use of conventional energy sources, the possibility of their exhaustion and environmental pollution is aggravating. Also global energy consumption is growing exponentially. Thus the very low environmental impact of the renewable energy sources makes them a very attractive solution for a growing demand. Renewable sources of energy

include solar energy, wind energy, geo-thermal energy, tidal energy etc. Among these alternative sources of energy, despite their relatively high cost, the electrical energy from photovoltaic is currently regarded as the prerequisite sustainable resource for both stand alone as well as grid connected applications, since it offers zero input fuel cost, abundant and clean and distributed over the Earth [1].

Nevertheless, this kind of intermittent power generation usually causes problems in the electrical system it is connected to, because of the lack or scarcity of control on the produced active and reactive power. This requires assessment of PV power potential and selection of appropriate PV Module. Several studies have been directed world over on characterization of PV data and site matching of solar energy [2-4]. It is also observed from literature that mathematical models of few individual components of PV system are represented and simulated for better understanding of their performances [5].

The major component that affects the accuracy of the simulation is the PV cell modeling, involves the estimation of the I-V and P-V characteristics curves. Among various mathematical model of PV array proposed in the literature, the simplest is the ideal single diode model which involves only three parameters namely short circuit current, open circuit voltage and the diode ideality factor [6]-[7]. Further the Simplified Single Diode Model (SSDM) is proposed [8] which takes into consideration the effect of the series resistance (R_s). However, it lacked the accuracy when subjected to large temperature variations. It was the improved by the introduction of the Single Diode Model (SDM) which includes the additional shunt resistance (R_p). Although it was so accurate than the previous models, it isn't preferred due to its computational complexity. The accuracy is also deteriorated at low irradiance levels [9]. In order to eliminate its drawbacks the two diode model was proposed in [10] which led to more complexity due to the involvement of more number of parameters. The three diode piecewise linear model was proposed henceforth which accounted for the behavior of mismatched PV panels but it led to increased computational complexity due to presence of three diodes. Recently, a new approach for PV modeling has been proposed that includes the advantages of previous models combining the three main considerations namely simplicity, ease of modeling, and accuracy [11]. However, they does not exist an integrated accurate model of PV array for simulation purposes. The development of PV system has demanded the need of

simulation tools capable of handling mathematical simulations. Simulations have helped the process of developing new systems including power converter, by reducing cost and time. Simulation tools have the capabilities of performing dynamic simulations of such system in a visual environment so as to facilitate the development of new systems.

This paper presents a comparative study between various models of Photo-Voltaic (PV) array formulated exclusively using the data sheet parameters. The models used for comparative study in this paper includes ideal single diode model, the two diode model, the simplified single diode model and the improved single diode model. A typical 19.8W model is simulated and the output characteristics are observed. The comparative study has been made on basis of the MPP tracking, the RMSD from the experimental. Further, the resemblance of the P-V and I-V curves as obtained on the basis of experimental data has also been included in this study. On the basis of all these performance indices, the best model that can be used for simulation purposes has been selected. It is envisaged that the work can be very useful for professionals who require simple and accurate PV simulators for their design. All the systems here are modeled and simulated in MATLAB/Simulink environment.

III. MATHEMATICAL MODELLING OF PV ARRAY

A solar cell is basically a p-n junction fabricated in a thin wafer of semiconductor. Being exposed to sunlight, photons with energy greater than the band-gap energy of the semiconductor create some electron-hole pairs proportional to the incident irradiation [12]. Generally, the I-V characteristics for a PV module composed of series connected cells based on single exponential model is expressed as follows [13]:

$$I_s = I_{ph} - I_o \left[e^{\left(\frac{q(V_{pv} + I_s R_s N_s)}{N_s K T A} \right)} - 1 \right] - \left(\frac{V_{pv} + I_s R_s N_s}{N_s R_{sh}} \right) \quad (1)$$

All the parameters are mostly calculated through sets of non-linear equations [2]-[4].

A. Ideal Single Diode Model (ISDM)

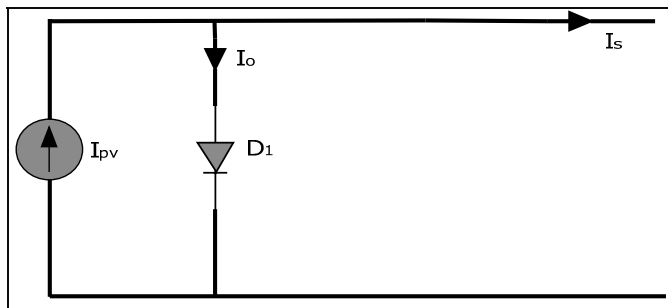

Fig.1. PV cell modeled as ideal single diode circuit

The simplest equivalent circuit of a solar cell is a current source in parallel with a diode as illustrated in Fig.1. The output of the current source is directly proportional to the intensity of light falling on the cell i.e. photocurrent. Here the

diode determines the I-V characteristics of the cell. The accuracy is increased by including temperature dependent diode saturation current (I_0), temperature dependent photocurrent (I_{ph}) and diode ideality factor (A) which lies between 1 and 2.

In an ideal cell $R_s=R_{sh}=0$, which is usually a common assumption.

The equations are given as:

Module Photo-current (I_{ph}):

$$I_{ph} = \frac{[I_{scr} + K_i(T - 298)]G}{1000} \quad (2)$$

Module reverse saturation current (I_{rs}):

$$I_{rs} = \frac{I_{scr}}{e^{(qV_{oc}/N_s K A T)} - 1} \quad (3)$$

Module saturation current (I_0):

$$I_o = I_{rs} \left[\frac{T}{T_r} \right]^3 e^{\frac{qE_{go}}{BK \left(\frac{1}{T_r} - \frac{1}{T} \right)}} \quad (4)$$

Output current (I_{pv}):

$$I_s = I_{ph} - I_o \left[e^{\left(\frac{qV_{pv}}{N_s K T A} \right)} - 1 \right] \quad (5)$$

Here the ideality factor is assumed to be 1.6. However the output curve doesn't give accurate shape between the maximum power point the open-circuit voltage because of the exclusion of R_s . here the leakage current to the ground due to R_{sh} is also excluded.

B. Simplified Single Diode Model (SSDM)

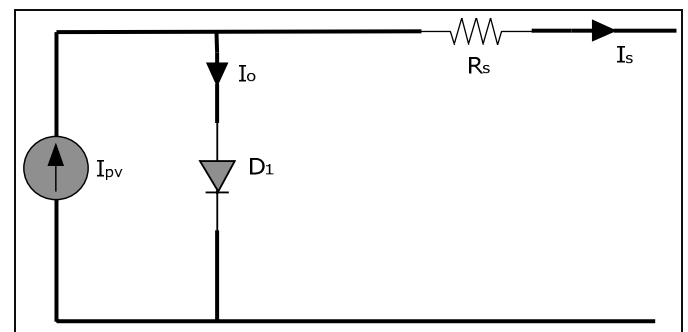

Fig. 2. PV cell modeled as simplified single diode circuit

From the Fig.2, in the simplified single diode model the effect of R_{sh} is neglected for mathematical simplicity. The equation (1) reduces to

$$I_s = I_{ph} - I_o \left[e^{\left(\frac{q(V_{pv} + I_s R_s)}{N_s A K T} \right)} - 1 \right] \quad (6)$$

The typical I-V output characteristics of P-V cell is represented by following equations [11]:

Module photo-current (I_{ph}):

$$I_{ph} = \frac{[I_{scr} + K_i(T - 298)]G}{1000} \quad (7)$$

Module reverse saturation current (I_{rs}):

$$I_{rs} = \frac{I_{scr}}{e^{(qV_{oc}/N_sKAT)} - 1} \quad (8)$$

Module saturation current (I_o):

$$I_o = I_{rs} \left[\frac{T}{T_r} \right]^3 e^{\frac{qE_{go}}{BK \left(\frac{1}{T_r} - \frac{1}{T} \right)}} \quad (9)$$

The current output of PV-module (I_{pv}):

$$I_s = I_{ph} - I_o \left[e^{\frac{q(V_{pv} + I_s R_s)}{N_s K A T}} - 1 \right] \quad (10)$$

C. Improved Single Diode Model (ImSDM)

The improved Single Diode Model is based on the idealized Ideal Single Diode Model. However, in order to cope up with the mathematical complexity it is modeled with an entirely different set of mathematical equations. The computation of these equations avoids the use of a non-linear solver [13]. In the Improved Single Diode Model the effects of R_s and R_{sh} are neglected for mathematical simplicity. The equation (1) reduces to

$$I_{pv} = I_{ph} - I_o \left[e^{\left(\frac{qV_{pv}}{N_s K A T} \right)} - 1 \right] \quad (11)$$

This model basically contains three unknown parameters namely I_{ph} , I_o and A .

We know that

$$V_{oc}(G, T) - V_{oc}(G, T_0) = -|\beta| \Delta T \quad (12)$$

where $V_{oc}(G, T)$ represents the open circuit voltage at T and $V_{oc}(G, T_0)$ represents the open circuit voltage at the reference temperature.

The open circuit voltage formula is derived by substituting $I=0$ in eq (11)

$$V_{oc} = \frac{N_s K T A}{q} \ln \left(\frac{I_{ph}}{I_o} + 1 \right) \quad (13)$$

Substituting for $V_{oc}(G, T)$ and $V_{oc}(G, T_0)$ in eq (13) we get

$$\frac{N_s K T A}{q} \left[T \ln \left(\frac{G(I_{sc} + K_i \Delta T)}{I_o} + 1 \right) - T_0 \ln \left(\frac{G I_{sc}}{I_{rs}} + 1 \right) \right] = -|\beta| \Delta T \quad (14)$$

Rearranging the above equation we get

$$I_o = \frac{e^{\frac{|\beta| \Delta T q}{N_s K T A}} (G(I_{sc} + K_i \Delta T))}{(G I_{sc} / I_{rs} + 1)^{\frac{T_0}{T}} - e^{\frac{|\beta| \Delta T q}{N_s K T A}}} \quad (15)$$

Here we have I_{rs} which can be found by

$$I_{rs} = \frac{I_{sc}}{\left(e^{\frac{qV_{oc}}{N_s K A T_0}} - 1 \right)} \quad (16)$$

Furthermore, the equation for the MPP under STC can be expressed as

$$I_m = I_{sc} - I_{rs} \left(e^{\frac{qV_m}{N_s K A T_0}} - 1 \right) \quad (17)$$

Now the unknown parameter A can be derived by substituting (16) into (17)

$$\frac{I_m}{I_{sc}} = e^{\frac{qV_m}{N_s K A T_0}} - \left(\frac{I_{sc} - I_m}{I_{sc}} \right) e^{\frac{qV_{oc}}{N_s K A T_0}} \quad (18)$$

Thus we can find the unknowns A and I_{sc}

Now I_{ph} is determined by the equation

$$I_{ph} = G(I_{sc} + K_i \Delta T) \quad (19)$$

where G the incident irradiance (kW/m²) is, I_{sc} is the short circuit current at STC (in A), ΔT is the temperature difference between the module temperature and the STC temperature, and K_i is the current temperature coefficient.

Finding the value of the unknowns and replacing in (11) we get the exact modeling of the improved single diode model.

D. Single Diode Model with R_s and R_{sh} (SDM)

From the Fig.3, we include the effect of both R_s and R_{sh} . The equation can be written basically through three points as specified on the data sheet namely the short circuit point, the maximum power point and the open circuit point.

$$I_{sc} = I_{ph} - I_{rs} \left[e^{\left(\frac{qI_{sc} R_s N_s}{N_s K T A} \right)} - 1 \right] - \left(\frac{I_{sc} R_s}{R_{sh}} \right) \quad (20)$$

$$I_{mpp} = I_{ph} - I_o \left[e^{\left(\frac{q(V_{mpp} + I_{mpp} R_s N_s)}{N_s K T A} \right)} - 1 \right] - \left(\frac{V_{mpp} + I_{mpp} R_s N_s}{N_s R_{sh}} \right) \quad (21)$$

$$I_{oc} = I_{ph} - I_o \left[e^{\left(\frac{qV_{oc}}{N_s K T A} \right)} - 1 \right] - \left(\frac{V_{oc}}{N_s R_{sh}} \right) \quad (22)$$

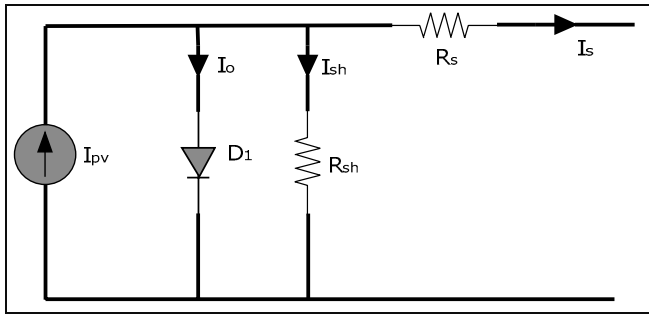

Fig.3. PV cell modeled as single diode circuit including R_s and R_{sh}

Another equation can also be derived using the fact that, at the MPP, the slope of the P-V curve is zero.

$$\frac{dP}{dV} = 0 \text{ at MPP} \quad (23)$$

So far there are four equations available, but there are five parameters to find, therefore a fifth equation has to be found. For this purpose can be used the derivative of the current with the voltage at short-circuit conditions, which is mainly determined by the shunt resistance R_{sh} .

$$\frac{dI}{dV} = \frac{-1}{R_{sh}} \text{ at } I=I_{sc} \quad (24)$$

From the expression of the current at short-circuit and open circuit conditions, the photo-generated current I_{ph} and the saturation current I_o can be expressed:

$$I_{ph} = I_o \left[e^{\left(\frac{qV_{oc}}{N_s KTA} \right)} - 1 \right] - \left(\frac{V_{oc}}{N_s R_{sh}} \right) \quad (25)$$

From eq(25) and (20) we get

$$I_{sc} = I_o \left[e^{\left(\frac{qV_{oc}}{N_s KTA} \right)} - e^{\left(\frac{qI_{sc} R_s N_s}{N_s KTA} \right)} \right] - \left(\frac{V_{oc} - I_{sc} R_s}{N_s R_{sh}} \right) \quad (26)$$

The second term in the parenthesis from the above equation is neglected as it is very less compared to the first term.

$$I_{sc} = I_o e^{\left(\frac{qV_{oc}}{N_s KTA} \right)} - \left(\frac{V_{oc} - I_{sc} R_s}{N_s R_{sh}} \right) \quad (27)$$

Solving for the saturation current we get

$$I_o = I_{sc} - \left(\frac{V_{oc} - I_{sc} R_s}{R_{sh}} \right) e^{\left(\frac{-qV_{oc}}{N_s KTA} \right)} \quad (28)$$

Combining equation (25) (28) and (21) we get

$$I_{mpp} = I_{sc} - \frac{V_{mpp} + I_{mpp} R_s - I_{sc} R_s}{R_{sh}} - \left(I_{sc} - \frac{V_{oc} - I_{sc} R_s}{R_{sh}} \right) e^{\frac{q(V_{mpp} + I_{mpp} R_s - V_{oc})}{N_s KAT}}$$

Now we apply the maximum power point (MPP);

$$\frac{dP}{dV} = I + \frac{dI}{dV} V \quad (30)$$

In order to obtain the derivative of the power at MPP, the derivative of Eq.(29) with voltage should be found. However, since (29) is a transcendental equation, and it is expressed in the form

$$I = f(I, V) \quad (31)$$

Differentiating we get

$$dI = dI \frac{\partial f(I, V)}{\partial I} + dV \frac{\partial f(I, V)}{\partial V} \quad (32)$$

$$\frac{dI}{dV} = \frac{\frac{\partial}{\partial V} f(I, V)}{1 - \frac{\partial}{\partial I} f(I, V)} \quad (33)$$

From (33) and (30)

$$\frac{dP}{dV} = I_{mpp} + \frac{V_{mpp} \frac{\partial}{\partial V} f(I, V)}{1 - \frac{\partial}{\partial I} f(I, V)} \quad (34)$$

From the above equations

$$\frac{dP}{dV} \Big|_{I=I_{mpp}} = I_{mpp} + V_{mpp} \frac{\frac{(I_{sc} R_{sh} - V_{oc} + I_{sc} R_s) e^{\frac{V_{mpp} + I_{mpp} R_s - V_{oc}}{N_s V_t}}}{N_s V_t R_{sh}} - \frac{1}{R_{sh}}}{1 + \frac{(I_{sc} R_{sh} - V_{oc} + I_{sc} R_s) e^{\frac{V_{mpp} + I_{mpp} R_s - V_{oc}}{N_s V_t}}}{N_s V_t R_{sh}} + \frac{R_s}{R_{sh}}} \quad (35)$$

These equations lead to the equation:

$$\frac{-1}{R_{sh}} \Big|_{I=I_{sc}} = \frac{\frac{(I_{sc} R_{sh} - V_{oc} + I_{sc} R_s) e^{\frac{I_{sc} R_s - V_{oc}}{N_s V_t}}}{ns V_t R_{sh}} - \frac{1}{R_{sh}}}{1 + \frac{(I_{sc} R_{sh} - V_{oc} + I_{sc} R_s) e^{\frac{I_{sc} R_s - V_{oc}}{N_s V_t}}}{ns V_t R_{sh}} + \frac{R_s}{R_{sh}}} \quad (36)$$

Now we can determine all the three unknown parameters, the R_s , A , and R_{sh} using the equations. As these equations do not allow separating the unknowns, they are solved using numerical methods.

E. Two Diode Model

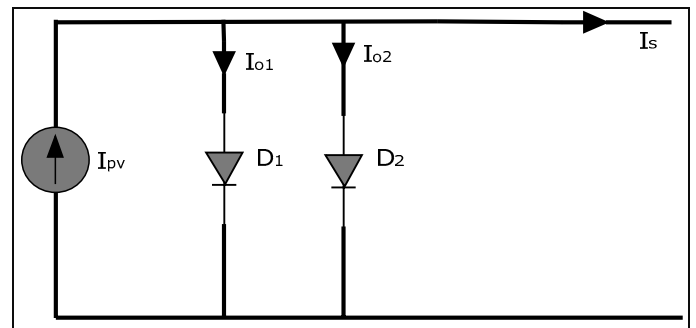

Fig.4. PV cell modeled as two diode circuit

For Two Diode Model, we consider two diodes as shown in the Fig.4. Here we consider the presence of two parallel diodes instead of a single diode as before. It led to increase in accuracy of the model with greater resemblance to experimental data. This model is known to have better accuracy at low irradiance level which allows for a more accurate prediction of PV system performance [14]. To reduce computational time, the input parameters are reduced. Here R_s and R_{sh} are excluded for simplicity.

The output current of the cell may be described as

$$I_{pv} = I_{ph} - I_{d1} - I_{d2} \quad (37)$$

where I_{d1} is the current through diode d_1 and is given by

$$I_{d1} = I_{o1} \left[e^{\frac{V_{pv}}{A_1 V_{T1}}} - 1 \right] \quad (38)$$

And I_{d2} is the current through diode d_2 which is given by

$$I_{d2} = I_{o2} \left[e^{\frac{V_{pv}}{A_2 V_{T2}}} - 1 \right] \quad (39)$$

where I_{o1} is the reverse saturation current of diode 1 and I_{o2} is the reverse saturation currents of diode 2, V_{T1} and V_{T2} are the thermal voltages of diode 1 and diode 2 respectively. A_1 and A_2 represent the diode ideality factors. It requires the computation of five parameters, namely I_{pv} , I_{o1} , I_{o2} , a_1 and a_2 . To simplify, several researchers assumed $a_1=1$ & $a_2=2$.

IV. RESULTS AND DISCUSSIONS

In order to compare various PV models, a small scale PV module of 25 watts is considered. Further, it is modeled and tested in MATLAB/Simulink environment and is compared with the real experimental data (TBP-1125). Table-I gives the parameters used for the simulation study to compare all the models.

TABLE I

PARAMETERS USED IN SIMULATION

Parameter	Label	Value
Maximum Power	P_{max}	25[W]
Open Circuit Voltage	V_{oc}	21.2 [V]
Short Circuit Current	I_{sc}	1.68(A)
Voltage at MPP	V_{mpp}	16.3(V)
Current at MPP	I_{mpp}	1.47(A)

A. Analysis of $P-V_{pv}$ and $I_{pv}-V_{pv}$ Curves

Fig.5 and Fig.6 depicts the typical P-V and I-V characteristics of various PV models at a particular temperature and irradiation. From this, following

interpretations are made. The output curve for *an ideal single diode model* doesn't guarantee accurate shape between the maximum power point and the open-circuit voltage because of the exclusion of R_s and also because of the exclusion of R_{sh} . Hence the graphs deviates completely from the experimental results obtained. For the *single diode model with R_s only*, the model is improved. The graph obtained coincides with the experimental result at I_{sc} and V_{oc} but the MPP deviates greatly for the one obtained from experimental result. It even exhibits serious deficiencies when subjected to temperature variations. For the *single diode model considering both R_s and R_{sh}* , the model is significantly improved and is almost approximated to the actual PV panel but, this approach demands significant computing effort and its accuracy deteriorates at low irradiance, especially in the vicinity of V_{oc} [11]. For the *two diode model*, the graph deviates from the experimental result near the vicinity of I_{sc} but the graph has MPP near to the experimental MPP and the graph between the MPP and V_{oc} is near to the experimental result. However, for the *improved single diode model*, the simulation result coincides closely with the experimental result and exactly at MPP. It takes advantage of the simplicity of ideal models and enhances the accuracy by deriving a mathematical representation, capable of extracting accurate estimates of the model parameters, directly related to manufacturer datasheets [13].

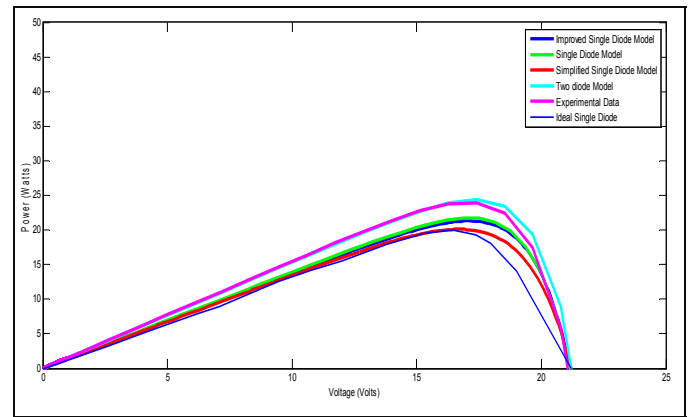

Fig.5. Typical $P-V_{pv}$ output characteristics for different PV equivalent circuits at a particular irradiation and temperature

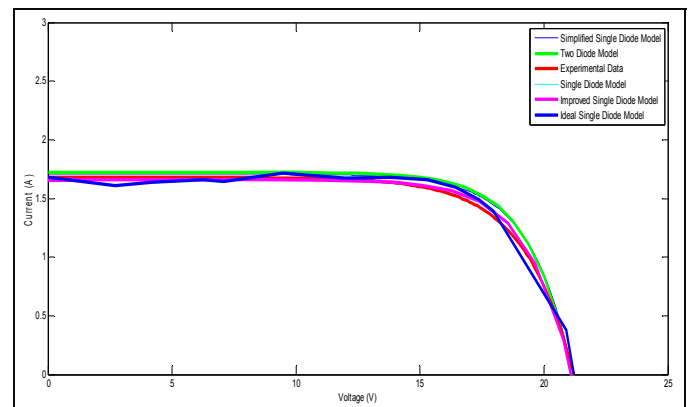

Fig.6. Typical $I_{pv}-V_{pv}$ output characteristics for different PV equivalent models at a particular temperature and irradiation

B. Analysis of the RMSD values

Table-II gives the Root Mean Square Deviation (RMSD) comparison between the various PV models and thus the result clearly shows the order of preference of the model in order to get the approximate graph coinciding closely to the experimental datasheet values at MPP, V_{oc} , I_{sc} . However, the most accurate model is obtained by using the two diode model including R_s and R_{sh} . But because of the tremendous increase in the computation complexity involving seven parameters, it's not used for study [15]. Table-III illustrates the point at which MPP is obtained.

TABLE-II RMSD VALUES FOR DIFFERENT PV EQUIVALENT CIRCUITS

Equivalent Circuit	RMSD
Ideal single diode	0.089(A)
With R_s (SSDM)	0.068(A)
With R_s and R_{sh} (SDM)	0.056(A)
With two-diode	0.0547(A)
With improved single diode	0.053(A)

TABLE-III MPP VALUES FOR DIFFERENT PV EQUIVALENT CIRCUITS

Equivalent Circuit	MPP
Ideal single diode	16.1(V),1.42(A)
With R_s (SSDM)	16.68(V),1.51(A)
With R_s and R_{sh} (SDM)	16.29(V),1.46(A)
With two-diode	16.31(V),1.47(A)
With improved single diode	16.30(V),1.47(A)

V. CONCLUSIONS

The development of PV system has demanded the need of simulation tools capable of handling mathematical simulations. Simulations have helped the process of developing new systems including power converter, by reducing cost and time. In this paper, simulation study for comparative analysis of various mathematical modeling of PV array is discussed. The models discussed here are single diode model, the two diode model, the simplified single diode model and the improved single diode model. For accurate I-V and P-V characteristics with simulation study which encompasses

the theoretical results from data sheet, two diode models gives better results than any other models. As a result, maximum power point (MPP) can be tracked in an effective way. Further, Table-II, reveals that the simplified single diode model has comparable accuracy levels but less simulation time) due to the simplified simulation structure. As a result, SDM method is easy to implement and it is also observed from the study that mathematical models of few individual components of PV system are represented and simulated for better understanding of their performances.

REFERENCES

- [1] J.P. Benner and Kazmerski, "Photovoltaic gaining greater visibility," *IEEE Spectrum*, vol. 29, no. 9, pp. 34–42, Sep. 1999.
- [2] J.P.Lee, B.D. Min, T.J. Kim, D.W.Yoo, and J.Y.Yoo,"Design and Control of Novel Topology for Photo-Voltaic DC/DC Converter with High Efficiency under Wide Load Ranges." *Journal of Power Electronics*, vol.9, no.2, pp.300-307, Mar, 2009.
- [3] H.Altas, A.M.Sharaf, "A photovoltaic array simulation model for MATLAB-Simulink GUI Environment,"Proc. Of International Conference on Clean Electrical Power, ICCEP'07, May 21-23, 2007, Capri, Italy.
- [4] M.A.G. Brito, L.G. Junior, L.P. Sampaio, C.A.Canasin."Evaluation of MPPT Techniques for Photovoltaic Applications", in Proc. of International Symposium on Industrial Electronics - ISIE, 2011,
- [5] W.Xiao, M. G. J. Lind, W. G. Dunford, and A. Capel, "Real-time identification of optimal operating points in photovoltaic power systems," *IEEE Trans. Ind. Electron.*, vol. 53, no. 4, pp. 1017–1026, Jun. 2006.
- [6] D. Chan and J. Phang, "Analytical methods for the extraction of solar-cell single- and double-diode model parameters from i-v characteristics," *Electron Devices, IEEE Transactions on*, vol. 34, no. 2, pp. 286–293, 1987.
- [7] M. G. Villalva, J. R. Gazoli, and E. R. Filho, "Comprehensive approach to modeling and simulating photovoltaic arrays," *IEEE Trans. Power Electron.*, vol. 24, no. 5, pp. 1198–1208, May 2009.
- [8] A.Gow and C. D. Manning, "Development of a photovoltaic array model for use in power electronics simulation studies", *IEEE Proc. Elect. Power Appl.*, vol. 146, no. 2, pp. 193–200, 1999.
- [9] N. Hatziargyriou et. All, "Modeling New Forms of Generation and Storage", *CIGRE Technical Brochure*, 2000.
- [10] F. M. González-Longatt, "Model of photovoltaic module in Matlab," in 2do congreso iberoamericano de estudiantes de ingenieriacute;a eléctrica, electrónica y computación, ii cibelec, 2005, pp. 1–5.
- [11] W.Xiao, H.H. Zeineldin, "A Simple Approach to Modeling and Simulation of Photovoltaic Modules", *IEEE Transaction on Sustainable Energy*, Vol.3, Iss.1, pp.185 – 186.2012.
- [12] G. G. R. Walker, "Evaluating MPPT converter topologies using a matlab PV model," *Journal of Elect. Electron. Eng.*, vol. 21, pp. 49–55, 2001.
- [13] Satarupa Bal, B.Chittii Babu, " Comparative Study between P&O and Current Error Compensation Method for MPPT of PV Energy System", In. *Proc. IEEE Students' Conference on Engineering & Systems (SCES 2012)*, MNNIT, Allahabad, Mar/2012.
- [14] D.Sera, R. Teodorescu, and P. Rodriguez, "PV panel model based on datasheet values," in Proc. IEEE Int. Symp. Ind. Electron. (ISIE), 2007, pp. 2392–2396.
- [15] Z. Salam et al., "An improved two-diode photovoltaic (PV) model for PV system," in Proc. Joint Int. Conf. Power Electron., Drives and Energy Syst., India, 2010, pp. 1–5.