



Comparison Between Oil-Mist and Oil-Jet Lubrication of High-Speed, Small-Bore, Angular-Contact Ball Bearings

Stanley I. Pinel
Pinel Engineering, Fullerton, California

Hans R. Signer
Signer Technical Services, Fullerton, California

Erwin V. Zaretsky
Glenn Research Center, Cleveland, Ohio

The NASA STI Program Office . . . in Profile

Since its founding, NASA has been dedicated to the advancement of aeronautics and space science. The NASA Scientific and Technical Information (STI) Program Office plays a key part in helping NASA maintain this important role.

The NASA STI Program Office is operated by Langley Research Center, the Lead Center for NASA's scientific and technical information. The NASA STI Program Office provides access to the NASA STI Database, the largest collection of aeronautical and space science STI in the world. The Program Office is also NASA's institutional mechanism for disseminating the results of its research and development activities. These results are published by NASA in the NASA STI Report Series, which includes the following report types:

- **TECHNICAL PUBLICATION.** Reports of completed research or a major significant phase of research that present the results of NASA programs and include extensive data or theoretical analysis. Includes compilations of significant scientific and technical data and information deemed to be of continuing reference value. NASA's counterpart of peer-reviewed formal professional papers but has less stringent limitations on manuscript length and extent of graphic presentations.
- **TECHNICAL MEMORANDUM.** Scientific and technical findings that are preliminary or of specialized interest, e.g., quick release reports, working papers, and bibliographies that contain minimal annotation. Does not contain extensive analysis.
- **CONTRACTOR REPORT.** Scientific and technical findings by NASA-sponsored contractors and grantees.

- **CONFERENCE PUBLICATION.** Collected papers from scientific and technical conferences, symposia, seminars, or other meetings sponsored or cosponsored by NASA.
- **SPECIAL PUBLICATION.** Scientific, technical, or historical information from NASA programs, projects, and missions, often concerned with subjects having substantial public interest.
- **TECHNICAL TRANSLATION.** English-language translations of foreign scientific and technical material pertinent to NASA's mission.

Specialized services that complement the STI Program Office's diverse offerings include creating custom thesauri, building customized data bases, organizing and publishing research results . . . even providing videos.

For more information about the NASA STI Program Office, see the following:

- Access the NASA STI Program Home Page at <http://www.sti.nasa.gov>
- E-mail your question via the Internet to help@sti.nasa.gov
- Fax your question to the NASA Access Help Desk at 301-621-0134
- Telephone the NASA Access Help Desk at 301-621-0390
- Write to:
NASA Access Help Desk
NASA Center for AeroSpace Information
7121 Standard Drive
Hanover, MD 21076



Comparison Between Oil-Mist and Oil-Jet Lubrication of High-Speed, Small-Bore, Angular-Contact Ball Bearings

Stanley I. Pinel
Pinel Engineering, Fullerton, California

Hans R. Signer
Signer Technical Services, Fullerton, California

Erwin V. Zaretsky
Glenn Research Center, Cleveland, Ohio

Prepared for the
56th Annual Meeting
sponsored by The Society of Tribologists and Lubrication Engineers
Orlando, Florida, May 20-24, 2001

National Aeronautics and
Space Administration

Glenn Research Center

Available from

NASA Center for Aerospace Information
7121 Standard Drive
Hanover, MD 21076

National Technical Information Service
5285 Port Royal Road
Springfield, VA 22100

Available electronically at <http://gltrs.grc.nasa.gov/GLTRS>

Comparison Between Oil-Mist and Oil-Jet Lubrication of High-Speed, Small-Bore, Angular-Contact Ball Bearings

Stanley I. Pinel
Pinel Engineering
Fullerton, California

Hans R. Signer
Signer Technical Services
Fullerton, California

Erwin V. Zaretsky
National Aeronautics and Space Administration
Glenn Research Center
Cleveland, Ohio 44135

Parametric tests were conducted with an optimized 35-mm-bore-angular-contact ball bearing on a high-speed, high-temperature bearing tester. Results from both air-oil mist lubrication and oil-jet lubrication systems used to lubricate the bearing were compared to speeds of 2.5×10^6 DN. The maximum obtainable speed with air-oil mist lubrication is 2.5×10^6 DN. Lower bearing temperatures and higher power losses are obtained with oil-jet lubrication than with air-oil mist lubrication. Bearing power loss is a direct function of oil flow to the bearing and independent of oil delivery system. For a given oil-flow rate, bearing temperature and power loss increase with increases in speed. Bearing life is an inverse function of temperature, the difference in temperature between the individual bearing ring components, and the resultant elastohydrodynamic (EHD) film thicknesses. Bearing life is independent of the oil delivery system except as it affects temperature. Cage slip increased with increases in speed. Cage slip as high as 7 percent was measured and was generally higher with air-oil mist lubrication than with oil-jet lubrication.

INTRODUCTION

Grease and simple splash lubrication are the lubrication means of preference for most low-speed machinery applications where the bearing speeds are less than 200 000 DN. (DN is a rolling-element bearing speed parameter where D represents the bearing bore in millimeters and N the bearing

inner-ring speed in rpm.) For aircraft engines, turbomachinery, and drive trains, jet lubrication is used both to lubricate bearings and gears and to control their temperature by removing generated heat. In jet lubrication the placement and number of nozzles, the jet velocity, the lubricant flow rates, and the removal of lubricant from the bearing and immediate vicinity are all important for satisfactory operation, Zaretsky (1).

A more effective and efficient means of lubricating rolling-element bearings is under-race lubrication so that increasing the oil flow decreases the ring temperature. Conventional jet lubrication fails to adequately cool and lubricate the inner-race contact because lubricant is thrown centrifugally outward. While increasing flow rate results in carrying away more heat, it also adds to the heat generated from oil churning, Zaretsky (1).

Ring cooling by oil flow at the exterior ring surfaces has been used for many years for high-speed turbomachinery bearings. To achieve speeds of 3 million DN with angular-contact ball bearings and cylindrical roller bearings, Zaretsky et al. (2) and Signer et al. (3) proposed the concept of "bearing thermal management" as the proper technological approach to high-speed bearing operation. Bearings lubricated through the inner ring passages were also provided with cooling of the external outer ring surfaces. The basis of this concept was the recognition that total and flexible thermal control over the bearing components was essential to achieving a reliable high-speed, highly loaded bearing, Zaretsky (1).

Both the conventional jet and the under-ring lubrication systems recirculate the oil used as the lubricant. There are rotating machinery applications in which a nonrecirculating lubrication system, which operates with minimum possible oil flow, could be employed advantageously. Weight and cost reduction of the system might be realized. One such lubricating system that has been used commercially for decades is air-oil mist lubrication. Oil-mist lubrication systems have been used extensively for industrial applications, high-speed machine spindles, and in limited aerospace applications. Bloch and Shamim (4) describe these oil-mist lubrication systems together with performance data.

Early work by Schuller and Anderson (5,6) studied and determined the effects of minimum oil flow with air-oil mist lubricated, thrust-loaded, 75-mm angular-contact ball bearings to 1.2×10^6 DN under varying loads, oil-flow rates and temperature. They found that the bearings operated satisfactorily at very low oil flows with air-oil mist lubrication using a synthetic diester lubricant (MIL-L-7808). Minimum oil-flow requirements increased with increases in load and speed. They developed for an air-oil mist lubrication system an empirical formula relating minimum oil-flow requirements as a function of load and speed for successful ball bearing operation.

Research performed by Morrison et al. (7) with 45-mm angular-contact ball bearings run to speeds of 135 000 DN run with sump lubrication and air-oil mist found that the air-oil mist lubrication system resulted in lower bearing temperatures on the order of 12 to 15 °C (22 to 27 °F). Shamim and Kettleborough (4,8) also compared an air-oil mist lubrication system with a conventional sump lubrication system for 60-mm-bore-angular-contact ball bearings run to speeds of 144 000 DN. Their results were similar to those of Morrison et al. (7) where the air-oil mist lubricated bearing ran 10 °C (18 °F) cooler than the sump lubricated bearing and at a lower power loss.

Rosenlieb (9) performed once-through, air-oil mist lubrication studies with 125-mm-bore-angular-contact ball bearings made from AISI M-50 steel. The lubricants used in his study were two synthetic paraffinic hydrocarbon fluids and a Type II advanced ester fluid. He demonstrated the feasibility of air-oil mist lubrication to speeds of 2.5×10^6 DN at bearing temperatures of 216 °C (420 °F) for periods of time up to 35 hr at an oil-flow rate as low as 3.7×10^{-3} l/min. Increasing the air-oil mist temperature resulted in an equal increase in bearing temperature.

In a follow-on study, Rosenlieb (10) demonstrated that an air-oil mist system along with auxiliary air cooling could provide short-term operation of a 46-mm-bore-angular-contact ball bearing to speeds up to 3×10^6 DN and temperatures up to 264 °C (505 °F) with flow rates as low as 0.9×10^{-3} l/min. However, at speeds greater than 2.5×10^6 DN bearing cage instability and wear occurred. The cage instability occurred only with oil-mist lubrication and not with oil-jet lubrication. He attributed the cage instability

to the reduced oil damping provided by the air-oil mist. The lubricants used in this study were two different Type I esters meeting the MIL-L-7808 specification, a Type II ester meeting the MIL-L-23699 specification, and a polyphenylether. Rosenlieb (10) also ran air-oil mist bearing lubrication endurance tests at 2×10^6 and 2.5×10^6 DN for 100 and 50 hr, respectively.

Jeng and Huang (11) compared the temperature rise of hybrid ceramic and steel 50-mm-bore-angular-contact ball bearings run to 750 000 DN. For their tests they varied load, speed, airflow rate, and oil quality. Their test results compared well with those of Schuller and Anderson (5,6). Increasing the airflow rate for a constant lubricant flow marginally reduced bearing temperature. Bearing temperature increased with speed and to a lesser extent with load and decreased lubricant flow rate. The hybrid ceramic bearing ran at lower temperatures than the steel bearing by 4 to 8 °C (7 to 14 °F). However, as the lubricant flow rate is increased, the temperature difference becomes inconsequential. This can be attributed to the volume of oil entrapped in the bearing beyond that necessary for elastohydrodynamic lubrication (EHD). Initially, the smaller Hertzian contact ellipse with the hybrid ceramic bearing results in lower frictional losses. Churning of the oil at the higher flow rates accounts for the major frictional loss in the bearing resulting in both bearing types having similar temperature values.

In Pinel et al. (12) we reported the results of our research with high-speed, small-bore, angular-contact ball bearings run to 2.5 million DN with both oil jet and under inner-ring lubrication. The results of this research optimized the design of oil-jet lubricated 35-mm-bore-angular-contact ball bearings to a single-outer-ring, land-guided cage with a 24° contact angle with a relieved inner ring and a partially relieved outer ring. This design resulted in lower temperature and power loss.

The objectives of the work reported herein are to (1) extend our work with the 35-mm-bore-angular-contact ball bearings to include the effect of air-oil mist lubrication; (2) define and extend ball bearing operating limits with air-oil mist lubrication; and (3) compare air-oil mist lubricated angular-contact ball bearing operation with oil-jet lubricated bearings to 2.5×10^6 DN.

APPARATUS, SPECIMENS, AND PROCEDURE

High-Speed Bearing Tester

A schematic drawing of the air-turbine-driven test machine is shown in Fig. 1(a) and was initially described by Pinel and Signer (13). The test rig consisted of a horizontally mounted shaft supported by two preloaded, angular-contact ball bearings. The test bearing was overhung and mounted in a separate housing (Fig. 1(b)) that incorporated the hardware for lubrication, oil removal, thrust load application, and instru-

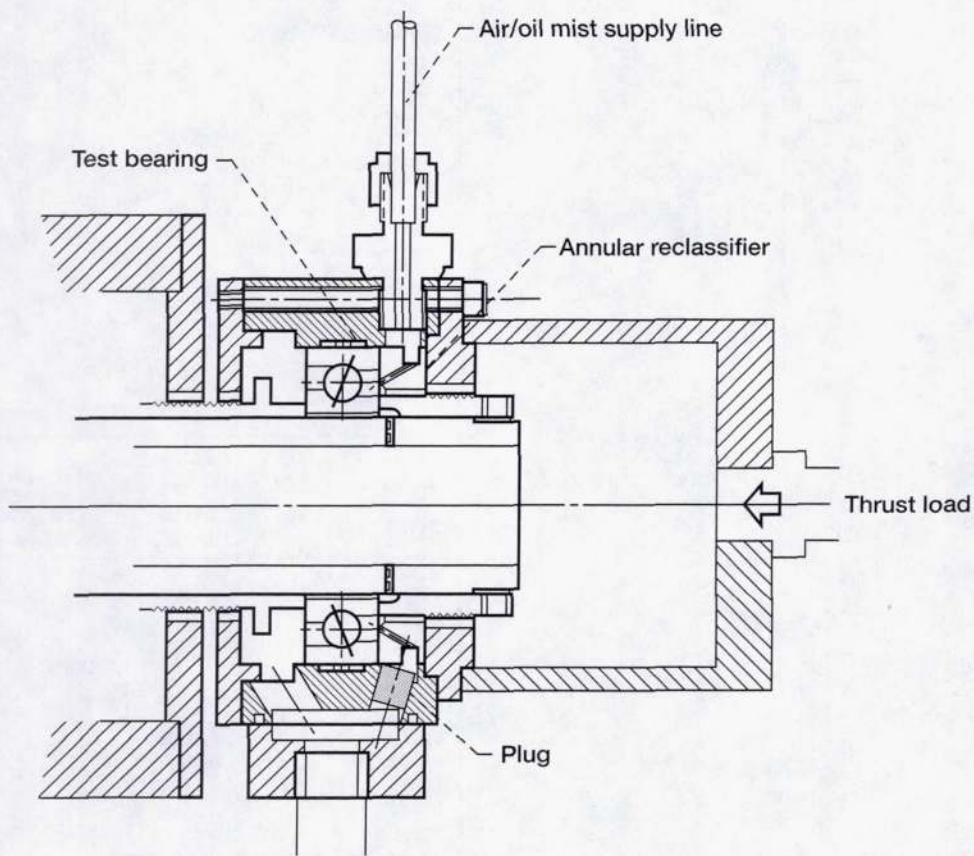
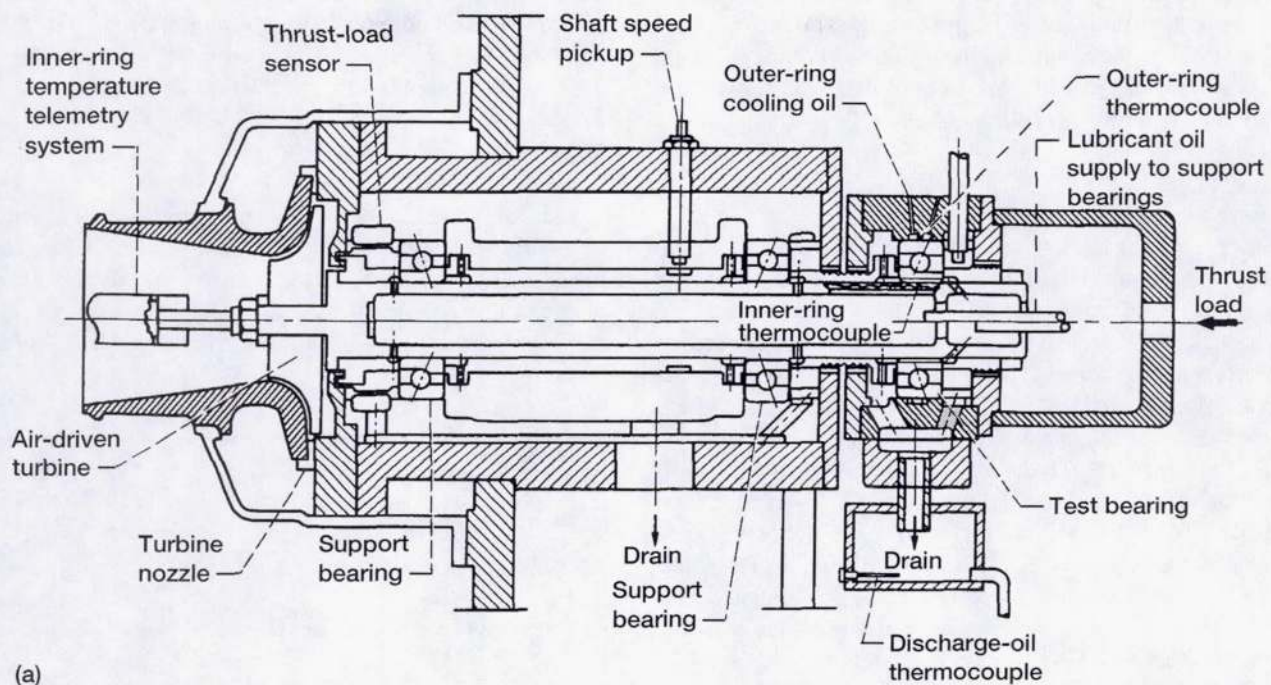

Figure 1.—High-speed, small-bore-bearing tester. (a) Schematic. (b) Test bearing installation.

mentation for cage speed measurement. The test-bearing torque was measured with strain gages located near the end of an arm that prevented the housing from rotating. Thrust force was applied through the combination of a thrust needle bearing and a small roller support bearing to minimize test-housing restraint during torque measurements.

Test Bearing

Based upon the work reported in Pinel et al. (12), a 35-mm-bore-angular-contact ball bearing with relieved inner and partially relieved outer rings, a 24° unmounted contact angle, and a single-outer-ring, land-guided cage (Fig. 2) was used for the tests reported herein. The specifications for the test bearings are summarized in Table 1. The bearings were an ABEC 7 grade and each contained 16 balls with a nominal 7.14-mm (0.281-in.) diameter. The inner and outer rings and the balls were manufactured from consumable-electrode, vacuum-melted, AISI M-50 steel. The surface finishes of the races were 0.125 μm (5 μin.) rms or better. The surface finish of the balls was 0.025 μm (1 μin.). The bearing surface composite finish was 0.130 μm (5.1 μin.). The nominal hardness of the balls and rings was Rockwell C62 at room temperature.

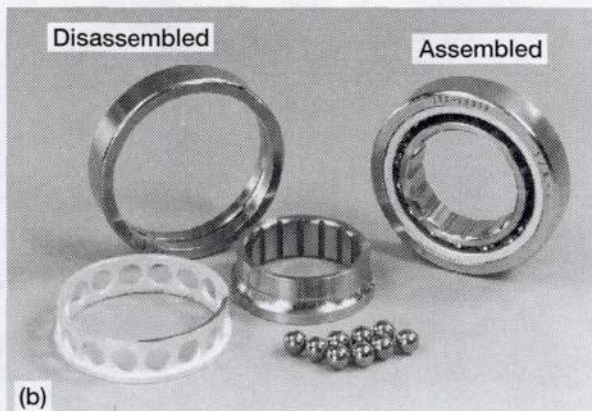
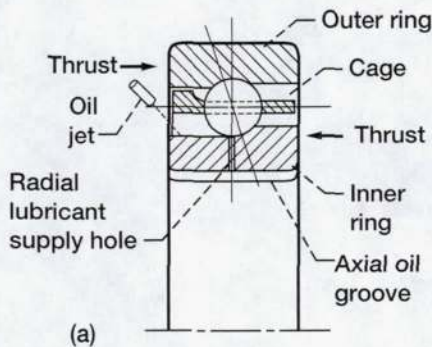

Figure 2.—35-mm-bore, angular-contact ball bearing with relieved inner ring (design 4). (a) Single outer-ring, land-guided cage. (b) Bearing assembly.

The cage was manufactured from AISI 4340 steel (AMS 6415) heat-treated to Rockwell C 28 to 36 hardness. It was completely coated with a 0.02- to 0.04-mm (0.0008- to 0.0015-in.) thickness of silver plate (AMS 2412). The cage balance was within 0.50 g-cm (7×10^{-3} oz-in.).

Lubricant

The lubricant used for the parametric studies was a neopentylpolyol (tetra) ester. This Type II oil is qualified to the MIL-L-23699 specifications and also to the internal oil specifications of most major aircraft engine manufacturers. The major properties of the lubricant are presented in Table 2.

TABLE 1.—TEST BEARING SPECIFICATIONS

Bearing	
Bore, mm (in.)	35 (1.3780)
Outside diameter, mm (in.)	62 (2.4409)
Width, mm (in.)	14 (0.5512)
Grade	ABEC 7
Surface composite finish, μm (μin.)	0.130 (5.1)
Cage	
Diametral land clearance, mm (in.)	
Outer-land-guided	0.406 (0.016)
Inner-land-guided	0.254 (0.010)
Diametral ball pocket clearance, mm (in.)	0.660 (0.026)
Material	AISI 4340 per AMS 6415 (silver plated)
Hardness Rockwell C	32 to 38
Balls	
Number	16
Size (diam), mm (in.)	7.14 (0.281)
Grade	10
Material	CEVM AISI M-50 per AMS 6490
Hardness, Rockwell C (nominal)	62 (min.)
Surface finish, μm (μin.) rms	0.025 (1)
Race	
Conformity, percent	
Inner	54
Outer	52
Surface finish, μm (μin.) rms	0.125 (5)
Nominal contact angle, deg	24
Internal diametral clearance (IDC), μm (μin.)	
Relieved inner race	0.074 (0.0029)

TABLE 2.—PROPERTIES OF NEOPENTYLPOLYOL (TETRA) ESTER LUBRICANT

Additives	
Corrosion and oxidation inhibitors and antiwear and antifoam additives	
Kinematic viscosity, cS, at—	
38 °C (100 °F)	28.5
99 °C (210 °F)	5.22
204 °C (400 °F)	1.31
Flashpoint, °C (°F)	260 (500)
Autogenous ignition temperature, °C (°F)	421 (800)
Pour point, °C (°F)	-59 (-75)
Volatility (6.5 hr at 204 °C (400 °F)), wt%	3.2
Specific heat at 99 °C (210 °F), J/kg·°C (Btu/lb·°F)	2140 (0.493)
Thermal conductivity at 204 °C (400 °F), J/m·sec·°C (Btu/hr·ft·°F)	0.13 (0.075)
Specific gravity at 99 °C (210 °F)	0.931
Specification	MIL-L-23699

Test Procedure

After the test machine had been warmed by recirculating heated oil through the support bearings, the torque-measuring system was calibrated and a 667-N (150-lbf) thrust load was applied to the test bearing. The shaft speed was then slowly brought up to a nominal speed of 28 000 rpm. When the bearing and test machine temperatures stabilized (after 20 to 25 min), the oil-inlet temperature and lubricant flow rate were set and the speed was increased to the desired value.

A nominal thrust load of 667 N (150 lbf) was used for these tests. For each condition, tests were run at nominal speeds of 30 000, 50 000, and 65 000 rpm. A test series was run by starting at the lowest nominal speed, 30 000 rpm, and progressing through 50 000, and 65 000 rpm before changing the lubricant flow rate. During testing, if it became apparent that the conditions would result in predictable distress of the test bearing or test rig or that the bearing temperature would exceed a predetermined temperature, the test point was aborted. Limiting ring temperature was set at 218 °C (425 °F) for the recirculating oil-jet lubrication. A higher ring temperature limit of 260 °C (500 °F) was chosen for air-oil mist lubrication, as some degradation of the lubricant was permissible for a "once through" lubrication system.

The shaft speed (inner-ring speed) was measured with a magnetic probe. The ball-pass frequency (cage speed) was measured with a semiconductor strain gage mounted in a cavity of the housing and was displayed on a spectrum analyzer.

Two thermocouples were assembled in the shaft so that the centrifugal force would push them against the test-bearing inner ring. Temperature readings were transmitted with a rotating telemetry system mounted on an auxiliary shaft at the air-turbine end of the test machine. Outer-ring temperatures were obtained by two thermocouples located 180° from each other.

Lubrication System

Air-Oil Mist—A schematic diagram of the air-oil mist lubrication system used for these tests is shown in Fig. 3. The air-oil mist system used was identical to that described by Schuller and Anderson (5). By flowing pressurized air into a venturi, the pressure in the venturi is reduced below that in the reservoir and oil is siphoned from the reservoir into the venturi. The oil in the venturi is atomized into a fine mist and carried into an annular reclassifier and into the bearing. Figure 1(b) shows the annular reclassifier and a cross section of the test bearing installation. The drain on the reclassifier side is plugged so as to force the air-oil mist through the reclassifier tubes and through the bearing.

The oil flow to the test bearing was regulated by air pressure to the lubrication tank and selection of the size of the capillary. The oil temperature was controlled by regulating the oil tank wall temperature. The average oil-in temperature was 49 °C (120 °F) at the venturi entrance.

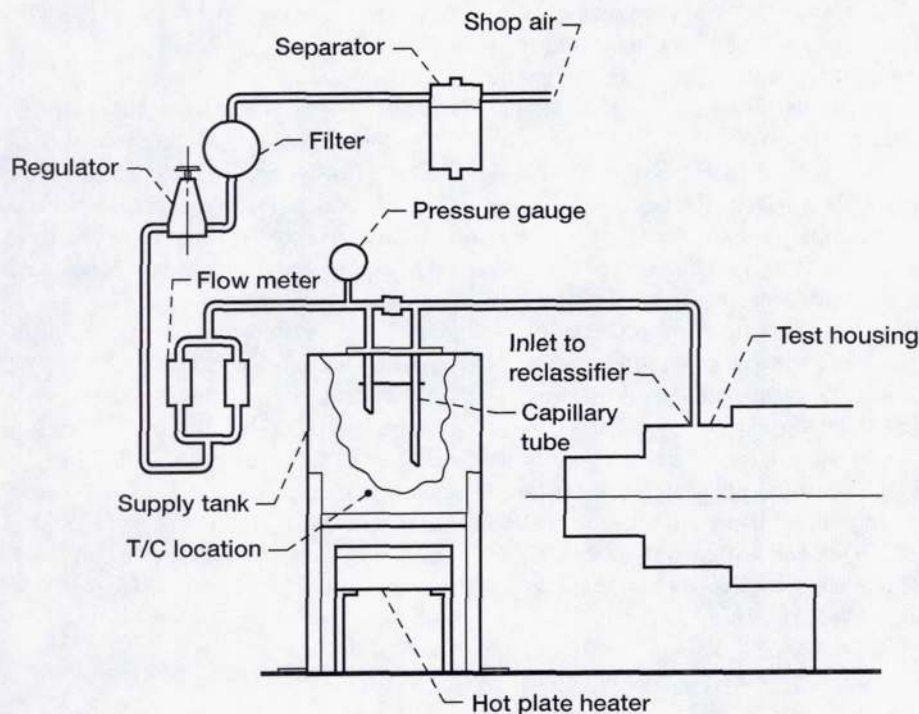

Figure 3.—Air-oil mist lubrication system.

Oil Jet—For jet lubrication, the test bearing was lubricated by two jets on the nonloaded side of the inner ring. The jet outlets, located approximately 3 mm (0.12 in.) from the face of the bearing, were aimed at the inner raceway. In separate tests not reported herein, it was determined that a 20-m/sec (66-ft/sec) jet velocity provided the most efficient test bearing lubrication so this velocity was used in all the tests reported. The oil-in temperature measured just before the oil jet was 121 °C (250 °F) (12).

RESULTS AND DISCUSSION

Effect of Lubricant Flow Rate

Our experience with oil-jet lubrication has shown that the measured bearing temperature after the bearing reaches thermal equilibrium is a function of the bearing load, speed, oil-in temperature, oil-flow rate and volume of oil entrapped in the bearing. At thermal equilibrium, the bearing race temperatures without inner and/or outer ring cooling will always be higher than the oil-in temperature. As the oil-flow rate is increased, the bulk bearing temperature should approach the oil-in temperature. That is, the ring temperature minus the oil-in temperature should diminish up to the point where the heat generated due to power loss from increasing oil churning exceeds the convective cooling capacity of the oil. All oil-flow rates reported herein were kept well below this critical point.

In our experiments, we used two different oil-in temperatures, 49 °C (120 °F) and 121 °C (250 °F) for air-oil mist and oil-jet lubrication, respectively. These temperatures were selected as perhaps being representative of what may be used in high-speed turbomachinery applications. Thus, in our tests the temperature of the oil-jet lubricated bearing can never be less than 121 °C (250 °F). Similar experience or data did not exist for air-oil mist lubrication.

A comparison of the experimental results is shown in Fig. 4 for the test bearing for both the air-oil mist lubrication and oil-jet lubrication. The measured inner- and outer-ring temperatures decreased as lubricant flow rate increased for both lubrication methods. Because the heat transfer to the lubricant is a function of the mass flow rate of the oil to bearing, the resultant bearing temperature at constant operating conditions is a function of the lubricant flow rate and the oil-in temperature independent of the oil delivery system.

Referring to Fig. 4(a), because of the lower flow rate to the bearing at 65 000 rpm with air-oil mist lubrication, the bearing ring temperatures are higher than those with jet lubrication even though the oil-in temperature with air-oil mist is 72 °C (130 °F) lower. These temperatures exceed our temperature limitation for oil-jet lubrication of 218 °C (425 °F).

Bearing temperatures of approximately 190 °C (374 °F) at 50 000 rpm with air-oil mist flow rates between 0.02 and 0.04 ℓ/min are equivalent to those temperatures with an oil-jet flow rate of 0.08 ℓ/min. At 0.04 ℓ/min, the bearing temperature at a speed of 30 000 rpm is approximately the same as with that obtained with jet lubrication at 2 ℓ/min.

Referring to Fig. 4(b), the difference between ring temperature and oil-in temperature is shown as a function of lubricant flow rate. These are the same data as those of Fig. 4(a) but independent of oil-in temperature. As previously discussed, bearing temperature is an inverse function of lubricant flow rate and independent of the lubricant delivery system. It can be reasonably concluded that a specified bearing temperature can be maintained with less oil flow using air-oil mist providing the oil-in temperature is kept low. However, at the higher speed of 65 000 rpm ($2.3 \times 10^6 DN$), the air-oil mist lubrication system becomes marginally effective to maintain bearing temperature. This necessitates the need to use either oil-jet lubrication or under-ring lubrication (Pinel et al. (12)).

For air-oil mist lubrication, the inner-ring temperature is higher than that of the outer ring. This difference in temperature between the inner and outer rings was nominally less than 12 °C (22 °F). Higher heat generation would be expected at the ball inner-race Hertzian contact because of the contact kinematics.

For oil-jet lubrication, the outer-ring temperature is higher than the inner-ring temperature. The same relation was reported in Pinel et al. (12) for under-ring lubrication. At a flow rate of 0.09 ℓ/min at 50 000 rpm, the outer-ring temperature is less than 18 °C (32 °F) higher than that of the inner ring. As lubricant flow rate is increased the temperature decreases and the inner- and outer-ring temperatures become nearly equal as shown in Fig. 4(a).

The lubricant jets were aimed directly at the bearing inner raceway surface. The lower inner-ring temperatures for the jet and the inner-ring lubrication methods may be explained by more effective convective cooling.

Referring to Fig. 5, bearing power loss as a function of oil-flow rate is shown for both air-oil mist and oil-jet lubrication. The power loss data is based on mechanical measurements of bearing torque. Because of low oil flow with the air-oil mist lubrication system, it was not possible to thermally determine power loss. We reported in Pinel et al. (12) that because of the differences in measurement techniques, the thermal measurements were consistently 0.2 kW (0.3 hp) higher than those determined mechanically with oil-jet lubrication. These data show that the power loss is a function of oil flow to the bearing and, for these tests, independent of the delivery system. Because a smaller oil flow is delivered with the air-oil mist system, the power loss is lower than that obtained with oil-jet lubrication.

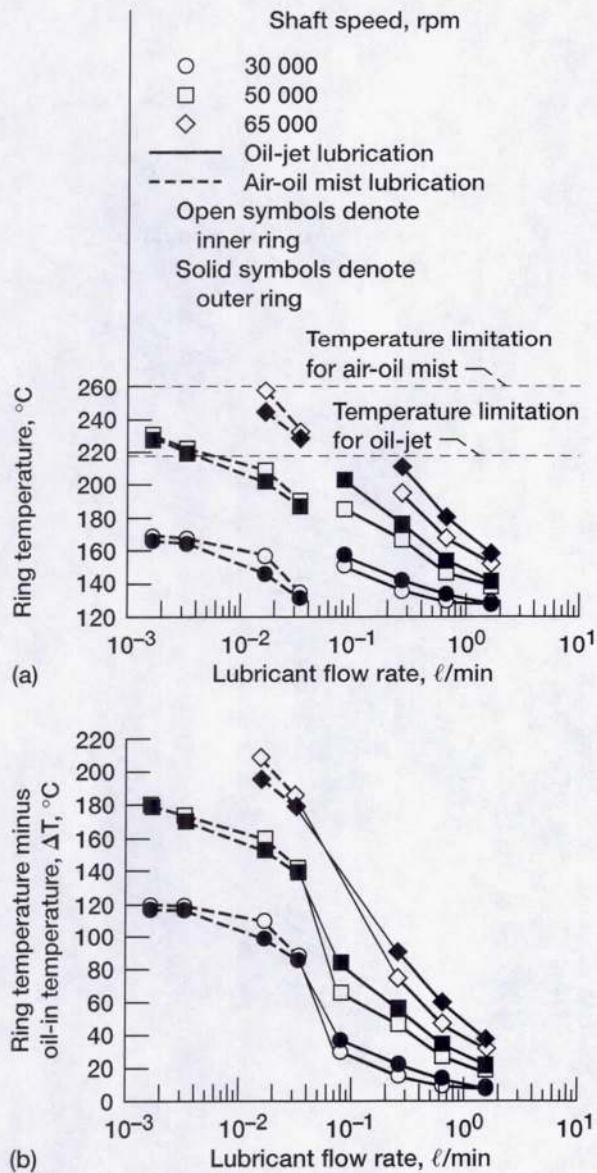

Figure 4.—Effect of lubricant flow rate on bearing temperature for 35-mm bore angular-contact ball bearing lubricated by air-oil mist and oil jet. Thrust load, 667 N (150 lbf); nominal contact angle, 24°; cage, single outer-land guided; oil-in temperature, 49 °C (120 °F) for air-oil mist, 121 °C (250 °F) for oil jet. (a) Measured ring temperatures. (b) Difference between ring temperature and oil-in temperature.

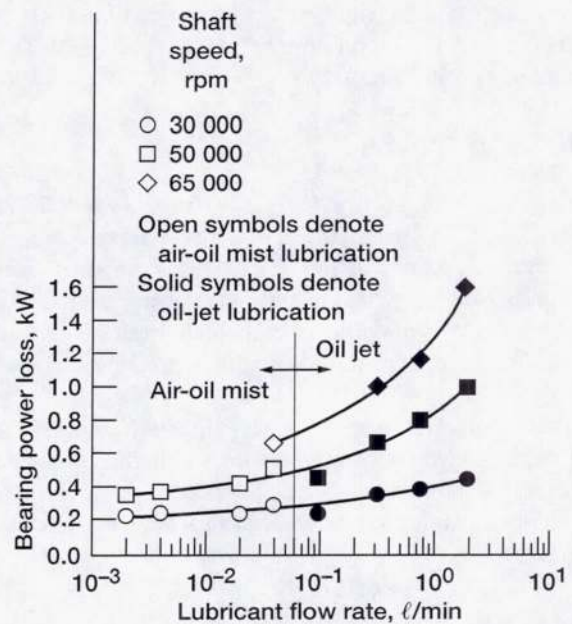

Figure 5.—Effect of lubricant flow rate on bearing power loss for 35-mm bore angular-contact ball bearing lubricated by air-oil mist and oil jet. Thrust load, 667 N (150 lbf); nominal contact angle, 24°; cage, single outer-land guided; oil-in temperature, 49 °C (120 °F) for air-oil mist, 121 °C (250 °F) for oil jet.

Effect of Speed

Figure 6 shows the effect of speed on bearing temperature and power loss. For a given oil-flow rate, bearing temperature and power loss increase with increases in speed, independent of the lubrication delivery system. Referring to Fig. 4(a), air-oil mist lubrication results in high-bearing temperature because of a lower volume of oil delivered to the bearing than with oil jet. However, at 50 000 rpm, the lower power loss is approximately a third of that obtained for oil-jet lubrication and, from Pinel et al. (12), for under-ring lubrication. From the data reported herein and those of Rosenlieb (9,10), it can be reasonably concluded that where the bearing temperature rise is solely caused from heat internally generated from within the bearing cavity, the maximum obtainable speed with air-oil mist lubrication is $2.5 \times 10^6 DN$.

Minimum Oil Flow

Referring to Fig. 4(a), for air-oil mist lubrication, at $2.3 \times 10^6 DN$ (65 000 rpm), the minimum oil flow necessary to maintain a temperature of 260 °C (500 °F) was approximately 0.02 ℓ/min. No attempt was made in these tests to determine at the other speeds a minimum or threshold flow rate below which the bearing temperature would exceed a temperature of 260 °C (500 °F).

Schuller and Anderson (5,6) developed an empirical formula which we reconstituted relating minimum oil-flow requirements as a function of load and speed for successful ball bearing operation for an air-oil mist lubrication system where

$$V = k[P^{4.22} \times 10^{1.18(S-8)}] \quad (1)$$

Where

V	oil-flow rate, ℓ/min
k	proportionality factor
P	thrust load, N
S	DN value $\times 10^{-5}$

Equation (1) was calibrated by us at $2.3 \times 10^6 DN$ (65 000 rpm) and a flow rate (V) of 0.038 ℓ/min with the 35-mm-bore-angular-contact ball bearings reported herein whereby $k = 9.16 \times 10^{-32}$. A resultant minimum oil-flow rate at of 17.4×10^{-18} ℓ/min at 1 million DN is predicted using Eq. (1). This predicted oil-flow rate is significantly lower than the rate we used and experimentally determined by Schuller and Anderson (5,6) under comparable conditions. The relation in the brackets relating load, P , and speed, S , appears to us to be specific to the data of Schuller and Anderson (5) and does not appear to be universally applicable for predicting minimum oil flow with air-oil mist lubrication.

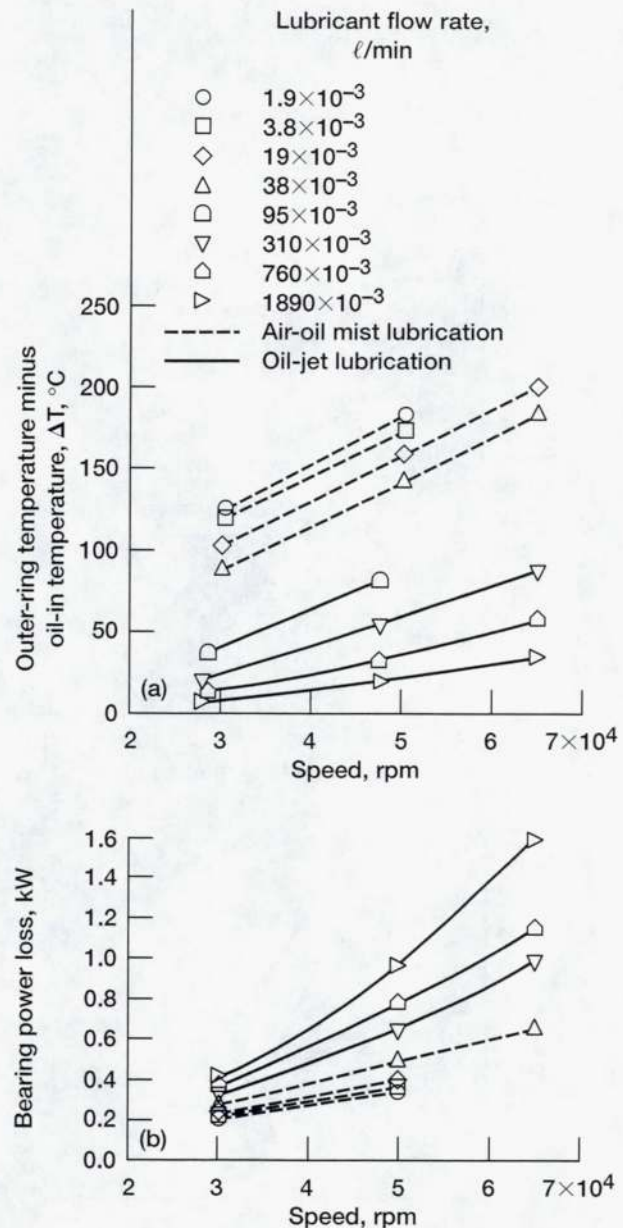

Figure 6.—Effect of bearing speed on bearing temperature and power loss for 35-mm bore angular-contact ball bearing lubricated by air-oil mist and oil jet. Thrust load, 667 N (150 lbf); nominal contact, 24°; cage, single outer-land guided; oil-in temperature, 49 °C (120 °F) for air-oil mist, 121 °C (250 °F) for oil jet. (a) difference between outer-ring temperature and oil-in temperature. (b) Bearing power loss.

Effect on Cage Speed

The cage (separator) epicyclic speed ratio for the angular-contact ball bearings changes with speed, load, and temperature. The difference between the cage epicyclic speed and the measured cage speed is indicative of ball slip as follows:

$$\text{Percent Cage Slip} = [1 - (\text{Measured Cage Speed} \div \text{Calculated Epicyclic Cage Speed})] \times 100 \quad (2)$$

Cage slip is a function of the traction in the ball-race contact and the resistance to rolling within the bearing. Experience has shown that both ball and roller bearings can tolerate reasonable amounts of rolling element to raceway slip provided that a sufficient EHD film is maintained in the ball-race contact. However, under marginal lubrication conditions, such slip can result in bearing damage and failure.

For the bearing used in this study, under a thrust load of 667 N (150 lbs) and speeds of 30 000, 50 000, and 65 000 rpm, the epicyclic cage speeds were calculated to be 13 600, 24 000, and 33 100 rpm, respectively. Based upon measured cage speed, the percentage of cage slip was calculated and plotted as a function of bearing speed for air-oil mist lubrication and oil-jet lubrication in Fig. 7. Cage slip increased with increases in speed. Values of cage slip as high as 7 percent were measured. There was no damage to the bearing surfaces as the result of cage slip. Contrary to what we expected, cage slip was generally higher with air-oil mist lubrication than with oil-jet lubrication.

Effect on Bearing Fatigue Life

We calculated the fatigue life as a function of speed based on measured ring temperature with oil-jet lubrication and under-ring lubrication for the 35-mm-bore-angular-contact ball bearing used in this study. We reported and discussed the results in Pinel et al. (12). As is commonly expected, life decreased both in total revolutions to failure and in absolute hours as a function of speed.

Shamim and Kettleborough (4,8) reported on endurance tests with air-oil mist lubrication and industrial sump lubrication systems. They reported that the air-oil mist lubricated bearings ran approximately 10 °C (18 °F) cooler than those with sump lubrication and with a 25-percent reduction in power loss. They ran endurance tests with 60-mm-bore-angular-contact ball bearings at 2400 rpm (144 000 DN) and a thrust load of 18 900 N (4250 lbs) using an air-oil mist lubrication system and a synthetic ISO Grade 68 oil. They compared their results with those calculated for the same bearing using an oil sump lubrication system with a mineral oil base lubricant. They concluded that longer life is obtained with air-oil mist

lubrication with the synthetic lubricant than with the same bearings operated with the mineral oil and a sump lubrication system.

For a given bearing load and speed, the bearing life is affected by the internal diametral clearance at operating temperature and the EHD film thickness. The method of lubrication used can and apparently does affect these parameters. Thus, while the Shamim and Kettleborough (4,8) conclusion is correct for their experimental conditions and assumptions made for their calculations, it may not always be correct for other bearing operating conditions.

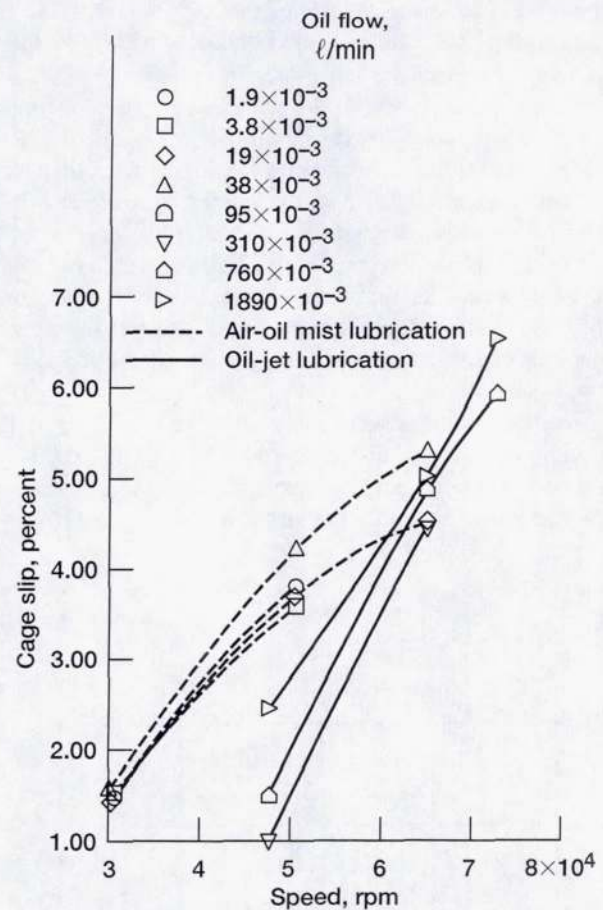

Figure 7.—Effect of lubrication means and speed on cage slip for 35-mm bore, angular-contact ball bearing lubricated by air-oil mist and oil jet. Thrust load, 667 N (150 lbf); nominal contact angle, 24°; cage, single outer-land guided; oil-in temperature, 49 °C (120 °F) for air-oil mist, 121 °C (250 °F) for oil jet.

Based upon oil-in temperature and lubricant flow rate, bearing temperature can to some reasonable degree of engineering certainty be controlled. Bearing life will be a function of the resulting bearing temperature and the difference in temperature between the inner and outer rings. We calculated bearing lives at three speeds, 30 000, 50 000, and 65 000 rpm and four hypothetical temperature combinations. These inner-ring and outer-ring temperature combinations were 154 and 143 °C (310 and 290 °F); 149 and 149 °C (300 and 300 °F); 143 and 154 °C (290 and 310 °F) and 138 and 138 °C (280 and 280 °F). The hotter inner-ring temperature represents what might be obtained with air-oil mist lubrication while the hotter outer-ring temperature is more representative of our results with oil-jet lubrication. The assumption of both rings being of equal temperature can occur with both methods of lubrication. The lower ring temperature of 138 °C (280 °F) represents the lower temperatures obtainable with either lubrication method under the same operating conditions.

The results of the bearing life analysis are summarized in Table 3. Based upon a lower operating temperature of 138 °C (280 °F) at 30 000 rpm, the bearing would theoretically have a 56 percent increase in life over the bearing operated at 149 °C (300 °F). As speed is increased, the life differences decrease. At 65 000 rpm, the difference in life is 9 percent. It can be reasonably concluded that because gross bearing temperatures with air-oil mist lubrication are generally higher than that with oil-jet lubrication, a lower bearing life may occur for a given operating condition.

Where the bearings were assumed to be nominally at the same temperature, the oil-jet lubricated bearing at 30 000 rpm having a lower inner-ring temperature, can have a theoretical life 47 percent greater than the air-oil mist lubricated bearing.

TABLE 3.—THEORETICAL EFFECT OF BEARING COMPONENT TEMPERATURE ON LIFE OF 35-mm BORE ANGULAR-CONTACT BALL BEARING. THRUST LOAD, 667 N (150 lbf); NOMINAL CONTACT ANGLE, 24°; CAGE, SINGLE OUTER-LAND GUIDED

Inner-ring speed, rpm	Assumed ring temperature °C (°F)		Bearing life, hrs ^a
	Inner ring	Outer ring	
30 000	138 (280)	138 (280)	2049
	149 (300)	149 (300)	1315
	143 (290)	154 (310)	1576
	154 (310)	143 (290)	1072
50 000	138 (280)	138 (280)	899
	149 (300)	149 (300)	735
	143 (290)	154 (310)	721
	154 (310)	143 (290)	703
65 000	138 (280)	138 (280)	274
	149 (300)	149 (300)	251
	143 (290)	154 (310)	249
	154 (310)	143 (290)	246

^aLife factor for effect of elastohydrodynamic film thickness included. No other life factors included.

At 50 000 and 60 000 rpm, the life differences are insignificant. From this analysis and the measured temperatures, it may be assumed that where higher bearing temperatures occur with air-oil mist lubrication, lower bearing life will result.

GENERAL COMMENTS

According to Bloch and Shamim (4), air-oil mist lubrication systems have been in use since the 1930's. They describe the state-of-the-art of air-oil mist lubrication systems and discuss their applications. The economics for using air-oil mist is compelling based upon acquisition and operating costs as well as simplicity of design. However, the operating speeds for which they reported rolling-element bearing operating data were relatively low, around 200 000 *DN*. The air-oil mist lubrication bearing data reported by Schuller and Anderson (5) was up to 1.2×10^6 *DN*. The work reported by Rosenlieb (9,10) extended rolling-element bearing operating speed with air-oil mist lubrication to 2.5×10^6 *DN*.

The data reported herein for both air-oil mist lubrication and oil-jet lubrication were for bearing operation where the bearing temperature and power loss were caused from frictional heat generation internal to the bearing. It cannot be assumed a priori that a specific lubrication system will result in lower or higher bearing temperatures, power loss, and higher or lower lives than other lubrication systems. The total thermal environment of the bearing must be considered. As an example, if there is an external heat source such as a hot section of a turbine engine, an air-oil mist lubrication system may not have sufficient heat transfer capacity to maintain the required operating temperature for the bearing. A thermal and heat transfer analysis as well as a bearing fit-up study needs to be undertaken before a commitment is made to a specific lubrication system.

Another issue that must be considered is the EHD film thickness in the ball-race contact. If the calculated lives of Table 3 were extrapolated to 10 000 rpm without further calculation of film thickness, it would be concluded that the life of the bearing would be 3100 hr air-oil mist lubrication and 1500 hr oil-jet lubrication. However, at 10 000 rpm and temperatures of 138 and 149 °C (280 and 300 °F), the EHD film thickness is sufficiently low wherein the bearing operates in the boundary lubrication regime. Accordingly, the calculated bearing lives for both lubrication systems are the same, 1493 hr. The effects of lubricant additives, which are known to affect bearing life, were not addressed in this program.

For high-speed turbomachinery applications an issue of stray (oil) mist must be addressed. As described by Bloch and Shamim (4), as oil mist passes through the bearing, larger oil particles are deposited on the bearing surfaces. However, smaller particles of oil go out with the air. These smaller particles are called stray mist. Bloch and Shamim (4) report that 40 to 60 percent of the oil may go out as stray mist.

They discuss closed loop air-oil mist lubrication systems that can capture or recycle stray mist. The ability to capture or recycle spray mist may be a condition precedent to the application of air-oil mist lubrication systems to high-speed turbomachinery. An alternate approach for air-breathing turbine engines is to burn the stray oil mist with the fuel.

SUMMARY OF RESULTS

Parametric tests were conducted with an optimized 35-mm-bore-angular-contact ball bearing on a high-speed, high-temperature bearing tester. The test bearing has a single-outer-ring, land-guided cage with a nominal 24° contact angle. Both air-oil mist lubrication and oil-jet lubrication systems were used and compared to speeds of 2.5×10^6 DN. The oil-in temperatures were 49 °C (120 °F) and 121 °C (250 °F), for air-oil mist and oil-jet lubrication, respectively. The lubricant was a neopentylpolyol (tetra) ester that met the MIL-L-23699 specification. The following results were obtained:

1. Where the bearing temperature rise is solely caused from heat internally generated from within the bearing cavity, the maximum obtainable speed with air-oil mist lubrication is 2.5×10^6 DN.
2. Lower bearing temperatures and higher power losses are obtained with oil-jet lubrication than with air-oil mist lubrication.
3. Bearing power loss is a direct function of oil flow to the bearing and independent of delivery system. For a given oil-flow rate, bearing temperature and power loss increase with increases in speed.
4. Bearing life is an inverse function of temperature, the difference in temperature between the individual bearing ring components, and the resultant elastohydrodynamic (EHD) film thicknesses. Bearing life is independent of the oil delivery system except as it affects these temperatures.
5. Cage slip increased with increases in speed. Cage slip as high as 7 percent was measured and was generally higher with air-oil mist lubrication than with oil-jet lubrication.

REFERENCES

1. Zaretsky, E.V., "Rolling Bearing and Gear Lubrication," *Tribology for Aerospace Applications*, E. V. Zaretsky, ed., STLE SP-37, Society of Tribologists and Lubrication Engineers, Park Ridge, IL, pp. 207-323, (1997).
2. Zaretsky, E.V., Signer, H., and Bamberger, E.N., "Operating Characteristics of 120 mm Bore Ball Bearings at 3×10^6 DN," NASA TN D-7837, (1974).
3. Signer, H., Bamberger, E.N., and Zaretsky, E.V., "Parametric Study of the Lubrication of Thrust Loaded 120 mm Bore Ball Bearings to 3 Million DN," *ASME Jour. Lubr. Tech.*, 96, 3, pp. 515-525, (1974).
4. Bloch, H.P., and Shamim, A., *Oil Mist Lubrication: Practical Applications*, Prentice Hall, (1998).
5. Schuller, F.T., and Anderson, W.J., "Operating Characteristics of 75-Millimeter Bore Ball Bearings at Minimum Oil Flow Rates Over a Temperature Range to 500 °F," *STLE Lubr. Engr.*, 17, 4, pp. 291-298, (1961).
6. Anderson, W.J., "Extreme-Temperature Bearings," *Advanced Bearing Technology*, E.E. Bisson and W.J. Anderson, eds., National Aeronautics and Space Administration, Washington, DC, NASA SP-38, pp. 309-370, (1964).
7. Morrison, F.R., Zielinski, J., and James, R., "Effects of Synthetic Industrial Fluids on Ball Bearing Performance," *ASME Jour. Energy Source Tech.*, 104, 1, pp. 174-181, (1982).
8. Shamim, A., and Kettleborough, C.F., "Tribological Performance Evaluation of Oil Mist Lubrication," *ASME Jour. Energy Source Tech.*, 116, 1, pp. 224-231, (1994).
9. Rosenlieb, J.W., "Microfog Lubrication for Aircraft Engine Bearings," SKF-AL75TO32 (NASA CR-134977), SKF Industries, Inc., King of Prussia, PA, (1976).
10. Rosenlieb, J.W., "Emergency and Microfog Lubrication and Cooling of Bearings for Army Helicopters," SKF-AL77TO21 (NASA CR-135195), SKF Industries, Inc., King of Prussia, PA, (1978).
11. Jeng, Y.R., and Huang, P.Y., "Temperature Rise of Hybrid Ceramic and Steel Ball Bearings with Oil-Mist Lubrication," *STLE Lubr. Engr.*, 56, 12, pp. 18-23, (2000).
12. Pinel, S.I., Signer, H.R., and Zaretsky, E.V., "Design and Operating Characteristics of High-Speed, Small-Bore, Angular-Contact Ball Bearings," *STLE Trib. Trans.*, 41, 4, pp. 423-434, (1998).
13. Pinel, S.I., and Signer, H.R., "Development of a High-Speed, Small Bore Bearing Test Machine," NASA CR-135083, (1976).

REPORT DOCUMENTATION PAGE

Form Approved
OMB No. 0704-0188

Public reporting burden for this collection of information is estimated to average 1 hour per response, including the time for reviewing instructions, searching existing data sources, gathering and maintaining the data needed, and completing and reviewing the collection of information. Send comments regarding this burden estimate or any other aspect of this collection of information, including suggestions for reducing this burden, to Washington Headquarters Services, Directorate for Information Operations and Reports, 1215 Jefferson Davis Highway, Suite 1204, Arlington, VA 22202-4302, and to the Office of Management and Budget, Paperwork Reduction Project (0704-0188), Washington, DC 20503.

1. AGENCY USE ONLY (Leave blank)	2. REPORT DATE August 2001	3. REPORT TYPE AND DATES COVERED Technical Memorandum	
4. TITLE AND SUBTITLE Comparison Between Oil-Mist and Oil-Jet Lubrication of High-Speed, Small-Bore, Angular-Contact Ball Bearings		5. FUNDING NUMBERS WU-253-02-98-00	
6. AUTHOR(S) Stanley I. Pinel, Hans R. Signer, and Erwin V. Zaretsky		8. PERFORMING ORGANIZATION REPORT NUMBER E-12458	
7. PERFORMING ORGANIZATION NAME(S) AND ADDRESS(ES) National Aeronautics and Space Administration John H. Glenn Research Center at Lewis Field Cleveland, Ohio 44135-3191		10. SPONSORING/MONITORING AGENCY REPORT NUMBER NASA TM-2001-210462	
9. SPONSORING/MONITORING AGENCY NAME(S) AND ADDRESS(ES) National Aeronautics and Space Administration Washington, DC 20546-0001		11. SUPPLEMENTARY NOTES Prepared for the 56th Annual Meeting sponsored by The Society of Tribologists and Lubrication Engineers, Orlando, Florida, May 20-24, 2001. Stanley I. Pinel, Pinel Engineering, Fullerton, California; Hans R. Signer, Signer Technical Services, Fullerton, California; Erwin V. Zaretsky, NASA Glenn Research Center. Responsible person, Erwin V. Zaretsky, organization code 5900, 216-433-3241	
12a. DISTRIBUTION/AVAILABILITY STATEMENT Unclassified - Unlimited Subject Category: 37 Available electronically at http://gltrs.grc.nasa.gov/GLTRS This publication is available from the NASA Center for AeroSpace Information, 301-621-0390.		12b. DISTRIBUTION CODE	
13. ABSTRACT (Maximum 200 words) Parametric tests were conducted with an optimized 35-mm-bore-angular-contact ball bearing on a high-speed, high-temperature bearing tester. Results from both air-oil mist lubrication and oil-jet lubrication systems used to lubricate the bearing were compared to speeds of 2.5×10^6 DN. The maximum obtainable speed with air-oil mist lubrication is 2.5×10^6 DN. Lower bearing temperatures and higher power losses are obtained with oil-jet lubrication than with air-oil mist lubrication. Bearing power loss is a direct function of oil flow to the bearing and independent of oil delivery system. For a given oil-flow rate, bearing temperature and power loss increase with increases in speed. Bearing life is an inverse function of temperature, the difference in temperature between the individual bearing ring components, and the resultant elastohydrodynamic (EHD) film thicknesses. Bearing life is independent of the oil delivery system except as it affects temperature. Cage slip increased with increases in speed. Cage slip as high as 7 percent was measured and was generally higher with air-oil mist lubrication than with oil-jet lubrication.			
14. SUBJECT TERMS Rolling-element bearings; Ball bearings; Life prediction; Lubrication; Oil-jet lubrication; Air-oil mist lubrication		15. NUMBER OF PAGES 17	
17. SECURITY CLASSIFICATION OF REPORT Unclassified		16. PRICE CODE	
18. SECURITY CLASSIFICATION OF THIS PAGE Unclassified	19. SECURITY CLASSIFICATION OF ABSTRACT Unclassified	20. LIMITATION OF ABSTRACT	