

Complex Behavior in Switching Power Converters

CHI K. TSE, SENIOR MEMBER, IEEE, AND MARIO DI BERNARDO, MEMBER, IEEE

Invited Paper

Power electronics circuits are rich in nonlinear dynamics. Their operation is characterized by cyclic switching of circuit topologies, which gives rise to a variety of nonlinear behavior. This paper provides an overview of the chaotic dynamics and bifurcation scenarios observed in power converter circuits, emphasizing the salient features of the circuit operation and the modeling strategies. In particular, this paper surveys the key publications in this field, reviews the main modeling approaches, and discusses the salient bifurcation behaviors of power converters with particular emphasis on the disruption of standard bifurcation patterns by border collisions.

Keywords—Bifurcation, chaos, dc–dc converters, nonlinear dynamics, power electronics, switching power converters.

I. INTRODUCTION

Power electronics is a discipline spawned by real-life applications in industrial, commercial, residential, and aerospace environments. Much of its development evolves around some immediate needs for solving specific power conversion problems. In the past three decades, this branch of electrical and electronic engineering has undergone an intense development in many aspects of technology [1], including power devices, control methods, circuit design, computer-aided analysis, passive components, packaging techniques, etc. The principal focus in power electronics, as reflected from topics discussed in some key conferences [2], [3], is to fulfill the functional requirements of the application for which its circuits are used. Like many areas of engineering, power electronics is mainly motivated by practical applications and it often turns out that a particular circuit topology or system implementation has found widespread applications long before it has been thoroughly

Manuscript received June 15, 2001, revised November 26, 2001. This work was supported in part by the Research Grants Council, Hong Kong, under Grant PolyU 5131/99E.

C. K. Tse is with the Department of Electronic and Information Engineering, The Hong Kong Polytechnic University, Hung Hom, Kowloon, Hong Kong, China (e-mail: encktse@polyu.edu.hk).

M. di Bernardo is with the Department of Engineering, University of Sannio, I-82100 Benevento, Italy (e-mail: dibernardo@unisannio.it).

Publisher Item Identifier S 0018-9219(02)05253-2.

analyzed. For instance, the widespread application of a simple switching converter may date back to more than three decades ago. However, good analytical models allowing better understanding and systematic circuit design were only developed in the late 1970s [4] and in-depth analytical characterization and modeling is still being actively pursued today. Despite their common occurrence in power electronics circuits, nonlinear phenomena have only recently received appropriate formal treatments.

In this paper, we review some of the nonlinear phenomena observed in typical power electronics systems. Our intention is to provide an overview of the recent research effort in the study of nonlinear phenomena in power converters, and to summarize the essential analytical approaches that can be used to perform a systematic study of the nonlinear behavior of such systems. The rest of the paper is outlined as follows. We begin in Section II with a brief overview of power electronics circuits, followed by a discussion of the benefits of studying chaotic dynamics in power electronics in Section II-C. A quick tour of some recent findings is presented in Section III. In Section IV, we present a discussion of the modeling methods for characterizing nonlinear behavior such as bifurcation and chaos in switching converter circuits. In Section V, we focus on the typical bifurcation scenarios observed in switching power converters, expounding their most relevant aspects from a practical viewpoint.

II. BRIEF OVERVIEW OF SWITCHING CONVERTERS OPERATION

The basic operation of any power electronics circuit involves toggling among a set of linear or nonlinear circuit topologies, under the control of a feedback system. As such, they can be regarded as *switched* or *piecewise-smooth* dynamical systems.

For example, in simple direct current–direct current (dc–dc) converters, such as the ones shown in Fig. 1, an inductor is “switched” between the input and the output through an appropriate switching element (labeled as S

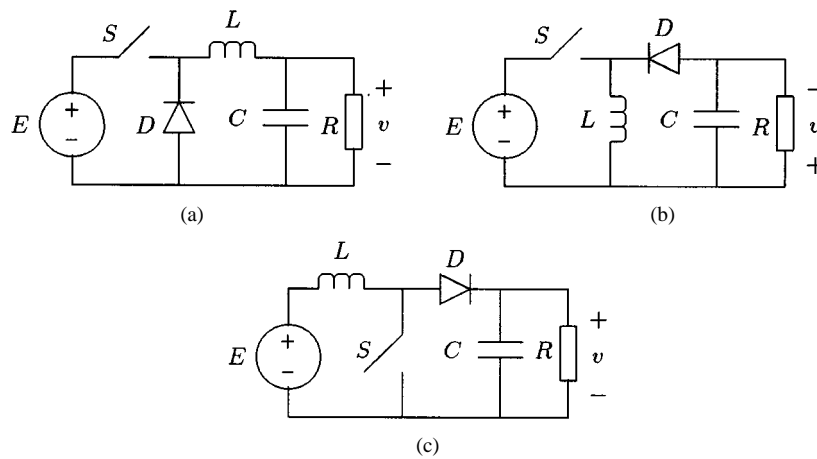

Fig. 1. Simple dc-dc converters. (a) Buck converter. (b) Buck-boost converter. (c) Boost converter.

in the figure). The way in which the inductor is switched determines the output voltage level and transient behavior. Usually, a semiconductor switch and a diode are used to implement such switching and through the use of a feedback control circuit, the relative durations of the various switching intervals are continuously adjusted. Such feedback action effectively controls the transient and steady-state behaviors of the circuit. Thus, both the circuit topology and the control method used determine the dynamical behavior of a power electronics circuit.

A. Simple DC-DC Converter Circuits

Many power converters are designed on the basis of the three simple converters shown in Fig. 1. In a typical period-1 operation,¹ the switch and the diode are turned on and off in a cyclic and complementary manner, under the command of a pulse-width modulator. When the switch is closed (the diode is open), the inductor current ramps up. When the switch is open (the diode closed), the inductor current ramps down. The duty ratio, defined as the fraction of a repetition period T during which the switch is closed, is continuously controlled by a feedback circuit that aims to maintain the output voltage at a fixed level even under input and load variations. Two typical feedback arrangements are shown in the next subsection.

As we will see later in this paper, although the period-1 stable operation is the preferred operation for most industrial applications, it represents only one particular operating regime. Because of the existence of many possible operating regimes, it would be of practical importance to have a thorough understanding of what determines the behavior of the circuit so as to guarantee a desired operation or to avoid an undesirable one.

B. Typical Control Strategies

Most dc-dc converters are designed to deliver a regulated output voltage. The control of dc-dc converters usually takes on two approaches, namely, voltage feedback

¹In dc-dc converters, period-1 operation refers to an operating regime where all waveforms repeat at the same rate as the driving clock. Thus, period- n operation refers to the case where the periods of all waveforms are exactly n times that of the driving clock.

control and current-programmed control, also known as *voltage-mode* and *current-mode* control, respectively [6]. In voltage-mode control, the output voltage is compared with a reference signal to generate a control signal which drives the pulse-width modulator via some typical feedback compensation configuration. For current-mode control, an inner current loop is used in addition to the voltage feedback loop. The aim of this inner loop is to force the inductor current to follow some reference signal provided by the output voltage feedback loop. The result of current-mode control is a faster response. This kind of control is mainly applied to boost and buck-boost converters, which suffer from an undesirable nonminimum phase response [5], [6]. The simplified schematics are shown in Fig. 2.

C. Studying Chaos in Switching Power Converters

Power electronics engineers have to deal frequently with unexpected phenomena such as subharmonic oscillations, jumps, quasi-periodic operating regimes, sudden broadening of power spectra, bifurcations, and chaos. Despite their frequent occurrence, nonlinear phenomena and the underlying causes are not always thoroughly understood by engineers [7], [8]. For instance, most power supply engineers would have experienced bifurcation phenomena and chaos in their circuits when some parameters (e.g., input voltage and feedback gain) are varied, but usually do not examine the phenomena in detail. The usual reaction of the engineers is to avoid these phenomena by adjusting component values and parameters, often through some trial-and-error procedure. Thus, these phenomena remain somewhat mysterious and rarely examined in a formal manner.

The barrier to the study of nonlinear behavior in power electronics lies mainly in the engineers' attitude to this kind of study rather than technical competence. As will be discussed in Section IV, one of the most favorite techniques in engineering has been *linearization*. This has the obvious advantage of making the analysis easier through the familiar frequency-domain small-signal techniques. Indeed, if linearized models can be profitably used in design (and as long as the restricted validity of the models does not adversely compromise the design integrity), there seems to be no

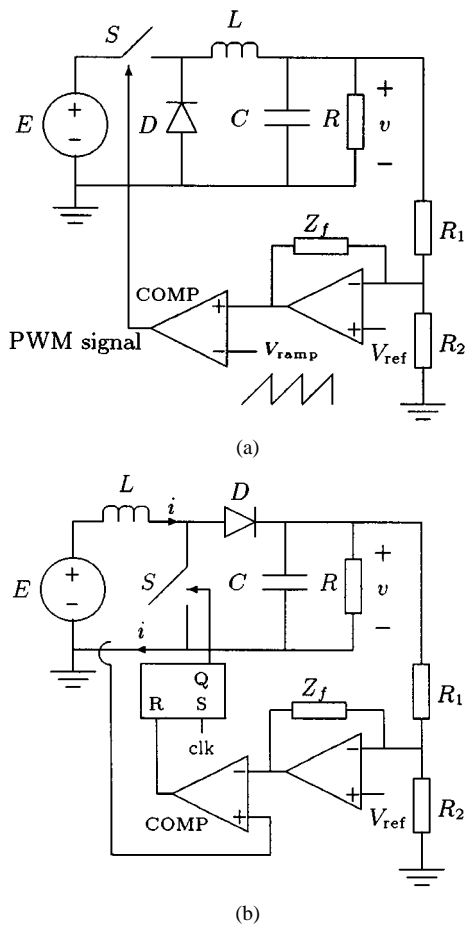

Fig. 2. Typical control approaches for dc-dc converters. (a) Voltage-mode control. (b) Current-mode control.

immediate need for investigating nonlinear phenomena such as chaos and bifurcation. However, as the field of power electronics gains maturity and as the demand for better functionality, reliability and performance of power electronics systems increases, in-depth analysis of complex behavior and nonlinear phenomena becomes justifiable and even mandatory. On the one hand, the study of nonlinear phenomena offers the opportunity of rationalizing the commonly observed behavior. Thus, knowing how and when chaos occurs, for instance, will certainly help to avoid it, if “avoiding it” is what the engineers want. On the other hand, many previously unused nonlinear operating regimes may be profitably exploited for useful engineering applications, provided that such operations are thoroughly understood. For these reasons, the study of bifurcations and chaos in power electronics has recently attracted much attention from both the power electronics and the circuits and systems communities.

In Section III, we present a chronological survey of some of the most relevant recent findings in the identification, analysis, and modeling of nonlinear phenomena in power electronics circuits and systems.

III. SURVEY OF RESEARCH FINDINGS

The occurrence of bifurcations and chaos in power electronics was first reported in the literature in the late 1980s

[9]–[11]. Experimental observations regarding boundedness, chattering and chaos were also made by Krein and Bass [12] in 1990. Although these early reports did not contain any rigorous analysis, they seriously pointed out the importance of studying the complex behavior of power electronics and its possible benefits for practical design. Since then, much interest has been directed toward pursuing formal studies of the complex phenomena commonly observed in power electronics.

In 1990, Hamill *et al.* [13] reported a first attempt to study chaos in a simple buck converter at the IEEE Power Electronics Specialists Conference. Their work became subject of further investigations in the following years and stimulated much of the ongoing research effort into the nonlinear behavior of power converters. Using an implicit iterative map, the occurrence of period doublings, subharmonics, and chaos in a simple buck converter was demonstrated by numerical analysis, PSPICE simulation, and laboratory measurements. The derivation of a closed-form iterative map for the boost converter under a current-mode control scheme was presented later by the same group of researchers [14]. This closed-form iterative map allowed the analysis and classification of bifurcations and structural instabilities of this simple converter. Since then, a number of authors have contributed to the identification of bifurcation patterns and strange attractors in a wide class of circuits and devices of relevance to power electronics. Some key publications are summarized below. Alternative reviews are found in [15]–[17]. Most recently, an edited book, which is devoted entirely to the subject of nonlinear phenomena in power electronics, has also been published [18].

The occurrence of period-doubling cascades for a simple dc-dc converter operating in discontinuous mode was reported in 1994 by Tse [19], [20]. By modeling the dc-dc converter as a first-order iterative map, the onset of period-doubling bifurcations can be located analytically. The idea is based on evaluating the Jacobian of the iterative map about the fixed point corresponding to the solution undergoing the period doubling and determining the condition for which a period-doubling bifurcation occurs. Simulations and laboratory measurements have confirmed the findings. Formal theoretical studies of conditions for the occurrence of period-doubling cascades in discontinuous-mode dc-dc converter were reported subsequently by Chan and Tse [21]. Further work on the bifurcation behavior of the buck converter was reported by Chakrabarty *et al.* [22], who specifically studied the bifurcation behavior under variation of a range of circuit parameters including storage inductance, load resistance, output capacitance, etc. In 1996, Fossas and Olivar [23] presented a detailed analytical description of the buck converter dynamics, identifying the topology of its chaotic attractor and studying the regions associated with different system evolutions. Various possible types of operation of a simple voltage-feedback pulse-width-modulated buck converter were also investigated through the so-called stroboscopic map obtained by periodically sampling the system states. This method will be discussed later in this paper.

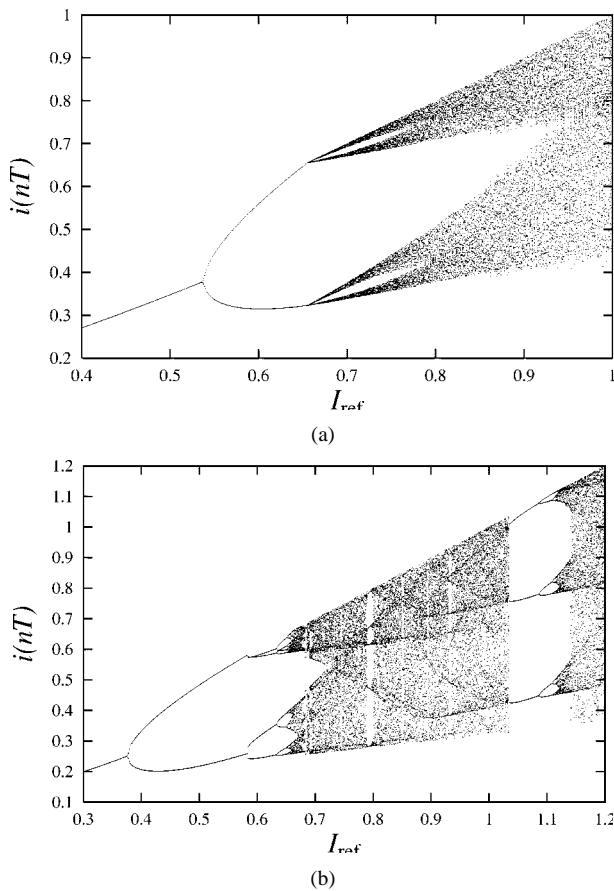

Fig. 3. Bifurcation diagrams from a current-mode controlled boost converter with $L = 1.5$ mH, $R = 40$ Ω and $T = 100$ μ s. I_{ref} denotes the reference peak inductor current, i.e., the inductor current value at the turn-off instant of the switch. For (a), $T/CR = 0.125$ (large C), and for (b), $T/CR = 0.625$ (small C).

The bifurcation behavior of dc–dc converters under current-mode control has been studied by a number of authors. Deane [24] first discussed the route to chaos in a current-mode controlled boost converter. Chan and Tse [25] studied various types of routes to chaos and their dependence upon the choice of bifurcation parameters. Fig. 3 shows two bifurcation diagrams numerically obtained from a current-mode controlled boost converter, with inductor current level being the bifurcation parameter. Fig. 4 shows a series of trajectories as the current level increases. In 1995, the study of bifurcation phenomena was extended to a fourth-order \dot{C} uk dc–dc converter under a current-mode control scheme [26]. The four-dimensional system is represented by an implicit fourth-order iterative map, from which routes to chaos are identified numerically.

As can be seen from Fig. 3(a) for the case of the boost converter, the bifurcation behavior contains transitions where a “sudden jump from periodic solutions to chaos” is observed. These transitions cannot be explained in terms of standard bifurcations such as “period doubling” and “saddle node.” In fact, as proposed by Banerjee *et al.* [27], [28] and Di Bernardo [30], these transitions are due to a class of bifurcations known as “grazings” or “border collisions,” which is unique to switched dynamical systems [31]–[33]. (See Section V for details.)

Since most power electronics circuits are nonautonomous systems driven by fixed-period clock signals, the study of the dynamics can be effectively carried out using appropriate iterative maps. In addition to simple uniform sampling, Di Bernardo *et al.* [34] studied alternative sampling schemes and their applications to the study of bifurcation and chaos in power electronics [30]. It has been found that nonuniform (event-driven) sampling can be used, under certain conditions, to derive iterative maps which can be used to characterize effectively the occurrence of bifurcations and chaos in both autonomous and nonautonomous systems. Also, the occurrence of periodic chattering (high-frequency switchings) or multiple pulsing can be explained in terms of so-called sliding solutions [35].

When external clocks are absent and the system is “free-running,” e.g., under a hysteretic control scheme, the system is autonomous and does not have a fixed switching period. Such free-running converters were indeed extremely common in the old days when fixed-period integrated-circuit controllers were not available. A representative example is the free-running \dot{C} uk converter that has been shown by Tse *et al.* [36] to exhibit Hopf bifurcation and chaos. Another example is the tolerance-band controlled converter that has been shown by Magauer and Banerjee [37] to exhibit merging crisis and saddle-node bifurcations.

Power electronics circuits other than dc–dc converters have also been examined in recent years. Dobson *et al.* [38] reported “switching time bifurcation” of diode and thyristor circuits. Such bifurcation manifests as jumps in the switching times. Bifurcation phenomena from induction motor drives were reported separately by Kuroe [39] and Nagy *et al.* [40]. Finally, some attempts have been made to study higher order parallel-connected systems of converters, which are becoming popular design choice for high-current applications [41], [42].

IV. MODELING STRATEGIES

A. Modeling Alternatives

As mentioned previously, switching converters are essentially piecewise-switched circuits [43]. The number of possible circuit topologies is usually fixed and the switching is done in a cyclic manner (but not necessarily periodically because of the feedback action). This results in a nonlinear time-varying operating mode, which naturally demands the use of nonlinear methods for analysis and design. Indeed, researchers and engineers who work in this field are always dealing with nonlinear problems and have attempted to explore methods not normally used in other circuit design areas, e.g., state-space averaging [4], phase-plane trajectory analysis [44], Lyapunov-based control [45], Volterra series approximation [46], etc. However, in order to expedite the design of power electronics systems, “adequate” simplifying models are imperative. In the process of deriving models, accuracy is often traded off for simplicity for many good practical reasons. Since closed-loop stability and transient responses are basic design concerns in practical power electronics systems, models that can permit the direct application

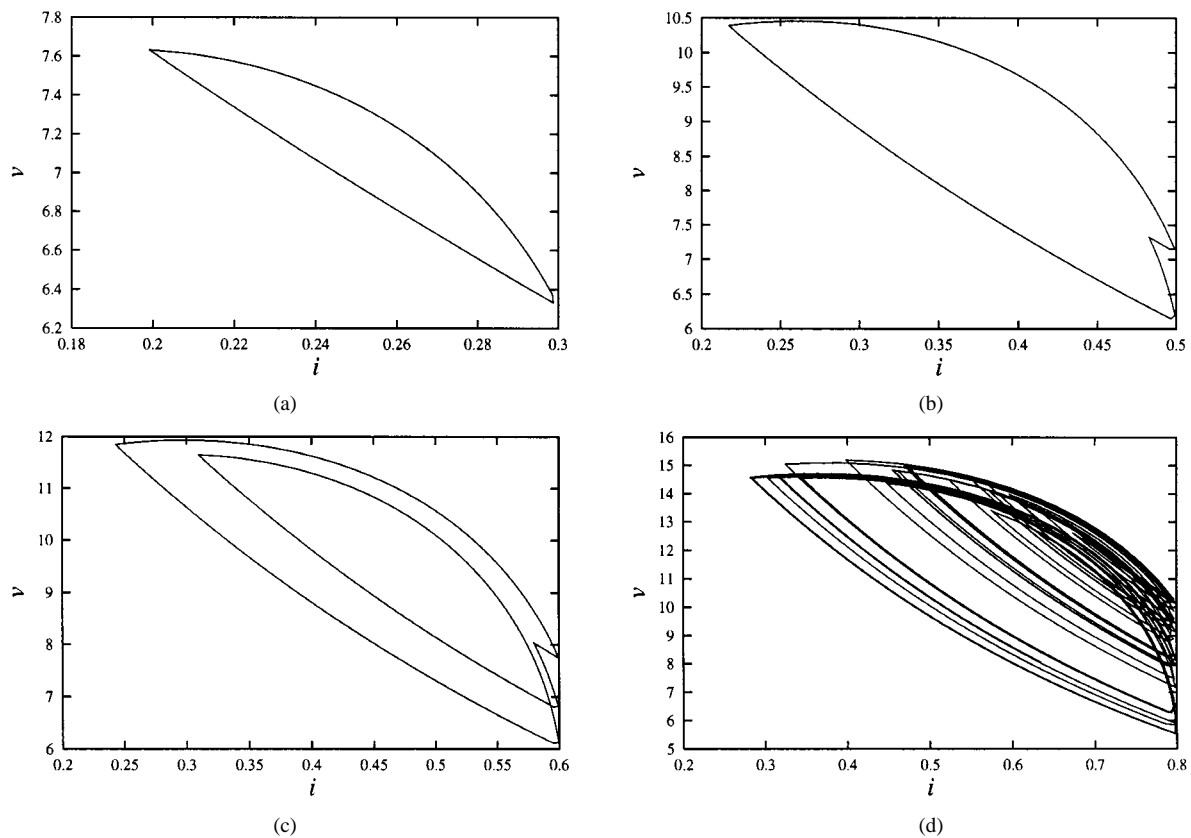

Fig. 4. Trajectories from a current-mode controlled boost converter. v and i are output voltage and inductor current, respectively, consistent with Fig. 2. (a) Stable period-1 operation. (b) Stable period-2 operation. (c) Stable period-4 operation. (d) Chaotic operation.

of conventional frequency-domain approaches will present obvious advantages. Thus, much research in modeling power electronics circuits has been directed toward the derivation of a linear model that is appropriate to a frequency-domain analysis, the limited validity being the price to pay. (The fact that most engineers are trained to use linear methods is also a strong motivation for developing linearized models.) The use of linearized models for analysis is relatively mature in power electronics. However, it falls short of predicting any nonlinear behavior.

Since our purpose here is nonlinear analysis, we will not consider linearization right at the start of the analysis, which effectively suppresses all nonlinear terms. In fact, linearization is a useful technique only when we need to characterize the system behavior locally around a point in the state space. The major modeling step prior to linearization is the derivation of a suitable nonlinear model. We will focus on two particularly useful modeling approaches:

- 1) continuous-time averaging approach;
- 2) discrete-time iterative-map approach.

Before going into details of these approaches, we should emphasize that each of them has its own advantages and disadvantages. Averaging is simple and more likely to give tractable mathematical and circuit models; it is, however, useful only to characterize low-frequency phenomena. On the contrary, the derivation of iterative maps is more complicated but the resulting maps offer more complete information on the dynamical behavior of the system under investigation.

As we will see, each method can be used to study bifurcation behavior of switching converters. The key question is “when to use what.” We will come back to this important issue after we have described the salient features of these modeling alternatives (see Section IV-D).

Because of their suitability to study low- or high-frequency regimes, the aforementioned modeling approaches have been sometimes labeled as slow- and fast-scale approaches, respectively. The observed phenomena may therefore be classified accordingly. Analysis from this viewpoint has recently been reported by Mazumder *et al.* [47].

B. Averaging

The averaging approach [4] is one of the most widely adopted modeling strategies for switching converters. It initially yields simple nonlinear models that contain no time-varying parameters and, hence, can be used more conveniently for analysis and design. Essentially, an averaged model does not take into account the switching details but focuses only on the envelope of the dynamical motion. This is well suited to characterize power electronics circuits in the low-frequency domain.²

²In practice, such so-called “averaged” models are often linearized to yield linear time-invariant models that can be directly studied in a standard Laplace transform domain or frequency domain, facilitating design of control loops and evaluation of transient responses in ways that are familiar to practitioners.

Suppose the switching converter under study toggles between N circuit topologies. In one switching cycle, it spends a fraction of time in one particular topology. Let x be the state vector, d_j be the fraction of the period in which the circuit stays in the j th topology, and T be the period of one switching cycle. Obviously, we have $d_1 + d_2 + \dots + d_N = 1$. Thus, we can write down the following state equations for the first period:

$$\dot{x} = \begin{cases} A_1x + B_1E, & \text{if } 0 \leq t < d_1T \\ A_2x + B_2E, & \text{if } d_1T \leq t < (d_1 + d_2)T \\ \dots & \\ A_Nx + B_NE, & \text{if } (1 - d_N)T \leq t < T \end{cases} \quad (1)$$

where A_j and B_j are the system matrices for the j th topology and E is the input voltage. It should be noted that most practical switching converters involve a relatively small N , typically two or three. The essential step in the modeling is to “average” out the system matrices [4], yielding the following averaged model:

$$\dot{x} = A_mx + B_mE, \quad \text{for all } t \quad (2)$$

where

$$A_m = \sum_{j=1}^N d_j A_j \quad \text{and} \quad B_m = \sum_{j=1}^N d_j B_j. \quad (3)$$

Finally, we need to state the control law which completes the model. This is usually given as a set of equations defining explicitly or implicitly the quantities d_j . The general form of such a set of equations is

$$\begin{cases} G_1(d_1, d_2, \dots, E, x) = 0 \\ G_2(d_1, d_2, \dots, E, x) = 0 \\ \dots \end{cases} \quad (4)$$

Note that the above equations generally define the duty cycles d_j as nonlinear functions of the system states and parameters. Thus, despite its appearance, the averaged model is nonlinear.

In the case of a simple dc–dc converter having two topological states, the control law specifies just one duty cycle, say d_1 , i.e., the fraction of time spent in one of the two possible configurations. The usual pulse-width modulation feedback control method involves comparing a control signal (depending on the state variables) with a ramp signal. The system then switches to a different configuration whenever these two signals intersect. Thus, the control law can be simply stated as

$$V_{\text{ramp}}(d_1T) = v_c(x(d_1T)) \quad (5)$$

where $V_{\text{ramp}}(t)$ is a ramp voltage signal and $v_c(\cdot)$ is a suitable control signal derived from the state variables.

In essence, averaging retains the low-frequency properties while ignoring the detailed dynamics within a switching cycle. Usually, the validity of averaged models is only restricted to the low-frequency range up to an order of magnitude below the switching frequency. For this reason, averaged models become inadequate when the aim is to explore nonlinear phenomena that may appear across a wide

spectrum of frequencies. Nevertheless, averaging techniques can be useful to analyze those bifurcation phenomena which are confined to the low-frequency range. For instance, in a switching converter, an averaged model can be effectively used to study the so-called Hopf bifurcation, which explains the formation of persistent oscillations (limit cycles) consisting of many switching periods (low-frequency orbit) [36], [48].

C. Derivation of Iterative-Maps

An effective approach for modeling power electronics circuits with a higher degree of accuracy is to use appropriate discrete-time maps obtained by uniform or nonuniform sampling of the system states. Essentially, the aim is to derive an iterative function that expresses the state variables at one sampling instant in terms of those at an earlier sampling instant.

To illustrate the idea, we consider maps³ obtained by uniform sampling of the system states at time instants multiple of the period T , i.e., $t = nT$, for $n = 0, 1, 2, \dots$. Referring to (1), we can express the value of the state vector x at the end of the subinterval corresponding to the j th topology in terms of its value at the beginning of that subinterval. For the sake of brevity, let t_j be the time instant at the beginning of the j th subinterval, i.e., the time instant that corresponds to the circuit switching from the $(j - 1)$ th to the j th configuration. Moreover, letting d_j be the duty ratio corresponding to the subinterval beginning at t_j , i.e., $d_j = (t_{j+1} - t_j)/T$, we have

$$x(t_{j+1}) = \Phi_j(d_jT)x(t_j) + \int_0^{d_jT} \Phi_j(\xi)B_jE \, d\xi \quad (6)$$

where Φ_j is the transition matrix corresponding to A_j . Thus, by composing together equations for all subintervals within a switching period, we obtain the required iterative map, which takes the following form:

$$x_{n+1} = \Phi_T(d_1, d_2, \dots)x_n + \Psi_T(d_1, d_2, \dots)E \quad (7)$$

$$= F(x_n, d_n) \quad (8)$$

where x_n denotes the state vector at $t = nT$, d_n denotes the set of duty ratios for the cycle beginning at $t = nT$, and

$$\Phi_T(\cdot) = \Phi_N(d_NT)\Phi_{N-1}(d_{N-1}T) \dots \Phi_1(d_1T) \quad (9)$$

$$\begin{aligned} \Psi_T(\cdot) = & \Phi_N(d_NT)\Phi_{N-1}(d_{N-1}T) \dots \Phi_2(d_2T) \\ & \cdot \int_0^{d_1T} \Phi_1(\xi)B_1 \, d\xi \\ & + \Phi_N(d_NT)\Phi_{N-1}(d_{N-1}T) \dots \Phi_3(d_3T) \\ & \cdot \int_0^{d_2T} \Phi_2(\xi)B_2 \, d\xi + \dots \\ & + \Phi_N(d_NT) \int_0^{d_{N-1}T} \Phi_{N-1}(\xi)B_{N-1} \, d\xi \\ & + \int_0^{d_NT} \Phi_N(\xi)B_N \, d\xi. \end{aligned} \quad (10)$$

³These maps are often termed *stroboscopic maps* to distinguish those obtained by nonuniform sampling or switching maps.

Finally, a control law is needed, as in the averaging case, to complete the model. This can take the form of (4). Alternatively, we can also consider discrete-time control laws of the form $d_j = f_j(x_n)$ at the beginning of each switching cycle, i.e., at $t = nT$.

D. Suitability of the Models

To sum up, we have introduced two types of modeling strategies. The averaged model takes the form of a set of continuous differential equations, whereas the iterative-map model takes a discrete-time form. They are suited for different analytical scenarios, as will become apparent later. Briefly, the averaged model is useful for characterizing the low-frequency behavior of the circuit while the iterative map allows a more complete dynamical description. For instance, averaged models can be used to study the scenario where a regular periodic motion breaks down via a Hopf bifurcation into a limit cycle or a quasi-periodic orbit of a much longer period [36]. On the other hand, period doublings and other bifurcations causing the formation of solutions in the high-frequency range can only be studied through appropriate discrete-time models [19]–[30].

V. ANALYSIS OF BIFURCATIONS IN SWITCHING POWER CONVERTERS

As mentioned earlier in Section III, switching power converters can exhibit several bifurcation phenomena. These include standard bifurcations such as period doublings and Hopf bifurcations, as well as nonstandard ones such as border collisions and grazings which are due to the switching (i.e., nonsmooth) nature of these systems.⁴ These latter phenomena often manifest themselves as discontinuous transitions or “sudden jumps,” for instance, from periodic regimes to chaos. In the literature, the occurrence of these transitions is commonly explained as due to interactions between system trajectories and state-space boundaries where the system switches from one configuration to another (or *switching manifolds*) [54]. For example, a *border collision* is said to occur when, under parameter variations, an equilibrium or fixed point of the system under investigation crosses one of these boundaries [see Fig. 8(b)]. *Grazing bifurcations*, instead, correspond to tangential intersections of a periodic orbit with a switching manifold [see Fig. 8(a)]. Other bifurcations are possible when other solutions, such as quasi-periodic trajectories, interact with the switching manifolds.

Typically, power electronics systems exhibit a combination of standard bifurcations, border collisions, and other nonsmooth bifurcations, as one or more parameters are varied.

⁴In the Russian literature, these bifurcations are known collectively as *C bifurcations*, where *C* is the first letter of the Russian word for “sewing.” Heuristically these bifurcations “sew” together sections of trajectories belonging to different system configurations. For clarity in this paper, we refer mainly to border collisions and grazings as these terms describe better the actual physical meaning when applied to power electronics circuits and systems.

A. Standard Bifurcations and Border Collisions—A Real Phenomenon in Switching Converters

At the time of writing, there is enough analytical and experimental evidence to conclude that switching converters exhibit mainly a combination of the following two types of bifurcations, which can occur under the variation of the same (set of) parameter(s):

- 1) standard bifurcations (e.g., period doubling, Hopf, etc.);
- 2) border collisions and grazings (e.g., period-1 to chaos, period-2 to period-3, etc.).

Namely, a switching converter can exhibit a series of standard bifurcations, e.g., period doubling, Hopf, saddle node, etc., as some parameters are varied. Moreover, because of the switching nature, sudden transitions or “jumps” can occur, for instance, from a periodic orbit to chaos. Two examples are shown in Fig. 3. In the bifurcation diagram of Fig. 3(a), the system exhibits a period doubling once at $I_{\text{ref}} \approx 0.53$, then suddenly jumps (without further period doublings) to chaos at $I_{\text{ref}} \approx 0.65$. Likewise, in Fig. 3(b), the system undergoes a period doubling at $I_{\text{ref}} \approx 0.38$, and abruptly jumps to a period-4 orbit at $I_{\text{ref}} \approx 0.58$. Then, period doubling resumes.

To appreciate the underlying cause of border collisions and how they disrupt standard bifurcation patterns, let us take a simple practical viewpoint and consider a switching converter where the switching instant is determined by the intersection of a ramp signal and a control signal. Essentially, as shown in Fig. 5(a), the switch is turned on or off, according to the ramp signal being larger or smaller, respectively, than the control signal. Therefore, the ramp signal defines an hyperplane in the phase space across which the system changes its configuration.

Now, suppose we increase the feedback gain gradually and examine the steady-state waveforms. The following is what typically happens in a voltage-mode controlled buck converter.

- 1) As the feedback gain increases, the converter exhibits period doubling. Fig. 5(b) and (c) shows the situation before and after a period-doubling bifurcation.
- 2) As the feedback gain increases further, the control signal swings too high and fails to hit the ramp signal within each cycle. A border-collision bifurcation corresponds to the limiting case where the control signal just “grazes” the upper or lower tip of the ramp signal. Its occurrence can give rise to a sudden jump to a chaotic regime thereafter. Fig. 5(d) shows the situation when border collision occurs.

Clearly, as described earlier, we can see that a border collision results from an excessive swing of the control signal, which causes the duty ratio to saturate abruptly to zero or one, thus preventing the standard period-doubling cascade from proceeding further as the parameter continues to vary. Such interplay between standard bifurcations and border collisions is characteristic of many power electronics circuits. In fact, for converters employing different control methods, similar scenarios can be identified. For example, current-mode controlled boost converters have been shown to undergo almost

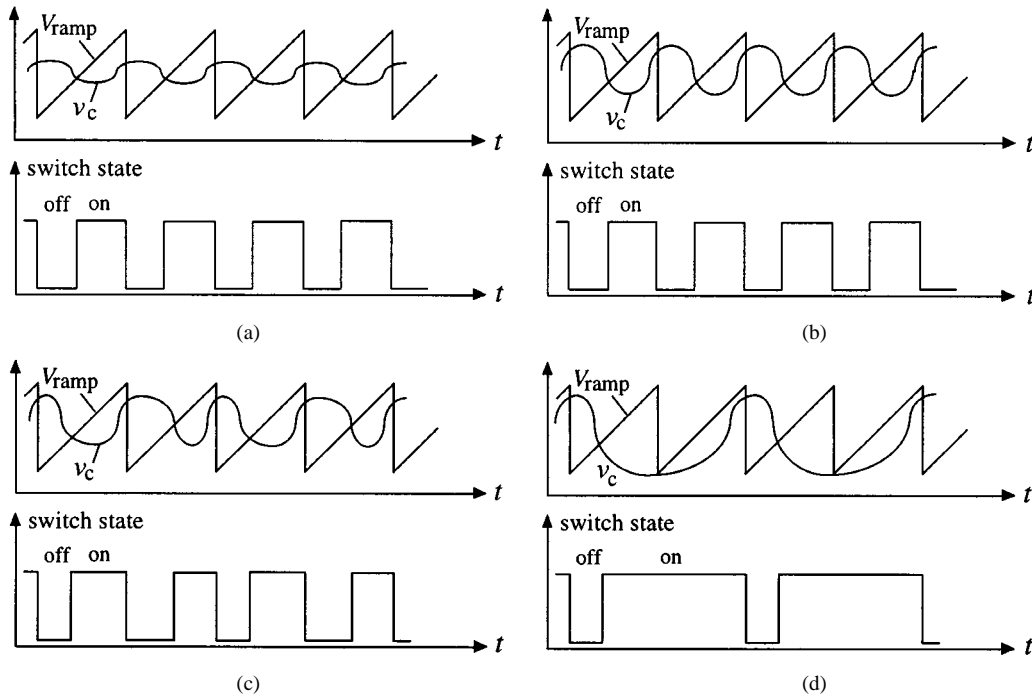

Fig. 5. Period-doubling cascade interrupted by a border collision as the feedback gain increases. (a) Period-1 operation. (b) Period-1 operation (larger feedback gain). (c) Period-2 operation. (d) Border collision (often leading to the onset of chaotic regimes).

always a border collision after a period-doubling bifurcation. The underlying cause for the occurrence of the border collision in this case is similar, i.e., the limited range within which the standard bifurcation cascade can continue to develop (see Fig. 3).

B. Analysis of Standard Bifurcations

The literature already abounds with methods of analysis and classification of standard bifurcations like period doublings and Hopf bifurcations [49]. In what follows, we summarize some typical analytical approaches to study standard bifurcations in switching power converters. Rather than giving a detailed analytical account we outline the main ideas behind their characterization from a practical viewpoint.

Essentially, the analysis begins with the system model. If an averaged model is studied, the set of continuous-time differential equations used to describe the circuit and its control law will be used to analyze the possible bifurcation scenarios. The linearized system $\dot{x} = Ax$ is examined and its eigenvalues λ are found by solving

$$\det |\lambda I - A| = 0 \quad (11)$$

where I is the unit matrix of appropriate size. Generally, standard bifurcations such as period-doubling and Hopf bifurcations are associated with eigenvalues with a zero real part in continuous-time systems and unitary modulus in discrete-time ones. Thus, to locate bifurcations, we are interested in observing how the eigenvalues of the model move on the complex plane (root loci) as a chosen parameter is varied.

For example, when a continuous-time model exhibits a pair of complex conjugate eigenvalues that crosses the imaginary axis for some parameter value at a nonzero rate, then a Hopf bifurcation may occur. Appropriate Poincaré maps can also be used to characterize the stability of the resulting limit cycles [49], [51].

If an iterative map is used to model the system, the linearized system is again examined. Specifically, suppose the iterative map is $x_{n+1} = F(x_n, \mu)$, then the Jacobian J_F characterizing the linearized system is given by $\partial F / \partial x_n$ evaluated at the fixed point. The eigenvalues of J_F can be obtained by solving the characteristic equation

$$\det |\lambda I - J_F| = 0. \quad (12)$$

In this case, the modulus of the eigenvalues needs to be taken into account. For instance, if one of the eigenvalues is observed to move out of the unit circle on the real line, i.e., through the point -1 , then we may establish a period doubling. A host of analytical results and solution approaches can be found in standard texts on nonlinear dynamical systems [50]–[53].

In general, both continuous-time and discrete-time models or maps can be used to study bifurcations. Thus, the important question is again *what is the right model for the analysis*. Clearly, the answer varies from one converter to the other. In power electronics, as in many other practical engineering disciplines, the clue often comes from carrying out suitable computer simulations and/or experimental observations. For instance, when studying a voltage-mode controlled buck converter, one could be tempted at first to use a simple averaged model. However, experiments and simulations would soon

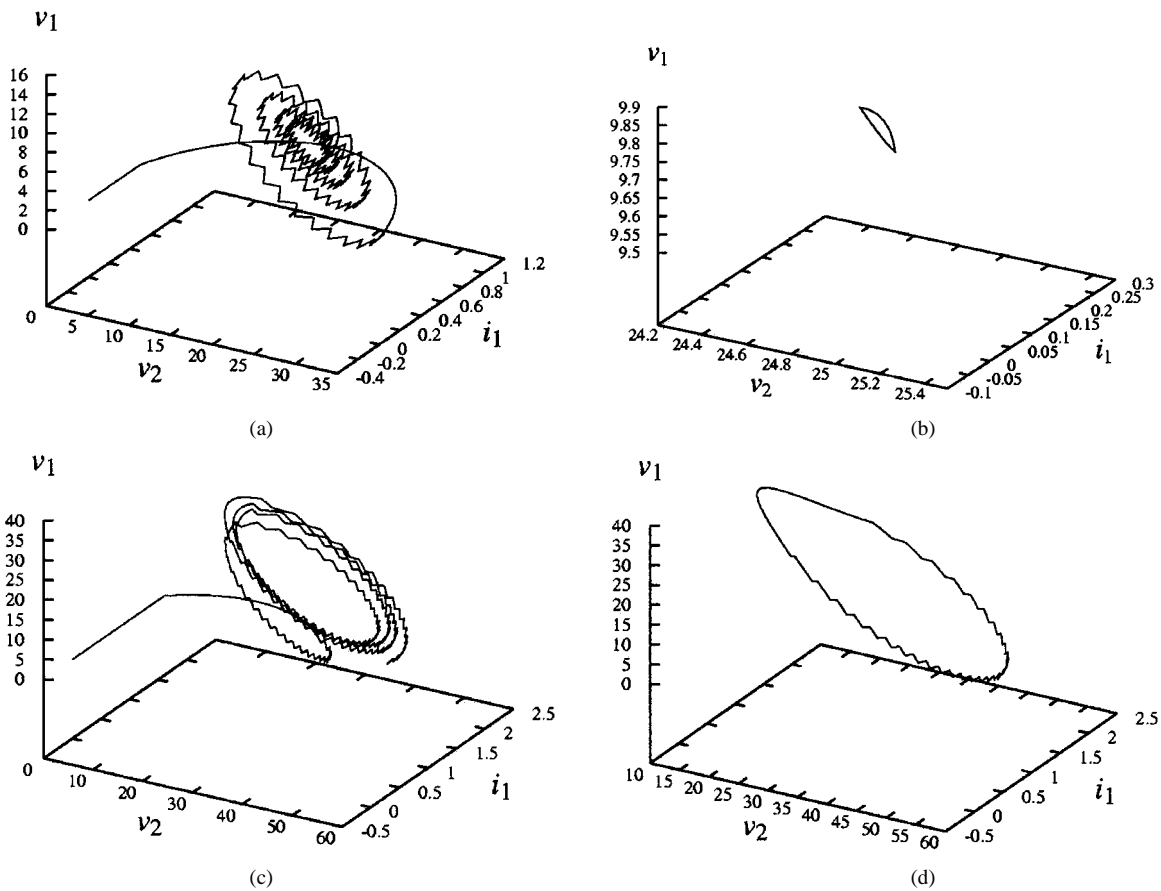

Fig. 6. Hopf bifurcation from a free-running Ćuk converter [36]. This refers to the loss of stability of a fixed point in the averaged sense bifurcating into a limit cycle. v_1 , v_2 , and i_1 are the state variables of the system and, in this case, are the two capacitor voltages and the inductor current in a Ćuk converter circuit. (a) Trajectory spiralling into stable period-1 orbit or fixed point in the averaged sense. (b) Stable period-1 orbit enlarged (fixed point in the averaged sense). (c) Trajectory spiralling away from the unstable period-1 orbit (fixed point in the averaged sense) after a Hopf bifurcation. (d) Limit cycle reached by the trajectory of (c).

show the limitations of such a model in describing high-frequency behavior such as the period-doubling phenomena observed in the real circuit. Likewise, when sufficient evidence has been collected from experiments and simulations that a low-frequency limit cycle originates from a Hopf bifurcation, the use of an averaged model will adequately yield consistent predictions.

As mentioned earlier in Section III, switching converters can exhibit a variety of nonlinear phenomena depending upon the circuit topology and the control method used. From what has been reported so far in the literature, the following general observations can be made.

- 1) Voltage-mode controlled buck converters typically undergo period-doubling bifurcations [13], [22], [23], whereas boost converters are more likely to exhibit Hopf or Neimark–Sacker bifurcation [36], [48].
- 2) Period doubling is also common in buck- or boost-type converters operating in discontinuous-mode [19]–[21] and current-mode controlled converters [24], [25].
- 3) A variety of bifurcations are possible when other nonlinear control methods are used, e.g., crisis, saddle-node bifurcation, switching-time bifurcation, etc. [15], [37], [38].

- 4) Nonsmooth bifurcations such as border collisions are often present and are essential in organizing the overall bifurcation pattern observed in the converters [27], [34].

To conclude the discussion on standard bifurcations, let us take a look at some typical bifurcations observed in switching power converters. Fig. 6 shows a Hopf bifurcation observed from a free-running Ćuk converter. Prediction by an averaged model and corresponding experimental measurements are found in [36]. Also, Fig. 7 captures the disruption of standard period-doubling cascades by border collision in a current-controlled boost converter. Analysis of current-mode controlled converters by the iterative-map approach can be found in [24], [25], and [29].

C. Analysis of Border Collisions, Grazings, and Other Nonsmooth Bifurcations

We have seen that power converters can exhibit standard bifurcations together with abrupt transitions due to border collisions and other nonsmooth bifurcations (or *C*-bifurcations), which are associated with interactions between the system trajectories and so-called switching manifolds.

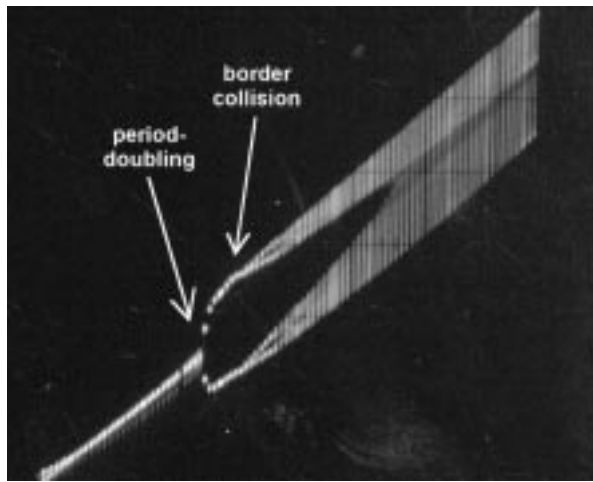

(a)

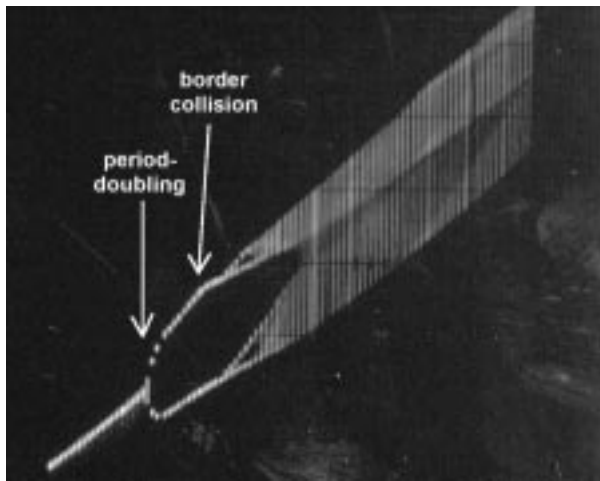

(b)

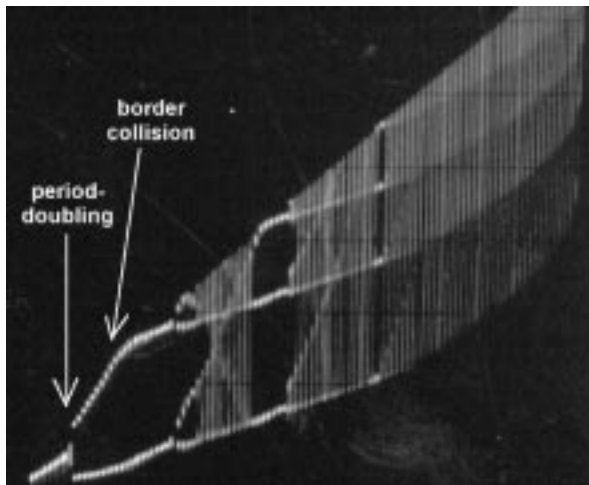

(c)

Fig. 7. Period-doubling cascade interrupted by a border collision. Dimensionless parameter that is relevant to this bifurcation is T/CR [27]. From (a) to (c), the output capacitor gradually changes from a large value to a small value. (a) $T/CR = 0.0025$. (b) $T/CR = 0.0256$. (c) $T/CR = 0.2564$.

Specifically, for continuous-time switched dynamical systems, a dramatic change of the system behavior is usually observed when a part of the system trajectory hits one of the

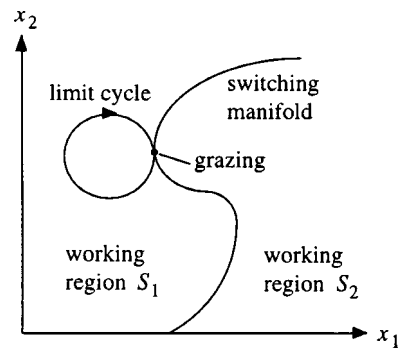

(a)

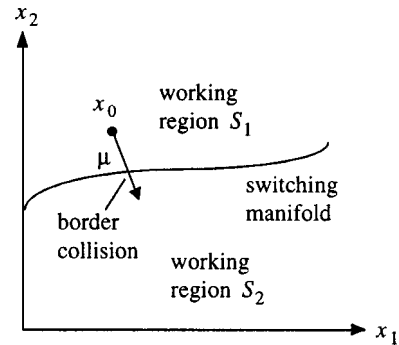

(b)

Fig. 8. Schematic representation of (a) grazing (continuous time) and (b) border collision (discrete time).

boundaries in the phase space (or switching manifolds) associated with a change of the system configuration. Fig. 8(a) illustrates this situation. When this occurs, the system is said to undergo a *grazing* bifurcation [33], [55]–[58], [63]. Equivalently, for systems modeled by iterative maps, sudden transitions from one evolution to the other are associated with fixed points crossing one of the switching manifolds. This event is termed *border collision* [27], [28], [31], [32], as shown in Fig. 8(b). Through the use of appropriate Poincaré maps, grazing bifurcations and border collisions can be unified under the same theoretical framework [60]. It can be shown that grazing bifurcations and border collisions are actually equivalent if the continuous-time system trajectory interacts with a discontinuous switching manifold (e.g., a ramp signal) [59]. In what follows, we will simply refer to this type of bifurcations as border collisions.

As mentioned above, in switching power converters, the occurrence of border collisions, for example, is often due to the limiting effect of the pulse-width modulation process or in general to the limited range within which a standard bifurcation cascade can be allowed to grow. At the edge of this limit, such as in the case shown earlier where the control signal “grazes” the tip of the ramp signal in the usual pulse-width modulator, a border collision occurs. These bifurcations can have many possible consequences. For instance, a periodic orbit can disappear or give rise to the sudden appearance of chaotic regimes. Predicting the type of scenario resulting from a border collision that can be observed in the system under investigation is particularly important in applications.

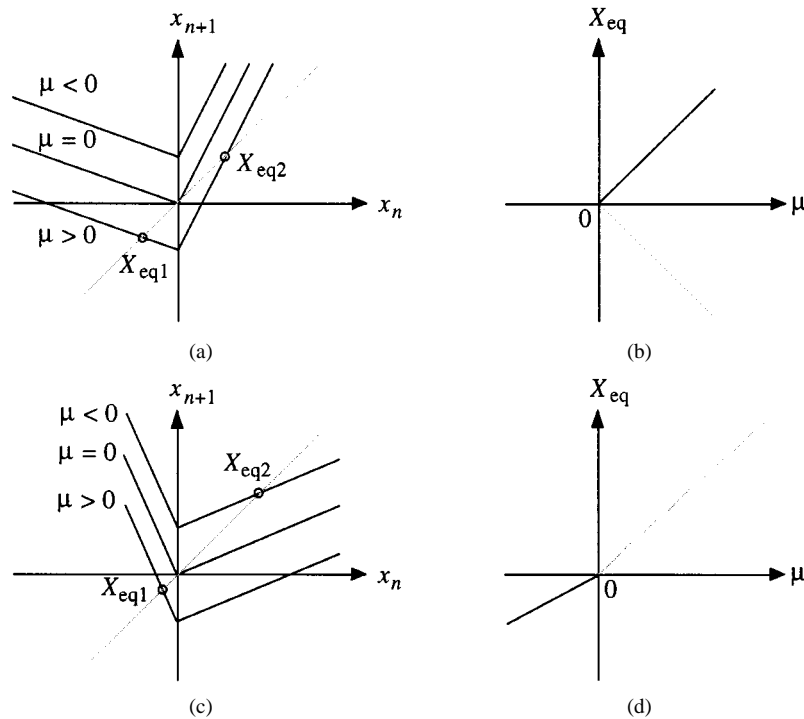

Fig. 9. Classification of border collisions in a 1-D map. Scenario observed at a border collision ($\mu = 0$) depends on the slopes of the map sections. (b) Saddle-node like scenario is observed as the map (a) crosses the boundary $x = 0$. (d) Change in the map slopes leads to different scenarios (c).

In Section V-D, we present a simplified classification strategy of border collisions, the purpose being to enable one to predict the scenario following a border collision as one or more of the system parameters are varied.

D. Classification of Border Collisions

The problem of finding appropriate strategies to classify border-collision bifurcations is the subject of much ongoing research. A complete classification for one-dimensional (1-D) and two-dimensional maps has been presented by Nusse *et al.* [31] and more recently by Banerjee and Grebogi [64]. For higher dimensional systems, no complete classification strategy is available yet. A first strategy to classify border collisions in systems with any number of states was reported by Di Bernardo *et al.* [61]. The aim of all classification methods is to provide a link between some properties of the system under investigation and the scenarios observed after the bifurcation of interest. In what follows, we briefly summarize the key results concerning the classification of border collision in n -dimensional switched dynamical systems (see [61] for further details).

When the system Jacobian is discontinuous at the border-collision point, the key step to classify border collision is the linearization of the system about the bifurcation point in the two regions across the discontinuity boundary. More specifically, suppose that for some parameter value $\mu = \mu_0$, a fixed point, say, x_0 , crosses the switching manifold causing a border collision to occur, as shown in Fig. 8(b). Further, assume that for $\mu < \mu_0$, x_0 is in region S_1 and when $\mu > \mu_0$, x_0 is in region S_2 . Then, the system can be linearized about x_0

in regions S_1 and S_2 . After an appropriate coordinate transformation, the linearized system can be written in the form

$$x_{n+1} = \begin{cases} A_1 x_n + B\mu, & \text{if } c^T x_n < 0 \\ A_2 x_n + B\mu, & \text{if } c^T x_n > 0 \end{cases} \quad (13)$$

where A_1 , A_2 , B and c are the system matrices and vectors of appropriate dimensions.

An appropriate classification of border collisions can then be obtained in terms of the matrices A_1 , A_2 , B , and c . Fig. 9 shows a graphical interpretation for the case of a 1-D system. In general, the scenario following a border collision can be predicted by studying the eigenvalues of the matrices characterizing the linearized system [61], [64]. For instance, one may predict a “jump” from a period-1 orbit to chaos, a period-1 orbit to another period-1 orbit, etc.

E. Sliding

Recently, a peculiar type of behavior unique to nonsmooth systems, termed *sliding*, has been studied in switching converters. Sliding can be understood as a solution characterized by a large number of switchings (ideally infinite) between different system configurations. Because of this high-frequency switching behavior, the system trajectory will remain close to the switching manifold. For instance, in a pulse-width modulator, where a ramp signal is compared with a control signal, sliding is characterized by the control signal crossing the ramp repeatedly from above and below.

The presence of sliding can give rise to the formation of so-called sliding orbits, i.e., periodic solutions characterized

by sections of sliding motion (or chattering). These solutions can play an important role in organizing the dynamics of a given power electronics circuit [35]. Research is still ongoing in identifying a novel class of bifurcations, called *sliding bifurcations*, which involve interactions between the system trajectories and discontinuity sets where sliding motion is possible [66].

Note that practitioners often include so-called *latch* flip-flops in their design in order to avoid the occurrence of repeated switching (or multiple pulsing). It can be shown that when sliding is possible, the introduction of these devices can lead to worse dynamical scenarios such as high-amplitude chaotic oscillations (see [67]).

VI. CURRENT STATUS AND FUTURE WORK

A. Current Status

Research in nonlinear phenomena of power electronics can be said to have gone through its first phase of development. Most of the work reported so far has focused on identifying bifurcations and nonlinear phenomena and explaining them using the theory of nonlinear dynamics. The research activity of the past decade has served a two-fold purpose. First, it has shown to engineers that the commonly observed “strange” phenomena (e.g., chaos and bifurcations) in power electronics can be characterized and treated systematically, rather than being considered as just “bad” laboratory observations. Second, the proliferation of publications in this area has demonstrated the richness of dynamical behavior exhibited by power electronics, posing new interesting challenges to the nonlinear system theorists [56], [60], [61], [64], [68], [69].

It seems that identification and classification work will continue to be an important area of investigation. This is because power electronics emphasizes reliability and predictability and it is imperative to understand the system behavior as thoroughly as possible and under all kinds of operating conditions. Knowing when and how a certain bifurcation occurs, for example, will provide useful information to derive appropriate strategies to avoid it or even exploit its occurrence. Moreover, power electronics is an emerging discipline; new circuits and applications are generated every day. The lack of general solutions for nonlinear problems means that each new system has to be treated separately and the growing complexity of power electronics applications makes it of utmost importance to understand the nonlinear behavior of such kinds of systems.

B. Using Chaos in Power Electronics—Electromagnetic Interference Suppression and System Design

Future research will inevitably move toward any profitable exploitation of the nonlinear properties of power electronics. As a start, some applications of chaotic power electronics systems and related theory have been identified, for instance, in the control of electromagnetic interference (EMI) by “spreading” the noise spectrum [70]–[74], in the application of “targeting” orbits with less iterations (i.e., directing trajectories to certain orbits in as little time as

possible) [75], and in the stabilization of periodic operations [76].

Among the applications of chaos in power electronics that have been proposed so far, the suppression of EMI has attracted considerable attention because of the practical importance of avoiding excessive spectrum spikes. In recent years, international regulatory standards have imposed stringent requirements on the maximum noise level that can be allowed for most power electronics products. To meet these requirements, the use of chaos may provide a quick solution by lowering the spectrum peaks. It has been shown (see, e.g., [74]) that by “chaotifying” either the switching frequency or some relevant switching subinterval(s) around a nominal value, the amplitudes of the peaks in the noise spectrum can be reduced. However, further work is still needed to make the technique truly viable since the use of chaos merely readjusts the spectrum to avoid excessive spectrum spikes, but does not reduce the overall noise power emitted. Thus, from the engineering viewpoint, the problem of EMI cannot be claimed to have been fully fixed.

Furthermore, from the body of knowledge we have already gathered for some specific practical power electronics systems, it is timely for researchers to consider putting the results to engineering use. For example, the results concerning the bifurcation of power converters can be systematically collected to form a design guide that can help identify the parameter ranges within which a particular system can remain in a given operating regime. This area is still rarely addressed in the literature, despite its practical importance.

VII. CONCLUSION

In this paper, we have reviewed the major findings over the past decade in the study of nonlinear behavior of power electronics. In particular, we have presented:

- 1) a survey of the key publications, highlighting the salient aspects of research in the identification of chaotic and bifurcation behavior;
- 2) an overview of the key modeling approaches that have been pivotal in the development of the field;
- 3) an overview of the bifurcation phenomena in switching power converters, emphasizing the role that non-smooth bifurcations such as border collisions play in organizing the overall bifurcation patterns.

As new applications continue to emerge in power electronics, new nonlinear problems are posed. The development of analytical methods to characterize such problems will continue to advance. At the current rate of development, we expect and hope to see meaningful applications of the nonlinear study of power converters to be reported soon in the literature. This should be the ultimate aim of all the past efforts spent in characterizing the nonlinear dynamics of power electronics circuits and systems.

REFERENCES

- [1] B. K. Bose, Ed., *Modern Power Electronics: Evolution, Technology, and Applications*. Piscataway, NJ: IEEE Press, 1992.
- [2] *Proceedings of the Annual IEEE Applied Power Electronics Conference and Exposition (APEC)*. Piscataway, NJ: IEEE Press, 1986.

- [3] *Records of Annual IEEE Power Electronics Specialists Conference (PESC)*. Piscataway, NJ: IEEE Press, 1970.
- [4] R. D. Middlebrook and S. Čuk, "A general unified approach to modeling switching-converter power stages," in *Proc. IEEE Power Electronics Specialists Conf.*, 1976, pp. 18–34.
- [5] P. R. Severns and G. E. Bloom, *Modern DC-to-DC Switchmode Power Converter Circuits*. New York: Van Nostrand Reinhold, 1985.
- [6] P. T. Krein, *Elements of Power Electronics*. New York: Oxford Univ. Press, 1998.
- [7] J. Foutz. (1996) Chaos in power electronics. *SMPs Technology Knowledge Base* [Online]. Available: <http://www.smpstech.com/chaos000.htm>.
- [8] D. C. Hamill, "Power electronics: a field rich in nonlinear dynamics," in *Proc. Int. Workshop Nonlinear Electronics Systems*, Dublin, Ireland, 1995, pp. 165–178.
- [9] D. C. Hamill and D. J. Jefferies, "Subharmonics and chaos in a controlled switched-mode power converter," *IEEE Trans. Circuits Syst. I*, vol. 35, pp. 1059–1061, Aug. 1988.
- [10] J. H. B. Deane and D. C. Hamill, "Instability, subharmonics and chaos in power electronics systems," in *Proc. IEEE Power Electronics Specialists Conf.*, 1989, pp. 34–42.
- [11] —, "Instability, subharmonics and chaos in power electronics systems," *IEEE Trans. Power Electron.*, vol. 5, no. 3, pp. 260–268, 1990.
- [12] P. T. Krein and R. M. Bass, "Types of instabilities encountered in simple power electronics circuits: Unboundedness, chattering and chaos," in *Proc. IEEE Applied Power Electronics Conf.*, 1990, pp. 191–194.
- [13] D. C. Hamill, J. B. Deane, and D. J. Jefferies, "Modeling of chaotic dc–dc converters by iterated nonlinear mappings," *IEEE Trans. Power Electron.*, vol. 7, pp. 25–36, Jan. 1992.
- [14] J. H. B. Deane and D. C. Hamill, "Chaotic behavior in a current-mode controlled dc–dc converter," *Electron. Lett.*, vol. 27, no. 3, pp. 1172–1173, June 1991.
- [15] D. C. Hamill, S. Banerjee, and G. C. Verghese, "Chapter 1: Introduction," in *Nonlinear Phenomena in Power Electronics*, S. Banerjee and G. C. Verghese, Eds. Piscataway, NJ: IEEE Press, 2001.
- [16] M. di Bernardo and F. Vasca, "Discrete-time maps for the analysis of bifurcations and chaos in dc–dc converters," *IEEE Trans. Circuits Syst. I*, vol. 47, pp. 130–143, Feb. 2000.
- [17] C. K. Tse, "Recent developments in the study of nonlinear phenomena in power electronics," *IEEE Circuits Syst. Soc. Newslett.*, vol. 11, no. 1, pp. 14–48, 2000.
- [18] S. Banerjee and G. C. Verghese, Eds., *Nonlinear Phenomena in Power Electronics*. Piscataway, NJ: IEEE Press, 2001.
- [19] C. K. Tse, "Flip bifurcation and chaos in a three-state boost switching regulator," *IEEE Trans. Circuits Syst. I*, vol. 42, pp. 16–23, Jan. 1994.
- [20] —, "Chaos from a buck switching regulator operating in discontinuous mode," *Int. J. Circuit Theory Appl.*, vol. 22, no. 4, pp. 263–278, 1994.
- [21] W. C. Y. Chan and C. K. Tse, "On the form of control function that can lead to chaos in discontinuous-mode dc–dc converters," in *Proc. IEEE Power Electronics Specialists Conf.*, 1997, pp. 1317–1322.
- [22] K. Chakrabarty, G. Podder, and S. Banerjee, "Bifurcation behavior of buck converter," *IEEE Trans. Power Electron.*, vol. 11, pp. 439–447, May 1995.
- [23] E. Fossas and G. Olivar, "Study of chaos in the buck converter," *IEEE Trans. Circuits Syst. I*, vol. 43, pp. 13–25, Jan. 1996.
- [24] J. H. B. Deane, "Chaos in a current-mode controlled dc–dc converter," *IEEE Trans. Circuits Syst. I*, vol. 39, pp. 680–683, Aug. 1992.
- [25] W. C. Y. Chan and C. K. Tse, "Study of bifurcation in current-programmed boost dc–dc converters: From quasi-periodicity to period doubling," *IEEE Trans. Circuits Syst. I*, vol. 44, pp. 1129–1142, Dec. 1997.
- [26] C. K. Tse and W. C. Y. Chan, "Chaos from a current-programmed Čuk converter," *Int. J. Circuit Theory Appl.*, vol. 23, no. 3, pp. 217–225, 1995.
- [27] S. Banerjee, E. Ott, J. A. Yorke, and G. H. Yuan, "Anomalous bifurcation in dc–dc converters: Borderline collisions in piecewise smooth maps," in *Proc. IEEE Power Electronics Specialists Conf.*, 1997, pp. 1337–1344.
- [28] G. H. Yuan, S. Banerjee, E. Ott, and J. A. Yorke, "Border collision bifurcation in the buck converter," *IEEE Trans. Circuits Syst. I*, vol. 45, pp. 707–716, July 1998.
- [29] S. Banerjee, P. Ranjan, and C. Grebogi, "Bifurcation in two-dimensional piecewise smooth maps—Theory and applications in switching circuits," *IEEE Trans. Circuits Syst. I*, vol. 47, pp. 633–643, May 2000.
- [30] M. di Bernardo, F. Garofalo, L. Glielmo, and F. Vasca, "Switchings, bifurcations and chaos in dc–dc converters," *IEEE Trans. Circuits Syst. I*, vol. 45, pp. 133–141, Feb. 1998.
- [31] H. E. Nusse and J. A. Yorke, "Border-collision bifurcations for piecewise-smooth one-dimensional maps," *Int. J. Bifur. Chaos*, vol. 5, no. 1, pp. 189–207, Jan. 1995.
- [32] —, "Border-collision bifurcations including 'period two to period three' for piecewise smooth systems," *Physica D*, vol. 57, no. 1–2, pp. 39–57, Jan. 1992.
- [33] A. B. Nordmark, "Non-periodic motion caused by grazing incidence in an impact oscillator," *J. Sound Vib.*, vol. 145, no. 2, pp. 279–297, Mar. 1991.
- [34] M. di Bernardo, F. Garofalo, L. Glielmo, and F. Vasca, "Quasi-periodic behaviors in dc–dc converters," in *Proc. IEEE Power Electronics Specialists Conf.*, 1996, pp. 1376–1381.
- [35] M. di Bernardo, C. J. Budd, and A. R. Champneys, "Grazing, skipping and sliding: Analysis of the nonsmooth dynamics of the dc–dc buck converter," *Nonlinearity*, vol. 11, no. 4, pp. 858–890, 1998.
- [36] C. K. Tse, Y. M. Lai, and H. H. C. Iu, "Hopf bifurcation and chaos in a free-running current-controlled Čuk switching regulator," *IEEE Trans. Circuits Syst. I*, vol. 47, pp. 448–457, Apr. 2000.
- [37] A. Magauer and S. Banerjee, "Bifurcations and chaos in the tolerance-band pwm technique," *IEEE Trans. Circuits Syst. I*, vol. 37, pp. 399–409, Mar. 1990.
- [38] S. Jalali, I. Dobson, R. H. Lasseter, and G. Venkataramanan, "Switching time bifurcation in a thyristor controlled reactor," *IEEE Trans. Circuits Syst. I*, vol. 43, pp. 209–218, Mar. 1996.
- [39] Y. Kuroe and S. Hayashi, "Analysis of bifurcation in power electronic induction motor drive system," in *Proc. IEEE Power Electronics Specialists Conf.*, 1989, pp. 923–930.
- [40] Z. Süto, I. Nagy, and E. Masada, "Avoiding chaotic processes in current control of ac drive," in *Proc. IEEE Power Electronics Specialists Conf.*, 1998, pp. 255–261.
- [41] H. H. C. Iu and C. K. Tse, "Instability and bifurcation in parallel-connected buck converters under a master–slave current-sharing scheme," in *Proc. IEEE Power Electronics Specialists Conf.*, 2000, pp. 708–713.
- [42] H. H. C. Iu, C. K. Tse, V. Pjevalica, and Y. M. Lai, "Bifurcation behavior in parallel-connected boost converters," *Int. J. Circuit Theory Appl.*, vol. 29, no. 3, pp. 281–298, 2001.
- [43] C. Hayashi, *Nonlinear Oscillations in Physical Systems*. Princeton University Press, 1964.
- [44] R. Oruganti and F. C. Lee, "State-plane analysis of parallel resonant converter," in *Proc. IEEE Power Electronics Specialists Conf.*, 1985, pp. 56–73.
- [45] S. R. Sanders and G. C. Verghese, "Lyapunov-based control of switched power converters," in *Proc. IEEE Power Electronics Specialists Conf.*, 1990, pp. 51–58.
- [46] R. Tymerski, "Volterra series modeling of power conversion systems," in *Proc. IEEE Power Electronics Specialists Conf.*, 1990, pp. 786–791.
- [47] S. K. Mazumder, A. H. Nayfeh, and D. Borojevich, "Theoretical and experimental investigation of the fast- and slow-scale instabilities of a dc–dc converter," *IEEE Trans. Power Electron.*, vol. 16, pp. 201–216, Mar. 2001.
- [48] A. El Aroudi, "Hopf bifurcation and chaos from torus breakdown in a pwm voltage-controlled dc–dc boost converters," *IEEE Trans. Circuits Syst. I*, vol. 46, pp. 1374–1382, Nov. 1999.
- [49] S. Wiggins, *Introduction to Applied Nonlinear Dynamical Systems and Chaos*. New York: Springer-Verlag, 1990.
- [50] J. Guckenheimer and P. J. Holmes, *Nonlinear Oscillations, Dynamical Systems and Bifurcations of Vector Fields*. New York: Springer-Verlag, 1997.
- [51] K. T. Alligood, T. D. Sauer, and J. A. Yorke, *Chaos: Introduction to Dynamical Systems*. New York: Springer-Verlag, 1996.
- [52] E. Ott, *Chaos in Dynamical Systems*. Cambridge, UK: Cambridge Univ. Press, 1993.
- [53] P. G. Drazin, *Nonlinear Systems*. Cambridge, UK: Cambridge Univ. Press, 1992.
- [54] B. Brogliato, *Nonsmooth Mechanics*. New York: Springer-Verlag, 1998.
- [55] A. B. Nordmark, "Non-periodic motion caused by grazing incidence in impact oscillators," *J. Sound Vib.*, vol. 2, pp. 279–297, 1991.

- [56] M. I. Feigin, "Doubling of the oscillation period with C-bifurcations in piecewise continuous systems," *J. Appl. Math. Mech. (PMM)*, vol. 34, no. 6, pp. 861–869, Nov. 1970.
- [57] —, "On the generation of sets of subharmonic modes in a piecewise continuous system," *J. Appl. Math. Mech. (PMM)*, vol. 38, no. 6, pp. 810–818, Nov. 1974.
- [58] —, "On the structure of C-bifurcation boundaries of piecewise continuous systems," *J. Appl. Math. Mech. (PMM)*, vol. 2, no. 6, pp. 820–829, Nov. 1978.
- [59] M. di Bernardo, C. J. Budd, and A. R. Champneys, "Corner collision implies border collision," *Physica D*, vol. 154, no. 3–4, pp. 171–194, June 2001.
- [60] —, "Grazing and border-collision in piecewise-smooth systems: A unified analytical framework," *Phys. Rev. Lett.*, vol. 86, no. 12, pp. 2553–2556, 2000.
- [61] M. di Bernardo, M. I. Feigin, S. J. Hogan, and M. E. Homer, "Local analysis of C-bifurcations in n -dimensional piecewise smooth dynamical systems," *Chaos Solitons Fractals*, vol. 10, no. 11, pp. 1881–1908, 1999.
- [62] M. I. Feigin, "The increasingly complex structure of the bifurcation tree of a piecewise-smooth system," *J. Appl. Math. Mech.*, vol. 59, no. 6, pp. 853–863, Nov. 1995.
- [63] M. di Bernardo, C. J. Budd, and A. R. Champneys, "Normal form maps of grazing bifurcations in n -dimensional piecewise smooth systems," *Physica D*, vol. 160, no. 3–4, pp. 222–254, Dec. 2001.
- [64] S. Banerjee and C. Grebogi, "Border collision bifurcations in two-dimensional piecewise smooth maps," *Phys. Rev. E*, vol. 59, no. 4, pp. 4052–4061, Apr. 1999.
- [65] H. E. Nusse, E. Ott, and J. A. Yorke, "Border collisions bifurcations—An explanation for observed bifurcation phenomena," *Phys. Rev. E*, vol. 49, no. 2, pp. 1073–1076, Feb. 1994.
- [66] M. di Bernardo, K. H. Johansson, and F. Vasca, "Self-oscillations in relay feedback systems: Symmetry and bifurcations," *Int. J. Bifur. Chaos*, vol. 11, no. 4, pp. 1121–1140, 2001.
- [67] S. Myles and M. di Bernardo, "Preventing multiple switchings in power electronic circuits: Effects of the latch on the nonlinear dynamics of the dc–dc buck converter," *Int. J. Bifur. Chaos*, vol. 10, no. 2, pp. 431–442, Feb. 2000.
- [68] T. Kousaka, T. Ueta, and H. Kawakami, "Bifurcation in switched nonlinear dynamical systems," *IEEE Trans. Circuits Syst. II*, vol. 46, pp. 878–885, July 1999.
- [69] M. di Bernardo, "The complex behavior of switching devices," *IEEE Circuits Syst. Soc. Newslett.*, vol. 10, no. 4, pp. 1–13, 1999.
- [70] F. Ueno, I. Oota, and I. Harada, "A low-noise control circuit using chua's circuit for a switching regulator," in *Proc. Eur. Conf. Circuit Theory Design*, 1995, pp. 1149–1152.
- [71] J. H. B. Deane and D. C. Hamill, "Improvement of power supply EMC by chaos," *Electron. Lett.*, vol. 32, no. 12, p. 1045, 1996.
- [72] R. Giral, A. El Aroudi, L. Martinez-Salamero, R. Leyva, and J. Maixe, "Current control technique for improving EMC in power converters," *Electron. Lett.*, vol. 37, no. 5, pp. 274–275, 2001.
- [73] A. L. Baranovski, A. M̄gel, W. Schwarz, and O. Woywode, "Chaotic control of a dc–dc converter," in *Proc. IEEE Int. Symp. Circuits and Systems*, 2000, pp. 108–112.

- [74] G. Setti, R. Rovatti, S. Callegari, and A. Bellini, "Chaos-based generation of low-EMI pwm control signals for induction motor drives," in *Proc. Int. Symp. Nonlinear Theory and its Applications*, 2001, pp. 629–632.
- [75] P. J. Aston, J. H. B. Deane, and D. C. Hamill, "Targeting in systems with discontinuities, with applications to power electronics," *IEEE Trans. Circuits Syst. I*, vol. 44, pp. 1034–1039, Oct. 1997.
- [76] C. Batlle, E. Fossas, and G. Olivar, "Stabilization of periodic orbits of the buck converter by time-delayed feedback," *Int. J. Circuit Theory Appl.*, vol. 27, no. 6, pp. 617–631, Nov. 1999.



Chi K. Tse (Senior Member, IEEE) received the B.Eng. (honors) degree in electrical engineering and the Ph.D. degree from the University of Melbourne, Melbourne, Australia, in 1987 and 1991, respectively.

He is currently a Professor with the Hong Kong Polytechnic University, Kowloon, Hong Kong. Previously, he was in software design with BIS, Australia, and power supplies design with ASTEC, Hong Kong. He authored *Linear Circuit Analysis* (London, UK: Addison-Wesley,

1998) and one U.S. patent. His current research interests include chaotic dynamics and power electronics.

Dr. Tse received the L. R. East Prize by the Institution of Engineers, Australia, in 1997 and the President's Award for Achievement in Research in 1997 and 2000, the Excellent Teacher Award in 1997 and 1999, and the Faculty Best Researcher Award in 2000 from the Hong Kong Polytechnic University. He is an Associate Editor of *IEEE TRANSACTIONS ON POWER ELECTRONICS* and *IEEE TRANSACTIONS ON CIRCUITS AND SYSTEMS—PART I: FUNDAMENTAL THEORY AND APPLICATIONS*.



Mario di Bernardo (Member, IEEE) was born in Naples, Italy, on May 11, 1970. He received a five-year degree in electronic engineering from the University of Naples Federico II, Naples, Italy, in 1994 and the Ph.D. degree in applied mathematics and control from the University of Bristol, Bristol, U.K., in 1998.

He was a Lecturer of Nonlinear Systems with the Department of Engineering Mathematics, University of Bristol. He is currently with the Department of Engineering, University of

Sannio, Benevento, Italy. He has authored or coauthored several papers in journals and books and is well known for his work on piecewise-smooth dynamical systems and adaptive control of bifurcations and chaos. His current research interests include the broad area of nonlinear systems, on both dynamics and control.

Dr. di Bernardo is Associate Editor of the *IEEE TRANSACTIONS ON CIRCUITS AND SYSTEMS—PART I: FUNDAMENTAL THEORY AND APPLICATIONS*.