



Theses and Dissertations

2014-08-25

Compliant Joints Suitable for Use as Surrogate Folds

Isaac L. Delimont
Brigham Young University - Provo

Follow this and additional works at: <https://scholarsarchive.byu.edu/etd>



Part of the [Mechanical Engineering Commons](#)

BYU ScholarsArchive Citation

Delimont, Isaac L., "Compliant Joints Suitable for Use as Surrogate Folds" (2014). *Theses and Dissertations*. 4231.

<https://scholarsarchive.byu.edu/etd/4231>

This Thesis is brought to you for free and open access by BYU ScholarsArchive. It has been accepted for inclusion in Theses and Dissertations by an authorized administrator of BYU ScholarsArchive. For more information, please contact scholarsarchive@byu.edu, ellen_amatangelo@byu.edu.

Compliant Joints Suitable for Use as Surrogate Folds

Isaac L. Delimont

A thesis submitted to the faculty of
Brigham Young University
in partial fulfillment of the requirements for the degree of
Master of Science

Spencer P. Magleby, Chair
Larry L. Howell
Brian D. Jensen

Department of Mechanical Engineering
Brigham Young University
August 2014

Copyright © 2014 Isaac L. Delimont
All Rights Reserved

ABSTRACT

Compliant Joints Suitable for Use as Surrogate Folds

Isaac L. Delimont

Department of Mechanical Engineering, BYU

Master of Science

Origami-inspired design is an emerging field capable of producing compact and efficient designs. The object of a surrogate fold is to provide a fold-like motion in a non-paper material without undergoing yielding. Compliant mechanisms provide a means to achieve these objectives as large deflections are achieved. The purpose of this thesis is to present a summary of existing compliant joints suitable for use as surrogate folds. In doing so, motions are characterized which no existing compliant joint provides. A series of compliant joints is proposed which provides many of these motions. The possibility of patterning compliant joints to form an array is discussed. Arrays capable of producing interesting motions are noted.

Keywords: compliant mechanisms, origami-inspired design, surrogate folds, flexible hinge, monolithic hinge, lamina emergent mechanism

ACKNOWLEDGMENTS

I express appreciation to Dr. Spencer Magleby for his support as a thesis advisor along with Dr. Larry Howell and Dr. Brian Jensen for their encouragement and advice as committee members.

I also express appreciation to my wife, Katrina Delimont, for her patience and support as I pursue a graduate degree.

I acknowledge the contributions of my fellow students in the Compliant Mechanisms Research group, whose spirit of cooperation greatly facilitated my research. Among these students I recognize Ezekial Merriam, Jordon Tanner, and Thomas Evans for their assistance deriving the governing equations for the dual-segment joint, and Jason Lund for his valuable help with ANSYS.

This material is based on work supported by the National Science Foundation and the Air Force Office of Scientific Research under NSF Grant No. 1240417.

Chapter 2 has been submitted for publication at ASME International Design and Engineering Technical Conferences and Computers and Information in Engineering Conference under the title *Evaluating Compliant Hinge Geometries for Origami-Inspired Mechanisms* with Dr. Spencer Magleby and Dr. Larry Howell as coauthors.

Chapter 3 has been submitted for publication by the ASME Journal of Mechanical Design under the title *A Family of Dual-Segment Compliant Joints Suitable as Surrogate Folds* with Dr. Spencer Magleby and Dr. Larry Howell as coauthors.

TABLE OF CONTENTS

LIST OF TABLES	vi
LIST OF FIGURES	vii
Chapter 1 Introduction	1
1.1 Origami-Inspired Design	1
1.2 Compliant Mechanisms	2
1.3 Surrogate Folds	2
1.4 Research Objectives	3
Chapter 2 Existing Surrogate Folds	5
2.1 Introduction	5
2.2 Metrics	6
2.3 Selection Guide	7
2.4 Groove Joint	8
2.5 Simple Reduced-Area Joint	10
2.6 Outside LET	11
2.7 Inside LET	14
2.8 Inverted Lamina Emergent Joint	15
2.9 Tension Lamina Emergent Joint	17
2.10 Revolute U-form Flexure	19
2.11 Torsional U-form Flexure	20
2.12 Conclusions	20
Chapter 3 A Family of Dual-Segment Compliant Joints Suitable as Surrogate Folds .	23
3.1 Introduction	23
3.2 Background	24
3.3 A Continuum of Dual-Segment Compliant Joints	25
3.4 Bending-Orthogonal Joint ($\phi = 0^\circ$)	30
3.5 Mixed Tension Resistant Joint ($\phi = 0-90^\circ$)	31
3.6 Torsion-Parallel Joint ($\phi = 90^\circ$)	34
3.7 Mixed Compression Resistant Joint ($\phi = 90-180^\circ$)	35
3.8 Inverted Bending-Orthogonal Joint ($\phi = 180^\circ$)	37
3.9 Combined Compliant Joints as Surrogate Folds	37
3.9.1 Torsion-Parallel Joint with Buckling Member	41
3.9.2 Lateral Bending	41
3.10 Compliant Joint Arrays as Surrogate Folds	43
3.11 Design of Surrogate Folds	45
3.12 Conclusion	46
Chapter 4 Conclusion	47

REFERENCES 49

LIST OF TABLES

2.1	Equations describing surrogate fold motion.	20
2.2	Surrogate folds and their secondary motions. For the five motions grey boxes indicate high stiffness resisting that motion. For large deflections grey indicates the surrogate fold	22
3.1	Geometries and responses of compliant joints as ϕ changes. Columns four, five, and six list the loading condition of the compliant members when the joint is loaded as	26
3.2	Compliant joints and their secondary motions. Grey boxes indicate high stiffness resisting that motion while white boxes show the compliant joint in its deflected state	39

LIST OF FIGURES

1.1	Six possible motions of surrogate folds to be compared for each joint. (a) folding, (b) torsion, (c) lateral bending, (d) shear, (e) compression, (f) tension.	3
2.1	Guide for the selection of surrogate folds. All surrogate folds presented are flexible in folding. If another motion is desired, it is selected from the second column. . . .	8
2.2	The Groove Joint with critical parameters labeled.	9
2.3	The Simple Reduced-Area Joint with critical parameters labeled.	10
2.4	The Outside LET Joint with critical parameters labeled.	12
2.5	Equivalent spring diagram for Outside LET in folding. K_B and K_T are torsional spring constants shown as linear for ease of visualization.	12
2.6	Spring diagram for Outside LET in tension and compression. Each torsional spring has a stiffness of K_{fg} as defined by Equation (2.13).	13
2.7	The Inside LET with critical parameters labeled.	14
2.8	The spring diagram for the Inside LET in folding.	15
2.9	The Inverted Lamina Emergent Joint (I-LEJ) with critical parameters labeled. . . .	15
2.10	The Tension Lamina Emergent Joint (T-LEJ) with critical parameters labeled. . . .	17
2.11	The Revolute U-form Flexure (RUFF) with critical parameters labeled.	18
2.12	The Torsional U-form Flexure.	19
3.1	The parameter ϕ affects the response of the surrogate fold to tension and compression.	24
3.2	The pseudo-rigid body equivalent of a surrogate fold.	24
3.3	Comparison of Equation (3.3) and FEA results for varying values of ϕ from 0 to 90 degrees. The compliant members of the joint have a length of $L = 5$ cm, $w = 0.4$ cm, and $t = 0.4$ cm, $E = 1.4$ GPa, and $\nu = 0.34$	27
3.4	The error of Equation (3.3) vs β for a variety of cross sections and lengths.	28
3.5	There exists some value of β such that the stiffness to actuate the dual-segment joint is independent of ϕ	29
3.6	Deflection stiffness to actuate the dual-segment joint vs. the angle ϕ as given by Equation (3.3).	29
3.7	When $\phi = 0$, the dual-segment joint is called the Bending-Orthogonal Joint, also called the Simple Reduced Area Joint.	30
3.8	The addition of a center buckling member to the mixed tension resistant, labelled L_B , decreases the force required to actuate the joint in compression.	31
3.9	The actuation force vs. deflection for the Mixed Tension Resistant Joint in tension and compression. $\phi = 25^\circ$, $L_t = 38.07$ mm, $w = 3.18$ mm, $t = 3.43$ mm, $E = 1.37$ GPa.	32
3.10	An illustration of the boundary conditions used to derive Equation (3.7).	33
3.11	The Torsion-Parallel Joint is a specialized case of the dual-segment joint when ϕ is equal to 90°	34
3.12	The Mixed Compression Resistant Joint gives a stiffer resistance to compression than tension.	35
3.13	The Mixed Compression Resistant Joint rotating out of plane when placed in tension.	36

3.14	The actuation force vs. deflection for the Mixed Compression Resistant Joint in tension and compression. $\phi = 110^\circ$, $L_t = 59$ mm, $w = 3.18$ mm, $t = 1.27$ mm, $E = 1.37$ GPa.	36
3.15	The Inverted Bending-Orthogonal Joint occurs when $\phi = 180$. The inversion causes the compliant members to be in tension when the joint is in compression. This avoids the possibility of buckling in this loading condition.	37
3.16	Guide for the selection of surrogate folds with dual-segment joints included.	38
3.17	The Torsion-Parallel Joint with a buckling member added to give increased resistance to tension and compression as compared to the Outside LET.	40
3.18	A comparison of the Torsion-Parallel Joint with Buckling Member and the Outside LET Joint when placed in tension. Both joints have $L = 5$ cm, $w = 0.4$ cm, $t = 0.4$ cm, and $E = 1.4$ GPa.	40
3.19	Torsion-Parallel Joint patterned along the line of the fold for further increased resistance to tension and compression.	42
3.20	By combining the mixed tension and compression resistant joints a small amount of lateral bending can be achieved while maintaining high resistance to other motions.	42
3.21	An array of Torsion-Parallel Joints in 1.214 mm thick 304 stainless steel capable of achieving 280° rotation (140° each direction) without yielding.	43
3.22	The array shown in Figure 3.21 actuated to beyond 90°	44
3.23	An array of Mixed Compression Resistant Joints to achieve added deflection in the folding motion.	44
3.24	An array of Mixed Tension Resistant Joints providing an increased stiffness to tension compared to compression.	44

CHAPTER 1. INTRODUCTION

1.1 Origami-Inspired Design

Origami, the ancient art of paper folding, involves the folding of paper to create a three dimensional shape. Traditionally origami originates from a single square sheet of paper, which is folded to create unique and attractive shapes. Over centuries of experimentation, a vast array of unique designs have been created. Although the goals of these origami patterns are aesthetic, many origami patterns can provide inspiration for products.

The majority of origami designs are static. However, some origami designs exist that produce a motion. Flapping birds and jumping frogs are among the most popular dynamic origami designs. These dynamic designs have provided the starting point for a number of origami-inspired designs.

Origami-inspired design has led to products to meet challenging design constraints. Such products include: deployable solar arrays for satellite applications [1], medical stents [2], car crash boxes with high crumple zone energy dissipation [3], structural cores for aerospace applications which mitigate water retention in the sandwiched layers [4], airbag folding, and the 100 meter diameter Eyeglass telescope [5]. When size and deployability are critical, origami-inspired designs are particularly useful. Products in the fields of sheet metal forming, architecture, furniture, structural engineering, and medical devices are likely candidates for origami-inspired design [6]. Hence the development of tools to assist in the transition from paper to other materials will be of great use [7].

An origami pattern can be treated as a mechanism where paper panels are treated as rigid bodies and folds function as joints [6–8]. A vertex of four folds can be treated as a spherical mechanism [6]. When origami is treated as a mechanism, the path of the origami can be predicted throughout its motion. These predictions of motion rely on the center of rotation of the fold to be

fixed. While this is an accurate assumption for a fold in paper, this assumption is less true of many surrogate folds.

1.2 Compliant Mechanisms

Compliant mechanisms can provide a transition point between origami and origami-inspired design. Compliant mechanisms involve the flexing of members to achieve all or some of their desired motion [9]. A creased or folded paper can be considered a compliant mechanism [10]. A Lamina Emergent Mechanism (LEM) is a mechanism that emerges from the plane of fabrication but is fabricated in a single plane (lamina). LEMs achieve complex motions but are simple to manufacture [11]. Origami is a LEM because it begins as a single sheet, but through the folding process emerges from a single plane. LEMs have many benefits over more traditional mechanisms. Their monolithic nature allows LEMs to be easily scaled to small sizes. Additionally, LEMs are ideal for micro manufacturing because of their single layer geometries [12]. Because of these properties, many joints used in LEMs can be used effectively as surrogate folds.

1.3 Surrogate Folds

A fold in paper can be defined as a localized reduction in stiffness along the axis of the fold. In paper this reduction in stiffness is achieved through a change in geometry or material properties. The geometry is changed by a reduction in thickness at the fold. Material properties can be changed through delamination of the paper. As a sheet of material becomes thicker, these properties have less of an effect on the overall stiffness of the fold. For this reason, surrogate folds are used to produce a similar motion to folded paper in other materials.

A surrogate fold is a localized reduction in stiffness along the desired axis of rotation, producing a similar motion to a fold in paper. Many compliant joints can be used as surrogate folds. A fold in paper has a fixed center of rotation and can achieve 360° of rotation. Most surrogate folds have non-fixed centers of rotation and achieve smaller deflections. For this reason surrogate folds must be characterized by their response in various motions, allowing the designer to understand the motion of each surrogate fold. The six motions shown in Figure 1.1 will be considered in this research. Folding, the motion shown in Figure 1.1a, is always considered desirable. The remain-

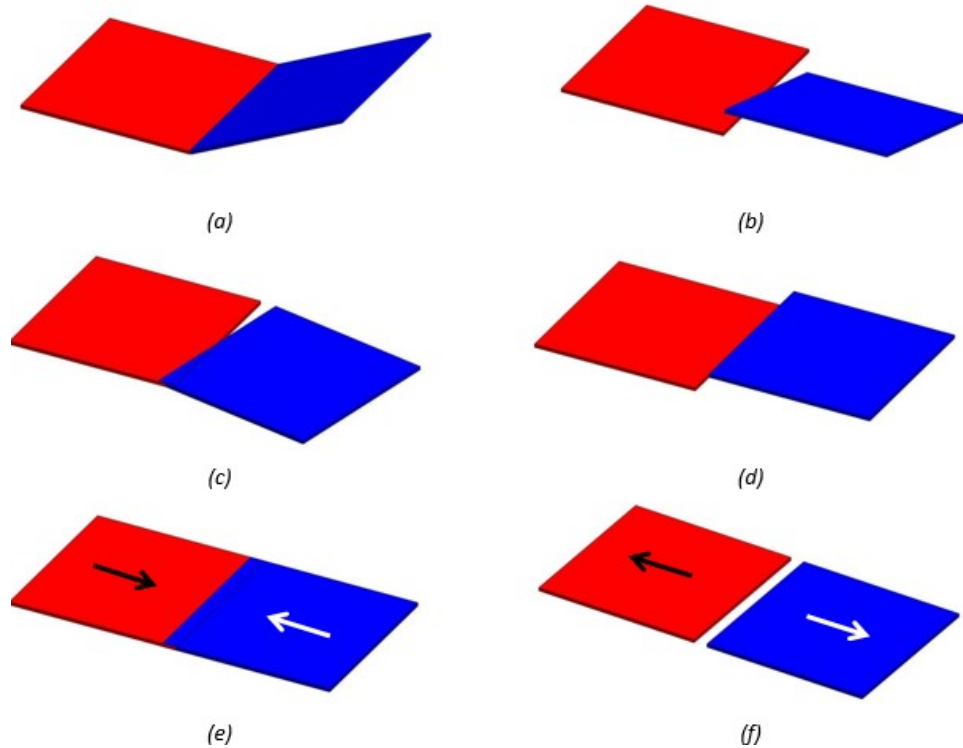

Figure 1.1: Six possible motions of surrogate folds to be compared for each joint. (a) folding, (b) torsion, (c) lateral bending, (d) shear, (e) compression, (f) tension.

ing motions may or may not be desirable depending on the application. These motions include five of the six degrees of freedom. The sixth, translation away from the plane of manufacture, is not anticipated to be a desirable secondary motion.

1.4 Research Objectives

The purpose of this research is to assist designers in transitioning from an origami concept to more traditional engineering materials. This has been accomplished through three distinct contributions.

First, existing surrogate folds are categorized and evaluated as to their desirable applications. These surrogate folds are shown with their critical parameters labelled. Defining equations are given in terms of these critical parameters are presented when closed-form solutions are available.

Second, new surrogate folds are developed to fill deficiencies in the current design space. These deficiencies include the following categories

- A joint that resists compression while allowing tension
- A joint that resists tension while allowing compression
- A joint to resist all secondary motions while maintaining a fixed center of rotation
- A systematic approach to designing for a allowable secondary motion

Finally, new surrogate folds are prototyped and their potential use in design applications discussed. Additionally, CAD models of these surrogate folds are made available to the public on the Compliant Mechanisms Research Group (CMR) website.

CHAPTER 2. EXISTING SURROGATE FOLDS

2.1 Introduction

Origami, the ancient art of paper folding, provides high efficiency in three dimensional geometry creation. A single sheet of material (paper) undergoes folding to create a unique design without assembly. Centuries of experimentation have led to the development of innumerable origami designs. Origami art presents many creative concepts for reconfigurable design [13]. Increasing demand for innovative and compact products has led to the exploration of origami-inspired design.

Origami can be treated as a mechanism where panels are treated as rigid bodies and folds function as joints [6–8] A vertex of four folds can be treated as a spherical mechanism [6]. Unlike more traditional mechanisms, origami designs require only a single manufacturing process (folding). Folding is already a well-established manufacturing method. The packaging industry utilizes the folding of paper and corrugates (i.e. cardboard) to provide lightweight, easily manufactured products. Additionally, these products are typically compact in their unassembled position.

A fold in paper or corrugates can be defined as a decrease in stiffness along the fold axis due to geometry (localized reduction in thickness) and/or material changes such as delamination. Since most materials do not demonstrate these properties when folded, other methods for inducing a localized reduction in stiffness must be employed. Means to replicate the behavior of folded paper is critical for enabling the implementation of further origami-inspired design. To assist in the transition from paper to more typical engineering materials surrogate folds that create a localized reduction in stiffness must be utilized to function in place of a fold. A variety of options exist for use as surrogate folds in origami-inspired design. The purpose of this paper is to organize and evaluate selected surrogate folds for use in origami-inspired design.

Several methods can be utilized to achieve a localized reduction in stiffness. First is a change in geometry. For example, by thinning the material or reducing the cross section at the

location of the desired surrogate fold one can create a localized reduction in stiffness. The second method used to reduce stiffness is changing material properties. Some advanced 3D printing techniques can vary the compliance of a material while maintaining the same cross section. A change in material properties can also be accomplished by incorporating two materials into the work piece, a thicker rigid material and thinner flexible piece. The rigid material can be removed to create a localized reduction in stiffness. The third means for changing stiffness is to modify the boundary conditions. Surrogate folds that achieve their motion through torsion are an example of this. All three techniques are useful when creating surrogate folds.

Surrogate folds can be classified into monolithic and non-monolithic. Monolithic surrogate folds and their adjacent panels are made from a single sheet of material. Monolithic surrogate folds may have advantages in cost and ease of manufacturing. In origami-inspired design, monolithic surrogate folds are typically preferred. Non-monolithic designs generally require additionally assembly. Because of their relative ease of manufacturing, monolithic surrogate folds will be the focus of this paper.

2.2 Metrics

A design guide presenting existing surrogate folds and their benefits would aid in the design of origami-inspired devices and would facilitate the design of new surrogate folds to meet design criteria not currently met by existing surrogate folds. Examples of widely used design guides include Roark's Formulas for Stress and Strain, machinist's handbooks, and design-oriented works in the field of compliant mechanisms [14–17].

To create a suitable design guide for surrogate folds, metrics must first be developed to allow the comparison of surrogate folds. These metrics allow the designer to select the surrogate fold most desirable for a given application. Additionally, this will alert the designer to any undesirable characteristics of a surrogate fold.

Six key motions have been identified which should be considered when designing using surrogate folds. These six motions are illustrated in Figure 1.1. Folding (Figure 1.1a) is considered the desired motion. The remaining five motions are typically considered parasitic or undesirable. It is acknowledged that design scenarios exist in which one or more of these five motions may be

necessary and desirable. For example, some patterns for deployable solar arrays require motion in shear (Figure 1.1d) to fully deploy [1].

In addition to the joints' performance in these six motions, two properties will be considered: stability of center of rotation and angle of rotation. For a fold in paper, the center of rotation is stable and the angle of rotation is large without self-intersection. Few surrogate folds exhibit these properties while resisting all other undesirable motions. For this reason these properties will be catalogued, allowing the designer to compare the surrogate fold to the desired properties for a specific application. The availability of equations governing the motion of a surrogate fold will allow the designer to optimize geometry for stiffness in one motion while allowing motion in another direction. Equations will be developed for the motions most likely to be desired for origami-inspired design applications. The center of rotation will be characterized as stable or unstable and the joint will be rated as suitable or unsuitable for large deflections without self-intersecting.

2.3 Selection Guide

Recommendations for surrogate folds in various applications are presented in the flow chart shown in Figure 2.1. Because geometries and design constraints vary widely, these recommendations are generalizations and will not apply to every situation but are intended as a guide. For example, the Groove Joint may appeal in situations where the length of the fold is tightly constrained. In situations where this constraint is not present the Groove Joint is less desirable. Table 2.2 shows the deformed states of the surrogate folds presented in this paper in their flexible motions. The designer should consult the closed-form solutions for each of these joints to fully understand the effect of geometric changes on the joint behavior. It should be noted that by patterning surrogate folds along the axis of the fold the designer can greatly increase the resistance of the fold to torsion and lateral bending. This can be observed most easily in the Simple Reduced-Area Joint where the resistance of the surrogate fold to torsion and lateral bending motions is a function of the number of bending members.

Monolithic surrogate folds are fabricated from a single sheet of material. The adjacent panels and the joint are a single part. This tends towards rapid, cost-effective manufacture. Where possible monolithic surrogate folds are considered superior to non-monolithic surrogate folds because of the decreased cost and ease of manufacture. Many monolithic joints are suitable for

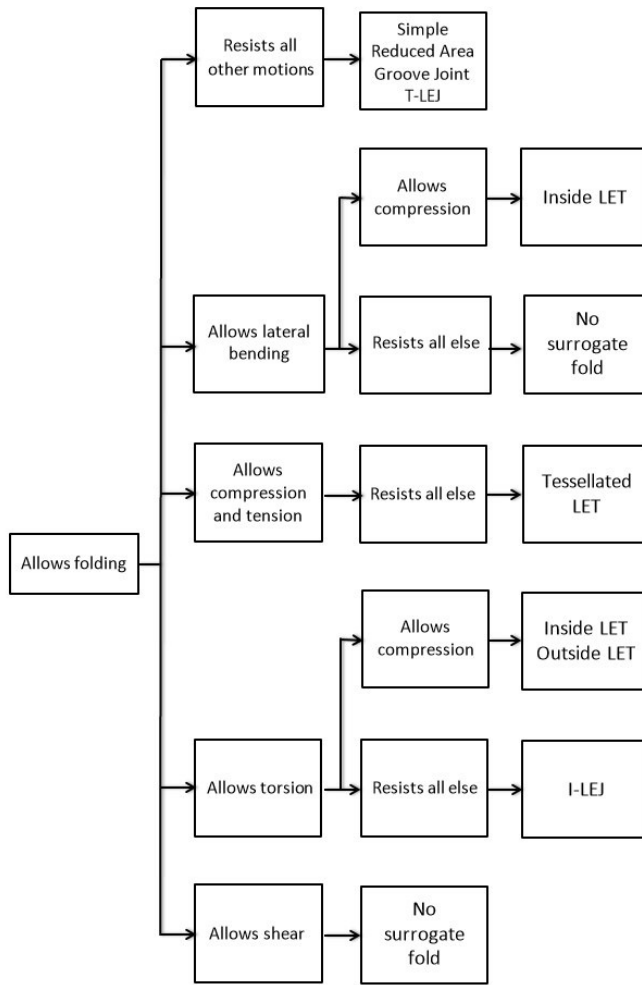

Figure 2.1: Guide for the selection of surrogate folds. All surrogate folds presented are flexible in folding. If another motion is desired, it is selected from the second column.

applications where two-dimensional machining operation is desired (e.g. laser, plasma, water jet, and stamping)

2.4 Groove Joint

The Groove Joint (Figure 2.2) is among the simplest of surrogate folds. The non-grooved portion of the material is considered rigid. The resistance of the Groove Joint to folding when modeled as a simple rectangular beam for small deflections is expressed by:

$$\frac{\theta}{F} = \frac{L^2}{2EI} \quad I = \frac{WH^3}{12} \quad (2.1)$$

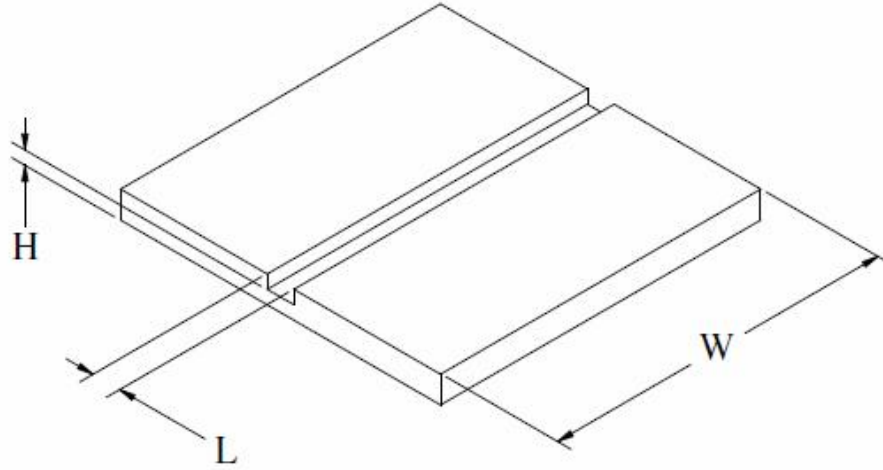

Figure 2.2: The Groove Joint with critical parameters labeled.

where θ is the angular deflection of the joint and the force acts normal to the flexible member at the end of the compliant segment. For more accurate analysis use analysis techniques capable of modelling large deflections [9, 18]. The resistance of the Groove Joint to lateral bending when modeled as a simple rectangular beam is given by:

$$\frac{\theta}{F} = \frac{L^2}{2EI} \quad I = \frac{HW^3}{12} \quad (2.2)$$

The resistance of the Groove Joint to torsion is given by:

$$\frac{\theta}{T} = \frac{1}{K_T} \quad (2.3)$$

where K_T is found using:

$$K_T = \frac{WH^3 \left(\frac{1}{3} - 0.21 \frac{H}{W} \left(1 - \frac{H^4}{12W^4} \right) \right) G}{L} \quad (2.4)$$

The resistance of the Groove Joint to tension and compression is a function of the cross sectional area, but it can be considered stiff in this direction. The groove is considered short enough to neglect buckling. The Groove Joint has a high resistance to shear compared to other surrogate folds. The center of rotation is stable compared to other monolithic surrogate folds. For a detailed

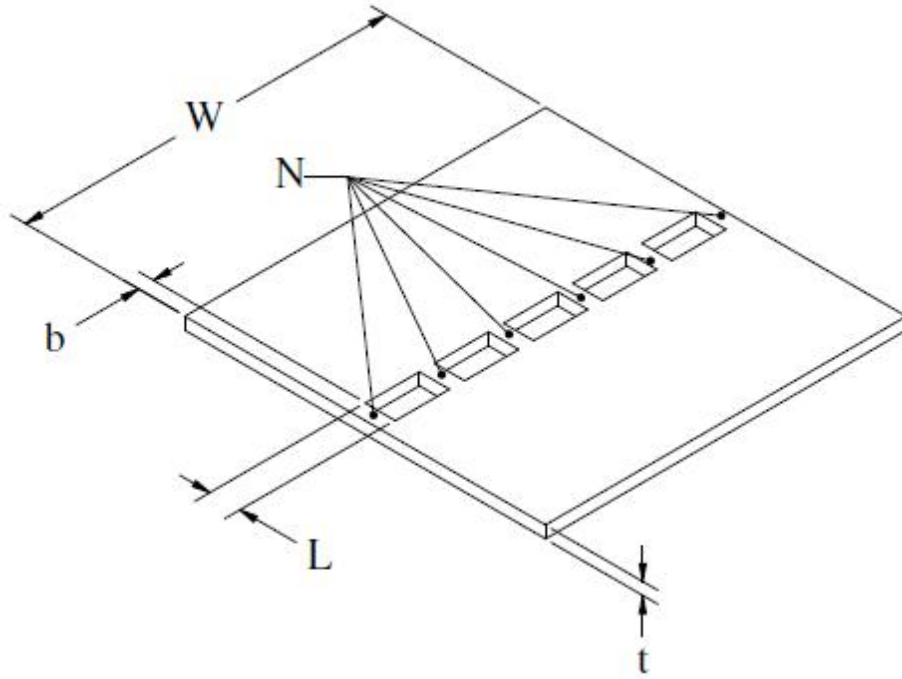

Figure 2.3: The Simple Reduced-Area Joint with critical parameters labeled.

analysis of the Groove Joints see [19]. The Groove Joint self-intersects at large deflections. The living hinge is a special case of the groove joint that offers very little resistance to deflection [9].

2.5 Simple Reduced-Area Joint

The Simple Reduced-Area Joint, illustrated in Figure 2.3, is a simple joint that is easier to model and manufacture. Because of its simplicity the Simple Reduced-Area Joint is a good alternate in surrogate fold applications.

The resistance of the Simple Reduced-Area Joint to folding with small deflections is given by:

$$\frac{\theta}{F} = \frac{NL^2}{2EI} \quad I = \frac{bt^3}{12} \quad (2.5)$$

for small deflections. For large deflections or large values of L the Pseudo-Rigid-Body Model is recommended [9]. The resistance of the Simple Reduced-Area Joint to lateral bending is approxi-

mated by multiplying the resistance of the rigid section by the ratio of the reduced area to the total cross sectional area. This gives:

$$\frac{\theta}{F} = \frac{NbL^2}{2WEI} \quad I = \frac{tb^3}{12} \quad (2.6)$$

The resistance of the Simple Reduced-Area Joint to tension and compression is a function of the cross sectional area. Buckling is neglected.

$$\frac{\delta}{F} = \frac{L}{NtbE} \quad (2.7)$$

The displacement of the Simple Reduced-Area Joint in shear is given by:

$$\delta = \gamma L \sin\left(\frac{FL^2}{4N\gamma K_{\theta} EI}\right) \quad I = \frac{tb^3}{12} \quad (2.8)$$

where γ and K_{θ} are often approximated as $\gamma = 0.85$ and $K_{\theta} = 2.65$ [9]. The Simple Reduced-Area Joint is relatively stiff in torsion. The center of rotation is stable when compared with other monolithic surrogate folds. It is difficult to achieve large deflections using the Simple Reduced-Area Joint.

2.6 Outside LET

The Outside Laminar Emergent Torsional joint (LET), illustrated in Figure 2.4, is suited for applications where large angles of rotation are necessary. The ability to manufacture the Outside LET in two dimensions allows it to be manufactured at a lower cost than some other surrogate folds.

Figure 2.5 shows a simplified model of the resistance of the Outside LET Joint to movement in the folding direction. While these resistances are most accurately modelled as torsional springs, Figure 2.5 shows these resistances as linear springs to better show the equivalent spring resistance. This resistance is given by:

$$\frac{\theta}{T} = \frac{1}{K_{eq}} \quad (2.9)$$

Jacobsen [12] gives the equivalent resistance of the Outside LET joint to folding as:

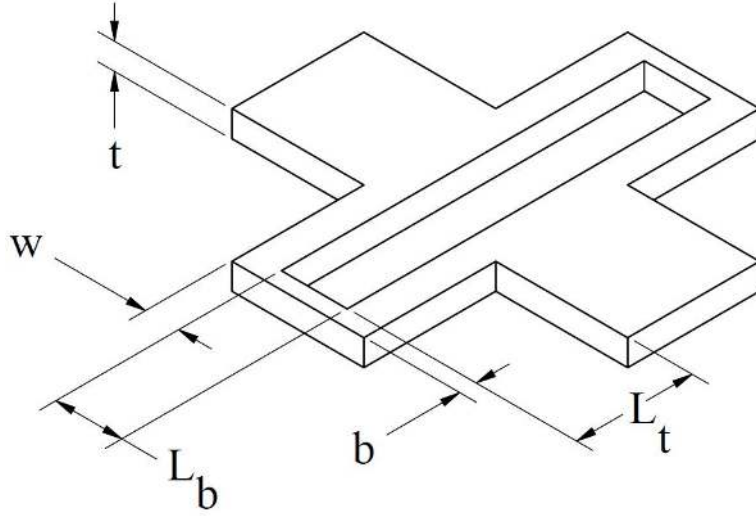

Figure 2.4: The Outside LET Joint with critical parameters labeled.

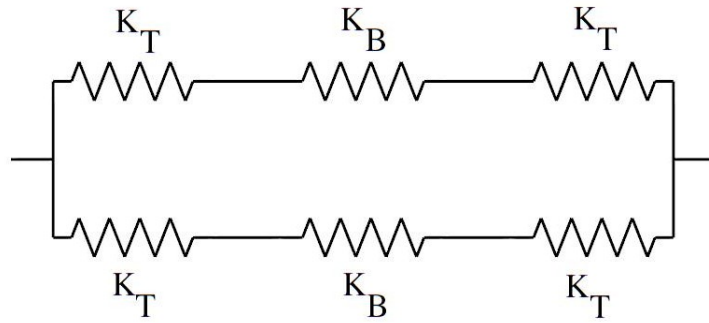

Figure 2.5: Equivalent spring diagram for Outside LET in folding. K_B and K_T are torsional spring constants shown as linear for ease of visualization.

$$K_{eq} = \frac{2K_B K_T}{K_T + 2K_B} \quad (2.10)$$

The spring constant of each of the torsion legs of the LET is given by:

$$K_T = \frac{wt^3(\frac{1}{3} - 0.21\frac{t}{w}(1 - \frac{t^4}{12w^4}))G}{L_T} \quad (2.11)$$

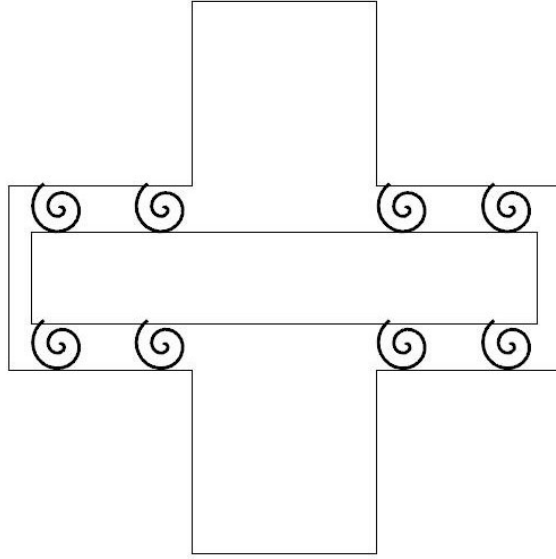

Figure 2.6: Spring diagram for Outside LET in tension and compression. Each torsional spring has a stiffness of K_{fg} as defined by Equation (2.13).

where $w \geq t$ and G is the shear modulus. The spring constant of the bending portions of the Outside LET is given by:

$$K_B = \frac{EI}{L_B} \quad I = \frac{bt^3}{12} \quad (2.12)$$

The LET Joint is particularly susceptible to parasitic motion in compression and tension [12]. The spring constant of any spring shown in Figure 2.6 is given by:

$$K_{fg} = 2\gamma K_\theta \frac{EI}{L_t} \quad I = \frac{tw^3}{12} \quad (2.13)$$

where γ and K_θ are often approximated as $\gamma = 0.85$ and $K_\theta = 2.65$ [9]. The force applied to the joint in compression or tension is related to the total deflection of the joint by the following equation:

$$F = 4K_{fg} \frac{\alpha}{\cos(\alpha)} \quad \alpha = \sin^{-1} \left(\frac{d}{2\gamma L_t} \right) \quad (2.14)$$

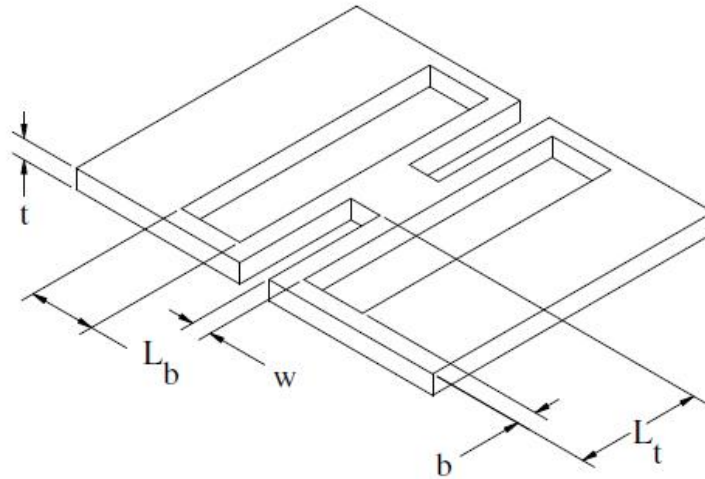

Figure 2.7: The Inside LET with critical parameters labeled.

where F is the tensile or compressive force applied to the joint and d is the distance deflected. The Outside LET joint is relatively flexible in torsion, shear, and lateral bending. The Outside LET has an unstable center of rotation.

2.7 Inside LET

The Inside LET Joint [12], illustrated in Figure 2.7, exhibits many of the properties of the Outside LET, but can have increased stiffness in tension and compression. The Inside LET Joint also behaves differently in folding. The equivalent spring constant can be found using:

$$K_{eq} = \frac{K_B K_T}{K_T + K_B} \quad (2.15)$$

where K_B and K_T are the equivalent spring constants of the bending and torsion members as shown in Figure 2.8. K_B and K_T are given by Equations (2.11) and (2.12).

The displacement for the Inside LET Joint in compression is the same as for the Outside LET Joint for small deflections as defined by Equations (2.13) and (2.14). For large deflections, the Inside LET is stiffer than the Outside LET since the torsion members are not truly fixed-guided. At large deflections they are placed in tension, changing the motion of the joint.

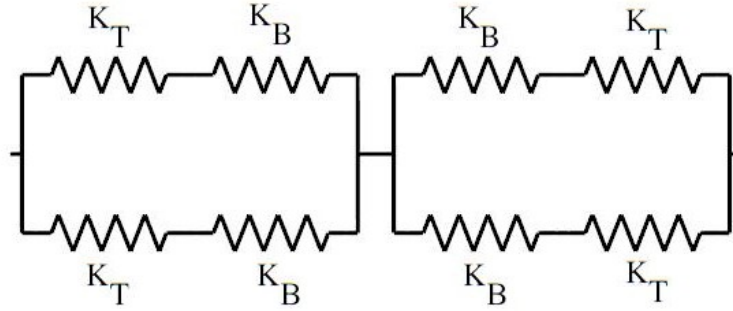

Figure 2.8: The spring diagram for the Inside LET in folding.

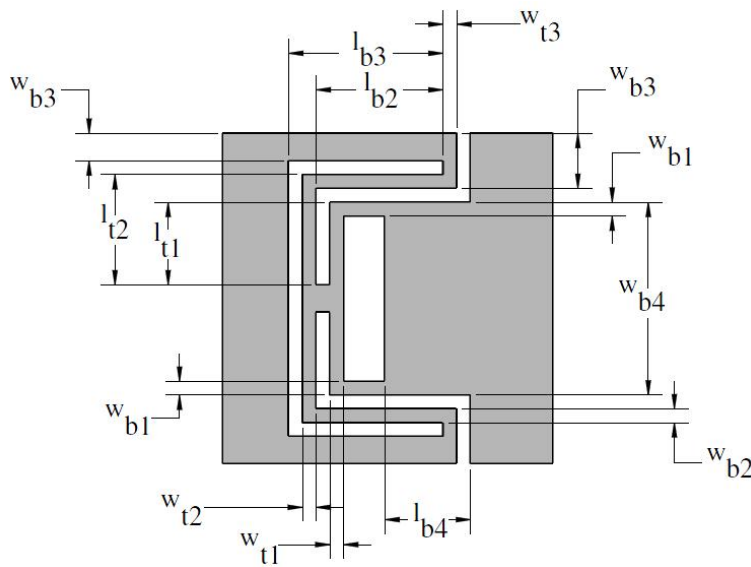

Figure 2.9: The Inverted Lamina Emergent Joint (I-LEJ) with critical parameters labeled.

The Inside LET Joint has an unstable center of rotation. In addition, the two dimensional geometry lends itself to quick, cost-effective manufacture.

2.8 Inverted Lamina Emergent Joint

The Inverted Lamina Emergent Joint (I-LEJ) is designed to reduce the parasitic motion of the LET joint in compression [20]. The long bending members in this joint provide most of the movement, although some torsion is present in the torsion members. The equivalent stiffness of the I-LEJ in folding is given by:

$$K_{eq} = \frac{2K_{b1}K_{b2}K_{b3}K_{b4}K_{t1}K_{t2}K_{t3}}{K_{sum}K_{b4} + 2K_{b1}K_{b2}K_{b3}K_{t1}K_{t2}K_{t3}} \quad (2.16)$$

where

$$\begin{aligned} K_{sum} &= K_{b1}K_{b2}K_{b3}K_{t1}K_{t3} + K_{b1}K_{b2}K_{b3}K_{t2}K_{t3} \\ &+ K_{b1}K_{b2}K_{b3}K_{t1}K_{t3} + K_{b1}K_{b3}K_{t1}K_{t2}K_{t3} \\ &+ K_{b1}K_{b2}K_{b3}K_{t1}K_{t2} + K_{b1}K_{b2}K_{t1}K_{t2}K_{t3} \end{aligned} \quad (2.17)$$

and

$$K_{b1} = \frac{w_{b1}t^3E}{12l_{b1}} \quad (2.18)$$

$$K_{b2} = \frac{w_{b2}t^3E}{12l_{b2}} \quad (2.19)$$

$$K_{b3} = \frac{w_{b3}t^3E}{12l_{b3}} \quad (2.20)$$

$$K_{b4} = \frac{w_{b4}t^3E}{12l_{b4}} \quad (2.21)$$

$$K_{t1} = w_{t1}t^3 \frac{G}{l_{t1}} \left[\frac{1}{3} - 0.21 \frac{t}{w_{t1}} \left(1 - \frac{t^4}{12w_{t1}^4} \right) \right] \quad (2.22)$$

$$K_{t2} = w_{t2}t^3 \frac{G}{l_{t2}} \left[\frac{1}{3} - 0.21 \frac{t}{w_{t2}} \left(1 - \frac{t^4}{12w_{t2}^4} \right) \right] \quad (2.23)$$

$$K_{t3} = w_{t3}t^3 \frac{G}{l_{t3}} \left[\frac{1}{3} - 0.21 \frac{t}{w_{t3}} \left(1 - \frac{t^4}{12w_{t3}^4} \right) \right] \quad (2.24)$$

The I-LEJ can be made for either high or low resistance to torsion depending on the value of $w_{b4} - 2w_{b1} - 2l_{tl}$. The resistance of the I-LEJ to compression is higher than the LET joint. The I-LEJ can be used in large deflection applications without self-intersecting. The center of rotation is unstable.

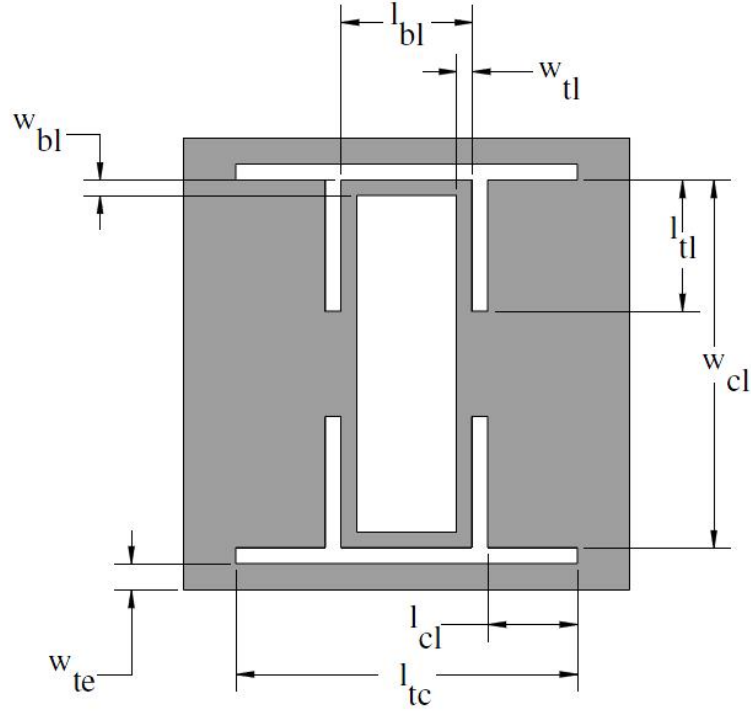

Figure 2.10: The Tension Lamina Emergent Joint (T-LEJ) with critical parameters labeled.

2.9 Tension Lamina Emergent Joint

The Tension Lamina Emergent Joint (T-LEJ), shown in Figure 2.10, provides the motion of the LET joints while increasing the resistance of the joint to tension [20]. The equivalent stiffness of the joint in folding is

$$K_{eq} = \frac{2K_{bl}K_{tl}K_{cl}}{4K_{bl}K_{tl} + K_{cl}(2K_{bl} + K_{tl})} + 2K_{te} \quad (2.25)$$

where

$$K_{bl} = \frac{Ew_{bl}t^3}{12l_{bl}} \quad (2.26)$$

$$K_{tl} = w_{tl}t^3 \frac{G}{l_{tl}} \left[\frac{1}{3} - 0.21 \frac{t}{w_{tl}} \left(1 - \frac{t^4}{12w_{tl}^4} \right) \right] \quad (2.27)$$

and

$$K_{cl} = \frac{Ew_{cl}t^3}{12l_{cl}} \quad (2.28)$$

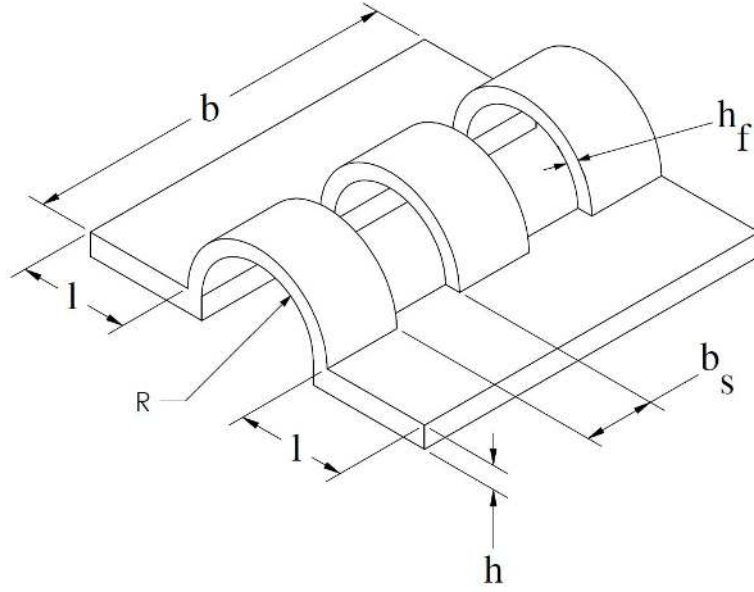

Figure 2.11: The Revolute U-form Flexure (RUFF) with critical parameters labeled.

$$K_{te} = \frac{Ew_{te}t^3}{12l_{te}} \quad (2.29)$$

The stiffness of the T-LEJ in tension is expressed by:

$$K_{eq} = \frac{K_{cl,a}K_{tl,a}}{2K_{tl,a} + K_{cl,a}} + 2K_{te,a} \quad (2.30)$$

where

$$K_{cl,a} = \frac{w_{cl}tE}{l_{cl}} \quad (2.31)$$

$$K_{tl,a} = \frac{Etw_{tl}^3}{l_{tl}^3} \quad (2.32)$$

$$K_{te,a} = \frac{w_{te}tE}{l_{te}} \quad (2.33)$$

The center of rotation for the T-LEJ is unstable when loaded in any condition other than pure folding. The T-LEJ can produce large deflections without self-intersecting. Additionally, the T-LEJ has a larger resistance to torsion than the Outside LET.



Figure 2.12: The Torsional U-form Flexure.

2.10 Revolute U-form Flexure

The Revolute U-form Flexure (Figure 2.11) is a unique surrogate fold ideally suited for use in sheet metal applications [21]. The resistance of the hinge to folding is given by:

$$y_{max} = \frac{F^2}{4EI_c}(2\pi l^2 + 4\pi lR + 3\pi R^2) + \frac{FL}{3EI_s}(4l^2 + 9lR + 6R^2) \quad (2.34)$$

where the force (F) is applied at the edge of the joint. I_c and I_s are given by:

$$I_s = \frac{bh^3}{12} \quad (2.35)$$

$$I_c = \frac{(b - Nb_s)h_f^3}{12} \quad (2.36)$$

where N is the number of slots (I.E., $N = 2$ in Figure 2.11). The RUFF joint's center of rotation is unstable. Typically the RUFF is used for relatively small deflections. It is flexible in torsion.

2.11 Torsional U-form Flexure

The Torsional U-form Flexure (TUFF) [21], illustrated in Figure 2.12, is designed to increase the torsional stiffness of the RUFF joint. For an analysis of the TUFF joint refer to [21]. The torsional joint is suited for use in metal applications.

2.12 Conclusions

While the development and presentation of the closed-form solutions for the various surrogate folds provides a reference for product designers wishing to employ origami-inspired design, it also highlights several areas for which new surrogate folds could be developed. Table 2.1 references the equations governing the motion of the monolithic surrogate folds. Table 2.2 shows the deflected shape of each surrogate fold in its more flexible motions. Surrogate folds with predictable torsion, shear, and lateral bending equations are few.

Table 2.1: Equations describing surrogate fold motion.

	Folding	Torsion	Lateral Bending	Shear	Compression/Tension
Groove Joint	1	3 - 4	2		
Simple Reduced Area	5		6	8	7
Outside LET	9 - 12				13 - 14
Inside LET	9,11, 12,15				13 - 14
I-LEJ	16 - 24				
T-LEJ	25 - 29				30 - 33
RUFF	34 - 36				

For some applications, such as deployable solar arrays, some shear motion is desirable [1]. While some of the surrogate folds presented in this paper allow some motion in shear, none of these motions have been quantified.























Many of the torsional joints are particularly flexible in tension and compression. A joint that allowed the folding motion of the LET joints but that had a higher stiffness in compression would be useful. Although the I-LEJ and T-LEJ provide improved stiffness in tension and compression, their complex geometries make closed-form solutions difficult. In addition, these two joints require a larger area than LET joints.

None of the existing surrogate folds considered allow lateral bending while still maintaining a high resistance to the other motions. A joint with a low resistance to both folding and lateral bending would give a motion not allowed by any of the studied surrogate folds.

Joints with a stable center of rotation are notably lacking. Unstable centers of rotation render the surrogate fold unsuitable for high or moderate precision applications. Development of higher stability surrogate folds would allow designers to more accurately model the motion of the joint.

These deficiencies in existing surrogate folds leaves room for improvement and development of new surrogate folds that will provide designers with more versatile options for origami-inspired designs.

Table 2.2: Surrogate folds and their secondary motions. For the five motions grey boxes indicate high stiffness resisting that motion. For large deflections grey indicates the surrogate fold is capable of undergoing large deflections. For stable center of rotation grey indicates the surrogate fold has a relatively stable center of rotation.

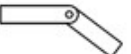
	Groove Joint 	Simple Reduced Area 	Outside LET 	Inside LET 	I-LEJ 	T-LEJ 
Torsion 						
Lateral Bending 						
Shear 						
Compression 						
Tension 						
Large Deflections 	Small deflections	Small deflections				
Stable Center of Rotation 			Unstable	Unstable	Unstable	Unstable

CHAPTER 3. A FAMILY OF DUAL-SEGMENT COMPLIANT JOINTS SUITABLE AS SURROGATE FOLDS

3.1 Introduction

Origami, the ancient art of paper folding, can provide inspiration for the design of new and novel mechanical systems. Origami-inspired designs are capable of producing three dimensional objects from a two dimensional sheet using a single fabrication process [6].

When challenging design constraints are present, origami-inspired designs can provide novel solutions. Examples include deployable solar arrays for satellite applications [22], medical stents [2], car crash boxes with high crumple zone energy dissipation [3], deployable sterile shrouds for medical applications [23], structural cores for aerospace applications which mitigate water retention in the sandwiched layers [4], airbag folding, and the 100 meter diameter Eyeglass telescope [5]. In many of these instances the thickness of the material is greater than that of paper and requires a specialized hinge acting in place of a fold.

Origami can be analyzed as mechanisms where panels are considered rigid bodies and folds are treated as joints [6–8]. A fold can be defined as a decrease in stiffness along the fold axis. In paper, this reduction in stiffness is achieved through a localized reduction in thickness and delamination, which changes the properties. Non-paper sheet materials do not manifest this behavior [24]. A surrogate fold is a localized reduction in stiffness achieved through geometry to allow non-paper materials to achieve similar behaviors to a fold in paper. The object of a surrogate fold is to provide a fold-like motion in a non-paper material without undergoing yielding. Compliant mechanism approaches provide a means to achieve this objective.

To achieve paper-like deflections in non-paper materials it is helpful to have a systematic approach for creating and selecting compliant systems suitable for use in origami-inspired designs. The dual-segment joint consists of two rigid segments separated by two symmetric compliant flexures, such as shown in Figure 3.1. The pseudo-rigid body equivalent of a surrogate fold is shown

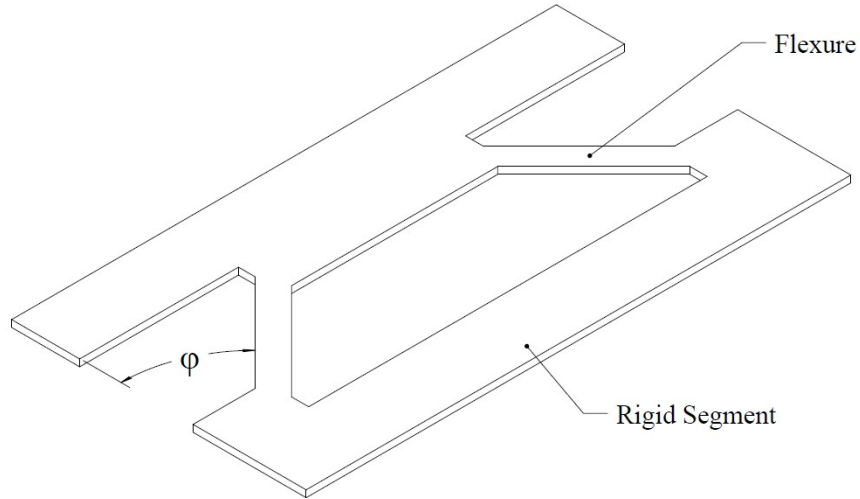

Figure 3.1: The parameter ϕ affects the response of the surrogate fold to tension and compression.

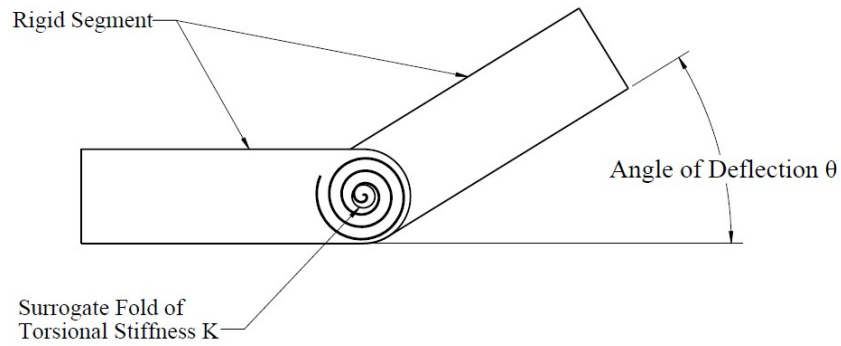

Figure 3.2: The pseudo-rigid body equivalent of a surrogate fold.

in Figure 3.2 [9, 25]. The objective of this paper is to provide a systematic approach for the use of the dual-segment joint as a surrogate fold.

3.2 Background

Previous work has developed several surrogate folds using compliant mechanism concepts [26]. However, some vacancies in the design space exist. These vacancies provide opportunity for new developments into surrogate folds in origami-inspired design. Six motions have been identified to guide the development of new surrogate folds. These motions are shown in

Figure 1.1. It is assumed that folding, the motion shown in Figure 1.1a, is always desirable in a surrogate fold. Depending on the application, the other five motions may be parasitic or undesirable. In some design situations, folding and another motion are desirable. For example, for some deployable solar arrays, motion in shear is desirable [1]. Some deployable origami-inspired mechanisms required flexible linkages [27] or surrogate folds allowing secondary motion. When closed-form solutions are developed for these motions the designer is able to accurately predict the response of the surrogate fold.

Many existing surrogate folds rely on compliant segments which undergo torsion to achieve deflection in the folding direction. This class of compliant joints, called torsional joints, are particularly flexible in tension and compression. A joint that allowed the folding motion of the torsional joints, such as the Lamina Emergent Torsional Joint (LET) [12], but that had a higher stiffness in compression would be useful. Although the I-LEJ and T-LEJ [20] provide improved stiffness in tension and compression, their complex geometries make closed-form solutions difficult. In addition, these two joints require a larger footprint than standard LET joints. In general the size of the joint away from the axis of the fold is more critical than size along the axis of the fold. In this direction the I-LEJ and T-LEJ are large.

Few existing surrogate folds allow lateral bending while still maintaining a high resistance to the other motions [26]. A joint with a low resistance to both folding and lateral bending would give a motion not easily achieved with existing surrogate folds.

These deficiencies in existing surrogate folds leave room for improvement of existing joints and development of new joints. The family of new joints presented in this paper provide designers with more versatile options for origami-inspired designs.

3.3 A Continuum of Dual-Segment Compliant Joints

A systematic approach to modelling of a dual-segment joint is valuable in the design of compliant joints suitable for surrogate folds. A systematic approach for varying the response of a surrogate fold is to vary the angle of the compliant segments. This angle, labelled as ϕ in Figure 3.1, affects the stiffness of the joint to the motions seen in Figure 1.1.

Table 3.1 shows various compliant joints suitable for use as surrogate folds as ϕ varies from 0 to 180°. Values of ϕ between 0 and 90° will have a higher resistance to tension than compression.

Table 3.1: Geometries and responses of compliant joints as ϕ changes. Columns four, five, and six list the loading condition of the compliant members when the joint is loaded as indicated in the column heading.

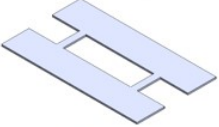
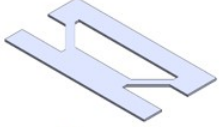
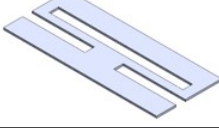
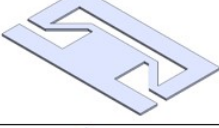
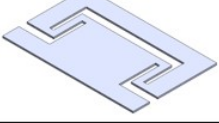
Name	ϕ	Geometry	Flexural Loading when dual-segment joint in		
			Folding	Tension	Compression
Bending-Orthogonal	0		Bending	Tension	Compression
Mixed Tension Resistant	0-90		Mixed Torsion, Bending, and Tension	Mixed Tension and Bending	Mixed Compression and Bending
Torsion-Parallel	90		Torsion	Fixed-Clamped Bending	Fixed-Clamped Bending
Mixed Compression Resistant	90-180		Mixed Torsion, Bending, and Tension	Mixed compression and bending	Mixed tension and bending
Inverted Bending-Orthogonal	180		Bending	Compression	Tension

For values of ϕ between 90 and 180° the compliant joint has a higher resistance to compression than tension. By varying this parameter the designer can customize the performance of the joint. The special cases of the dual-segment joint as ϕ varies and their allowable secondary motions are listed in Figure 3.16. The properties of dual-segment joints for five ranges of ϕ are considered. In all analysis, non-compliant segments are considered rigid.

As ϕ varies, the stiffness of the dual-segment joint can change. The resistance of the dual-segment joint in folding when ϕ is equal to zero is given using the Pseudo-Rigid-Body Model [9]. This value is a torsional spring constant relating the angle of deflection to the actuating torque.

$$K_B = \frac{T}{\theta} = \frac{2CEI}{L} \quad I = \frac{wt^3}{12} \quad (3.1)$$

where w is the width, t is the thickness, and L is the length of the compliant segment, E is the Young's modulus, and C is often approximated as 1.5164.

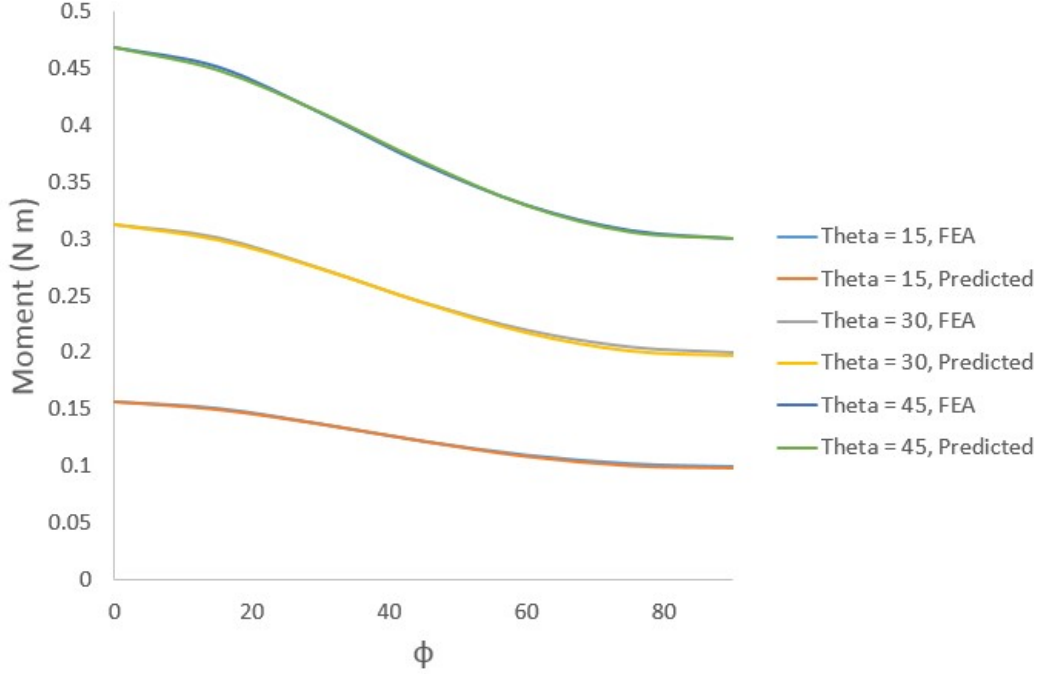

Figure 3.3: Comparison of Equation (3.3) and FEA results for varying values of ϕ from 0 to 90 degrees. The compliant members of the joint have a length of $L = 5$ cm, $w = 0.4$ cm, and $t = 0.4$ cm, $E = 1.4$ GPa, and $\nu = 0.34$.

When ϕ is equal to 90° the stiffness of the compliant joint in the folding motion is given by [28]:

$$K_T = \frac{2wt^3 \left(\frac{1}{3} - 0.21 \frac{t}{w} \left(1 - \frac{t^4}{12w^4} \right) \right) G}{L} \quad (3.2)$$

where w is the width of the compliant segment, t is the thickness, G is the shear modulus, and $w \geq t$.

For all values of ϕ between 0 and 180° the stiffness of the dual-segment joint is

$$K_{mixed} = \left| 1 - \frac{2\phi}{\pi} \right|^{0.1096} K_B \cos^2 \phi + K_T \sin^2 \phi \quad (3.3)$$

where ϕ is the angle of the compliant arm in radians and K_B and K_T are given by Equations (3.1) and (3.2). Equation (3.3) is a curve fit based on FEA data.

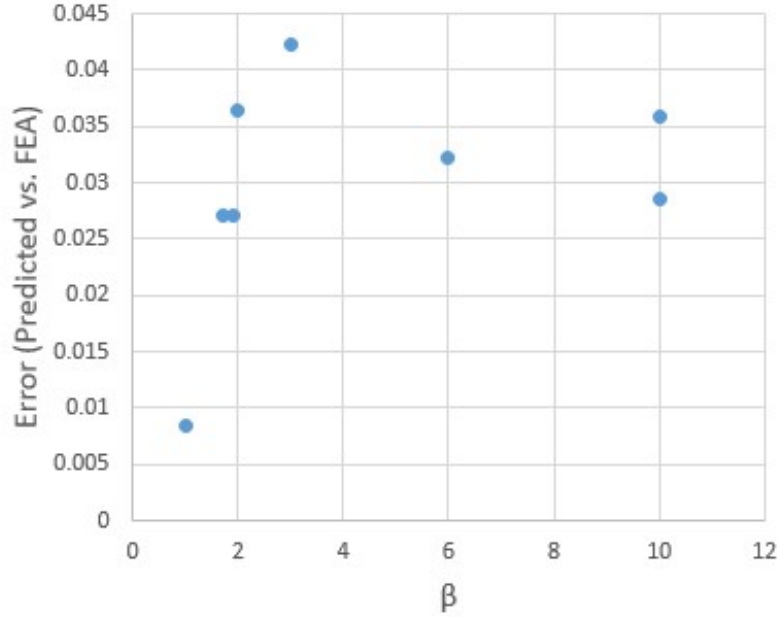

Figure 3.4: The error of Equation (3.3) vs β for a variety of cross sections and lengths.

The exponent 0.1096 in Equation (3.3) was optimized to minimize error for a length of 5 cm with width and thickness of 0.4 cm. A finite element analysis (FEA) model of the compliant joint was created using ANSYS (Beam188 elements). Predicted values are compared with the FEA results in Figure 3.3. The equation provides an approximation for the stiffness of a compliant joint for values of ϕ between 0 and 180°. The error of Equation (3.3) compared to β is shown for a few selected cross sections in Figure 3.4. Additional work in this area may be beneficial to understand the behavior of the Dual-Segment Joint. If a more accurate value is desired, FEA is recommended.

For square compliant members K_B is greater than K_T . For compliant members in which w is large compared to t , K_T is greater than K_B , as shown in Figure 3.5. The cross section which will produce K_B equal to K_T is of particular interest because for this special case the stiffness is constant for all values of ϕ .

The ratio of K_B to K_T can be found using Equations (3.1) and (3.2) as

$$\frac{K_B}{K_T} = \frac{(1 + \nu)}{2 - \frac{1.26}{\beta} \left(1 - \frac{1}{12\beta^4}\right)} \quad \beta = \frac{w}{t} \quad (3.4)$$

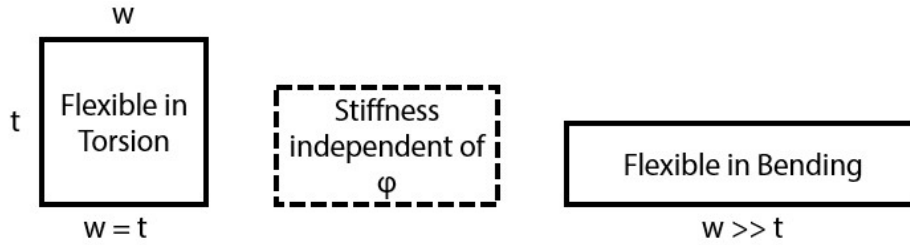

Figure 3.5: There exists some value of β such that the stiffness to actuate the dual-segment joint is independent of ϕ .

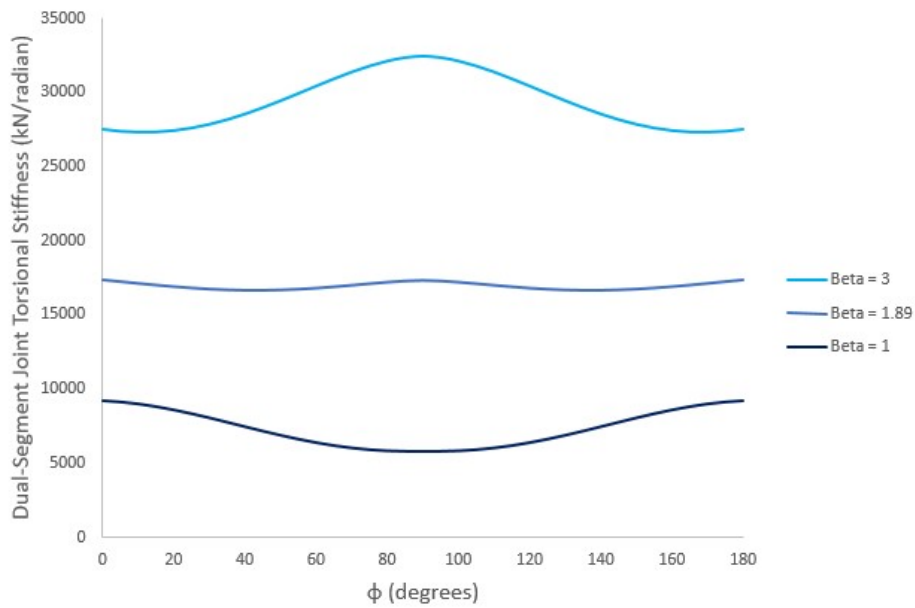

Figure 3.6: Deflection stiffness to actuate the dual-segment joint vs. the angle ϕ as given by Equation (3.3).

where ν is Poisson's ratio. When the ratio of K_B to K_T is set to one, the value of β is such that the stiffness of the compliant joint in the folding direction is constant for all angles of ϕ , as shown in Figure 3.6. This value of β is of particular use to the designer, as ϕ can be changed without varying the stiffness in folding. A desired folding stiffness can be selected, then ϕ can be varied to give the necessary resistance to tension or compression. For example, for a Poisson's ratio of 0.34, β equal to 1.89 gives a constant stiffness for all values of ϕ .

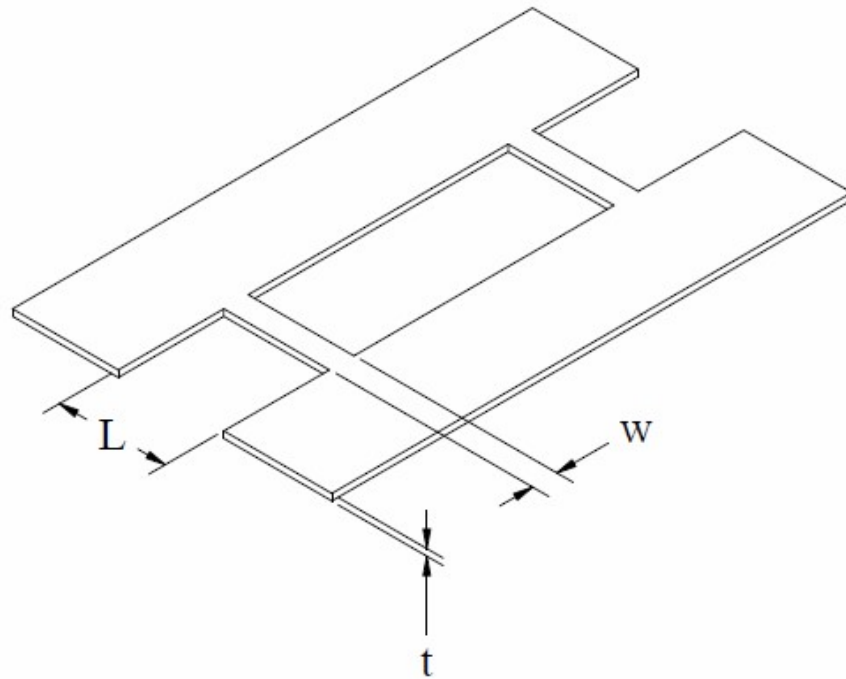

Figure 3.7: When $\phi = 0$, the dual-segment joint is called the Bending-Orthogonal Joint, also called the Simple Reduced Area Joint.

While the dual-segment joint can be used at any value of ϕ , certain ranges possess properties of interest for design purposes. The response of the compliant joint to secondary motions, such as tension and compression, is of particular interest. Special cases for various values of ϕ and the resulting properties are described next.

3.4 Bending-Orthogonal Joint ($\phi = 0^\circ$)

The Bending-Orthogonal Joint has flexure geometry running orthogonal to the joint axis and with flexures that undergo only bending when a moment is applied to actuate the joint, as shown in Figure 3.7. The Bending-Orthogonal Joint, also called the Simple Reduced Area Joint, is easily modelled and manufactured.

The resistance of the Bending-Orthogonal Joint to tension and compression is a function of the cross sectional area.

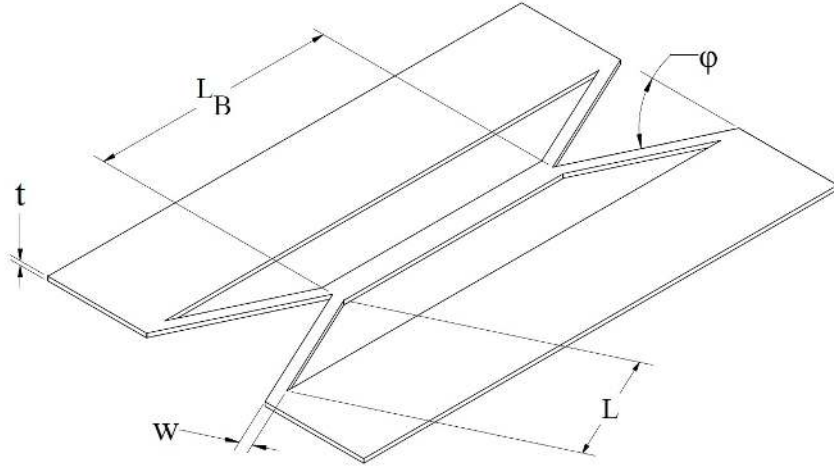

Figure 3.8: The addition of a center buckling member to the mixed tension resistant, labelled L_B , decreases the force required to actuate the joint in compression.

$$\frac{F}{\delta} = \frac{2twE}{L} \quad (3.5)$$

In compression, buckling should also be considered. The Bending-Orthogonal Joint is relatively flexible in the shear direction. The resistance of the Bending-Orthogonal Joint to shear is given by

$$\delta = \gamma L \sin\left(\frac{FL^2}{2N\gamma K_{\Theta} EI}\right) \quad I = \frac{tw^3}{12} \quad (3.6)$$

where γ and K_{Θ} are often approximated as $\gamma = 0.85$ and $K_{\Theta} = 2.65$ [9] and N is equal to the number of compliant legs ($N = 2$ for dual segment joints such as shown in Figure 3.7).

3.5 Mixed Tension Resistant Joint ($\phi = 0-90^\circ$)

In some applications a surrogate fold with stiffer resistance to tension than compression is desired. For these applications, the Mixed Tension Resistant Joint (shown in Figure 3.1) is useful. When placed in tension, the compliant joint is stiff. When placed in compression, the compliant members of the joint buckle under relatively small loads. When an increased joint flexibility is desired for the compression direction, a center buckling member can be added (shown in Figure 3.8).

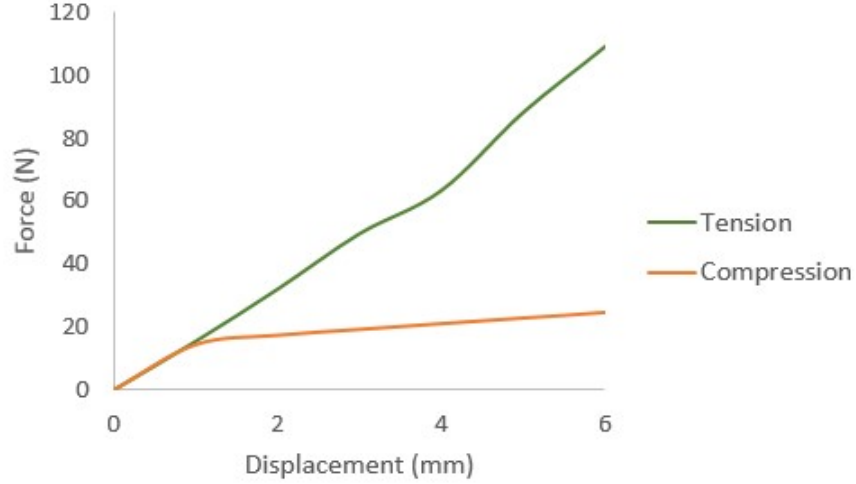

Figure 3.9: The actuation force vs. deflection for the Mixed Tension Resistant Joint in tension and compression. $\phi = 25^\circ$, $L_t = 38.07$ mm, $w = 3.18$ mm, $t = 3.43$ mm, $E = 1.37$ GPa.

This increases the overall length of the buckling element, reducing the force required to induce buckling.

Figure 3.9 shows force-deflection results for finite element analysis of the Mixed Tension Resistant Joint in tension and compression. The FEA was performed using an imported solid meshed with Solid185 elements in ANSYS.

The resistance of a single compliant member of the Mixed Tension Resistant Joint to tension can be approximated as

$$F_y = \frac{K_A (L_{def} - \gamma L) (\delta + L\gamma \cos\phi)}{L_{def}} + \frac{2K_{fg}\gamma L \left[\phi - \sin^{-1} \left(\frac{L\gamma \sin\phi}{L_{def}} \right) \right] \sin\phi}{L_{def}^2} \quad (3.7)$$

where ϕ is in radians. For more accurate results FEA is recommended. Equation 3.7 was derived by use of the Pseudo-Rigid-Body Model. The system was treated as two torsional springs, such as used to model a fixed-guided system [9], and a linear spring to account for the change in length of the compliant element. These springs are coupled through geometric terms. K_A is given by the following equation:

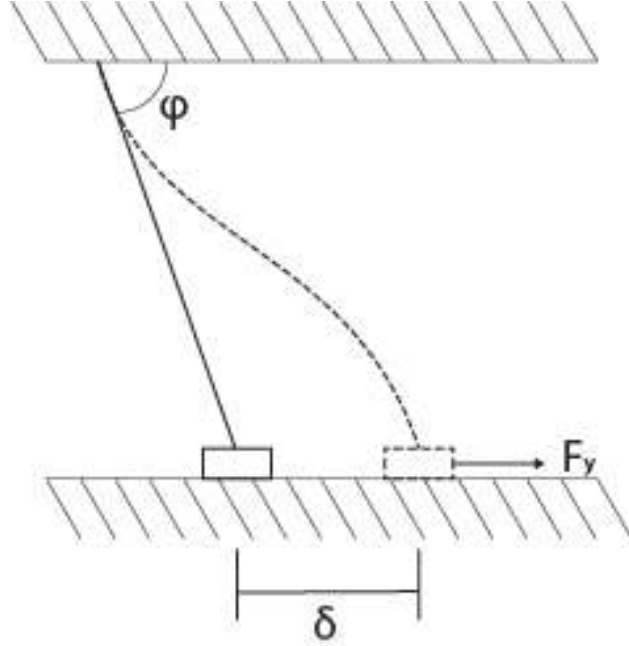

Figure 3.10: An illustration of the boundary conditions used to derive Equation (3.7).

$$K_A = \frac{Ewt \left(1 - \nu \frac{\Delta L}{\gamma L}\right)^2}{\Delta L + \gamma L} \quad (3.8)$$

based on the assumption that the cross section maintains a constant ratio of $\frac{w}{t}$ as the length changes.

K_{fg} is given by:

$$K_{fg} = \frac{2\gamma K_{\Theta} EI}{L} \quad I = \frac{tw^3}{12} \quad (3.9)$$

where E is the modulus. γ and K_{Θ} are often approximated as 0.85 and 2.65 [9]. The deflected length is given by:

$$L_{def} = \Delta L + \gamma L = \sqrt{(\gamma L)^2 + \delta^2} + 2\gamma L \delta \cos\phi \quad (3.10)$$

Buckling should be analyzed when the joint is in compression. The boundary conditions used to derive these equations are shown in Figure 3.10.

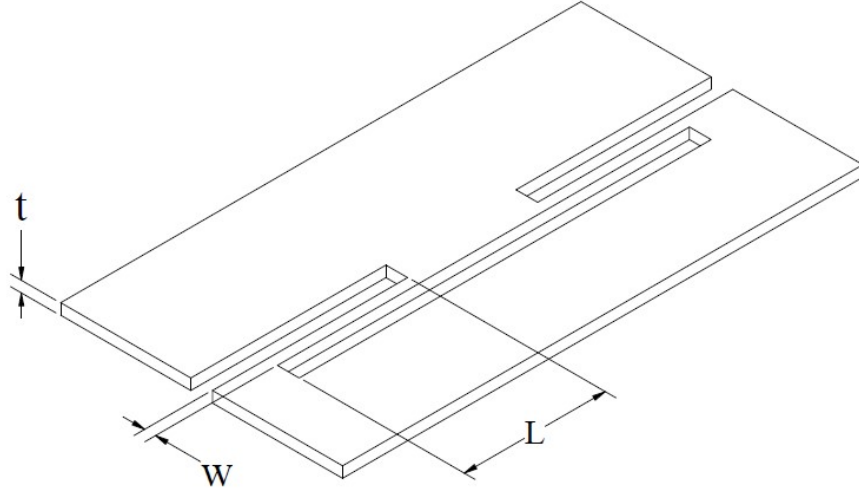

Figure 3.11: The Torsion-Parallel Joint is a specialized case of the dual-segment joint when ϕ is equal to 90° .

3.6 Torsion-Parallel Joint ($\phi = 90^\circ$)

The Torsion-Parallel Joint, shown in Figure 3.11, is a joint with flexures running parallel to the joint axis which undergo only torsion when a moment is applied to actuate the joint. While the LET Joints [12] give a useful motion in folding they have two major challenges. First, they lack fixed centers of rotation, making them difficult to use in precision situations. Second, they are vulnerable to parasitic motion in tension and compression.

The Torsion-Parallel Joint provides a more fixed center of rotation and increased stiffness in tension and compression when compared to the Outside or Inside LET joints [12]. The resistance of the Torsion-Parallel Joint to folding is given by Equation (3.2).

The Torsion-Parallel Joint is stiffer than the Outside or Inside LET joints in tension and compression. The Outside LET Joint is modelled as a fixed-guided compliant member, while the Torsion-Parallel is a fixed-clamped system. This means the stiffness in tension and compression will be increased when compared to the Outside LET. The force required to displace a single leg of the joint a distance δ is given by [29]:

$$F_y = \frac{K_A \Delta L \delta}{\Delta L + \gamma L} + \frac{2K_{fg} \gamma L \tan^{-1} \left(\frac{\delta}{\gamma L} \right)}{(\Delta L + \gamma L)^2} \quad (3.11)$$

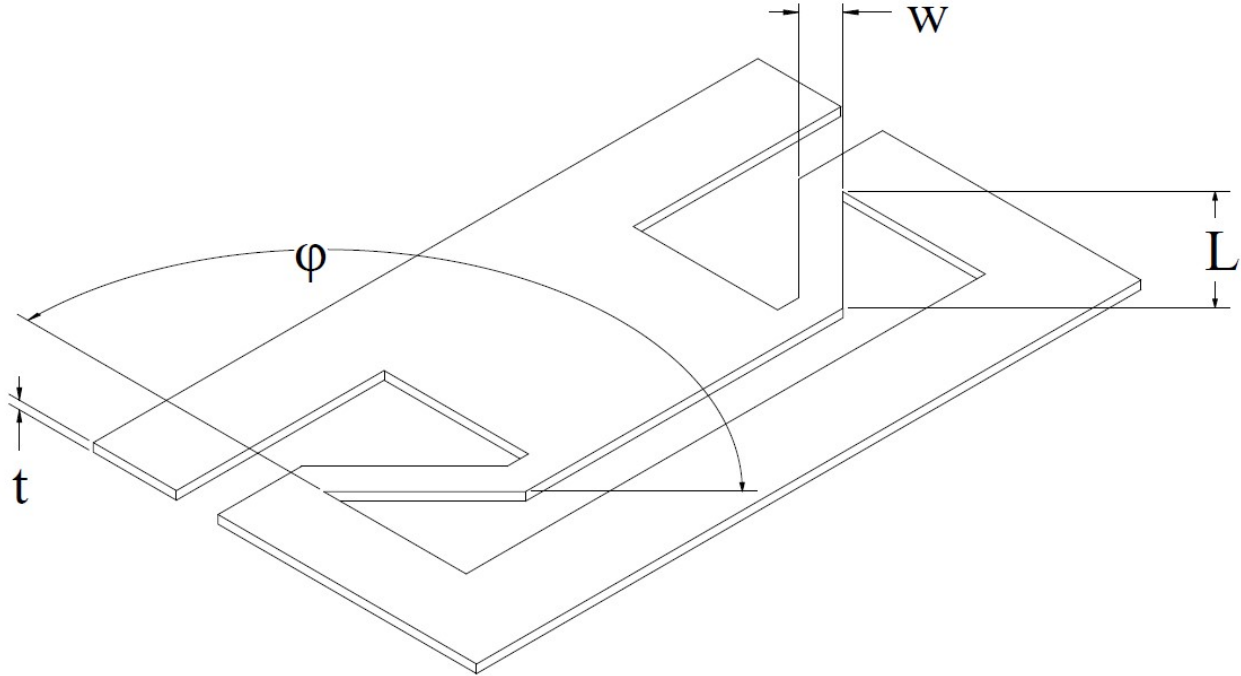

Figure 3.12: The Mixed Compression Resistant Joint gives a stiffer resistance to compression than tension.

where L is the original length of the compliant segment, γ is the characteristic radius factor often used in the Pseudo-Rigid-Body Model. K_A is given by Equation (3.8) and K_{fg} is given by Equation (3.9) and

$$\Delta L = \sqrt{\delta^2 + (\gamma L)^2} - \gamma L \tag{3.12}$$

These equations are equivalent to Equation (3.7) when ϕ is equal to 90 degrees.

3.7 Mixed Compression Resistant Joint ($\phi = 90-180^\circ$)

Most monolithic surrogate folds have equal resistance to tension and compression. Some applications exist where displacement in tension is desired, but a high resistance to compression is needed.

Figure 3.12 shows the Mixed Compression Resistant Joint, which has a high resistance to compression while remaining relatively flexible in tension. When the Mixed Compression Re-

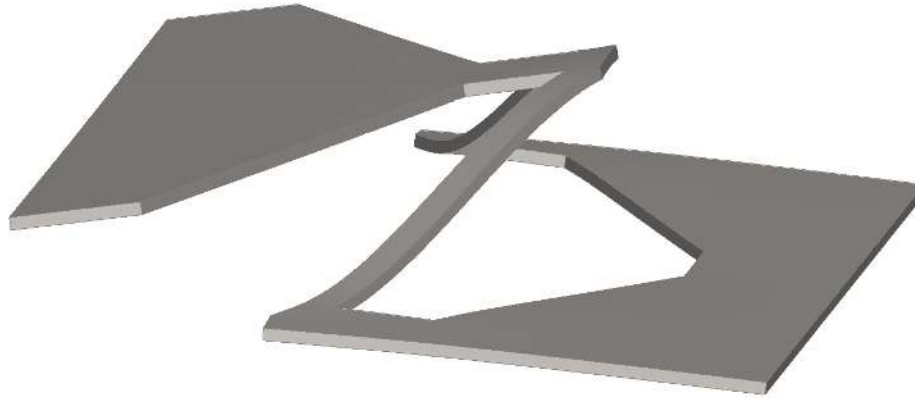

Figure 3.13: The Mixed Compression Resistant Joint rotating out of plane when placed in tension.

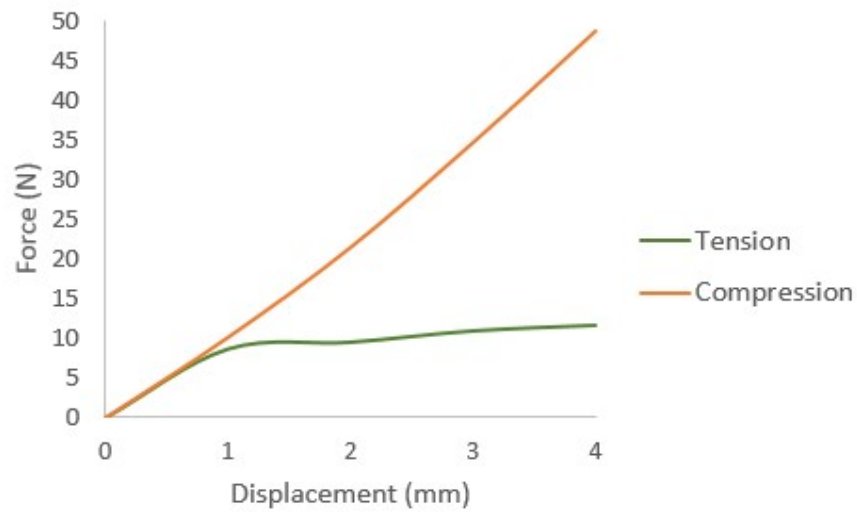

Figure 3.14: The actuation force vs. deflection for the Mixed Compression Resistant Joint in tension and compression. $\phi = 110^\circ$, $L_t = 59$ mm, $w = 3.18$ mm, $t = 1.27$ mm, $E = 1.37$ GPa.

When the compliant joint is loaded in compression the torsional members are placed in tension, giving the compliant joint a high resistance to this motion. When the compliant joint is placed in tension the torsional members rotate out of plane or buckle. An example of this out of plane rotation is shown in Figure 3.13. The response of the Mixed Compression Resistant Joint when placed in tension and compression is shown in Figure 3.14. The stiffness of the Mixed Compression Resistant Joint in compression is given by Equation (3.7) through (3.10).

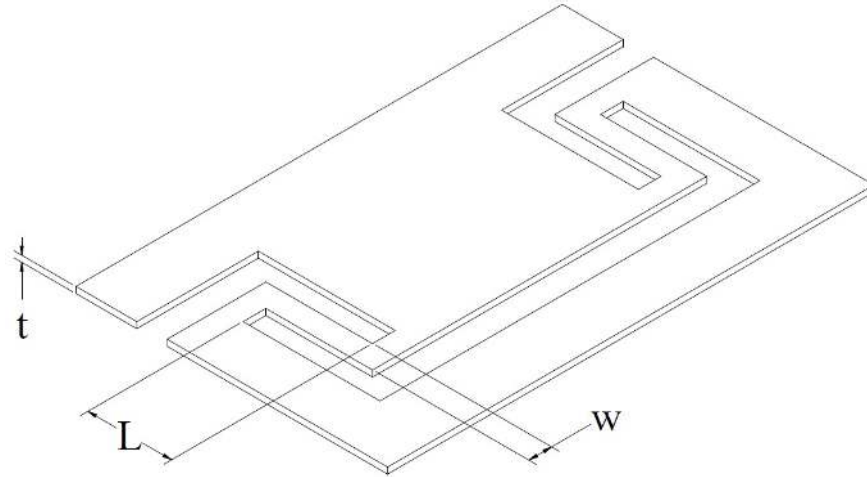

Figure 3.15: The Inverted Bending-Orthogonal Joint occurs when $\phi = 180$. The inversion causes the compliant members to be in tension when the joint is in compression. This avoids the possibility of buckling in this loading condition.

The stiffness of the Mixed Compression Resistant Joint when actuated in folding is given by Equation (3.3)

3.8 Inverted Bending-Orthogonal Joint ($\phi = 180^\circ$)

The Inverted Bending-Orthogonal Joint (shown in Figure 3.15) produces similar motion to the Bending-Orthogonal Joint. The motion of the compliant joint in bending is given by Equation (3.1).

However, when the compliant joint is placed in compression the compliant members experience tension. This eliminates the possibility of buckling when the joint is in compression. This motion is described by Equation (3.5).

The Inverted Bending-Orthogonal Joint had an identical resistance to shear as the Bending-Orthogonal Joint. This resistance is given by Equation (3.6).

3.9 Combined Compliant Joints as Surrogate Folds

When selecting a compliant joint for a given application the desired secondary motion, if any, should first be identified. Table 3.2 and Figure 3.16 show the compliant joints presented in

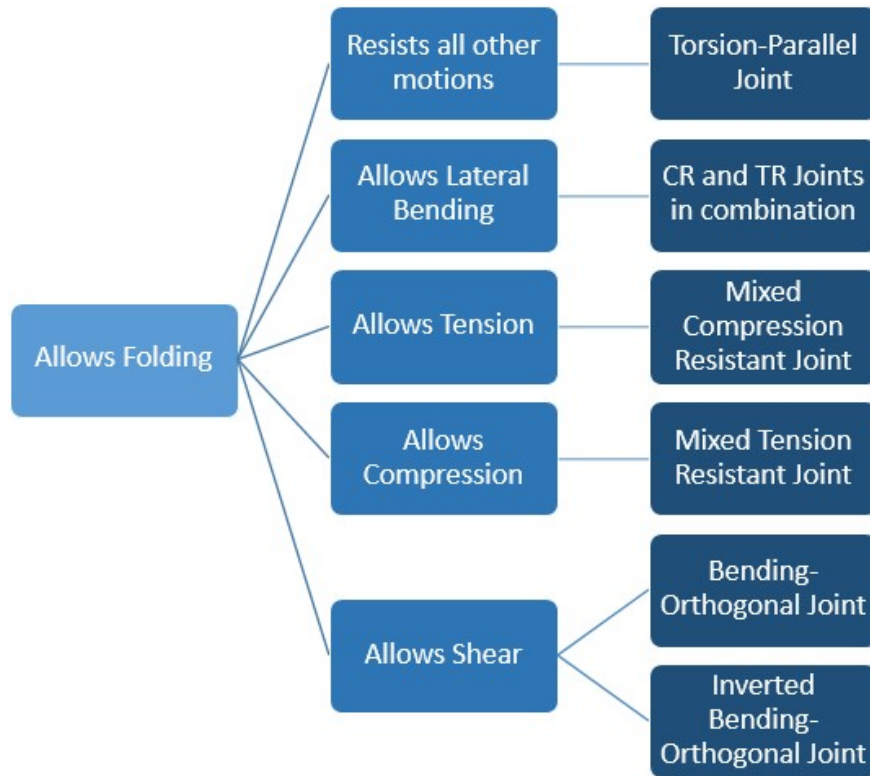







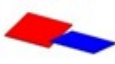

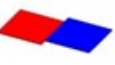







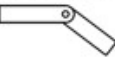

Figure 3.16: Guide for the selection of surrogate folds with dual-segment joints included.

this paper and their flexible secondary motions. If the selected compliant joint is deficient in some respect, such as unable to undergo large deflections, a modification may be explored to expand the capabilities of the compliant joint. A surrogate fold with specialized properties can often be created by combining several of the compliant joints discussed in this paper.

Several modifications can be made to change the properties of a compliant joint. When two compliant joints are combined in series the maximum deflection is doubled. However, combining compliant joints in series leads to a decreased stability of the center of rotation. When combined in parallel, the force required to actuate the surrogate fold will be doubled, but increased stiffness to torsion and lateral bending is achieved. By creating a pattern of compliant joints along the axis of the fold the properties of the surrogate folds can be changed substantially.

Table 3.2: Compliant joints and their secondary motions. Grey boxes indicate high stiffness resisting that motion while white boxes show the compliant joint in its deflected state for flexible directions.

	Bending-Orthogonal 	Mixed Tension Resistant 	Torsion-Parallel 	Mixed Compression Resistant 	Inverted Bending-Orthogonal 	Torsion-Parallel with Buckling 	Mixed Lateral Bending 
Torsion 							
Lateral Bending 							
Shear 							
Compression 							
Tension 							
Deflections 	Small	Large	Small	Small	Small	Large	Small
Fixed Center of Rotation 	Not Fixed	Not Fixed	Fixed	Not Fixed	Not Fixed	Not Fixed	Not Fixed

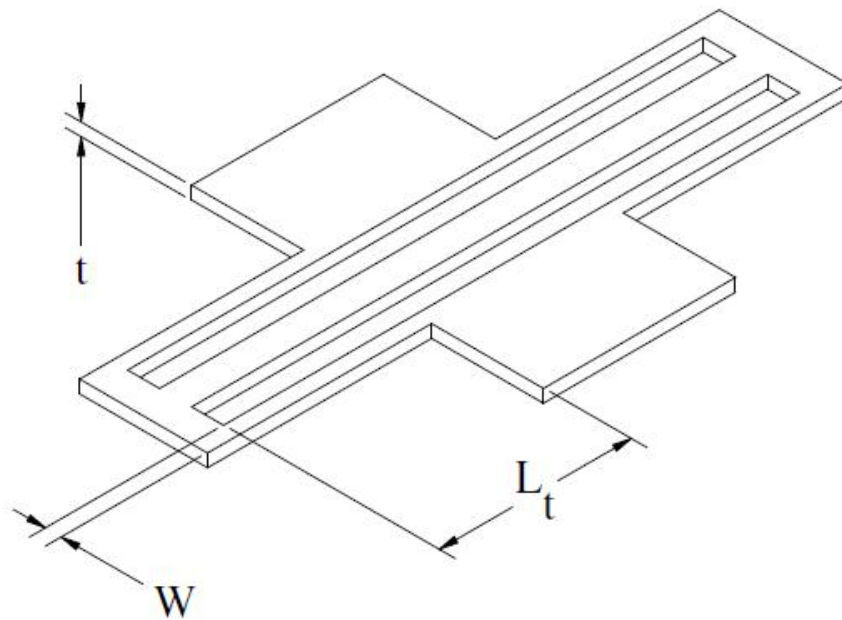

Figure 3.17: The Torsion-Parallel Joint with a buckling member added to give increased resistance to tension and compression as compared to the Outside LET.

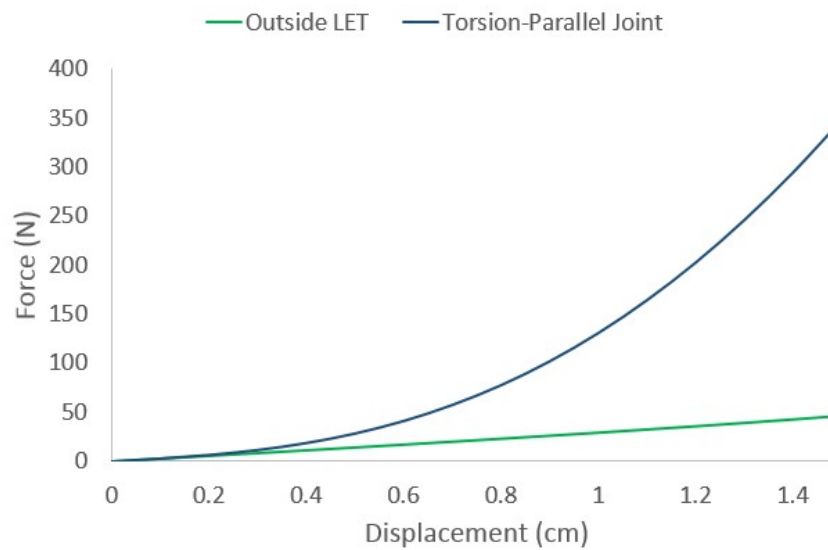

Figure 3.18: A comparison of the Torsion-Parallel Joint with Buckling Member and the Outside LET Joint when placed in tension. Both joints have $L = 5$ cm, $w = 0.4$ cm, $t = 0.4$ cm, and $E = 1.4$ GPa.

3.9.1 Torsion-Parallel Joint with Buckling Member

An example of a combined surrogate fold is the addition of a buckling member to the Torsion-Parallel Joint. The LET family of joints are excellent monolithic compliant joints for folding. However, they tend to be flexible in tension and compression [30]. For applications where large rotations are desired but tension and compression must be strengthened, new joints are needed.

The Torsion-Parallel Joint provides an increase in stiffness in compression and tension while maintaining flexibility in the folding direction. The torsional stiffness in folding of the Torsion-Parallel Joint with a buckling member added (shown in Figure 3.17) is given by [28]:

$$K_T = \frac{wt^3 \left(\frac{1}{3} - 0.21 \frac{t}{w} \left(1 - \frac{t^4}{12w^4} \right) \right) G}{L_T} \quad (3.13)$$

where $w \geq t$ and G is the shear modulus. Since the torsional members of the Outside LET provide most the deflection, the Torsion-Parallel Joint with a buckling member has a similar motion in folding while increasing resistance to tension and compression. This increase in stiffness to tension and compression is achieved by the addition of the central member, which creates a fixed-clamped boundary condition rather than fixed-guided. A comparison of the two joints in tension is shown in Figure 3.18. This data assumes the buckling member is perfectly rigid and does not undergo buckling. When the critical buckling force is reached the stiffness of the joint will decrease. The resistance to tension and compression of a single compliant member is given by Equations (3.11) through (3.12).

To avoid buckling in the central member, the compliant joint can be patterned along the axis of the fold and the central member extended, as shown in Figure 3.19.

3.9.2 Lateral Bending

Another example of achieving a unique motion by combining two or more dual-segment joints is lateral bending. Motion in lateral bending is sometimes desired but it is difficult for a surrogate fold to achieve lateral bending without also being flexible in torsion. If motion in torsion is acceptable, the Torsion-Parallel Joint with the torsional bars close together is recommended.

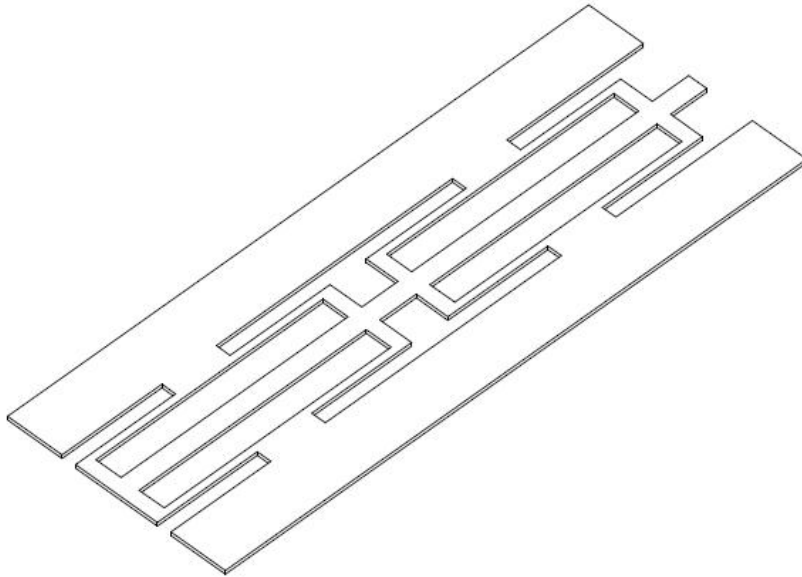

Figure 3.19: Torsion-Parallel Joint patterned along the line of the fold for further increased resistance to tension and compression.

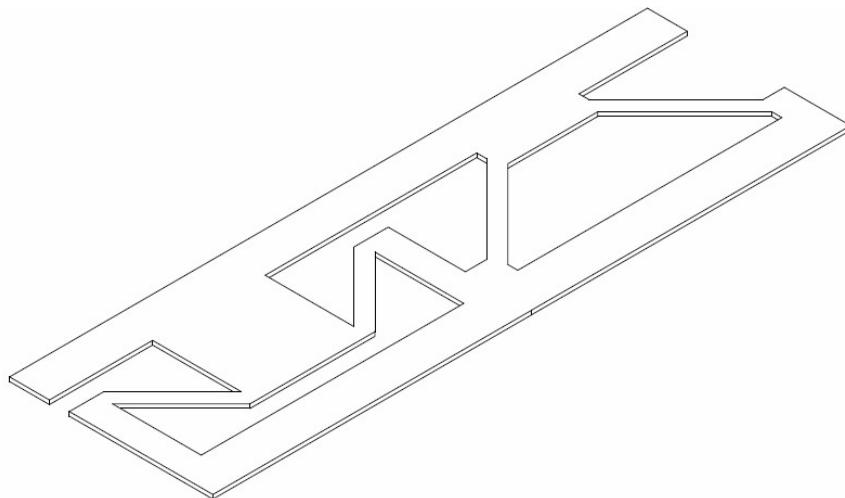

Figure 3.20: By combining the mixed tension and compression resistant joints a small amount of lateral bending can be achieved while maintaining high resistance to other motions.

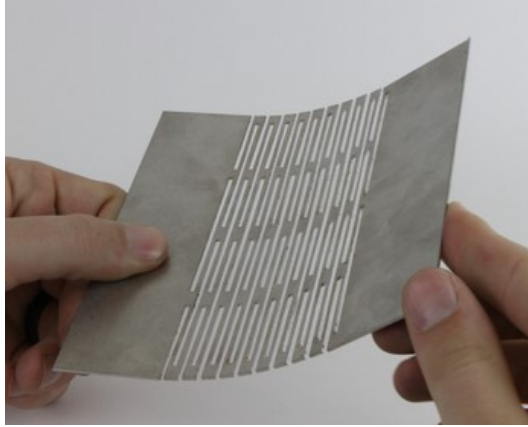

Figure 3.21: An array of Torsion-Parallel Joints in 1.214 mm thick 304 stainless steel capable of achieving 280° rotation (140° each direction) without yielding.

This modification will allow both lateral bending and torsion. If motion in the torsional direction is not acceptable then other options must be explored.

By coupling the Mixed Compression Resistant Joint and the Mixed Tension Resistant Joint (Figure 3.20) a surrogate fold which has decreased resistance to one direction of lateral bending can be created. The maximum displacement of this surrogate fold in lateral bending is limited.

3.10 Compliant Joint Arrays as Surrogate Folds

In applications where thickness is significant, a single compliant joint may not be able to achieve large enough deflections to meet the design objectives. By patterning a compliant joint both along the axis of the fold and away from the axis of the fold, greater deflection can be achieved at the expense of a fixed center of rotation. Figures 3.21 and 3.22 show an array of Torsion-Parallel Joints ($\phi = 90^\circ$) manufactured from stainless steel.

Arrays can also be employed with the Mixed Compression Resistant and Mixed Tension Resistant Joints. The array shown in Figure 3.23 will maintain the Mixed Compression Resistant Joint's ability to rotate out of plane, but is intrinsically susceptible to compression due to the instability of using multiple linkages to achieve deflection. The effect of patterning a compliant joint should be carefully considered before employing an array as a surrogate fold.

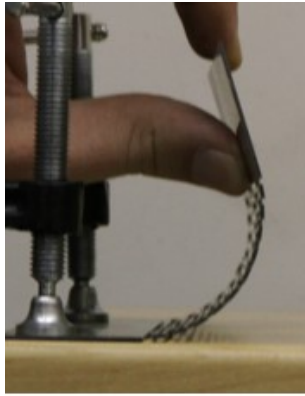

Figure 3.22: The array shown in Figure 3.21 actuated to beyond 90° .

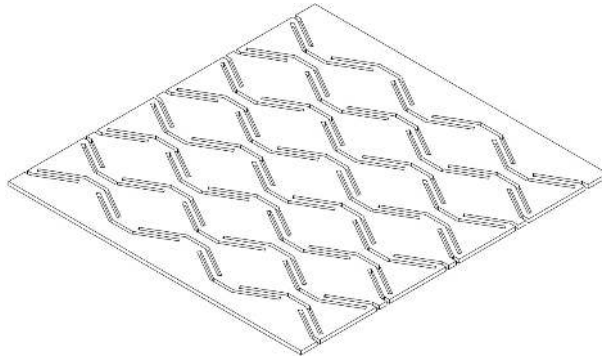

Figure 3.23: An array of Mixed Compression Resistant Joints to achieve added deflection in the folding motion.

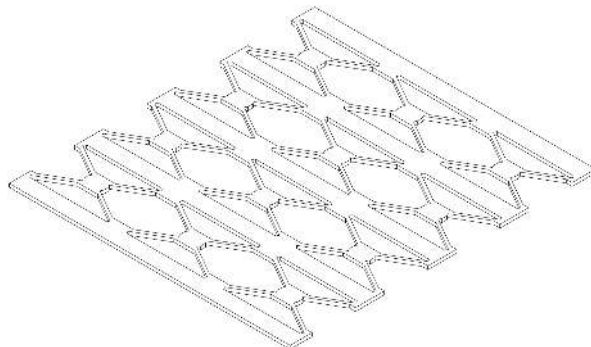

Figure 3.24: An array of Mixed Tension Resistant Joints providing an increased stiffness to tension compared to compression.

3.11 Design of Surrogate Folds

Like the design of compliant joints, the design of surrogate folds requires an understanding of the secondary or parasitic motions that the surrogate fold allows [16]. The family of dual-segment joints proposed in this paper allow the designer to customize which motions the surrogate fold will allow. A thorough understanding of the design of compliant joints allows the designer to create surrogate folds capable of achieving the desired motions in a given application.

Bending provides a simple, easy to model motion that is uniform in two directions. For this reason bending is often relied upon in simple surrogate folds, such as the Simple Reduced Area Joint. One of the major advantages to bending surrogate folds is their ease of modelling. However, stresses can be high in bending members, limiting the deflection achieved by the surrogate fold before failure. To alleviate this, longer bending members can be used. This increases the overall footprint of the surrogate fold.

Torsion provides large deflections while maintaining a relatively constant stiffness. Torsion members typically are placed parallel to the axis of the fold. This allows for a much smaller surrogate fold footprint. However, torsion members tend to be more susceptible to unwanted motions in compression and tension, which places the torsion members in bending. A longer torsion member will allow for greater deflection in folding, but will also leave the surrogate fold more susceptible to motion in the compression and tension directions.

By combining torsion and bending, as in the Compression Resistant Torsional Joint and the Tension Buckling Joint, the properties of the surrogate fold can be changed drastically. The Compression Resistant Torsional Joint utilizes torsional members angled slightly. This angle introduces an element of bending to the surrogate fold. This has a limited effect on the stiffness in the folding motion, but gives the joint a much higher resistance to compression, as the tension members are placed in tension.

Buckling provides an excellent method for achieving high stiffness in one motion while maintaining flexibility in the opposite direction. It is important to note that buckling can be induced in any direction, not only parallel to the direction of applied force. This is illustrated by Figure 3.17. The central member buckles perpendicular to the applied load.

Stress in a bending member is easily calculated as a cantilever beam with a force at the free end. When ϕ is equal to 90° the stress in the compliant member can be calculated as

$$\tau_{max} = \frac{T_i}{Q} \quad (3.14)$$

where T_i is the torque in the compliant member and Q is dependant on the geometry. For rectangular cross sections Q is given by [12]

$$Q = \frac{w^2 t^2}{3w + 1.8t} \quad (3.15)$$

The maximum shear stress occurs at the middle of the outermost surface on w (the longer of the two faces). When ϕ is not equal to 0 or 90° FEA is recommended as a means for evaluating the stress in the element.

3.12 Conclusion

In order to facilitate exploration of origami-inspired design new surrogate folds are necessary. Once acceptable secondary motions are identified, the designer can select a value of ϕ which will give the desired properties. This family of compliant joints allows the designer a systematic approach to creating surrogate folds for a given application.

Once an individual compliant joint has been identified, its properties can be substantially altered by combining the joints. Combining the joints along the axis of the fold results in several joints in parallel. Combining away from the fold axis results in several joints in series. When a joint is combined in both directions it is known as an array.

Dual-segment joint arrays can provide large deflections even when each unit undergoes a relatively small deflection. Additionally, arrays can maintain many of the advantages of dual-segment joints while increasing flexibility in the folding direction.

Future work will involve applications of these surrogate folds, particularly of the Mixed Tension Resistant and Mixed Compression Resistant joints. Additionally, exploration of the behavior of the dual-segment joint when used in an array or patterned along the axis of the fold would be beneficial.

CHAPTER 4. CONCLUSION

Origami-inspired design provides a unique approach to the development of space efficient designs. Folds in paper act as hinges which are capable of achieving 360 °of rotation and are not susceptible to parasitic motion. No existing surrogate fold gives all of these properties. By characterizing the motions of existing surrogate folds the designer is able to consider what motions are allowable and select a surrogate fold which gives the desired motion.

There are many existing surrogate folds; however, some potentially desirable motions are missing. For example, surrogate folds that allow motion in the tension direction while remaining stiff in the compression direction are lacking.

A variety of surrogate folds can be achieved by varying the property ϕ , which corresponds to the angle of the compliant member. For example, a ϕ value of 0 corresponds to the compliant member being placed purely in bending. When ϕ is equal to 90 the compliant member is placed purely in torsion.

The stiffness of the surrogate fold when placed in folding is given for all values of ϕ . Additionally, the stiffness to resist tension or compression is given for all values of ϕ .

By utilizing a variety of compliant joints the properties of the surrogate fold can be changed substantially. One method for combining compliant joints is to pattern joints along the axis of the fold. This method can achieve greater stiffness to torsion and lateral bending.

A compliant joint that is patterned both along the axis of the fold and perpendicular to this axis it is called an array. Arrays can give high resistance to many secondary motions and achieve large deflections. However, the center of rotation for an array is not as fixed as when a single compliant joint is used.

While a wide variety of compliant joints have been identified for possible use in surrogate fold applications, there are many areas of exploration available for future work. These compliant joints all have closed form solutions presented for their motion in folding and at least one of the

secondary motions considered. These equations provide an excellent means to model the motion of a single surrogate fold. However, modelling multiple compliant joints adds increased complexity.

When a compliant joint is patterned along the axis of the fold it is modelled as several compliant joints in parallel. However, an accurate model for secondary motions is not proposed. For example, the combined surrogate fold allowing motion in shear is not modelled. Many new combined compliant joints could be created which would be suitable for use as surrogate fold and produce interesting motions.

Arrays provide a means to achieve large deflections in thick materials by patterning compliant joints in series. Arrays are of particular use in materials not traditionally considered compliant, such as metals. Further exploration of the behavior of arrays would be beneficial to designers attempting to create surrogate folds in these materials. Further research to investigate arrays which consist of more than one type of compliant joint would be of interest.

REFERENCES

- [1] Zirbel, S. A., Wilson, M. E., Magleby, S. P., and Howell, L. L., 2013. “An origami-inspired self-deployable array.” In *Proceedings of the ASME 2013 Conference on Smart Materials, Adaptive Structures and Intelligent Systems*. 1, 7, 21, 25
- [2] Kuribayashi, K., Tsuchiya, K., You, Z., Tomus, D., Umemoto, M., Ito, K., and Sasaki, M., 2006. “Self-deployable origami stent grafts as a biomedical application of ni-rich tini shape memory alloy foil.” *Materials Science and Engineering*, **A 419**, pp. 131 – 137. 1, 23
- [3] Schenk, M., and Guest, S., 2011. “Origami folding: A structural engineering approach.” In *Origami 5: Fifth International Meeting of Origami Science, Mathematics, and Education*, P. Wang-Iverson, R. Lang, and M. Yim, eds., Vol. , CRC Press, pp. 291–304. 1, 23
- [4] Klett, Y., and Drechsler, K., 2011. “Designing technical tessellations.” *International Meeting of Origami Science, Mathematics, and Education*, **5**, pp. 305–322. 1, 23
- [5] Wu, W., and You, Z., 2010. “Modelling rigid origami with quaternions and dual quaternions.” *The Royal Society*, **466**, pp. 2155–2174. 1, 23
- [6] Dureisseix, D., 2012. “An overview of mechanisms and patterns with origami.” *International Journal of Space Systems*, **27**(1), pp. 1–14. 1, 5, 23
- [7] Balkcom, D. J., and Mason, M. T., 2008. “Robotic origami folding.” *The International Journal of Robotics Research*, **27**, pp. 613–627. 1, 5, 23
- [8] Dai, J. S., and Cannella, F., 2008. “Stiffness characteristics of carton folds for packaging.” *Journal of Mechanical Design*, **130**, p. 022305. 1, 5, 23
- [9] Howell, L. L., 2001. *Compliant Mechanisms*. John Wiley & Sons, Inc., New York, NY. 2, 9, 10, 11, 13, 24, 26, 31, 32, 33
- [10] Greenberg, H. C., Gong, M. L., Magleby, S. P., and Howell, L. L., 2011. “Identifying links between origami and compliant mechanisms.” *Mechanical Sciences*, **2**, pp. 217–225 *Mechanical Sciences* is a special issue associated with the Second International Symposium on Compliant Mechanisms, Delft, The Netherlands. 2
- [11] Jacobsen, J., Winder, B., Howell, L., and Magleby, S., 2010. “Lamina emergent mechanisms and their basic elements.” *Journal of Mechanisms and Robotics*, **2**(1), pp. 011003–1 to 011003–9. 2
- [12] Jacobsen, J. O., Chen, G., Howell, L. L., and Magleby, S. P., 2009. “Lamina emergent torsional (LET) joint.” *Mechanism and Machine Theory*, **44**(11), pp. 2098 – 2109. 2, 11, 13, 14, 25, 34, 46

- [13] Demaine, E., 2001. “Folding and unfolding linkages, paper, and polyhedra.” In *Discrete and Computational Geometry*, J. Akiyama, M. Kano, and M. Urabe, eds., Vol. 2098 of *Lecture Notes in Computer Science*. Springer Berlin / Heidelberg, pp. 113–124. 5
- [14] Olsen, B. M., Isaac, Y., Howell, L. L., and Magleby, S. P., 2010. “Utilizing a classification scheme to facilitate rigid-body replacement for compliant mechanism design.” *ASME Conference Proceedings*, **2010**, pp. 475–489. 6
- [15] Olsen, B. M., Hopkins, J. B., Howell, L. L., Magleby, S. P., and Culpepper, M. L., 2009. “A proposed extendable classification scheme for compliant mechanisms.” *ASME Conference Proceedings*, **2009**, pp. 1–8. 6
- [16] Trease, B. P., Moon, Y.-M., and Kota, S., 2005. “Design of large-displacement compliant joints.” *ASM*, **127**, pp. 788–798. 6, 45
- [17] Howell, L., Magleby, S., and Olsen, B., 2013. *Handbook of Compliant Mechanisms*. John Wiley & Sons, Inc., New York, NY. 6
- [18] Lombontiu, 2003. *Compliant Mechanisms: Design of Flexure Hinges*. CRC Press. 9
- [19] Tian, Y., Shirinzadeh, B., Zhang, D., and Zhong, Y., 2010. “Three flexure hinges for compliant mechanism designs based on dimensionless graph analysis.” *Precision Engineering*, **Vol. 34**, pp. 92–100. 10
- [20] Wilding, S. E., Howell, L. L., and Magleby, S. P., 2012. “Spherical lamina emergent mechanisms.” *Mechanism and Machine Theory*, **49**, pp. 187–197. 15, 17, 25
- [21] Ferrell, D. B., Isaac, Y. F., Magleby, S. P., and Howell, L. L., 2011. “Development of criteria for lamina emergent mechanism flexures with specific application to metals.” *Journal of Mechanical Design*, **133**, pp. 031009–1 to 031009–9. 19, 20
- [22] Zirbel, S. A., Lang, R. J., Magleby, S. P., Thomson, M. W., Sigel, D. A., Walkemeyer, P. E., Trease, B. P., and Howell, L. L., 2013. “Accommodating thickness in origami-based deployable arrays.” *Journal of Mechanical Design*, **135**, p. 111005. 23
- [23] Francis, K. C., Rupert, L. T., Lang, R. J., Morgan, D. C., Magleby, S. P., and Howell, L. L., 2014. “From crease pattern to product: Considerations to engineering origami-adapted designs.” In *Proceedings of the ASME International Design Engineering Technical Conferences*, ASME DETC2014-34031. 23
- [24] Francis, K. C., Blanch, J. E., Magleby, S. P., and Howell, L. L., 2013. “Origami-like creases in sheet materials for compliant mechanism design.” *Mechanical Sciences*, **4**, pp. 371–380. 23
- [25] Su, H.-J., 2008. “A load independent pseudo-rigid-body 3r model for determining large deflection of beams in compliant mechanisms.” Vol. 2, ASME, International Design Engineering Technical Conferences and Computers and Information in Engineering Conference. 24

- [26] Delimont, I. L., Magleby, S. P., and Howell, L. L., 2014. “Evaluating compliant hinge geometries for origami-inspired mechanisms.” In *Proceedings of the ASME International Design Engineering Technical Conferences*, ASME DETC2014-34376. 24, 25
- [27] Huang, H., Deng, Z., Qi, X., and Li, B., 2013. “Virtual chain approach for mobility analysis of multiloop deployable mechanisms.” *Journal of Mechanical Design*, **135**, p. 111002. 25
- [28] Young, W. C., Budynas, R. G., and Sadegh, A. M., 2012. *Roark’s Formulas for Stress and Strain.*, eighth edition ed. McGraw-Hill. 27, 41
- [29] Howell, L. L., DiBiasio, C. M., Cullinan, M. A., Panas, R., and Culpepper, M. L., 2010. “A pseudo-rigid-body model for large deflections of fixed-clamped carbon nanotubes.” *Journal of Mechanisms and Robotics*, **2**(3), pp. 034501–1 to 034501–5. 34
- [30] Wilding, S. E., Howell, L. L., and Magleby, S. P., 2011. “Introduction of planar compliant joints designed for bending and axial loading conditions in lamina emergent mechanisms.” *Mechanism and Machine Theory*, **56**, August, pp. 1–15. 41