

NASA Contractor Report 187047

11 33

1630

P. 29

Measured Performance of the Half-Scale Accurate Antenna Reflector

(NASA-CR-187047) MEASURED PERFORMANCE OF
THE HALF-SCALE ACCURATE ANTENNA REFLECTOR
Final Report (Analex Corp.) 29 p CSCL 09A

N91-19350

63/33 Unclas
0001630

Kevin M. Lambert
Analex Corporation
Fairview Park, Ohio

December 1990

Prepared for
Lewis Research Center
Under Contract NAS3-25776

NASA

National Aeronautics and
Space Administration



MEASURED PERFORMANCE OF THE HALF-SCALE ACCURATE ANTENNA REFLECTOR

Kevin M. Lambert
Analex Corporation
Fairview Park, Ohio 44126

SUMMARY

A corrugated horn has been designed and fabricated for use as a feed for the half-scale accurate antenna reflector. This feed allows the reflector to be used in a compact range configuration as part of a microwave reflectance measurement system. This report describes the horn design and presents the measured farfield patterns of the horn. The horn was installed at the focus of the reflector and the near-field of the antenna was measured. The results of these measurements are presented and discussed with respect to the compact range application.

INTRODUCTION

Previous studies have investigated the use of the half-scale, accurate antenna reflector as a reflector for a compact range measurement system. The first study (ref. 1) was an examination of the quiet zone which would be produced by the reflector. Various aperture tapers were assumed and the near-field response of the reflector was calculated for each taper. The quiet zones which were produced were evaluated with respect to the requirements found in (ref. 2). These requirements state that the quiet zone should contain no more than 1 dB of amplitude taper and less than 0.1 dB of amplitude ripple. The study found that aperture tapers in excess of -30 dB would be needed in order to meet the ripple requirement. The high taper is necessary to reduce the diffraction from the edge of the reflector which is the dominate cause of the ripple.

A suitable feed horn design, which would produce this high aperture taper was not found. Therefore, another study (ref. 3) was performed to determine the error levels which the ripple would cause in the planned experiment. The conclusion of this study was that a -20 dB taper could be used without significantly affecting the results of the measurement. Practical feed horns can be designed and built to generate this taper in the aperture.

The design of a feed horn, to produce such a taper on the half-scale reflector, will be reported here. The horn was fabricated in the machine shop at NASA Lewis Research Center (LeRC). The pattern performance of the horn was measured in the Far-Field Laboratory at LeRC. The results of the measurements are presented and compared to theoretical predictions of the patterns.

After completion of the far-field tests, the horn was mounted with the half-scale reflector in the Near-Field Test Facility at LeRC. Near-field tests of the horn/reflector combination were performed over the frequency range of the horn. The results of these tests are also presented in this report. These results indicate the quiet zone that is produced and therefore they are analyzed with respect to the original requirements.

REFLECTOR FEED HORN DESIGN

As was mentioned in the introduction, the first requirement of the reflector feed is to produce a -20 dB taper in the reflector aperture. This characteristic

essentially determines the size of the feed aperture. Other considerations define the type of feed to use. A corrugated horn type feed was chosen for several reasons. A properly designed corrugated horn will produce a symmetric co-polar pattern over a wider frequency range than other types of feeds. This characteristic will provide for a relatively symmetric quiet zone. Additionally, the corrugated horn has low cross-polarization and low backlobe levels. The low backlobe levels are important in that the direct illumination of the quiet zone by the feed is insignificant. The size and weight of the feed are not a consideration in this system. Therefore, a corrugated horn is well suited for this application.

A method for designing corrugated horns may be found in reference 4. That method and the design curves presented in the reference were used to assist in the design of this corrugated horn. To verify the required aperture size, the Body of Revolution (BOR) Moment Method model of circularly symmetric feed horns (ref. 5) was used. This model is an option contained in The Ohio State University Reflector Antenna Code (ref. 6).

Figure 1 shows the angles subtended by the half-scale reflector, from the focus. To ensure that the taper is -20 dB or greater, the feed should be designed to produce a main beam that has a -20 dB beamwidth of about 36°, at the lowest frequency of operation. The size aperture that the horn would need to do this can be estimated from the universal curves shown in figure 2 (ref. 7). In this figure the parameter,

$$\frac{\Delta}{\lambda} = \frac{a^2}{2\ell} \quad (1)$$

represents the spherical phase cap introduced by the flare angle of the horn. In equation (1), a is the radius of the horn aperture, ℓ is the slant length and λ is the wavelength. The curves are plotted as a function of,

$$u = ka \sin \theta \quad (2)$$

where $k = 2\pi/\lambda$ and θ is the angle measured from the axis of the feed. Note, that the case with $\Delta/\lambda = 0$ represents a straight waveguide section. As Δ/λ gets larger, the flare angle increases and the length of the horn shortens. However, for narrower flare angles, the phase center of the horn varies less with frequency (ref. 4). Choosing $\Delta/\lambda = 0.2$, the -20 dB level occurs for $u = 5.3$. The horn is to operate in the X-Band frequency range. Therefore, solving for a at 8 GHz and $\theta = 18.296^\circ$ results in an aperture radius of 3.964 in. The corresponding full flare angle of the horn is 17.02°.

With this information, the OSU - Reflector Antenna Code can be used to generate a sample pattern of the horn. Figure 3 shows the calculated magnitude and phase pattern of the horn at 8 GHz. As planned the -20 dB beamwidth is nearly 36°. Patterns of the horn at higher frequencies could not be calculated because the large horn size required more Moment Method current elements than the computer could handle. However, the 8 GHz calculation reinforces the choice of aperture diameter.

The corrugations within the horn, the flare section and the throat region were designed following the guidelines provided in reference 4. Sketches of the horn design are given in figure 4. The design frequency for the corrugations was taken to be midband, 10 GHz. There are six corrugations per wavelength at this frequency. The width of the slots are 0.128 wavelength resulting in a ridge thickness of 0.038

wavelength. In the flare region of the horn, the depth of the corrugations is a constant 0.26 wavelength. In the throat region, which is the smooth wall to corrugated waveguide transition, the slot depths vary. This is done in order to improve the match between the two types of waveguide. The slot depths vary from 0.5 wavelength at the junction between the two waveguides, to 0.26 wavelength at the twenty-first slot. The manner in which the slot depths vary is determined from design curves provided in reference 4.

The horn was machined out of aluminum and had to be fabricated in three pieces. This was necessary in order to shorten the length that the tool had to be extended in order to cut the corrugations. At the junctions where the pieces would meet, a flange was machined on the exterior of the horn. The horn is then held together at the flanges with No. 10-32 screws.

The smooth wall input waveguide of the horn has a diameter that is one wavelength (1.180 in.) at the design frequency of 10 GHz. Again this is chosen to improve the match of the horn. Commercially available X-Band rectangular waveguide to circular waveguide transitions use a circular waveguide diameter of 1 in. Therefore, a WC 1.00 to WC 1.18 circular waveguide transition had to be designed and built for use with the corrugated horn. Figure 5 shows a drawing of the transition. A WR 90 to WC 1.00 rectangular to circular waveguide transition was obtained from Seavey Engineering Associates, Inc. (of Cohasset, MA). Finally, an HP model X281A coaxial to waveguide adapter is used to feed the horn assembly.

FAR-FIELD MEASUREMENTS OF THE REFLECTOR FEED

The far-field patterns of the corrugated horn were measured in the recently automated Far-Field Laboratory at Lewis (ref. 8). The corrugated horn was used in the receive mode and a Scientific-Atlanta model number 12-8.2 standard gain horn was used to transmit. In the original tests, the separation between the horns was on the order of 15 ft. Note that the $2D^2/\lambda$ distance for the corrugated horn is on the order of 10 ft at 12 GHz.

The patterns were taken in both the E-plane and the H-plane of the horn at frequencies of 8, 10, and 12 GHz. The patterns are displayed in figures 6 to 11. The patterns were not taken with the phase center of the horn over the center of rotation of the pedestal. Analysis of the measured phase patterns indicated that the phase center of the horn was located 4-9/16 in. behind the aperture of the horn. The phase patterns were processed to compensate for the difference between the center of rotation and the phase center. Figures 6 to 11 show the processed phase patterns.

The measured data shows that the corrugated horn has a 40°, -20 dB beamwidth at 8 GHz. This is slightly larger than what was desired but not enough to be of concern. Comparison of the E-plane data with the H-plane data shows that the main beam is symmetric to the -20 dB level at both 8 GHz and at 10 GHz. At 12 GHz, pattern symmetry suffers as the E-plane becomes narrower than the H-plane. Apparently this frequency is outside of the bandwidth of the corrugation designs used. Note, however that the H-plane is still on the order of -20 dB relative to the peak at 18°. This will probably result in a quiet zone of elliptical cross section at the higher end of the frequency band. The phase patterns of the horn remain relatively flat across the frequency band indicating that the phase center is insensitive to changes in frequency. Thus the reflector antenna should remain in focus at all frequencies when the horn is used as the feed.

Figure 12 shows a comparison of the calculated and measured data for the horn at 8 GHz. This plot indicates that the horn is performing as desired except for the slighter wider beamwidth at the -20 dB level.

REFLECTOR FEED MOUNT

For operation with the half-scale reflector, the corrugated horn is mounted within the reflector system such that the phase center of the horn coincides with the focus of the reflector. The focus of the reflector is located with respect to the reflector surface as shown in figure 13. As mentioned earlier, the phase center of the horn is located 4-9/16 in. behind the aperture of the horn. The corrugated horn is shown mounted in the reflector system in figure 14.

The horn is held in the reflector system by a feed mount that was designed specifically for this application. Figure 15 depicts the assembly drawing of the feed mount and the horn. The figure also shows the three sections that make up the corrugated horn. The flanges, where the sections of the horn meet, are used in the feed mount design to support the horn. Figure 16 identifies the six separate pieces which make up the feed mount. Detailed drawings of the individual pieces are given in figures 17 to 21.

Minor adjustment of the feed for focussing is accomplished with the slotted holes in the base plate, Part E. These slotted holes allow the horn to move along the line connecting the focus with the center of the reflector. No provision was made for side to side focussing because it was assumed that the support truss was fabricated accurately. The same is true for the tilt angle of the horn. Height adjustment could be accomplished by the use of shims, however subsequent testing proved that this was not necessary. The horn is mounted by the flanges using parts A and B. The symmetric bolt pattern allows the polarization of the horn to be set to vertical and horizontal as well as in the 45° planes.

The feed mount was fabricated and assembled in the shop located at the Near-Field Facility.

NEAR-FIELD MEASUREMENTS OF THE REFLECTOR SYSTEM

The half-scale reflector system, with the corrugated horn as a feed, was tested in the Near-Field Facility at LeRC (ref. 9). Figure 22 shows a photograph of the reflector system within the facility. The goal of these measurements was to probe the near-field of the antenna to determine the type of quiet zone that the system would generate. The near-field was sampled over a 2 by 2 m grid, which was centered on the antenna aperture. The sampling resolution was 20 mm. The range between the antenna and the scan plane was on the order of 15 ft. Data were taken at 8, 9, 10, 11, and 12 GHz for both vertical and horizontal feed polarization.

The vertical and horizontal center line scans of each test are presented here in order to characterize the quiet zone. The conditions of the test for each plot is summarized in the following two tables. Table I is the summary for tests when the feed was vertically polarized. Table II is for horizontal polarization of the feed.

PLOTS FOR VERTICAL POLARIZATION

Figure	Frequency, GHz	Scan
23	8.0	Vertical
24	8.0	Horizontal
25	9.0	Vertical
26	9.0	Horizontal
27	10.0	Vertical
28	10.0	Horizontal
29	11.0	Vertical
30	11.0	Horizontal
31	12.0	Vertical
32	12.0	Horizontal

TABLE II. - SUMMARY OF NEAR-FIELD PLOTS FOR HORIZONTAL POLARIZATION

Figure	Frequency, GHz	Scan
33	8.0	Vertical
34	8.0	Horizontal
35	9.0	Vertical
36	9.0	Horizontal
37	10.0	Vertical
38	10.0	Horizontal
39	11.0	Vertical
40	11.0	Horizontal
41	12.0	Vertical
42	12.0	Horizontal

The plots reveal the general characteristics of the quiet zone that is generated. The amplitude patterns show that some ripple remains from the diffraction at the edges of the reflector, even though the reflector is under illuminated. As would be expected, the shape of the near-field pattern becomes narrower as frequency increases. By using the criteria that the quiet zone is the region within the -1 dB taper of the near-field pattern, the amplitude plots can be used to estimate the size of the quiet zone. The sizes are estimates because the ripple makes it difficult to judge where to define the boundaries of the quiet zone. Table III is a summary of the estimate for vertical polarization of the feed. Table IV is the summary for horizontal polarization. The phase patterns indicate that the reflector remains in focus across the frequency range.

TABLE III. - SUMMARY OF QUIET ZONE SIZE FOR
VERTICAL POLARIZATION

Frequency, GHz	Vertical plane, in.	Horizontal plane, in.
8.0	10.3	11.3
9.0	10.8	11.3
10.0	9.8	12.3
11.0	8.9	7.6
12.0	7.9	11.1

TABLE IV. - SUMMARY OF QUIET ZONE SIZE FOR
HORIZONTAL POLARIZATION

Frequency, GHz	Vertical plane, in.	Horizontal plane, in.
8.0	10.3	11.3
9.0	10.8	10.3
10.0	9.8	10.3
11.0	9.4	9.8
12.0	8.6	8.4

CONCLUSION

The half scale reflector, with the described corrugated horn as a feed, produces a quiet zone that can be used for reflectance testing. The cross section of the quiet zone is roughly circular, with a 10 in. diameter. Therefore, the size of the test articles should be such that they fit within this region, if the -1 dB taper requirement is adhered to. Larger objects could be measured however the increased taper across the object must be kept in mind when interpreting the data.

The ripple levels in the quiet zone are small but it is doubtful that they are less than 0.1 dB. Note that in the actual near-field testing environment, the ripple can be caused by scattering from structures in the test area. This is in addition to the contribution from the reflector rim and direct feed illumination. The near-field scanner, which carries the probe, is a large metal structure as are the support beams and rails on the floor. Not all of these structures are covered with absorber. Consequently, there is the possibility that these structures will scatter into the quiet zone. The actual ripple levels should be acceptable for most testing.

A compact range type of measurement system can be developed around this horn and reflector combination. Further qualification of the quiet zone can be achieved by measuring the reflectance of standard test articles and comparing the data with theoretical results.

REFERENCES

1. Lambert, K.M.: Computed Performance of the Half-Scale Accurate Antenna Reflector. NASA CR-182284, 1989.

2. Burnside, W.D.; and Peters, L. Jr.: Target Illumination Requirements for Low RCS Target Measurements. Appendix I of Evaluation of Aperture Distribution Control to Obtain Improved Compact Range Reflector System Performance. Technical Report 312884-5, W.D. Burnside and T.H. Lee, ElectroScience Laboratory, Ohio State University, Columbus, OH, 1987.
3. Lambert, K.M.: Aperture Taper Determination for the Half-Scale Accurate Antenna Reflector. NASA CR-185215, 1990.
4. Clarricoats, P.J.B.; and Olver, A.D.: Corrugated Horns for Microwave Antennas. Peter Peregrinus Ltd., London, 1984.
5. Chuang, C.W.; and Lee, T.H.: Calculation of Fields Radiated by Rotationally Symmetric Horn Antennas Using Moment Method. Technical Report 717822-6, ElectroScience Laboratory, Ohio State University, Columbus, OH, 1987.
6. Lee, T.H.; Rudduck, R.C.; and Lambert, K.M. : Pattern Measurements of Reflector Antennas in the Compact Range and Validation with Computer Code Simulation. IEEE Trans. Antennas Propagat., vol. 38, no. 6, June 1990, pp. 889-895.
7. Johnson, R.C.; and Jasik, H., ed.: Antenna Engineering Handbook 2nd ed. McGraw-Hill, New York, 1984, figure 15-28.
8. Kunath, R.R.; and Terry, J.D.: Using a Modified HP8410 Network Analyzer as an Automated Far-Field Antenna Range Receiver. NASA TM-103700, 1990.
9. Sharp, G.R., et al.: Characteristics and Capabilities of the NASA Lewis Research Center High Precision 6.7- by 6.7-m Planar Near-Field Scanner. NASA TM-83785, 1984.

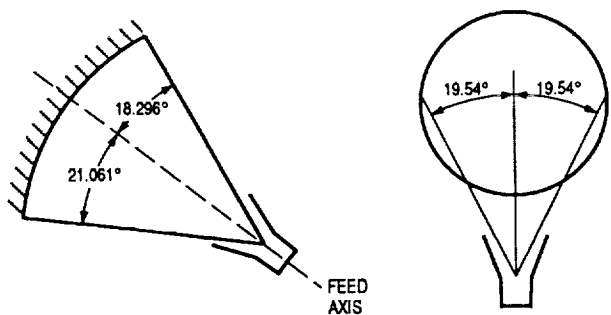

FIGURE 1. - LOCATION OF REFLECTOR EDGE IN FEED PATTERN COORDINATES.

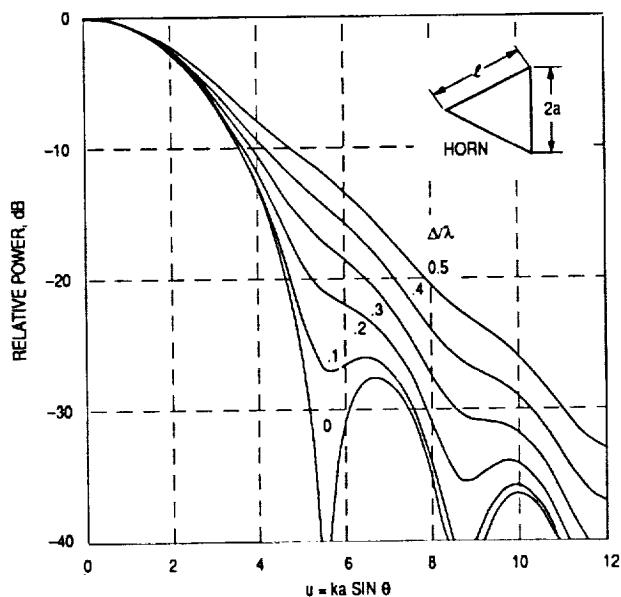
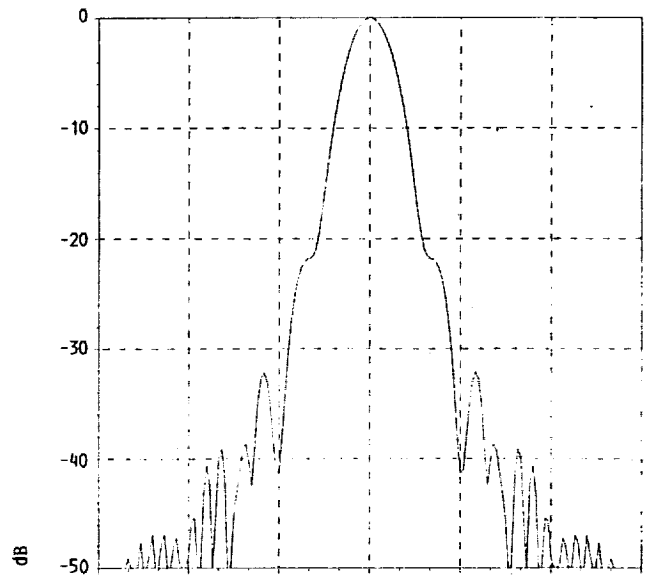
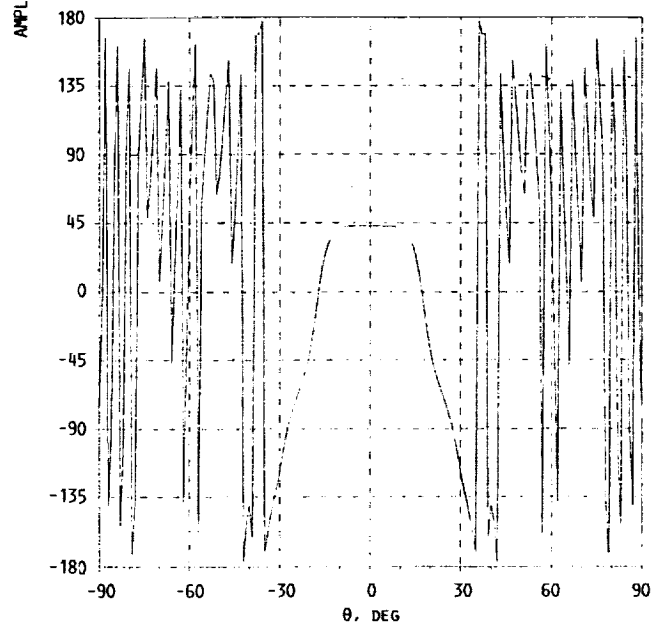

FIGURE 2. - UNIVERSAL PATTERNS FOR SMALL-FLARE-ANGLE CORRUGATED HORNS UNDER NEAR-BALANCED CONDITIONS (FROM REF 4.)



(a) AMPLITUDE PATTERN.



(b) PHASE PATTERN.

FIGURE 3. - CALCULATED PATTERN AT 8 GHz FOR A CORRUGATED HORN WITH A 7.928 INCH APERTURE DIAMETER AND A 17.02 DEGREE FLARE ANGLE.

ORIGINAL PAGE IS
OF POOR QUALITY

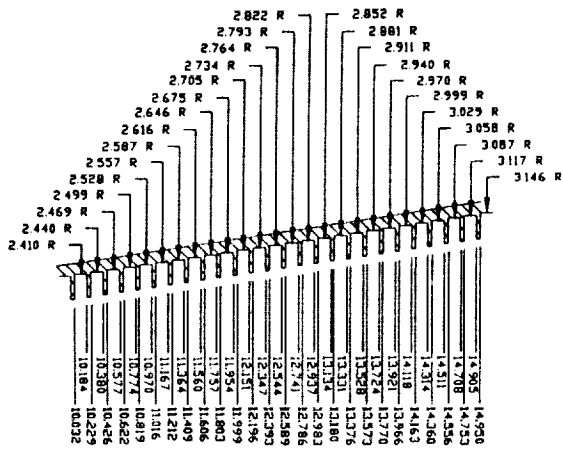

(d) SECTION C DETAIL.

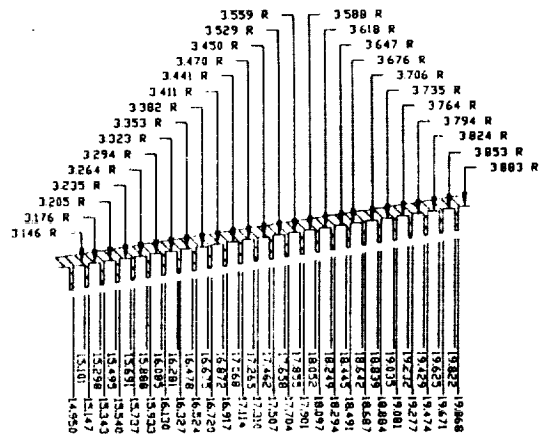

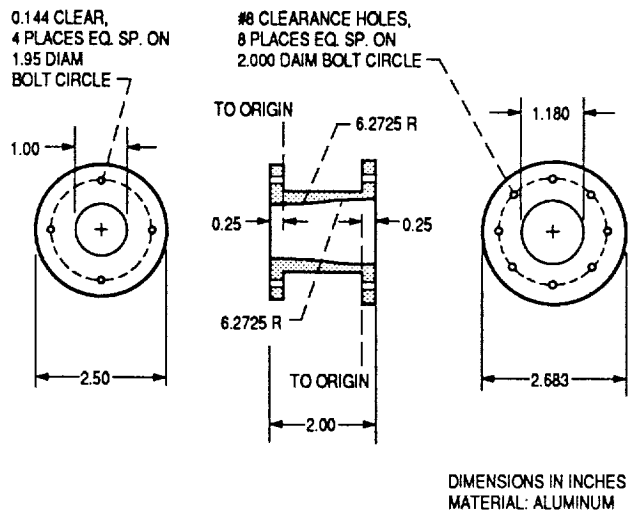
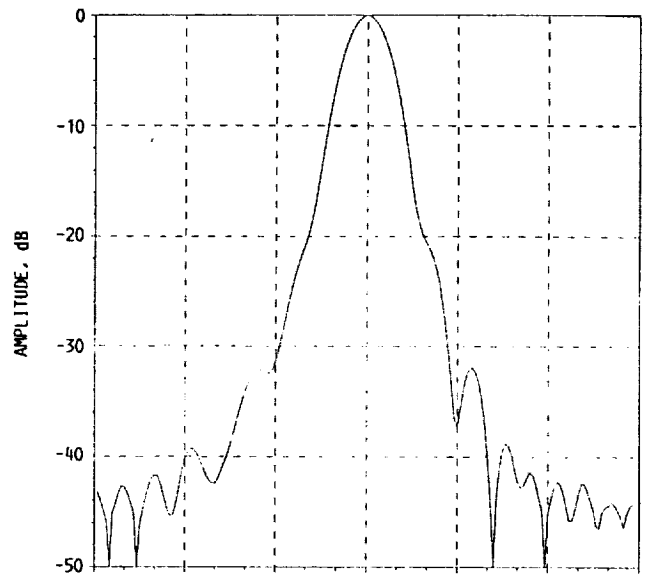
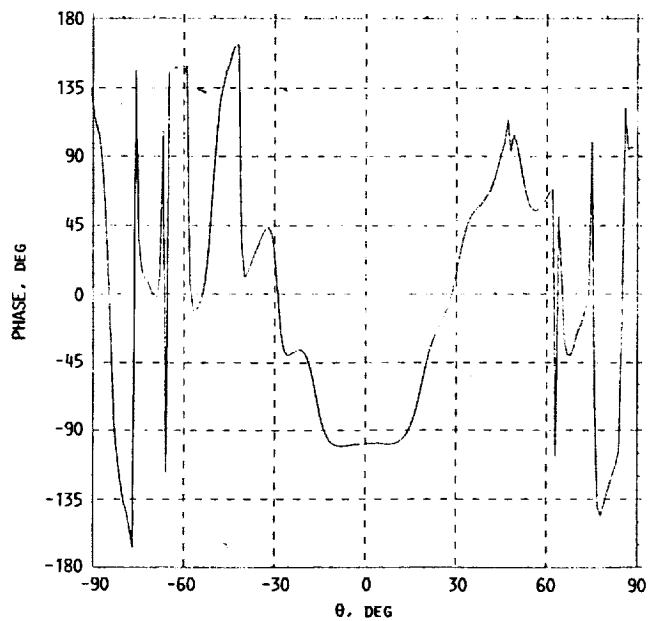

FIGURE 5. - WC 1.00 TO WC 1.18 WAVEGUIDE TRANSITION.



(a) AMPLITUDE PATTERN.



(b) PHASE PATTERN.

FIGURE 6. - MEASURED E-PLANE PATTERN OF THE CORRUGATED HORN AT 8 GHz.

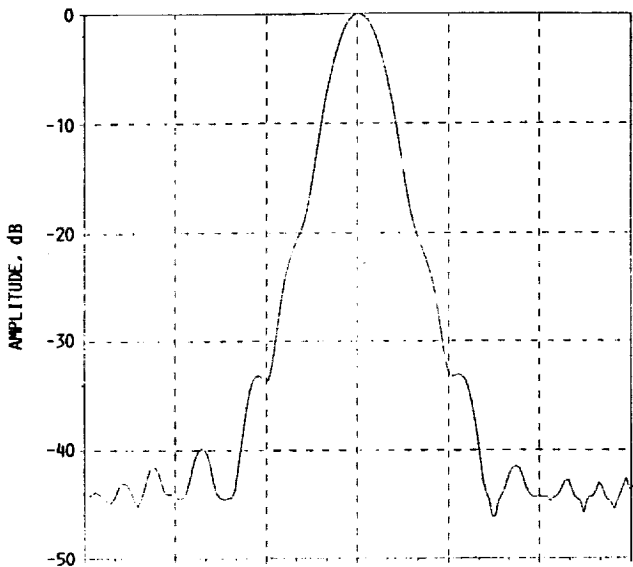

(a) AMPLITUDE PATTERN.

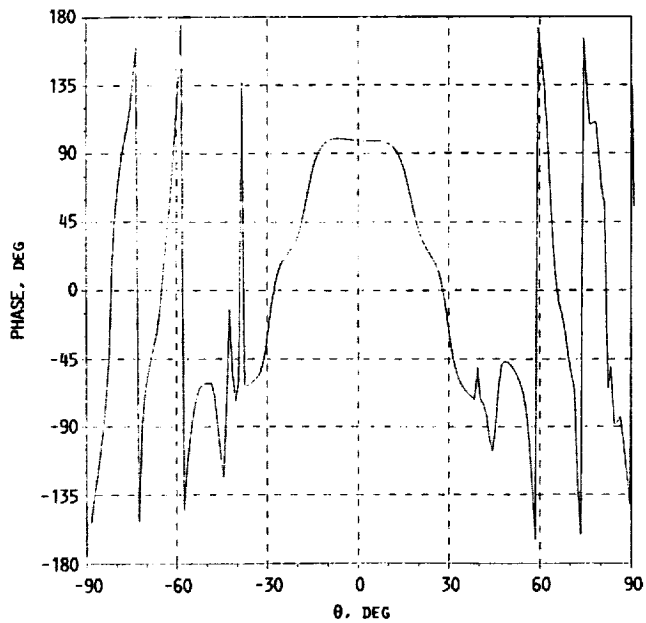

(b) PHASE PATTERN.

FIGURE 7. - MEASURED H-PLANE PATTERN OF THE CORRUGATED HORN AT 8 GHz.

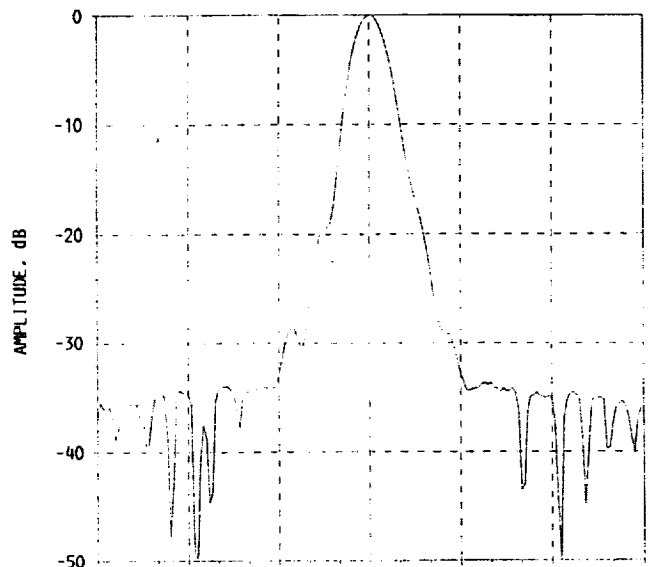

(a) AMPLITUDE PATTERN.

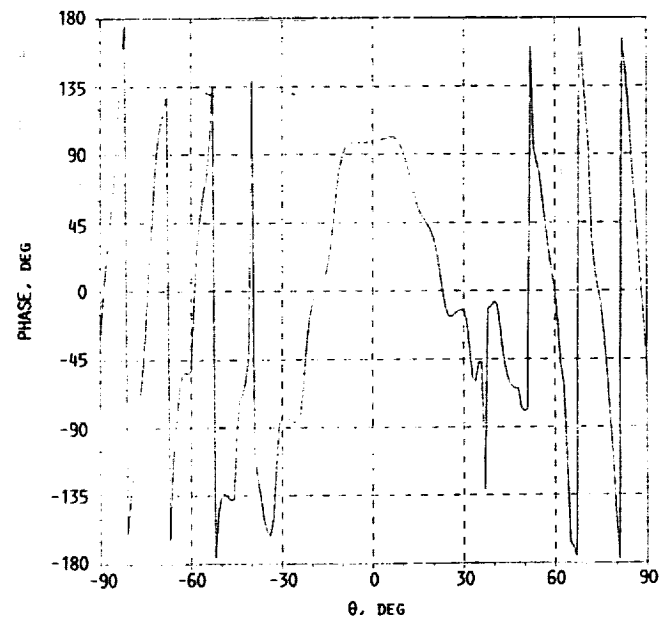

(b) PHASE PATTERN.

FIGURE 8. - MEASURED E-PLANE PATTERN OF THE CORRUGATED HORN AT 10 GHz.

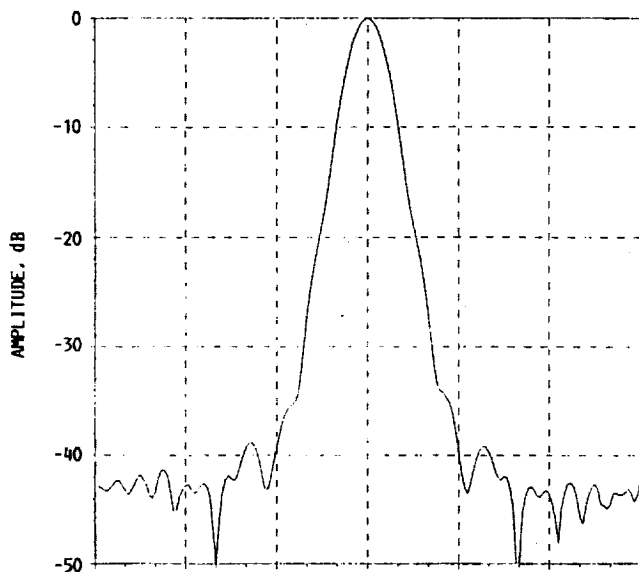

(a) AMPLITUDE PATTERN.

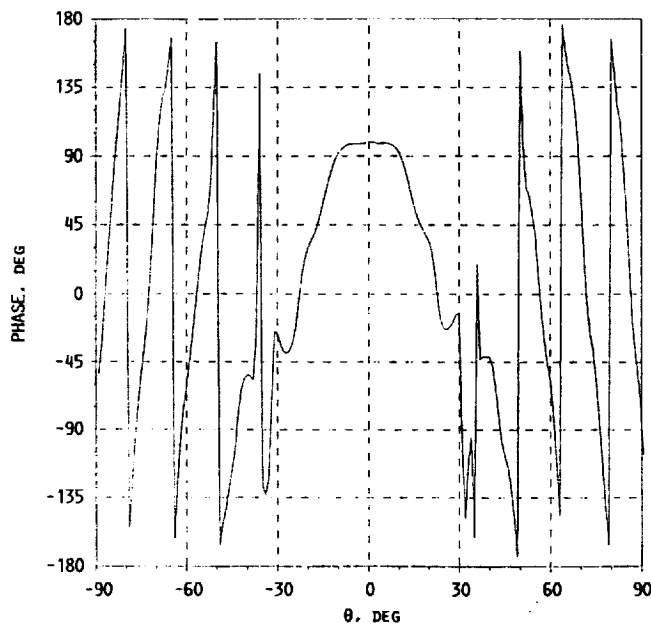

(b) PHASE PATTERN.

FIGURE 9. - MEASURED H-PLANE PATTERN OF THE CORRUGATED HORN AT 10 GHz.

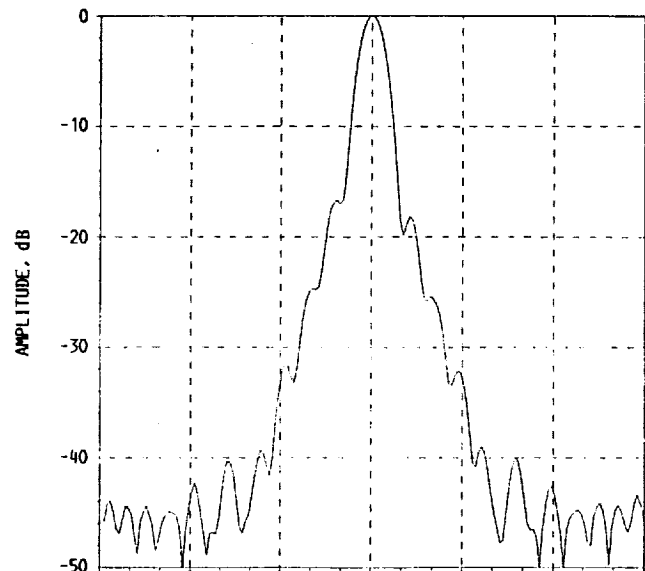

(a) AMPLITUDE PATTERN.

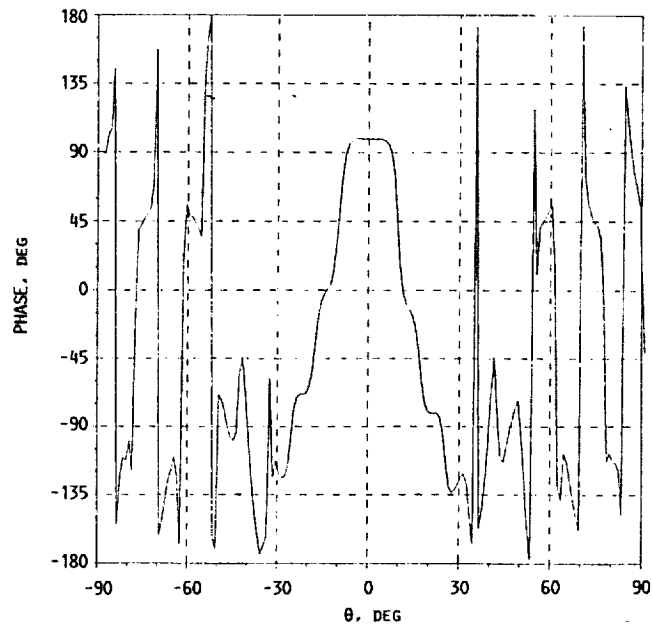

(b) PHASE PATTERN.

FIGURE 10. - MEASURED E-PLANE PATTERN OF THE CORRUGATED HORN AT 12 GHz.

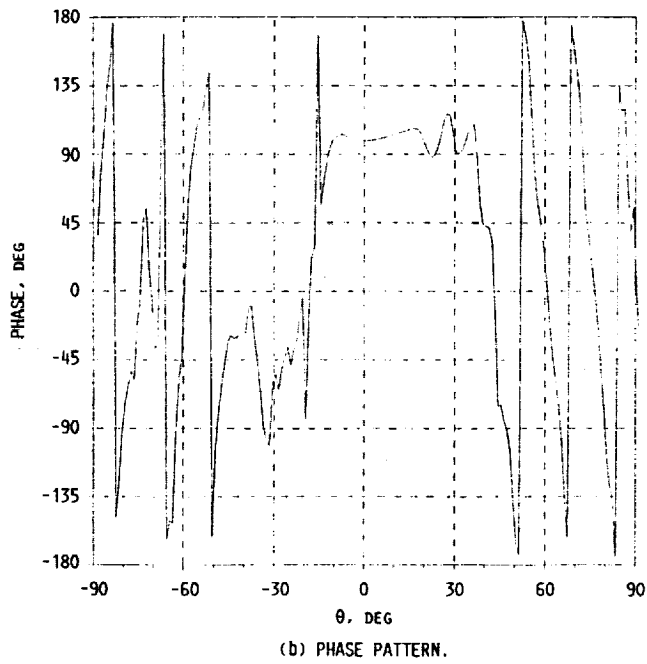
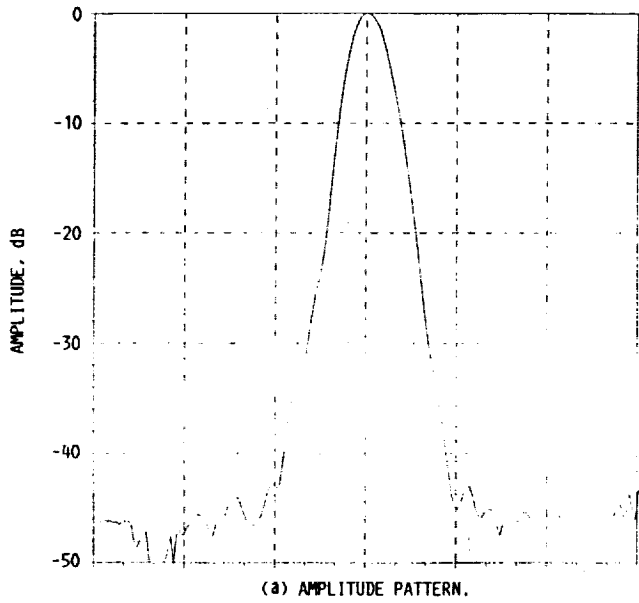
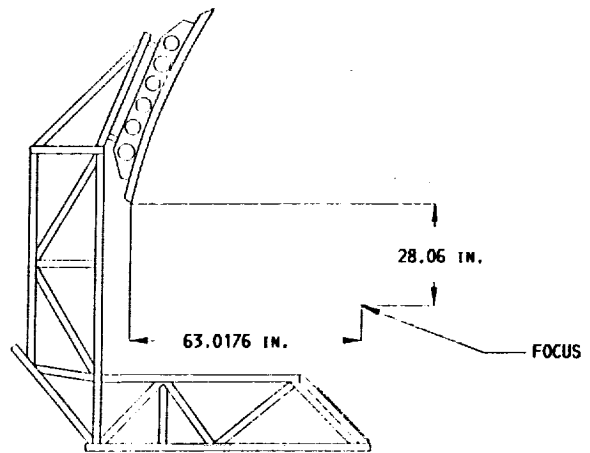
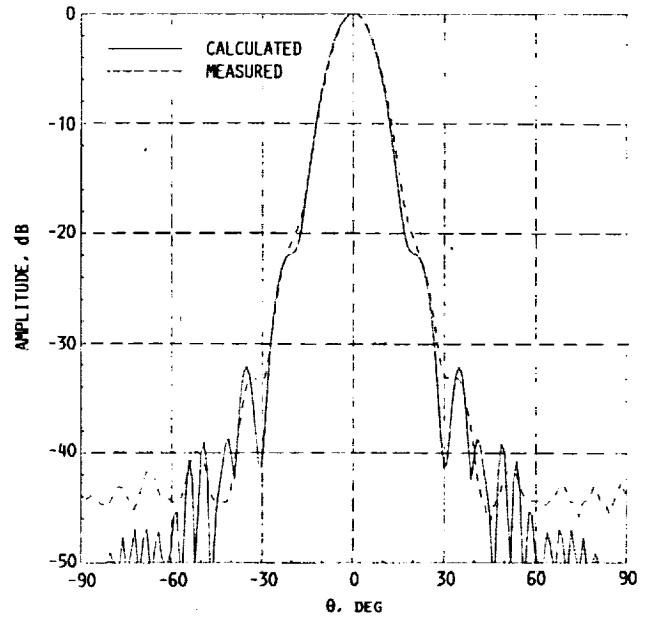

FIGURE 11. - MEASURED H-PLANE PATTERN OF THE CORRUGATED HORN AT 12 GHz.



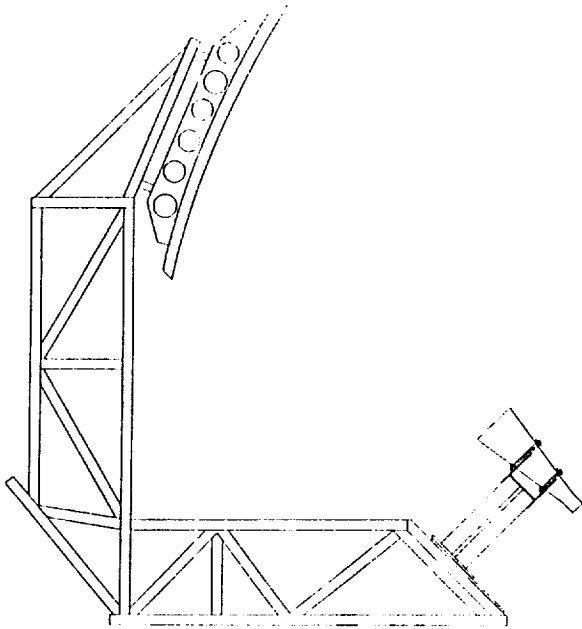

FIGURE 14. - CORRUGATED HORN AS A FEED FOR THE HALF-SCALE REFLECTOR.

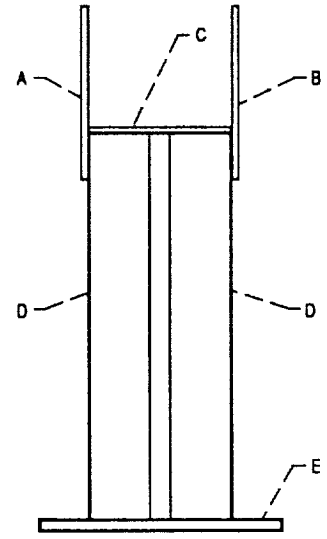

FIGURE 16. - PARTS IDENTIFICATION FOR THE REFLECTOR FEED MOUNT.

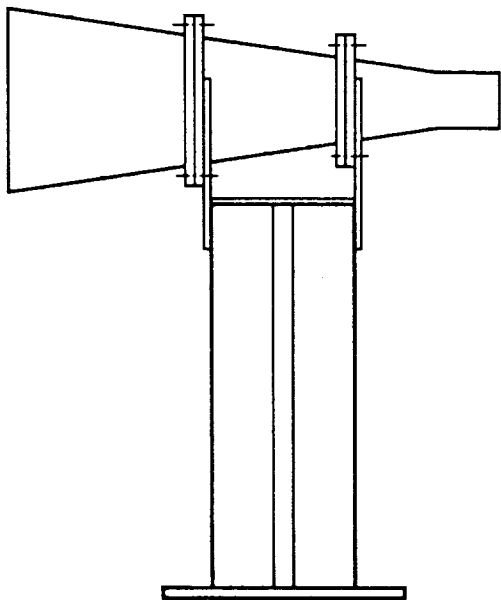

FIGURE 15. - ASSEMBLY DRAWING FOR THE CORRUGATED HORN AND THE REFLECTOR FEED MOUNT.

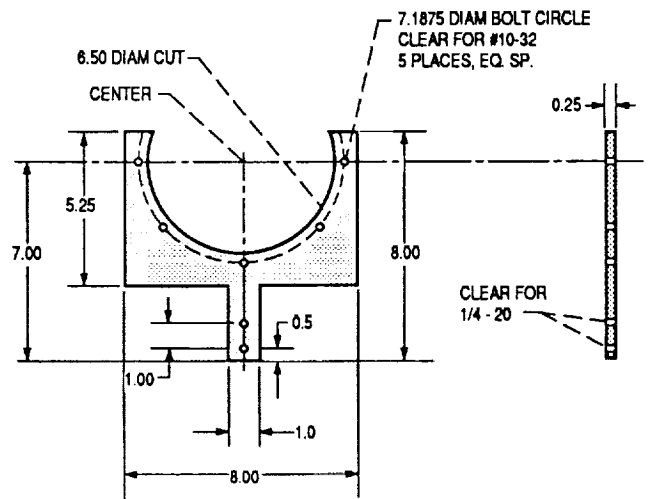

FIGURE 17. - PART A DETAIL OF THE REFLECTOR FEED MOUNT.

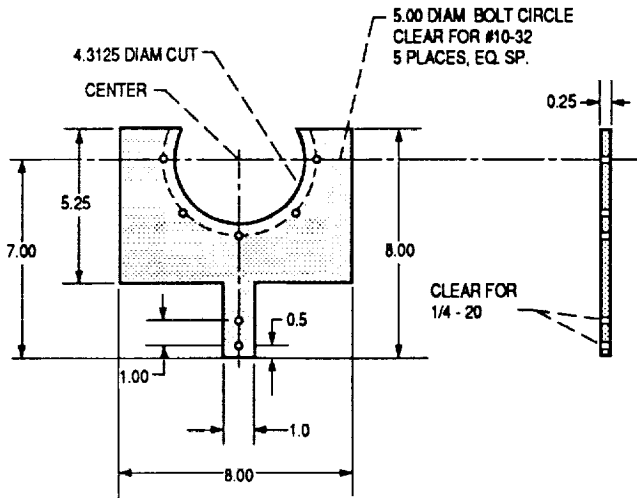

FIGURE 18. - PART B DETAIL OF THE REFLECTOR FEED MOUNT.

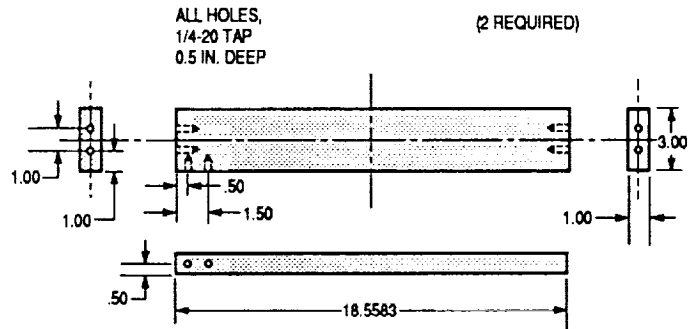

FIGURE 20. - PART D DETAIL OF THE REFLECTOR FEED MOUNT.

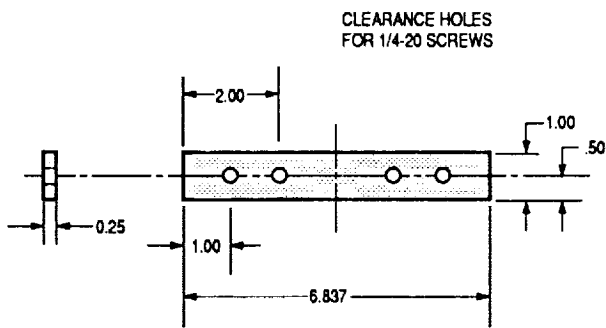

FIGURE 19. - PART C DETAIL OF THE REFLECTOR FEED MOUNT.

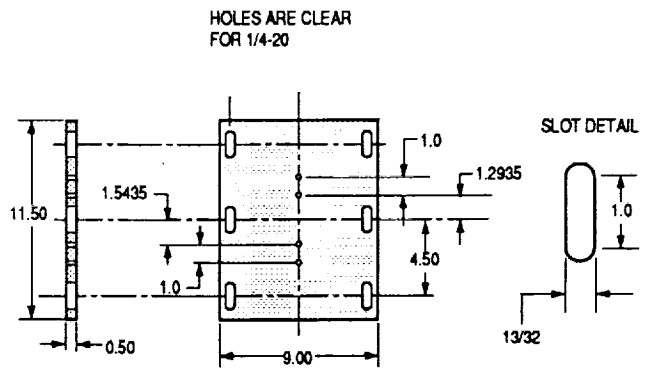

FIGURE 21. - PART E DETAIL OF THE REFLECTOR FEED MOUNT.

ORIGINAL PAGE
BLACK AND WHITE PHOTOGRAPH

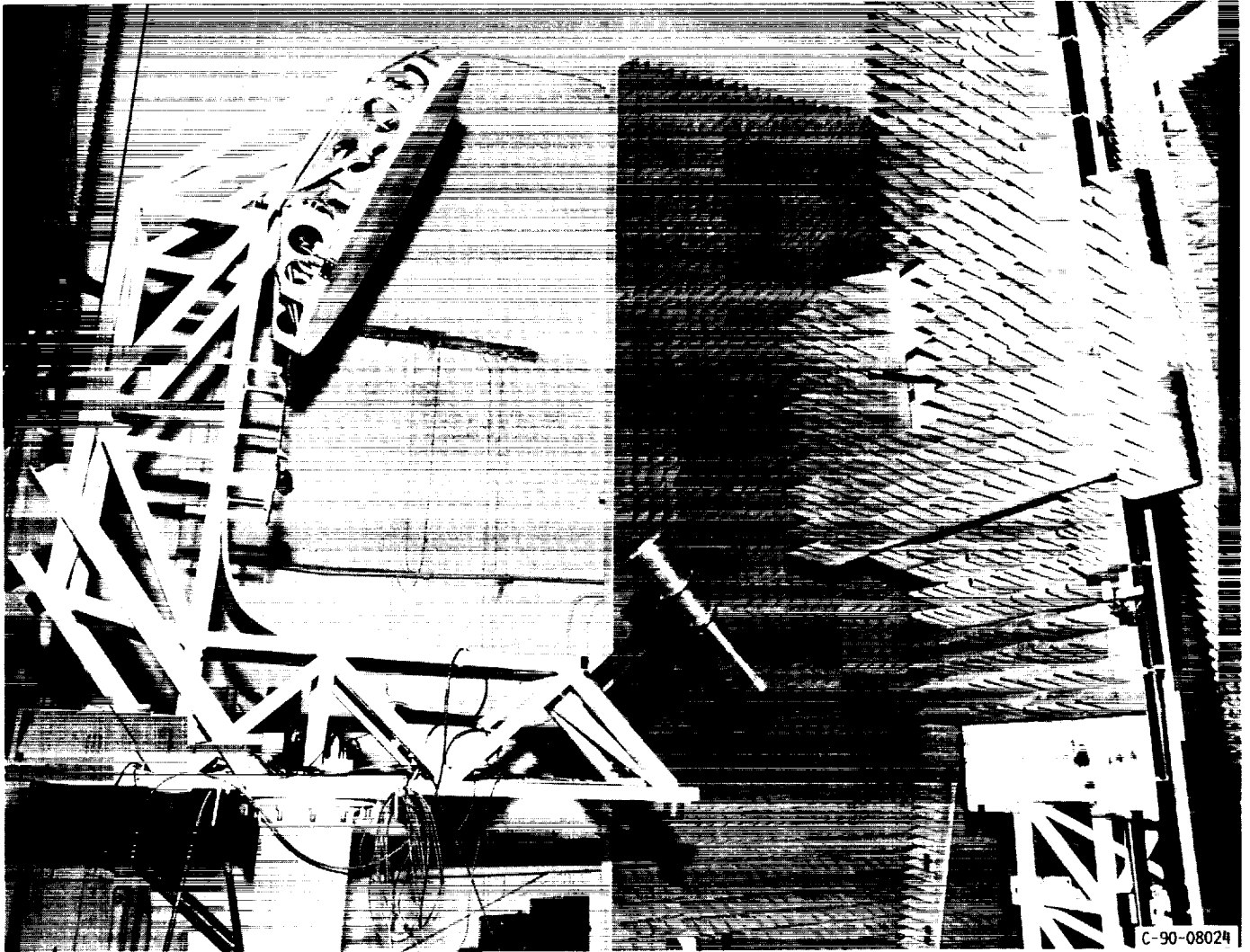
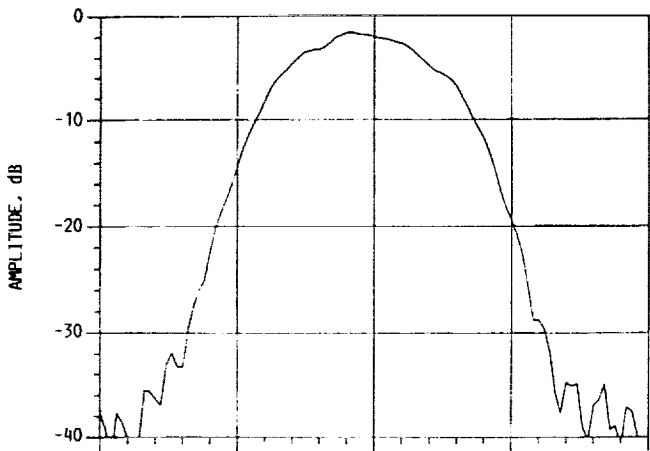
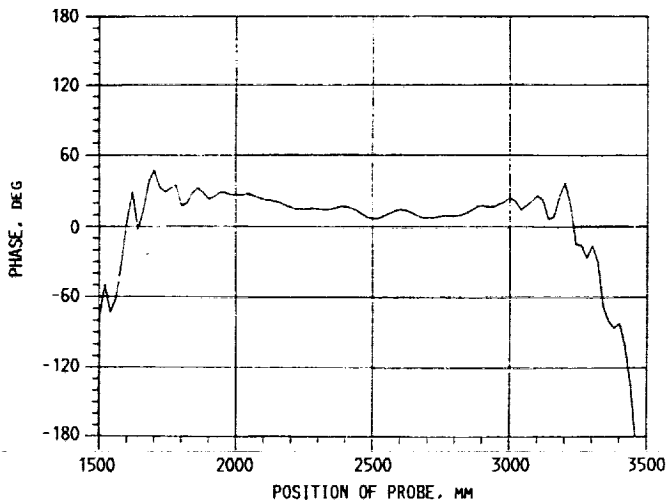

FIGURE 22.- THE CORRUGATED HORN AND REFLECTOR SYSTEM IN THE NASA LEWIS NEAR-FIELD FACILITY.



(a) AMPLITUDE PATTERN.



(b) PHASE PATTERN.

FIGURE 23. - NEAR-FIELD PATTERN AT 8 GHz OF THE REFLECTOR ANTENNA AND A VERTICALLY POLARIZED FEED. VERTICAL SCAN.

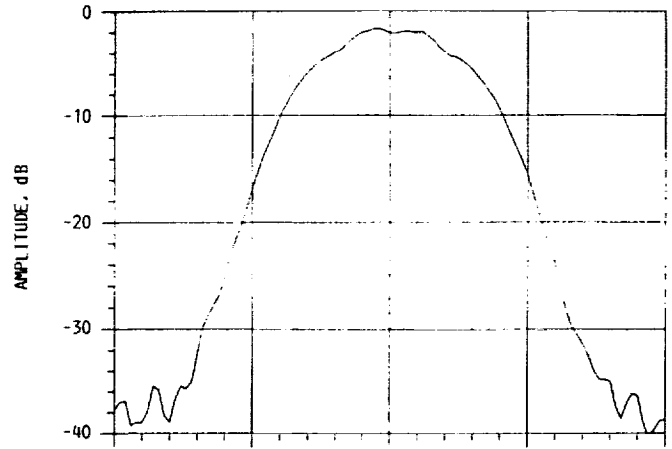

(a) AMPLITUDE PATTERN.

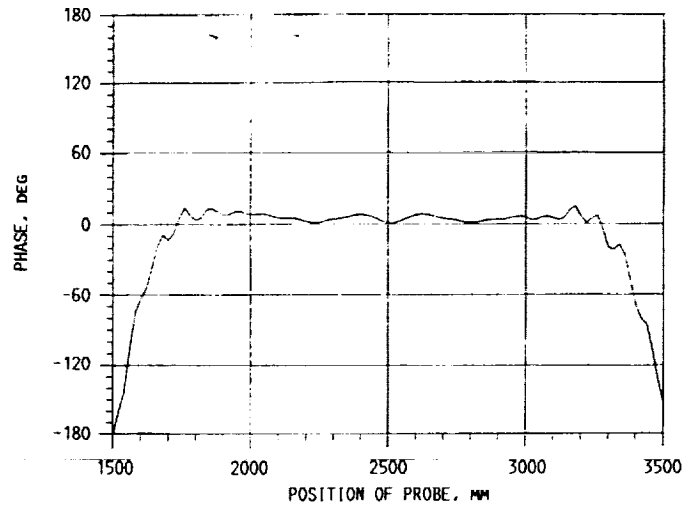

(b) PHASE PATTERN.

FIGURE 24. - NEAR-FIELD PATTERN AT 8 GHz OF THE REFLECTOR ANTENNA AND A VERTICALLY POLARIZED FEED. HORIZONTAL SCAN.

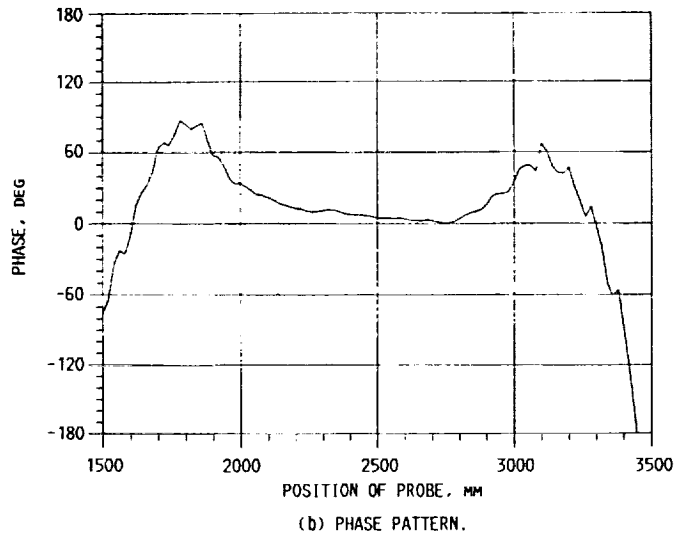
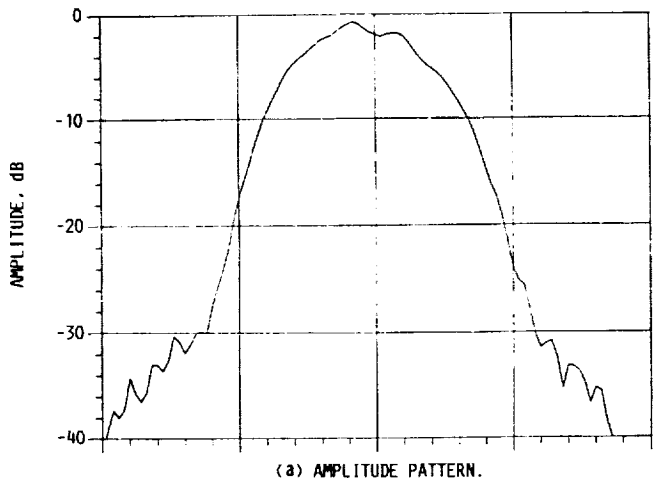

FIGURE 25. - NEAR-FIELD PATTERN AT 9 GHz OF THE REFLECTOR ANTENNA AND A VERTICALLY POLARIZED FEED. VERTICAL SCAN.

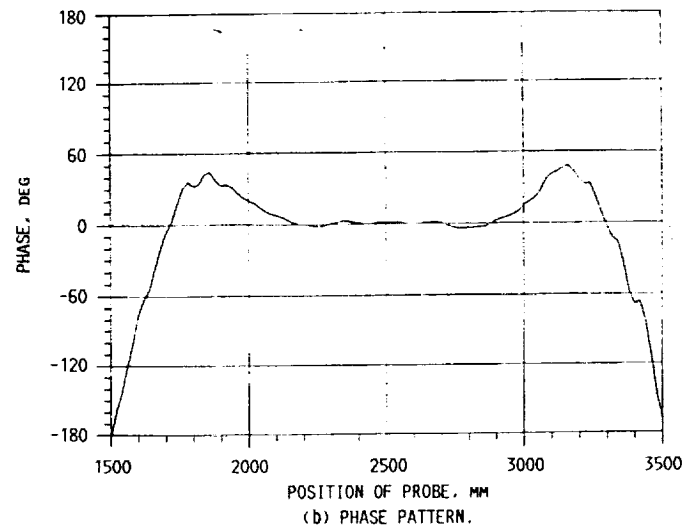
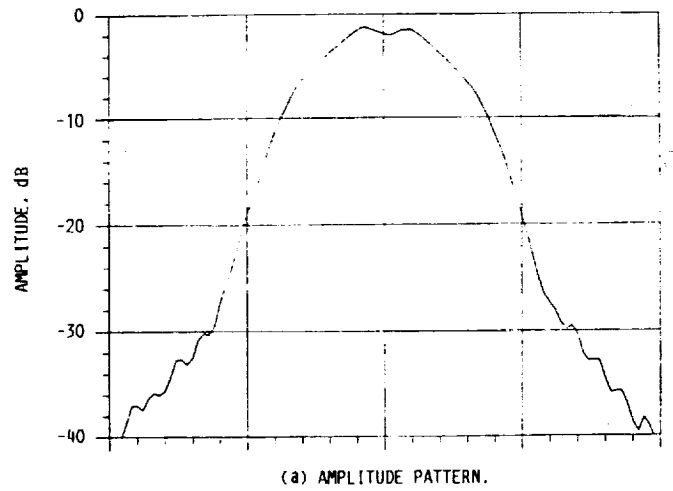
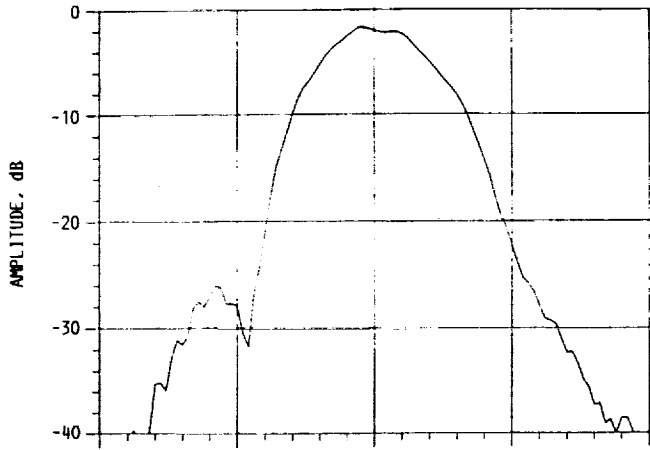
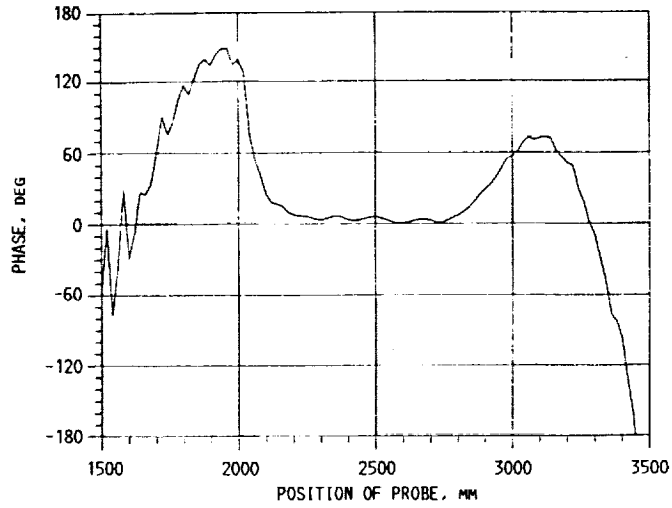

FIGURE 26. - NEAR-FIELD PATTERN AT 9 GHz OF THE REFLECTOR ANTENNA AND A VERTICALLY POLARIZED FEED. HORIZONTAL SCAN.



(a) AMPLITUDE PATTERN.



(b) PHASE PATTERN.

FIGURE 27. - NEAR-FIELD PATTERN AT 10 GHz OF THE REFLECTOR ANTENNA AND A VERTICALLY POLARIZED FEED. VERTICAL SCAN.

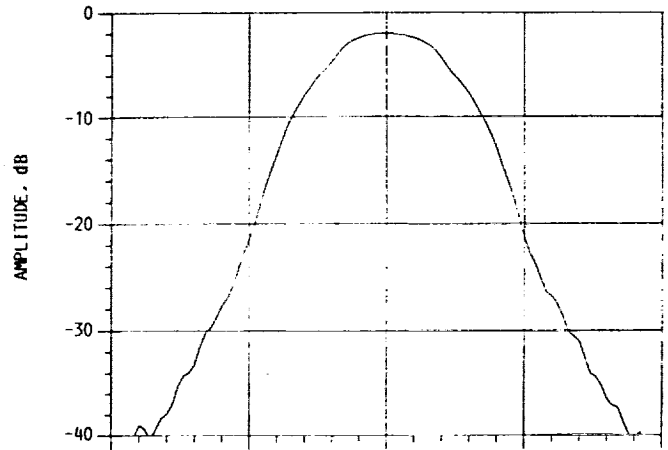

(a) AMPLITUDE PATTERN.

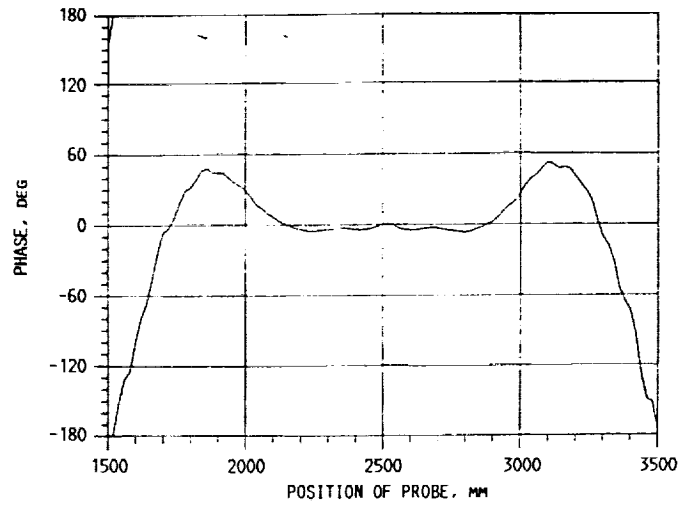

(b) PHASE PATTERN.

FIGURE 28. - NEAR-FIELD PATTERN AT 10 GHz OF THE REFLECTOR ANTENNA AND A VERTICALLY POLARIZED FEED. HORIZONTAL SCAN.

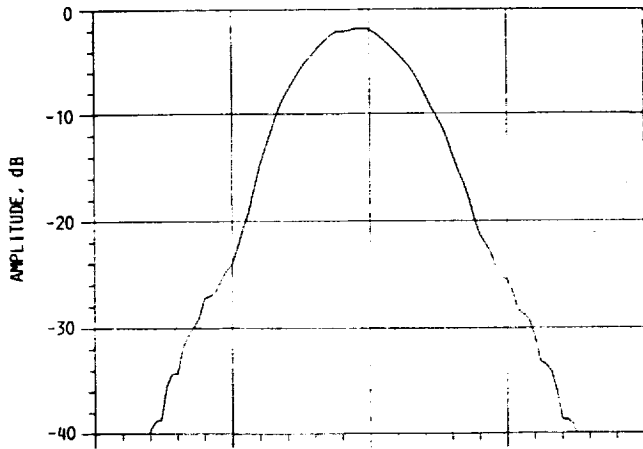

(a) AMPLITUDE PATTERN.

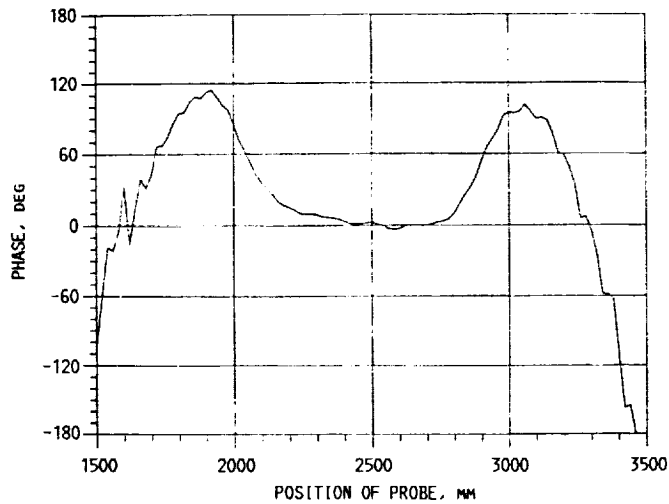

(b) PHASE PATTERN.

FIGURE 29. - NEAR-FIELD PATTERN AT 11 GHz OF THE REFLECTOR ANTENNA AND A VERTICALLY POLARIZED FEED. VERTICAL SCAN.

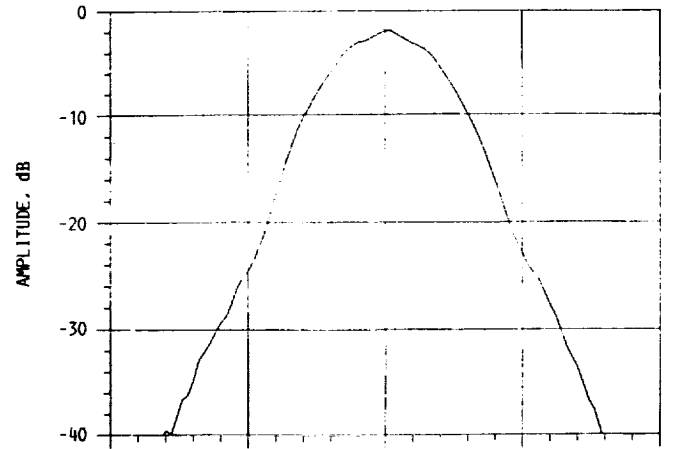

(a) AMPLITUDE PATTERN.

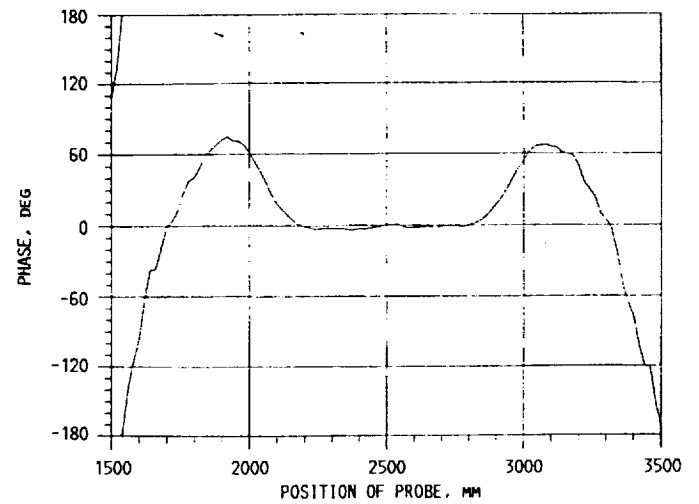

(b) PHASE PATTERN.

FIGURE 30. - NEAR-FIELD PATTERN AT 11 GHz OF THE REFLECTOR ANTENNA AND A VERTICALLY POLARIZED FEED. HORIZONTAL SCAN.

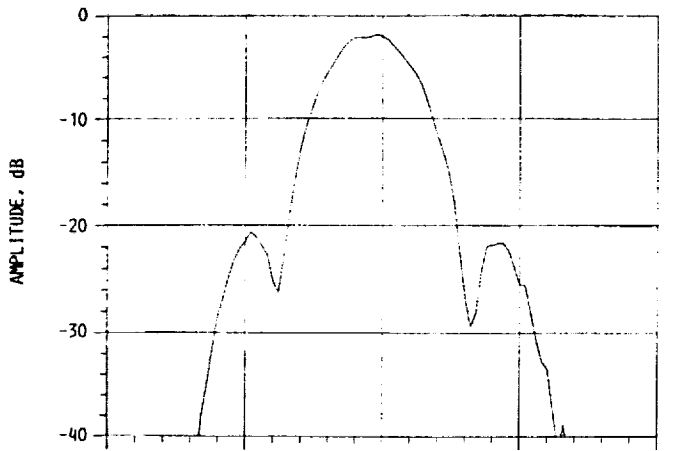

(a) AMPLITUDE PATTERN.

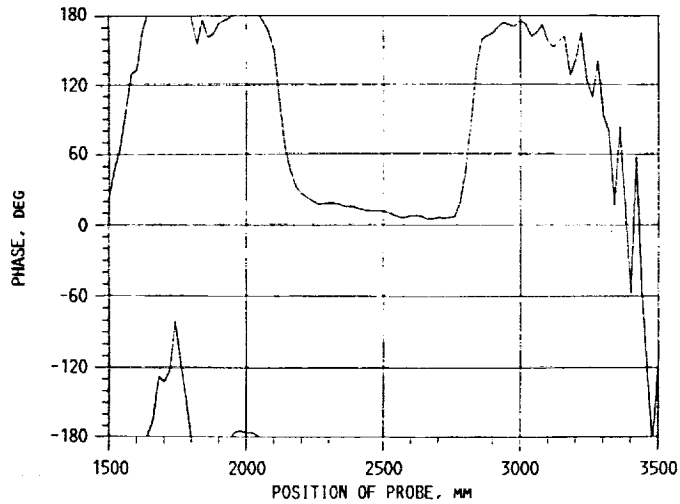

(b) PHASE PATTERN.

FIGURE 31. - NEAR-FIELD PATTERN AT 12 GHz OF THE REFLECTOR ANTENNA AND A VERTICALLY POLARIZED FEED. VERTICAL SCAN.

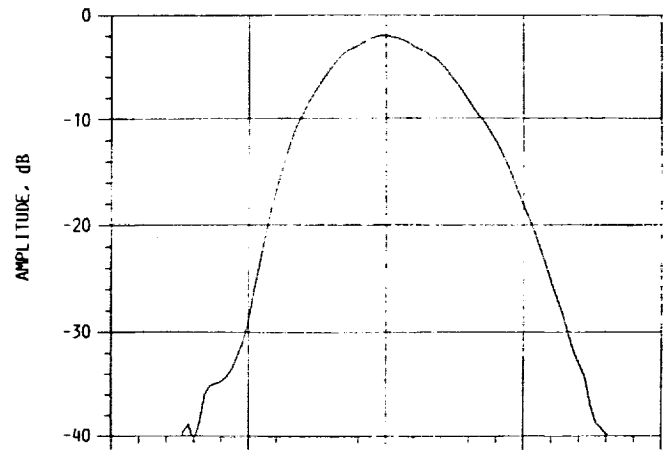

(a) AMPLITUDE PATTERN.

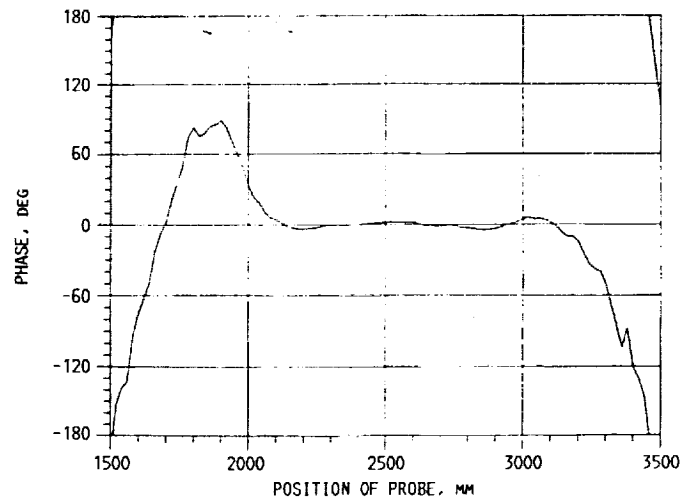

(b) PHASE PATTERN.

FIGURE 32. - NEAR-FIELD PATTERN AT 12 GHz OF THE REFLECTOR ANTENNA AND A VERTICALLY POLARIZED FEED. HORIZONTAL SCAN.

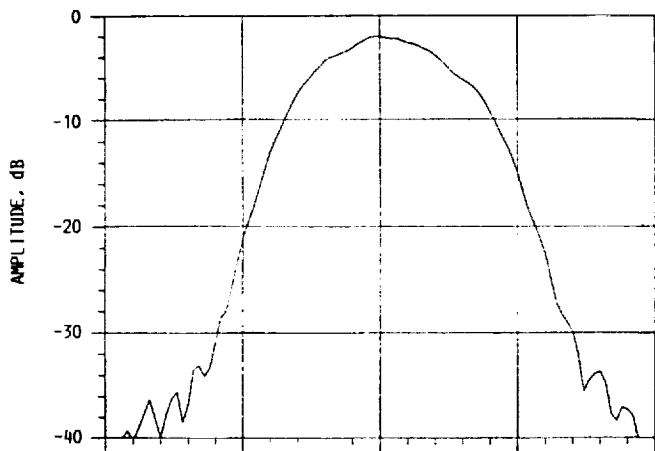

(a) AMPLITUDE PATTERN.

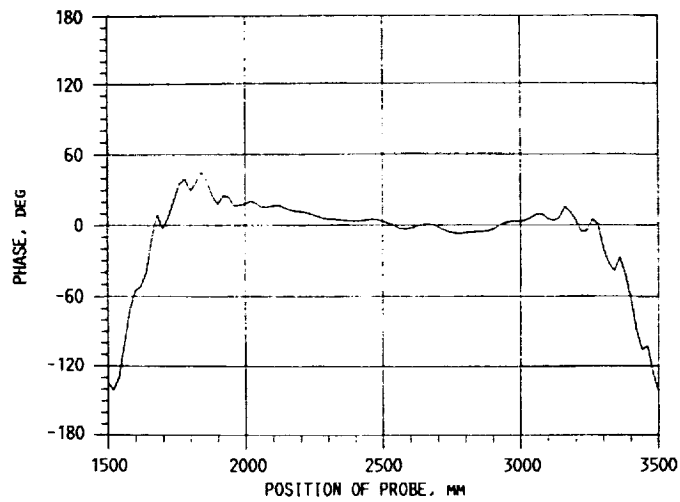

(b) PHASE PATTERN.

FIGURE 33. - NEAR-FIELD PATTERN AT 8 GHz OF THE REFLECTOR ANTENNA AND A HORIZONTALLY POLARIZED FEED. VERTICAL SCAN.

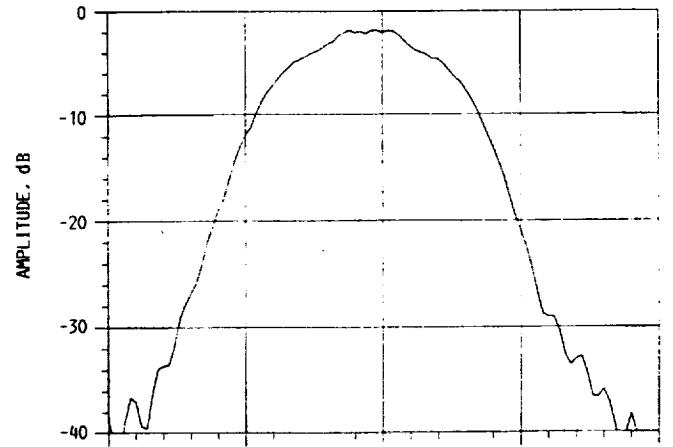

(a) AMPLITUDE PATTERN.

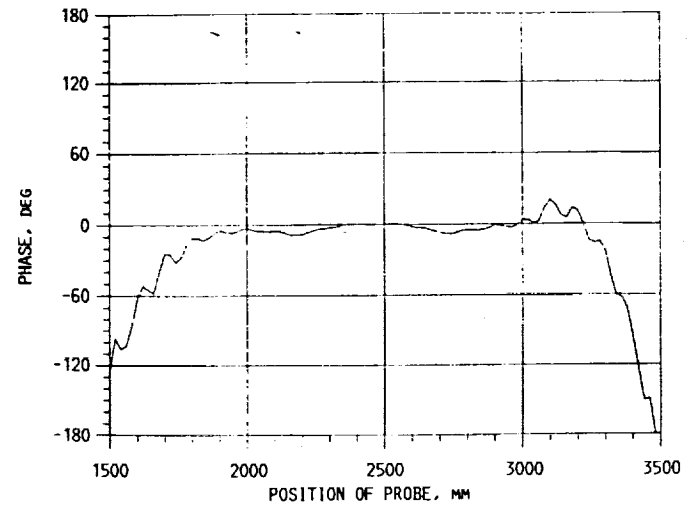

(b) PHASE PATTERN.

FIGURE 34. - NEAR-FIELD PATTERN AT 8 GHz OF THE REFLECTOR ANTENNA AND A HORIZONTALLY POLARIZED FEED. HORIZONTAL SCAN.

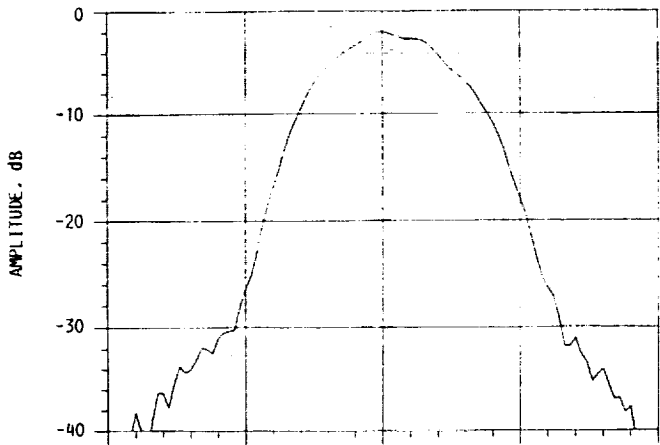

(a) AMPLITUDE PATTERN.

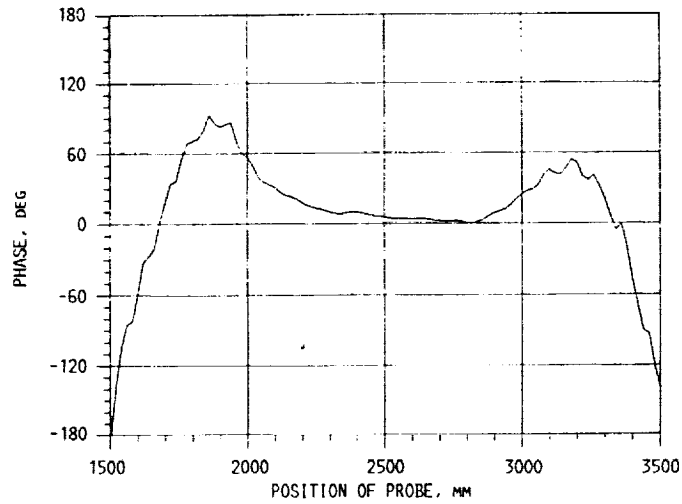

(b) PHASE PATTERN.

FIGURE 35. - NEAR-FIELD PATTERN AT 9 GHz OF THE REFLECTOR ANTENNA AND A HORIZONTALLY POLARIZED FEED. VERTICAL SCAN.

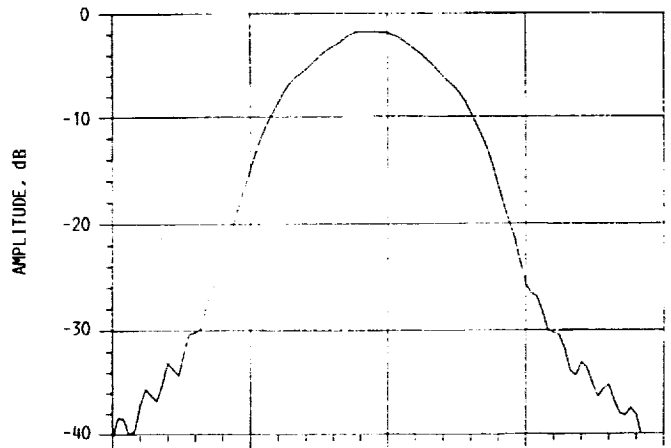

(a) AMPLITUDE PATTERN.

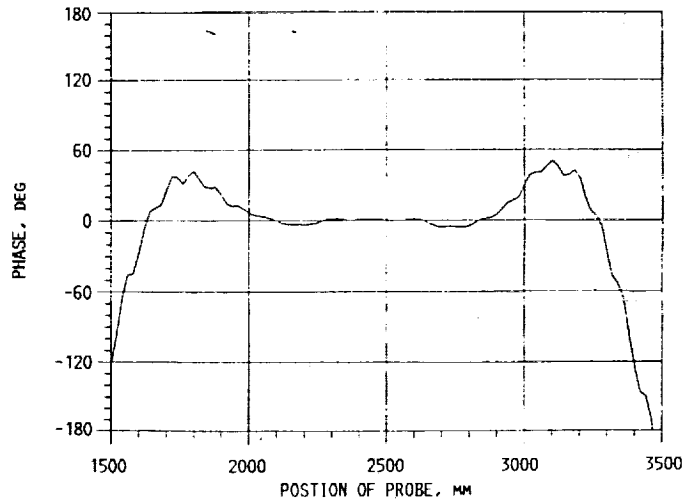

(b) PHASE PATTERN.

FIGURE 36. - NEAR-FIELD PATTERN AT 9 GHz OF THE REFLECTOR ANTENNA AND A HORIZONTALLY POLARIZED FEED. HORIZONTAL SCAN.

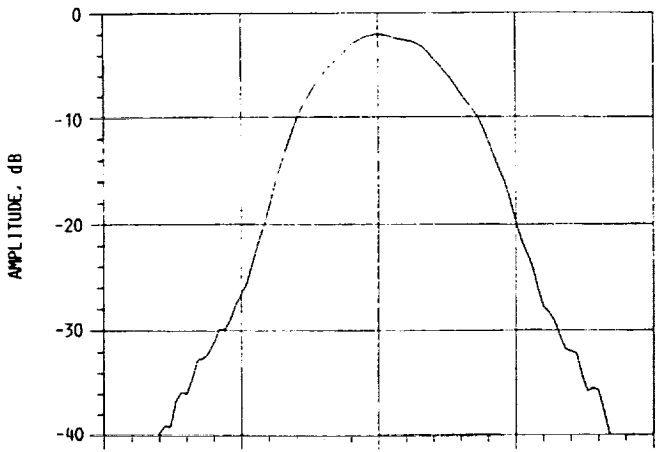

(a) AMPLITUDE PATTERN.

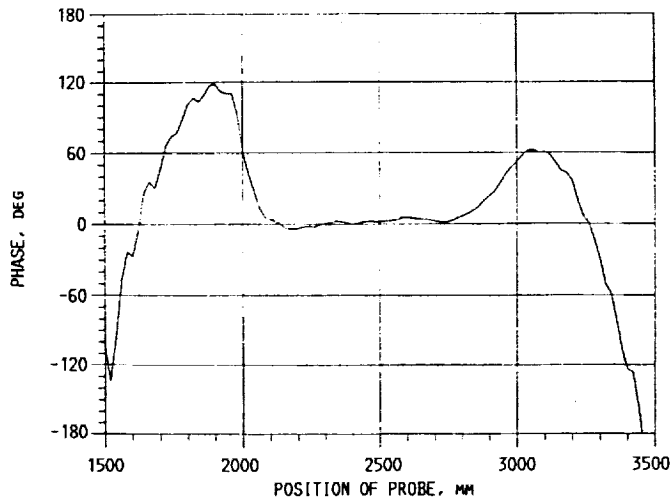

(b) PHASE PATTERN.

FIGURE 37. - NEAR-FIELD PATTERN AT 10 GHz OF THE REFLECTOR ANTENNA AND A HORIZONTALLY POLARIZED FEED. VERTICAL SCAN.

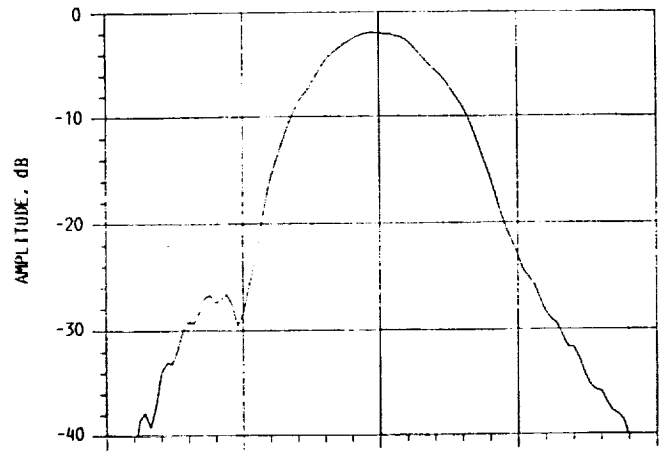

(a) AMPLITUDE PATTERN.

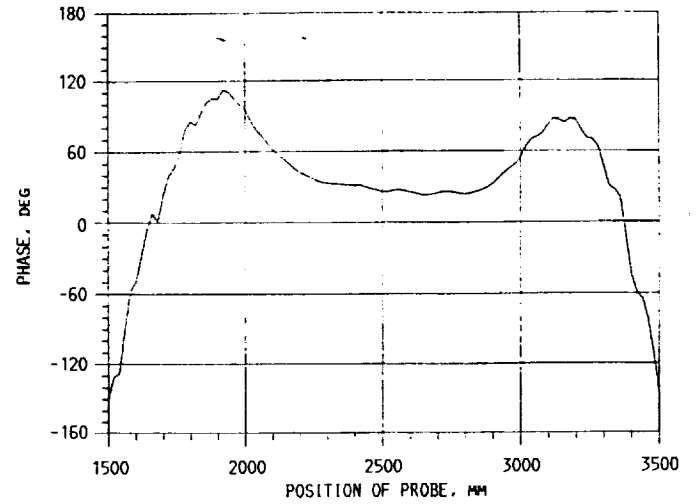

(b) PHASE PATTERN.

FIGURE 38. - NEAR-FIELD PATTERN AT 10 GHz OF THE REFLECTOR ANTENNA AND A HORIZONTALLY POLARIZED FEED. HORIZONTAL SCAN.

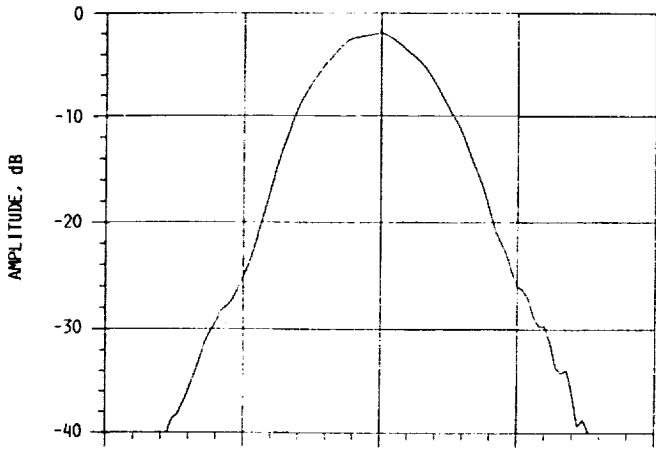

(a) AMPLITUDE PATTERN.

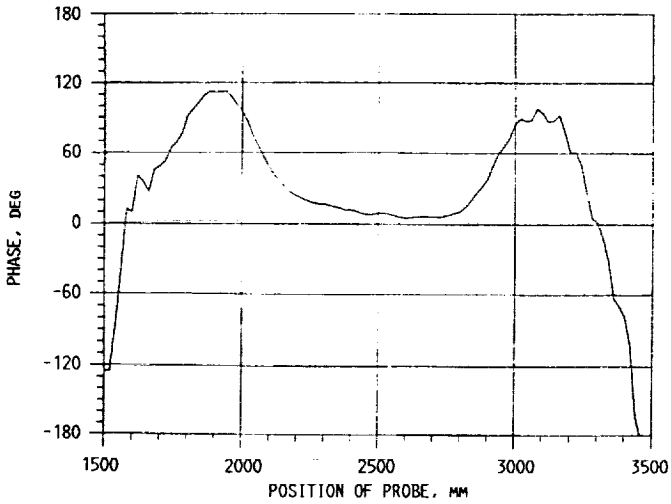

(b) PHASE PATTERN.

FIGURE 39. - NEAR-FIELD PATTERN AT 11 GHz OF THE REFLECTOR ANTENNA AND A HORIZONTALLY POLARIZED FEED. VERTICAL SCAN.

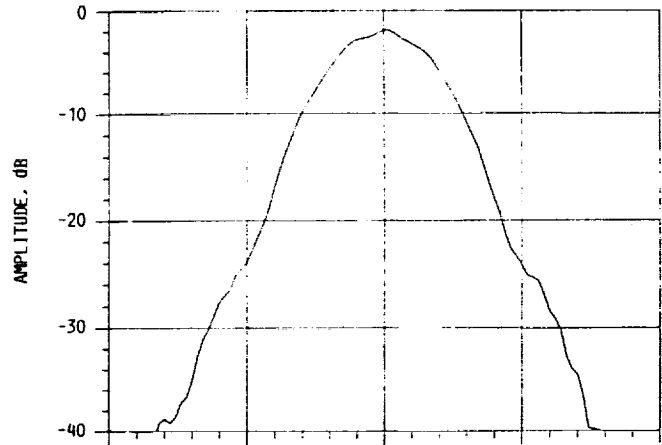

(a) AMPLITUDE PATTERN.

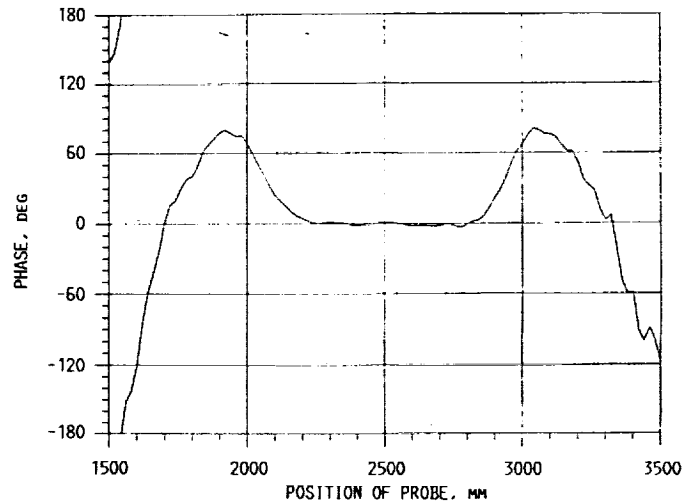

(b) PHASE PATTERN.

FIGURE 40. - NEAR-FIELD PATTERN AT 11 GHz OF THE REFLECTOR ANTENNA AND A HORIZONTALLY POLARIZED FEED. HORIZONTAL SCAN.

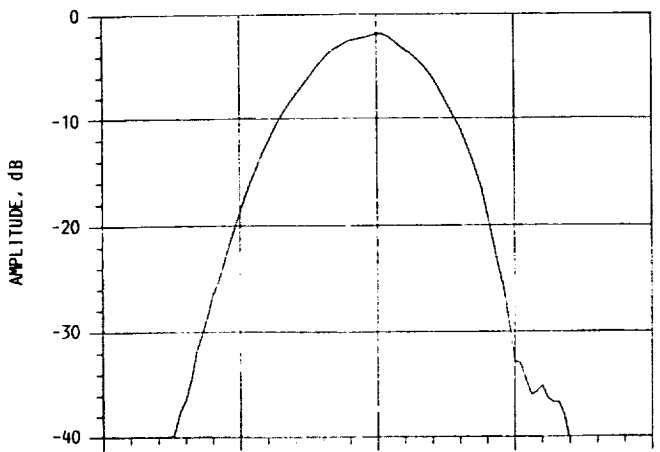

(a) AMPLITUDE PATTERN.

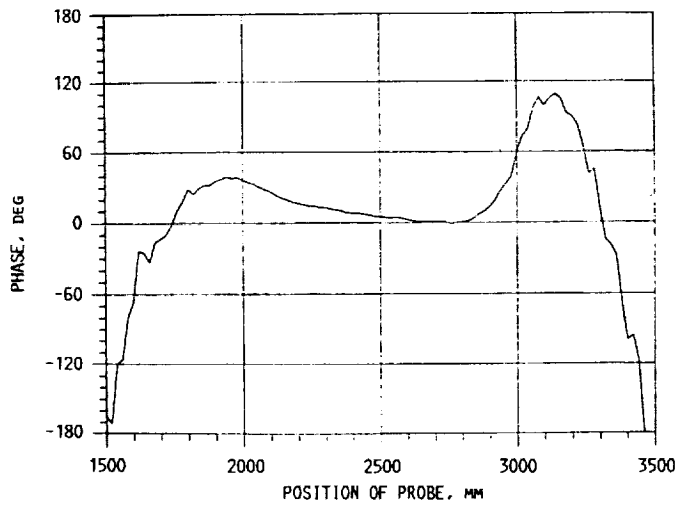

(b) PHASE PATTERN.

FIGURE 41. - NEAR-FIELD PATTERN AT 12 GHz OF THE REFLECTOR ANTENNA AND A HORIZONTALLY POLARIZED FEED. VERTICAL SCAN.

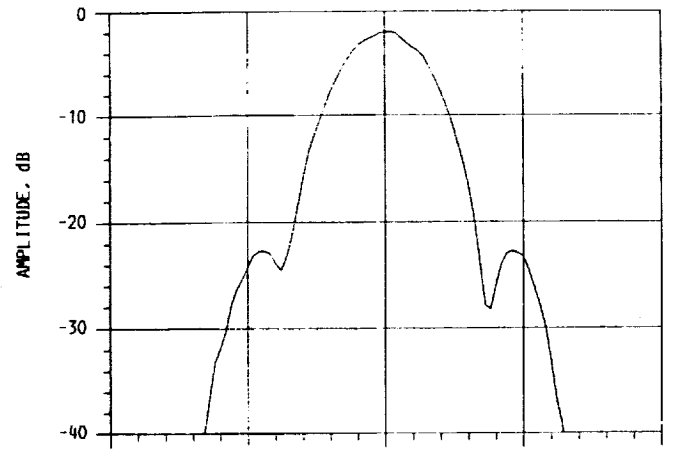

(a) AMPLITUDE PATTERN.

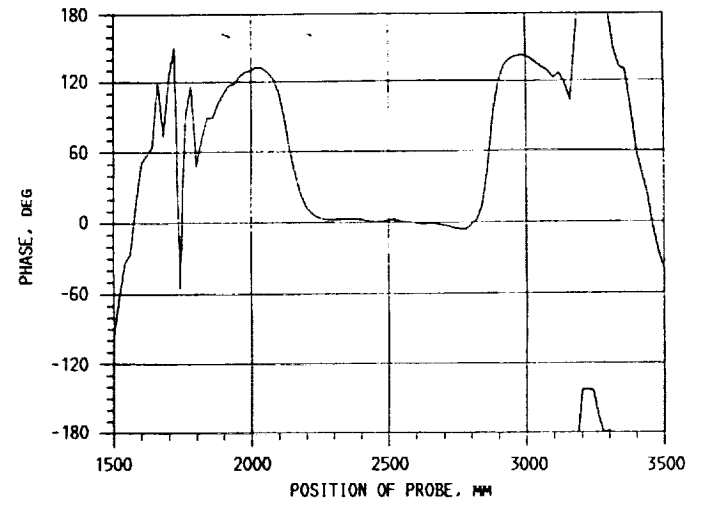

(b) PHASE PATTERN.

FIGURE 42. - NEAR-FIELD PATTERN AT 12 GHz OF THE REFLECTOR ANTENNA AND A HORIZONTALLY POLARIZED FEED. HORIZONTAL SCAN.

1. Report No. NASA CR-187047		2. Government Accession No.		3. Recipient's Catalog No.	
4. Title and Subtitle Measured Performance of the Half-Scale Accurate Antenna Reflector				5. Report Date December 1990	
				6. Performing Organization Code	
7. Author(s) Kevin M. Lambert				8. Performing Organization Report No. None (E-5886)	
				10. Work Unit No. 650-60-20	
9. Performing Organization Name and Address Analex Corporation 21775 Brookpark Road Fairview Park, Ohio 44126				11. Contract or Grant No. NAS3-25776	
				13. Type of Report and Period Covered Contractor Report Final	
12. Sponsoring Agency Name and Address National Aeronautics and Space Administration Lewis Research Center Cleveland, Ohio 44135-3191				14. Sponsoring Agency Code	
15. Supplementary Notes Project Manager, Charles A. Raquet, Space Electronics Division, NASA Lewis Research Center.					
16. Abstract A corrugated horn has been designed and fabricated for use as a feed for the half-scale accurate antenna reflector. This feed allows the reflector to be used in a compact range configuration as part of a microwave reflectance measurement system. This report describes the horn design and presents the measured farfield patterns of the horn. The horn was installed at the focus of the reflector and the near-field of the antenna was measured. The results of these measurements are presented and discussed with respect to the compact range application.					
17. Key Words (Suggested by Author(s)) Reflector antennas Near-field measurements			18. Distribution Statement Unclassified - Unlimited Subject Category 33		
19. Security Classif. (of this report) Unclassified		20. Security Classif. (of this page) Unclassified		21. No. of pages 28	22. Price* A03