

INTERNATIONAL SERIES ON
APPLIED SYSTEMS ANALYSIS



CONFLICTING OBJECTIVES IN DECISIONS

Edited by

DAVID E. BELL

RALPH L. KEENEY

HOWARD RAIFFA

International Institute for
Applied Systems Analysis

CONFLICTING OBJECTIVES IN DECISIONS

Edited by

David E. Bell

Churchill College, University of Cambridge

Ralph L. Keeney

Woodward-Clyde Consultants, San Francisco

Howard Raiffa

*John F. Kennedy School of Government
Harvard University*

This book deals with quantitative approaches to making decisions when conflicting objectives are present. This problem is central to many applications of decision analysis, policy analysis, operational research, etc. in a wide range of fields, for example, business, economics, engineering, psychology, and planning. The book surveys different approaches to the same problem area and each approach is discussed in considerable detail so that the coverage of the book is both broad and deep.

The problem of conflicting objectives is of paramount importance, in both planned and market economies, and this book represents a cross-cultural mixture of approaches from many countries to the same class of problem.

Contents

PART ONE: METHODOLOGY

- 1 Multicriterion Decision Problems
V.M. Ozernoi and M.G. Gaft
- 2 Partial Preference Analysis and Decision-Aid:
The Fuzzy Outranking Relation Concept
B. Roy
- 3 A Research Project on Multicriterion Decision
Making
J. Wallenius and S. Zionts
- 4 Use of Vector Optimization in Multiobjective
Decision Making
M. Peschel and C. Reidel
- 5 Trade-off Analysis: The Indifference and the
Preferred Proportions Approaches
*Kenneth R. MacCrimmon and Donald A.
Wehrung*

(contents continued on back flap)

1 International Series on
Applied Systems Analysis

Conflicting Objectives in Decisions

Edited by

David E. Bell
*Churchill College,
University of Cambridge*

Ralph L. Keeney
*Woodward-Clyde Consultants,
San Francisco*

Howard Raiffa
*John F. Kennedy School of Government,
Harvard University*

*A Wiley-Interscience Publication
International Institute for Applied Systems Analysis*

JOHN WILEY & SONS

Chichester – New York – Brisbane – Toronto

Copyright © 1977 International Institute for Applied Systems Analysis.

All rights reserved.

No part of this book may be reproduced by any means, nor transmitted, nor translated into a machine language without the written permission of the publisher.

Library of Congress Cataloging in Publication Data:

Main entry under title:

Conflicting objectives in decisions.

(International series on applied systems analysis)

'A Wiley-Interscience publication.'

An edited version of the proceedings of a workshop on decision making with multiple conflicting objectives which was held at the International Institute for Applied Systems Analysis, Laxenburg, Austria on Oct. 20-24, 1975.

Includes index.

1. Decision-making - Congresses. I. Bell, David E., 1949- II. Keeney, Ralph L., 1944- III. Raiffa, Howard, 1924- IV. International Institute for Applied Systems Analysis.

T57.95.C65 658.4'03 77-5064

ISBN 0 471 99506 1

Typeset at the Alden Press Oxford London and Northampton
Made and printed in Great Britain at The Pitman Press, Bath

Foreword

This is the initial volume in the International Series on Applied Systems Analysis, sponsored by the International Institute for Applied Systems Analysis (IIASA). The series has been established by IIASA to facilitate the development of systems analysis and encourage its application to problems of international importance. It is intended to serve, like the Institute itself, as a means for the international exchange of information on and experience with systems analysis and as a vehicle for collaboration among scientists and scientific institutions addressing common problems in different countries.

This volume is a particularly appropriate beginning for the series since it addresses a problem on the methodological frontier of systems analysis, which at the same time is of considerable practical importance. Furthermore, it reports work by scientists from more than a dozen nations who were brought together at IIASA for a workshop during October 1975. Finally, it has been edited by the organizers of the workshop, three IIASA staff members, who are now alumni, to provide a broad representation of the state of the art.

Almost all of the issues that decision makers face in actuality involve multiple objectives that conflict in some measure with each other. In such issues, decisions that serve some objectives well will generally satisfy other objectives less well than alternative decisions, which, however, would not be so satisfactory for the first group. The decision maker then must select from among the possible decisions the one that somehow establishes the best mix of outcomes for his multiple conflicting objectives.

The analytical tools developed to aid decision makers facing complex problems originally addressed only single-objective problems. More recently, the artificiality and restrictiveness of that approach for most real problems has led to the development of various methods for handling multiple-objective problems. The purpose of this volume, and of the workshop from which it was derived, is to bring together

and report on these various methods and on their application. As the editors suggest in their preface, better understanding of the processes of decision making with multiple objectives will enable those who must make such decisions to do so more intelligently and thus will enhance the likelihood of good decisions.

The contributors are leading scientists and analysts from government, industry, and the academic world, and their papers (and the informal discussions that follow many of them) should be of interest and use to researchers, analysts, managers, and decision makers throughout the world. The editors have prepared an introductory chapter that provides a background to the papers and places them in context.

We are especially pleased that the first volume in this series is edited by three IIASA alumni – David Bell was with the Institute from 1973 to 1975 and Ralph Keeney from 1974 to 1976; Howard Raiffa was its first director, serving from the founding in 1972 until 1975. We believe that this book makes a distinct contribution to the literature of systems analysis, and we are gratified that IIASA has been able to contribute to its preparation.

JERMEN GVISHIANI
Chairman of the Council

ROGER LEVIEN
Director

Preface

A workshop on Decision Making with Multiple Conflicting Objectives was held at the International Institute for Applied Systems Analysis (IIASA), Laxenburg, Austria, on October 20–24, 1975. Approximately 30 scientists from 15 countries participated. The purposes of the workshop were, among other things,

To review, contrast, and appraise the several basic approaches to decision making in problems with multiple conflicting objectives

To discuss applications involving multiple objectives taken from IIASA projects

To learn of applications involving multiple objectives that have been conducted elsewhere, but that fall within the domain of IIASA projects

This volume contains an edited version of some of the papers presented at the workshop and the discussion that took place.

Why is IIASA interested in the “multiple-objective problem”? The reason is simple. IIASA’s charge is to conduct systematic analyses of problems common to industrialized societies in both the East and the West. Such problems include the use of energy resources, the management of the environment, the development of water resources, and the expansion of regional development. Problems of this type invariably involve multiple conflicting objectives: the decision maker or decision makers must make the vexing value tradeoffs required in such contexts in order to reach a decision. Let us be a bit more concrete.

The energy systems and ecology projects at IIASA are examining the impact of different fuel mixes (e.g., coal, oil, gas, nuclear, solar) on populations of up to approximately 300 million. Different mixes have very different implications for the environmental quality, for human health and safety, for the socioeconomic impact on groups of people, and for the overall system costs. It is important to try to balance these impacts in some way and to come up with the best energy mix, or

at least a good one. Of course, the problem is complicated because the impacts of specific decisions will be felt for many years to come. This implies that another balancing – immediate and short-term impacts versus long-term impacts (perhaps over generations) – must take place.

Our water resources project has been concerned with further development of the Tisza River Basin in Hungary. Each of the distinct alternatives has a constellation of implied impacts related to water availability, floods, recreational potential, employment opportunities, and agriculture, as well as intangible factors such as aesthetics and degree of international cooperation required to make a specific plan feasible. As with similar problems, at the time the decisions must be made, it is impossible to forecast all the possible impacts. Natural factors, such as rainfall, and the complex sociological processes, such as future interest in particular recreational opportunities, contribute greatly to these uncertainties. Yet a decision must be made – now.

An earlier ecology project at IIASA investigated the implications of various strategies for controlling the spruce budworm (a forest pest) in New Brunswick, Canada. Because the lumber industry is very important in this area, serious outbreaks of this pest can be devastating to the economy as well as to the environment. After several iterations, three major objectives were identified. These concerned the recreational value of the forests, the area employment, and the lumber company profits. Simulation models indicated the impact of various strategies on each of these objectives over time, and a multiple-objective time preference model (see Chapter 18 of this volume) was used to evaluate the strategies.

The papers in this volume do cover a variety of approaches to multiple-objective problems. However, the coverage is not at all balanced; there is certainly a concentration of papers in the area of decision analysis. This is due mainly to the fact that our research is in decision analysis, and consequently, we were much more familiar with work, especially with previously unpublished applications, in this area than in others. The coverage is in no way meant to suggest that decision analysis is the “best” approach to all or even most multiple-objective problems or that it is more widely used than other approaches.

Three individuals played major roles in bringing this volume about. Dr. Eva Matt did a marvelous job in making and carrying out all the workshop arrangements. Even though the proverbial phrase says you can’t do it, she seemed to have all the workshop participants pleased all of the time. Ms. Edith Gruber was responsible for typing large segments of the manuscript. It was terrible to read some of that edited material, let alone to type it. After the editing for content, Jeannette Lindsay edited the volume for grammar and consistency, handled design and production, and supervised all the final details necessary to make such a volume a reality. The efforts and contributions of these three individuals are greatly appreciated.

DAVID E. BELL
RALPH L. KEENEY
HOWARD RAIFFA

Contents

Introduction and Overview	1
PART ONE METHODOLOGY	
1 Multicriterion Decision Problems <i>V.M. Ozernoi and M.G. Gaft</i>	17
2 Partial Preference Analysis and Decision-Aid: The Fuzzy Outranking Relation Concept <i>B. Roy</i>	40
3 A Research Project on Multicriterion Decision Making <i>J. Wallenius and S. Zionts</i>	76
4 Use of Vector Optimization in Multiobjective Decision Making <i>M. Peschel and C. Riedel</i>	97
5 Trade-off Analysis: The Indifference and the Preferred Proportions Approaches <i>Kenneth R. MacCrimmon and Donald A. Wehrung</i>	123
6 Conjoint Measurement: A Brief Survey <i>R. Duncan Luce</i>	148
7 Multiattribute Utilities in Expected Utility Theory <i>Peter C. Fishburn</i>	172
8 A Practical Methodology of Solving Multicriterion Problems with Subjective Criteria <i>O.I. Larichev</i>	197
9 On the Elicitation of Preferences: Descriptive and Prescriptive Considerations <i>A. Tversky</i>	209
10 A Dynamic Consumption Model and Optimization of Utility Functionals <i>R. Kulikowski</i>	223
11 State-Dependent Time Preference <i>Richard F. Meyer</i>	232

PART TWO APPLICATIONS		
12	Use of Multiattribute Utility Measurement for Social Decision Making <i>Ward Edwards</i>	247
13	The Use of Decision Analysis in Capital Investment Problems <i>Arnoldo C. Hax and Karl M. Wiig</i>	277
14	Selecting Nuclear Power Plant Sites in the Pacific Northwest Using Decision Analysis <i>Ralph L. Keeney and Keshavan Nair</i>	298
15	A Community Information Feedback System with Multiattribute Utilities <i>Volker Bauer and Michael Wegener</i>	323
16	Multiobjective Decision Making with Applications to Environmental and Urban Design <i>Y. Sawaragi, K. Inoue, and H. Nakayama</i>	358
17	Alternative Formulations for a Trajectory Selection Problem: The Mariner Jupiter/Saturn 1977 Project <i>James S. Dyer and Ralph F. Miles, Jr.</i>	367
18	A Decision Analysis of Objectives for a Forest Pest Problem <i>David E. Bell</i>	389
PART THREE GENERAL DISCUSSION		
19	General Discussion	425
	Participants and Contributors	437
	Index	439

Introduction and Overview

PERSPECTIVES

It is the task of the editors to set the stage and to establish some perspectives. How does the subject matter of this conference on multiple objectives fit into the broader context of *applied systems analysis*? The simplest explanation of what we mean by applied systems analysis can be obtained by a mere rearrangement of the words: the systematic analysis of applied (problems). Such analysis, it is to be hoped, will result in better decisions.

CAN ANALYTICAL THINKING HELP?

Not all problems can benefit from deep, reflective analysis. However, it is the feeling of many practitioners and investigators that the body of material that is now being developed, by many contributors in many fields, under the heading of “multiple objectives,” will become an integral part of the know-how of systems analysts and that this increment of knowledge will help make an even wider class of problems amenable to systematic analysis.

Should formal analysis of a problem be done? Although it may seem platitudinous, it is nevertheless important to say that it depends on the problem, on the analyst – on his personality as well as his skills – on the decision maker(s), and on the sociology of their interaction. It is true that the mere introduction of an analyst and the decision to analyze may already have a biasing effect on the outcome – we could consider whether analysis should be done to do an analysis, and so on. Certainly empirical evidence is important, but many critical issues still defy scientific analysis now and probably will continue to do so.

PREANALYSIS

Preanalysis usually begins when the existence of a problem or a constellation of interrelated problems is recognized. Since the world is complicated and almost everything interacts with everything else, there is a natural desire to include everything in the domain of the problem. In many cases, however, the more extensive a study becomes, the more superficial it becomes; there is a need for an artful compromise between depth of coverage and making the problem easy enough to analyze.

After the decision maker(s) and analyst(s) become aware of the problem and bound its extent, it is important to understand the sociology of the decision problem. Who is the decision maker? Who will be impacted? When? How? Should those affected have a voice in the decision? One must also worry about the decision-making process itself. Which decisions should be made centrally? Which decentrally?

Now let's suppose that we, acting as the decision-making entity, have properly identified our problem, have bounded it, and have examined the sociological structure of the decision environment. Next we must be imaginative, but realistic, about our options. What are our alternatives? What must be decided now, and what can be deferred without loss? What later actions can be made conditional on the outcomes of what intervening events? One must recall that doing nothing is often, in an action sense, doing something. And doing some particular thing tomorrow may be different from doing that same thing today. The creative generation of alternative actions is critically important, and one can find empirical documentation of two strikingly different conclusions: (a) formal analysis often impedes imagination; and (b) formal analysis can help trigger imagination. Of course, we aspire to make the latter conclusion more prevalent. By examining the deficiencies of various action proposals, the analyst can often help tailor-make alternative proposals that will eliminate these deficiencies. Ideally, there should be vigorous interaction between the analysis of proposals and the design of proposals to be analyzed.

MODELING THE CONSEQUENCES OF ACTIONS

Next, the analyst must begin to understand the implications of various courses of action. Not only must he predict the obvious immediate consequences, but he must understand how secondary and tertiary effects reverberate in a dynamic way through a highly interdependent system. This may entail building various models of the system. But before the analyst goes very far in this modeling effort, he must decide what he should be worrying about. What are the outputs? What are the attributes of concern? It is this phase of the problem with which we shall be primarily concerned in this volume. But before describing these concerns, let us round out the picture.

Assume the analyst has now identified and bounded his problem, has examined the sociology of the decision-making setting, has generated alternative options

to be examined and evaluated, has listed the attributes and objectives of concern, has modeled the dynamics of interacting forces at play, and has validated the model with empirical observations; now, at last, the decision maker must decide what best action to adopt. We again come to a phase of the problem of primary interest in this volume – how should the decision maker balance the set of multiple conflicting objectives, especially when those objectives range over such diverse realms as economics, the environment, and health. This is the problem at issue here.

MULTIPLE ATTRIBUTES: THE BASIC PROBLEM

Let us consider a simple abstraction to establish a framework that can then be further embellished. A decision has to be made. The action options are $A_1, \dots, A_i, \dots, A_m$. There are a set of attributes of concern $X_1, \dots, X_j, \dots, X_n$, and each option can be evaluated on each of these attributes. To retain simplicity, let the evaluation of A_i on attribute X_j be given by the single number x_{ij} for $i = 1, \dots, m$ and $j = 1, \dots, n$. Thus, act A_i can be identified with a vector consequence $x_i = (x_{i1}, \dots, x_{ij}, \dots, x_{in})$, and a comparison between two acts involves comparisons between two n -tuples. Now we are ready to look more systematically at some facets of the problem.

Generation of relevant attributes. These are not given *a priori* but must be generated by the analytical team. One desires the attributes to be relevant, inclusive, nonoverlapping, and operational. Furthermore, the set of attributes will not, in general, be unique, and the selection of an attribute set cannot be separated from what is to be done with that attribute set in the ensuing course of analysis.

Incommensurable units. To understand the problem fully, one must always keep in mind that we are dealing with incommensurable quantities. The units of one attribute may be dollars (or schillings or rubles) and those of another may be lives, or levels of pollution.

Intangibles. Some attributes might reflect psychological aspects such as aesthetic considerations, pain and suffering, anxiety, and other intangible qualities. The evaluation of actions on such attributes involves delicate problems of psychological scaling. To ignore such attributes might seriously distort an analysis.

Time. In dynamic models, consequences unfold over time. It is common to look at monetary flows over time and to realize that a monetary unit t years hence should not be treated like the same monetary unit today. We must deal not only with monetary flows over time but with other flows as well. Should we discount lives or ecological indices? If one is concerned with really long-range planning (e.g., nuclear energy options) one might be compelled to think about *intergenerational* as well as other temporal (but *intragenerational*) trade-offs.

Uncertainties. In most applied problems one is uncertain about many things. In particular, the evaluation of act A_i on attribute X_j , called x_{ij} , may be an uncertain quantity. If these uncertainties are acknowledged and probabilities are introduced, then the outcome of an act A_i is a multivariate probability distribution in the n -dimensional attribute space. If time is also included, then the evaluation is in terms of a multivariate stochastic process.

The group welfare problem. Some decisions will benefit some groups and hurt other groups. Hence in any meticulous accounting of consequences, one must consider the distributional impact of decisions. Who is to be advantaged and who disadvantaged? In comparing alternative decisions, one is forced to consider problems of equity. A decision maker whose actions will affect the lives of others must pay attention to the feelings of those others, and he may be forced to make painful, vexing interpersonal and intergroup trade-offs.

This is what the multiple-objective problem is all about: the making of vexing value trade-offs. There is no magic formula for making these value trade-offs. The decision maker would, of course, like to do the best he can in each attribute, but it is not possible to maximize several things at once. If we reduce unemployment, it may be at the expense of increasing inflation; if we cut costs, we usually cut benefits as well; if we control one type of error, it is often at the expense of increasing another type of error.

These problems are pervasive and are at the heart of many public policy controversies. In capitalist countries many of these value trade-offs are made by market mechanisms – sometimes efficiently, sometimes inefficiently. Many public policy problems involve externalities that cannot be internalized by a pricing system. There are other cases in which market imperfections lead to socially undesirable solutions. In socialist economies, which depend less on market mechanisms, these problems are handled by planning agencies. Someone must decide what is in the best interest of society as a whole, and value trade-offs are crucial in such decisions.

VARIOUS APPROACHES

Although the literature on decisions with multiple objectives has shown exponential growth in recent years, it has a long tradition, especially if one considers special aspects of the problem, such as the group (or social) welfare problem or the time problem. In this section we discuss various approaches to the problem of multiple objectives from the vantage point of different disciplines. This should assist the reader in placing specific papers in this volume in a broader perspective.

THE MATHEMATICAL ECONOMICS APPROACH

The literature is vast (e.g., Allen, 1961; Henderson and Quandt, 1958; and Lancaster, 1968), but because of limited space, only two of the most important problems of mathematical economics that bear directly on our subject of concern are discussed.

The Individual as a Rational Maximizer

In the theory of consumer behavior, an idealized economic man is confronted with a choice between bundles of goods and commodities. A commodity bundle can be identified with a vector $x = (x_1, \dots, x_i, \dots, x_n)$, where x_i might be the number of apples to be consumed and x_j the number of oranges. It is usually assumed that idealized economic man has a transitive preference ordering over bundles and that this is consistent with a (real-valued) utility¹ function u , where $u(x)$ denotes the utility (desirability) of bundle x . Pareto and others have shown that the essential ingredient of the logical superstructure of economics is not the utility function but rather the structure of the n -dimensional isopreference curves. Relatively little attention in economics has been given to practical studies that either try to ascertain isopreference structures or try to determine appropriate utility functions (Debreu, 1960). Utility ideas are used primarily as a theoretical construct to describe idealized behavior rather than as aids to *guide* behavior.

The theory is designed primarily to permit qualitative conclusions about the descriptive behavior of consumers as a group and to use these insights in the theory of the firm or in general equilibrium theory (e.g., what happens to supply and demand if certain taxes or regulations are imposed).

Very little has been done to enlarge the scope of the problem to include uncertainties except, of course, to observe that if probabilistic choice is involved, then the utility function must be further constrained to be cardinal (as opposed to ordinal) and the von Neumann–Morgenstern (or Ramsey) theory must apply (Arrow, 1965; von Neumann and Morgenstern, 1947; Ramsey, 1931).

The Social Welfare Function

If x is a commodity bundle shared by n members of the society, then one often posits the assumption that the i th individual $i = 1, 2, \dots, n$ has a preference function $u_i(x)$ and the group utility function (or social welfare function) is of the form

$$u^*(x) = f[u_1(x), u_2(x), \dots, u_n(x)],$$

which is often taken to be additive:

¹ This utility function is more precisely called an ordinal utility function. Its only strategic purpose is to yield ordinal rankings between x -bundles.

$$u^*(x) = \sum_{i=1}^n \lambda_i u_i(x).$$

There is a rich literature on this problem that quickly becomes embroiled in questions of interpersonal comparisons of utilities. For the most part this literature concentrates on the certainty domain. Some of the literature (Nash, 1950; Harsanyi, 1956; Luce and Raiffa, 1957) extends these ideas to probabilistic choice situations, but once again the literature theorizes about idealized behavior and little attempt has been made to assess actual utility functions and to use these to guide behavior.

THE PSYCHOMETRIC APPROACH

Psychometricians have long been fascinated with the problem of multidimensional scaling. Their orientation is to find some simple, psychologically appealing, latent (genotypic) model that can account for the manifest (phenotypic) behavior of individuals. Factor analysis and multidimensional scaling models are examples of such models. A tie between this tradition and the tradition of the mathematical economist can be found in the work of Luce and Tukey (1964) on conjoint measurement. Once again, the orientation and motivation is to explain, rationalize, understand, and predict behavior – not to guide it.

There is a vast literature on behavioral decision theory [see the review article by Hogarth (1975)] that examines individual behavior under conditions of certainty, risk, and uncertainty. Most of the researchers are mathematical psychologists and psychometricians, and their orientation is to try to understand behavior better in order to be in a better position to (a) predict (descriptive) behavior and (b) guide (prescriptive) behavior. The empirical research of the psychological school of behavioral decision theorists includes laboratory experiments and observations of natural behavior.

THE MATHEMATICAL OPTIMIZATION APPROACH

The Standard Problem

The basic problem of mathematical programming or control theory can be abstracted in the following terms: Let Z be a set of control or decision variables with generic element z [for example, in linear or nonlinear programming z may be an n -tuple, but more generally z may be a function over some (infinite dimensional) space]. The set of permissible or feasible z 's is restricted by a set of constraints (e.g., by a set of linear or nonlinear inequalities). Let the set of *feasible* z 's that satisfy these constraints be denoted Z_0 . In the classical formulation of the programming problem one assumes the existence of a single objective function that associates to each feasible z in Z_0 a numerically scaled evaluation $X(z)$; in linear programming where z is an n -tuple, $X(z)$ is a linear function $\sum_i c_i z_i$. The problem is now formulated: find z^0 in Z_0 to maximize (or minimize) $X(z)$. Constraints are

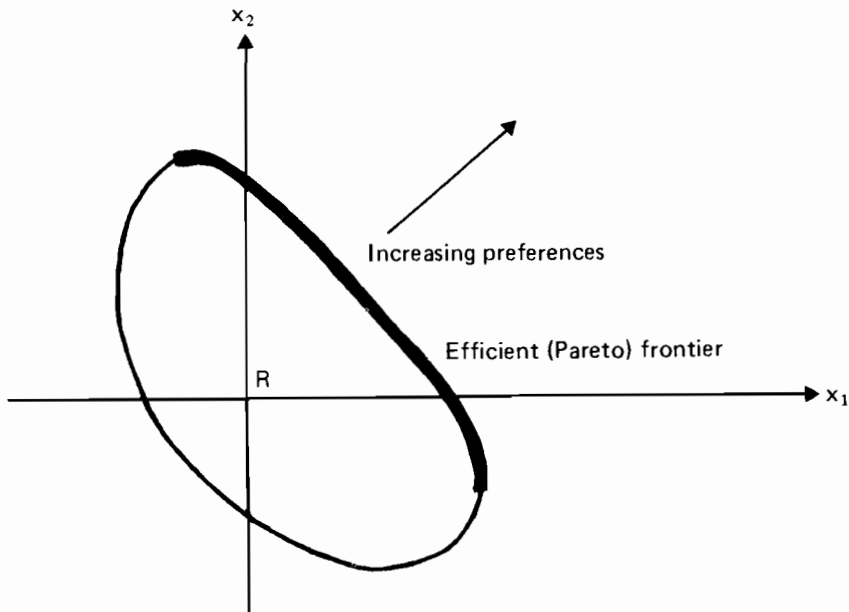

FIGURE 1 Set of attainable evaluations.

used as a way of eliminating alternatives that are known in advance to be non-optimal, and in this way a simple objective function may be a close enough representation of the “true” multiple objective trade-offs in the feasible domain.

The Multiobjective Generalization

Instead of a single objective function, let us now consider n objective functions X_1, \dots, X_n . For each feasible z in Z_0 we now associate a vector evaluation

$$X(z) = [X_1(z), \dots, X_i(z), \dots, X_n(z)].$$

We cannot generally choose z to maximize $X_i(z)$ for all i .

Several problems have received attention in this literature:

Problem A (characterization of multidimensional opportunities). Let R be the set of points in n -space of the form $X(z)$ for all z in the feasible domain Z_0 (Figure 1). One asks: Is the set R convex? How can one characterize the efficient (Pareto) frontier of nonstrictly dominated points?

Problem B (setting of aspiration levels: goal programming). For each evaluator X_i , a goal value b_i is tentatively proposed, and the analyst investigates the possibility of finding a z in Z_0 that simultaneously satisfies the extra n inequalities

$$X_i(z) \geq b_i, \quad i = 1, 2, \dots, n.$$

The goal vector b may then be successively changed through informal, interactive exchanges among analyst, programmer, and decision maker (Dyer, 1972; Kornbluth, 1973).

Problem C (interactive exploration of the efficiency frontier). We can introduce an auxiliary problem: find z in Z_0 that maximizes $\sum_i \lambda_i X_i(z)$ for a set of externally suggested weights $\lambda_i \geq 0$ ($i = 1, \dots, n$) and $\sum_i \lambda_i = 1$. The resulting optimal z (which depends on λ) will yield a point on the efficient frontier together with marginal substitution rates for this frontier point. The decision maker can now decide which way to move (if at all) on this frontier. This is often done informally, and there is an active interchange between probing the decision maker's preferences and the attainability of evaluation outcomes. Usually, no attempt is made to investigate the basic structure of the decision maker's preferences. This is left unformalized.

Problem D (introduction of an ad hoc aggregation function). An illustration will help to explain what is done here. Let $x_i^* \equiv \max_{z \in Z_0} [X_i(z)]$; that is, x_i^* is the best that could be done if X_i were the only objective function. Let $x^* = (x_1^*, \dots, x_n^*)$; we can think of x^* as the unattainable aspiration point. Introduce a norm $\|x - x^*\|$ that measures the distance from x to x^* , and now the problem is formulated: choose z in Z_0 to minimize $\|X(z) - x^*\|$; i.e., choose a feasible z whose vector evaluation comes closest to the unattainable x^* .

This procedure, although mathematically satisfying, is not operational until one decides on the norm to be used. In illustrative problems, one often introduces the mathematically convenient norm, $[\sum_i \lambda_i (x_i - x_i^*)^2]^{1/2}$; but one must then grapple with the all-important λ weights.

In all these problems, uncertainty is not handled except perhaps by deterministic sensitivity studies.

THE COST-EFFECTIVENESS AND COST-BENEFIT APPROACH

In cost-effectiveness analyses, distinct from cost-benefit analyses, a proposal q is usually evaluated in terms of several cost indices $c_1(q), \dots, c_s(q)$ and several benefit indices $b_1(q), \dots, b_r(q)$. Although a monetary unit to one government agency is not the same as to another agency or to a private company, and although a monetary cost today is different from the same cost in t years, these costs $c_1(q), \dots, c_s(q)$ are in sufficiently commensurable units that one usually collapses the costs into an overall single cost, say $c^*(q)$.

Collapsing the benefit side is more difficult and therefore more controversial (Mishan, 1972; Peskin and Seskin, 1973). In cost-effectiveness analysis, the different types of benefits are kept separate. One classical problem is to set aspiration

levels b_1^*, \dots, b_r^* and to find the program q^0 that satisfies these aspirations – viz, $b_i(q^0) \geq b_i^*$, all i – and that minimizes $c^*(q)$. An analytical staff might prepare for policy consideration several sets of target levels (b_1^*, \dots, b_r^*) each with its associated minimum cost figure.

In cost–*benefit* analysis – or, as some might prefer to say, in benefit–cost analysis – there is an attempt to collapse the r benefits $b_1(q), \dots, b_r(q)$ associated with proposal q into an overall benefit index $b^*(q)$. Now if an agency has many proposals and an overall budget constraint \bar{c} , proposal q should be ranked alongside other projects by its benefit–cost ratio $b^*(q)/c^*(q)$, and projects should be accepted from the top of the list until the total budget \bar{c} is exhausted. This can be shown to be optimal, except for indivisibility effects, which in many circumstances are minor.

The weakest link in this development is the collapsing of the benefits $b_1(q), \dots, b_r(q)$ into a single composite benefit $b^*(q)$. How can this be done? In most applications of these techniques in market economies, one allows market mechanisms to help make these trade-offs. There are objections, however:

There may be imperfections in the market mechanisms.

There is a tendency not to include benefits that cannot be “priced out” by a market mechanism.

Cost–benefit analysis as well as cost–effectiveness analysis usually ignores uncertainties. Since this is intolerable in some applied contexts (such as studies involving natural hazards), *cost–benefit–risk* analysis should be employed.

The major departure of cost–benefit–risk analysis from the traditional cost–benefit analysis is the explicit introduction of uncertainties. Probabilities (or risks) of various possible events are specified. However, in the overall evaluation process, the impacts of these possible events are usually collapsed by using an expected impact on each attribute. The decision criterion often used is to maximize the benefit–cost ratio with the restriction that the risk should not exceed an acceptable level. Of course, identifying this acceptable level requires someone to make some difficult value judgments.

Most cost–benefit analyses of any type leave out one crucial matter: the ability to adapt or adjust a strategy to account for information acquired along the way. The *dynamics* of uncertainty analysis (i.e., how assessments of uncertainties might evolve over time) are especially important in problems with long time horizons.

THE DECISION ANALYSIS APPROACH

The aim of decision analysis is to decompose a problem into two parts: one to indicate the probabilities of different possible consequences of each alternative and the other to evaluate the desirability of those possible consequences.

The consequences are evaluated using a von Neumann–Morgenstern utility function u that assigns a utility $u(x_i)$ to consequence x_i . The key property of this function is that it is appropriate to evaluate alternatives using their expected utilities; better alternatives have higher expected utilities.

The probabilities $p_i(x_i)$ associating the likelihood of an actual consequence x_i given an alternative A_i may be assessed objectively (if possible) or subjectively by the decision maker or some other more qualified expert.

The assessment of the utility function by questioning the decision maker is intended to involve much less complex trade-offs than the real problem does. The spirit of recent theoretical work in decision analysis has been to find ways of identifying simple underlying preference structures that enable the analyst to break down the assessment of a multidimensional function into that of several one-dimensional functions (Fishburn, 1970; and Keeney and Raiffa, 1976).

ORGANIZATION OF THE VOLUME

We have chosen to place the papers in this volume in two categories, those concerned mainly with methodological aspects of multiple-objective problems and those concerned mainly with applications. Papers that focus on procedures for using methodological tools are included under the heading of methodology. At the end of the book, there is a condensation of some of the general discussion that took place at the workshop.

METHODOLOGY

Each of the first four papers is concerned with models that attempt to examine the alternatives and specify either the best one, or a set of “good” ones, or a ranking. Hence, both the consequences of each alternative and an indication of the decision maker’s preferences for those consequences are included in each of the models.

The first paper, by Ozernoi and Gaft, suggests a general approach to addressing multiple-objective decision problems under certainty. The focus is on the construction of decision rules consistent with the decision maker’s preferences. The technique employs an iterative procedure in which the decision maker’s preferences are obtained in steps; after each step, alternatives are examined, and dominated ones are dropped from further consideration. This allows one to eliminate alternatives sequentially, beginning with very vague information about the decision maker’s preferences and progressively requiring more precise information. An illustration of the use of this technique for evaluating the design and technological layout of coal mines is presented.

In Chapter 2, Roy wishes to isolate the set of “best” alternatives where the set may be specified as containing one or more alternatives. First, the decision maker is guided through an essentially creative process to identify his true criteria and then

map the implications of each alternative onto those criteria. Next, he is asked to examine pairs of alternatives holistically to construct outranking relationships. These pairs specify whether one alternative is at least as good as another in terms of a given criterion. By examining all the outranking relationships, one identifies inferior alternatives and eliminates them. To address problems in which the decision maker's preferences are not completely known, Roy introduces a "fuzzy outranking" relationship that indicates the degree to which one alternative outranks another. This information on strength of preference aids in ranking the noninferior alternatives.

Zionts and Wallenius describe their iterative procedure for solving multiple-criterion mathematical programming problems in Chapter 3. The method assumes that the decision maker can specify concave objective functions for each objective, but it does not presuppose the formalization of the value trade-offs. Via an interactive computer program, pairs of nondominated alternatives are offered to the decision maker, and he is asked to respond to the proposed choices by choosing the better one or indicating his uncertainty. Subject to consistent preferences, the method converges on a best alternative. Initial experiences with implementation of the model are discussed.

Peschel and Riedel, in Chapter 4, are concerned with identifying the Pareto-optimal set of alternatives — that is, the set of nondominated alternatives. More specifically, the focus is on the class of problems in which control theory can be effectively utilized. Several procedures for selecting the best point from the Pareto-optimal set are suggested, and a number of applications concerning the optimal design of technological devices, such as switching circuits for machine tools, are discussed.

The next three papers differ from the first four in that the overall decision problem is not considered. Rather, these papers focus only on structuring aspects of the preferences of the decision maker. Such information must then be integrated with the consequences of each alternative in order to allow selection among the alternatives.

In Chapter 5, MacCrimmon and Wehrung are concerned with quantifying the value trade-offs of the decision maker. They focus on two representations that do this — indifference curves and preferred proportion curves. Several procedures for eliciting such curves from decision makers are discussed.

Luce surveys conjoint measurement, which is concerned with numerical representations of orderings on Cartesian product sets, in Chapter 6. The emphasis is on decomposable representations of these orderings. In the multiple-objective context, these representations can formalize the decision maker's value structure for consequences under certainty.

Chapter 7, by Fishburn, reviews von Neumann–Morgenstern utility theory. Different independence conditions on consequences or gambles defined on the set of consequences are examined, and special representations of the utility function implied by such conditions are noted. Aspects of verification of the conditions, their applicability, and assessment of the resulting utility function are discussed.

The next two chapters discuss factors that are crucial in applying multiple-objective evaluation procedures. In Chapter 8, Larichev addresses the issue of subjective criteria – that is, criteria requiring the development of a subjective index to indicate degrees of achievement on them. He suggests that an index based on qualitative estimates in terms of verbal descriptions of only a few quality levels seems to work best. An example of the evaluation of R&D projects is discussed briefly.

Tversky writes about the elicitation of preferences in Chapter 9. More specifically, he discusses two phenomena that often bias assessments of utility functions. First, individuals tend to value a specific outcome more if it is certain than if it is uncertain. Second, individuals often evaluate options relative to a reference point, such as the status quo or the aspiration level. These effects are illustrated and their implications discussed.

Chapters 10 and 11 address preferences over time. In Chapter 10, Kulikowski introduces a dynamic consumption model that prescribes how a consumer should utilize financial resources for consumption over time. For a specific consumption model described in the paper, the optimal allocation strategy for resources is derived. In Chapter 11, Meyer introduces the idea of state descriptors to simplify the assessment of preferences for time streams of consequences. Such descriptors allow one to summarize the effect of past experiences on present preferences in terms of a few variables – namely, the levels of those state descriptors. The structure imposed on the utility function when the state descriptors take on certain intuitively appealing properties is derived.

APPLICATIONS

While the seven applications papers do cover a variety of problems involving multiple objectives, not all the various approaches to such problems are represented. Several of the papers discuss the use of decision analysis in a variety of contexts. As indicated in the preface, the reason for this is that our research concentrates on decision analysis, and consequently we were more familiar with applications in this area than in others.

Edwards, in Chapter 12, is concerned with social decision making by groups of individuals with conflicting value structures. He indicates that multiattribute utility measurement, by making explicit each individual's values, can help show how they are different and can frequently result in a reduction of these differences. He describes the application of multiattribute utility measurement in two specific cases, management of the coastal zone in a part of Los Angeles, California, and selection of research programs for the Office of Child Development of the U.S. Department of Health, Education, and Welfare.

In Chapter 13, Hax and Wiig discuss the use of decision analysis for appraising possible capital investment strategies of a major mining company. The company's basic problem was to decide whether to bid on two parcels of land with extensive

ore deposits. The company could bid on either or both parcels with or without a partner. Assuming acquisition of a parcel, production decisions about development and exploitation of the parcel were analyzed. The implications of an analysis with two objectives indicated a different best strategy from that suggested by initial single-objective "dollars and cents" analyses. The decision maker chose to act in accordance with the two-objective analysis.

The evaluation of potential sites for nuclear power facilities in the state of Washington, U.S.A., is discussed by Keeney and Nair in Chapter 14. A series of screening models identified nine specific sites for evaluation. A decision analysis was used for an evaluation of these sites based on six major objectives concerning human health and safety, environmental effects, socioeconomic impacts, and financial considerations.

In Chapter 15, Wegener and Bauer discuss the use of multiattribute utility to assist interested citizens in joining in public planning and decision processes. Specifically, they examine alternative urban development plans with an urban simulation model and an evaluation procedure based on multiattribute utility. Experimental applications of the technique in Darmstadt, a city in the Federal Republic of Germany, are described.

Nakayama, Sawaragi, and Inoue discuss aspects of a large environmental pollution control project in Japan in Chapter 16. They first illustrate the use of the multiplier method for optimization of a class of environmental control problems; the main application concerns the problem of thermal discharge in steam power plants. A second case discussed briefly is that of urban planning, where the intent is to evaluate citizen consciousness of the quality of urban life.

In Chapter 17, Dyer and Miles illustrate the use of various approaches for facilitating the selection of trajectories for spacecraft. Eleven teams of scientists, each with a different set of objectives, were involved in the evaluation of more than thirty pairs of trajectories for two spacecraft scheduled to be launched to Jupiter and Saturn. The overall evaluation process was used in selecting the trajectory pair finally adopted for a 1977 launching.

Bell discusses the application of decision analysis for forest pest management in Chapter 18. A model was developed by the ecology project at IIASA for examining alternatives for combating the spruce budworm, a forest pest, in New Brunswick, Canada. The paper describes the process of articulating the objectives – employment, lumber company profits, and the recreational value of the forest – eventually used in the evaluation process. A utility function was assessed over these attributes that explicitly took into account the long time horizon involved.

CONCLUSION

These papers give a sample of the current approaches being tried in many countries in the hope of improving our ability to analyze complex problems. The variety of

successful applications is encouraging, and, taken together with further examples appearing regularly in the scientific and business literature, suggests that these techniques are finding acceptance among analysts and decision makers.

No one approach will ever be proved to be best in all circumstances. This volume provides extensive coverage for those who wish to become familiar, or more familiar, with the techniques currently available.

REFERENCES

- Allen, R.G.D. 1961. *Mathematical Analysis for Economists*. Addison Wesley, Reading, Massachusetts.
- Arrow, K.J. 1965. *Aspects of the Theory of Risk-Bearing*. Yrjö Jahnssonin Saatio, Helsinki.
- Debreu, G. 1960. Topological methods in cardinal utility theory. In *Mathematical Methods in the Social Sciences, 1959* (K.J. Arrow, S. Karlin, and P. Suppes, eds.). Stanford University Press, Stanford, California.
- Dyer, J.S. 1972. Interactive goal programming. *Management Science*, Vol. 19, pp. 62–70.
- Fishburn, P.C. 1970. *Utility Theory for Decision Making*. Wiley, New York.
- Harsanyi, J.C. 1956. Approaches to the bargaining problem before and after the theory of games: a critical discussion of Zenthen's, Hick's and Nash's theories. *Econometrica*, pp. 144–157.
- Henderson, J.M., and R.E. Quandt. 1958. *Microeconomic Theory*. McGraw-Hill, New York.
- Hogarth, R. 1975. Cognitive processes and the assessment of subjective probability distributions. *Journal of the American Statistical Association*, Vol. 70, pp. 271–289.
- Keeney, R.L., and H. Raiffa. 1976. *Decisions with Multiple Objectives*. Wiley, New York.
- Kornbluth, J.S.H. 1973. A survey of goal programming. *Omega*, Vol. 1, pp. 193–205.
- Lancaster, R. 1968. *Mathematical Economics*. Macmillan, New York.
- Luce, R.D., and H. Raiffa. 1957. *Games and Decisions*. Wiley, New York.
- Luce, R.D., and J.W. Tukey. 1964. Simultaneous conjoint measurement: a new type of fundamental measurement. *Journal of Mathematical Psychology*, Vol. 1, pp. 1–27.
- Mishan, E.J. 1972. *Economics for Social Decisions: Elements of Cost-Benefit Analysis*. Praeger, New York.
- Nash, J.F. 1950. The bargaining problem. *Econometrica*, Vol. 18, pp. 155–162.
- Peskin, H.M., and E.P. Seskin. 1973. *Cost-Benefit Analysis and Water Pollution Policy*. The Urban Institute, Washington, D.C.
- Ramsey, F.D. 1931. *The Foundations of Mathematics and Other Logical Essays*. Kegan, London.
- von Neumann, J., and O. Morgenstern. 1947. *Theory of Games and Economic Behavior*. Princeton University Press, Princeton, New Jersey.

Part One

Methodology

1 Multicriterion Decision Problems

V. M. Ozernoi and M. G. Gaft

1.1 INTRODUCTION

A large number of publications devoted to multicriterion decision problems have appeared: the theory, techniques, and practice. Nevertheless, no formalized techniques are available that cover all decision steps from the initial statement of the problem to the choice among alternatives for achieving the desired result. This paper suggests a general approach to multicriterion decision problems under certainty and develops a multicriterion model with the following elements: (a) a statement of the problem, (b) a set of feasible alternatives, (c) a set of criteria, (d) estimating scales, (e) a mapping of the feasible alternatives for the set of vector-valued estimates, (f) the system of preferences of the decision maker, and (g) decision rule. Included are a general-procedure flowchart with formalized and non-formalized steps and a discussion of the construction of all the model's elements and consideration of their correction and updating at subsequent steps. Various possible ways of constructing these elements are analyzed, and guidelines are given for those steps in the model's construction that cannot be formalized.

The major focuses of attention are on the establishment of decision rules and on the decision maker's preference system, largely because most difficulties that arise in developing and using multicriterion models can be attributed to these sources. The technique suggested is an iterative procedure in which data on the decision maker's preferences are obtained in steps. The information obtained at each step is used to form a new decision rule more informative than the previous one. Thus, the sequence of decision rules is ensured: the initial decision rule, which is weakest of all, uses the simplest information and most evident assumptions; all subsequent decision rules are obtained from previous ones and incorporate additional assumptions consistent with those accepted earlier and with the additional information.

The formal properties of these decision rules are investigated, with emphasis on

meaningfulness and on consistent criteria for obtaining useful information for the decision maker. A classification system is developed to define the sequence for obtaining various types of information according to the decision maker's preferences.

The approach suggested here has been repeatedly used for the solution of complex practical problems. The paper describes in detail its use in design of the technique for identifying the required number of most preferable coal mine layouts. This technique ensures that in the early design stages one may develop feasible layouts for a wide range of geological conditions by means of a morphological analysis, provide an estimate of all the layouts in terms of 25 nonanalytical technological and economic indices (criteria), compare feasible layouts, and identify the most preferable among them.

1.2 MULTICRITERION DECISION-MAKING MODEL

When applying formal techniques to decision problems, alternatives should be compared and ordered by means of a decision-making model that permits estimates to be made and preferences to be revealed among them. Thus, construction and use of a model become part of the decision process (Ozernoi, 1974).

1.2.1 BASIC ELEMENTS OF THE MODEL

A multicriterion decision-making model may be presented in the following way:

$$\{t, S, K, X, f, G, r\},$$

- where
- t = a statement of the problem
 - S = a set of feasible alternatives
 - K = a set of criteria
 - X = the estimating scales
 - f = a mapping of the feasible alternatives for the set of vector-valued estimates
 - G = the decision maker's preference system
 - r = the decision rule

The statement of the problem characterizes the decision maker's goals. Depending on the meaningfulness of the statement, the most preferable alternative should be found, the set of feasible alternatives linearly ordered, or the set of non-inferior alternatives identified.

The set S is the totality of alternatives that satisfy constraints and suggest possible ways of achieving the desired goal. S may either be given initially or be formed during the analysis. Elements from the set S are also referred to as "feasible alternatives," "feasible solutions," "decision versions," "strategies," "actions," "variants," and so on.

Each alternative leads to a specific outcome, the consequences of which are estimated by the criteria $K_1, K_2, \dots, K_m, m \geq 2$. In some problems, a set of criteria K may be given, but it generally is formed during the course of the analysis. K would be criteria that are

- Considered to be important with regard to the desired goal of the decision maker
- Common for all feasible alternatives
- Necessary to characterize the overall decision utility, so that the decision maker wishes to obtain the most preferable estimates of those criteria (i.e., they cannot be presented in the form of constraints)

Among other terms used for designating the criteria are “local criteria,” “indices,” “performance indices,” “goal functions,” and “factors.”

A scale in the form of the set of estimates with order relations should be constructed for each criterion. The scales X_1, X_2, \dots, X_m forming the set X may be either numerical (discrete or continuous) or nonnumerical. The set X may contain various types of scales.

The Cartesian product $Y = X_1 \times X_2 \times \dots \times X_m$ forms the set of vector-valued estimates. Each alternative is estimated by the scales X_1, X_2, \dots, X_m , i.e., the set of feasible vector-valued estimates $A \subseteq Y$ corresponds to the set of feasible alternatives S by means of the mapping $f: S \rightarrow A$.

The totality G of some sets with preference relations (for instance, the criterion sets, intervals between estimates on the scales, feasible solutions of a certain type, and other data obtained during the analysis) comprises the decision maker's preference system. These preferences are usually revealed and formalized (and sometimes verbalized) during the part of the analysis in which the model is constructed.

A decision rule is an analytical expression, algorithm, or verbal expression that operates on the set of vector-valued estimates with preference relations to produce either an order or a quasi-order in the set A . The ordering of the set A by means of some decision rule and the mapping of f permit judgments to be transferred from preferences on set A to those on set S , and hence S can be ordered. The decision rule should permit an ordering of the set of feasible alternatives that corresponds to the meaningful statement of the problem and is in accordance with the assumptions and preference system of the decision maker. Various decision rules may be constructed, depending on the assumptions given and on the goals and preferences of the decision maker (Ozernoi, 1974).

The basic problems that arise in constructing models for multicriterion problems are caused by difficulties in obtaining the necessary information for developing such models. In many cases, a full list of feasible alternatives is not available; criteria characterizing the quality of alternatives are either incomplete or unknown; some or all criterion scales have not been constructed; estimates have not been obtained for all alternatives in terms of the criterion scales; the decision maker's

preference system is not known; and/or the decision rule has not been constructed for obtaining the required ordering.

Thus, the construction of a multicriterion decision model is a complex procedure involving both formalized and nonformalized steps. One should note that for any specific multicriterion problem, no "true" or "objective" model is available. The results of such a study should not be used unconditionally: because of a large number of factors that may be taken into account in any specific problem, it is always possible to present the same situation by different models. The appropriateness of these models may be checked only in the context of their practical application to real situations. Let us consider some elements of the multicriterion models and possible ways of constructing these models.

1.2.2 DETERMINING THE SET OF FEASIBLE ALTERNATIVES

No universal techniques are available for determining a set of feasible alternatives. Such alternatives are developed from information about similar phenomena in similar situations, from problem constraints, and from the experience of decision makers and experts.

A morphological analysis may be used in many problems to determine the set of feasible alternatives (Jantsch, 1967). This technique can be used to divide a problem into a number of independent subproblems (levels). For each level, possible solutions of subproblems (elements) are defined. A set of elements including exactly one element of each level is the decision alternative. The possibility of including each pair of elements from different levels in one decision alternative is investigated for feasibility. As a rule, the identification of the infeasible combinations decreases the number of elements in the set of alternatives. In addition, morphological analysis reveals new alternatives and facilitates meaningful description of the decision alternatives (Burchakov *et al.*, 1972; Emel'ianov *et al.*, 1972). One difficulty in conducting the morphological analysis, however, is that it is necessary to use experts' estimates to define the subproblems, form the elements of each level, and explore the possibilities of including elements of different levels within one alternative.

There are other techniques that can be used to determine the set of feasible alternatives. One is to use "brainstorming" (Jantsch, 1967). In constructing a "goal tree" (Lopukhin, 1971), various techniques can be used to achieve the lowest-level goals, and these techniques can lead to the formation of a set of feasible alternatives. Search in the parameter space (Artobolevskii *et al.*, 1974) and simulation are additional possibilities. A more detailed listing of feasible alternatives is an independently complex problem; a creative approach is often necessary in place of partially formalized techniques. And, moreover, the discovery of a new alternative often influences the decision process greatly.

1.2.3 ESTABLISHING THE SET OF CRITERIA AND CONSTRUCTING THE SCALES

Two tendencies should be taken into account in establishing a set of criteria. The first is the wish to construct a decision model that corresponds as closely as possible to a real-life problem. This tendency can lead to an increase in the number of criteria considered and thus complicate the model and restrict its use. The second tendency is to decrease the number of criteria to make the model simpler and less time-consuming to use. Let us say that the number of criteria is necessary and sufficient if introducing any additional criteria does not affect the problem solution but neglecting at least one of the chosen sets changes the results.

Forming a list of criteria is a complicated multistep iterative procedure that cannot be fully formalized because most information necessary for compiling the list can be obtained only through the assistance of the decision maker and experts in the relevant areas of expertise. Nonetheless, a certain sequence of reasonable steps for establishing the list of criteria is suggested (Ozernoi, 1974). A block diagram illustrating these steps is provided in Figure 1.1.

The first step of the procedure is to compile a preliminary list of criteria. This is generally done in consultation with the decision maker (and experts, as appropriate). An analysis of this list, step 2, reveals the most essential criteria for estimating the quality of the system from the point of view of the decision maker. The analysis focuses on the adequacy of the individual criteria; in particular, it is necessary to check if a particular criterion under consideration directly indicates the quality of the decision; if the criterion does not, it should not be included (for instance, "system redundancy" is not a criterion, although "reliability of the system" is).

Step 3 is the determination of at least one empirical indicator for each criterion (Beliaev, 1967). This permits the elimination of nonuniformity and inaccuracy in the criteria.

A scale is then constructed for each criterion in the form of a set of estimates with order relation (step 4). The choice of scale type depends on the measuring technique to be used and on the properties of the magnitude measured. Depending on the desired accuracy of measurement, values should be determined for the magnitude characterized by the empirical indicator, and these values should be in the region of feasible estimates.

In the course of constructing the scale, it might be found that a criterion is complex (Ozernoi, 1974), reflecting several alternative properties at once. In this case (step 5), empirical indicators of its components should be verbalized (transition to step 2). If a check shows that the criteria are not complex, updating of all criteria, empirical indicators, and scales developed thus far is necessary (step 6).

The mutual correspondence of each criterion and the corresponding scale is then checked (step 7). This check should indicate whether each estimate included in the scale characterizes a particular criterion or an additional one as well. The check should also indicate whether the criteria and their empirical indicators were verbalized correctly.

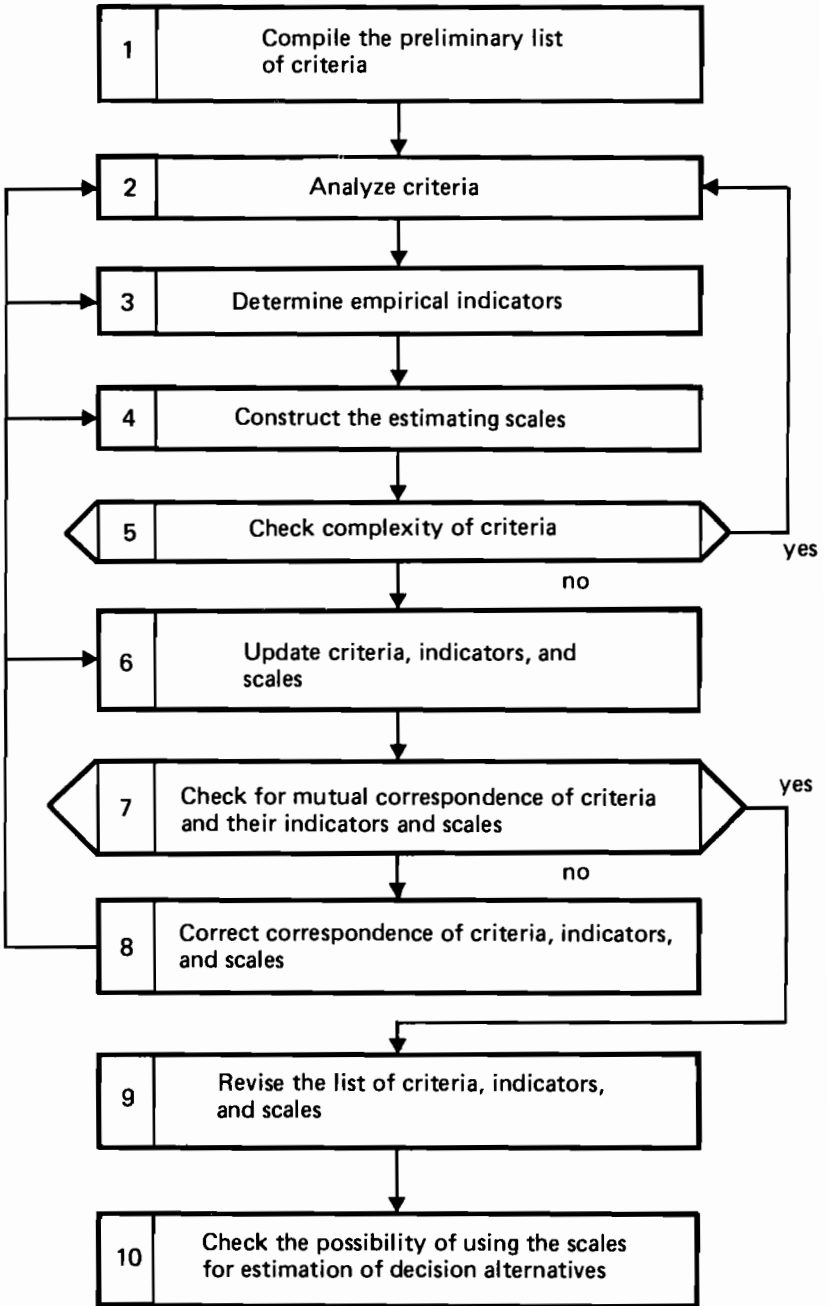

FIGURE 1.1 Sequence of 10 steps for establishing a set of criteria.

When there is no mutual correspondence in step 7, step 8 provides for analysis of the causes of noncorrespondence and a transition to one of the previous steps. If mutual correspondence of all the scales and criteria is established, revised lists are produced for the criteria, empirical indicators, and scales (step 9), and their appropriateness for estimation of the specific decision alternatives is checked (step 10).

1.2.4 USING THE SCALES TO DEFINE ESTIMATES OF THE DECISION ALTERNATIVES

Listing the criteria and constructing the scales permit definition of all the feasible decision alternatives in terms of the set of criteria. As a rule, alternatives may be estimated only by specialists – the experts or the decision maker. The “degree of objectivity” of the estimates is affected by the nature of the criterion, the type of scale, and participation of the expert in the process of obtaining the estimates. Thus, when quantitative criteria and criterion estimates are developed through calculations or direct measurements (provided these calculations or measurements have been carried out correctly), the estimates do not depend on the persons who developed them.

If, however, experts are asked to give estimates in terms of the criterion scales – involving judgment – different specialists may give different estimates for the same alternative. Therefore the analyst should try to construct scales so detailed and concrete that the answers of most experts will be practically identical (increasing the “degree of objectivity”).

When it is necessary to obtain estimates from a group of experts, the techniques and procedures used in sociology may be put to use to ensure that measurement is reliable and valid (Pinto and Grawitz, 1967).

If the numbers of feasible alternatives and criteria are too large (for instance, several thousand alternatives and several dozen criteria), it will be impossible for experts to achieve direct estimation of each decision alternative. In such a case, a procedure for forming feasible alternative estimates in terms of all criterion scales is suggested (Burchakov *et al.*, 1972; Emel’ianov *et al.*, 1972). This procedure is as follows:

- The set of feasible alternatives is presented in the form of a morphological diagram.
- Criteria are estimated in terms of which elements of a given level they contain.
- Estimates are obtained for all elements of each level in terms of the scales.
- Tables are constructed, in consultation with experts, containing estimates for all possible combinations of elements from each level in terms of the criterion under consideration.
- A computer is used to form the overall estimate for each alternative in terms of all the criteria.

1.2.5 ASSESSING THE DECISION MAKER'S PREFERENCE SYSTEM

Decision theory assumes that a decision maker uses some rational, uncontradictory preference system (or structure). Each decision maker has such a system, although he is not always aware of it. Assessing the decision maker's preference system is the most difficult step in formulating decision rules in multicriterion problems. A decision maker's preference judgments are linked closely with the relative importance of criteria, the estimates generated through the scales he uses, and so on. A serious difficulty in assessing these preference systems is that, in practice, answers to many questions are almost impossible to obtain. Moreover, attempts to gain some kinds of information about preferences may be completely futile. The more complicated the assumptions about these preferences, the lower the level of confidence in their substantiality. Thus, when assessing preferences, the analyst should use simple and reliable information and include only those data without which the problem could not be solved. The more complicated information about preferences should be used only if the available information does not give the ordering required in the problem.

Another difficulty in assessing the preference system is that a decision maker may in practice be inconsistent (Luce and Raiffa, 1957; Granberg, 1966). It is often difficult to discover inconsistency in the preference system, both for the decision maker and for the analyst who takes part in the decision process.

In assessing the decision maker's preference system, the analyst should

- Verbalize the assumptions on which preferences are based and verify their correctness
- Consider the methods of obtaining required information and choose the most convenient ones from the point of view of the decision maker

In multicriterion problems, assessing the preference system involves the decision maker's judgments on ordering the model's elements. For example, the assessment may consist of the following:

- Defining the relative importance of estimates included in each criterion scale by constructing order or numerical utility functions for each scale
- Specifying the intervals between estimates in the scale of each criterion
- Ordering vector-valued estimates that are combinations of the best and the worst estimates in the scales of all the criteria
- Examining the vector-valued estimates that differ when, for example, arbitrary estimates in the scales of two criteria are used.

1.2.6 CONSTRUCTING THE DECISION RULES

Constructing the decision rules is one of the most vital steps in solving a multicriterion problem. It is here that the notion of "preference" is concretely defined, and thus the order of the alternatives is determined.

Decision rules used in multicriterion problems may be divided into three groups: heuristic and axiomatic rules, according to the principles of their construction; one-step and multistep rules, according to procedure (Ozernoi, 1975); and rules leading to full or partial ordering of the set of feasible alternatives, according to purpose (Roy, 1972). The axiomatic approach to constructing decision rules assumes that a number of axioms are established for the set of alternatives, the nature (structure) of the decision maker's preference judgments, the possibility of obtaining preference information, and so on. This approach is the basis of prescriptive utility theory (von Neumann and Morgenstern, 1953; Fishburn, 1970), which considers various sets of axioms and thereby permits proof of the existence of a scalar, positively defined utility function on the set of vector-valued estimates. A decision rule in this sense is a generalized or global criterion and depends on alternative estimates in terms of all the criteria.

The most thoroughly studied forms of utility function are the additive, multiplicative, and quasi-additive forms.¹ The basic difficulty in constructing the utility function is that the axioms cannot be accepted for all practical problems, and the appropriateness of these axioms is often difficult to verify. For example, the axioms of completeness or negative transitivity (Fishburn, 1970) of the preference system cannot be satisfied in many situations. There are a number of works that treat the existence of utility functions for noncomplete preference relations² but questions of practical utility function construction are given little consideration. Thus, decision rules implementing the construction of the utility function generally include a full ordering of alternatives. Using such decision rules in problems where a full ordering is not required (for instance, in identifying the required number of most preferable alternatives) results in redundant information in the decision maker's preference system.

Several approaches are used to construct decision rules. The axiomatic approach does not always require construction of the utility function.³ The heuristic approach means a decision rule based on quite reasonable considerations, although no assumptions are formulated.⁴ Decision rules based on this approach often base decisions on a subset of the criteria (Germeier, 1971a,b). A number of works (e.g., Borisov, 1972) consider a set of decision rules from which a decision maker should select one consistent with his understanding of the problem. Such an approach is justly criticized by Venttsel (1972) for transferring the arbitrariness from one area into another.

The construction procedures for both heuristic and axiomatic decision rules may be one-step or multistep. Multistep decision-making techniques make it

¹ See, for example, Roy (1972), Fishburn (1966, 1967a, 1974), Yntema and Klem (1965), and Keeney (1968, 1974).

² See examples of this in Fishburn (1970), Luce (1956), Aumann (1962), Chipman *et al.* (1969), and White (1972).

³ See Roy (1972), Larichev (1972), Shapot (1971), and Buianov and Ozernoi (1974 and 1975).

⁴ See Roy (1968 and 1972), Larichev (1971), Podinovskii and Gavrilov (1975), Ozernoi (1971), Volkovich (1968), Salukvadze (1971), and Dedikov and Kukharev (1971).

possible to combine mathematical models with the experience and intuition of the decision maker.¹ With such procedures, a decision maker answers questions revealing preferences. This approach implements the decision rule of a certain type and subsequently updates some of its parameters, although it does not guarantee consistency of the preference information obtained.

Analysis of the techniques available for constructing decision rules shows that in general one-step procedures are used in problems where a full ordering of alternatives is required; multistep procedures are preferred in problems that call for a partial ordering.

None of the known decision rules may be considered free of limitations (Ozernoi, 1975; Roy, 1972; Larichev, 1971). Thus, the construction of universally applicable decision rules is likely to be impossible in principle because different decision rules may be constructed for different orderings of the set of feasible alternatives, depending on the decision maker's goals, his preferences, and the possibilities of obtaining data. Accordingly, for each specific problem general procedures should be developed for constructing decision rules, depending on the desired result. One suggested procedure is described in the next section.

1.3 A PROCEDURE FOR CONSTRUCTING THE DECISION RULES

1.3.1 BASIC CONCEPTS

Difficulties in assessing the decision maker's preferences seem to call for an iterative procedure for constructing decision rules. Two basic requirements must be met:

- The additional information on preferences obtained from a decision maker at the $(i + 1)$ step of the decision procedure should permit preferences to be established between at least two vector-valued estimates that are incomparable at the i th step (the criterion of meaningfulness applied to additional information).
- The preference between any two vector-valued estimates revealed at the i th step of the decision procedure should not change in subsequent steps (the criterion of consistency applied to additional information).

The use of a decision rule in comparing the vector-valued estimates unambiguously sets a certain binary relation on the vector-valued estimates of the set Y . Depending on the properties of the binary relation thus obtained, it is referred to either as the preference–indifference relation $\{R, Y\}$ (nonstrict preference) when it is transitive and reflexive, or as the strict preference relation $\{P, Y\}$ when it is transitive and nonreflexive (Fishburn, 1964).

¹These techniques are demonstrated in Shapot (1971), Buianov and Ozernoi (1975), Podinovskii and Gavrilov (1975), and Roy (1968).

Let us denote the binary preference–indifference relationship obtained when we compare the vector-valued estimates from the set Y through the i th decision rule of the procedure as $\{R^i, Y\}$. This relationship is a quasi-order one (i.e., transitive and reflexive); it determines the relationships of strict preference, equivalence, and noncomparability (Gaft and Ozernoi, 1973). Thus,

DEFINITION 1 Define the relationships of strict preference, equivalence, and noncomparability in the following way:

$$\{P^i, Y\}, \text{ where } P^i = \{(x, y) \in Y \times Y \mid (x, y) \in R^i, (y, x) \notin R^i\}$$

$$\{I^i, Y\}, \text{ where } I^i = \{(x, y) \in Y \times Y \mid (x, y) \in R^i, (y, x) \in R^i\}$$

$$\{N^i, Y\}, \text{ where } N^i = \{(x, y) \in Y \times Y \mid (x, y) \notin R^i, (y, x) \notin R^i\}$$

Let us consider the properties of binary relationships that may be obtained at various steps in constructing the decision rules leading to the certain ordering required in the problem.

The above requirements of iterative procedure for constructing decision rules can be formally expressed as

$$R^i \subset R^{i+1} \quad (1.1)$$

$$P^i \subseteq P^{i+1} \quad (1.2)$$

Equation (1.1) dictates the strictness of the insertion; Eq. (1.2), nonstrictness of the insertion, is explained by the fact that the information obtained at the $(i + 1)$ step reveals the strict preference among the vector-valued estimates that were incomparable at the i th step, as well as their equivalence.

Assumptions written as Eqs. (1.1) and (1.2) should be used with care by the analyst, since in practical cases decision makers may change their preferences in the course of analyzing and solving the problem, which will lead to inconsistency of information obtained from those preferences. Thus, the information gained in constructing the decision rule should be thoroughly analyzed and compared with that obtained earlier. As a result of this analysis, any contradictions (and their sources) will be discovered, and measures can be taken to eliminate them. Only after this checking can the information obtained be used for constructing a decision rule.

Let us consider some implications of the assumptions of Eqs. (1.1) and (1.2).

RESULT 1 If the relations $\{P^i, Y\}$ and $\{R^{i+1}, Y\}$ satisfy Eq. (1.1), the following expressions result:

$$I^i \subseteq I^{i+1} \quad (1.3)$$

$$N^i \supset N^{i+1} \quad (1.4)$$

$$P^i \cup N^i \supseteq P^{i+1} \quad (1.5)$$

$$I^i \cup N^i \supseteq I^{i+1} \quad (1.6)$$

At least one of Eqs. (1.5) and (1.6) will be strict.

Equations (1.3) through (1.6) may be used to check the consistency of the information obtained from a decision maker.

Relations satisfying Eqs. (1.1) and (1.2) will be referred to as inserted. Let us consider the relationships among the sets of noninferior elements that are isolated by using inserted relations. Suppose that a set of scales is given for the criteria with which the alternatives are estimated and thus the set of vector-valued estimates Y is defined. The set of feasible solutions S corresponds to some vector-valued estimates in subset $A \subseteq Y$. Thus,

DEFINITION 2 Let the subset $L_{R^i}(A)$ be defined as the set of $x \in A$ such that no $y \in A$ exists with y preferred to x using P^i . We define $L_{R^i}(A)$ as the set of noninferior estimates derived from A using the preference–indifference relationship $\{R^i, Y\}$.

RESULT 2 If the R^i, R^{i+1} satisfy Eq. (1.1), the following is true:

$$L_{R^i}(A) \supseteq L_{R^{i+1}}(A) \quad (1.7)$$

Equation (1.7) indicates that the $(i + 1)$ step diminishes (or at least does not increase) the subset of noninferior estimates obtained at the i th step.

It is not difficult to check the subset $L_{R^i}(A)$ to ensure that it consists of incomparable and equivalent elements. Therefore, the necessary and sufficient condition for

$$L_{R^i}(A) \supset L_{R^{i+1}}(A)$$

will reveal preferences among the incomparable elements from $L_{R^i}(A)$ at the $(i + 1)$ step.

1.3.2 CLASSIFICATION OF PREFERENCE INFORMATION

In constructing decision rules the question arises: What sort of information about the decision maker's preferences is necessary, and how much information is necessary to solve the multicriterion problem? Various ways of obtaining preference information are described in the literature.¹

Let us consider the classification of information used in various models of multicriterion problems for constructing the decision rules. Such classification was initially suggested by Roy (1969); however, the scheme lacked a uniform classifying "yardstick." In this paper we select as the yardstick the relationship between the information obtained and one or several criteria. Three classes (types) of information can thus be identified (Ozernoi and Gaft, 1974):

¹ Yntema and Klem (1965), Larichev (1972), Fishburn (1964, 1967b), and Goorin (1974).

- Information about the influence of a change in estimates for one criterion scale on the overall value, or utility, of the alternative (type *A* information)
- Information about the way a change in estimates for one criterion scale – in comparison with changes over another criterion scale – influences the overall value, or utility, of the alternative (type *B* information)
- Information about the way a change in estimates for the scales of one group of criteria – in comparison with those for another group, and provided that at least one of the compared groups includes more than one scale – influences the overall value of the alternative (type *C* information)

Let us consider these types of information. Assume that a scale (at least, the ordering one) is constructed for each criterion. Obtaining information of the first type may be regarded as the process of measuring the utilities of the estimates. In the course of measuring, the elements in the scales for other criteria should be maintained at a certain fixed level (Stevens, 1951). Thus, it is convenient to classify type *A* information by the utility scale that may be obtained from it. Obtaining type *B* and type *C* information makes comparison of various utility scales possible and reduces the incomparability of the alternatives. Information of this type should be classified by the degree to which it influences the elimination of the incomparability of the vector-valued estimates.

Type *A* information includes the following kinds of information:

A_1 : Information about various preferred estimates for a one-criterion scale. This information, if obtained for each estimate, allows the analyst to construct an ordinal utility scale for the criterion, and it is generally possible to accomplish the same for each criterion in the decision problem.

A_2 : Information about changes in estimates in the criterion scale that make it preferable to other scales. This information, if obtained for changes in all estimates, allows the analyst to construct an interval utility scale for the criterion.

A_3 : Information about the relationships between the utility changes and changes in estimates for the criterion scale, or information about the absolute values of the utilities of the estimates. Such information, if obtained for all relationships in numerical form, permits the analyst to construct a utility relationship scale for the criterion.

Type *B* information is classified in the following way:

B_0 : Complete lack of type *B* information.

B_1 : Information about a change in estimates, from best to worst, for the scale of a criterion, such that this change is preferable to a similar change in estimates for the scale of another criterion.

B_2 : Information about a change in estimates for the scale of one criterion, from

best to some other estimate, such that this change is preferable to a similar change in estimates for the scale of another criterion.

B_3 : Information about an arbitrary change in estimates for the scale of one criterion, such that this change is preferable to an arbitrary change in estimates for the scale of another criterion.

B_4 : Information about changes in utility relationships corresponding to changes in estimates for the scales of two different criteria.

Type C information is classified as follows:

C_0 : Complete lack of type C information.

C_1 : Information about changes in arbitrary estimates for the scales of one group of criteria, such that such changes are preferable to changes in arbitrary estimates for the scales of another group of criteria. This information allows the analyst to develop further details regarding both the nature of the changes in estimates (similar to that in B_1 , B_2 , B_3 , and B_4) and the number of criteria in the respective groups.

1.3.3 THE SEQUENCE OF STEPS FOR OBTAINING INFORMATION

The classification scheme outlined above contains all the components in the sequence for obtaining the necessary information to construct the ordering required in the problem. A diagram of the procedure for obtaining such information is shown in Figure 1.2. It should be mentioned that the information necessary for the ordering may not always be obtained from a decision maker. This means that the sequence of steps for obtaining the information shown in Figure 1.2 cannot be correlated to each specific problem. A sequence may end at any step either because the required ordering is completed or because further information is impossible to obtain. Nevertheless, in all cases the sequence of obtaining the various types of information corresponds to that shown in Figure 1.2. If there is no need for a certain type of information, that does not imply that more complicated information is not necessary.

There are no $A_2B_0C_0(C_1)$, $A_3B_0C_0(C_1)$, $A_2B_1C_0(C_1)$, $A_3B_1C_0(C_1)$, or $A_1B_4C_0(C_1)$ classes of information in Figure 1.2 because such information does not reveal new preferences among the incomparable alternatives outlined in previous steps. For example, if a problem contains the $A_1B_1C_0(C_1)$ class of information, type A_2 information is useless.

1.4 EXAMPLES OF DECISION-RULE CONSTRUCTION

Let us consider the way decision rules are formed using the classification of preference information suggested in section 1.3.2. Here we shall assume the inde-

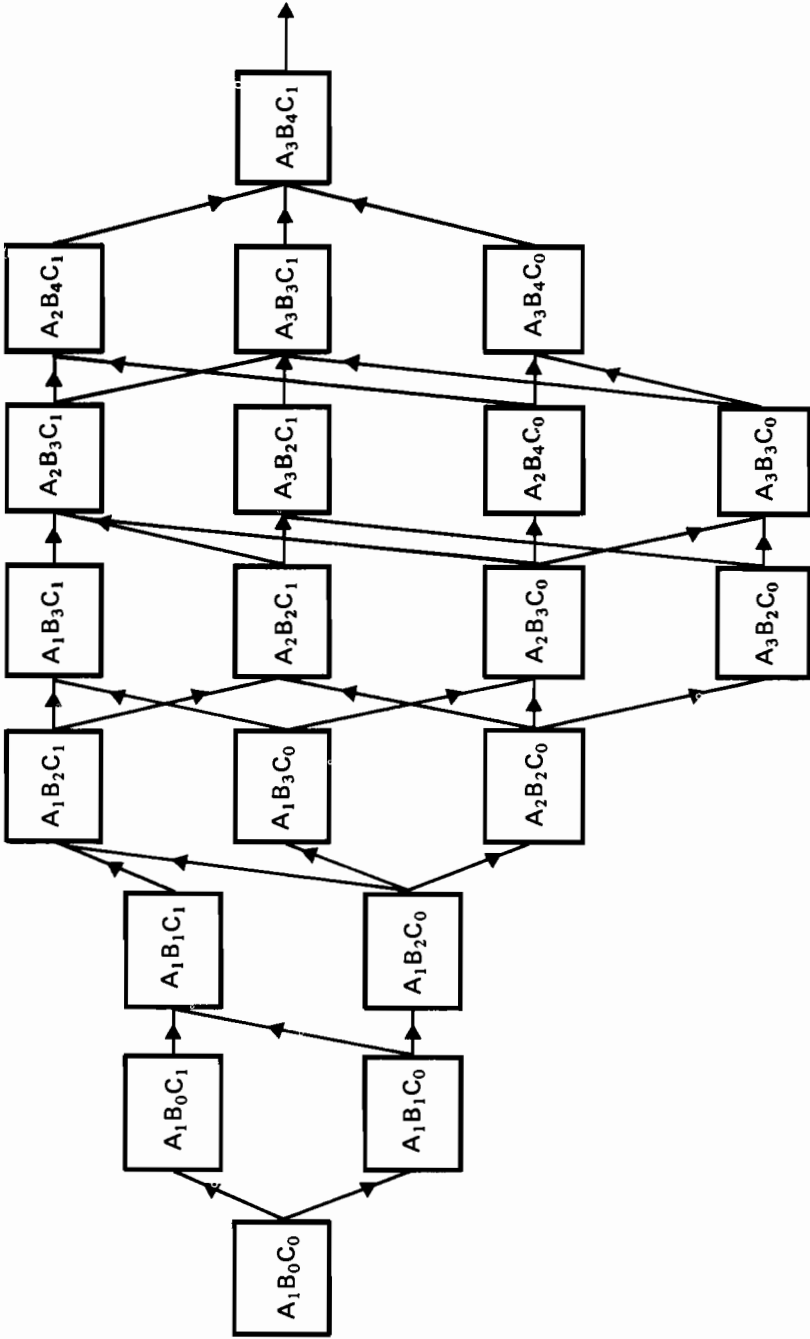

FIGURE 1.2 Sequence for obtaining information.

pendence of criteria on preference (Keeney, 1974) – i.e., assume that information on preferences with regard to several criteria does not depend on fixed estimates in the other criterion scales.

According to the classification of preference information, $A_1B_0C_0$ is the simplest type of information. This information permits construction of the decision rule that establishes the following relationship of preference–indifference $\{R^0, Y\}$ for the set of vector-valued estimates Y : a vector-valued estimate $x \in Y$ is not less preferable than $y \in Y$ if each component of x is not less preferable than the corresponding component of y .

There are such cases when the use of the decision rule leading to the relation R^0 results in identification of only one noninferior (maximal) vector-valued estimate from the set A or in linear ordering of this set. In the majority of cases, however, more complicated information than $A_1B_0C_0$ is necessary to solve the problem. Given A_1 , the use of A_2 or A_3 information does not produce any stronger decision rule unless some type B information is obtained.

1.4.1 DECISION RULES BASED ON $A_1B_2C_0$ INFORMATION

Let us construct a decision rule using the $A_1B_2C_0$ information. Assume that the A_1 information is available for every scale and that B_2 information can be obtained for certain scale pairs derived from X .

Consider the partitioning of the set X into J classes $\{M_1, M_2, \dots, M_J\}$, $1 \leq j \leq J$. According to the assumptions made on the possibility of obtaining B_2 information for each pair of scales belonging to one class, the analyst may order the influence of specific levels of these pairs on the alternative utility. By utilizing the independence assumption, this information can be used to construct uniform utility scales for each class M_j . After uniform utility scales are constructed for all scales of each class, a decision rule based on $A_1B_2C_0$ information is used over the reduced number of dimensions in the same manner as the decision rule based on $A_1B_0C_0$.

A decision rule based on $A_1B_2C_0$ information should unite the decision rules corresponding to different partitionings of the set X . Let us say that such a decision rule leads to the preference–indifference relationship $\{R^*, Y\}$.

1.4.2 DECISION RULES BASED ON $A_3B_4C_0$ INFORMATION

The vector-valued estimates $y, z \in Y$ may not be comparable to relationship R^* for two reasons: (a) there is a class of criteria scales for which the estimates cannot give preference to the vectors y and z ; and (b) there are two classes of criteria such that the estimates corresponding to one of them give preference to vector y and the estimates corresponding to the other, to vector z .

It is possible to bring about partial elimination of incomparability in R^* attributable to the first reason if a change is made from reliance on type A_1 information, which permits construction of an order utility scale, to type A_2 , which leads to

construction of an interval utility scale. Another way to accomplish this partial elimination of incomparability is to change from B_2 to B_3 information. To eliminate incomparability in R^* completely, $A_3B_4C_0$ information is necessary. A_3 information, which permits construction of utility relationships for the criterion, should be obtained for all scales of this class, thereby producing estimates that would lead to elimination of incomparability. B_4 information should be obtained for all pairs of scales in this class.

1.5 A SOLUTION TECHNIQUE FOR MULTICRITERION PROBLEMS

A diagram is provided in Figure 1.3 for developing and using the multicriterion model in a decision problem. A statement of the problem (step 1) is followed by establishment of the set of feasible alternatives (step 2), a list of criteria and empirical indicators (step 3), and construction of scales (step 4). All alternative estimates are defined in terms of the scale for each criterion (step 5).

A decision rule stating the desired result is constructed according to the procedure suggested in section 1.3. This procedure is generally carried out in several steps. First, information is obtained about a decision maker's preference system (step 6). This information is analyzed, verified, and then used to construct a decision rule (step 7). The sequence for obtaining this information is the same as that illustrated in Figure 1.2.

The decision rules obtained at each step of the procedure are used for ordering the set of feasible alternatives (step 8). The results of this ordering are analyzed (step 9), and a check is made to ascertain that the ordering is satisfactory (step 10); unsatisfactory ordering could be caused by contradictory preference information obtained at various steps, an incomplete set of criteria characterizing the quality of the feasible alternatives, disparity between the estimating scales for certain criteria and measuring potential, or errors in estimating alternatives in scales of certain criteria.

Depending on the reasons for the unsatisfactory ordering, different measures may be taken to eliminate them. It may be necessary to update the problem statement; include new alternatives in the initial set; or update the list of criteria, their scales, and estimates of alternatives in terms of new scales. It may also be necessary to correct the information upon which preferences or decision rules are based.

A check should be made to determine if the ordering of the set of feasible alternatives obtained satisfies the problem stated (step 11); if there is no correspondence, some additional preference information should be obtained and a new decision rule constructed. The analysis of incomparable alternatives in the ordering in step 11 makes it possible to establish the class of information necessary to form a new decision rule.

When the ordering of alternatives meets the problem requirements and is accepted by the decision maker as satisfactory, it is regarded as final. If a decision

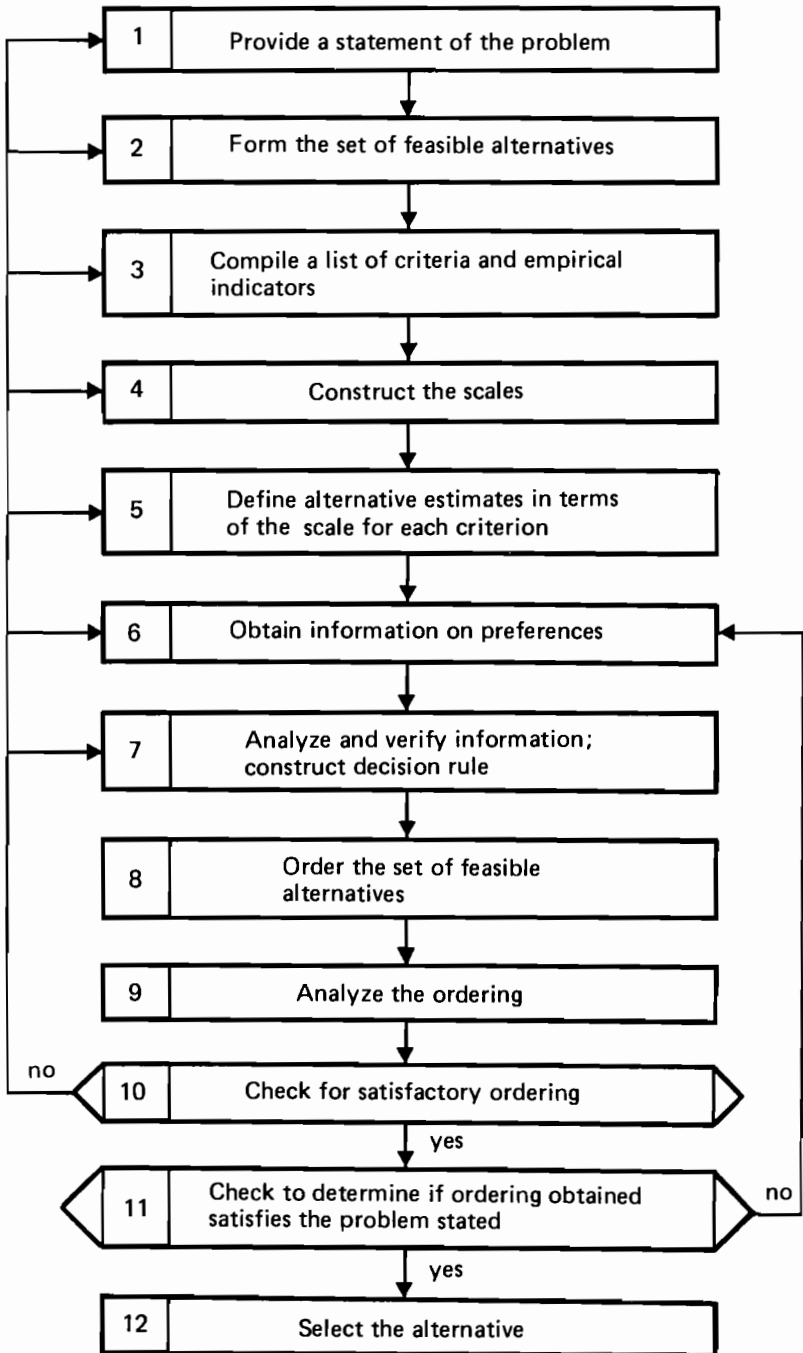

FIGURE 1.3 Sequence of 12 steps for developing and using a multicriteria model.

maker behaves rationally, he will make a decision consistent with the ordering obtained (step 12).

1.6 APPLICATION: THE PROBLEM OF SELECTING COAL MINE LAYOUTS

1.6.1 A STATEMENT OF THE PROBLEM

The basic problem in the design and reconstruction of working coal mines is the application of a technological–economic (technoeconomic) index to the optimal layout. There may be a great number of feasible layout alternatives for any geological condition (for some types of deposits the number exceeds 7,000), yet no reliable techniques for evaluation are available. Accurate computations of the technoeconomic indices are difficult to program, particularly when there are many possible layouts to process. Today this selection is performed in two stages. At the first stage, a team of expert designers identifies several layouts that are optimal in the view of the group. The number identified at this stage is dictated by further possibilities observed for mine development. At the second stage, technoeconomic calculations are performed for the layouts; this may require many months of work for a large number of design engineers. These calculations are necessary for the identification of the one optimal layout.

In the first stage the number of layouts is usually very high; no single expert could possibly analyze all of them. The technoeconomic indexes of the layout are unknown at this point and cannot be used in selection of the “best” layout; thus, each expert has to rely on his own selection rule. The rule intuitively used by the expert can be based either on recognition of a large number of criteria characterizing the layout or on the desire to identify the layouts that contain “the best” elements in the opinion of the expert. In the first case, there is the danger that layouts with high technoeconomic indexes may be left out at the initial stages and eliminated from further consideration because the experts have different sets of criteria and hold different views on the comparative importance of each criterion. In the latter case, it is generally impossible to find one layout that contains only those “best” features, and so the experts have to reduce the requirements for the elements. The question of which requirements are the most essential is resolved by each expert independently, depending on his knowledge and experience.

Thus, the experts’ opinions on the advantages and disadvantages of certain layouts may differ greatly. Expert opinion is one approach to the selection of an optimal layout, and in the absence of impartial data, it might be the only approach. Sound decisions require, however, a well-defined statement of the problem, special expert estimation and processing procedures, and the use of decision-making techniques. The search for an optimal coal mine layout is clearly a multicriterion decision problem. Let us consider a technique suggested for solving the problem.

1.6.2 DETERMINING THE SET OF FEASIBLE COAL MINE LAYOUTS

In a coal mine layout six possible levels or considerations can be distinguished: methods for opening, opening layout, sequence of preparatory operations, preparatory technology, sequence of steps in working the mine, and the system of mining. Depending on the type of mining to be undertaken and the geological conditions, each level contains a finite number of elements from which a single element is selected for each alternative layout. Not all elements taken in pairs from different levels, however, may be joined in one layout scheme for economical or technological reasons. In some cases the number of feasible layout alternatives exceeds 7×10^3 (and the number of possible layouts exceeds 2×10^5).

The analysis of feasible layout alternatives can be carried out on the basis of a morphological analysis (Jantsch, 1967; Burchakov *et al.*, 1972; Emel'ianov *et al.*, 1972). All feasible layout alternatives may be presented in the form of a morphological scheme. Each horizontal row of vertices will correspond to a level of a mine layout design, and the vertices themselves to elements of a given level. Links among the vertices of different levels allow for the possibility of combining the corresponding elements into a joint technological scheme. The morphological scheme presents each feasible alternative in the form of a chain of elements (one element from each level).

1.6.3 ESTABLISHING THE CRITERIA AND CONSTRUCTING THE SCALES

The set of criteria characterizing the quality of a mine layout in the early design stages is the union of the sets of criteria characterizing each level of the layout. For each level, sets of criteria can be established and corresponding scales can be constructed. A complete list of criteria, scales, and estimates for selecting layouts is given in Burchakov *et al.* (1972). The list contains 25 technical, economic, and technoeconomic criteria; all criteria are qualitative measures, and all scales are ordering ones. An example of a criterion is "possibility of mine modernization without affecting its work." The corresponding scale is "(a) possible, (b) partially possible, (c) impossible."

1.6.4 DEVELOPING ESTIMATES

The number of possible combinations of elements to be estimated may be very large (of the order of several thousand). This number may be reduced by using an assumption: any two elements of one level having the same estimates in terms of the scale of one criterion may be said to represent the estimate of the entire alternative in terms of the scale of this criterion. Thus, rather than estimate all possible combinations of elements from levels affecting the overall layout estimate, it is sufficient to estimate all possible combinations of elements of these levels in terms of one criterion.

For each type of mining and each geological condition, it is possible to develop

tables to estimate various combinations of elements from two or more levels based on the scales of the criteria met at each level. The tables developed by Burchakov *et al.* (1972) for coal deposits might serve as examples.

1.6.5 FORMING THE SEQUENCE OF DECISION RULES

The set of preferred coal mine layouts containing approximately the desired number of alternatives can be identified by using three decision rules based on successive implementation of information of the types $A_1B_0C_0$, $A_1B_2C_0$, and $A_3B_4C_0$. When constructing a decision rule based on $A_3B_4C_0$ information, all scales divide into four classes; A_3 information can be obtained for all scales of each class, and B_4 information for all pairs of scales of each class. Changes in utility relationships can be estimated by numerical intervals (Burchakov *et al.*, 1972).

The technique outlined above, based on the construction of successive decision rules, was used to identify 21 preferable mine layouts for the Chicherbay area of Kuzbass and 4 layouts for the reconstruction of a V.I. Lenin "Tom'-Usinskaya 1-2" mine, one of the largest in the Soviet Union. In the former case, there was an initial set of feasible layouts containing 7,704 possibilities; in the latter case, 3,126. It is evident that the suggested technique facilitated selection, considerably shortened the time, and reduced the cost of design. The technique is currently being used in the design of other coal mines in the Soviet Union.

REFERENCES

- Artobolevskii, I.I., *et al.* 1974. Looking for compromise alternatives in selecting machine parameters. (In Russian.) *Doklady Akademii Nauk SSSR*, Vol. 219, No. 1, pp. 53-56.
- Aumann, R.J. 1962. Utility theory without the completeness axiom. *Econometrica*, Vol. 13, No. 3, pp. 445-462.
- Beliaev, E.V. 1967. Problems of sociological measurement. (In Russian.) *Voprosy Filosofii*, No. 7, pp. 22-33.
- Borisov, V.I. 1972. Vector optimization problems. In *Operations Research: Methodological Aspects*. (In Russian.) Nauka, Moscow.
- Buianov, B.B., and V.M. Ozernoi. 1974. On one method of decision making under a vector criterion. (In Russian.) *Izvestiya Akademii Nauk SSSR, Tekhnicheskaya Kibernetika*, No. 3, pp. 80-84.
- Buianov, B.B., and V.M. Ozernoi. 1975. Sufficient preference conditions in multiattribute decision problems. In *Problems of Cybernetics, Decision Making Theory*. (In Russian.) Soviet Radio Publishing House, Moscow.
- Burchakov, A.S., *et al.* 1972. A procedure for selecting a set of preferable (rational) alternatives of coal mine process flows. (In Russian.) Lecture notes for a course entitled "Basics of Coal Mine Design." Moscow Mining Institute.
- Chipman, J.S., *et al.* 1969. *Studies in Mathematical Foundations of Utility and Demand Theory*. World Publishing Company, New York.
- Dedikov, E.A., and B.E. Kukharev. 1971. An approach to solving multicriteria problems. (In Russian.) *Pribory i Sistemy Avtomatiki*, Vol. 19.

- Emel'ianov, S.V., et al. 1972. Selection of rational versions of mine process flows with respect to multiple criteria. (In Russian.) *Izvestiya Vysshikh Uchebnykh Zavedenii, Gornyi Zhurnal*, No. 5, pp. 8–14.
- Fishburn, P.C. 1964. *Decision and Value Theory*. John Wiley, New York.
- Fishburn, P.C. 1966. A note on recent developments in additive utility theories for multiple-factor situations. *Operations Research*, Vol. 14, pp. 1143–1148.
- Fishburn, P.C. 1967a. Methods of estimating additive utilities. *Management Science*, Vol. 13, No. 7, pp. 435–451.
- Fishburn, P.C. 1967b. Additive utilities with finite sets: Applications in the management sciences. *Naval Research Logistics Quarterly*, Vol. 14, No. 1, pp. 1–13.
- Fishburn, P.C. 1970. *Utility Theory for Decision Making*. John Wiley, New York.
- Fishburn, P.C. 1974. Von Neumann–Morgenstern utility functions on two attributes. *Operations Research*, Vol. 22, No. 1, pp. 35–45.
- Gaft, M.G., and V.M. Ozernoi. 1973. Isolation of a set of noninferior solutions and their estimates in decision-making problems. (In Russian.) *Avtomatika i Telemekhanika*, Vol. 33, No. 11, pp. 85–94.
- Germeier, Iu.B. 1971a. On vector-valued criteria of effectiveness convolutions into a single criterion under uncertainty in convolution parameters. In *Cybernetics Serves Communism* (A.I. Berg, ed.). (In Russian.) Vol. 6. Energiia Publishing House, Moscow.
- Germeier, Iu.B. 1971b. *Introduction to the Theory of Operations Research*. (In Russian.) Nauka, Moscow.
- Goorin, L.S. 1974. Some aspects of vector optimization. (In Russian.) *Avtomatika i Vichislitel'naja Tekhnika*, No. 4, pp. 40–44.
- Granberg, A.G. 1966. Transitivity of individual and collective preferences in constructing goal functions. In *Quantitative Methods in Sociology*. (In Russian.) Nauka, Moscow.
- Jantsch, E. 1967. *Technological Forecasting in Perspective*. Organization for Economic Co-operation and Development, Paris.
- Keeney, R.L. 1968. Evaluating multidimensional situations using a quasi-separable utility function. *IEEE Transactions on Man–Machine Systems*, Vol. MMS-9, No. 2, pp. 25–28.
- Keeney, R.L. 1974. Multiplicative utility functions. *Operations Research*, Vol. 22, No. 1, pp. 22–34.
- Larichev, O.I. 1971. Man–computer decision-making procedures: A survey. (In Russian.) *Avtomatika i Telemekhanika*, Vol. 32, No. 12, pp. 130–142.
- Larichev, O.I. 1972. Method for evaluating R&D projects. (In Russian.) *Avtomatika i Telemekhanika*, Vol. 33, Part 1, pp. 1356–1360.
- Lopukhin, M.M. 1971. *PATTERN – A Technique for R & D Planning and Forecasting*. (In Russian.) Soviet Radio Publishing House, Moscow.
- Luce, R.D. 1956. Semi-orders and a theory of utility discrimination. *Econometrica*, Vol. 24, No. 1, pp. 178–191.
- Luce, R.D., and H. Raiffa. 1957. *Games and Decisions*. John Wiley, New York.
- Ozernoi, V.M. 1971. Decision making: A survey. (In Russian.) *Avtomatika i Telemekhanika*, Vol. 32, No. 11, pp. 106–121.
- Ozernoi, V.M. 1974. Principles of construction and the use of multiattribute decision-making models. In *Decision-Making Problems*. (In Russian.) Proceedings of the Institute of Control Sciences, Vol. 5, Moscow.
- Ozernoi, V.M. 1975. Problems and techniques of decision making under a vector criterion. In *Problems of Cybernetics, Decision-Making*. (In Russian.) Soviet Radio Publishing House, Moscow.
- Ozernoi, V.M., and M.G. Gaft. 1974. Construction of decision rules in multiattribute decision-making problems. *Decision-Making Problems*. (In Russian.) Proceedings of the Institute of Control Sciences, Vol. 5, Moscow.

- Pinto, R., and M. Grawitz. 1967. *Methods of Social Sciences*. (In French.) 2nd ed. Dalloz, Paris.
- Podinovskii, V.V., and V.M. Gavrilov. 1975. *Optimization over Sequentially Applied Criteria*. (In Russian.) Soviet Radio Publishing House, Moscow.
- Roy, B. 1969. A propos de l'agrégation d'ordres complets: Considérations théoriques et pratiques. In *La décision – agrégation et dynamique des ordres de préférence*. Centre National de la Recherche Scientifique, Aix-en-Provence.
- Roy, B. 1968. Classement et choix en présence de points de vue multiples. *Revue Française d'Informatique et de Recherche Operationnelle*, No. 8, pp. 57–75.
- Roy, B. 1972. Décisions avec critères multiples: problèmes et méthodes. *Revue METRA*, Vol. 11, No. 1, pp. 121–151.
- Salukvadze, M.E. 1971. Optimization of vector functions: II. The analytic construction of optimal controls. (In Russian.) *Avtomatika i Telemekhanika*, Vol. 32, No. 9, pp. 5–15.
- Shapot, D.V. 1971. On construction of performance criteria for technical plants. (In Russian.) *Izvestiya Akademii Nauk SSSR, Tekhnicheskaya Kibernetika*, No. 6, pp. 53–59.
- Stevens, S.S. 1951. Mathematics, measurement, and psychophysics. In *Handbook of Experimental Psychology* (S.S. Stevens, ed.). John Wiley, New York.
- Venttsel, E.S. 1972. Discussion during the Symposium on Operations Research and Analysis of Scientific Progress. In *Operations Research, Methodological Aspects*. (In Russian.) Nauka, Moscow, pp. 106–111.
- Volkovich, V.L. 1968. Methods for decision making with respect to a set of optimality criteria: A Survey. In *Proceedings of the Seminar on Complex Control Systems*. Vol. 1. (In Russian.) Naukova Dumka Publications, Kiev.
- von Neumann, J., and O. Morgenstern. 1953. *Theory of Games and Economic Behavior*. Princeton University Press, Princeton, New Jersey.
- White, D.H. 1972. Uncertain value functions. *Management Science*, Vol. 19, No. 1, pp. 31–41.
- Yntema, D.B., and L. Klem. 1965. Telling a computer how to evaluate a multidimensional situation. *IEEE Transactions on Human Factors in Electronics*, Vol. HFE-6, No. 1, pp. 3–13.

2 Partial Preference Analysis and Decision-Aid: The Fuzzy Outranking Relation Concept

B. Roy

The purpose of this paper is to examine some major aspects of a prescriptive theory, called *Decision-Aid*.

Whenever a decision-making problem comes on stage, it is understood that there is a decision maker, for whom the scientist is working, waiting in the wings. The objective of Decision-Aid is to shed light on the decision but not to fix it; in particular, Decision-Aid must not suppress the activity and free will of the decision maker. Moreover, it is convenient to introduce a third person, almost always present, who stands between the scientist and the decision maker (whom the scientist never, so to speak, meets); we will call this third person the “demander.” Generally, it is the demander who sets the problem, and it is he who is confused at times, but wrongly, with the decision maker, for it is he who commissions and finally judges the scientist’s work and conclusions.

It is well to bear in mind that a decision is very rarely the reflection of the preferences of an isolated person, nor even of a well-defined group of people. For example, the person who accepts or rejects a demand for credit is often influenced by the impression his subordinates may have of the client who asks for credit – nevertheless, this person will try to conform to the company’s policy for this type of service. *The decision is an important stage in the evolution of a process, and providing Decision-Aid means taking part in this process.* This implies the identification of the one among the various actors who plays a determining role in the achievement of the process and for whom, or in whose name, Decision-Aid is provided. In our eyes it is this more or less circled entity that covers the concept of “decision maker.”

It must be stressed that above all it is the demander’s duty to furnish the scientist with the means of acquiring as good an understanding as possible (within his available means) of the class of phenomena and question field specific to the

The author wishes to thank Howard Raiffa and Jeannette Lindsay for the amendments they have made to this paper.

decision problem. In particular, it is up to him not to imprison the scientist in an ill-defined problem – i.e. *an out-of-context problem or one formulated in such a way that it cannot be incorporated into the decision process*. The model, no matter how lifelike it is, is never reality but a substitute; the model is designed to be appropriate only to a specific field of questions, about which it is destined to give an insight, or rather an idea, since the model studies only a fragment of reality, which always is more complex and broader than the model. To be aware of the reality in its essential aspects, to isolate the correct fragment with respect to the question field, it is necessary to have a valid and exhaustive perception. In this, the demander plays a dominant role.

Finally, the scientist's function is to build the model and to draw from it conclusions that are intelligible to the decision maker and that can orient his action. His success in this depends very much on the way in which, in relation to the demander, he defines the model, refines the problem formulation, and chooses the operational attitude. Will he progress from the set embracing the only feasible exclusive actions to a statement of the "best" action or of a group of dominating actions? If the particular formulation chosen (for example, in a credit demand) leads to retaining not one unique action but several (without the number being too imposing), will he classify (in decreasing order) all the nonexclusive actions contemplated, or will he construct a decision tree leading to decisions of the type "accept," "reject," "demand complementary information"? Will he agree to give up the idea of comparing any two actions, or will he undertake an immediate line towards classical optimization? Finally, would he prefer to tackle a more interactive problem seeking to bring to light one or more compromises embraced by a set A of possibilities defined *a priori*, or would he wish to consider also the genesis of the actions and "negotiation" that lead to reconsideration of the limits of feasibility?

In summary, *Decision-Aid refers to the activity of a scientist who tries, by means of more or less formalized models, to help a decision maker to improve his control (this word having its cybernetic connotation) of the decision process*. To "improve" in this context means to increase the coherence between the evolution of the process and the different objectives intervening in it. This includes, among other things, eliciting the objectives, clarifying their antagonisms, and finding implementable solutions which satisfy them. In this perspective, modeling has, first, a passive role in helping the actors to comprehend the phenomena, by the mastery it gives of the various possible actions, and by the reflections it gives of pre-existing preferences; second, modeling has an active role in the sense that the model contributes to the formation and the evolution of the preferences of the different actors on stage, by making them acceptable or by discovering possibilities that were previously rejected or not even considered.

In this paper, we will particularly study questions dealing with

- How to conceive and build a model of the preferences of an identified decision maker, who may not necessarily be a single person (sections 2.1 and 2.2)
- How to use such a model so as to help the decision maker (section 2.3)

The preferences in question are those of the decision maker in connection with feasible actions or, more generally, potential actions (section 2.1.1). Consequences of any of them can be analyzed (by the scientist with the help of the demander) using primary concepts (section 2.1.2); comparison of such actions can then be based on vectors $g(a) = g_1(a), \dots, g_n(a)$ that associate with any potential action a n values, each one corresponding to a particular criterion g_j . The set of the n criteria defines what we will call a *consistent family of criteria* (section 2.1.3).

The heterogeneity of conflicts between criteria, the incomplete knowledge of conditions of substitution between small variations of each one, and the qualitative nature or fuzziness of some of the data entering in their definition are some of the factors that render preference modeling particularly difficult (section 2.2.1). Considering those difficulties, it seems necessary to introduce *a priori* four fundamental exclusive situations in modeling of preferences (Table 2.1). More precisely, as a starting point for a prescriptive theory of Decision-Aid we will set the following basic axiom, which seems to be as unrestricted as possible.

FUNDAMENTAL PARTIAL COMPARABILITY AXIOM Preferences can be modeled by means of four binary relations I , P , Q , and R , having the following properties¹:

- I (indifference): reflexive and symmetric
- P (strict preference): irreflexive and antisymmetric
- Q (large preference): irreflexive and antisymmetric
- R (incomparability): irreflexive and symmetric

Moreover, exactly one of $a'Ia$, $a'Pa$, aPa' , $a'Qa'$, aQa' , and $a'Ra$ holds for every potential action a and a' .

Classical decision theory excludes incomparability and large preference since it is based on the following, more restrictive axiom.

COMPLETE TRANSITIVE COMPARABILITY AXIOM Preferences can be modeled by means of two binary relations I and P having the following properties:

- I (indifference): reflexive, symmetric, and transitive
- P (strict preference): irreflexive, antisymmetric, and transitive

Moreover, exactly one of:

$$a'Ia, a'Pa, aPa'$$

holds for every potential action a and a' .

¹ Terminology is that of Fishburn (1970a, pp. 10–11).

TABLE 2.1 Situations to Which the Comparison of Two Potential Actions a, a' May Lead ($a \neq a'$)

Situations	Definitions
<i>Four fundamental exclusive situations</i>	
Indifference: $a' I a$ & $a I a'$	The two actions are indifferent in the sense that there exist clear and positive reasons to choose equivalence; <i>example</i> : $g_j(a) = g_j(a') \forall j$, some of the equalities not being rigorous but only approximate
Strict preference: $a' P a$ or $a P a'$	One of the two actions (which one being known) is strictly preferred to the other; <i>example</i> : $g_j(a) = g_j(a') \forall j \neq k, g_k(a') - g_k(a)$, a significant difference
Large preference: $a' Q a$ or $a Q a'$	One of the two actions (which one being known) is not strictly preferred to the other, but it is impossible to say if the other is strictly preferred to or indifferent from the first one because neither of the two former situations dominates; <i>example</i> : $g_j(a) = g_j(a') \forall j \neq k, g_k(a') - g_k(a)$, neither sufficiently small to justify indifference nor sufficiently large to justify strict preference
Incomparability: $a' R a$ & $a R a'$	The two actions are not comparable in the sense that none of the three former situations dominates; <i>example</i> : $g_j(a) > g_j(a')$ for $j = 1, \dots, p, g_j(a') > g_j(a)$ for $j = p + 1, \dots, n$, the majority of the differences being significant
<i>Two important regroupings</i>	
Presumed preference: $Q \cup I$	This excludes the strict preference and incomparability situations, and consequently embraces indifference and large preference situations be they separated or only assumed separable; <i>example</i> : see Tables 2.5 and 2.6 (prescription concept)
Preference: $Q \cup P$	This covers the two situations of strict and large preference separated or assumed separable and consequently excludes indifference and incomparability; <i>example</i> : see Tables 2.5 and 2.6 (condition 2 and the quasi-criterion concept)

Let us observe that, for real-world problems, this latter axiom implies¹ (and vice versa) the existence of what we will call a *value function*² $V_A(a)$ defined on A such that:

$$V_A(a') = V_A(a) \Leftrightarrow a' I a \quad \text{and} \quad V_A(a') > V_A(a) \Leftrightarrow a' P a.$$

There exist many problems for which the most appropriate preference modeling is provided by an adequate expression of such a value function based on n criteria:

$$V_A(a) = V_A [g_1(a), \dots, g_n(a)].$$

As will be shown in section 2.2.1, there are also many problems for which multicriterion Decision-Aid does not fit in with the assessment of such a value function. An alternative possibility of preference modeling will be described in sections 2.2.2 and 2.2.3. It is especially appropriate when large preference and incomparability cannot be excluded *a priori* and when indifference and strict preference are not necessarily transitive.

In section 2.3, we will show how a partial and fuzzy knowledge of preferences can be made to conform to the fundamental partial comparability axiom (but not necessarily to the complete transitive comparability axiom) and can be made operational for Decision-Aid. Three types of problem formulation will be studied.

2.1 WHICH ACTIONS ARE TO BE COMPARED AND ON WHAT BASIS?

2.1.1 POTENTIAL ACTIONS AND THE PROBLEM FORMULATION

Usually, the scientist orients his modeling work toward the elaboration of

- Alternatives, conceived as mutually exclusive, each one representing a global action that describes, in an extensive way, every aspect of the decision
- A set A embracing all imaginable global actions that are surely implementable (usually called feasible alternatives) – this *a priori* delimitation is based on the existence of a rigid objective frontier separating the admissible and inadmissible

However, there may be problems for which it is futile or simply awkward to use such a set as a starting basis for Decision-Aid. First, the frontier between the acceptable and the unacceptable is often fuzzy. Sometimes this depends on the nature of the boundaries. In other cases, it is the diagnosis of acceptability in its globality that will create the problems, because of the complex arrangement of

¹ This implication is not true in general, but the additional condition existence of a countable subset of A P -order-dense in A given in Fishburn (1970a, theorem 3.1) is always verified in practice.

² So as to avoid confusion with the utility function in the von Neumann sense, we do not use the term utility here: $V_A(a)$ may be quite inappropriate to mathematical expectation calculations.

		The elements of A are mutually exclusive	
		YES	NO
The set A is <i>a priori</i> defined in a strict and exhaustive manner (by a rigid frontier, a non- ambiguous test of mem- bership, and so on)	YES	Case globalized and stable	Case fragmented and fixed
	NO	Case globalized and evolutionary (or flexible)	Case fragmented and evolutionary (or flexible)

FIGURE 2.1 Four cases for the modeling of the set A of potential actions.

the diverse fragments constituting the envisaged actions. Second, insufficient performance brought to light by a preliminary calculation, the clash of ideas between the principal actors in the decision process, and simply the impossibility of imagining beforehand all the possible actions, are all circumstances that lead to the evolution of the set A (see Figure 2.1).

Moreover, let us point out that analysis of the subject matter of the decision often brings out the artificial and uselessly complicated character of a conception that necessitates the definition of mutually exclusive actions. Many false problems are born from this conception. Let us consider, for example, the decision regularly taken in a bank in relation to requests for credit or in a private firm in relation to the remuneration of personnel or by a panel in connection with the granting of a diploma. When the actions are not naturally exclusive, we may seek to determine those configurations or fragments that are. Thus we are led to substitute for the natural set A of elementary compatible actions, a subset of $\mathcal{P}(A)$ (set of all subsets of A), the elements of this subset appearing as global actions pairwise incompatible. By doing this we are taking the risk of encountering difficulties (occasionally insurmountable) in delimiting the subset of $\mathcal{P}(A)$ of acceptable configurations (feasible alternatives).

The important point in connection with the set A is that the potential¹ actions in the context of a given stage in Decision-Aid are clearly identified. This by no means signifies that the actions are mutually exclusive or independent but that they may be considered separately from one another without becoming devoid of meaning. This does not mean either that they are all immediately acceptable; there is nothing binding, and some may be considered unacceptable at a subsequent stage.

¹ I feel that the terms "action" and "potential" are more appropriate respectively than "alternative" and "feasible" or "admissible," which seemed to be too strongly related to case A globalized for the former and to case A fixed for the latter.

Depending on the problem studied, A may be defined (modeled)

- By a list that very precisely identifies each potential action (e.g., the siting of a factory, a research project)
- By a generator enabling systematic generation (at least in theory) of all potential actions (e.g., demand for credit, work planning)
- As the solution set of a series of conditions or constraints, expressed mathematically, on the characteristics of the potential actions (e.g., product mix, investment plan)

There are two fundamental modeling options that have to be clarified: the conception of the set of actions (discussed above) and the choice of problem formulation. For this latter choice, the scientist has to take into account the level of intervention of the model and its actual stage of development. Table 2.2 lists three types of problem formulation.

It is often thought that problem formulation α is the only natural one. The unique quality of the final decision in the case of A globalized has come to reinforce this belief.

By experience we know how difficult it is for a scientist to convince the principal actors in the decision-making process that the optimal solution in keeping with his model is the one that should be adopted. Moreover, this particular problem formulation α ceases to be self-evident when A is evolutionary or fragmented. The scientist may then consider either problem formulation β or γ (see Table 2.2). More details on each one will be given in section 2.3.

This double option (see Figure 2.1 and Table 2.2) leads to $4 \times 3 = 12$ cases, each corresponding to a real situation. A superficial analysis may leave us with the impression that the globalized cases imply the α type of problem formulation. In actual fact, they do not, as we will see in section 2.3. The fragmented cases do

TABLE 2.2 Types of Problem Formulation on A

Type of Problem Formulation	Objective of the Problem	Output of the Model
α	To help to choose one action considered the "best" among those studied	A choice or a selection procedure
β	To help to sort out all those actions that seem "good" among those studied	A sorting or a segmentation procedure
γ	To help to rank in a decreasing order of preference the actions that seem the "best" among those studied	An ordering or a ranking procedure

not exclude problem formulation α , since Decision-Aid can then proceed by successive iterations, each consisting of the selection of a "best fragment."

In the progressive development of the analysis, there may be successive problem formulations and successive definitions of the sets of potential actions. Each of these successive problem formulations, which is a guideline for discussion and gathering of the data, critically influences the adoption (or rejection) of the study by the principal actors intervening in the decision-making process. Therefore, at each step, the problem formulation has to be determined in connection with what can be understood and accepted by the principal actors so that the scientist can make a useful contribution to the decision process.

Regardless of the nature of A and the associated problem formulation, it is clear that Decision-Aid assigns a fundamental role to the notions of best, worst, good, and bad. It is for this reason that Decision-Aid is not easily separable from a reference to one or more scales of values or even thresholds. Scales or thresholds relative to whom? Relative to the decision maker in the sense laid down above. This means that Decision-Aid is very rarely conceivable without agreeing (provisionally) to "play the game" of a certain decision maker. The scientist can do this by treating the global preference modeling problem not only for the decision maker, but *successively* for several of the actors in the decision process. In reality he is often tempted to seek refuge in a pretended neutrality in order to evade the inherent difficulties of identifying the decision maker in whose name, or for whom, he is working. In so doing, he generally assumes a confused position that makes him run the risk of treating a problem different from the one in question. In fact, the notions of best, worst, good, and bad rarely have an absolute objective sense, and it is unreal, I believe, to talk about preferences without specifying the actor who expresses these preferences and seeks to have them accepted in the decision-making process. According to whether these preferences have been more or less faithfully represented, the quality of the help that this model can give will change.

Nevertheless, the analysis of the elementary consequences of the diverse potential actions can generally proceed independently of the chosen decision maker. But then the scientist should clearly try to disassociate

1. The formal description of all the elementary consequences that at least one of the actors may wish considered. [In doing this, he will have to try to synthesize evaluations by using a consistent family of criteria that is acceptable and comprehensible to all (this will be the subject of the remainder of section 2.1).]

2. The modeling of global preference, taking into account the decision maker's personality. (He will have to try to do this according to the operational attitude that seems to him to be the most effective in the decision process.)

2.1.2 THE PRIMARY CONCEPTS USED IN CONSEQUENCE ANALYSIS

Even relative to a clearly identifiable decision maker (a manager, a selection committee, a community), the consequences of a potential action a , on which this

action is supposed to be judged (with a view to comparing it with others eventually) will appear at first sight imprecise, badly differentiated, multiple, and confused. For this reason we call this complex reality *the cloud of consequences* of the action a , and denote it by $\nu(a)$.

The scientist, with the help of the demander, must therefore devote himself to analyzing and modeling in order to construct an abstract representation of $\nu(a)$ that integrates all the relevant consequences needed for the assessment of global preferences. The elaboration of such a model is generally based on several primary concepts. I have attempted to define these concepts in Tables 2.3 and 2.4 so that they underlie a coherent methodology that is as general as possible. More details and illustrations are given in Roy (1976; in press).

The personality of the actors, the nature of the potential actions and scales, and the mode of elaboration of the state and modulation indicators are the basis of diverse types of frequently intermingled thresholds (see Table 2.5). Consider, for example, a situation in which different actors are indifferent to two actions leading

TABLE 2.3 From Elementary Consequences to Valuations in the Analysis of $\nu(a)$

Concepts and Notations	Definitions
Elementary consequence	Aspect or attribute of $\nu(a)$ considered pertinent to the problem and for which the possible states can be evaluated on a <i>dimension</i> by a state <i>indicator</i>
Dimension	Common feature of the set of states associated with an elementary consequence determining a complete order and destined to justify their comparison in relation to preferences
State indicator $\gamma_i(a)$	Process that is operational and homogeneous from the point of view of comparison used by the scientist to identify, in relation to the dimension i , the state or states to which the potential action a may lead. Formally we set $\gamma_i(a) \subset E_i$ (<i>scale</i> associated with the dimension i)
Scale E_i	Completely ordered set taken as the formal representation of the state set associated with dimension i
Grade e	Element of a scale representing a state relative to the corresponding dimension
$< i$	Order relation translating on E_i the inherent order in the dimension i
Set $\nu = \{1, \dots, \bar{n}\}$ of dimensions	List of dimensions considered necessary and sufficient (for the problem) to make the description of $\nu(a)$ realistic and complete on the basis of corresponding state indicators, possibly completed by <i>modulation indicators</i>
Modulation indicator $\delta_i(a)$	Complementary information about $\gamma_i(a)$ when the valuation is <i>non-single-point</i> on the dimension i (see Table 2.4)
Valuation of a on the dimension i	$\gamma_i(a)$ if $\gamma_i(a) \in E_i$: the valuation is then said to be <i>single-point</i> ; $[\gamma_i(a), \delta_i(a)]$ if $\gamma_i(a) \subset E_i$: the valuation is then said to be <i>non-single-point</i>

TABLE 2.4 Nature of the Modulation Indicators Used in Non-Single-Point Valuations

Most Usual Cases	$\delta_i(a)$
Distributional (von Neumann–Morgenstern utility theory)	Distribution defined on $\gamma_i(a)$ used by the scientist to quantify the relative importance of the different states (according to the size of the population concerned, to a degree of fuzziness of membership, in a probabilistic sense, with respect to dates, etc.)
Relational (Arrow social welfare theory)	Number of vectors associated with $\gamma_i(a)$ used by the scientist to establish a relation (preference, indifference, incomparability) between $\gamma_i(a)$ and $\gamma_i(a')$ for each potential action a' (based on modulation of importance, of likelihood, and so on, between the states of each of these two subsets)
Single “indexed event” (game theory)	Mapping from \mathcal{E} (set of exclusive events) onto $\gamma_i(a)$ used by the scientist to characterize the state $\gamma_i^f(a)$ to which event $e \in \mathcal{E}$ leads; to each event of the class \mathcal{E} , $\delta_i(a)$ then associates a single point valuation. If \mathcal{E} is provided with a probability distribution, $\delta_i(a)$ then defines a probability distribution on $\gamma_i(a)$
Complex “indexed event” (scenarios method)	Mapping from \mathcal{E} (set of events) into $\mathcal{P}[\gamma_i(a)]$ [set of parts of $\gamma_i(a)$] used by the scientist to characterize those states to which each of the events of the class \mathcal{E} may lead, this mapping being eventually enriched by a distribution or relational modulation when the image in $\mathcal{P}[\gamma_i(a)]$ is a subset containing at least two elements of $\gamma_i(a)$

to the same valuations, except on one dimension (for example, on the average operational cost, for which the valuations are e and $e - \eta$). This indifference may have several different explanations:

η is a negligible sum in comparison with the sums at stake elsewhere and with the sensitivity of each actor in this dimension.

η is too low a sum in view of the techniques used for the data collection.

η is a nonsignificant sum in view of the risks that the mode of calculation sets aside.

To illustrate the use of Table 2.5, let us assume that two actions have identical valuations except for dimension i , which is a financial cost dimension. Let the valuations be e and $e - \eta$.

By definition (Table 2.5), $s_i^+(e)$ is the maximum value of η such that $e - \eta$ is not recognized as significantly better than e . For $\eta \leq s_i^+(e)$, the scientist may consider either that $e - \eta$ has presumed preference to e , or (more simply) $e - \eta$ is indifferent from e [$s_i^+(e) = q_i^+(e)$].

To avoid giving a discriminating role to differences that are scarcely significant, the scientist will sometimes be led to pay particular attention to such thresholds in the neighborhood of the goal and, for example, he might define an interval [s_i', s_i'']

TABLE 2.5 Other Information Specifying the Significance of the Evaluations with a View to a More Synthetic Modeling of $\nu(a)$

Concepts and Notations	Definitions
Goal o_i	Grade of E_i such that $\forall e, e' \in E_i$ e' is preferred to or is indifferent from e when $e < i e' < i o_i$ or $o_i < i e' < i e$
Threshold of indiscrimination	Maximum interval between 2 grades (of the same scale) indiscriminationed by the actors who do not consider them as really distinct; it may vary along the scale
Threshold of imprecision	Maximum interval between 2 grades (of the same scale) for which the imprecision of the state indicator does not allow the two to be separated for certain; it may vary along the scale
Threshold of unforeseeableness	Maximum interval between 2 grades (of the same scale) for which the reliability of the anticipation does not allow the two to be distinguished for certain; it may vary along the scale
Threshold of presumed preference $s_i^+(e)$	Generic term used for one, or a mixture of the preceding thresholds such that e' is strictly preferred to e when $e < i e' < i o_i$ or $o_i < i e' < i e$ and that the interval $[e, e']$ (defined by reference to a measure: e.g., number of grades) is strictly greater than (in absolute value) $s_i^+(e)$; for a smaller interval there is a situation of presumed preference that includes situations of indifference and large preference (Table 2.1)
Threshold of indifference $q_i^+(e)$; $q_i^-(e) \leq s_i^+(e)$	Maximum interval between 2 grades of E_i such that e' is indifferent from e when $e < i e' \leq i o_i$ or $o_i \leq i e' < i e$ and that the interval $[e, e']$ (defined by reference to a measure) remains strictly less than (in absolute value) $q_i^+(e)$; for a larger interval, there is large or strict preference
Modular informational relation from the dimension h to the dimension i	The precision of a state $e_h \in \gamma_h(a) \subset E_h$ leads to a modification of the modulation $\delta_i(a)$ relative to $\gamma_i(a) \subset E_i$
$\delta_i(a, e_h)$	Modulation indicator on the dimension i conditioned by e_h
$\delta(a)$	Global indicator integrating all the modular informational relations

(containing o_i) for which all the states falling within this interval will be judged as “good” since they are sufficiently close to the goal.

2.1.3 THE CONCEPT OF A CONSISTENT FAMILY AND THE UNDERLYING NATURE OF THE CRITERIA CONSTITUTING IT

When $|\nu| = \bar{n} > 1$ or when the unique valuation is not a single point¹ the description of $\nu(a)$ obtained

¹ In this latter case, using the complete transitive comparability axiom, von Neumann–Morgenstern utility theory provides a solution for transforming the non-single-point valuation into a measurable criterion (see below).

$$[\gamma_i(a), \delta_i(a)] \quad \forall i \in \nu$$

merits a slight transformation so as to be more manageable, as much for global preference modeling as for Decision-Aid.

This transformation consists of elaborating what we call a *consistent family F of criteria* (see Table 2.6).¹ It is important to note initially that the correspondence between criteria of the family and dimensions retained in the analysis is simple (see, in particular, Table 2.6 “single-point equivalent on the dimension i ”) only in the case where the criterion g_k brings into play indicators relative to a single dimension. When this is the case for all criteria, the passage from thresholds relative to the scales to those of the same nature relative to the criterion k [denoted by $s_i^+(x)$ and $q_i^+(x)$, respectively] presents no major difficulties. In the case of subaggregates, this passage may be a little more complex. Finally, if $f(x)$ is any increasing function, the substitution in F of $f[g_k(a)]$ for $g_k(a)$ allows us to define a new consistent family for the problem.

According to the discriminant power recognized for the criterion k , we define (see the end of Table 2.6):

- *Pseudocriterion* (most general case): if it calls into play an indifference threshold $q_k^+(x)$ and a threshold of presumed preference $s_k^+(x)$, $s_k^+(x) \geq q_k^+(x)$
- *Semicriterion*: a pseudocriterion for which $q_k^+(x) = s_k^+(x)$
- *Precriterion*: a pseudocriterion for which $q_k^+(x) = 0$ or is not defined
- *True criterion*: a pseudocriterion for which $q_k^+(x) = s_k^+(x) = 0$ (every difference is significant)

That these thresholds cannot be any function of x is indicated in Table 2.6 for a threshold of presumed preference, and this remains true for an indifference threshold. This is quite simply explained by the fact that, for $y > x$, there cannot exist (without inconsistencies) a value z of g_k such that

$$y + s_k^+(y) < z \leq x + s_k^+(x).$$

On studying the underlying structure of each one of these types of criterion, it is easy to deduce that we are concerned with

- A linear order for a true criterion
- A semiorder for a semicriterion
- What appears to be an *oriented semiorder* for a precriterion
- A more complex structure for a pseudocriterion, which we shall call a *pseudo-order*.

In what follows, a *semiorder* is characterized by the definition of two relations I and P such that

¹ The notation F designates the family of criteria as well as the set $1, 2, \dots, n$ of indices.

TABLE 2.6 Modeling $\nu(a)$ on the Basis of a Consistent Family of Criteria

Concepts and Notations	Definitions
Criteria vector $g(a) = g_1(a), \dots, g_n(a) \in R^n$	Exhaustive résumé (for the problem) of $\nu(a)$ given by the n values assumed, with regard to action a , by the criteria g_j $j = 1, \dots, n$ forming a <i>consistent family</i> relative to the \bar{n} dimensions considered
Consistent family F of criteria g_j $j = 1, \dots, n$ or $j \in F$	A family of n functions (called criteria) subject to three conditions: <ol style="list-style-type: none"> 1. Exhaustivity condition: the $g_j(a)$ are real-valued functions, arguments of which are the state and modulation indicators constituting the valuations of a on the \bar{n} dimensions; they are defined in such a way that $g_j(a) = g_j(a')$ $j = 1, \dots, n \Rightarrow a$ is indifferent from a'; 2. Monotonous comparability condition: if a and a' are two actions such that $g_j(a) = g_j(a') \forall j \neq k$ and $g_k(a) > g_k(a')$; then a' is preferred to or is indifferent from a (see Table 2.1); 3. Nonredundancy condition: dropping any one of the g_j of the family invalidates one or more of the preceding conditions for a pair of actions (a, a') real or fictitious
$g_j(a) = \gamma_j(a)$	This implies: The valuation on the dimension j is single point $\forall a \in A$ o_j is the highest grade of E_j for which grades are identified by figures
Single-point equivalent on the dimension i	The valuation on the dimension i is not single point (at least for one action), but it occurs only in a single criterion, which is justified by the existence of a single-point equivalent (e.g., average value, certainty equivalent, realized value) substitutable for the couple state indicator, modulation indicator
g_j : subaggregate of dimensions i_1, \dots, i_p	g_j appears as a résumé of the valuations relative to the dimensions i_1, \dots, i_p
Explosion of the dimension i	The valuation on the dimension i intervenes, by at least one of its indicators, in more than one criterion
g_k is a true criterion	If the condition 2 above implies strict preference (indifference and presumed preference being excluded)
g_k is a precriterion	If the condition 2 above involves, besides strict preference, presumed preference situations that can be characterized as follows by a threshold function $s_k^+(x)$: Presumed preference if $g_k(a) = x < g_k(a') \leq x + s_k^+(x)$ Strict preference otherwise So as not to lead to inconsistencies, $s_k^+(x)$ must also satisfy: $\frac{s_k^+(x) - s_k^+(y)}{x - y} > 1$ where x, y are possible values for the precriterion g_k

TABLE 2.6 (continued)

Concepts and Notations	Definitions
g_k is a semicriterion	<p>If the condition 2 above involves, besides strict preference, indifference situations that can be characterized as follows by a threshold function $q_k^+(x)$:</p> <p style="padding-left: 40px;">Indifference if $g_k(a): x < g_k(a') \leq x + q_k^+(x)$ Strict preference otherwise (large preference here is excluded)</p> <p>So as not to lead to inconsistencies $q_k^+(x)$ must also satisfy the condition for a precriterion, given above</p>
g_k is a pseudocriterion	<p>If it is a precriterion for which presumed preference involves, besides large preference (see Table 2.1), indifference situations that can be characterized as follows by a threshold function $q_k^+(x) \leq s_k^+(x)$:</p> <p style="padding-left: 40px;">Indifference if $g_k(a) = x < g_k(a') \leq x + g_k^+(x)$ Large preference if $x + q_k^+(x) < g_k(a') \leq x + s_k^+(x)$</p> <p>Here $q_k^+(x)$ must satisfy the same condition as $s_k^+(x)$</p>

I is reflexive and symmetric (which corresponds to indifference)

P is an antisymmetric "complement" of I in the sense that one and only one of the following three possibilities holds $\forall x, y: xIy, xPy$, or yPx (i.e., strict preference)

$PIP \subset P$ (implies the transitivity of P)

$P^2 \cap I^2 = \emptyset$ [for further details, see Fishburn (1970a) or Jacquet-Lagrange (1975a).]

In order to complete an elucidation of the use that he may make of the criterion k , the scientist must investigate the relations that connect any two intervals of the type

$$w_k = [x_k, x_k + \omega_k] \quad \text{and} \quad w'_k = [x'_k, x'_k + \omega'_k]$$

defined by two ordered pairs (a, b) and (a', b') of potential actions such that

$$g_j(a) = g_j(b) = g_j(a') = g_j(b') \quad \forall j \neq k, \quad g_k(a) = x_k, \quad g_k(a') = x'_k$$

$$g_k(b) - g_k(a) = \omega_k \geq 0, \quad g_k(b') - g_k(a') = \omega'_k \geq 0.$$

Do such intervals reveal an underlying reality sufficiently to allow assessment, in a significant and operational way, of a comparison between the superiority of b over a and that of b' over a' ? The objective of this comparison is to lead the scientist to opt (as in Table 2.1) in favor of one of the following fundamental exclusive situations:

Superiority identical: $(x_k + \omega_k)$ differs from x_k exactly as $(x'_k + \omega'_k)$ differs from x'_k

Superiority strictly greater: $(x_k + \omega_k)$ differs from x_k strictly more than $(x'_k + \omega'_k)$ differs from x'_k

Superiority weakly greater: $(x_k + \omega_k)$ differs from x_k at least as much as $(x'_k + \omega'_k)$ differs from x'_k but it is impossible to say if it is strictly or exactly

Superiority incomparable: neither of the three former situations dominates

These considerations lead us to formulate the following question:

Q_1 How can one discriminate among the preceding four fundamental mutually exclusive situations so as to compare the "importance" of any two intervals of the type w_k and w'_k ?

When one of the two intervals is null, the reply to this question has already been given through the concepts of thresholds (which may depend on the abscissa x of the non-null interval). Thus it is with the other cases with which we are now concerned.

Most often the scientist is led to admit implicitly that the reply is given independently of x_k and x'_k by a simple examination of the sign of $\omega_k - \omega'_k$. Frequently he goes as far as treating the ratio ω_k/ω'_k as a measure of the superiority of b over a when that of b' over a' is taken as unit. It is clear that there is a very strong hypothesis that makes the criterion k appear to be a *high-precision instrument*. Not only is g_k a true criterion, but it is self-imposing up to a positive linear transformation; i.e., g_k is a measure (with reference to the set of intervals): only the unit and origin are arbitrary.

If the scientist can define a function $f(x)$ (nondecreasing) for which $f[g_k]$ (substituted for g_k in F) is a measure, then we will say that g_k is a *measurable criterion in F* . For such a property to hold, g_k must satisfy axioms 1 through 4 below. But first let us introduce a new definition.

By *discriminating interval* we will refer to an interval of the type $w_k = [x_k, x_k + \omega_k]$ such that b is strictly preferred to a .

AXIOM 1 Any non-null interval is a discriminating interval (g_k is a true criterion).

AXIOM 2 The reply to Q_1 is independent of the values $g_j(a) = g_j(a') = g_j(b) = g_j(b')$, $j \neq k$, whatever the pairs a, b and a', b' may be.

AXIOM 3 The reply to Q_1 excludes superiority incomparable.

AXIOM 4 On the subset of discriminating intervals, the reply to question Q_1 excludes superiority weakly greater and leads to transitive answers compatible with inclusion and union of the intervals, for superiority identical as well as for superiority strictly greater; consequently, the two binary relations \sim^* and $>^*$ so defined are in conformity with the complete transitivity axiom (notations used by Fishburn, 1970b).

These four axioms do not imply measurability, as the reader may easily verify. When the set of possible values of g_k is an interval, a set of axioms necessary and sufficient¹ to imply measurability may be obtained by completing axioms 1, 2, 3, and 4 by the following axiom:

AXIOM 5 For all three values of $g_k: x < x' < y'$, there exists one unique value y of g_k such that the superiority of y over x is identical to that of y' over x' ($[x, y] \sim^* [x', y']$).

Past experience has shown that in a good many real-world problems, it is impossible for the scientist to justify the exact values that axiom 5 postulates (either because there is more than one single value or because none is acceptable to all the actors who intervene in the decision-making process). Reliance on the idea of approximation to justify the arbitrary part included in the selected values (and in order to remain within the framework of the set of axioms) is not always realistic. In fact, this difficulty usually arises because axiom 1 is not operational. It follows that axiom 4 must also be reconsidered.

I suggest that the criteria that satisfy axioms 2 and 3 be called *graduable* and that the term *graduation* be used to designate those (graduable) criteria for which the answer to question Q_1 can be assessed only on the values of ω_k and ω'_k (see the example in Roy, 1976).

The structure introduced (by an axiom similar to axiom 4) on the set of intervals of the type w_k by replies to question Q_1 is evidently intimately related to the techniques used to assess these replies. In the case of graduable criteria, we can characterize the criteria as follows:

- Truly graduable: weak order structure (cf. axioms 1 and 4)
- Semigraduable: semiorder structure
- Pregraduable: oriented semiorder structure
- Pseudograduable: pseudo-order structure

2.2 HOW TO CONSTRUCT A MODEL OF GLOBAL PREFERENCES

The purpose of this section is the description of some of the concepts and techniques that the scientist may use to elicit global preferences on the basis of F enriched with complementary data he may obtain. We emphasize cases in which the underlying nature of the criteria (pseudocriteria, nonmeasurable criteria, and so on) – their heterogeneity or antagonism, the fuzziness of complementary data required for aggregation – *a priori* strengthens the interest for the fundamental

¹ Under the Archimedean condition: $\forall [x', y']$, there exists $\epsilon_{[x', y']} > 0$ such that $y - x < \epsilon_{[x', y']} \Rightarrow [x, y] <^* [x', y']$. The author thanks P. Vincke for having formulated this additional condition and for his contribution to the verification of the exactness of this assertion.

partial comparability axiom and opposes the acceptability of the complete transitive comparability axiom.

2.2.1 COMPLETE OR PARTIAL MODELING OF GLOBAL PREFERENCES

Although Table 2.1 has a general significance, until now the comparison of two potential actions has been studied only in the particular case when $g_j(a) = g_j(a')$ $\forall j \neq k$ and where the analysis prejudges the personality of the decision maker as little as possible. This, together with the fact that the consistent family of criteria must be, as far as possible, comprehensible and acceptable by all the actors in the decision-making process, implies proscribing all premature subaggregates, a source of confusion and contestation. *The comparison according to a single criterion k consequently only summarizes what the analysis has objectively shown on a single dimension, or on several dimensions subaggregated* (because they appear very homogeneous or highly correlated). Now we must pass to a higher level: that of global preferences.

Apart from the relatively exceptional case when the synthetic description of $\nu(a)$ naturally leads to a consistent family reduced to a single criterion, complementary information and reflection are necessary in order to determine the conditions that, on the basis of associated criteria vectors, will allow the scientist to state that *such an action is good or bad, better or worse than another in the eyes of the identified decision maker*. Let us note that the question of knowing whether an action a is good or bad can always be posed in terms of comparison: comparison of a with reference actions (real or fictitious) acting as norms (see section 2.3.2).

To specify the relative importance of the criteria, to elucidate the conditions of substitution between slight variations of one into another of the criteria, to clarify the cases of preferential independence – these are some of the data required by the scientist in order to answer the following question:

Q_2 How can one discriminate among the four fundamental mutually exclusive situations of Table 2.1 when $g_j(a) \neq g_j(a')$ $j \in J \subset F$ and $|J| > 1$?

Most often the scientist seeks a reply to Q_2 which *a priori* conforms with the complete transitive comparability axiom. For reasons given in the introduction he may then consider that the most appropriate modeling of preferences consists in an adequate expression of a value function:

$$V_A(a) = V_A [g_1(a), \dots, g_n(a)] \in R.$$

Such a function appears as a *true criterion aggregating the n criteria of the family F*.

To reply to Q_2 in this way is relatively easy when the n criteria are measurable. In fact, subject to preferential independence of each pair of criteria in F , the work of aggregation practically reduces itself to the determination of substitution rates (see Keeney, 1974; Raiffa, 1969; Ting, 1971). In practice the hypotheses required

by this type of answer are seldom rigorously verified. Moreover, the means generally available for the study do not permit the scientist to ascertain how true the supposed approximation is. In fact, the type of reply to Q_2 that the scientist may formulate as objective depends to a great extent on the underlying nature of the criteria (see section 2.1.3), and to confine oneself *a priori* to complete transitive comparability increases the risk of reaching a dead end. Details (real-world examples, reformulation of Arrow's theorem in a multiple-criterion Decision-Aid context, and the like) on this point can be found in Roy *et al.* (1975).

To end with a formal examination of question Q_2 , let us stress that, in order to overcome the encountered difficulties, nothing from a theoretical point of view precludes the possibilities that:

I and/or P could be nontransitive

V_A could be a precriterion, a semicriterion, or a pseudocriterion

There could exist pairs of actions for which P and I would not be separated

$I \cup P$ could be only a partial binary relation

These are crucial options for the scientist that cannot be discussed independently of the operational approach he chooses or even of the direction in which he expects to steer Decision-Aid.

In many cases it is not possible to build a general aggregation rule. But we can most often make reference to a unique value function V_A : an implicit function of the g_j 's likely in ideal conditions to represent the global preferences of the decision maker. The most widely adopted attitude consists in elucidating such a value function acting as a single true criterion. It has incontrovertibly proved its efficacy (especially when the scientist adopts the problem formulation α on a globalized and stable set A) to such an extent that for many it is the only attitude that comes to mind. However, this attitude is a source of impediment for the scientist who may

For certain pairs of actions, not know how to, not want to, or not be able to compare them (Roy, 1974a)

For rough, qualitative, random evaluations, or evaluations expressed in heterogeneous units (francs, minutes, number of inhabitants, degree of similarity) be in no position to extract a common dimension (Ponsard, 1975)

Under criteria that are more or less correlated, nonmeasurable, or counterbalancing within a complex imprecise logic, not know how to synthesize them in a unique criterion (Bertier and de Montgolfier, 1971)

For an *a priori* delimited set of potential actions with frontiers that are almost artificial in their clarity, not feel capable of appreciating, beforehand and in all their aspects, the structural transformations to be integrated in the definitions of a unique criterion V_A acceptable within A , so as to extend it to the frontier and a little beyond (Theys, 1975)

For an evolutive set A consisting of nonexclusive potential actions and/or a problem formulation for which the objective is not to select directly a unique action, not judge this an appropriate approach (Roy, 1974b)

For these and several other reasons, he may renounce this first approach or wish to make it more flexible, or even to delay its adoption.

2.2.2 OUTRANKING AND FUZZY OUTRANKING RELATIONS

An alternative solution may be to seek a reply to question Q_2 while accepting incomparability situations and clarifying preference and indifference situations only in the cases where the scientist is able to establish them with an objectivity and security that he judges satisfactory. This means, among other things, that he renounces the complete transitive comparability axiom (see the introduction). It is precisely this attitude that was (Roy, 1968) the origin of the notion of outranking relation.¹

The term *outranking* refers to those of the preferences thus modeled; given two potential actions a and a' ,

a' *outranks* a signifies that the scientist has enough reasons (particularly with respect to what $g(a)$ and $g(a')$ really mean) to admit that in the eyes of the decision maker a' is at least as good as a (consequently a' is indifferent from or preferred to a).

a' *does not outrank* a signifies that the arguments in favor of the proposition " a' is at least as good as a ," are judged insufficient; this does not imply that cogent arguments in favor of the proposition " a is at least as good as a' " exist (consequently a is incomparable or preferred to a') (Table 2.1).

Within such a framework, the scientist may be more or less willing (may take more or fewer risks) to accept the outranking, whence the concept of *fuzzy outranking* (Zadeh *et al.*, 1975).

A fuzzy outranking relation S_A^d can be characterized by the definition of a degree of outranking d associating with each couple (a', a) a number $d(a', a)$, where d is a criterion that fixes the more or less high credibility of the outranking of a by a' . More precisely, the degree of credibility must possess the following properties:

1. The number $d(a', a)$ calls into play a' and a only through their evaluations $[\gamma_i, \delta_i] \forall i \in \nu$; generally² we set $d(a', a) = d[g(a'), g(a)]$.

¹ Partial preference relation could be an appropriate alternative term if it did not appear, in the eyes of so many people, so strongly connected with transitivity and with a necessarily non-ambiguous distinction between indifference and strict preference.

² It may be interesting to economize on the definition of F and to establish directly d on the $[\gamma_i, \delta_i]$ [see Jacquet-Lagrange (1975a, b); the adaptation of property 2 raises some rather delicate questions].

2. $d(a', a)$ increases with the reliability of the outranking of a by a' ; thus, in particular, $d(a', a)$ is a nondecreasing function of $g_j(a') \forall j$ and a nonincreasing function of $g_j(a) \forall j$.

3. $d(a', a) = 1$ implies a certain outranking of a by a' , whereas $d(a', a) = 0$ implies either a certain nonoutranking of a by a' or the total absence of arguments in favor of such an outranking; it follows that $0 \leq d(a', a) \leq 1$.

Table 2.7 illustrates several of the consequences of these definitions and properties; Figure 2.2 states the conventions that allow us to associate with S_A^d a graph G_A^d , called an outranking graph (see Figures 2.3 and 2.4).

Let us, as an example, examine what could be the outranking relation associated with a pseudocriterion g . (Here g can be viewed either as the result of the aggregation of all criteria of F or as a particular pseudocriterion of F , in which case all the actions considered have the same value on the other criteria of F .) According to the definition of d and to property 3:

$$\begin{aligned} d(a', a) &= 1 && \text{if } g(a') - g(a) \geq 0 \\ d(a, a') &= 0 && \text{if } g(a') - g(a) \geq s^+ [g(a)] \\ d(a, a') &= 1 && \text{if } 0 \leq g(a') - g(a) \leq q^+ [g(a)] \end{aligned}$$

So the only case that remains nondetermined (see Figure 2.3) deals with the value of $d(a, a')$ when

$$q^+ [g(a)] < g(a') - g(a) < s^+ [g(a)],$$

but from property 2 it follows that $d(a, a')$ increases from 0 to 1 when $g(a')$ decreases from $g(a) + s^+ [g(a)]$ to $g(a) + q^+ [g(a)]$. The remaining indetermination

TABLE 2.7 Connections between Criterion Vectors, Degree of Outranking, and Situations Described in Table 2.1

The Hypotheses	Are Compatible with
$g_j(a') = g_j(a) \ j \neq k$ and $g_k(a') - g_k(a) > s_k^+ [g_k(a)]$	$d(a', a) = 1$ and $d(a, a') = 0$
$g_j(a') = g_j(a) \ \forall j \neq k$ and $0 < g_k(a') - g_k(a) < s_k^+ [g_k(a)]$	$d(a', a) = 1$ and $0 < d(a, a') < 1$
$g_j(a') = g_j(a) \ \forall j \neq k, h$ and $0 < g_k(a') - g_k(a) < s_k^+ [g_k(a)]$ $0 < g_h(a) - g_h(a') < s_h^+ [g_h(a')]$	$0 < d(a', a) < 1$ and $0 < d(a, a') < 1$
$g_j(a') = g_j(a) \ \forall j \neq k, h$ and $0 < g_k(a') - g_k(a) < s_k^+ [g_k(a)]$ $g_h(a) - g_h(a') > s_h [g_h(a')]$	$d(a', a) = 0$ and $0 < d(a, a') < 1$
$g_j(a') = g_j(a) \ \forall j \neq k, h$ and $g_k(a') - g_k(a) > s_k^+ [g_k(a)]$ $g_h(a) - g_h(a') > s_h^+ [g_h(a')]$	$d(a', a) = 0$ and $d(a, a') = 0$
$ g_h(a') - g_h(a) \leq q_j^+ [\text{Min}(g_j(a), g_j(a'))] \ \forall j$	$d(a', a) = 1$ and $d(a, a') = 1$

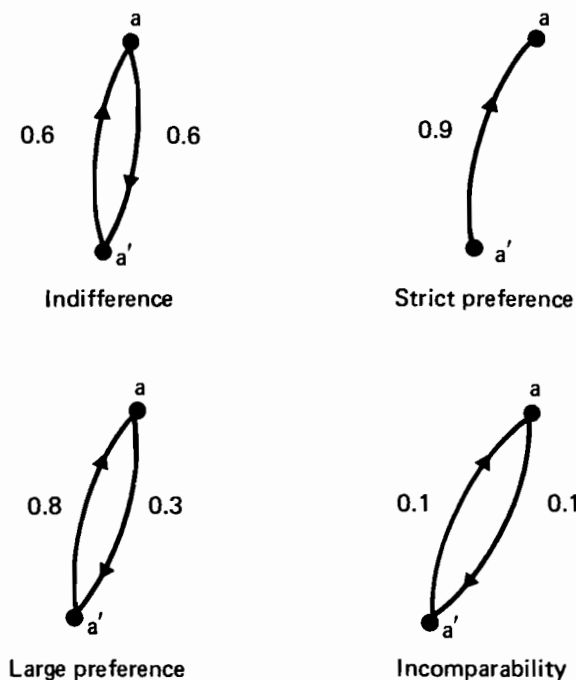

FIGURE 2.2 Examples of configurations that may appear in the graph G_A^d associated with S_A^d . The arcs are oriented according to the order of the actions in the couple considered; the absence of an arc corresponds to a degree of null outranking.

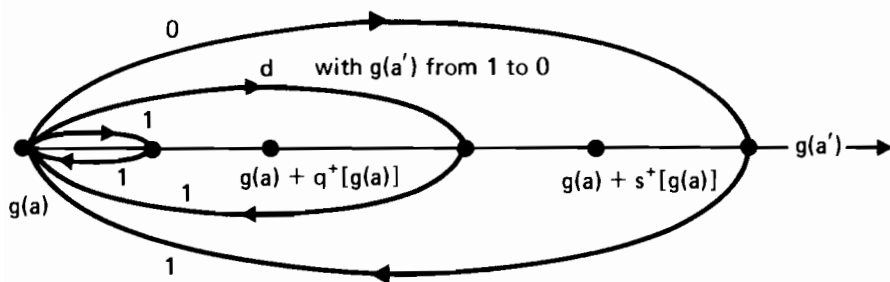

FIGURE 2.3 Fuzzy outranking relationship associated with a pseudocriterion.

of d may then be solved by the adoption of any function having such a property: for instance, a linear interpolation may be chosen. Finally, the following formula synthesizes this discussion:

$$d(a, a') = \frac{s^+[g(a)] - \text{Min}[g(a') - g(a), s^+[g(a)]]}{s^+[g(a)] - \text{Min}[g(a') - g(a), q^+[g(a)]]}.$$

This example shows that the degree of credibility is a different concept from the intensity of preference (Fishburn, 1970a).

It is sometimes reasonable to impose a fourth property on the degree of credibility:

4. Coherence property: $d(a', a)$ must satisfy certain conditions bringing into play the values $d(a, a')$, $d(a', b)$, $d(b, a)$ ($b \in A$). Among the most interesting are

$$d(a', a) \geq d(a, a') \times d(a', b) \times d(b, a) \quad \forall b \neq a', a$$

$$d(a', a) \geq \text{Min}[d(a, a'), d(a', b), d(b, a)] \quad \forall b \neq a', a$$

$$d(a', a) \geq d(a', b) \times d(b, a) \quad \forall b \neq a', a$$

$$d(a', a) \geq \text{Min}[d(a', b), d(b, a)] \quad \forall b \neq a', a$$

Once a fuzzy outranking relation S_A^d is defined, it is often interesting to introduce the outranking relation (nonfuzzy) S_A^λ defined by

$$a' S_A^\lambda a \Leftrightarrow d(a', a) \geq \lambda.$$

Taking into consideration a decreasing sequence of values λ means introducing a nested family of outranking relations (nonfuzzy) that are richer and richer, but more and more risky (insufficiently justified). Inversely, the scientist may be led to build a sequence directly:

$$S_A^1 \subset \subset S_A^2 \subset \subset S_A^3 \dots \quad (\subset \subset \text{ strict inclusion in the set theoretical sense})$$

without the upper indices' referring to a precise value of λ , except for the first, which generally corresponds to $\lambda = 1$. We can always treat such a sequence as a particular form of fuzzy outranking S_A^d in which the credibility criterion d ranges upon a completely ordered discrete set of grades but for which assigning a precise value is useless.

In relations of this type, the degree of credibility appears, since it compels appreciation of the high credibility of outranking, as a not necessarily graduable true criterion.

As property 4, and more generally the last sentence of property 1, underlines, the elements of $A - \{a', a\}$ may be called upon to play a role in the determination of the value $d(a', a)$. In other words, the general context of the set A carries information that the scientist may wish to exploit. This possibility of outranking contingent upon the reference set A conflicts with the independence of the

irrelevant alternatives axiom (Arrow, 1951). For more precision, see Roy (1973), whose Figure 4 illustrates in particular the impoverishing character of this axiom. These aspects will be discussed further in the section on logical extrapolation, below.

2.2.3 CONSTRUCTION OF A RELATION S_A^d

The construction technique must obviously be compatible with, and make the best use of, the properties linked to the nature of the criteria¹ (only pseudocriteria or, contrarily, true criteria; only graduable or, contrarily, measurable criteria, and so on). In particular, it is the case for the five techniques described below; these may be used on their own, or they may be combined.

Compensation

A first series of techniques consists in establishing the outranking of a by a' or its degree of credibility $d(a', a)$ in an attempt to provide a direct answer to the following question:

Q_3 Does the "cumulation" of favorable differences $\omega_j = g_j(a') - g_j(a) \geq q_j^+ [g_j(a)]$ "compensate" in a significant way for the cumulation of unfavorable differences $\omega_j = g_j(a') - g_j(a) \leq -q_j^+ [g_j(a')]$?

More precisely, let us consider the trichotomy of F defined by

$$F(a' \succ a) = \{j | j \in F, 0 \neq g_j(a') - g_j(a) \geq q_j^+ [g_j(a)]\}$$

$$F(a' \prec a) = F(a \succ a')$$

$$F(a' \sim a) = [F(a' \succ a) \cup F(a' \prec a)]$$

The cumulation of favorable differences (introduced in question Q_3) is a quantity of the form

$$\Omega(a' \succ a) = \Omega[\omega_j, j \in F(a' \succ a)].$$

In order to answer Q_3 directly we must define the formula Ω of aggregation of differences and define $d(a', a)$ (or a rule of acceptance of outranking) founded on a comparison of $\Omega(a' \succ a)$ with $\Omega(a \prec a')$, the comparison taking into account the relative importance of the criteria contained in $F(a' \sim a)$.

To illustrate these techniques of compensation, we will cite the technique that we have used to compare different lies for a given highway (Betolaud and Fevrier, 1973). In this problem, as in many others, the introduction of a trade-off ratio s^j ,

¹ This subject, together with the presentation of a precise but nevertheless general enough method for constructing an outranking relation, is treated in Roy *et al.* (1977).

which permits us to assign a precise value to each cumulation of differences by using a formula of the type $\sum_{j \in J} s^j \cdot \omega_j$, runs up against theoretical and practical difficulties. The only significant data we could reasonably hope to obtain were of the type:

- s^1 is certainly greater than 1 and less than 2
- s^2 is close to, and probably slightly less than, 3
- s^3 is of the same order of magnitude as $s^1 + s^2$
- s^3/s^1 can not easily exceed s^4/s^2

Let $S \subset R^n$ be the domain defined by all the data that the scientist can gather in such a context, so that the set

$$\Omega(a' \succ a) = \left\{ \sum_{j \in F(a' \succ a)} s^j \cdot \omega_j / s \in S \right\}$$

delimits, at best, the realistic values of the cumulation of favorable differences, taking into account the imprecise character of even the notion of the trade-off ratio itself and the multiplicity of values that the different actors want to give to those ratios.

The condition of outranking or its credibility may then be defined in many ways, notably by using:

$$m = \text{Min}_{s \in S} \sum_{j \in F(a' \sim a)} s^j \cdot \omega_j, \quad M = \text{Max}_{s \in S} \sum_{j \in F(a' \sim a)} s^j \cdot \omega_j$$

Π = relative weights of the nondiscriminant criteria, i.e., forming $F(a' \sim a)$

Domination Structure

According to Yu (1975) and Yu and Leitmann (1973), a domination factor for $g(a')$ is any vector ω having the following property:

$$\forall \lambda > 0 \quad a' \text{ is preferred to } a \text{ if } g(a) = g(a') + \lambda \cdot \omega.$$

Like Yu, let us call $D(x)$ the family of all domination factors for $x \in R^n$, and $D(\cdot)$ the totality of the $D(x)$ for all x image of a potential action. The definition of such a *domination structure* $D(\cdot)$, or of several solidly established such structures, leads in a natural way to an outranking relation or several nested relations.

Let us add that, in practice, only the knowledge of $D(x)$ for $x = g(a)$ $a \in A$ is necessary, and a limited number of "extreme" domination factors are sufficient to suitably outline $D(x)$, at least under hypotheses little more restrictive than convexity. Finally, under these same hypotheses, there exists a simple polarity relation between substitution vector and domination factor; hence, the possibility of conceiving techniques based conjointly on these last two directions.

Concordance

The trade-off ratios are weights supposed to be defined in such a way that to multiply them by differences of the type $g_j(b) - g_j(a)$ and add the products thus obtained has a significance (see the section on compensation above) for a wide class of differences. Because of this, these ratios vary, except in restrictive hypotheses, with the points $x \in R^n$ from which the differences are calculated [as the cone $D(x)$ depends on x]. When in practice we speak of "weights" that a decision maker accords to such and such a criterion, we refer to something intrinsic that allows us to appreciate the global importance of this criterion in relation to others. It is natural to formalize this notion of weights (importance indicators) by positive numbers p_j defined $\forall j \in F$, which we allow ourselves to combine among themselves (as explained below), but which, because of their global character, cannot be amalgamated with the evaluations.

From such a set of weights p , we may seek to define analogous weights for supercriteria that are the unions of criteria of the type $F(a' \succ a)$, $F(a' \prec a)$ and $F(a' \sim a)$. We will denote them by

$$p(a' \succ a) = p^G, \quad p(a' \prec a) = p^L, \quad p(a' \sim a) = p^I.$$

The simplest form that springs to mind to define the weights p^* of a supercriterion defined by a subset F^* of F is obviously

$$P^* = \sum_{j \in F^*} p_j.$$

It supposes a certain form of independence between the criteria. When this hypothesis is not acceptable, we may seek to correct in the preceding formula over-weighting effects that arise from certain subgroups of criteria, including, for one thing, the same aspect of the cloud of consequences. When we can make the hypothesis that these duplications are proportional to p_j , and thus for each subgroup of criteria, we will be able to adopt the following formula:

$$p^* = P \left[1 - \prod_{j \in F^*} \left(1 - \frac{p_j}{P} \right) \right] \quad \text{where} \quad P = \sum_{j \in F} p_j.$$

Irrespective of the definition adopted, the idea covered by the term *concordance* is the following: the more p^L appears weak compared with p^G , the greater is the concordance of the criteria in favor of the outranking of a by a' . A number of indicators may even be envisaged so as to define a degree of credibility. In Roy (1968, 1972) the reader will find the definitions of those already experimented with through numerous applications within the framework of the method ELECTRE I and II. Others are proposed in Roy (1974a) and Jacquet-Lagrange (1975a, b). The latter has notably described interesting techniques in the case of non-single-point evaluations: these have in particular the merit of allowing us to escape from a formalization of the criteria in the case where this formalization is particularly delicate.

This third technique only partially exploits the information contained in the evaluations, and we shall see, in connection with discordance, that it may be dangerous to base the outranking on concordance alone.

Discordance

Accepting an outranking $a' S_A a$ [likewise the definition of a degree of credibility $d(a', a)$] frequently necessitates paying particular attention to those criteria that are discordant. By that we mean the criteria of $F(a' < a)$ for which the difference $\omega_j(a', a)$ violently opposes (either because it is very large or because, although moderate, it concerns a very important criterion) this outranking $a' S_A a$. One must ask oneself if this difference alone is not of such a nature as to prohibit such an outranking, rather like a powerful opponent in a jury, or an underprivileged minority in a community intervening to stop a decision.

It is certain that, when compensation calculations have been made with sufficient care, we may be justified in proceeding without further examination. However, if such calculations have not been carried out, or if they are far too questionable, we may judge that in certain cases such disagreements can play an obstructing role.

A suitable modeling, which allows the best use of these considerations, consists in a formalization of those pairs of values (x'_j, x_j) that may in certain cases make $a' S_A a$ inadmissible because $g_j(a') = x'_j$ and $g_j(a) = x_j$. Let D_j – called the discordance set – be the set of these pairs for the criterion j . If g_j is a graduable criterion, D_j can be characterized by a limit δ_j to the magnitude of $x_j - x'_j$. For reasons of simplicity and security, we might quite simply decree that, in order to state that $a' S_A a$, it is necessary that

$$[g_j(a'), g_j(a)] \notin D_j \quad \forall j \in F(a' < a).$$

This condition may seem brutal, but it is easy to improve it. These improvements, however, depend on other aspects that intervene in the assessment of the outranking. We may, for example, establish a hierarchy of these discordances by defining for each criterion a sequence of nested subsets (if g_j is a graduable criterion, it can be characterized by $\delta_j < \delta_j^1 < \delta_j^2 < \dots$):

$$D_j = D_j^0 \supset D_j^1 \supset D_j^2 \supset \dots$$

The more the arguments brought to bear, by the other aspects [criteria of $F(a' > a)$] in favor of outranking, are reliable, the more the discordance set, which is to be substituted for D_j in the above condition, must be restricted: if we combine concordance and discordance for relatively small values of the concordance indicator, we shall keep $D_j = D_j^0$; for higher values, we shall replace D_j by D_j^1 ; and so on. The way in which this “parameterization” of the discordance set must be developed evidently depends on the problem and the risks (incomparabilities multiplied to the excess or outrankings rashly accepted) that the scientist tolerates. The reader will find in Grolleau and Tergny (1971) a first utilization of these ideas.

Logical Extrapolation

Let S_A^d be an already built outranking relation. The bringing to light of certain peculiarities (presence of intransitivity or other configurations considered abnormal) may justify a transformation of S_A^d , by the modification of some values of the degree of credibility (or by the addition or removal of arcs in the nonfuzzy case), into another outranking relation. These transformations rest on a logical extrapolation aiming, most often, to satisfy a coherence property (see p. 61 and Roy, 1973).

2.3 HOW TO IMPLEMENT THE INSERTION INTO THE DECISION PROCESS

It is important to note that the preference model, when reduced to a value function, replaces the decision maker in the sense that it dictates the decision to be made. It is a different matter when the model is an outranking relation. How can the scientist use this model to help the decision maker? We attempt to give an answer to this question now by successively reconsidering the three problem formulations of Table 2.2.

We should point out first that S_A^d is a surrogate model to V_A , generally weaker and poorer, built with less effort and fewer hypotheses, but not always allowing a conclusion to be drawn. It is therefore particularly adapted to roughing out a problem, but it may have to be completed by a more thorough analysis of a more restricted problem.

2.3.1 PROBLEM FORMULATION α : TO HELP CHOOSE A BEST ACTION (SELECTION PROCEDURE)

When A is concerned with, for example, variants for highway lies, development plans for a region, new activities for a firm, or even candidates for a well-defined post, the problem may be set in the following terms: to help the choice of one among the actions of A that appears in the eyes of the decision maker as the best.

If, by good fortune, S_A^1 (nonfuzzy relation derived from a supposed previously defined relation S_A^d by fixing $d = 1$) is such that there exists an $a^* \in A$ verifying

$$\forall a \in A: a^* S_A^1 a,$$

it is clear that the scientist may opt to select a^* . In general, S_A^1 will be too weak for such an element to exist. Then he will be able to determine if, for a value $\lambda \neq 1$ that nevertheless reflects a sufficiently significant credibility for the outranking, S_A^λ (see section 2.2.2) admits an element of the type a^* . Finally, if no unique element can be found, he can contribute to the final problem formulation α , which he has decided upon, by searching to determine a subset N of A as limited as possible that has a property analogous to a^* . In doing so, he carries out a dichotomy by putting candidate actions for the first place in N and noncompetitive actions in $A - N$.

By definition, we shall say that $N \subset A$ is an *outranking subset in A* with regard to an outranking relation S_A^λ (not fuzzy) if each action of A not in N is outranked by at least one action of N . In fact, what we are interested in here are the *minimal* outranking subsets (i.e., such that the retraction of any one of the actions they contain makes them lose this property of global outranking). It is clear that such minimal outranking subsets exist regardless of S_A^λ , but they are not necessarily unique.

This multiplicity is evidently very embarrassing for the scientist. It is certain that even the definition of outranking, by restricting the subsequent development of the process (more detailed study, group discussion, the decision maker's judgment, and so on) to any minimal outranking subset N (in other words, by eliminating all the actions of $A - N$), does not run "great risks," in the sense that N almost certainly contains "one of the best actions." This form of reasoning may, however, induce him, when there are many minimal outranking sets, to retain those actions appearing in several of them. But, when he prefers to retain one of the minimal outranking subsets (with a view, for example, to iterating the procedure, as discussed below), he may hesitate on the selection technique. For this selection, he may consider exploiting the idea of internal stability.

A subset of vertices of a graph is said to be *internally stable* when there exists no arc connecting any two of its vertices. Here the property signifies that the actions constituting the subset are each, pairwise, noncomparable. Because of the global character of the outranking of a subset N with respect to its complement $A - N$, the scientist may think it preferable to retain among the minimal dominating subsets those weakest in pairs of comparable actions and, consequently, if there are any, those that are internally stable. Such subsets are called *kernels*.

Let us specify that, if there exist graphs without kernels and graphs admitting several kernels (for more precision, see, for example, Roy, 1969, sections IV.C. and V.C.), there exists a category of graphs (important in the present context) for which the kernel always exists and is unique: these are graphs without circuit (directed cycles). Moreover, only circuits formed from an odd number of arcs imply the nonexistence of a kernel. The scientist must then ask himself if the credibility of such arcs has not been overestimated. Always by logical extrapolation, he may also ask himself if the pairs (a', a) such that

a' does not outrank a [$d(a', a)$ null or too weak]
 $\exists a'' \in A$ such that a' outranks a'' and a'' outranks a

have not given rise to an underestimation of $d(a', a)$. This justifies the use of the concept of quasi kernel proposed in Roy (1974a). From these ideas, Hansen *et al.* (1976) have developed some interesting selection techniques. In a more general way, all these rules of selection are based on the consideration of the following two parameters:

Maximum value of d for which N remains an outranking subset S_A^d

Maximum value assumed by d on the set of pairs formed from distinct actions of N

Having thus selected a subset N^1 such that a_1, a_2, a_6, a_7 form a kernel (Figure 2.4) of S_A^λ for $\lambda = 0.9$, the scientist may judge it too rich and wish to iterate the procedure. He will then be led to study $_{N^1}S_A^d$ (the restriction of S_A^d to N^1). The same selection technique can be conserved, under the condition that the level of exigence is changed. Thus (Figure 2.4), he will select $N^2 = \{a_1, a_6\}$ the kernel of $_{N^1}S_A^\lambda$ for $\lambda = 0.7$, and so on if justified. It is essential, in this type of iteration, to have a good understanding of why the successive eliminations are carried out and thus to better appreciate the nature and importance of the risks taken.

The reader will find in Buffet *et al.* (1967), Guigou (1971), and Roba *et al.* (1970) the analogous steps relative to specific concrete contexts and based on the particularities of the definitions of outranking relations adopted in ELECTRE I (Roy, 1968).

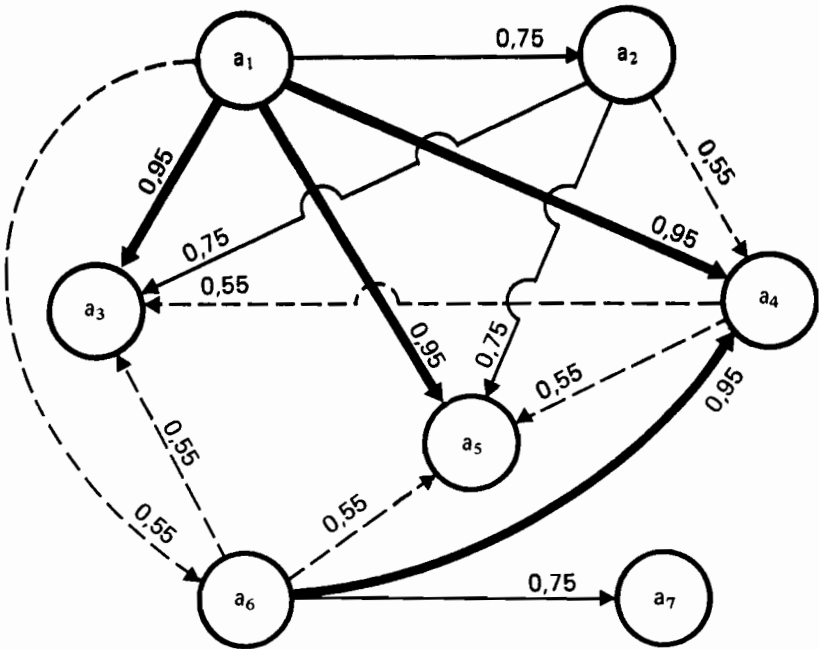

FIGURE 2.4 Value graph representative of a fuzzy relation S_A^d .

2.3.2 PROBLEM FORMULATION β : TO HELP SORT OUT ACTIONS ACCORDING TO INTRINSIC VALUE (SEGMENTATION PROCEDURE)

When the actions of A involve such matters as admitting a candidate into an educational establishment, awarding a diploma, allowing credit, giving a grant or a subsidy, or accepting a minor project or exploratory research and development project, the scientist may, for example, envisage the problem in the following terms: accept all the "sufficiently" good actions, reject all those "far too" bad, and ask for an additional examination of the others. He is then led to use (or to prescribe the use of) a procedure realizing the following segmentation of the set A :

$$A = A_1 \cup A_2 \cup A_3 \quad A_h \cap A_k = \emptyset \quad \text{for } h \neq k,$$

an action $a_h \in A$ being

In A_1 if it merits acceptance without the intervention of the decision maker

In A_3 if it merits rejection without the intervention of the decision maker

In A_2 if it merits an additional examination (e.g., seeking supplementary information, discussion, decision maker's judgment)

In order to find such a trichotomy, the scientist may, for example, seek to characterize a reference situation from combinations of limits on the criteria g_j , indicating the "combined limits" of sufficiently good and sufficiently bad. He can always do this by introducing into A two subsets B and C formed from actions (real or fictitious) each being characterized by a vector in R^n (criterion space) corresponding to these configuration limits of acceptance and rejection. B and C can in certain cases be reduced to a single element. By definition, it follows that

$$B \subset A_1 \quad \text{and} \quad C \subset A_3.$$

A certain coherence is necessary between the definition of these reference subsets and that of the relation S_A^d . The scientist may, for example, impose

$$\forall b \in B, c \in C: d(c, b) = 0 \quad \text{and} \quad d(c, a) \times d(a, b) \times d(b, c) = 0 \quad \forall a \in A.$$

It remains for him to define an assignment rule. There are many possibilities. Among other elements, the scientist may consider the four following parameters:

$$\begin{array}{ll} \text{Max}_{b \in B} d(a, b) = d_1^2 & \text{Max}_{c \in C} d(c, a) = d_3^2 \\ \text{Max}_{b \in B} d(b, a) = d_1^1 & \text{Max}_{c \in C} d(a, c) = d_3^3 \end{array}$$

Figure 2.5 illustrates what such a rule may be. The reader will find in Moscarola and Roy (1977) several methodological developments and the description of two concrete cases (entry into an educational establishment and division of a subsidy).

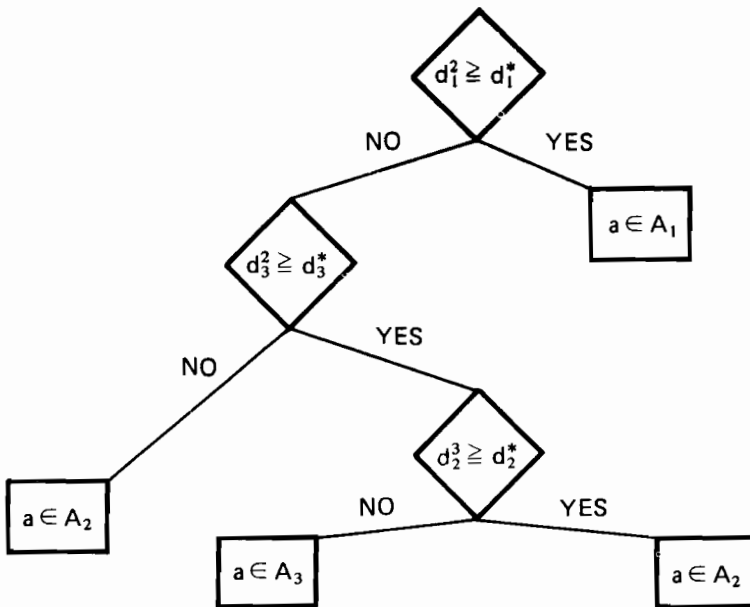

FIGURE 2.5 A rooted tree defining an assignment rule from three thresholds d_1^* , d_2^* , d_3^* .

2.3.3 PROBLEM FORMULATION γ : TO HELP RANK ACTIONS IN DECREASING ORDER OF PREFERENCE (ORDERING PROCEDURE)

The cases are plentiful in which the decision maker, without being constrained to accept only a single action of A , knows beforehand that he must forgo accepting all the good ones. This may be the case when the actions concern, for example, important research and development operations for a firm, regional development projects, equipment conceived to fulfill certain functions, candidates for a series of similar posts, magazines for starting a publicity campaign, or stocks or bonds to be included in an investment portfolio. Here it is the spirit of competition that prevails.

The elements of A must be regrouped into equivalence classes, as small as possible, and these classes must be put in a linear order: i.e., a weak order must be defined on A . It is this weak order that will serve in establishing the final decision. If the modeling of A belongs to the fragmented case, the demarcation line (acceptance/rejection) may be either a matter for arbitration by the decision maker, who will judge its capability of acceptance (financial, physical, psychological,

and so on) or a subject for negotiation, or even for a local study (it should be noted that it is only in this critical zone of demarcation that it is important to have the classes as small as possible). The use of such a linear order can be highly different in the globalized case: considerations arising from the modeling problem may, for instance, lead the decision maker to sequentially examine the elements of A that have been ranked in a "sufficiently good" position (let us remark that the subset of A that he has to consider is not defined on the same principle as the one defined for the purpose of a problematic α).

To give both a rigorous and operational characterization of an unknown weak order P with respect to S_A^d is not an easy thing to do. We might think of calling into play, on the one hand, a set π of weak orders that are *a priori* acceptable (arising from a possible restriction in terms of S_A^d of the set of all weak orders defined on A), or, on the other hand, a distance $d(P, S_A^d)$ defined for all $P \in \pi$ and all S_A^d providing a significant model to appreciate the quality of the approximation of S_A^d by P .

The scientist may then put forward to the decision maker a weak order P minimizing $d(P, S_A^d)$. Nevertheless, he risks running up against a very difficult optimization problem even with a distance as easy to manipulate as the symmetric difference (Barbut, 1966; Heuchenne, 1970; Jacquet-Lagrez, 1969).

There exist, nevertheless, other methods, more empirical and more operational. Let us cite the one proposed in Roy and Bertier (1973) and named ELECTRE II; this is based on outranking relations in which only 2 non-null values of the degree of credibility are allowed. We shall indicate below how, for the example of Figure 2.4, this method may be generalized to the case of any fuzzy relation.¹

The relation (nonfuzzy) $S_A^{0.9}$ produces a subset $B = \{a_1, a_2, a_6, a_7\}$ of four actions for which none is outranked in A with a credibility greater than 0.9. We may consider them as candidates for the first place in a classification P' that is being sought. ${}_B S_A^d$ (restriction to B of S_A^d) may allow us to choose between them. In effect, a_2 and a_7 are both outranked in B with a credibility of 0.75; thus they are eliminated as candidates for the first place. Is it correct to accept a_1 and a_6 *ex aequo*? Admittedly, the outranking of one by the other with a credibility of 0.55 is significant, and we class only a_1 first. If this reasoning is continued on $A - \{a_1\}$, it leads to a study of $B: \{a_2, a_3, a_5, a_6, a_7\}$ and to class second *ex aequo* a_2 and a_6 . We thus construct the weak order

$$P' = \{a_1\}, \{a_2, a_6\}, \{a_4, a_7\}, \{a_3, a_5\}.$$

Before proposing such a weak order to the decision maker, the scientist must examine the weak order P'' constructed following the same principle but proceeding in the opposite direction. The actions of $C = \{a_2, a_3, a_4, a_5, a_7\}$ do not outrank any other with a credibility greater than 0.9. From these candidates for the last place we remove first of all a_2 ($d(a_2, a_3) = d(a_2, a_5) = 0.75$) then a_4 ($d(a_4,$

¹ For more details, see Roy *et al.* (1977, annexe B).

a_3) = 0.55). We are thus left with the last three *ex aequo* which we remove from A in order to find the next to the last. We finally obtain

$$P'' = \{a_1\}, \{a_2, a_6\}, \{a_4\}, \{a_3, a_5, a_7\}.$$

Evidently, there are no more reasons to opt for P' than for P'' . When the two classifications are far too different, it may be much wiser not to retain either of them but to reconsider the problem data. Vice versa, when they are closely related, we may retain an intermediary classification \bar{P} according to the principles adopted for the application of ELECTRE II to media planning (Abgueguen, 1971). In the example above, this leads to putting

$$\bar{P} = \{a_1\}, \{a_2, a_6\}, \{a_4\}, \{a_7\}, \{a_3, a_5\}.$$

In the same vein, many other approaches may be envisaged in order to define a weak order. Finally, let us mention those introduced at Air France (1968) and those proposed by Bernard and Besson (1971). For this third problem formulation more than for the two preceding, much work remains to be accomplished in order to reconcile the simplicity and realism that the user would like with the elegance and rigor that preoccupy the theoreticians.

REFERENCES

- Abgueguen, R. 1971. *La sélection des supports de presse*. R. Laffont, Paris.
- Air France. 1968. Une méthode de classement d'objets en fonction de leurs qualités selon divers points de vue – application au recrutement des hôtesse. Directions de l'Informatique et des Installations Fixes, Recherche Opérationnelle. Paris.
- Arrow, K.J. 1951. *Social Choice and Individual Values*. John Wiley, New York.
- Aumann, R.J. 1962. Utility theory without the completeness axiom. *Econometrica*, Vol. 30, pp. 445–462.
- Aumann, R.J. 1964. Utility theory without the completeness axiom: a correction. *Econometrica*, Vol. 32, pp. 210–212.
- Barbut, M. 1966. Note sur les ordres totaux à distance minimum d'une relation binaire donnée. *Mathématiques et Sciences Humaines*, No. 17, pp. 47–48.
- Bernard, G., and M.L. Besson. 1971. Douze méthodes d'analyse multicritères. *Revue d'Informatique et de Recherche Opérationnelle*, 5ème année, No. V-3, pp. 19–64.
- Bertier, P., and J. de Montgolfier. 1971. Comment choisir en tenant compte de points de vue non commensurables. *Analyse et Prévision*, Vol. 9, pp. 521–548.
- Betolaud, Y., and R. Fevrier. 1973. Conservation des forêts suburbaines et passage des autoroutes – l'exemple du tracé de l'autoroute A86–A87. *Revue Forestière Française*, mai-juin, pp. 179–200.
- Buffet, P., J.P. Gremy, M. Marc, and B. Sussmann. 1967. Peut-on choisir en tenant compte de critères multiples? Une méthode (ELECTRE) et trois applications. *Revue METRA*, Vol. 6, pp. 283–316.
- Fishburn, P.C. 1970a. Utility theory for decision-making. John Wiley, New York.
- Fishburn, P.C. 1970b. Utility theory with inexact preferences and degrees of preference. In *Synthese 21*. Riedel, Dordrecht, pp. 204–221.

- Grolleau, J.L., and J. Tergny. 1971. Manuel de référence du programme ELECTRE II (méthode de classement ELECTRE II en présence de critères multiples). Groupe METRA, Direction Scientifique, Document Technique No. 24. Montrouge, France.
- Guigou, J.L. 1971. On French location models for production units. *Regional and Urban Economics*, Vol. 1, pp. 107–138; 289–316.
- Guigou, J.L. 1973. *Analyse des données et choix à critères multiples*. Dunod, Paris.
- Hansen, P., M. Anciaux-Mundeleer, and P. Vincke. 1976. Quasi-kernels of outranking relations. Proceedings of the Jouy-en-Josas Conference, May 1975. In *Multiple Criteria Decision Making* (H. Thiriez and S. Zionts, eds.). Springer-Verlag, Berlin.
- Heuchenne, C. 1970. Un algorithme général pour trouver un sous-ensemble d'un certain type à distance minimum d'une partie donnée. *Mathématiques et Sciences Humaines*, No. 30, pp. 23–33.
- Jacquet-Lagrez, E. 1969. L'agrégation des opinions individuelles. *Informatiques en Sciences Humaines*, No. 4, pp. 1–21.
- Jacquet-Lagrez, E. 1973. Le problème de l'agrégation des préférences: une classe de procédures à seuil. *Mathématiques et Sciences Humaines*, No. 43, pp. 29–37.
- Jacquet-Lagrez, E. 1974. How we can use the notion of semiorders to build outranking relations in multicriteria decision making. *Revue METRA*, Vol. 3, pp. 59–86.
- Jacquet-Lagrez, E. 1975a. La modélisation des préférences – préordres, quasi-ordres et relations floues. Thesis, Université Paris.
- Jacquet-Lagrez, E. 1975b. Modelling preferences among distributions using fuzzy relations. Presented at the Fifth Conference on Subjective Probability, Utility and Decision Making, Darmstadt, Sept. 1–4, 1975. [In *Decision Making and Change in Human Affairs* (H. Jungermann and G. de Zeeuw, eds.). Reidel, Dordrecht, 1977.]
- Keeney, R.L. 1974. Multiplicative utility functions. *Operations Research*, Vol. 22, pp. 22–34.
- Keeney, R.L., A.W. Drake, and P.M. Morse. 1972. *Analysis of Public Systems*. MIT Press, Cambridge, Massachusetts.
- Le Boulanger, H., and B. Roy. 1970. L'entreprise face à la sélection et à l'orientation des projets de recherche: la méthodologie en usage dans le groupe SEMA. Monographies AFCET Rationalisation des Choix Budgétaires. Dunod, Paris.
- Moscarola, J., and B. Roy. 1977. Procédure automatique d'examen de dossiers fondée sur un classement trichotomique en présence de critères multiples. *RAIRO Recherche Opérationnelle*, No. 2.
- Ponsard, C. 1975. L'imprécision et son traitement en analyse économique. *Revue d'Economie Politique*.
- Raiffa, H. 1969. Preferences for multi-attributed alternatives. Memorandum RM-5868. The Rand Corporation, Santa Monica, California.
- Rivett, P. 1970. The model and the objective function. *Operational Research Quarterly*, Vol. 21.
- Roba, E., B. Sussmann, and M. Theys. 1970. Les méthodes de choix multicritères appliquées à la sélection du personnel. In *Models of Manpower*. The English Universities Press, London, pp. 363–379.
- Roy, B. 1968. Classement et choix en présence de points de vue multiples (la méthode ELECTRE). *Revue d'Informatique et de Recherche Opérationnelle*, No. 8, pp. 57–75.
- Roy, B. 1969. *Algèbre moderne et Théorie des graphes*. Vol. 1. Dunod, Paris. [English version: *Modern Algebra and Graph Theory*, Springer Verlag, Berlin, 1977.]
- Roy, B. 1972. Décision avec critères multiples: problèmes et méthodes. *Revue METRA*, Vol. 11, pp. 121–151.
- Roy, B. 1973. How outranking relation helps multiple criteria decision making. In *Selected Proceedings of a Seminar on Multi-Criteria Decision Making, October 1972*. The University of South Carolina Press, Columbia, pp. 179–201.
- Roy, B. 1974a. Critères multiples et modélisation des préférences (l'apport des relations de surclassement). *Revue d'Economie Politique*, No. 1, pp. 1–44.

- Roy, B. 1974b. La modélisation des préférences: un aspect crucial de l'aide à la décision. *Revue METRA*, Vol. 13, pp. 135–153.
- Roy, B. 1976. From optimization to multicriteria decision aid: three main operational attitudes. In *Multiple Criteria Decision Making* (H. Thiriez and S. Zionts, eds.). Proceedings of the Jouy-en-Josas Conference, May 1975. Springer-Verlag, Berlin.
- Roy, B. In press. A conceptual framework for a prescriptive theory of "decision-aid." *Management Science*, special issue on Multiple Criteria Decision Making.
- Roy, B., and P. Bertier. 1973. La méthode ELECTRE II: une application au media-planning. In *VIIème Conférence Internationale de Recherche Opérationnelle, Dublin* (M. Ross, ed.). OR 72. North Holland, Amsterdam, pp. 291–302.
- Roy, B., M. Blancher, and E. Jacquet-Lagrez. 1977. *Elaboration de critères permettant une intégration de divers aspects liés au temps dans l'aide à la décision en matière de transport*. Vol. 2. DGRST-SAEI, ATP Socio-Economie des Transports, Paris.
- Roy, B., Y. Boulvin, E. Jacquet-Lagrez, M. Blancher, and X. Godard. 1975. *Elaboration de critères permettant une intégration des divers aspects liés au temps dans l'aide à la décision en matière de transport*. Vol. 1. DGRST-SAEI, ATP Socio-Economie des Transports, Paris.
- Theys, M. 1975. For a new definition of the role of operational research in management. In *Proceedings of the First European Congress on Operations Research, EURO I, Brussels, Jan. 27–29, 1975* (J.P. Brans, ed.). North-Holland Publishing Company, Amsterdam, pp. 15–20.
- Ting, H.M. 1971. Aggregation of attributes for multiattributed utility assessment. Technical Report No. 66. Operations Research Center, MIT, Cambridge, Massachusetts.
- Yu, P.L. 1973. Introduction to domination structures in multicriteria decision problems. In *Selected Proceedings of a Seminar on Multi-Criteria Decision Making, October 1972*. The University of South Carolina Press, Columbia, pp. 249–261.
- Yu, P.L. 1975. Decision Dynamics, Persuasion and Negotiation. Research Report CCS 221. Center for Cybernetic Studies, the University of Texas, Austin.
- Yu, P.L., and G. Leitman. 1973. Compromise solutions, domination structures and Salukvadze's solution. *Problems of Control and Information Theory*, Vol. 2, pp. 183–197.
- Yu, P.L., and M. Zeleny. 1975. The set of all nondominated solutions in linear cases and a multicriteria simplex method. *Journal of Mathematical Analysis and Applications*, Vol. 49, pp. 430–468.
- Zadeh, L.A., King-Sun Fu, and K. Tanaka. 1975. Fuzzy sets and their applications to cognitive decision processes. Papers from the U.S.–Japan Seminar, University of California, Berkeley. Academic Press, New York.

DISCUSSION

FISHBURN: In the middle of Table 2.7 you give the case in which a' dominates a significantly in criterion k and a dominates a' in criterion h . In this case you have $d(a, a') = d(a', a) = 0$, and that is of little use. I would imagine that this will be the prevalent situation, and therefore, when you take this into account, there is not much left in the theory to help you when the choice is particularly complex.

JACQUET-LAGREZE: Yes, but in the table, there are only examples of situations that lead to different degrees of outranking. The situations that arise in practice will depend on whether the ranking procedures are fuzzy or not and on how precise these trade-offs are. When those relationships are fairly precise, you will have complete comparability most of the time.

MEYER: Let's compare two situations. The first has $d(a', a) = d(a, a') = 0.9$, and the second has $d(a', a) = d(a, a') = 0.1$. How do one's interpretations about a and a' differ in these two cases?

ROY: In the 0.9 case indifference is almost assured, whereas in the 0.1 case, it is almost a case of incomparability. The 0.1 case does not often occur, but it is important to separate incomparability from indifference.

ZIONTS: Could we say that the outranking relationship means "is probably preferred to"?

ROY: I would not use "probably" because of the connotation of probability. There is no probability value here.

ZIONTS: "Likely" perhaps.

ROY: Yes, that's better.

ZIONTS: Perhaps one could write a computer program with definitions of the a' 's. The output would give you different subsets of incomparable decisions so that when you are finished, you would be able to give the decision maker a set of unoutranked solutions. Have you had any experience with this sort of thing?

ROY: Remember that we do not supply the decision maker with a decision and tell him that it's the best one. This approach should be used as a decision aid. If we were to give the decision maker a lot of outranking subsets, I think he might become confused. The idea is merely to give the best such subset and let him restrict his attention to that. My experience – and not only mine – suggests that the whole procedure is very well perceived by the decision maker. It's very easy to discuss with a wide range of people.

RAIFFA: I would be interested to see a comparison of this methodology with the methodology that I am used to, multiattribute utility analysis. It would be nice to see some concrete examples. It seems that this procedure may be well suited to screening the alternatives to identify the viable ones; then a more quantitative approach may be used for examining the remaining alternatives.

3 A Research Project on Multicriterion Decision Making

J. Wallenius and S. Zionts

3.1 INTRODUCTION

In 1973 Wallenius and Zionts undertook a project on multicriterion decision making at the European Institute for Advanced Studies in Management. The reasons for beginning such a project were many. Wallenius had recently completed a study in which he tested three decision-making methods using a sample of university students and middle-level managers. He found the results disappointing: for a rather well-defined and well-structured problem a somewhat naive method (Wallenius' unstructured approach) seemed to work as well as or better than two current state-of-the-art methods (Geoffrion, 1970; Benayoun *et al.*, 1971). Zionts had earlier developed a normative approach together with Contini (Contini and Zionts, 1968) that contained rather strong assumptions and produced some interesting results. Zionts then attempted to apply this approach in several instances – the development of a model for allocating steel production (Zionts, 1967) and a possible solution to a labor–management problem of U.S. railroads – although neither exercise went beyond the formulation stage. There have been other methods proposed (for example, Aubin and Näslund, 1972; Belenson and Kapur, 1973; Dyer, 1972, 1973), and there have been numerous attempts at application (for example, Agarwal, 1973; Geoffrion *et al.*, 1972), although the methods have not been widely used in practice.

It was against this background that Wallenius and Zionts embarked on a joint project to develop a workable framework and method for solving multicriterion problems, a methodology that could be used by persons unfamiliar with mathematical methods and would be applicable to reasonably complex problems. The

The research described in this paper was begun when the authors were with the European Institute for Advanced Studies in Management, Brussels.

authors agreed to adopt a framework of constrained optimization with several objectives and one decision maker. Because linear programming methods are highly developed for solving large problems, a framework based on an additive utility function that had concave objectives on a convex set and linear approximations was chosen.

In this paper the authors present the background, method, extensions, and current status of their implementation effort.

3.2 THE METHOD¹

We assume that the decision maker can specify his objectives as concave functions to be maximized, but that he cannot explicitly specify his utility function. We further assume that the utility function is additive in the objectives, and we subsequently relax this assumption to a general concave utility function of objectives. The method is interactive in that the decision maker is presented with a sequence of efficient (undominated) solutions and for each solution is asked to indicate his reaction to a set of proposed feasible trade-offs. In other words, we ask him to respond "yes," "no," or "uncertain" to each trade-off proposed. The method converges in theory and seems to converge in practice as well.

To state this more formally, it is assumed that there are p objectives u_i that are explicitly known concave functions of the decision variables x_1, \dots, x_n (or x in vector notation). Without considering conflicts among objectives, the decision maker wishes to maximize each objective (without loss of generality). The overall utility function U is assumed to be a linear function (and, more generally, a concave function) of the objective function variables $u_i, i = 1, \dots, p$, but the precise weights in such a function are not known explicitly. Because we rely heavily on piecewise linearization in the method that we propose, it is important to realize that certain additional assumptions, though not necessary, will greatly simplify the linearization process. Thus, if the objectives u_i are additively separable functions of the decision variables x_1, \dots, x_n , the linearization may be accomplished separately for each variable $x_j (j = 1, \dots, n)$. We emphasize that such an assumption is a convenience in practice, although it is not required in theory.

The case in which the implicit utility function is some general concave function of objectives will be treated as a modification of the basic method in which an additive utility function is assumed. In this case, the optimal solution will be in a neighborhood (ideally a small one) that can be expressed as the convex combinations of a known subset of solutions. Depending on the situation, further analysis may or may not be desirable to locate a solution within the neighborhood.

¹ This section is based on the discussion presented in Zionts and Wallenius (1976).

3.2.1 SOME NOTATION

Let the linearized approximation to the constraint set be

$$Ax = b \quad x \geq 0, \quad (3.1)$$

where A and b are, respectively, a matrix and vector of appropriate order, and x is a vector of decision variables of appropriate order. Further, assume that each objective function is of the form $u_i = f_i(x)$ ($i = 1, 2, \dots, p$). The equality constraints in Eq. (3.1) may be derived from inequality constraints to which slack variables have been added. We can approximate such a function as accurately as we wish by piecewise linearization, introducing the constraints

$$u_i \leq f_i^j x + g_i^j \quad j = 1, \dots, p(i), \quad (3.2)$$

where f_i^j is a row vector of appropriate order, g_i^j are constants, and u_i is the value of the objective function $f_i(x)$. (If u_i can be unrestricted in sign, some precautions must be taken to allow for that in the computational process.) If the functions $f_i(x)$ are, in addition, additively separable, a somewhat different set of constraints may be used. In either case, designate the entire set of constraints for all objective functions in matrix form as

$$Eu - Cx \leq g, \quad (3.3)$$

where g is a vector of the constants g_i^j . If each f is a linear function of x we will have $E = I$, an identity matrix, and C will be a matrix of all objective functions. If each f is not a linear function of x , E will be a matrix having for each row a unit vector (all elements except one 0 and the nonzero element, 1). However, there will be more than one unit element in each column corresponding to a u that is nonlinear in x .

We also assume certain absolute minimal levels of u as part of the problem constraint set: that is,

$$u \geq h. \quad (3.4)$$

Consider now the linearized convex set of Eqs. (3.1), (3.3), and (3.4) as the constraint set of the problem. Given the above preliminaries, we can present the method as a sequence of instructions, first noting that it is generally a good idea to scale the objective functions so that the nonzero coefficients of C are close to 1 in absolute value. Then we use the following sequence:

1. Generate an initial set of weights $\{\lambda_i \geq \epsilon\}$, with ϵ a sufficiently small positive constant. (We employ a constraint $\sum \lambda_i = 1$ for convenience, although it is not necessary in practice.)

2. Using a current set of weights $\{\lambda\}$, solve the linear programming problem whose constraints are Eqs. (3.1), (3.2), (3.3), and (3.4) and whose objective is to maximize λu . The optimal solution x will be an efficient or undominated solution in terms of the objective vector u . Then, let x^i , $i = 1, \dots, I$ be those extreme

points of the feasible region that are adjacent to this optimal solution. By means of a new linear programming optimization, check each x^i to see if there exists a feasible λ^i (feasible with respect to all known constraints on the λ^i from previous operations) such that $\lambda^i u(x^i) > \lambda^i u(x^*)$. (This particular approach is mentioned only for the sake of clarifying the idea; the method we use has been described in section 3.2.) If there are no such extreme points, stop. The marginal rates of substitution of objectives to an adjacent point comprise a trade-off offer; a question posing such an offer to the decision maker is called an efficient question.

3. Ask the decision maker to consider each efficient question with respect to the current solution. He should indicate "yes" (he accepts the trade-off proposed); "no" (he does not accept it); or "uncertain" (it is difficult to determine whether or not he would accept it).

4. Find, through an optimization, a set of weights $\{\lambda_i\} \geq \epsilon$ consistent with all previous questions (as before, with $\sum \lambda_i = 1$). Go to step 2.

To elaborate on the above, for each nonbasic variable x_j let w_{ij} represent the *increase* in objective function u_i due to some specified increase in x_j . Then for each variable of a subset of efficient variables the decision maker is told: "Here is a trade-off. Are you willing to accept an increase in objective function u_1 of w_{1j} , an increase in objective function u_2 of w_{2j} , . . . , and an increase in objective function u_p of w_{pj} ? Respond 'yes,' 'no,' or 'uncertain' to the desirability of the trade-off." (There will be at least one positive w_{ij} and at least one negative w_{ij} for each efficient variable.)

Using the decision maker's responses, we construct constraints to restrict the choice of the weights λ to be used in finding a new efficient solution. For each "yes" response, we construct an inequality such as the following (where ϵ is a sufficiently small positive number):

$$\sum_{i=1}^p w_{ij} \lambda_i \geq \epsilon. \quad (3.5)$$

For each "no" response, we construct an inequality of the form

$$\sum_{i=1}^p w_{ij} \lambda_i \leq -\epsilon. \quad (3.6)$$

Earlier we used the "uncertain" responses to attempt to satisfy (as an objective) the constraint

$$\sum_{i=1}^p w_{ij} \lambda_i = 0, \quad (3.7)$$

but currently we do not use these responses. To identify a set of weights consistent with previous responses we use linear programming to find a feasible solution to the constraints, Eqs. (3.5) and (3.6), and also $\lambda_i \geq \epsilon$ and $\sum \lambda_i = 1$.

Thus, the underlying problem would be an ordinary linear programming problem, if the decision maker's λ were known. Initially there are no restrictions on the vector λ , but constraints are added successively to restrict the choice of weights. Once we find the optimal solution for a given set of weights, we identify the efficient trade-off questions. The method for doing this is based on linear programming (section 3.2). The trade-offs are given by the shadow prices for each of the objectives for any one nonbasic variable, and the efficient questions are derived from a subset of the nonbasic variables.

A proof of convergence may be built on the finiteness of the number of efficient extreme-point solutions. Each question session, except possibly the last, excludes at least one efficient extreme-point solution. Thus, the procedure is finite. This finiteness may not seem very appealing, however, because of the large number of efficient extreme points that may exist. In practice, the convergence experience for sizable problems has been good. Although a utility increase between successive applications of step 2 is not assured, and does not always occur, it has occurred almost every time in practice (except for a specifically contrived example).

3.2.2 THE METHOD FOR ARBITRARY CONCAVE UTILITY FUNCTIONS OF OBJECTIVES

The method can be extended to solve a more general class of problems having a general concave utility function of objectives that are, in turn, linear functions of the decision variables. In such a case, the method has a solution within some (ideally small) neighborhood of an optimum. (If desired, further optimization, which is not a part of the method, may be undertaken to find an optimum.) The extension is based on local linearization of the utility function and periodic removal of previous responses. We first solve the original linear programming problem with an arbitrary set of multipliers and find an efficient solution. Then we generate a set of efficient questions and ask the decision maker to respond "yes," "no," or "uncertain" to the questions. (We may alternatively compute the efficient extreme points that are adjacent in the objective-function space. Fandel and Wilhelm (1975) interpreted our method in this way; it has an advantage for a subsequent phase of the algorithm.)

Using these responses, we generate a new set of multipliers and find a new efficient solution. Up to this point the method is exactly the same as before. We then ask if the new solution is preferred to the old. If so, all previous responses are removed, a new set of efficient questions is generated, and the procedure is continued from the new solution. If the old solution is preferred, we continue the procedure from an efficient solution adjacent to the old solution in the objective-function space corresponding to a favorable ("yes") response. If there is no such solution (the condition for termination), the optimal solution to the problem lies in the neighborhood of the old solution defined as the convex hull of the old

solution and all efficient solutions adjacent to the old solution in the objective-function space. (There are numerous options for implementing the procedure; we have suggested only one. The selection of the variation that works well in practice must await implementation and testing).

As mentioned above, further optimization to find the optimum may then be used if desired, but if the solutions are relatively "close" in terms of the objective-function values, it will probably be worthwhile to terminate with the solution obtained through use of the altered method. We have not tested this change in practice, but its validity follows from the concavity of the implicit utility function and the linearity of the constraint set.

3.2.3 AN EXAMPLE

We now present a small example of the method in some detail. Consider the following set of constraints:

$$\begin{aligned} 2x_1 + x_2 + 4x_3 + 3x_4 &\leq 60 && \text{(slack } x_5), \\ 3x_1 + 4x_2 + x_3 + 2x_4 &\leq 60 && \text{(slack } x_6), \\ x_1, x_2, x_3, x_4 &\geq 0, \end{aligned}$$

and the following objective functions, all to be maximized:

$$\begin{aligned} u_1 &= 3x_1 + x_2 + 2x_3 + x_4, \\ u_2 &= x_1 - x_2 + 2x_3 + 4x_4, \\ u_3 &= -x_1 + 5x_2 + x_3 + 2x_4. \end{aligned}$$

For the example, we assume that the (implicit) utility function is $0.58u_1 + 0.21u_2 + 0.21u_3$, but we will use the knowledge of this function only in answering the yes or no questions. Initially, we arbitrarily choose $\lambda_1 = \lambda_2 = \lambda_3 = 0.333$ and maximize $0.333u_1 + 0.333u_2 + 0.333u_3$ subject to the problem constraints. The optimal solution is $u_1 = 24, u_2 = u_3 = 66$. The nonbasic variables are x_1, x_3, x_5 , and x_6 . The increases for each of the three objective functions corresponding to a unit increment in each of these variables are for x_1 : $+2, -0.5, -4.5$; for x_3 : $+1, -4.5, +0.5$; for x_5 : $-0.2, -1.8, +0.2$; and for x_6 : $-0.2, +0.7, -1.3$.

By way of explanation, problem (3.9) (for finding the set of efficient nonbasic variables) for x_1 is

$$\begin{aligned} &\text{Maximize } 2\lambda_1 - 0.5\lambda_2 - 4.5\lambda_3 \\ &\text{subject to:} \quad \lambda_1 - 4.5\lambda_2 + 0.5\lambda_3 \leq 0, \\ &\quad \quad \quad -0.2\lambda_1 - 1.8\lambda_2 + 0.2\lambda_3 \leq 0, \\ &\quad \quad \quad -0.2\lambda_1 + 0.7\lambda_2 - 1.3\lambda_3 \leq 0, \\ &\quad \quad \quad \lambda_1, \lambda_2, \lambda_3 \geq 0. \end{aligned}$$

Since the maximum is positive (infinite), the trade-offs offered by x_1 are efficient. Similarly, variables x_3 and x_6 offer efficient trade-offs, whereas x_5 does not offer an efficient set of trade-offs. We then ask the decision maker whether he likes or dislikes each set of efficient trade-offs. Thus, for x_1 , is he willing to accept an increase of 2 units of u_1 in return for a decrease of 0.5 units of u_2 and a decrease of 4.5 units of u_3 ? To simulate a response we compute an evaluation: $0.58(2) + 0.21(-.5) + 0.21(-9.5) > 0$. Thus, there is a net *increase* in the decision maker's utility; he should like that set of trade-offs. Similarly, he does not like the trade-offs posed by x_3 and x_6 . We thereby generate the inequalities of the form (3.5) and (3.6) and find a feasible solution to the set of constraints (arbitrarily setting $\epsilon = 0.001$)

$$\begin{aligned} 2\lambda_1 - 0.5\lambda_2 - 4.5\lambda_3 &\geq 0.001, \\ \lambda_1 - 4.5\lambda_2 + 0.5\lambda_3 &\leq -0.001, \\ -0.2\lambda_1 + 0.7\lambda_2 - 1.3\lambda_3 &\leq -0.001, \\ \lambda_1 + \lambda_2 + \lambda_3 &= 1, \lambda_1, \lambda_2, \lambda_3 \geq 0.001. \end{aligned}$$

A basic feasible solution is $\lambda_1 = 0.777$, $\lambda_2 = 0.222$, $\lambda_3 = 0.001$. Using these multipliers to generate a new utility function, which we maximize over the two constraints of the original problem, we find the optimum to be $u_1 = 66$, $u_2 = 30$, $u_3 = -12$. Corresponding to that solution there are four nonbasic variables: x_2 , x_4 , x_5 , and x_6 . By solving problem (3.9) for these variables using the constraints derived from the answers to the earlier trade-offs, we find that the only efficient trade-offs are those associated with x_4 . Accordingly, the set of trade-offs associated with x_4 is put to the decision maker for his evaluation. Because the set is attractive, the trade-offs are used to generate the constraint $-1.5\lambda_1 + 2.5\lambda_2 + 2\lambda_3 \geq 0.001$, which is added to the constraint set above. A feasible solution is $\lambda_1 = 0.594$, $\lambda_2 = 0.160$, $\lambda_3 = 0.246$. Using these multipliers to generate a utility function we find the optimal solution to the original problem for this function to be $u_1 = 48$, $u_2 = 60$, $u_3 = 12$. Appending the generated constraints in problem (3.9), we find that none of the nonbasic variables at this solution is efficient; hence the solution is optimal and the multipliers $\lambda_1 = 0.594$, $\lambda_2 = 0.160$, $\lambda_3 = 0.246$ are equivalent (for this problem) to our unknown multipliers.

3.3 EXTENSIONS TO THE MULTICRITERION DECISION-MAKING METHOD

In addition to refining the multicriterion method, we have developed three extensions. The first was described in section 3.2.2, where we extended the method to a general concave utility function of objectives. In this section we present two other extensions: a method for solving integer programming problems and a method for determining the efficient subset of a set of vectors.

3.3.1 INTEGER LINEAR PROGRAMMING WITH MULTIPLE OBJECTIVES¹

Using the framework presented in section 3.2, it seems that a natural extension of that method would make it possible to solve integer programming problems by solving the continuous multicriterion problem and, using the multipliers thus obtained, solving the associated linear integer programming problem. Unfortunately, however, that extension does not necessarily work. The following example is an illustration. Given the constraints

$$x_1 + \frac{1}{3}x_2 \leq 3\frac{1}{8}$$

$$\frac{1}{3}x_1 + x_2 \leq 3\frac{1}{8}$$

$$x_1, x_2 \geq 0,$$

with objectives $u_1 = x_1$ and $u_2 = x_2$ and multipliers λ_1 and λ_2 (>0) that satisfy the following relationships

$$\lambda_1 > \frac{1}{3}\lambda_2$$

$$\lambda_1 < 3\lambda_2,$$

then the continuous solution $x_1 = 2.34$, $x_2 = 2.34$ is optimal. However, even for this simple problem there are three optimal integer solutions corresponding to the same continuous optimum, depending on the true weights:

If $\lambda_1 > 2\lambda_2$, then $x_1 = 3$, $x_2 = 0$ is optimal.

If $2\lambda_2 > \lambda_1 > 0.5\lambda_2$, then $x_1 = x_2 = 2$ is optimal.

If $\lambda_1 < 0.5\lambda_2$, then $x_1 = 0$, $x_2 = 3$ is optimal.

The example could be readily made more complicated, but it serves to show that further precision is required in the specification of the multipliers.

The difficulty is that additional questions must be asked to specify the multipliers more precisely. Assuming that the utility function is additive, if the multipliers were known exactly, the problem would be an ordinary integer programming problem whose objective is simply to maximize λu .

There are numerous possible ways of further specifying the weights; we present two of them, both as yet untested.

The first is a dual cutting-plane approach. It is a logical extension of any dual cutting-plane method with respect to multicriterion decision making. Let k be a nonnegative integer, a choice variable that may be sufficiently large to be effectively infinite. The procedure is the following:

1. Find the continuous multicriterion optimum and set i to 0. Use the associated weights to generate a composite objective function.

2. Adjoin a cut, increase i by one unit, and optimize using the present composite objective function. Denote the result as the incumbent solution.

¹ Further details are provided in Zionts (1975).

3. If this incumbent solution is an integer, go to step 4. Otherwise, if i is not equal to k , go to step 2. If i is equal to k , go to step 5.

4. Set i to zero; generate efficient questions for the current solution that are consistent with previous responses. If the decision maker finds none of the trade-offs attractive (or if there are no efficient trade-offs), stop; the optimal solution has been found. Otherwise, use the responses to find a new composite objective function and perform the iterations necessary to achieve a linear programming optimum. Designate the associated solution as the incumbent solution, and go to step 3.

5. Set i to zero; generate efficient questions for the current solution that are consistent with previous responses. Use the decision maker's responses to generate a new composite objective function and perform the iterations (possibly none) necessary to achieve a linear programming optimum. Designate the associated solution as the incumbent solution, and go to step 3.

The validity of this method can be shown as follows. Every time an integer solution is found (and as long as k is not infinite, more often), questions are generated and the multipliers may be altered by the procedure. Every time step 4 is utilized, the optimality of an efficient integer solution (an efficient extreme point of the convex hull of all feasible integer solutions) is confirmed or denied. If it is confirmed, the optimality has been demonstrated; if it is denied, one extreme point has been eliminated from consideration. So long as the solution space is closed and bounded, the number of extreme points is finite. Therefore the procedure is finite.

The efficacy of choosing k to be finite is not clear, nor is the efficacy of the method known. How well this scheme works depends on the power of the cut method employed. Dual cut methods are not currently used much because they do not work well in practice; thus it is unlikely that a multicriterion scheme based on a dual cut will work well. We therefore turn our attention to branch and bound algorithms. The essential theorem of Zionts (1975) is the basis for such an algorithm:

THEOREM 1 A solution may be terminated without further branching, provided two conditions hold: The decision maker prefers a feasible integer solution to it, and all efficient trade-off questions associated with the solution are viewed negatively or with indifference.

Proof As shown by the decision maker's preference, the known integer solution has a greater objective-function value than the solution in question. Further, since no continuous neighbor is preferred to the solution, any further restricted solution will have a lower objective function than the solution in question and, therefore, than the integer solution.

The question of preference is first checked by comparing the preference relationship with previously expressed preferences (derived from responses) to see whether

the preferences can be deduced. If they can be deduced, the preference is known; if not, a question is posed to the decision maker, and the responses further restrict the multiplier space. Whenever a new set of multipliers is found, it is to be substituted for the old set. An algorithm and an example should help to illustrate the above presentation.

1. Use the continuous multicriterion method described in section 3.2 to solve the continuous problem and obtain a set of weights that yields a linear programming problem for which the continuous optimum is the optimal multicriterion solution. Place that solution in the list of partial solutions.

2. Choose the partial solution having the maximum value of the current objective function. (Other criteria may also be used.) If the list is empty, stop; the best integer solution is optimal. (If none is found, there is no feasible integer solution.)

3. For the partial solution, choose an integer variable whose solution value is fractional. Solve two linear programming problems, one with the upper bound of that variable fixed at the next lower integer, the other with the lower bound of that variable fixed at the next higher integer. For each solution perform the following tests in the given order:

a. If there is no feasible solution, discard the solution.

b. Test the solution against the best integer solution using previously generated constraints and the theorem. If the results are not decisive, pose questions to the decision maker. Discard the solution if it is ruled out by the theorem.

c. If the solution is integral and preferred to the best integer solution, replace the best integer solution by it; if it is not, add the solution to the list of partial solutions.

4. Either zero, one, or two solutions will be added to the list. If none is added, go to step 2. If one is added, remove that solution from the list and go to step 3. If two are added, choose the preferred solution; remove it from the list; go to step 3. To find the preferred solution, first check the two solutions against previously generated constraints to see if the preference is implied. If not, ask the decision maker.

Further improvements based on other branch-and-bound integer algorithms may also be used.

To determine whether a preference is implied from earlier responses, a very small linear programming problem must be solved using the constraints based on all earlier responses of the decision maker. To illustrate, we use the same example presented earlier in this section. We assume that the true weights are $\lambda_1 = 0.7$, $\lambda_2 = 0.3$, but that the weights chosen at the continuous optimum are $\lambda_1 = 0.3$, $\lambda_2 = 0.7$. The tree of solutions is given in Figure 3.1. The circled number in each block indicates the order in which the solutions are found.

The following display shows the optimal continuous solution, where x_3 and x_4 are the slack variables. (The identity matrix has been omitted.)

		x_3	x_4
x_1	2.34	1.125	-0.375
x_2	2.34	-0.375	1.125
u_1	2.34	1.125	-0.375
u_2	2.34	-0.375	1.125

Two questions are found in the last two rows of the display: Are you willing to decrease u_1 by 1.125 units to increase u_2 by 0.375 units? A simulated response is obtained by using the true weights. Here we compute $-1.125(0.7) + 0.375(0.3)$. Since the sum is negative, the response is "no." Are you willing to increase u_1 by 0.375 units by having u_2 decrease by 1.125 units? (Response: "no.") The negative responses confirm the optimality of the solution of the display. The constraints are then

$$\lambda_1 > \frac{1}{3}\lambda_2$$

$$\lambda_1 < 3\lambda_2$$

By using $\lambda_1 + \lambda_2 = 1$, and eliminating λ_2 , we have

$$0.25 < \lambda_1 < 0.75.$$

As indicated above, we use $\lambda_1 = 0.3$ (noting that the true value is $\lambda_1 = 0.7$). Solving the two linear programming problems by branching on x_1 from the noninteger optimum, we have solutions 2 and 3. The preferred solution is not obvious; thus, we illustrate the test. Solution 3 has a utility of $3\lambda_1 + 0.375\lambda_2$. Solution 2 has a utility of $2\lambda_1 + 2.458\lambda_2$. The utility of solution 3 less that of solution 2 is $\lambda_1 - 2.0833\lambda_2$.

When we use $\lambda_2 = 1 - \lambda_1$, we have $3.0833\lambda_1 - 2.0833$.

Because $0.25 < \lambda_1 < 0.75$, the expression can be either positive or negative; hence a question is asked. The decision maker prefers solution 3, and we have a new constraint:

$$3.0833\lambda_1 - 2.0833 > 0, \quad \text{or} \quad \lambda_1 > 0.675.$$

Thus, we now have $0.675 < \lambda_1 < 0.75$; we choose $\lambda_1 = 0.71$. We then branch on solution 3 to find solutions 4 and 5 (the latter infeasible) and then branch on solution 4 to find solutions 6 and 7 (the latter infeasible). Because solution 6 is an integer, we compare it with the only active solution on the list, solution 2. The answer is not implied, so we ask the decision maker which solution he prefers. He prefers solution 6; then the constraint

$$\lambda_1 - 2.4583\lambda_2 < 0 \quad \text{or} \quad \lambda_1 < 0.711$$

is added. This results in $0.675 < \lambda_1 < 0.711$, and we choose $\lambda_1 = 0.69$. Branching on solution 2, we obtain solutions 8 and 9, both of which are implied to be less

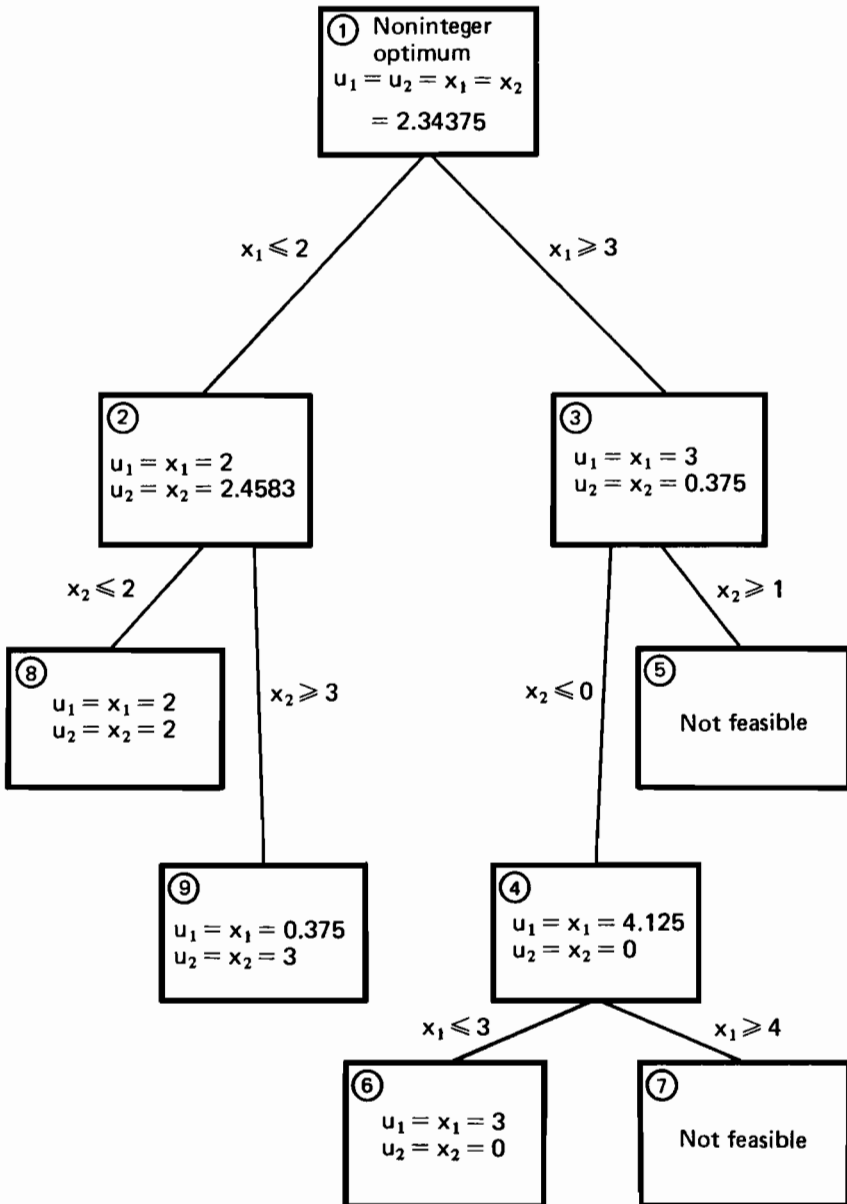

FIGURE 3.1 Branch-and-bound solution of the example.

attractive than the best-known integer solution. Since the decision maker views trade-offs at solutions 8 and 9 negatively, both solutions can be discarded. Since there are no solutions remaining on the list, solution 6 is optimal.

Neither of these proposals has yet been tested; we can only speculate about the performance. Clearly the branch-and-bound approach appears to be promising. In addition, in view of the success of branch-and-bound procedures in solving certain integer programming problems, unless the number of practical solutions that must be examined is much larger than what is currently encountered, the method appears quite feasible. Further statements must await empirical testing.

3.3.2 IDENTIFYING EFFICIENT VECTORS¹

As part of the basic method presented in section 3.2, we defined the efficient questions to solve the problem of identifying the efficient trade-off vector. A naive method for solving the problem was to solve a number of linear programming problems, one for each vector considered, but as we showed in Zions and Wallenius (1975), this procedure can be greatly streamlined and is currently an important subprogram of our method. To give an idea of how the methods work we provide some background on the problem of finding efficient trade-off vectors and present a statement of the method as well as some results.

An efficient trade-off vector must have at least one negative component. Further, the vector indexed k is not efficient if there exists a set of multipliers μ_j satisfying

$$\sum_{j \neq k} \mu_j w_{ij} \geq w_{ik} \quad i = 1, \dots, P$$

$$\mu_j \geq 0. \quad (3.8)$$

By attributing a null minimizing objective function and writing a dual linear programming problem, we have

$$\begin{aligned} &\text{Maximize} && \sum_{i=1}^P w_{ik} \lambda_i \\ &\text{subject to} && \sum_{i=1}^P w_{ij} \lambda_i \leq 0 \quad j \neq k \\ &&& \lambda_i \geq 0. \end{aligned} \quad (3.9)$$

If the maximum is positive (it will be infinite), the vector indexed k is an efficient trade-off vector.

The method is to begin to solve the linear programming problem given in (3.9). We denote the slack variables as v_m and at each iteration use tests based on the

¹This section is based on Zions and Wallenius (1975).

following theorems (proofs of which are given in Zions and Wallenius, 1975) and their corollaries for all vectors. Whenever the status of the vector corresponding to the objective function becomes known, we change to an objective function that corresponds to a vector whose status is not known.

THEOREM 2 Suppose that variable v_m is nonbasic. If in every row in which the variable has a negative coefficient the basic variable is nonzero, vector m is efficient.

Remarks In all iterations of interest all basic variables will have zero values. Thus, the theorem can be simplified to the following: if variable v_m is nonbasic and has only nonnegative elements in the column of the tableau, vector m is efficient.

THEOREM 3 If variable v_n is basic for a basic feasible solution, and all coefficients in the associated row of the simplex tableau (excluding that of v_n) are nonpositive, the vector n is inefficient.

Remarks We may also observe a row having exactly one negative coefficient with a value of b_i of zero. In such a case, if the variable having the negative coefficient is a variable v_n , then n is not an efficient vector. Whenever a variable v_n corresponding to an inefficient vector is basic, the associated constraint may be eliminated.

We use formulation (3.9) with a tableau that omits the identity matrix. Each v variable has an initial status of unknown; each λ variable, an initial status of known. The status of a row is that of its basic variable; the status of a column, that of its (nonbasic) variable. By "known," we also mean efficient and inefficient. Thus,

1. For any row with status unknown, with all coefficients nonpositive, change the status of the row to inefficient and delete the row. Go to step 2.

2. For any row with precisely one coefficient that is negative, change the status of the column (if it is unknown) corresponding to the negative coefficient to inefficient. Go to step 3.

3. For any column with status unknown that has all coefficients nonnegative, change the status of the column to efficient. Go to step 4.

4. For any column having precisely one coefficient that is positive, change the status (if unknown) of the row corresponding to the positive coefficient to efficient. Go to step 5.

5. If the first row has a status of efficient or known, go to step 6. If not, choose a nonbasic variable with a positive coefficient in the first row and perform a simplex iteration so that it is basic (employing perturbation methods if necessary to prevent cycling). If the entering variable is inefficient, delete the row in which it appears. Go to step 1.

6. If there are any other rows having unknown status, exchange one of these rows with the first, and go to step 5; if not, go to step 7.

7. If there are no columns with unknown status, stop; all vectors have been classified. If there are any columns with unknown status, perform an iteration to make one of them basic in the first row (exchanging rows if necessary), and then go to step 1.

Thus far we have not developed measures of performance of the efficiency method per se but the method as stated above is an integral part of our multicriterion method and seems to be performing adequately. Variations of the method may be used to solve other problems (see Zionts and Wallenius, 1975).

Extensions of this method have been discussed, although not pursued. Professor H. Thiriez of the Centre d'Enseignement Supérieur des Affaires, Jouy-en-Josas, France, has suggested use of the method by several decision makers in a Delphi-like setting. Various aspects of this idea have been considered in informal discussions.

3.4 TESTING AND APPLICATION

Although much work has been done in developing algorithms for solving multicriterion problems of constrained optimization, there is little evidence of application of such methods in practice. Because much of our work was motivated by the need for a workable framework, the performance and use of the method in practice is of great importance. In developing the method, we solved a number of small and medium-sized test problems in which we assumed that the utility functions were known, solely for the purpose of simulating responses to the questions raised. Although our testing was not exhaustive, the performance was sufficiently good that we felt the next question was to explore the applicability of the method in practice. We were concerned with such questions as how well the method worked, whether managers would be consistent when using it, and whether they would find the method useful. We searched for an appropriate practical problem and tried to find a firm that was already using linear programming and was willing to try our method.

3.4.1 AN ATTEMPT AT IMPLEMENTATION

After much searching, we found a company willing to participate in our study. We subsequently learned, however, that the firm was not using linear programming to solve the multicriterion problem proposed for the study but instead to solve another problem, a single-objective short-term scheduling problem. Thus, to set up the test we had to take part in developing a model for the company. To avoid confounding the evaluation of the method with that of the model, we emphasized to the managers that we wanted to make a distinction between the method and the model, insofar as possible.

The company with which we worked was S. A. Cockerill, a large steel corporation in Seraing, Belgium. Our initial contact was a manager in the Corporate Planning Department who is responsible for making various special long-range planning studies. Although he uses certain packaged computer routines, he does not consider himself a specialist in computers or operations research. Our early work on the model was almost entirely in cooperation with this manager, but his superior, a more senior manager, later became involved.

During the first sessions we discussed the problem, the system currently used to solve the problem, our method, and our objectives in the study. The problem was important to the company, and substantial resources were used in trying to solve it. A simulation approach was used whereby the effects of alternative decision choices were computed and extrapolated. Management was not pleased with the performance because of the results obtained with the trial-and-error approach. The strategy that we agreed to follow was to start by solving a simplified version of the problem and later expand and refine the problem representation. The point of departure for us was a simplified multiple-objective linear programming example developed by one of the managers for demonstration purposes. However, because there was no conflict among the objective functions of the problem, the objectives had to be reconsidered and the example improved. We then demonstrated the use of the method to the managers by simulating responses to questions according to an assumed utility function.

Within 2 months, during which we worked closely with one of the managers, we developed two models – a small, simplified model and a larger, more realistic problem representation – and then planned the objective functions to be included in the study. The problem was to make some long-range capital investment decisions regarding steel production facilities; these decisions involved multiple criteria. A simplified representation of the steel plant was constructed jointly with the managers. Various processing units were represented, as were scrap losses, and other factors. The financial aspects of the model are represented in considerable detail (separate short-term and long-term financing, depreciation, and taxes), whereas marketing aspects are less precisely represented. In the simulation approach numerous measures of effectiveness were used. Together with the managers, we established four objectives as key criteria in the evaluation of corporate planning decisions:

Maximize cumulative cash flow at the end of the horizon.

Minimize long-term loans taken during the horizon.

Maximize net worth at the end of the horizon.

Minimize short-term loans (slightly different formulations were used in the two models).

We now briefly consider the nature of the conflict among these objectives. Maximizing cash flow or net worth is in direct conflict with minimizing long-term

or short-term debt. We can further regard the first two objectives as measures of return and the last two as measures of risk. Cash flow and net worth differ because of depreciation, and long-term and short-term debt have different associated effects.

As mentioned earlier, two versions of the model were formulated: a small two-period model in which each period represents 1 year, and a larger four-period 10-year model in which successive periods represent 1, 2, 3, and 4 years. The smaller model has 21 equations and 47 variables; the larger model, 143 equations and 248 variables. (The number of variables includes slack but not artificial variables. Upper bound constraints and associated slack variables are not counted.) Data for the models came from existing information as well as projections available to the managers. More detailed information regarding the models may be found in Wallenius (1975b).

The computer program used for the tests was implemented on the IBM 370/158 computer at S. A. Cockerill. The MPSX (Mathematical Programming System Extended) program was used with FORTRAN subroutines to provide the linkage, to determine the questions to be asked of the decision maker, and to accept the responses. Because of the computer configuration at S. A. Cockerill, all the tests had to be made in a batch processing mode. Any results, therefore, should be enhanced when an interactive processing mode is used. In addition, because of the time pressures during the programming phases, no attempt was made to generate an efficient program. The emphasis was on simplifying the programming task. Thus, there were many parts of the program that could have been improved. For example, each time a composite objective function was used to generate an efficient solution consistent with previous responses, no use was made of previous problem solutions. Although many such improvements should be considered and made in using the method for regular problem solving, the current program is capable of solving reasonably large problems.

A brief discussion of the test results seems appropriate here. We first solved the models using simulated responses based on an assumed utility function. We then solved the models interactively by asking the managers individually to answer the questions.

We began to solve the simplified model by arbitrarily maximizing a linear utility function consisting of all objective functions equally weighted (after accounting for the different scales of measurement). We obtained two questions at the starting solution, and used the knowledge of an assumed utility function in answering the questions posed. We then found a set of consistent multipliers and solved the original problem using these multipliers. This time there were three questions to be asked. Using the multipliers implied by the answers to all five questions, the optimal solution to the problem was generated.

The same starting solution and the associated set of questions were used with the actual responses of managers. Both managers found the first set of trade-offs attractive. At the second iteration one manager gave two "yes" and one "no"

response to the questions; the other gave one "yes" and two "no" responses. At the third iteration only one question was asked. The response of both managers was "no," and the use of the method was terminated after three sessions and six questions. Using the small model, both managers were consistent in their responses (although they were not in agreement with each other) and feasible multipliers for the objective functions could be found. With each successive set of multipliers, the associated solutions were preferred to those that had been used previously, both for the simulated responses and for the actual responses by the managers. As demonstrated by Zionts and Wallenius (1976), this does not always occur.

After completing the runs with the simplified model, we solved the large model twice by assuming different known linear utility functions to generate the responses. In the first trial 28 questions were asked; in the second, 24. Each trial consisted of six sessions to find the optimal solution. In addition, the implicit utility increased (although not necessarily strictly) from each solution to the next.

After the simulated runs were completed, one of the managers used the method on the large model. The first trial required 8 question sessions and 23 questions, and because of the batch mode of operation we changed the program somewhat. The current program is the same as that described here; more information about the change may be found in Wallenius and Zionts (1975). The second trial required 4 question sessions and 19 questions.

We now address the reactions of the managers to the method and to the models.

The linear programming models (both small and large) were rather hastily constructed and were criticized for lack of realism. Several suggestions were made for making the models more realistic, such as increasing the number of periods, adding consideration of human resources, and complicating debt arrangements and dividend policy. These and other improvements in the models will have to be the subject of future work.

Our initial experience with the method was favorable. The managers seemed to find satisfactory solutions using the method. The method was also sufficiently easy to use and to understand for persons unfamiliar with mathematical multicriterion decision methods. In more detailed discussions many interesting points were raised. The number of questions was not considered to be too large in any trial, but the first trial with the large model required too many sessions (8) to complete the runs within a day. (A time-sharing mode of operation would alleviate this problem.) The majority of the questions were easy to answer, and the few difficult questions were dealt with adequately by responses of "uncertain." The managers were consistent in their responses, and we were therefore able to find feasible multipliers for the objectives.

After completing the tests with the middle-level managers, we made a presentation of our work to a senior manager, a member of the Board of Directors. We simulated some of the early responses but did not have a chance to make a complete trial run using the computer. The reaction of the senior manager was favorable, but he expressed some concern for the program's inability to solve problems involving integer variables.

A few other observations may be of interest. When we undertook the project, it was regarded by the company largely as an academic exercise, and although the company was willing to participate, there was considerable reluctance on its part to commit time and resources. As the study progressed, however, the company regarded it more seriously, contributed more, and there was participation at higher levels of management.

3.4.2 CURRENT IMPLEMENTATION AND TESTING ACTIVITY

In the interests of implementation, we have made our program available to prospective users. We have sent listings to numerous companies and individuals. We have been working with some of them and have asked all of them to keep us informed of their work with the method. We shall now briefly describe the current activities of which we are aware.

In conjunction with us, Reinhilde Van de Vlaed of the University of Ghent and Wally Van Gamplaer of Sidmar (Siderugie Maritime S.A.), Ghent, are developing a general-purpose FORTRAN computer program implementing the method that is intended for any linear programming system. The intention is to have a well-documented program that can be used for application and other test purposes. It will be freely available as soon as it is completely tested. Sidmar then plans to use it in a short-term steel production planning problem; its objectives include profits and other measures of performance, including a measure of change in product mix. The model has already been run as a linear programming problem, using profits as the objective function with constraints on some of the other objectives.

Professor H. Muller plans to use the multicriterion method at the University of Ghent in the context of a management game. He intends to compare the performance of teams in the game as a function of their use of the multicriterion method.

N. V. Philips, of Eindhoven, the Netherlands, has used our program and has developed a strategic planning model for Philips. The model considers interactions among the various major divisions at Philips as well as with the markets. Objectives such as overall profits, growth rates, and share of the market are included. Some objectives that are considered to be subsidiary are incorporated via constraints, and the remainder as objectives. A preliminary test of the model has been made, and it is now being further tested at the management level.

3.5 CONCLUSION

We have not yet achieved our primary objective of having the method used in practice by managers; however, we have made significant progress in this direction. We are now concentrating on

- Publicizing our work and making our program widely available
- Assisting organizations in the implementation and use of the program
- Identifying and correcting any problems in the functioning of the method and the program
- Implementing the general concave-utility-function version of the method as well as the mixed-integer version.

Comments, questions, and suggestions regarding our work are most welcome.

REFERENCES

- Agarwal, S.K. 1973. Optimizing techniques for the interactive design of transportation networks under multiple objectives. Ph.D. dissertation, Northwestern University, Evanston, Illinois.
- Aubin, J.P., and B. Näslund. 1972. An exterior branching algorithm. Working Paper 72-42. European Institute for Advanced Studies in Management, Brussels.
- Belenson, S.M., and K.C. Kapur. 1973. An algorithm for solving multicriterion linear programming problems with examples. *Operational Research Quarterly*, Vol. 24, pp. 65-77.
- Benayoun, R., J. de Montgolfier, J. Teargny, and O. Larichev. 1971. Linear programming with multiple objective functions: STEP method (STEM). *Mathematical Programming*, Vol. 1, pp. 366-375.
- Contini, B., and S. Zionts. 1968. Restricted bargaining for organizations with multiple objectives. *Econometrica*, Vol. 16, pp. 397-414.
- Dyer, J.S. 1972. Interactive goal programming. *Management Science*, Vol. 19, pp. 62-70.
- Dyer, J.S. 1973. A time-sharing computer program for the solution of the multiple criteria problem. *Management Science*, Vol. 19, pp. 1379-1383.
- Fandel, G., and J. Wilhelm. 1975. Towards the theory of multiple criteria. Paper presented at the Conference on Multiple Criteria Decision Making, Jouy-en-Josas, France, May 21-23.
- Geoffrion, A.M. 1970. Vector maximal decomposition programming. Working Paper. University of California, Los Angeles. (Also presented at the 7th Mathematical Programming Symposium, The Hague, September 1970.)
- Geoffrion, A.M., J.S. Dyer, and A. Feinberg. 1972. An interactive approach for multicriterion optimization with an application to the operation of an academic department. *Management Science*, Vol. 19, pp. 357-368.
- Wallenius, J. 1975a. Comparative evaluation of some interactive approaches to multicriterion optimization. *Management Science*, Vol. 21, pp. 1387-1396.
- Wallenius, J. 1975b. Interactive multiple criteria decision methods: an investigation and an approach. Ph.D. dissertation, Helsinki School of Economics and Business Administration.
- Wallenius, J., and S. Zionts. 1975. Some tests of an interactive programming method for multicriterion optimization and an attempt at implementation. Working Paper 75-3. European Institute for Advanced Studies in Management, Brussels. [Also in *Multiple Criteria Decision Making* (H. Thiriez and S. Zionts, eds.). Proceedings of the Jouy-en-Josas Conference, May 1975. Springer-Verlag, Berlin, 1976.]
- Zionts, S. 1967. A bargaining model for allocating steel production. *CORSI Bulletin* (Operational Research Society of India), pp. 69-78.
- Zionts, S. 1975. Integer linear programming with multiple objectives. Working Paper 75-32. European Institute for Advanced Studies in Management, Brussels.

- Zionts, S., and J. Wallenius. 1975. On finding the subset of efficient vectors of an arbitrary set of vectors. Working Paper 75-4. European Institute for Advanced Studies in Management, Brussels.
- Zionts, S., and J. Wallenius. 1976. An interactive programming method for solving the multiple criteria problem. *Management Science*, Vol. 22, pp. 652-663.

DISCUSSION

LARICHEV: I would like to ask a question about convergence. Your decision maker may not be able to give consistent answers, especially at the beginning of the process, when he may confuse his aim of trying to maximize all his objectives. Have you had any practical experience with this?

ZIONTS: Yes. We worked with a manager in one corporation and though perhaps we were lucky, he gave a response of "uncertain" in cases that were difficult for him, and we ignored those. If it became apparent that there was some contradiction, we would have to go back and review his answers or adopt a different form of questioning.

EDWARDS: In the example with 143 equations and 248 variables, what sort of questions do you ask the decision maker? How much information concerning the positions of the 248 variables does the decision maker review?

ZIONTS: He sees only the values of the four objectives for each position. He can have more information if he needs it, although that implies that he has more than four objectives.

DYER: In problems where there are many objectives, isn't it going to be difficult for the decision maker to sort out his preferences? Isn't it likely that some of his responses may be inconsistent?

ZIONTS: We had planned that the number of objectives should be less than six, although, of course, any number may be used. In practice, I think some of the objectives could be handled as constraints. We recognize that the human ability to discriminate is not so precise. That is why we have the "uncertain" response and hope that any errors will fall into that class.

EDWARDS: Is there some way of varying only subsets of the objectives at a time and then aggregating them a different way, repeating the process and then deducing an overall position?

ZIONTS: I think so; that's a good point. However, such an idea may not work very well in the general concave utility case.

4 Use of Vector Optimization in Multiobjective Decision Making

M. Peschel and C. Riedel

4.1 OVERALL FORMULATION OF THE PROBLEM

4.1.1 INTRODUCTION: DECISION MAKING FOR INDUSTRIAL SYSTEMS

We assume that we are dealing with a system that has some control variables that occur freely within given boundaries. The effect of optimization is measured by one or more quality criteria, which are functions of the control variables. The determination of the relationship between the quality criteria and the control variables is the main task of modeling; this modeling precedes optimization and often has a great influence on the result.

There are many cases in which the objective of a system is determined not by one but by many objective criteria that depend on the same set of control variables. For example, the objective might be to achieve a maximal effect (quality-parameter, accuracy, profit, production) with a minimal effort (cost, material, labor, energy). In general, if we want to optimize a number of criteria simultaneously, contradictions will arise between different demands, and these can be resolved only through a compromise. The contradictions occur because the individual criteria assume optimal values at different points within the common control area.

Two different controls can have different types of relationship: (a) one control will be preferred to another because it leads to better values for all criteria, or (b) the two controls cannot be compared because some criteria lead to better values for the first control, while other criteria produce better values for the second.

If we represent all possible values of two criteria, designated as Q_1 and Q_2 , by points in a plane with a Cartesian system of coordinates, we see that the comparison of different control variables is equivalent to a comparison of the corresponding criterion vectors (Q_1, Q_2) having the semiorder of their components in vector-space. The semiorder is the natural one. A vector is preferred to another only if no criterion is worse in the first vector than in the second and if at least one criterion is strictly better. This procedure is known as *Pareto preference*.

We can find examples of this in industry: the design of an electrically powered vehicle, the development of positioning circuits for machine tools, and the adjustment of the free parameters of a controller in automatic control. In all such cases, we are interested in choosing one compromise point out of a set of all efficient points in the sense of Pareto preference. The choice of the compromise point depends on additional conditions, demands, and experience and, in addition, on the subjective considerations of the decision maker. This optimization task is referred to in different ways in the literature. We find the terms "Pareto optimization," "polyoptimization," and "vector optimization." We shall call this kind of research *vector optimization*.

We can assume that preferences for all criteria are monotonically increasing as

$$Q_i(x_1, x_2, \dots, x_n) \rightarrow \max; \quad i = 1, 2, \dots, k.$$

The control vectors $x = (x_1, x_2, \dots, x_n)$ are generally restricted to a control area X ; the criterion vectors $Q = (Q_1, Q_2, \dots, Q_k)$ range across a corresponding area Y in the criterion space.

We have a static problem of vector optimization if we seek a solution that is a time-independent vector x^* ; we speak of a dynamic problem of vector optimization if we seek a solution in the form of a time function $x^*(t)$.

For determining the Pareto set of all efficient points we have to compare only the same components of the criterion vector. The problem of scaling arises if we want to have a compromise weighting, where each objective is weighted in comparison with the others.

To obtain sufficient solutions it is generally necessary to apply procedures having a "dialogue" character, which allow the decision maker to use his intuitive feelings to develop, step by step, an increasingly improved understanding of the structure of a Pareto set.

After obtaining adequate information about the Pareto set, we can establish a compromise with the help of decision theory. Figure 4.1 illustrates the interactions among vector optimization, model building, and decision making. Vector optimization supplies the decision maker with more information about the interrelationships among the criteria so that he may infer better compromises and so that he is better able to deal with situations in which he must make decisions in the presence of stochastic influences.

4.1.2 MATHEMATICAL BACKGROUND OF VECTOR OPTIMIZATION

We assume that we have at our disposal a set X of allowed control vectors $x = (x_1, x_2, \dots, x_n)$ that are given through the constraints

$$X = \{x \in R^n \mid f_j(x) \leq 0, \quad j = 1, 2, \dots, m\}.$$

Through the correspondence

$$Q_i = Q_i(x) \quad i \in K = (1, 2, \dots, k),$$

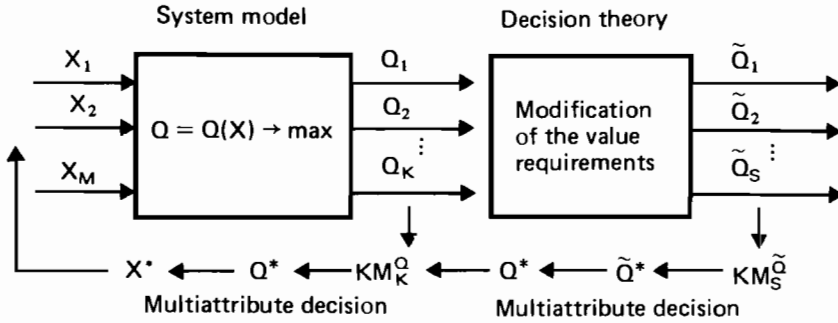

FIGURE 4.1 Schematic of the interactions among vector optimization, model building, and decision making.

the set X of the control space will be transformed to a set Y in the k -dimensional criterion space. Every element of the set Y ,

$$Y = \{Q(x) \in R^k \mid x \in X\},$$

is called an objective vector. We consider its components to be criteria of a vector-optimization task. Without any constraint we can state

$$Q = Q(x) \rightarrow \max.$$

For the Pareto preference relation we use the semiorder of vectors defined in the following way:

$$Q = (Q_1, Q_2, \dots, Q_k) \leq Q' = (Q'_1, Q'_2, \dots, Q'_k)$$

if $Q_i \leq Q'_i$ for $i = 1, 2, \dots, k$.

Q^* is a solution of the vector-optimization problem if it is a maximum element of the vector semiorder; in other words, there exists no point $Q \in Y$ with $Q_i^* \leq Q_i$ for all $i \in K$ and $Q_j^* < Q_j$ for at least one $j \in K$.

The set of all solutions of the vector-optimization task is the set of efficient points or the Pareto set P_k . For a set $S = (i_1, i_2, \dots, i_s)$ and $s < k$ let us determine for the criteria $Q_{i_1}, Q_{i_2}, \dots, Q_{i_s}$ the corresponding Pareto set P_s . Suppose $Q^* \in P_s \subset R^s$, and let us consider all the control vectors x^* that determine the point Q^* . Some control vectors may exist that lead to different values for the secondary criteria Q_j with $j \in \bar{S}$. Let us choose such control vectors x^* so that with fixed Q^* the secondary criteria Q_j will be vector maximized. We then obtain for Q^* a point $\tilde{Q}^* \in P_k$, and Q^* can in some sense be considered as a projection of \tilde{Q}^* .

The set of all \tilde{Q}^* constructed in this way is a subset of P_k ; thus, we designate it by P'_s : $P'_s \subset P_k$. All controls x that lead to efficient points in the criterion space are called efficient controls. Obviously, x^* is an efficient control if no control vector x exists with $Q(x) > Q(x^*)$.

For determination of the Pareto set P_k , two monotonic properties are of importance: criteria and control. For the first property, the control set X may be given. From all k criteria Q_i we choose $s < k$ and $Q_{i_1}, Q_{i_2}, \dots, Q_{i_s}$ and construct the corresponding Pareto set P_s . Taking into account the possibilities of the secondary criteria as described above, we develop a Pareto set $P'_s \subseteq P_k$. For $s = 1$ we obtain the optimal points of a single criterion; and for $s = 2$, the curves of bilateral compromises. For the second property, control, we vary only the components $x_{i_1}, x_{i_2}, \dots, x_{i_s}$; the other components x_j are fixed at the levels $x_j = x_j^*$. $P_k(X_s)$ comprise the Pareto set determined under the additional constraints. We obtain the following property:

$$P_k(X_s) \subseteq P_k(X_n).$$

The results can be improved only if we remove the constraints.

In some cases, the Pareto set $P_k(X_n)$ can be determined as an envelope of all constrained Pareto sets $P_k(X_{n-1})$; therefore, we speak of the *monotonic envelope property* of vector optimization. In the following discussion we shall assume that all criteria are functions with continuous derivatives in all the control variables.

Consider X as a connected domain having inner points and a boundary. X is transformed by the function $Q(x)$ into the domain Y in the criterion space. Y then has a boundary that possesses a tangential hyperplane at every point. The dimension of $P_k(X_n)$ satisfies

$$d(P_k(X_n)) \leq \min(n, k - 1).$$

Because the boundary of Y has this tangential hyperplane in every point, we obtain the following necessary condition (generally not sufficient) for the Pareto set P_k : At every point $Q^* \in P_k$ there exists one set of parameters λ_i with

$$\lambda_i(Q^*) \geq 0 \quad \text{and} \quad \sum_{i=1}^k \lambda_i(Q^*) dQ_i = 0.$$

That is, every efficient point Q^* is a stationary point of a certain "global" criterion Q , which is a linear combination of the Q_i ,

$$Q = \sum_{i=1}^n \lambda_i Q_i \quad \text{with } \lambda_i \geq 0.$$

Thus, the efficient points $Q^* \in P_k$ can be parameterized with the help of non-negative parameter vectors $\lambda = (\lambda_1, \lambda_2, \dots, \lambda_k)$. It is obvious that every point that is a global maximum of a linear combination $Q = \sum_{i=1}^k \lambda_i Q_i$ with $\lambda_i \geq 0$ belongs to the Pareto set P_k ; in general, the inverse statement does not hold.

It is shown in Focke (1973) that the following statement holds: if the control domain X is convex and all criteria are strictly concave, there exists an efficient control $x^* \in X$ if and only if x^* determines a global maximum of some linear combination

$$Q = \sum_{i=1}^k \lambda_i Q_i \quad \text{with } \lambda_i \geq 0.$$

Let us now deduce some conclusions from the stationary condition for the case of an unbounded control on $X = R^n$. Similar conclusions also can be derived for the case with constraints. Assuming that x is an interior point of X , we obtain from the stationary condition the following system of equations to determine the coefficients λ_i :

$$\frac{\partial Q}{\partial x_j} = \sum_{i=1}^k \lambda_i \frac{\partial Q_i}{\partial x_j} = 0 \quad j = 1, 2, \dots, n.$$

For the solution of these equations, the rank of the Jacobian

$$\frac{\partial Q_j}{\partial x_m} \quad (j = 1, 2, \dots, k; \quad m = 1, 2, \dots, n)$$

is of importance. For the rank ρ of the Jacobian $\rho \leq \min(n, k)$, two cases are of interest.

In the first case, $n \geq k$. For $\rho = k$ there exists a unique but trivial solution, $\lambda = 0$. The condition $\rho = k$ obviously can be fulfilled only at interior points of Y , because at boundary points there exists a tangential hyperplane. For $\rho < k$ there exist solutions $\lambda \neq 0$, and the Pareto set P_k can be parameterized by λ . The most important case is $\rho = k - 1$. In this case, we can interpret the rank-condition in the following way: $k - 1$ gradient vectors (for example, $\text{grad } Q_i, i = 1, 2, \dots, k - 1$) are linearly independent and $\text{grad } Q_k$ is a linear combination of them. Thus,

$$\text{grad } Q_k = \sum_{i=1}^{k-1} \mu_i \text{grad } Q_i.$$

This rank-condition can also be expressed as $k - 1$ sensitivity vectors ($\partial Q / \partial x_i, i = 1, 2, \dots, k - 1$), which are linearly independent, and all other sensitivity vectors ($\partial Q / \partial x_j, j = k, k + 1, \dots, n$) are linear combinations of them. Thus,

$$\frac{\partial Q}{\partial x_j} = \sum_{i=1}^{k-1} \mu_{ji} \frac{\partial Q}{\partial x_i}.$$

This last result can be interpreted as a step-by-step envelope-building process. For $j = k$ we form the envelope of all hyperplanes with $x_k = x_k^*$. For $j = k + 1$ we build an envelope of all the envelopes derived previously having the parameters $x_{k+1} = x_{k+1}^*$, and so on.

In the second case, $n \leq k - 1$, the mapping Y of X through $Q = Q(x)$ has no inner points in the k -dimensional criterion space. For $n = k - 1$ we obtain Y in the form of a $k - 1$ dimensional hyperplane of which P_k must be a part. As n decreases, the dimension of Y also decreases; thus, for $n = 1$, the mapping Y will be a curve in the k -dimensional criterion space of which P_k is a part.

The stationary condition expressed through the linear dependency of the gradients is

$$\text{grad} \left(Q_k - \sum_{i=1}^{k-1} \mu_i Q_i \right) = 0,$$

which is very similar to the Lagrangian optimization process, whereby $Q_i = Q_i^*$; $i = 1, 2, \dots, k-1$ is constant; and Q_k is maximized. For $n \geq k$, in general the ρ gradients ($\text{grad } Q_i, i = 1, 2, \dots, \rho$) are linearly independent and the other gradients ($\text{grad } Q_j, j = \rho + 1, \dots, k$) are linear combinations of them. Thus,

$$\text{grad } Q_j = \sum_{i=1}^{\rho} \mu_{ji} \text{grad } Q_i.$$

This stationary condition is also necessary for the points of the Pareto set P_k . It follows that the Pareto set can be described by one global criterion that expresses this linear dependency of the gradients. An example of this global criterion is the following procedure.

Suppose we determine for each linearly independent gradient ($\text{grad } Q_i, i = 1, 2, \dots, \rho$) so-called dual gradients ($\text{grad}^d Q_j$) using an algorithm described in Peschel (1975) that fulfill the conditions

$$(\text{grad } Q_i, \text{grad}^d Q_j) = \delta_{ij} = \begin{cases} 1 & \text{for } i = j \\ 0 & \text{for } i \neq j \end{cases}.$$

With the dual gradients we establish the following criterion:

$$Q = \sum_{j=\rho+1}^k \left[(\text{grad } Q_j, \text{grad } Q_j) - \sum_{i=1}^{\rho} (\text{grad } Q_i, \text{grad } Q_j) (\text{grad}^d Q_i, \text{grad } Q_j) \right].$$

It can be proved that $Q \geq 0$ with $Q = 0$ on the boundary of Y . If we exclude degeneracy, we can always assume that $\rho = k - 1$. In this case, we have for all μ_i in the linear combination

$$\text{grad } Q_k = \sum_{i=1}^{k-1} \mu_i \text{grad } Q_i$$

the condition $\mu_i \leq 0$ for the points of the boundary belonging to the Pareto set P_k .

Now the question arises: How should we proceed if the variation of x_i is constrained by inequalities $f_j(x) \leq 0, j = 1, 2, \dots, m$? If we know which inequalities exist, that is,

$$f_{j_1}(x) = 0, f_{j_2}(x) = 0, \dots, f_{j_r}(x) = 0,$$

obviously the number of free parameters reduces to $n' = n - r$. If we now obtain the case in which $n' \leq k - 1$, we have to treat the degeneracy of the dimension as described above; nevertheless, if $n' \geq k$, then for the one interesting case, $\rho = k - 1$, we can apply the results above in a slightly modified way. Accordingly,

we use our gradient conditions, for it is necessary to introduce only the active constraints into the definition of the gradients.

Thus, we reduce the gradient vectors to the components corresponding to x_i , $i = 1, 2, \dots, n'$ by redefining these components as follows:

$$\frac{\partial \tilde{Q}_i}{\partial x_t} = \frac{\partial Q_i}{\partial x_t} + \sum_{j=n'+1}^n \frac{\partial Q_i}{\partial x_j} \frac{\partial x_j}{\partial x_t},$$

where the derivatives $\partial x_j / \partial x_t$ can be determined from

$$\frac{\partial f_m}{\partial x_t} + \sum_{j=n'+1}^n \frac{\partial f_m}{\partial x_j} \frac{\partial x_j}{\partial x_t} = 0.$$

With these modified gradients, the linear-dependency condition,

$$\text{grad } \tilde{Q}_k = \sum_{j=1}^{k-1} \mu_j \text{grad } \tilde{Q}_j,$$

also holds.

The problem consists in recognizing which conditions will exist during the determination of the Pareto set P_k . If we use search procedures to determine particular points of P_k , we need accompanying tests for the existence of boundary conditions. We meet difficulties in the case of degeneracy when $n \leq k - 1 + r$. To illustrate how this method works, let us consider a very simple example:

$$Q_1 = x_1 + x_2 + x_3 \quad Q_2 = x_1 \cdot x_2 \cdot x_3,$$

with the constraints

$$x_i \geq 0 \quad \text{and} \quad k_1 x_1 + k_2 x_2 + k_3 x_3 \leq K.$$

First we consider the unbounded case, ignoring the constraints. We obtain the following gradient condition:

$$\text{grad } Q_1 = (1, 1, 1) = -\mu \text{grad } Q_2 = -\mu(x_2 x_3, x_1 x_3, x_2 x_3),$$

with the obvious solution $x_1 = x_2 = x_3$, with $\mu < 0$. In other words, this part of the boundary can be a Pareto set only when we want to minimize Q_1 and maximize Q_2 , or vice versa. This part of the boundary is characterized through the sign of the equality in the inequality $Q_2 \leq (Q_1/3)^3$. Let us now assume that the constraint $k_1 x_1 + k_2 x_2 + k_3 x_3 = K$ exists. Then we must work with the modified gradients

$$\text{grad } Q_1 = \left(\frac{1-k_1}{k_3}, \frac{1-k_2}{k_3} \right)$$

$$\text{grad } Q_2 = \left(\frac{x_2 x_3 - k_1 x_1 x_2}{k_3}, \frac{x_1 x_3 - k_2 x_1 x_2}{k_3} \right).$$

From the gradient condition $\text{grad } Q_1 = -\mu \text{grad } Q_2$ and the constraint, we obtain the following system of nonlinear equations for the determination of x_1, x_2, x_3 as

functions of μ , the parameter of the Pareto set:

$$\begin{aligned}(k_3 - k_1) &= \mu x_2(2x_1 k_1 + x_2 k_2 - K), \\(k_3 - k_2) &= \mu x_1(2x_2 k_2 + x_1 k_1 - K), \\k_3 x_3 &= K - k_1 x_1 - k_2 x_2.\end{aligned}$$

4.1.3 THE PREFERENCE PROBLEM

Every decision maker makes use of preferences. In a given situation he uses these preferences to make a rough approximation of what will be better and what will be worse. Let us first assume that we have a decision maker who makes his preferences according to the semiorder of vectors. We shall discuss this preference relation only for the case of two quality criteria, Q_1 and Q_2 . We obtain in the plane Q_1, Q_2 an optimal indifference curve, the Pareto curve, on which all the efficient points lie. Obviously, this is a monotonically decreasing curve.

Any set of monotonically decreasing functions that cover the domain Y without intersections is a possibility for the set of indifference curves in the sense of a Pareto preference. The preference axioms of Fishburn (1970) provide an example of axioms with a scalar utility function. In the case of Pareto preference, the axiom of a weak order, especially the negative transitivity,

$$(\text{not } Q \geq Q', \text{ not } Q' \geq Q'') \Rightarrow \text{not } Q \geq Q'',$$

is not fulfilled; and the axiom of a strict partial order does not hold, nor does the conclusion that one of three cases should always hold: $Q < Q'$, $Q' < Q$, or $Q' \sim Q$ (indifference). The Pareto preference and its indifference curves can be estimated using experimental data. For example, we choose some control vectors and determine the corresponding points Q^1, Q^2, \dots, Q^N in the criterion plane (see Figure 4.2).

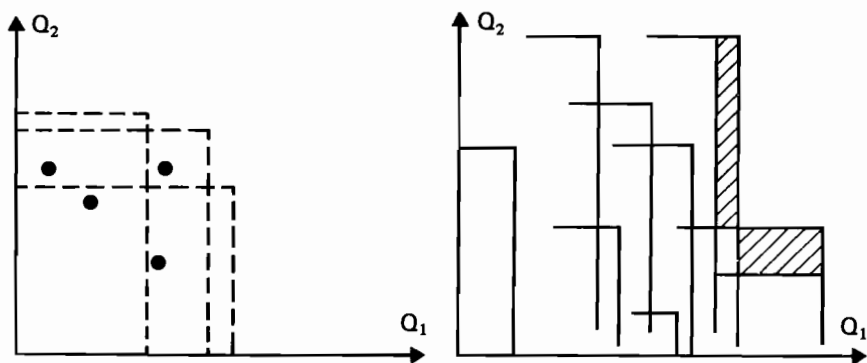

FIGURE 4.2 Example of the criterion plane and the corresponding control points for control vectors of a Pareto preference.

For every experimentally determined point we establish the set of dominated points in the sense of the vector semiorder. All experimental points that are not interior points of such an area form the estimation of the indifference curve, the curve including all efficient points. We remove these optimal points and repeat this procedure for the other experimental points. Thus, we obtain the next "smaller" indifference curve. We continue this procedure until no experimental points remain. The Pareto preference principle is not obligatory, although certain considerations have an axiomatic character. In every situation characterized by a certain point Q in the criterion space, the decision maker knows

- Which points are better. The transitive law holds for the "better relation." If Q^1 is better than Q^2 , and Q^2 is better than Q^3 , then Q^1 is better than Q^3 .
- Which points are worse. The transitive law also holds for the "worse relation." If Q^1 is worse than Q^2 , and Q^2 is worse than Q^3 , then Q^1 is worse than Q^3 .
- Which other points Q'' have no preference in comparison to Q . It cannot be assumed that the indifference relation in general possesses the property of transitivity; on the contrary, small differences that seem to be indifferent in some comparisons can be accumulated through transitivity.

4.2 PROPOSED SOLUTIONS

4.2.1 PROCEDURES TO DETERMINE ONE OR MORE EFFICIENT POINTS

Partial Aims Method

We assume that the criteria are functions of the control variables

$$Q_i = Q_i(x_1, x_2, \dots, x_k) \quad i = 1, 2, \dots, k$$

with continuous derivatives in all variables x_i . The variables x_i are restricted to a control domain

$$(X: f_j(x) \leq 0, \quad j = 1, 2, \dots, m).$$

At every stage of our search procedure we are at a certain criterion point Q^1 . To obtain a better point in the criterion space we try to reach a point $Q^2 = Q^1 + v\Delta Q$. The increment $\Delta Q > 0$ is a nonnegative vector; it is $v_i = 1$ if we want the criterion Q_i to be maximized, and $v_i = -1$ if we want Q_i to be minimized. At the control vector x^1 , which realizes Q^1 , we seek an increment Δx , with $x^2 = x^1 + \Delta x$; thus, x^2 realizes Q^2 . Because in general the transformation $Q = Q(x)$ consists of nonlinear functions, we want to determine the Δx with the help of a linear approximation.

We solve the following system of linear equations:

$$V_i \Delta Q_i = \sum_{j=1}^n \left[\frac{\partial Q_i}{\partial x_j} \right]_{x=x^1} \Delta x_j \quad i = 1, 2, \dots, k$$

With the derived Δx_j we obtain criterion values \tilde{Q}^2 , which differ from the desired criterion values Q^2 because of the approximate character of the linear equations. A test can be designed to determine which components show the desired tendency.

For the determination of the next increment, ΔQ , we use the following statement:

$$\Delta Q_i = \begin{cases} s_i \Delta Q_i & \text{if } \Delta \tilde{Q}_i \geq 0, \text{ and } x^2 \in X; \\ -\Delta Q_i - s_i \Delta Q_i & \text{if } \Delta \tilde{Q}_i < 0, \text{ or } x^2 \notin X. \end{cases}$$

The constraints $s_i \geq 0$ are step-width parameters that can be modified by an evolution law, $s: = f(s, K, L)$, in which K is a parameter having the smallest possible value of the step width and L determines the rate of decrease of the step widths. This search procedure ends when the Q_i lie within tolerance limits ξ_i .

Some remarks about solving the linear equations are appropriate here. Thus,

$$V_i Q_i = \sum_{j=1}^n f_{ij} \Delta x_j, \quad \text{with } f_{ij} = \frac{\partial Q_i}{\partial Q_j}.$$

As long as we are searching within the domain X , the rank of the Jacobian $F = (f_{ij})$ will be k and it will diminish on the boundary of the domain $Y = Q(X)$. When we approach the neighborhood of efficient points, the condition of the matrix will worsen. To reach an efficient point, we need a procedure for the solution of the linear system of equations that is insensitive to the rank of the matrix. Any procedure that exploits pivot elements can be used in principle. We propose the following procedure.

After changing the order of the sequence Q_i we can express the system of equations as

$$V_i \Delta Q_i = (f_i, \Delta x) \quad \text{with } f_i = (f_{i1}, f_{i2}, \dots, f_{in}).$$

The sequence ΔQ_i can be chosen in such a way that f_1 contains the element of (f_{ij}) with the largest absolute value; f_2 contains the element of (f_{ij}) without the elements f_1 with the largest absolute value; and so on. With the use of an algorithm described in Peschel (1975) we determine dual vectors e^j with $(f_i, e^j) = \delta_i^j$. If we observe that one vector, f_{i_0} , nearly is a linear combination of previously considered vectors, f_i , we discard f_{i_0} , thus gaining an additional degree of freedom for the determination of Δx .

Let us first consider the case in which the rank $(f_{ij}) = k$. We can then immediately solve the equation

$$vQ = \sum \Delta x_i f_i$$

for the vectors f_i that are k linearly independent (without restriction we assume these are the first k of the vectors), obtain the solution

$$\Delta x_i = (vQ, e^i) \quad i = 1, 2, \dots, k,$$

and the $\Delta x_j, j = k + 1, \dots, n$ can be freely chosen. For the Δx_j we organize a search procedure,

$$\Delta x_j := \begin{cases} t_j \Delta x_j & \text{if } x^2 \in X \\ -x_j - t_j \Delta x_j & \text{if } x^2 \notin X \end{cases},$$

with an evolution law for the step width of the $t_j \geq 0$. This holds if in the last step the variable x_j was a free variable; otherwise, we start anew with

$$\Delta x_j := \frac{t_0}{k} \left[(f_1, f_1) + (f_2, f_2) + \dots + (f_k, f_k) \right]^{1/2}.$$

Antiparallel Gradients Method

In section 4.1.2 we established that at all efficient points for a vector-maximization problem the condition of antiparallel gradients holds such that

$$\text{grad } Q_2 = -\mu \text{ grad } Q_1, \quad \text{with } \mu > 0.$$

The efficient curve between the extrema of Q_1 and Q_2 can be parameterized with μ . We can use this result for approaching the efficient curve P_2 if we are within the domain Y or we can go along the efficient curve if we start at a point that already lies on P_2 . We demonstrate this method only for the case of two criteria, but it can be extended to the general case. If there are existing constraints, we will have a curve of stationary points in the control space with branches, only one of which will allow us to approach the efficient curve.

Let us assume that all criteria Q_i are strictly concave functions having

$$p_1 Q_i(x^1) + p_2 Q_i(x^2) \geq Q_i(p_1 x^1 + p_2 x^2),$$

with $p_i \geq 0$ and $p_1 + p_2 = 1$. We use the following heuristics for the search procedure: if we build at an arbitrary point of the control domain X the two vectors $a_1 = \text{grad } Q_1 / \|\text{grad } Q_1\|$ and $a_2 = \text{grad } Q_2 / \|\text{grad } Q_2\|$, then the vector

$$a = a_1 + a_2$$

points in the direction of the efficient curve. We modify a_2 by a factor $E, E \geq 1$ and form the following search step:

$$\Delta x = a(a_1 + a_2), \quad \text{with } a = d / \|a_1 + a_2\|.$$

The factor E operates in such a way that we can approach the efficient curve beginning within the control domain X and can also proceed on the efficient curve in the direction of the extremum point of Q_2 . By varying E , the sensitivity of the

algorithm can be adapted according to the distance from the efficient curve. The algorithm is most sensitive for $E = 1$, for then the search point rapidly approaches the efficient curve, and will stop there if we do not let E increase. If we increase E , we obtain an oscillation around the efficient curve with a tendency to lead in the direction of $Q_{2 \max}$. Through appropriate modification of these heuristics, E can be chosen as a function of the sensitivity of the algorithm and can thus influence the sensitivity at the subsequent step. Experience shows that the best limit for the step width d is

$$d \leq 0.1 \|x_{E1} - x_{E2}\|,$$

x_{E1} and x_{E2} are the best controls for $Q_{1 \max}$ and $Q_{2 \max}$, respectively.

Stochastic Search Procedure

A stochastic search procedure with an increment Δx in the control domain X leads to a better control point $x^1 + \Delta x$ in the sense of vector optimization if we obtain a corresponding increment ΔQ in the criterion space with

$$Q = Q(x + \Delta x) - Q(x) \geq 0.$$

The corresponding probability can be expressed as $p = P(\Delta Q \geq 0) = \phi/2\pi$, where ϕ is the angle between the two gradients $\text{grad } Q_1$ and $\text{grad } Q_2$ of the search point x^1 . Obviously, the probability of obtaining better stochastic search points diminishes as we approach the efficient curve.

Often we work in stochastic search procedures with a termination rule, which depends on the number of consecutive failures, but a termination rule cannot operate well in our case because we have to await a great number of failures.

We assume that we have a measurable control domain with the volume V . In our procedure we use an equal distribution of stochastic points in the control domain; in other words, we have to work with a probability distribution of the form

$$f(x_1, x_2, \dots, x_n) = \frac{1}{V}.$$

The stochastic vector x will then be transformed through the functions $Q = Q(x)$ into a stochastic vector in the criterion space. Because of the property that the rank of the Jacobian

$$J = \frac{\partial Q_i}{\partial x_j}$$

displays (i.e., it will diminish from k to $k - 1$, at least if we approach the boundary of Y), the probability density $f(Q_1, Q_2, \dots, Q_k)$ will in every case increase to infinity as we come nearer to the efficient curve. Thus, we obtain the following important property: if we choose some equally distributed points in Y , the corresponding points Q^i in the criterion space will be concentrated near the boundary. We make use of this property if we

1. Choose N equally distributed points $x^i \in X$ and determine the corresponding points Q^i in the criterion space.

2. Select from the set of the N experimental points Q^i only those points that are efficient in the sense of the vector semiorder. This may be the points $Q_1^i, Q_2^i, \dots, Q_M^i$.

3. Establish in an s -neighborhood of the points Q_j^i (perhaps a sphere with the radius s) the N equally distributed points x^i , determine the corresponding points Q^i in the criteria space, and add these to the formerly determined relative efficient points Q_j^i .

4. Proceed with step 2 above as long as the gain in step 3 is significant when measured by a certain distance function or by the number of new points in relation to the formerly determined best points that remain maximal points in the sense of the vector semiorder.

In this case also it is necessary to use a certain evolution mechanism for the step width s , for example,

$$s: = f(s, K, L).$$

Proposals for Dialogue Methods As an Aid to the Decision Maker

With the assistance of a dialogue method the decision maker proceeds to develop the Pareto set P_k of a vector-maximum problem. At every step of such a procedure he must answer the following questions:

1. Is the determined efficient solution acceptable?
2. Which additional demands must be taken into account in the next step?

Because continuous control problems are also of interest, we use one of three different approaches for finding dialogue methods:

- The decision maker demands that lower limits of some components of the criteria vector be taken into account. These are aim-oriented dialogue methods.
- The decision maker accepts previously computed values of some criteria and uses them as lower boundary conditions for a search procedure in the control space. These are obviously control-oriented dialogue methods.
- The decision maker requires that some components of the criterion vector receive better values at the cost of the values of other components. These are also control-oriented methods.

An example of an aim-oriented dialogue method – a modification of the method described in the section on the partial aims method – is as follows.

We assume that we are at a point Q^1 , which has been previously determined to be an efficient point (but in general it is allowed that Q^1 lies within the domain Y).

For a given set of indices i_1, i_2, \dots, i_r , we demand a prescribed amount of increase $Q_{i_j} > 0$. We must solve the system of linear equations

$$vQ = F\Delta x, \quad F = (f_{ij}).$$

We choose the i_j as the first r lines of this system of equations. In some cases we may find contradictions in our demands when we attempt to determine the dual vectors e^j , but these instances will seldom occur. The increase of some ΔQ_j with $j \neq i_1, \dots, i_r$ can be derived by linear dependency; other ΔQ_j can be chosen freely, so we have additional degrees of freedom in choosing the values of Δx_j . We use these degrees of freedom in Δx_j to maximize the most interesting criteria Q_{i_j} to the extent possible. If no degrees of freedom remain, we can be certain that we have reached one efficient point within a tolerance area that best satisfies our demands. By examining the properties of this point, we can decide to stop the process or to continue with modified demands to the components of the criteria vector.

An example of a control-oriented dialogue method might be a case in which a decision maker at an actual point Q^1 of the criterion space formulates the following.

He decomposes the index set $K = (1, 2, \dots, k)$ into three disjoint sets J , S , and M :

$$K = J \cup S \cup M; \quad J \cap S = J \cap M = S \cap M.$$

He then formulates the conditions:

- Q_j with $j \in J$ will result in better values.
- Q_s with $s \in S$ will result in values that are not worse than those obtained previously.
- Q_m with $m \in M$ are of no interest at this stage.

From these conditions he derives two subsets of criteria:

- Q_j with $j \in J \cup S$, which cannot result in worse values, $N = J \cup S$.
- Q_m with $m \in M = \bar{N}$, which can result in worse values.

We assume that all criteria are concave functions of their arguments and that X is a convex domain; in this case, all points of the Pareto set P_k can be determined by a global linear compromise,

$$Q = \sum \lambda_i Q_i \rightarrow \max.$$

At the point Q^1 we have the vector parameter λ_j^1 . We consider the point Q^1 as a special compromise between two linear compromises in the following way:

$$Q^1 = d_1 \left(\sum_{n \in N} c_n Q_n \right) + d_2 \left(\sum_{m \in M} c_m Q_m \right)$$

with

$$\lambda_n^1 = d_1 c_n, \quad \sum c_n = 1; \quad \lambda_m^1 = d_2 c_m, \quad \sum c_m = 1.$$

During the dialogue we vary the linear compromise between the coefficients d_i and show the efficient curve between

$$Q'_1 = \sum_{n \in N} c_n Q_n \quad \text{and} \quad Q'_2 = \sum_{m \in M} c_m Q_m$$

to the decision maker. If we follow the direction of a maximum of Q'_1 and discover that one of the Q_n results in worse values, the demands of the decision maker become contradictory. Then we must terminate this subprocess, and the decision maker must formulate new conditions. This must also be done if one of the secondary criteria Q_m assumes worse values.

4.2.2 LONG TIME HORIZONS

For many decision-making problems some foresight is necessary. We consider these problems as vector-optimization problems for dynamic systems. We must have some sort of extrapolation or prognosis model of our system for the future. In these cases we consider the decision making as a step-by-step decision process and assume that in every decision the vector criterion Q has a certain increase ΔQ_j , depending on a local control vector y^i and an actual-state vector z^i :

$$\Delta Q_j = q_j(z^i, y^i).$$

The decision y^i causes the state z^i of the system to evolve to some other state z^{i+1} ; the evolution equation takes the form $z^{i+1} = g(z^i, y^i)$. We next establish Bellman's functional equation for the optimality criteria and for the case of a vector criterion. Difficulties occur, however, if we want to use proposed methods for determining the Pareto set P_k^i at every step beginning with the last step in the future.

On the one hand, if we use only necessary conditions for the points of P_k^i , the set of solutions that are not maximum points in the sense of vector semioorder will increase. On the other hand, if we prefer to use sufficient conditions for the points of P_k , we discard an increasing number of points at every step of the decision process, a procedure similar to applying a branch-bound algorithm, although we cannot determine if the "most efficient" points will remain.

4.2.3 TWO GROUPS WITH DIFFERENT INTERESTS

Let us assume that there are two groups of people, one group with a vector criterion $Q(I)$ and the other with $Q(II)$. The groups have individual control vectors

m^I and m^{II} at their disposal and search for an efficient point of their individual Pareto sets $P_k(I)$ or $P_k(II)$. In general, this is not a simple task. The process used by the first group (decision maker I) is interconnected with the process of the second (decision maker II) and vice versa; these interconnections are disturbances for the individual controls of the two decision makers.

There are two possibilities for treating this situation. One approach is for the individual decision maker to consider these disturbances as stochastic influences and to attempt to overcome them. The other possibility is to choose a third party as a coordinator, a person who is neutral and who has sufficient knowledge about both decision makers' objectives that he can coordinate their individual decisions in such a manner that neither of them loses. This third person is also a decision maker, yet he must follow a certain coordinating strategy. Perhaps he himself has some interests. These interests of the decision maker on the higher level may have a greater priority compared with the interests of the decision makers at the first level. Such a hierarchy of systems, each with its individual decision maker, must be organized so that contradictions will not develop between the aims of the decision makers at the lower level or between the interests of the decision makers at the lower level and those of the decision maker at a higher level.

Thus, we demand that the so-called efficiency axiom must hold: every subsystem should find an acceptable decision point in its individual Pareto set, which moves along this Pareto set, if some other interests from the same or higher levels demand some coordinating strategy. If we demand that all subsystems be controlled with an efficient point according to the individual vector-optimization task, the decision maker on the higher level can use as coordinating variables only the additional influences he asserts on the subsystems or the degrees of freedom that are left to him.

An example of this process is a process to be optimized that consists of three subprocesses with the following individual criterion functions:

Subprocess 1

$$Q_1 = x_1^2 + 2x_2^2 + 1.5x_3^2 + x_3 - 4x_1 - 1 + s_{21}.$$

Subprocess 2

$$Q_2 = x_1^2 + 2x_2^2 + 1.5x_3^2 + x_3 + s_{32}.$$

Subprocess 3

$$Q_3 = 3x_1^2 + 7x_2^2 + 5x_3^2 + 2x_1x_2 + 4x_1x_3 + 6x_2x_3 - 16x_1 - 29x_3 + s_{13}.$$

The process model is characterized by the following equations:

Subprocess 1

$$s_{13} = -20x_1 + 5s_{21} + 46.$$

Subprocess 2

$$s_{21} = -16x_2 + s_{32} + 1.$$

Subprocess 3

$$s_{32} = -2x_3 - 0.2s_{13} + 28.2.$$

A set of three constraints is given as

$$f_1: x_1 \leq -12x_2 - 3x_3 + 30.$$

$$f_2: x_2 \leq -0.49x_1 - 1.51x_3 + 1.25.$$

$$f_3: x_3 \leq 0.39x_1 - 0.98x_2 + 1.87.$$

The solution of the coordination according to the global criterion

$$Q = Q_1 + Q_2 + Q_3 = \min$$

is given together with other efficient control vectors for weighting coefficients different from $\lambda_1 = \lambda_2 = \lambda_3 = 1$ in Figure 4.3. There are two projections of the curve of efficient control vectors between the individual minima of Q_2 and Q_3 that cross the point of optimal control for the minima. In Figure 4.3 the intervals of the efficient control curve with active constraints are marked by f_3 for f_3 active; f_3 and f_2 for f_3 and f_2 active; and f_2 for f_2 active. The relative error found in applying the algorithm of Fishburn (1970) was equal to 0.5 percent.

4.2.4 MULTIOBJECTIVE DECISION MAKING UNDER UNCERTAINTY

In general we cannot assume that the relationship between the criteria and the control variables can be reliably described with the help of deterministic equations; in the case of decision making over time we cannot assume that the extrapolation model of systems behavior can be described as the behavior of a deterministic automaton. Therefore, it is necessary to introduce into the methods of decision making a description of the fuzziness of the phenomena. The description of stochastic influences with probability theory is only one of many possibilities we have at our disposal using the fuzzy-set concept.

We first describe an algorithmic approach based on fuzzy-set theory, in which we have already introduced promising results using stochastic search procedures (Riedel, 1975). Later we present more generalized considerations in terms of fuzzy relationships.

A procedure for simultaneous searching in the objective space and the control space is as follows.

We describe the optimum efficient point Q for which we are searching in the objective space by a fuzzy set Q' having a membership function $f(Q, Q')$. The value $f(Q, Q')$ has the following significance: it is a measure of the chance that point Q is

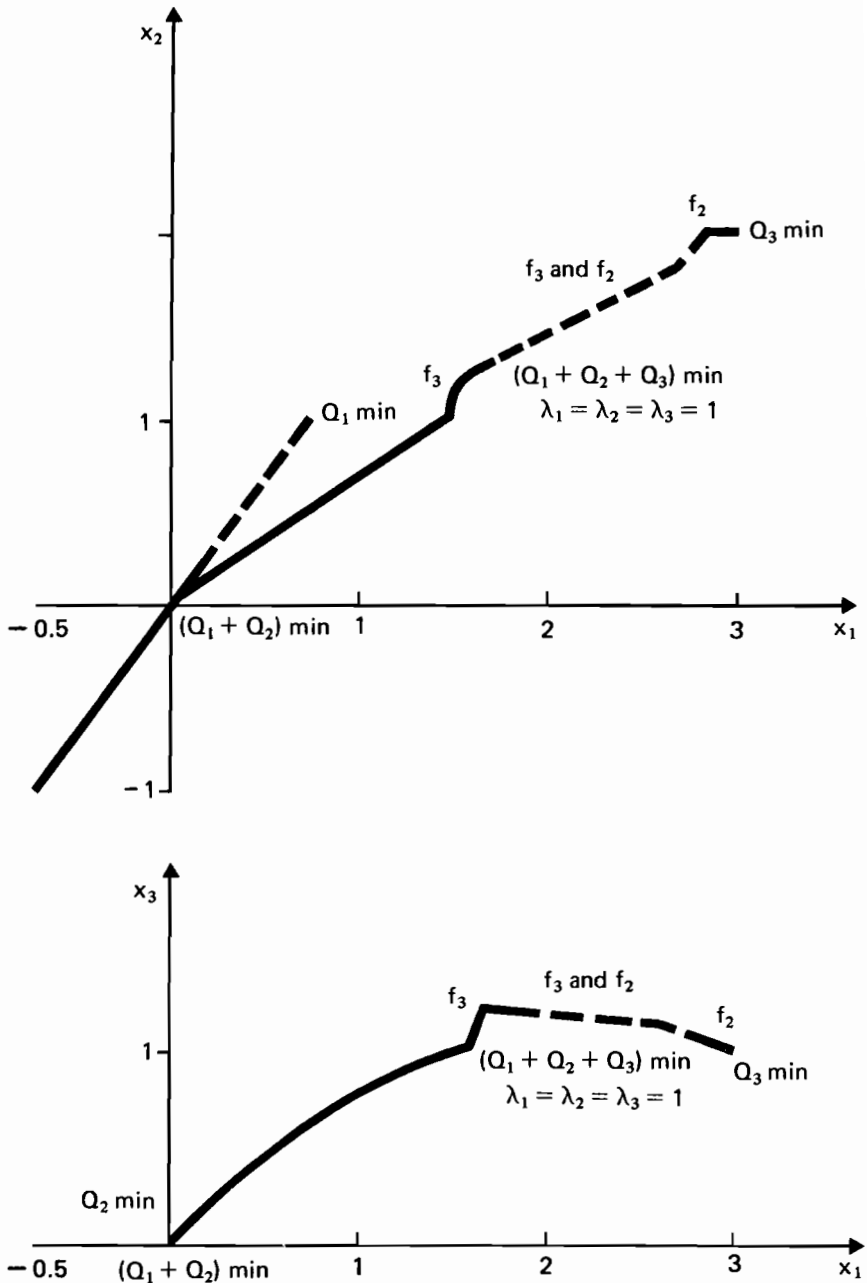

FIGURE 4.3 Efficient control vectors for different weighting coefficients.

the optimal point Q' , the position of which is unknown. During the process of approaching (developing) better values for the vector criterion, the fuzziness described by the membership function $f(Q, Q')$ must decrease. Therefore, we need a strategy for modifying $f(Q, Q')$ in a manner that automatically takes into account our increasing knowledge about the vector criterion. The same remark also holds for $f(x, x')$, which describes in a similar way the fuzziness of the corresponding control vector x' in the control space. Our procedure has six steps.

The first step is to choose a set of equally distributed points q^i in the parameter space. We construct elementary membership functions $f_{\Delta}(q; q^i)$, taking uncertainty into account in producing the single control q^i . We compute or measure corresponding points Q^i in the criterion space and describe them by the elementary membership functions $f_{\Delta}(Q; Q^i)$, which allow for computation or measurement errors. According to the section on stochastic search procedure, above, the points Q^i will condense in the neighborhood of the boundary of the domain Y in the criterion space.

Second, we estimate by a sequential procedure the membership functions $f(Q; Q')$ and $f(q; q')$. In this estimation procedure we reward the elementary membership functions $f_{\Delta}(\cdot; \cdot)$ if they are efficient. From the current estimation $f^*(Q; Q')$ we determine the optimum decision point

$$Q'^* \leftarrow \max f^*(Q; Q').$$

We compare Q^i with Q' by evaluating

$$d(Q^i, Q'^*) = \sum_{j=1}^k f_j(Q_j^i - Q_j'^*).$$

Herein we use $f_j(u)$ with $uf_j(u) > 0$ as reward functions. Taking the values $d(Q^i, Q'^*)$ as weighting coefficients we obtain the following sequential estimation procedure:

$$f^*(Q; Q') := \max [f^*(Q, Q'), d(Q^i, Q'^*) f_{\Delta}(Q, Q^i)] \quad i = 1, \dots, N$$

$$f^*(q, q') := \max [f^*(q, q'), d(Q^i, Q'^*) f_{\Delta}(q, q^i)]$$

The third step is to design the search point q^{i+1} for the subsequent experiment

$$q^{i+1} \leftarrow \max [f^*(q, q')].$$

By measurement or computation we determine the corresponding point

$$Q^{i+1} = Q(q^{i+1}),$$

and compute the elementary membership function $f_{\Delta}(Q, Q^{i+1})$ as we did previously and $f_{\Delta}(q, q^{i+1})$ through the following modification:

$$f_{\Delta}(q, q^{i+1}) := g_{\Delta}(q, q^{i+1}) f^*(Q^{i+1}, Q'),$$

using $g_{\Delta}(q, q^{i+1})$ as an impulse shape employed in the first step above. The weighting factor $f^*(Q^{i+1}, Q')$ provides a better chance to achieve results Q^{i+1} having greater values, bringing us closer to efficient point Q' .

The fourth step is to discount the formerly received estimations

$$f^*(Q, Q') = \max [(1-s)f^*(Q, Q'), d(Q^{i+1}, Q'^*)f_{\Delta}(Q, Q'^{+1})]$$

$$f^*(q, q') = \max [(1-s)f^*(Q, Q'), d(Q^{i+1}, Q'^*)f_{\Delta}(Q, Q'^{+1})]$$

with the discount factor $0 \leq s \leq 1$.

Fifth, we must establish an evolution law for the discount factor s . From our experience with stochastic extrema search methods we use for the variation of s the following evolution law:

$$s = \frac{K}{\left(1 + \frac{L}{s}\right)}, \quad \text{with } K \ll 1.$$

L is linearly interpolated between two values, L_1 and L_2 , with $L_1 \ll L_2$ and the use of the formula

$$L = \frac{L_2 - d_s(L_2 - L_1)}{(d_s - d(Q^i))}, \quad \text{with } d(Q^i) = \sum_{j=1}^k f_j(Q_j^i).$$

Here, d_s is a fixed upper value at which the decision maker will be satisfied.

As a final step six, if the decision maker is not yet satisfied, return to step three.

4.3 APPLICATION: DESIGN OF OPTIMAL SWITCHING CIRCUITS FOR MACHINE TOOLS

Numerically controlled machine tools offer an example of application in which we meet the problem of stopping a support that initially moves with a velocity v_0 at a given position L , using only a negative acceleration b . We want to transfer the support into the position L in a minimum transfer time T . According to the theory of time-optimal control, the optimal motion has in the phase plane (x, y) a form like that shown in Figure 4.4.

The support moves with the velocity v_0 until it reaches the position x_0 ; at that point the negative acceleration b is introduced, and the system runs on a parabola to position L , where it arrives with the velocity 0. On a numerically controlled machine tool this strategy cannot be realized because comparisons of the positions are possible only at time points in a sequence with period τ . It can be assumed that the stochastically occurring lag time is equally distributed in an interval $(0, \tau)$.

In general, an overrun distance of $\Delta_0 = v_0\tau$ occurs at the position L , which lies beyond the allowed tolerance. To remove this effect we introduce a sequence of intermediate velocities $v_0 > v_1 > v_2 > \dots > v_m$. From v_0 we switch to v_1 , and then we run the support with constant velocity v_1 until we reach a coordinate x_1 , when we again apply the negative acceleration until we reach the next velocity level v_2 . We continue with this velocity to position x_2 and proceed in this way

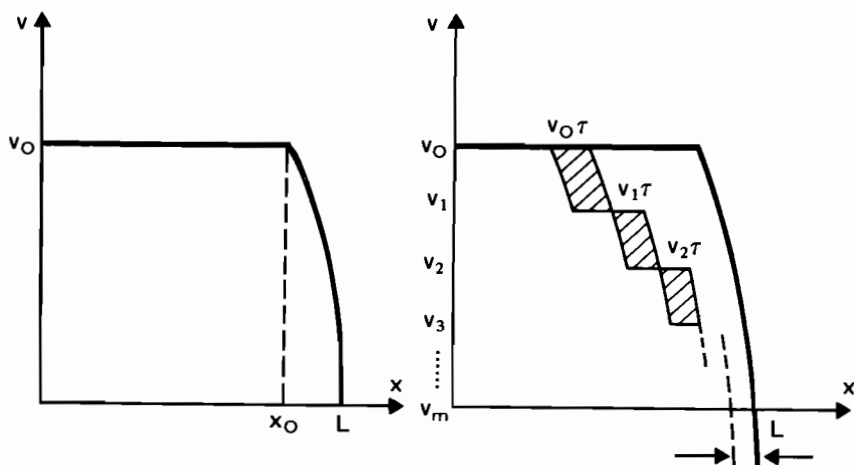

FIGURE 4.4 Time-optimal control: the form of optimal motion in the phase plane (x, v) .

until we reach the last velocity level v_m , which has a corresponding overrun distance $\Delta = \Delta_m = v_m \tau$ and lies within the allowed tolerance at the position L .

The corresponding coordinates x_i must be chosen so that there is no point in the future when we intersect the ideal parabola (Figure 4.4). This demand can be fulfilled only if we allow at every velocity level v_i the maximum possible overrun level for all preceding velocity levels. Under this condition we obtain for the strategy of m -tuple τ -levels the following equations:

$$x_m = L - \frac{v_m^2}{2b} - \Delta$$

$$x_{i-1} = x_i - \Delta_{i-1}, \quad \Delta_{i-1} = v_{i-1} \tau + \frac{v_{i-1}^2 - v_i^2}{2b} \quad (i = 1, 2, \dots, m).$$

For x_0 we obtain

$$x_0 = L - \frac{v_0^2}{2b} - \Delta - \tau \sum_{i=0}^{m-1} v_i.$$

The elementary step on the velocity level v_i requires the time

$$T_i = \tau_i + \frac{v_i - v_{i-1}}{b} + \frac{v_i}{v_{i+1}} (\tau - \tau_i).$$

In comparison with the ideal motion, we obtain the stochastic time increment

$$\Delta T - \tau \sum_{i=0}^{m+1} \left(\frac{v_i}{v_{i+1}} - \frac{v_i}{v_0} \right) + \sum_{i=0}^{m-1} \tau_i \left(1 - \frac{v_i}{v_{i+1}} \right) + \tau_m - \tau \frac{v_m}{v_0}.$$

The control variables are the number of levels m , the values of levels v_1, v_2, \dots, v_{m-1} , and the stochastic lag times $\tau_0, \tau_1, \dots, \tau_m$. The stochastic influence leads to a search for a strategy that is optimum in the mean; we use mean value and variance as the first two objectives. For these objectives we obtain the following expressions:

$$Q_1 = \frac{M(\Delta T)}{\tau} = \frac{m+1}{2} - \frac{v_m}{v_0} + \sum_{i=0}^{m-1} \left(\frac{v_i}{2v_{i+1}} - \frac{v_i}{v_0} \right)$$

$$Q_2 = \frac{\delta^2(\Delta T)}{\tau^2} = \frac{1}{12} \left[1 + \sum_{i=0}^{m-1} \left(1 - \frac{v_i}{v_{i+1}} \right)^2 \right].$$

A third objective is the required positioning tolerance

$$Q_3 = \frac{\Delta}{\Delta_0} = \frac{\Delta_m}{\Delta_0} = \frac{v_m}{v_0} = \frac{1}{s}.$$

The compromise situation is shown for Q_1 and Q_3 in Figure 4.5 and for Q_1 and Q_2 in Figure 4.6. From Figure 4.5 we obtain the necessary number m velocity levels for the minimum of Q_1 :

$s \leq s_0$	3	11	42	165	644	2,521
m	1	2	3	4	5	6

For given values of Q_3 we obtain the Pareto set after computing the minimum of the linear compromise

$$Q = \lambda_1 \left[\frac{1}{2} \sum_{i=0}^{m-1} \phi_i - \frac{1}{s} \left(s + \phi_1, \dots, \phi_{m-1} + \phi_2, \dots, \phi_{m-1} + \phi_{m-1} \right) \right]$$

$$+ \lambda_2 \sum_{i=0}^{m-1} (1 - \phi_i)^2 - \mu \phi_0 \phi_1, \dots, \phi_{m-1}.$$

We find the following solution for $\phi_i = \frac{v_i}{v_{i+1}}$:

$$\phi_0 = \frac{1}{2} \left(1 - \frac{\lambda_1}{4\lambda_2} \right) + \sqrt{\frac{1}{4} \left(1 - \frac{\lambda_1}{4\lambda_2} \right)^2 + \mu \frac{s}{2\lambda_2}}$$

$$\phi_i = \frac{1}{2} \left(1 - \frac{\lambda_1}{4\lambda_2} \right)$$

$$+ \sqrt{\frac{1}{4} \left(1 - \frac{\lambda_1}{4\lambda_2} \right)^2 + \mu \frac{s}{2\lambda_2} + \frac{\lambda_1}{4\lambda_2} \left(\frac{1}{\phi_0} + \frac{1}{\phi_0\phi_1} + \dots + \frac{1}{\phi_0\phi_1 \dots \phi_{m-1}} \right)}.$$

Figure 4.7 shows the necessary number of velocity levels dependent on the positioning tolerance s and the compromise parameter λ_1 .

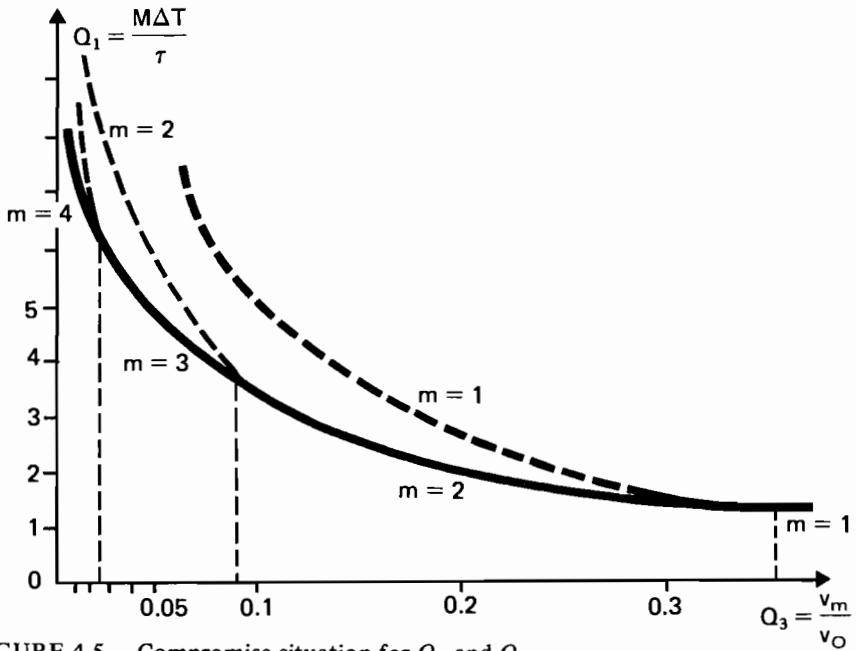

FIGURE 4.5 Compromise situation for Q_1 and Q_3 .

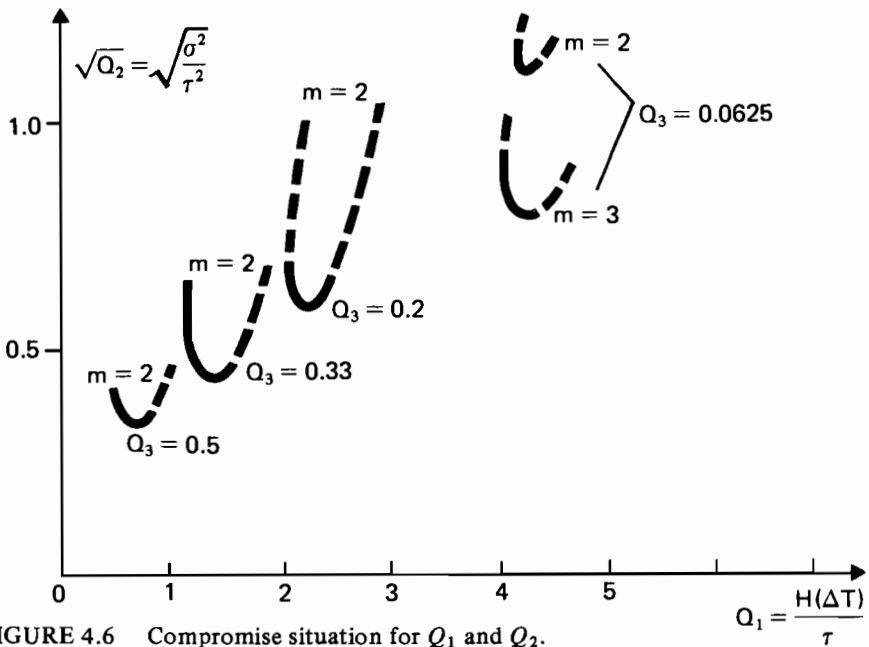

FIGURE 4.6 Compromise situation for Q_1 and Q_2 .

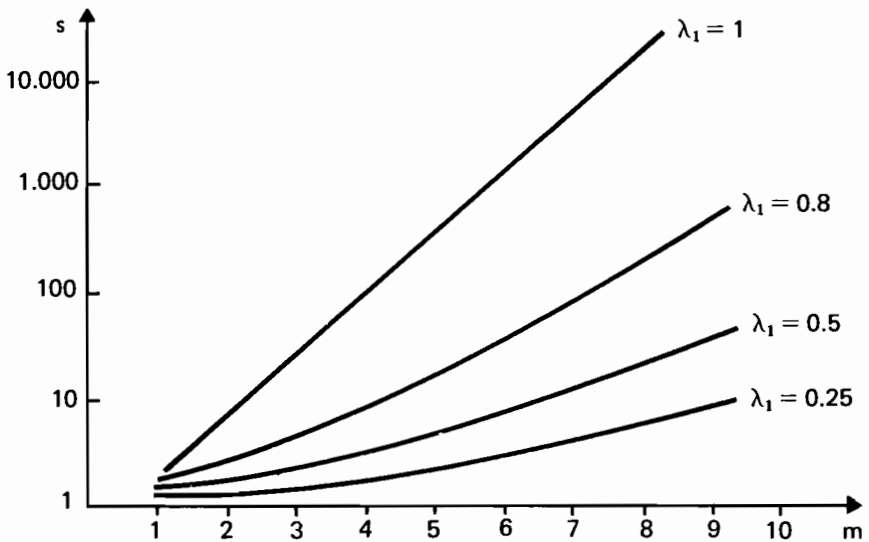

FIGURE 4.7 Velocity levels dependent on the positioning tolerance s and the compromise parameter λ_1 .

REFERENCES

- Bachmann, G.K., H. Elster, and M. Petry. 1973. On the problems of geometric optimization. (In German.) *Wissenschaftliche Zeitschrift der Technischen Hochschule Ilmenau*, Vol. 19, pp. 13–39.
- Dinkelbach, W. 1969. *Sensitivity Analysis and Parametric Programming*. (In German.) Springer-Verlag, Berlin.
- Düch, W., and M. Bliefenrich. 1972. *Operational Research*. (In German.) VEB Deutscher Verlag der Wissenschaften, Berlin, 2 vols.
- Duffin, R.J., E.L. Peterson, and C. Zener. 1967. *Geometrical Programming*. John Wiley, New York.
- Emel'ianov, S.V. 1972. Models and methods for vector optimization. (In Russian.) Preprint. Institute for Control Problems, Moscow.
- Ester, J. 1975. A compromise strategy for the statistical optimization of additive and vector quality functions. (In German.) Dissertation, Technische Hochschule, Karl-Marx-Stadt.
- Ester, J., M. Peschel, and C. Riedel. 1975. Polyoptimal Approach to the Control of Hierarchical Multilevel Systems. In *Sixth World Congress of IFAC*. Boston, Vol. IIIA.
- Fandel, G. 1972. *Optimal Decisions with Multiple Objectives*. (Lecture Notes in Economics and Mathematical Systems, Vol. 76.) (In German.) Springer-Verlag, Berlin.
- Fishburn, P. 1970. *Utility Theory for Decision Making*. John Wiley, New York.
- Focke, J. 1973. The vector-maximum problem and parametric optimization. (In German.) *Mathematische Operationsforschung und Statistik*, Vol. 4, pp. 365–369.
- Griessbach, V., and F. Krauss. 1974. Contribution to the examination of the constitution of the properties of rubber in pressure die cast tools. (In German.) Dissertation, Technische Hochschule, Faculty of Mechanical Engineering, Karl-Marx-Stadt.

- Heilmann, P.W. 1974. Selection and optimal positioning of driving forces for electrically operated road vehicles. (In German.) Dissertation, Technische Hochschule, Faculty of Electrical Engineering, Karl-Marx-Stadt.
- MacCrimmon, K.R. 1972. An overview of multiple objectives decision-making. In *Multiple Criteria Decision Making* (J.L. Cochrane and M. Zeleny, eds.). University of South Carolina Press, Columbia.
- Peschel, M. 1965. Investigations into the idea of convexity. (In German.) Dissertation, Humboldt University, Faculty of Mathematics and Natural Sciences, Berlin.
- Peschel, M. 1972. *Statistical Modelling*. (In German.) Series on Automation Techniques, Vol. 173. VEB Verlag Technik, Berlin.
- Peschel, M. 1974. *Statistical Determination of Characteristic Values*. 2nd ed. (In German.) Series on Automation Techniques, Vol. 125. VEB Verlag Technik, Berlin.
- Peschel, M. 1975. The use of a dual basis for the determination of characteristic values in parametric-linear models (linear regression). (In German.) *Messen, Steuern, Regeln*, Vol. 4, pp. 120–122.
- Peschel, M., and C. Riedel. 1975. *Polyoptimization – A Decision-Making Aid for Technical Engineering Compromise Solutions*. (In German.) VEB Verlag Technik, Berlin.
- Riedel, C. (ed.). 1975. *Polyoptimization – Contributions to Optimization with Multiple Objectives*. (In German.) Technische Hochschule, Karl-Marx-Stadt.
- Russig, A. 1968. The use of numerically controlled machine tools. (In German.) Paper presented at the International Colloquium on Machine Tools, Technische Universität, Dresden.
- Straszak, W. 1972. Polyoptimization of large-scale systems with multilevel control structure. In *Fifth World Congress of IFAC*. Paris.
- Strejc, V. 1970. *The Scaling of Continuous Linear Feedback Control Systems in Practice*. Series on Automation Techniques, Vol. 97. VEB Verlag Technik, Berlin.

DISCUSSION

KURZHANSKI: Is the set of efficient solutions stable with respect to changes in the initial data? And is your algorithm stable with respect to perturbations?

PESCHEL: Yes. In the examples we have solved, although no mathematical theory predicts stability, we have found that perturbations did not greatly affect the final solution.

ZALAI: Have you considered looking for trade-offs that would enable you to restrict the dimension of the search? Your methods are reasonable for two criteria, but in higher dimensions there may be difficulties. It would not be wise to let the opportunity sector be too wide.

PESCHEL: Yes, if we can find such a restriction it would be useful to introduce them. One condition, however, must remain true. The number of controls minus the number of active constraints must be greater than the number of objectives, otherwise the algorithm is not applicable.

WEGENER: Your procedures work toward finding optimal criteria, the Q , rather than optimal level of decision variables, the x . In your examples the relationship between the Q and x were quite straightforward, but suppose that this relationship were not clear, what could you do then? In social systems this relationship is most complex; would your methods work in these cases?

PESCHEL: We have not applied these techniques to social systems, although we have applied them to industrial systems. For example, we have a time theory for

the load sequence of an energy system. We are seeking a fuzzy relationship between the consecutive loads in the sequence to make this forecast. I think the approach of using fuzzy relationships is a good one, because you can use it as a surrogate for the behavior of the system.

ZALAI: I would answer Mr. Wegener's question by saying that if you do not know the relationship between the decisions and the outcomes, then you do not have a decision problem.

WEGENER: That is my point.

FISHBURN: This is related to the first question. The relation between the Q and x may depend upon some parameters. Perhaps the first question to some extent asked if perturbations to these parameters affected the final solution. That is, not perturbations to the search procedure but rather to the relations between the actions and the outcomes.

PESCHEL: In the approach I described, we have only tried perturbation to the search process; we have not perturbed the equations. But we have performed an application to heart circulation diagnosis: we had four rough models, and we tried each to determine how the final solution varied among the models.

5 Trade-off Analysis: The Indifference and Preferred Proportions Approaches

*Kenneth R. MacCrimmon and
Donald A. Wehrung*

5.1 INTRODUCTION

Individuals and organizations make decisions in order to attain particular ends. So it follows that a decision maker should evaluate alternatives in terms of the extent to which each alternative will lead to the attainment of these ends. Such ends, or goals, may be considered in terms of a hierarchy in which the goals at the top tend to be abstract (e.g., living the “good life”), and the ones near the bottom tend to be concrete (e.g., owning a house located within 5 miles of place of employment). A decision maker can more easily deal with concrete goals than with abstract ones, so he usually perceives, describes, and evaluates his alternatives in terms of these lower-level goals. To the extent that different decision makers have approximately the same goals, they will describe the alternatives in terms of the same goal-related attributes.

A decision maker often has multiple goals and must consider the multiple attributes of each of the alternatives in terms of his attainment of goals. However, a decision maker attempting to choose among alternatives will almost always find that although one alternative is preferable when one particular attribute is considered, another alternative will be preferred when a different attribute is considered. Seldom will one alternative be superior for every attribute contributing toward the goals. Hence, a decision maker often must accept lower values on some attributes to obtain higher values on others.

Trade-offs of this kind are at the core of multiple-attribute decision making. This paper explores how a decision maker can use trade-offs to express preferences over interdependent attributes and how these trade-offs can help him to make better decisions.¹ To the extent that the decision maker has fully identified the attributes

¹The role of trade-offs in the context of a variety of multiple-attribute decision methods is considered in MacCrimmon (1968, 1973).

and the attributes fully describe his goals, he can base his decision on those attributes. The primary benefit of basing decisions on goal-oriented attributes of alternative actions rather than on the actions themselves is that comparisons of the relative importance of various attributes become the central focus of the decision process. These comparisons can then be made in relation to the decision maker's preferences.

Determining the number and type of attributes to describe an alternative is a complex task, and the more complex the alternatives, the larger the number of possible attributes. The subset of a few (or a few hundred) attributes that the decision maker focuses on is determined by his underlying goal structure. Since the focus in this paper is on trade-offs, we assume that we have identified the attributes that are most important in attaining the decision maker's goals.

We must next decide upon an appropriate way to measure the values of the attributes identified. We can choose to use standard measures, or we can construct special scales. The most complete scales are numerical; they can be used to add and multiply attribute values to obtain meaningful comparisons (e.g., a house that costs \$30,000 is half as expensive as a house that costs \$60,000). Such scales, called ratio scales, are completely defined except for a scale unit. There are other numerical scales, called interval scales, that are less informative and have an arbitrary origin. Numerical scales make a problem easier to deal with, but we are often unable to obtain these scales for every attribute of relevance. If, for example, we are judging the neighborhoods of houses we are interested in buying, we may be able to rank neighborhoods in terms of tranquillity, but we may not be able to develop any meaningful numerical scale. In a situation like this, we can order only the relative tranquillity of the neighborhoods and hence obtain only ordinal scales. Least useful are nominal scales, appropriate for situations in which we can only assign attribute values but cannot even order these (e.g., names of types of heating systems in houses we are interested in buying).

To demonstrate the types of scales and how they can be used in combination, let us consider the multiple-attribute decision of buying a house, focusing specifically on pairs of house attributes used in the examples above. First, let us take two attributes measured numerically: the price of a house and the distance from the house to place of employment. In such a case we may consider changes in both magnitude and direction of each attribute. These attributes are illustrated in Figure 5.1. The dots represent alternative houses. We can say that the difference in price between house *A* and house *B* is the same as the difference in price between *A* and *C*, or that *C* is twice as far from place of employment as *A*, and that *B* is midway between *A* and *C* in distance to work. We can express trade-offs on either attribute; that is, we can talk about the change in distance we would want for a particular change in price or the change in price we would want for a particular change in distance.

Now, suppose we want to consider one attribute that is measured numerically and another attribute that is measured ordinally (Figure 5.2). The numerical

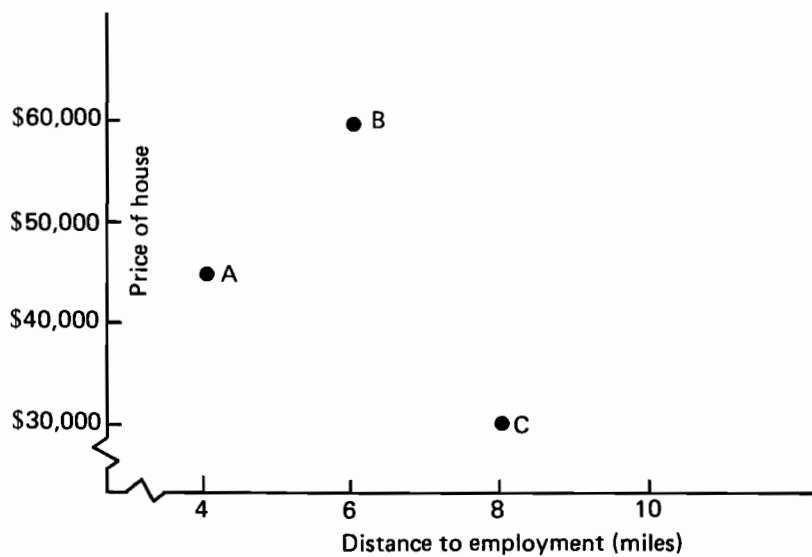

FIGURE 5.1 Two numerical attributes.

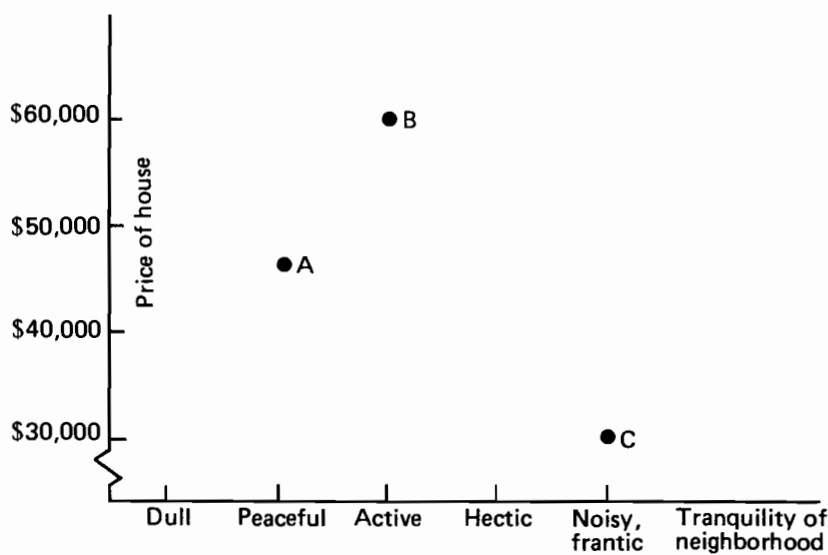

FIGURE 5.2 A numerical attribute and an ordinal attribute.

attribute is the price for houses *A*, *B*, and *C*; the ordinal attribute is the tranquillity of the neighborhood. We assume that we can characterize neighborhoods by their level of tranquillity from dull to frantic but that we cannot express particular amounts of change in tranquillity. All we can say is that house *A* has a more tranquil neighborhood than house *B* and that *B* has a more tranquil neighborhood than *C*. We can say nothing about the magnitude of the differences. We can, nevertheless, express a trade-off by noting the change in price we would want for a particular change in tranquillity, say from a peaceful to an active neighborhood. Although we could also express the change in tranquillity we would want for a particular change in price, the ordinal nature of the tranquillity dimension makes this converse approach less meaningful.

Next, suppose we want to consider one numerical attribute, price of house, combined with one nominal attribute, type of heating system (Figure 5.3). Again, we have the earlier relationship among the prices of houses *A*, *B*, and *C*. However, in considering the type of heating system for these houses, we can say only that they are different; we cannot assert a difference in either magnitude or direction. We can, nevertheless, form trade-offs by considering the change in price we would want for a given change in heating systems. In contrast, it would not be meaningful for us to talk about the change in heating systems that we would want to offset a change in price. In this case, then, when one attribute is numerical and the other is nominal, the trade-off is asymmetrical.

We shall not go on at this point to consider the possible combinations of attributes: ordinal–ordinal, ordinal–nominal, and nominal–nominal. We will be

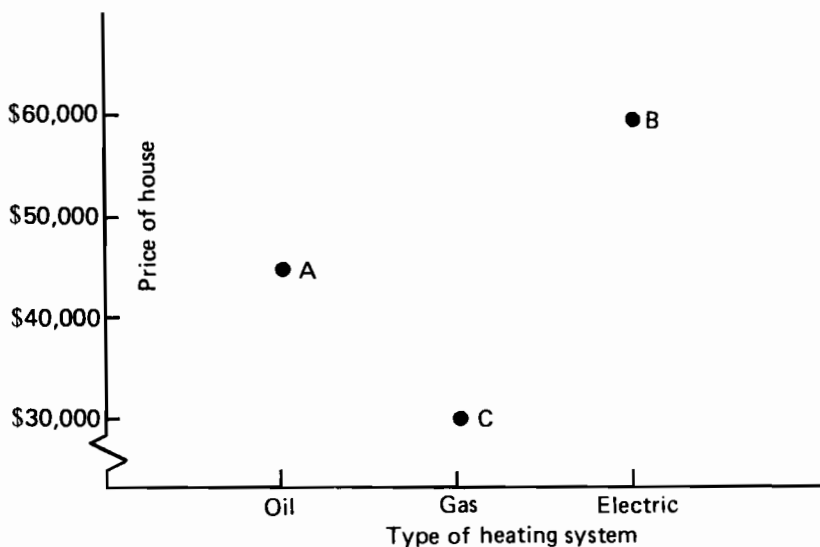

FIGURE 5.3 A numerical attribute and a nominal attribute.

concerned mainly with cases that have at least one numerical attribute so we can obtain a full expression of trade-offs. If such an attribute does not exist in a decision problem as initially defined, it may be possible to introduce a numerical attribute. Obviously, money is an attribute that either enters problems from the outset or can often be introduced to yield meaningful trade-offs. In sections 5.2 through 5.4 each attribute is assumed to be numerically scaled. In subsequent sections we consider trade-offs where some attributes are not numerically scaled.

Note that we do not have to consider trade-offs on all possible values of each attribute we identify. Obviously, some attribute values will be infeasible; that is, some will not correspond to any real alternative. Therefore, in scaling our preferences for particular attribute values, we do not have to consider these infeasible values. In addition, we will probably find some attribute values unacceptable, even though they are feasible. It is these critical values of infeasibility or unacceptability that serve to restrict the relevant attribute space (MacCrimmon, 1969). Although we may be unable to discriminate finely between feasible and infeasible attribute values or between acceptable and unacceptable attribute values, we can probably establish some imprecise boundaries. The main reason for establishing these boundaries is to reduce the amount of information we will have to process in forming our trade-offs. In other words, by placing constraints on the domain of attribute values being considered, we make our decision problem more manageable.

5.2 THE INDIFFERENCE APPROACH VERSUS THE PREFERRED PROPORTIONS APPROACH

In sections 5.2 through 5.4 we will consider trade-offs on attributes that are each numerically scaled. It is easiest to begin with a reference alternative A_0 , defined by two attributes (X_0, Y_0) . We discuss two types of trade-off:

In the *indifference approach*, a trade-off is the change in attribute Y that is necessary to offset a given change in attribute X so that the new alternative, A_1 , is indifferent to A_0 .

In the *preferred proportions approach*, a trade-off is the proportion of change in attributes X and Y that the decision maker would most prefer if he could move away from (X_0, Y_0) in some particular way.

In both these approaches there is a trade-off between the values of X and the values of Y .

To demonstrate the differences between these two approaches, let us reconsider the housing example. Suppose that the attribute X is the price of the house (in thousands of dollars) and Y is the distance to place of employment (in miles). Consider A_0 as a reference point, a house whose price is \$50,000 and whose distance from place of employment is 18 miles. A_0 can be expressed, then, as

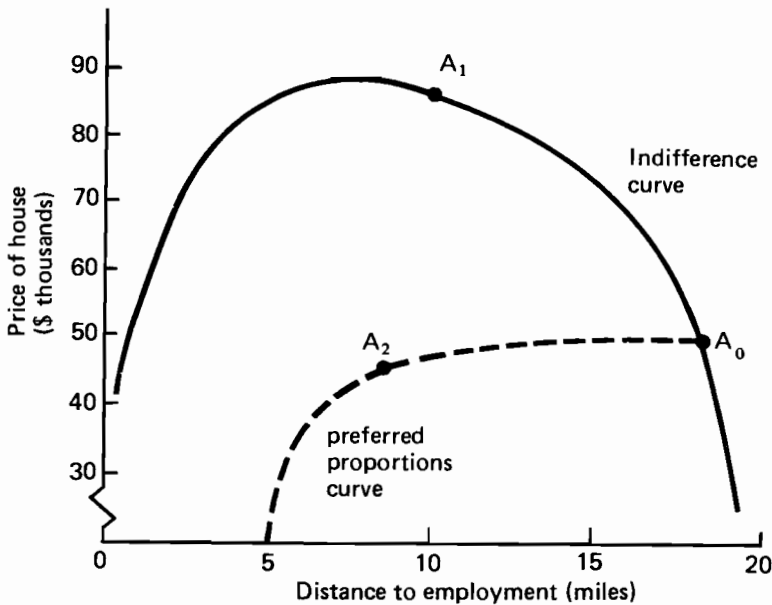

FIGURE 5.4 Comparison of an indifference curve with a preferred proportions curve.

(50, 18), as shown in Figure 5.4. The indifference approach would require a new alternative, say, A_1 (85, 10), that the decision maker would deem equivalent in preference to A_0 . By obtaining a number of such points, we would trace out a curve of indifference through A_0 . The indifference curve is, then, the locus of all attribute values indifferent to a reference point (the solid line in Figure 5.4). The steep slope at the right end of the curve implies that the decision maker is willing to trade off a considerable increment in price in order to live closer to his place of employment when he is 15 to 20 miles away. Around A_1 this slope tends to level off, indicating that the decision maker is not willing to pay much more to live closer than 10 miles from place of employment. At about 5 miles, the curve turns down, implying that the decision maker would never pay more to live closer than 5 miles and would, in fact, have to find a bargain price in order to be indifferent between living that close and living in a house described by the initial reference point. This situation might occur if the neighborhood of the place of employment were undesirable.

The preferred proportions approach involves changes of particular amounts, say any combination of decrease in price and decrease in distance up to a total of 15 units (in this case, a unit is either \$1,000 or 1 mile). This constraint restricts the allowable movement away from A_0 . Suppose that the most preferred new alternative that meets this constraint is A_2 (45, 8). This preference implies a

trade-off ratio of 10 miles for \$5,000. By checking a number of possible changes in distance from A_0 , we could trace out a curve of preferred proportions. The preferred proportions curve is, then, the locus of attribute values that the decision maker would prefer when moving away from the reference point in some series of constrained moves. The shape of the preferred proportions curve (the dashed line in Figure 5.4) exhibits the same preference rationale described above. It is level around A_0 , implying that the decision maker would make most changes to reduce distance. At about 8 miles the curve begins to drop off steeply, suggesting that the decision maker would not want to live much closer and hence would prefer to have a lower price rather than a shorter distance.

As might be expected, there is a direct relationship between the indifference approach and the preferred proportions approach. In considering infinitesimal changes from a given reference point, the indifference trade-off (called a marginal rate of substitution) is orthogonal to the preferred proportions trade-off (called a marginal rate of preferred proportions). However, increments of finite size from a given reference point will not, in general, be orthogonal. Similarly, the line linking two indifferent points, say A_0 and A_1 in Figure 5.4, is not likely to be the marginal rate of substitution at either point, nor is the line linking the reference point with a new preferred proportions point the marginal rate of preferred proportions at either point.

Another way to express the relationship between the two approaches is to relate them to a preference function $U(X, Y)$ on the attributes. An indifference curve is a contour of this function; that is, a locus of points of equal height or preference. A preferred proportions curve is a path up the preference surface under particular, allowable moves away from a given point.

By far the most commonly used trade-off is the indifference approach. It is particularly useful because it divides the set of all attribute values into (a) those indifferent to the reference point, (b) those preferred to the reference point, and (c) those to which the reference point is preferred. We know, then, that any point on the preferred side of the indifference curve is preferred to any point on the curve or on the nonpreferred side of the curve. Hence, if we are asked to compare A_0 with any other alternative, we can immediately indicate a choice. However, if we are given several points on the preferred side of the indifference curve, we cannot say which is the most preferred. It would be necessary to draw new indifference curves.

This situation is reversed in the preferred proportions approach. If the new alternatives given are on the preferred proportions curve, we can immediately order them in terms of preference. Compared to all possible alternatives, however, few would be expected to be on the curve. Therefore, if any two points are chosen at random, the probability of being able to make a preference judgment from a particular preferred proportions curve is close to zero.

From these comparisons we can conclude that if we start with a given alternative and can adjust the corresponding attribute values fairly readily, a curve of preferred

proportions could be useful. If, in contrast, we are trying to assess our preferences before confronting a set of alternatives from which we must choose, the curve of preferred proportions would be of less use.

5.3 CONSTRUCTIVE PROCEDURES FOR TRADE-OFF ANALYSIS

There are two basic modes for obtaining trade-offs from a decision maker: by inferring them from a series of successive choices he makes, or by having him state a trade-off value directly. Each of these modes can be used with either the indifference approach or the preferred proportions approach.

To use the successive choice mode with the indifference approach, we present the decision maker with a sequence of choices between pairs of alternatives. From a sufficient number of choices, we try to infer the decision maker's points (or zones) of indifference. When the choice situations are real, i.e., when the alternatives are actually realized by the decision maker, we would expect him to be highly motivated to reveal his true preferences. In the terminology of economics, an alternative A_0 is revealed preferred to alternative A' if A_0 is chosen when A' is also available. However, only in simple situations involving consumer choice do we begin to meet the requirements of the revealed preference methods. Generally, we can present the decision maker only with hypothetical choices. Although this limitation may affect the care with which he evaluates his preferences, it allows us to control the points that are presented for consideration. We can, for example, base our selection of alternatives on the decision maker's previous choices, and we can present those points that are likely to be the most informative. The successive choice mode, whether hypothetical or real, allows the decision maker to make relatively easy assessments (i.e., which of two points is preferred); hence this mode takes into account the limitations of human thought processes.

The use of the successive choice mode with the preferred proportions approach involves a similar procedure. Choices may be either real or hypothetical, and the successive choice mode assists in reducing the cognitive strain on the decision maker. The only difference is that, instead of comparing a new alternative with the reference point, we generate two new points and ask the decision maker which one he would prefer. From a sufficient number of such choices, we attempt to infer which points fall on the preferred proportions curve.

Using the direct mode with the indifference approach requires the decision maker to specify his preference equivalences directly; that is, we ask him to identify points that he considers to be indifferent to the reference point. Such judgments are difficult to make because there are an infinite number of points that can be considered and because making judgments about precise indifference points is a more complex task than that of judging strict preference. In other words, the direct mode requires the decision maker to perform the multiple operations of "generate and test" rather than the single operation of "test" required by the

successive choice mode. If the direct mode did yield points of true indifference, it would be more efficient than the successive choice mode; however, because the direct mode imposes a high degree of cognitive strain on the decision maker, it runs a high risk of yielding unreliable responses.

The same advantages and disadvantages apply when we use the direct mode with the preferred proportions approach. In this procedure, the decision maker states the point he most prefers, rather than a point indifferent to the reference point.

The ideal procedure for assessing a decision maker's trade-offs would offer the efficiency of the direct mode and the cognitive assistance of the successive choice mode. Furthermore, it would capture the motivational incentives found when the choices are actual rather than hypothetical.¹ In the remainder of this paper, we emphasize those methods that efficiently obtain trade-offs without taxing the cognitive abilities of the decision maker. Below, we first describe procedures for obtaining indifference curves and then procedures for obtaining preferred proportions curves.

5.3.1 INDIFFERENCE CURVES

An indifference curve through (X_0, Y_0) can be obtained in various ways. The methods differ primarily in the extent to which the decision maker must work unaided and the extent to which he is given help by the procedure and the analyst. When the decision maker receives no assistance, he is merely told to identify all the points he finds indifferent to (X_0, Y_0) . Generating and evaluating every possible point in the space of feasible attributes is clearly an onerous task. In contrast, the procedure and analyst may assist the decision maker by generating a series of points at random and asking him whether he prefers a particular point to (X_0, Y_0) , whether he prefers (X_0, Y_0) to the generated point, or whether he is indifferent. This method can, however, lead to great inefficiencies unless the new points are generated on the basis of the decision maker's preceding choices. Later in this section we consider random generation procedures, but here we focus on three types of structured procedures: (a) generating points by fixing only one attribute; (b) generating points by fixing both attributes, but fixing them one at a time; and (c) generating points by fixing both attributes simultaneously.

Indifference Curves Obtained by Fixing Only One Attribute

Cognitive strain experienced by the decision maker when he must consider changes from a reference point can be reduced by fixing the change in one of the attributes to a particular amount. Suppose, for example, that we want the decision maker to search for attribute values indifferent to (X_0, Y_0) . (For simplicity of discussion, we assume that there is a single point of indifference; the problem of the decision

¹We shall not go into the motivational problems here (see MacCrimmon and Toda, 1969, and Toda and MacCrimmon, 1972, for further discussion).

maker's inability to find a single point will be discussed later in this section.) We could fix X at, say, X_1 , and then ask the decision maker to find a Y value that will make (X_1, Y) indifferent to (X_0, Y_0) . Hence we are, in effect, identifying a line $X = X_1$ and asking the decision maker for a point of indifference on this line. This will be called the line procedure. As the preceding discussion indicates, either we can ask the decision maker to identify an indifferent point directly, or we can assist him by generating points for his consideration. If we were using the direct mode, we would ask: "What value of Y would result in indifference between (X_0, Y_0) and (X_1, Y) ?" If we were using the successive choice mode, we would ask: "Consider (X_0, Y_0) and (X_1, Y') ; which do you prefer, or are you indifferent? Now consider (X_0, Y_0) and (X_1, Y'') ; which do you prefer, or are you indifferent?" (The values Y' , Y'' , and so on are specific levels of Y used in presenting the choices.) We would present the decision maker with a series of such choices until he indicated his indifference between (X_0, Y_0) and one of the presented alternatives, call it (X_1, Y_1) .

For the remainder of section 5.3 we assume that the points of indifference sought in these procedures exist. This assumption will be relaxed in section 5.4.

Indifference Curves Obtained by Fixing One Attribute at a Time

By asking the decision maker to consider merely points along a single line, the line procedure reduces cognitive strain but its very simplicity may produce boredom and hence may cause the decision maker to give insufficient thought to his choices. This disadvantage suggests that the procedure be modified and extended. We could, for instance, fix both X and Y , but fix them one at a time; hence the decision maker would be asked to compare points along two lines. This may be thought of as a bending of the line $X = X_1$ at some point, say (X_1, Y_2) , to form a right angle in the line. (Let us choose Y_2 so that $Y_2 - Y_0 = X_0 - X_1$.) This concept is illustrated in Figure 5.5.

The right angle can be thought of as one corner of a rectangle or a square centered on (X_0, Y_0) . With this procedure, which we call the square procedure,¹ we can proceed just as we did in the line procedure. That is, we can use either direct questioning or successive choices among the set of points defined by the square to determine a point of indifference (X_2, Y_2) . Note that this is a different point from (X_1, Y_1) , although both points must lie on the same indifference curve (of course, it would have been the same point if $Y_1 \leq Y_2$).

The square procedure reduces the boredom effect by presenting different X and Y values. Because each new pair contains a particular X and Y value (namely, X_1 and Y_2), this procedure does not cause much increase in cognitive strain.

¹ Although a rectangle is more general, we can form a square by rescaling the attribute values. Since a square is a simpler figure, we adopt that form here. Other possible procedures (e.g., a cross procedure) could be given that would vary only one attribute at a time, but the square procedure appears to be the most efficient.

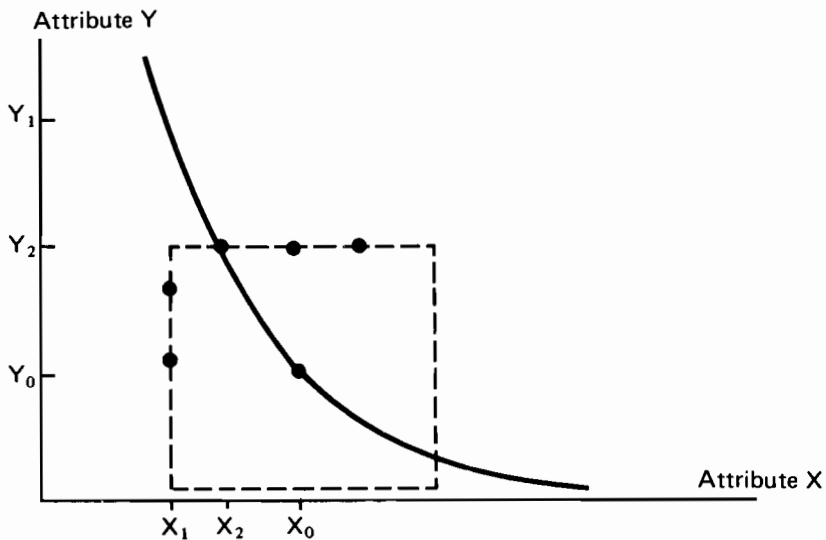

FIGURE 5.5 Square procedure for obtaining indifference curves

Indifference Curves Obtained by Fixing Both Attributes

The above procedure suggests that we might attempt to fix the values of both attributes simultaneously. This certainly tends to reduce boredom but increases the cognitive strain. Unlike the two preceding procedures, this one offers a large number of ways to define the sets of alternatives under consideration. We could, for example, define the sets of alternatives by using a diamond procedure or a circle procedure. The diamond procedure (Figure 5.6) was used implicitly in the house example given in section 5.2 (there, however, it was used to obtain the preferred proportions curve). A circle procedure (Figure 5.7) seems particularly appropriate here because it uses a Euclidean metric to measure the distance from (X_0, Y_0) . As discussed earlier, we could produce more general shapes (e.g., a parallelogram or an ellipse), but simpler figures are used to provide a better intuitive understanding.

Summary of Procedures for Obtaining Indifference Curves

In each of the above procedures, we considered only a single set of points; that is, we considered only one line, one square, one diamond, or one circle. If we want to obtain a relatively complete indifference curve, we must consider a number of structured sets of points. Hence, we would present multiple lines, squares, diamonds, or circles. To obtain a complete curve from the results of these sets of choices, we may have to interpolate among the choices or use the choices to estimate the parameters in fitting a curve of a particular functional form.

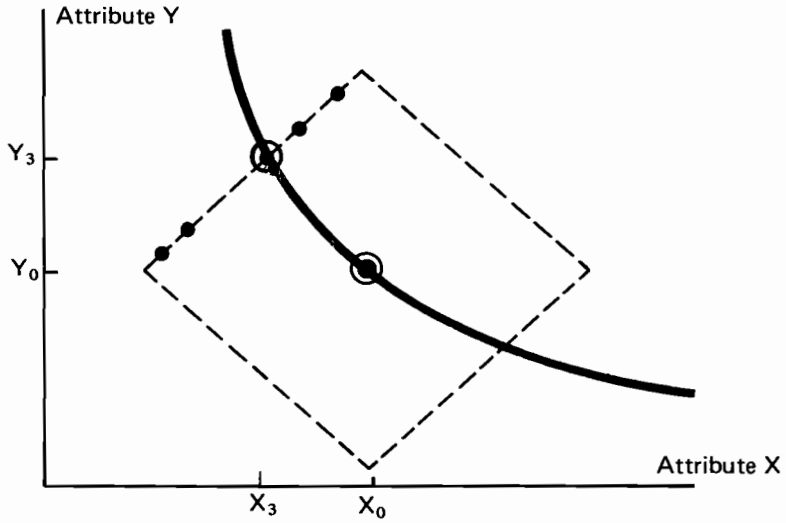

FIGURE 5.6 Diamond procedure for obtaining indifference curves.

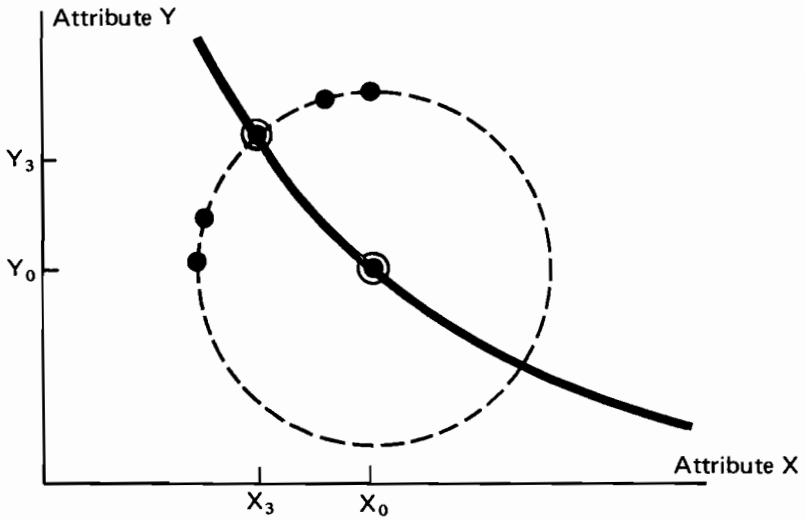

FIGURE 5.7 Circle procedure for obtaining indifference curves.

Some of the procedures we have described have been used by various researchers. The most common method is the line procedure with direct questioning. This has the virtue of simplicity but gives minimal aid to the decision maker. Geoffrion *et al.* (1972), as well as Dyer (1973) and Feinberg (1972), discuss a variety of methods, most of which are variants of the line procedure. They also use a procedure that fixes one attribute at a time, but, because it has lines through the reference point, it is not the same as the square procedure. MacCrimmon and Toda (1969) use an unstructured procedure with the successive choice mode. Since this procedure takes advantage of an assumption of monotonicity, we defer a discussion of it to section 5.4. MacCrimmon and Siu (1974) use the concentric circle procedure with successive choices. Thurstone (1931) uses a very inefficient procedure of asking the decision maker to make successive choices between the reference point and all points in the domain of interest.

5.3.2 PREFERRED PROPORTIONS CURVES

The techniques for presenting a decision maker with structured sets of alternatives to determine his preferred proportions of change are analogous to the techniques for determining the indifference curve. Thus, we may (a) fix only one attribute, (b) fix one attribute at a time, or (c) fix both attributes simultaneously. These techniques will lead, respectively, to the line, square, diamond, and circle procedures. There is, however, one main distinction between using these procedures to obtain an indifference curve and using them to obtain a curve of preferred proportions. In the indifference approach the reference point determines the points being generated and is also one of the alternatives in each of the choice pairs. In the preferred proportions approach, on the other hand, the reference point is not one of the alternatives in the choice pairs – it is used only as a basis for generating points to present to the decision maker.

Procedures for Obtaining Preferred Proportions Curves

Fixing one attribute, say X at X_1 , yields a set of points along a line. To obtain a preferred proportions curve we must determine which would be the decision maker's most preferred value of Y along this line if he could move to some place on the line from the current reference point.¹ In this approach, as in the indifference approach, the decision maker directly assesses his most preferred point on the line or an analyst assists him in this assessment by presenting him with successive choices. In Figure 5.8, the most preferred point on the line is circled; all the points have been compared with the others rather than with (X_0, Y_0) .

¹ If more of Y is always better, then the preferred point will have an infinite amount of Y . To facilitate representation of the curves, we assume that the most preferred point is at an intermediate value. The implications of nonmonotonicity assumptions will be covered in section 5.4.

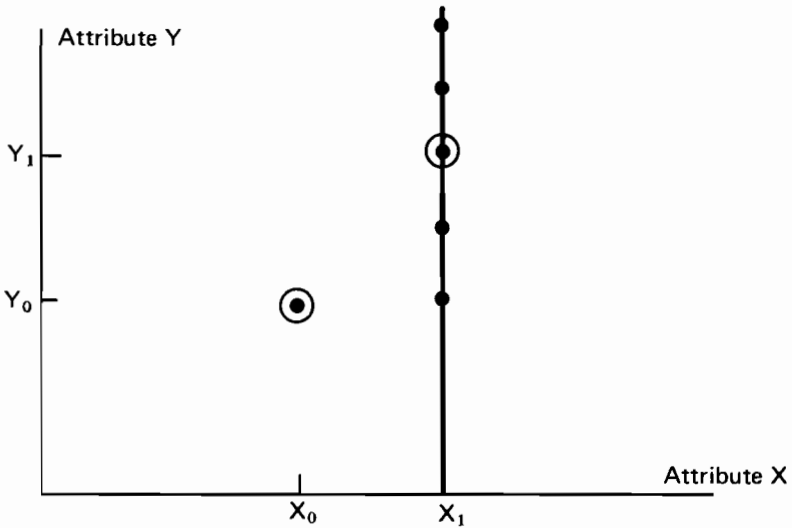

FIGURE 5.8 Line procedure for obtaining preferred proportions curves.

By following this approach for a number of different X values and obtaining a point of preferred proportions for each, we can trace out a curve of preferred proportions. The curve gives the path of points that the decision maker would most like to move along when starting from (X_0, Y_0) for fixed changes in X . This does not mean, however, that he would want to move out along the curve as far as possible.

Preferred proportions curves may be assessed by using procedures similar to those described for indifference curves, by fixing one attribute at a time through the use of the square procedure, or by fixing both attributes through the use of the diamond or circle procedure.

Summary of Procedures for Obtaining Preferred Proportions Curves

The procedures for obtaining preferred proportions curves can be used for any value of the incremental change. It seems reasonable to construct such a curve by beginning with a small increment, Δ , and by increasing it gradually. If a most preferred point in the entire attribute space is identified for some Δ , further increases in Δ may lead to less preferred points. Consequently, it is useful to compare the attribute values generated by successive values of Δ to determine whether there is a need to identify additional points on the preferred proportions curve. To obtain the complete preferred proportions curve we may use either interpolation or the fitting of a particular functional form.

Relatively little attention has been paid to developing curves of preferred proportion. MacCrimmon (1969) used a rotated line method in which the locus of preferred proportions is traced out on a line having a negative slope. This procedure was based on the use of budget curves in consumer choice. Geoffrion *et al.* (1972) suggest using preferred proportions curves but do not go into detail about how to construct them.

5.3.3 CONSIDERATIONS RELEVANT TO BOTH APPROACHES

We have assumed that the decision maker's preference discriminations are well specified. However, few people have precise indifference points or precise points of highest preference. Most people have a range of indifference or highest preference. This range would be represented as an indifference band or a preferred proportions band rather than as a single curve traced out through precise points. Sets of indifferent points having this property are called thick indifference curves; such curves will not be considered in detail in this paper.

There is a major difference between the procedures for constructing indifference curves and those for constructing preferred proportions curves. Whether an indifference curve is constructed by fixing only one attribute, one attribute at a time, or both attributes simultaneously, the same indifference curve results. When different procedures are used to construct a preferred proportions curve, however, different results may occur. For example, the use of the line procedure with a series of Δ may produce a different preferred proportions curve from that produced by using the square procedure. The reason for this is that the different procedures for constructing preferred proportions curves limit in different ways the changes from the reference point that the decision maker may consider. As long as one procedure is used consistently for constructing preferred proportions curves, no difficulty should arise.

With both the indifference approach and the preferred proportions approach, the application of procedures will yield a sequence of discrete points. To obtain a curve from these points, a somewhat arbitrary interpolation may be necessary. If the preference surface is highly irregular, the curves we may attempt to draw might bear little resemblance to the real preferences. Alternatively, if we were trying to fit a particular function, the functional form we used might be quite inappropriate.

The square, diamond, and circle procedures present the decision maker with a range of attribute values that completely circumscribes the reference point. Clearly, other procedures having this property are possible.

We could easily develop procedures in which the reference point was not a part of the final indifference or preferred proportions curve. For example, with the line procedure for indifference curves, suppose that a decision maker said he preferred a point (X_1, Y_5) to the reference point (X_0, Y_0) . Then, rather than selecting another Y value (say, Y_4) and asking him to compare (X_1, Y_4) and (X_0, Y_0) , we

could choose another X value, call this value X_5 , and ask him to compare (X_1, Y_5) with (X_5, Y_0) . If these were indifferent, then the indifference curve would go through these points and not through (X_0, Y_0) . This seems to be the procedure that Geoffrion *et al.* (1972) call the two-dimensional indifference curve procedure.

In the line procedures for obtaining indifference curves, the particular line chosen can serve as a numerical attribute for obtaining indifference curves over a number of attributes. This procedure is discussed by Raiffa (1969, section 4.2). Occasionally, it may be useful to set the line at $X = 0$ (or $Y = 0$) to find the value of the other attribute that would just compensate for an alternative yielding a zero value of X (or of Y). Raiffa (1969) utilizes this approach in a medical example with seven attributes.

Also relevant to both basic approaches is the procedure for generating successive choices. In general, we would want to use information at hand in generating points. If it is valid to assume additional properties for preferences, the problem of generating points can be somewhat simplified. When such assumptions are appropriate, even unstructured approaches can be quite efficient. The following section considers assumptions on preferences.

5.4 THE EFFECT OF ASSUMPTIONS ON PREFERENCE CURVES

A decision maker's preferences are generally assumed to satisfy the conditions of comparability and transitivity (continuity of preferences is a condition that can be assumed without operational difficulty). Comparability requires that the decision maker be able to compare any combination of attribute values. This assumption is quite reasonable, at least in a localized region such as the one surrounding the reference point. Transitivity implies that indifference curves do not cross. Violations of transitivity could lead to nonunique trade-offs as well. When decision makers are presented with their own intransitivities, they usually resolve them after further consideration. The decision maker's preferences are assumed to satisfy comparability and transitivity throughout this paper.

5.4.1 MONOTONICITY

Monotonicity Assumptions for Obtaining Indifference Curves

An additional, more restrictive, assumption can be made about the monotonicity of preference on attribute values. For each attribute, preference is assumed to be either always increasing or always decreasing for higher values of that attribute (monotonicity is defined only for attributes that are at least ordinally scaled). This assumption rules out the possibility that the decision maker would be totally satisfied or satiated with an intermediate level of an attribute. In the typical situation, we have two attributes, both of which are desirable, and for a given level of

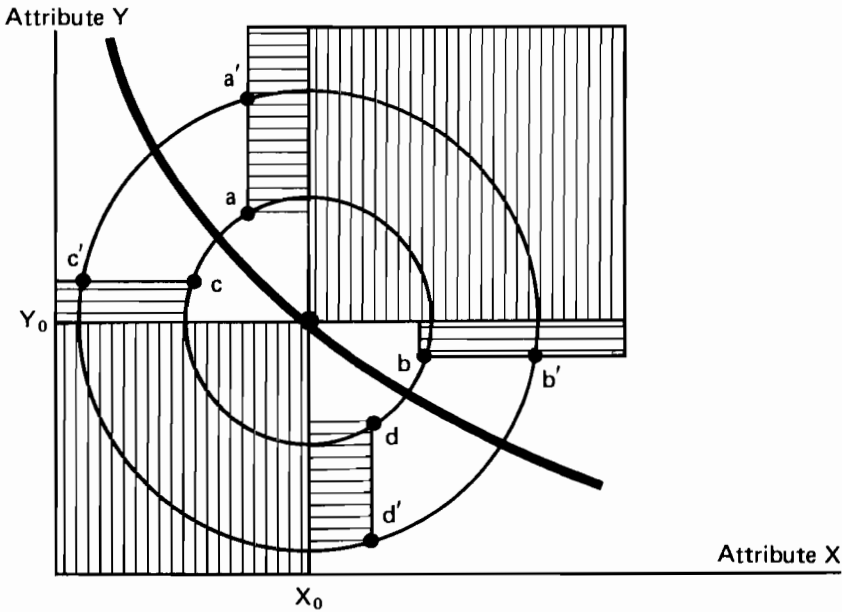

FIGURE 5.9 Circle procedure for obtaining indifference curves with two monotonic attributes.

one attribute we prefer as much as is obtainable of the other attribute. This yields the typical indifference curves, as shown in Figure 5.9.

When we know that preferences are monotonic, we can use the successive choice mode to minimize efficiently the number of points presented to the decision maker. For example, Figure 5.9 shows that, before we begin, we know that any point in the region above and to the right of the reference point is preferred to the reference point and any point in the region below and to the left of the reference point is not preferred. These regions are indicated by the vertical shading. If we are using the circle procedure and we find two points, a and b , that are both preferred to the reference point, we know that there cannot be an intermediate point on the arc between them that is not preferred. Furthermore, we know that when we consider a new circle, the points on the arc between a' (directly above a) and b' (directly to the right of b) must be preferred to the reference point. The corresponding argument holds for the nonpreferred points c and d (and hence c' and d').

When there is monotonicity on both attributes, the structured procedures have no particular advantage. Note that we could select any point in the unshaded regions of Figure 5.9, and, after determining whether it was preferred or not preferred, we could remove a large number of points from further consideration. The MacCrimmon–Toda procedure (1969) relies heavily on monotonicity and hence does not deal with a structured set of points such as a line or circle.

As long as the decision maker's preferences are monotonic in one of the attributes, the line procedure will be effective for any fixed value of another attribute. For example, if the decision maker always prefers more of attribute Y but has a satiation level for attribute X , the line procedure will generate a point indifferent to (X_0, Y_0) for any line $X = X_1$. Furthermore, the monotonicity assumption requires that the indifference curve not cross this line more than once. If the successive choice mode is used, monotonicity also allows portions of the line to be removed from the search for a point indifferent to (X_0, Y_0) . If point a is found to be preferred to (X_0, Y_0) , we know that any higher point on the line will be preferred, and if point b is found not to be preferred to (X_0, Y_0) , any lower point on the line will not be preferred. MacCrimmon and Toda (1969) also consider this procedure.

If a line is chosen for a fixed value of a monotonic attribute, difficulties may arise with the line procedure. For example, there may be no points indifferent to the reference point, or there may be several. If neither attribute is monotonic, the line procedure will generate a point of indifference only when the line is sufficiently close to the reference point and on the appropriate side of it.

In the circle procedure for indifference curves, monotonicity for at least one attribute guarantees the existence of two or more points of indifference. This holds for whatever radius is chosen for the circle. Moreover, if both attributes are monotonic, the decision maker can restrict his consideration to only two quadrants of the circle. For the attributes shown in Figure 5.7, only the upper-left and lower-right quadrants centered at the reference point need to be considered. When neither attribute is monotonic, Figure 5.10 shows that points of indifference need not exist unless the circle is sufficiently close to the reference point.

Monotonicity Assumptions for Obtaining Preferred Proportions Curves

As long as the decision maker's preferences are not monotonic in one of the attributes, the line procedure for preferred proportions curves will operate satisfactorily for any fixed value of the other attribute. In this case, a most preferred point on the line can be found. For example, if the decision maker's preferences are monotonic on attribute X and nonmonotonic on attribute Y (as in Figure 5.11), a most preferred point on the line $X = X_1$ can be found, namely (X_1, Y_1) . Because preference is monotonic on attribute X , (X_1, Y_0) must be preferred to (X_0, Y_0) . Since (X_1, Y_0) is on line $X = X_1$ and preferences are assumed to be transitive, it follows that the decision maker must prefer (X_1, Y_1) to (X_0, Y_0) . If both attributes are monotonic, a (finite) most preferred point on the line can be found only if the line is bounded. This can be done using the feasibility region for each attribute described earlier.

The circle procedure can always be used to find a most preferred point, even if the feasibility region is unbounded. This is because the circle is itself bounded. With this procedure, monotonicity of both attributes allows the decision maker to restrict his consideration to two quadrants of the circle.

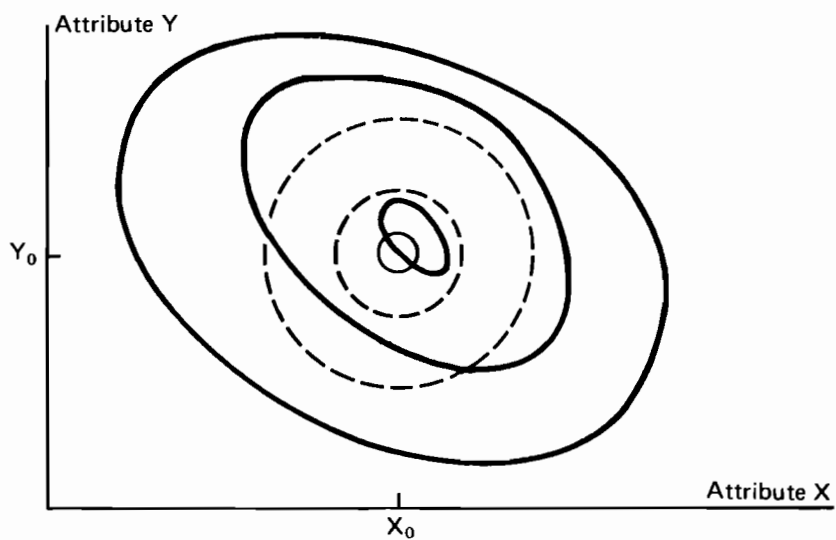

FIGURE 5.10 Circle procedure for obtaining indifference curves with both attributes nonmonotonic.

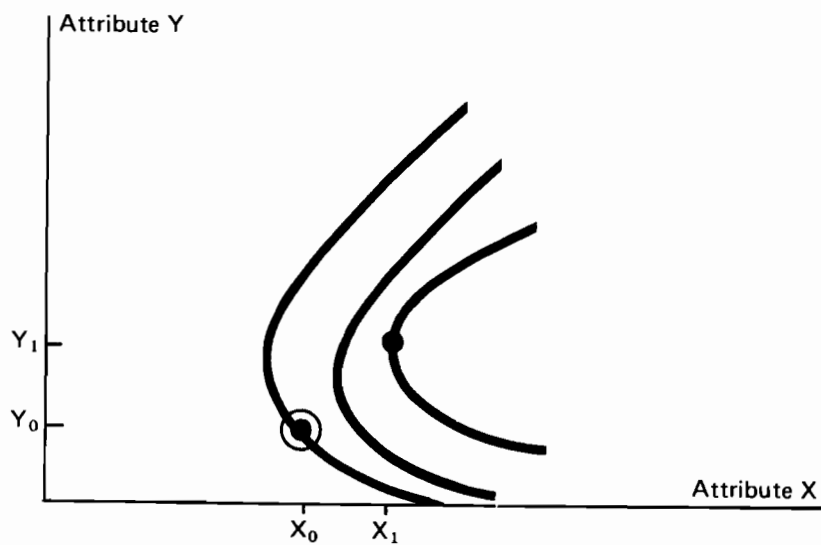

FIGURE 5.11 Line procedure for obtaining preferred proportions curve with one monotonic attribute.

Convexity Assumptions for Obtaining Indifference Curves

Another preference assumption that is often made is that of convexity of preferences. Preferences are called convex if the following condition holds for any two combinations of attribute values (X_1, Y_1) and (X_2, Y_2) . If the decision maker prefers the first to the second, or is indifferent in a choice between them, he must also prefer the new combination $(X_3, Y_3) = (0.5X_1 + 0.5X_2, 0.5Y_1 + 0.5Y_2)$ to (X_2, Y_2) , or be indifferent in a choice between them. One implication of convexity is that indifference curves cannot bend back on themselves.

The assumption of convexity guarantees that the search for a point of indifference or a most preferred point can be restricted to two quadrants centered at the reference point in the circle procedure. The use of the convexity assumption to obtain this advantage is beneficial only when at least one of the attributes is not monotonic (because the monotonicity of both attributes also leads to the same conclusion).

The principal benefit of the convexity assumption to trade-off analysis is that the marginal rate of substitution at a reference point (X_0, Y_0) can be used to identify a halfspace of (X, Y) values in which all points preferred to (X_0, Y_0) must lie. This property is especially useful when the decision maker is searching for a sequence of better points rather than identifying a single indifference curve. (In the rare situation where both attributes are so similar that there is an axis of symmetry for the decision maker's indifference curves, convexity guarantees that best points must be on this axis. If such a best point is desired, consideration can then be restricted to identifying the axis of symmetry and then searching along it.)

Thus far, we have discussed only individual properties for a decision maker's preferences. As mentioned in the subsection summaries of section 5.3, it is also possible to assume a parametric form for the indifference curves or preference function and then to estimate the appropriate unknown parameters. Trade-offs can then be calculated from the identified preferences. We would probably want to assume convexity of, at least, the indifference curve. This method will not be developed further here, but it should be clear that the procedures we describe could be used to obtain the data on which estimates of the parameters would be based.

5.5 *N* ATTRIBUTES: DIMENSIONALITY REDUCTION

When a decision problem has alternatives with only two attributes, we can use the techniques discussed in the preceding sections in one of two ways. We can either (a) select a best alternative from a set based on trade-off information in the form of indifference curves or (b) design a best alternative subject to particular constraints based on trade-off information in the form of preferred proportions curves. Few actual decisions, however, are confined to only two attributes. Hence,

if we wish to develop useful trade-off procedures, we must be able to deal with n attributes, where $n > 2$. In this section we examine a variety of ways to consider the n -attribute situation. The first methods will cover ways to deal with only two of the n attributes, or at least only two at a time. Subsequently, we examine ways to handle three or more attributes at a time.

5.5.1 N ATTRIBUTES: TRADE-OFFS ON NO MORE THAN TWO ATTRIBUTES AT A TIME

The simplest way to deal with trade-offs on n attributes is to ignore all but two attributes. This is not as ridiculous as it may sound. The cognitive limitations of decision makers force them to ignore information – not just irrelevant information. If two attributes could be carefully considered, with accompanying trade-offs, that might often be the best that could be expected. It would be preferable, of course, if the two attributes were the most important ones to the decision maker.

Lexicographic Trade-offs

By considering trade-offs on these two attributes, we have the elements of an extended lexicographic method. In the standard lexicography, the attributes are ordered by importance, and the alternative is chosen with the best value on the most important attribute. If there are two alternatives of equal value, the procedure is repeated for those alternatives on the next attribute, and so on until a unique alternative emerges (or until all attributes are considered). With the extended lexicography we consider here, we obtain the importance ranking in terms of classes of one or more attributes. If the most important class has more than one attribute, we form trade-offs among these attributes. The second most important class of attributes is considered only if there are several alternatives having equally preferred attribute values in the most important class.

This extended lexicography, then, has some of the simplifying aspects of standard lexicography and, in addition, overcomes the noncompensatory characteristic of the standard lexicography by considering trade-offs within a class. The standard method is an extended case of the extended method, i.e., when the classes considered have only a single attribute.

Hierarchical Combinations

The extended lexicographic method depends on forming equivalence classes based on importance or salience. Another type of classification that can facilitate the handling of n attributes is one based on the natural composition of particular attributes. The indifference curves that show the decision maker's trade-off between two attributes can be labeled to form an ordinal scale for a new composite attribute. If this procedure can be carried through for pairs of the remaining $n - 2$

attributes, we will have a new set of $n/2$ attributes. Similarly, if these composite attributes also have pairs of natural combinations we can consider the trade-offs among the pairs and use the indifference curves we obtain to scale a new higher-order composite attribute. We can continue this hierarchical combination until we obtain two high-order composite attributes for which we again form the trade-off. As a result, we will incorporate all the attributes.

To select the preferred alternative with this approach, we must be able to locate it in the final composite space. This can be done by assuring that each alternative is on an indifference curve in the initial spaces; thus, the combination of values defining an alternative will be one of the scale values for the new attribute. By including these combinations on an indifference curve each step of the way, we can ensure that the alternatives will be representable in the highest-order space we finally consider.

Note, then, that although this method considers only two attributes at a time, it includes all n attributes. This is in contrast to the extended lexicographic method, which ignores many of the attributes (assuming that there are not many alternatives of equal value in the early classes). This additional consideration, however, relies on a major assumption that may have been apparent to the reader. The use of this method requires that the attributes be independent among the initial classes. That is, while the trade-off between any initial pair can be nonconstant and highly interrelated, this trade-off cannot depend on the level of the other attributes. This restriction suggests that a useful way to form the initial pairs is by grouping attributes that seem relatively independent from the other ones. This notion is similar to the hierarchical format of Manheim and Hall (1968).

5.5.2 N ATTRIBUTES: TRADE-OFFS ON THREE ATTRIBUTES

Making trade-offs among three attributes is usually more difficult than making trade-offs between two attributes. To reduce cognitive strain on the decision maker, the assessment of trade-offs on three dimensions can be decomposed into a series of one- and two-dimensional assessments. This section presents these decomposed procedures as extensions of the line and square procedures; these are called cube procedures.

Indifference Surfaces in Three Dimensions

Suppose we wish to construct an indifference surface through the reference point (X_0, Y_0, Z_0) . The surface that surrounds this point will be a cube defined by adding or subtracting a positive amount Δ to or from each of these attribute values. If the Δ selected is sufficiently small, the indifference surface must cross at least one side of the cube. Depending upon the slope of the surface, it could cross from one to six sides of the cube. The indifference surface illustrated in Figure 5.12 crosses three sides.

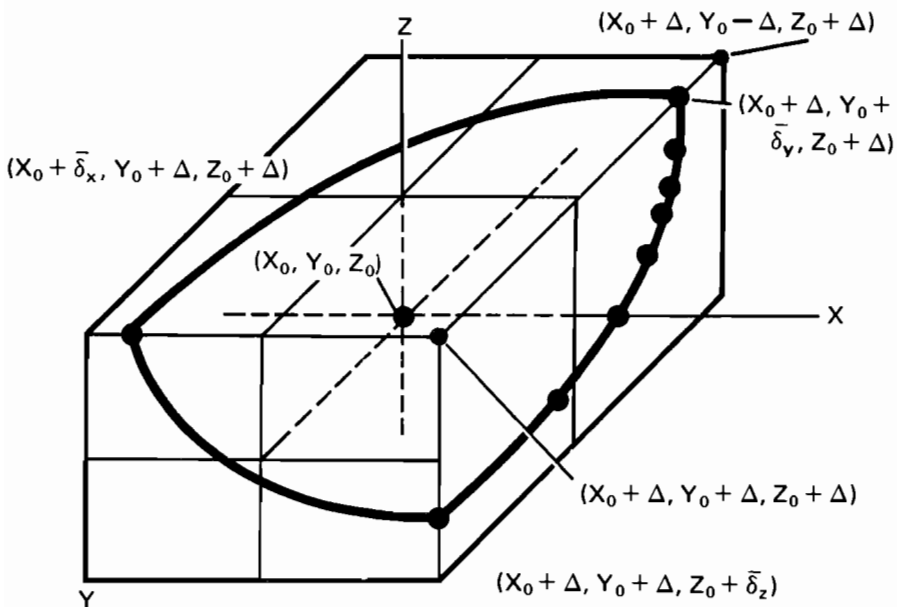

FIGURE 5.12 Indifference surface in three dimensions.

The analyst using the cube procedure begins by asking the decision maker to compare each of the cube's eight vertices with (X_0, Y_0, Z_0) . This comparison identifies regions of preference and nonpreference around the reference point. We assume that there is at least one edge of the cube for which one endpoint (vertex) is preferred to the reference point, which in turn is preferred to the other endpoint. (When none of the vertices is preferred to the reference point, some other preferred point on the cube must be identified and the procedure appropriately modified.) Let us suppose that this edge is given by $(X_0 + \Delta, Y_0 + \delta_y, Z_0 + \Delta)$, where $-\Delta \leq \delta_y \leq \Delta$, as in Figure 5.12. The point $(X_0 + \Delta, Y_0 + \Delta, Z_0 + \Delta)$ is preferred to the reference point, and the reference point, in turn, is preferred to $(X_0 + \Delta, Y_0 - \Delta, Z_0 + \Delta)$.

Because of the usual continuity properties assumed for indifference surfaces, there must be some point on this edge that is indifferent to the reference point (there could be a region of indifference if the indifference surface were thick). The procedure for finding such an indifferent point is similar to the line procedure for indifference curves in two dimensions. More specifically, a fixed increment, $\Delta > 0$, is added to the first and last attribute values of (X_0, Y_0, Z_0) and a scalar δ_y , $-\Delta \leq \delta_y \leq \Delta$, must be found such that $(X_0 + \Delta, Y_0 + \delta_y, Z_0 + \Delta)$ is indifferent to (X_0, Y_0, Z_0) . The only difference between this three-dimensional line procedure and the two-dimensional line procedure is that the former fixes two

attribute values, while the latter fixes only one. In Figure 5.12 the indifferent point is labeled $(X_0 + \Delta, Y_0 + \bar{\delta}_y, Z_0 + \Delta)$.

Having identified this point, we can now use any of the procedures defined earlier (line, square, diamond, circle) to determine a two-dimensional curve of points indifferent to (X_0, Y_0, Z_0) on a side of the cube. The point $(X_0 + \Delta, Y_0 + \bar{\delta}_y, Z_0 + \Delta)$ is on the side of the cube given by $(X_0 + \Delta, Y_0 + \delta_y, Z_0 + \delta_z)$, where $-\Delta \leq \delta_y \leq \Delta$ and $-\Delta \leq \delta_z \leq \Delta$.¹ We seek several points on this side indifferent to $(X_0 + \Delta, Y_0 + \bar{\delta}_y, Z_0 + \Delta)$ and hence also indifferent to the reference point. The line procedure used in Figure 5.12 constructs new lines on this side of the cube by temporarily fixing δ_z at some level. This procedure is nearly identical to the line procedure for indifference curves in two dimensions, except that the third attribute (X) is fixed (at $X_0 + \Delta$) throughout the procedure. The result of this line procedure is the indifference curve between $(X_0 + \Delta, Y_0 + \bar{\delta}_y, Z_0 + \Delta)$ and $(X_0 + \Delta, Y_0 + \Delta, Z_0 + \bar{\delta}_z)$. The line (or square, diamond, or circle) procedure can also be used to construct indifference curves on the sides of the cube given by $Y = Y_0 + \Delta$ and $Z = Z_0 + \Delta$. For example, in Figure 5.12 an indifference curve through $(X_0 + \Delta, Y_0 + \Delta, Z_0 + \bar{\delta}_z)$ can be generated on the side of the cube given by $Y = Y_0 + \Delta$.

Depending on the shape of the indifference surface, the cube procedure as described above will generate two-dimensional segments of the indifference surface through (X_0, Y_0, Z_0) on one or more sides of the cube. Using a cube defined by smaller or larger values of Δ will generate additional segments of the indifference surface. Such a procedure allows us to determine a three-dimensional indifference surface by making a series of trade-offs that are only one- or two-dimensional in nature.

Additional assumptions regarding the monotonicity and convexity of the decision maker's preferences simplify the cube procedure for indifference surfaces. For example, if the decision maker's preferences are monotonic on at least one attribute, the indifference surface must cross at least one side of the cube, regardless of the Δ chosen. When all the attributes are monotonic, at least one vertex of the cube must always be preferred to the reference point, and the reference point must always be preferred to at least one vertex. In Figure 5.12 all three attributes are monotonic, and these vertices are, respectively, $(X_0 + \Delta, Y_0 + \Delta, Z_0 + \Delta)$ and $(X_0 - \Delta, Y_0 - \Delta, Z_0 - \Delta)$ for any $\Delta > 0$. As a result, an edge of the cube can always be found for which one endpoint is preferred to the reference point, which, in turn, is preferred to the other endpoint. Furthermore, the assumption of convex preferences guarantees that only one point of indifference on this edge can be found via the line procedure for indifference surfaces in three dimensions.

The assumption of monotonicity on all three attributes also guarantees that the indifference surface must cross at least three sides of the cube. The vertex having values of each attribute higher than the reference point always determines three

¹ It is also on the side of the cube where Z is fixed at $Z_0 + \Delta$ and both X and Y can vary.

such sides. In Figure 5.12 these sides are determined by $X = X_0 + \Delta$, $Y = Y_0 + \Delta$, and $Z = Z_0 + \Delta$. Of course, the indifference surface might intersect more than three sides. This would be the case in Figure 5.12 if one or more of the vertices $(X_0 - \Delta, Y_0 + \Delta, Z_0 + \Delta)$, $(X_0 + \Delta, Y_0 - \Delta, Z_0 + \Delta)$, or $(X_0 + \Delta, Y_0 + \Delta, Z_0 - \Delta)$ were preferred to the reference point.

Use of the line procedure for indifference curves on a side of the cube can be simplified if the variable attribute is monotonic. In this case there must be a single point on each of the lines that is indifferent to the point on the edge of the cube. For example, in Figure 5.12 attributes X and Z are fixed at $X_0 + \Delta$ and $Z_0 + \delta_z$, respectively, and attribute Y is variable. The monotonicity of Y guarantees a single point indifferent to $(X_0 + \Delta, Y_0 + \bar{\delta}_y, Z_0 + \Delta)$ on each line and allows us to restrict our attention to only one segment of each line. This means that we need to consider only those alternatives having more than $Y_0 + \bar{\delta}_y$ of attribute Y .

Preferred Proportions Curves in Three Dimensions

The procedures for preferred proportions curves in three dimensions are similar to those for indifference curves.

REFERENCES

- Dyer, J.S. 1973. A time-sharing computer program for the solution of the multiple criteria problem. *Management Science*, Vol. 19, pp. 1379–1383.
- Feinberg, A. 1972. An experimental investigation of an interactive approach for multi-criterion optimization with an application to academic resource allocation. Working Paper 186. Western Management Science Institute, University of California, Los Angeles.
- Geoffrion, A., J.S. Dyer, and A. Feinberg. 1972. An interactive approach for multicriterion optimization with an application to the operation of an academic department. *Management Science*, Vol. 19, pp. 357–368.
- MacCrimmon, K.R. 1968. Decisionmaking among multiple-attribute alternatives: a survey and consolidated approach. RM-4823-ARPA. The Rand Corporation, Santa Monica, California.
- MacCrimmon, K.R. 1969. Improving the system design and evaluation process by the use of trade-off information: an application to the Northeast Corridor. RM-5877. The Rand Corporation, Santa Monica, California.
- MacCrimmon, K.R. 1973. An overview of multiple objective decision making. In *Multiple Criteria Decision Making* (J. Cochrane and M. Zeleny, eds.). University of South Carolina Press, Columbia, pp. 18–44.
- MacCrimmon, K.R., and J.K. Siu. 1974. Making trade-offs. *Decision Sciences*, Vol. 5, pp. 680–704.
- MacCrimmon, K.R., and M. Toda. 1969. The experimental determination of indifference curves. *The Review of Economic Studies*, Vol. 36, pp. 433–451.
- Manheim, M.L., and F.L. Hall. 1968. Abstract representation of goals. Working paper. Massachusetts Institute of Technology, Cambridge.
- Raiffa, H. 1969. Preferences for multi-attributed alternatives. RM-5868. The Rand Corporation, Santa Monica, California.
- Thurstone, L.L. 1931. The indifference function. *Journal of Social Psychology*, Vol. 2, pp. 139–167.
- Toda, M., and K.R. MacCrimmon. 1972. The determination of true preference equivalences. In *Contribution to Experimental Economics* (H. Sauermann, ed.). J.C.B. Mohr, Paul Siebeck, Germany, pp. 560–584.

6 Conjoint Measurement: A Brief Survey

R. Duncan Luce

6.1 INTRODUCTION

At its most general level, the purpose of conjoint measurement is to understand what sorts of numerical representations exist, if any, for orderings of Cartesian products of sets. The problem is ubiquitous:

1. In physics, one can order pairs consisting of a homogeneous substance and a volume by the mass of that volume of the substance – this can be done with a pan balance and a set of containers without having numerical measures of either mass or volume or, of course, substance. Presumably, if we understand matters correctly, we should end up with numerical measures of mass, volume, and density.

2. In economics, one can order commodity bundles – a listing of amounts of various goods – by preference. A numerical representation corresponding to preference would, on one hand, be a kind of utility measure and, on the other, tell something about how different commodities are aggregated by an individual.

3. In economics, statistics, and psychology, one can order gambles – consequences assigned to chance events – by riskiness and thereby arrive at a numerical scale of risk that shows how the consequences combine with the events to yield a measure of risk.

4. In psychology, one can present one intensity of a pure tone to one ear and a different intensity to the other ear, producing an overall sensation of loudness that is some composite of the loudnesses perceived by each ear separately. Given a subject's ordering by loudness of such pairs, we may study the existence of a numerical scale of loudness and of a law for combining loudnesses between the ears.

The problem is one of uncovering both scales of measurement of the factors and a law for combining these scales to form a composite or conjoint scale that

recovers the qualitative ordering. Often the problem is partially constrained by the existence of already known scales, derived in other ways, that should be related simply to those obtained by conjoint methods. For example, in physical measurement, we anticipate that the conjoint measures of mass and volume should relate simply to the usual measures derived from the theory of extensive measurement, which is based on the existence of an operation of combination that preserves the attribute in question. Such “concatenation” operations are typified by placing two masses together on a pan balance or by abutting two rods to form a new rod.

We shall confine our attention to one particularly simple class of numerical representations. Let A and P be sets and \succsim a binary relation on $A \times P$. We say that the structure $\langle A \times P, \succsim \rangle$ is *decomposable* if and only if there exist functions ϕ_A on A and ϕ_P on P into the real numbers and a function F from the real plane into the reals such that $F(\phi_A, \phi_P)$ represents \succsim . To be specific, for all a, b in A and p, q in P ,

$$(a, p) \succsim (b, q) \text{ iff } F[\phi_A(a), \phi_P(p)] \geq F[\phi_A(b), \phi_P(q)].$$

Another way to describe this is to say that there is a binary operation \odot on the reals such that $\phi_A \odot \phi_P$ represents \succsim , where, of course, for all real r and s , the following relation between \odot and F holds:

$$r \odot s = F(r, s).$$

Our attention will be restricted to the decomposable case and the obvious generalization of that concept for three or more factors.

Although this sort of representation seems incredibly general – certainly it appears to cover all of the two-factor cases one runs into in physics – there are simple, and perhaps interesting, cases not covered by it. For example, suppose ϕ_A, ψ_A , and ϕ_P, ψ_P are functions on A and P , respectively, and \succsim is the ordering generated on $A \times P$ by

$$\phi_A + \phi_P + \psi_A \psi_P;$$

then, except for a few special cases, $\langle A \times P, \succsim \rangle$ is not a decomposable structure. Nevertheless, this representation seems interesting because the interaction term that is added to the additive part of a representation is itself multiplicatively independent. The only relevant work (Fishburn, 1975) makes it clear that it will probably be difficult to understand what properties of \succsim lead to such a representation.

When one already has measures of either the two factors A and P or of one of those and of \succsim on $A \times P$ – this is true of examples 1, 2, and 4 above – then one can represent the information given in the problem by means of *indifference curves*. In the physical example, we have measures of mass and of volume, so we identify with each substance the locus of mass–volume pairs that can arise. Each substance will generate its own curve, and under reasonable assumptions these will not intersect. In the psychological example, we have physical measures of the

intensities presented to the two ears (usually we use the logarithm of intensities — the decibel scale), and we plot the loci of intensity pairs that are judged to produce equivalent loudness. The problem in these cases is to find a suitable numerical representation of the indifference curves.

The question becomes one of deciding on what we mean by a suitable representation. It appears that the only formal requirement for acceptance of the result as a form of measurement is that the representation be nearly unique. Often the degree of uniqueness is described in terms of the group (or semigroup) of transformations that take a representation involving \odot into another representation based on the same \odot . For example, in the usual theory of mass measurement, the concatenation operation is mapped into $+$ and \succ is mapped into \geq , and it is shown that only multiplication by a positive constant takes one representation into another representation. This corresponds to a change in units. However, when \odot is more complex than $+$ or \cdot , explicitly describing the class of admissible transformations can be difficult. It seems better simply to say how many values of the representation must be specified in order to determine it uniquely. In the case of mass, one value is sufficient. Thus, our interest will be in constructing representations that become unique when their values are specified at one or a few points.

The rest of the paper deals with most of what is known about decomposable representations. First, both historically and in terms of mathematical simplicity, is the additive case: when \odot is $+$. This is the most fully understood case and in many ways serves as an underpinning to more general ones. Second, we look at several results of a nonadditive sort. Third, we examine the problem of relating conjoint structures to concatenation structures and the way in which this provides some better understanding of the interplay of addition and multiplication, which is exploited in dimensional analysis. Finally, we look at the, as yet, small literature concerned with random variable representations of conjoint structures.

My main concern is with the key ideas and the general spirit, and so I shall slight various points of mathematical nicety. The interested reader will find the precise definitions and theorems in the references cited.

6.2 THE ADDITIVE REPRESENTATION

6.2.1 THE INFINITE CASE

Ideally, one would like to know two things: what are necessary and sufficient conditions for $\langle A \times P, \succ \rangle$ to have an additive representation, and how does one construct the functions ϕ_A and ϕ_P ? We cannot yet answer either question fully. When A and P are finite sets, necessary and sufficient conditions are known (see section 6.2.2, below), and the representation, whose uniqueness is very difficult to characterize, involves finding the solutions to a system of linear inequalities. Algorithms for doing this are known and, because of the speed of computers, are

feasible if the sets are not too large. In the infinite case, we know only sufficient conditions for the existence of an additive representation, but we have systematic procedures to approximate ϕ_A and ϕ_P , and they are unique up to specification at two points. We take up the infinite case first.

The axioms are conveniently grouped into three types:

First-order axioms: necessary conditions. These include at least the following three properties, each of which derives immediately from the intended representation by cancellations in the corresponding linear inequalities.

Transitivity: if $(a, p) \succ (b, q)$ and $(b, q) \succ (c, r)$, then $(a, p) \succ (c, r)$.

Independence: if $(a, p) \succ (b, p)$, then $(a, q) \succ (b, q)$; if $(a, p) \succ (a, q)$, then $(b, p) \succ (b, q)$.

Double cancellation¹: if $(a, x) \succ (f, q)$ and $(f, p) \succ (b, x)$, then $(a, p) \succ (b, q)$.

First-order axioms: structural conditions. These are not necessary consequences of this representation; rather, they constrain the structures in ways that are thought to be useful. Various requirements of nontrivialness are of this sort. Of more substantive interest are axioms that assume the existence of elements where one wants them. If \sim is defined as above, the strongest form of *solvability* says that one can always construct a complete indifference curve passing through any prescribed point. That is, given a, b in A and p in P , there exists q in P such that $(b, q) \sim (a, p)$. Similarly, given a in A and p, q in P , there exists b in A such that $(b, q) \sim (a, p)$. As this is restrictive in many cases, a weaker form of solvability, called *restricted solvability*, is usually invoked: it says, for the first component, that if there are \bar{b} and b in A such that $(\bar{b}, q) \succ (a, p) \succ (b, q)$, then b exists in A such that $(b, q) \sim (a, p)$. A similar statement holds for the second component.

The primary role played by these solvability conditions is to ensure the existence of what amounts to equally spaced elements. The method of finding such a sequence in one coordinate is to balance them off against a pair of elements in the other coordinate. Thus, we say that a sequence a_i in A , where i is in a set I of successive integers, is a *standard sequence* if there are p, q in P such that for all $i, i + 1$ in I ,

$$(a_i, p) \sim (a_{i+1}, q).$$

We see that if an additive representation exists, then

$$\phi_A(a_i) - \phi_A(a_{i+1}) = \phi_P(q) - \phi_P(p),$$

and so the successive intervals of the standard sequences are, indeed, equal. Without solvability, there is no reason for any standard sequences to exist. With solvability,

¹ If $(a, p) \sim (b, q)$ is defined to mean $(a, p) \succ (b, q)$ and $(b, q) \succ (a, p)$, then double cancellation for \sim is called the Thomson condition.

even restricted solvability, some do exist, and they play a vital role in the construction of the representation.

Second-order axioms. The third kind of axiom is again a necessary condition, but it is a second-order axiom in the sense of logic. The one usually invoked is called an Archimedean axiom.¹ It simply states that any standard sequence that is bounded from above and below is finite. Such second-order axioms are infuriating to the empirical scientist because they cannot be tested directly. For this reason, it is reassuring to know that the Archimedean axiom is dispensable, provided one is willing to accept representations into the nonstandard reals (Narens, 1974a; Skala, 1975). Put another way, $(a, p) \succ (b, q)$ maps into $\phi_A(a) + \phi_P(p) \geq \phi_A(b) + \phi_P(q)$ (\succ goes into \geq , rather than into $>$).

The major theorems in the infinite case invoke a mix of first-order necessary and structural axioms, together with the Archimedean axiom, to prove the existence of functions ϕ_A on A and ϕ_P on P such that $\phi_A + \phi_P$ is order-preserving. Moreover, if ϕ'_A, ϕ'_P is another representation, then there are constants $\alpha > 0, \beta_A$, and β_P such that $\phi'_A = \alpha\phi_A + \beta_A, \phi'_P = \alpha\phi_P + \beta_P$.

There is a distinct trade-off between the strength of the necessary axioms one needs to invoke and the strength of the structural conditions. For example, Luce and Tukey (1964) and Debreu (1960), who used strong topological assumptions, invoked weak ordering (transitivity plus connectedness of \succ), double cancellation, nontrivialness, and solvability. Later, following work of Holman (1971) and Luce (1966), Krantz *et al.* (1971) used weak ordering, independence, Thomson condition, non-trivialness, and restricted solvability. The trade-off involves weakening solvability to restricted solvability and compensating by replacing double cancellation with the weaker Thomson condition together with the property of independence. Both systems also invoke the Archimedean property.

The method of proof is of some interest. Independence means that \succ induces a unique weak order on each component; e.g., \succ_A is defined by $a \succ_A b$ iff $(a, p) \succ (b, p)$ for some p in P , and \succ_P is defined similarly. Fix a_0 and p_0 . By solvability, define the function π by $(a_0, \pi(a)) \sim (a, p_0)$, and by solvability define the operation \circ_A on A as the solution to

$$(a \circ_A b, p_0) \sim [a, \pi(b)].$$

In this construction, a_0 acts like a zero element because $\pi(a_0) \sim_P p_0$ and

$$(a \circ_A a_0, p_0) \sim (a, \pi(a_0)) \sim (a, p_0),$$

whence $a \circ_A a_0 \sim_A a$. It turns out that the set of elements A_0 of A that are $\succ_A a_0$ and the restriction of \circ_A and \succ_A to that set behave mathematically just like

¹ In some axiomatizations, the Archimedean axiom and the solvability condition are combined into a somewhat stronger topological axiom called completeness. See Ramsey (1975) for a defense of this and Narens and Luce (1975) for an objection to it. In other axiomatizations the existence of a countable order-dense subset is postulated.

length or mass, and the theory of extensive measurement (see Krantz *et al.*, 1971, Chapters 2 and 3) ensures the existence of ϕ_A that is additive over \circ_A . This function is easily extended to the elements $\lesssim a_0$. The methods for approximating it in terms of a standard sequence are well known. In particular, if a standard sequence a_i , beginning with a_0 , is constructed relative to p_0 and $p_1 (> p_0)$, then we can choose ϕ_A so that $\phi_A(a_i) = i$. For any $a > a_0$, and any n , find $i(n)$ such that

$$a_{i(n)} > na \lesssim a_{i(n)-1},$$

which is possible according to the Archimedean axiom. Thus,

$$\frac{i(n)}{n} > \phi_A(n) \geq \frac{i(n)-1}{n},$$

and so, to within an error of $1/n$, $\phi_A(a) = i(n)/n$. This means that the construction of the conjoint representation is feasible via standard sequences.

The function ϕ_P can be constructed similarly; however, it is easier merely to define it as

$$\phi_P(p) = \phi_A \pi^{-1}(p).$$

Thus the problem is reduced to proving that $\phi_A + \phi_P$ is order-preserving.

Additive conjoint measurement on three or more factors is a bit simpler. Independence is generalized to mean that the ordering induced on any set of factors is independent of the common value selected for the complementary factors. No analog of double cancellation or Thomson condition is needed because, in the presence of the other axioms, these conditions can be derived for any pair of factors. So, when there are three or more factors, an additive representation exists if the following conditions hold: weak ordering, independence, restricted solvability, nontrivialness, and an Archimedean property.

Another approach, not involving solvability conditions but invoking many cancellation properties, which extends techniques from the finite case to the infinite one, can be found in Jaffray (1974).

6.2.2 THE FINITE CASE

Data developed using standard sequence techniques are rather more special than an ordering of an arbitrary finite $A \times P$, which arises when one runs a straightforward factorial design. In the latter case, no solvability properties whatever will be satisfied, and so all one has to work with are the first-order necessary conditions. These include the ones we have listed and any others that can be derived from linear inequalities by canceling common terms. One might hope that a finite set of such inequalities would suffice, but Scott and Suppes (1958) proved that to be impossible. The number of inequalities necessary and sufficient for an additive representation increases with the number of elements in $A \times P$. Scott (1964) and Tversky (1964) independently devised a compact way of formulating these

necessary and sufficient conditions (see Krantz *et al.*, 1971, Chapter 9). This type of condition has been generalized to countable and noncountable situations by Jaffray (1974).

In practice, one simply writes down for each data inequality the corresponding numerical linear inequality and then searches for a solution to the resulting system. Computer programs for doing this have been developed by Tversky and Zivian (1966) and Young (1973), among others.

Narens (1974b) raised the question of when a nested collection of finite additive conjoint structures approaches a countable additive conjoint structure whose representation is unique up to interval scales. To get at this, let \succsim be an independent weak ordering of $A \times P$. On A , define

$a - b \succ_A c - d$ iff there exist p, q in P such that $(a, p) \succ (b, q)$ and $(c, q) \succ (d, p)$.

In terms of this notion, for $b \succ_A a$ we say c, d in A form a *trisplit* if

$$b \succ_A d \succ_A c \succ_A a, b - c \succ_A c - a, d - a \succ_A b - d, b - c \succ_A d - c, \\ \text{and } c - a \succ_A d - c.$$

If for each pair of elements from each component there is a trisplit, then we say the conjoint structure is *trisplittable*. Narens shows that if each member of the nested set is trisplittable, then the above convergence obtains.

6.2.3 FUNCTIONAL MEASUREMENT

Anderson and his associates have published extensively on functional measurement, which is, in many ways, closely related to conjoint measurement (see Anderson, 1970, 1971, and 1974, for surveys and bibliographies). There are two key features of Anderson's work. First, the data take the form of numbers, usually arising from some sort of rating or category method: for example, if the stimulus (a, p) consists of sound intensities to the two ears, the subject provides a loudness rating that fits into, say, one of seven categories. Second, the data (or, in some cases, some transformation of them) are assumed to satisfy some explicit representation. One case is the additive representation just discussed, but much more important in Anderson's work have been representations of weighted averages. If I understand him correctly, these representations are axiomatized by the bisymmetric operations of section 6.4.1, below.

Various techniques, closely allied to analysis of variance methods, are used to obtain the scales from the category ratings. These methods have been applied to a wide range of situations, from psychophysics to impressions of personality obtained from verbal descriptions.

Anderson makes much of the internal consistency he finds when these representations are coupled with category scaling, and he criticizes (Anderson, 1970) another method initiated by Stevens (1957, 1975) and widely used in psychophysics. Stevens' magnitude estimation differs from the category methods in that

the range of possible numerical response is not limited and the subject is asked to use the numbers so that they reflect the subjective ratios of stimuli. On the face of it, one would not expect the additive or averaging models to be appropriate to these instructions, but certain multiplicative representations might be. Because magnitude methods are very easy to use and, at least in psychophysics, are widely useful and their detailed properties are becoming better understood (Green and Luce, 1974; Marks, 1974; Moskowitz *et al.*, 1974; Stevens, 1971, 1975), they probably should be given serious consideration by students of factorial situations.

Both the category and magnitude methods have, for factorial designs, the advantage over the ordering methods in that they provide a numerical scale without requiring the solution of systems of linear inequalities. All these methods, of course, have the disadvantage, compared with studying axioms individually, of not localizing the difficulty when the model fails to fit the data.

A great deal of controversy exists over the relationship between functional and conjoint measurement – see, for example, the criticism of Anderson (1971) by Hodges (1973) and Schönemann *et al.* (1973), with a reply by Anderson (1973). Roughly, the lines are drawn as follows. Measurement theorists point out that no qualitative representation theorems are proved in the functional measurement literature, to which the reply is “What good are such theorems?” The answer is, first, that direct tests of axioms appear to be more revealing of the failure of a representation than is fitting it to factorial data, and, second, that the proofs of the theorems suggest ways to construct representations in nonfactorial situations. Anderson (1974) points out that his empirical methods go far beyond anything found in the conjoint measurement literature. They suggest a substantive hypothesis that, if true, is important; this hypothesis holds that particular data collection procedures yield the representation directly without further transformation and that techniques of the analysis of variance can be employed to cope with error. Moreover, he and his colleagues have collected far more data than all the measurement theorists put together, and these data do not support the additive representation that has been so much the focus of conjoint measurement. The measurement theorists have had little to say in reply, although they have informally criticized specific studies (complaining, for example, that the dynamic ranges used in the psychophysical studies are too narrow to test his methods rigorously). In my view, the methods are largely complementary, not competitive.

6.2.4 UNIFORM SYSTEMS AND INDIFFERENCE CURVES

In the special, but important, case when there are numerical measures (often physical, but not always) on A and P that agree with \succ_A and \succ_P , respectively, the problem can be recast in terms of indifference curves in the plane. In fact, the additive case is equivalent to finding transformations of the two given scales so that the indifference curves become straight lines with slopes -1 . When one has all possible indifference curves in the plane, the theory of webs provides the

solution (Blaschke and Bol, 1938; Aczél *et al.*, 1960; Havel, 1966; Radó, 1960, 1965). However, in practice, one usually has only a finite amount of information about each of a finite number of curves. By reasonable interpolation, one can replace this situation by a situation in which one knows a finite number of indifference curves completely. Note that this situation is not exactly like the infinite one, where one develops standard sequences, and it is certainly different from the finite factorial one. Levine (1970, 1972) has studied such systems and generalizations of them; some of his results are summarized by Krantz *et al.* (1971, section 6.7). Roughly, one constructs from any two given indifference curves F and G another curve of the form $F^{-1}G$, and these curves can be transformed into the additive form if and only if none of the original curves nor any generated recursively by forming $F^{-1}G$ intersect.

Levine (1975a, b) has been developing computer methods, based heavily on the group theoretic character of his theorems, to make the search for additive (and other) representations practical. He is applying these techniques to latent trace models for test theory.

6.3 NONADDITIVE REPRESENTATIONS

Since even the additive case is far from fully understood, we can anticipate only partial results in nonadditive cases. Again, we must distinguish between the infinite and finite situations. As the results in the finite case are quite abstract (see section 9.5 of Krantz *et al.*, 1971), and since they have not, to my knowledge, been applied, I will not summarize them. So we deal with the infinite case.

Recall that a structure of the form $\langle \times_{i=1}^n A_i, \succ \rangle$ is *decomposable* if and only if there are real-valued mappings ϕ_i on A_i and a real-valued function F of n variables such that

$$(a_1, \dots, a_n) \succ (b_1, \dots, b_n) \text{ iff } F[\phi_1(a_1), \dots, \phi_n(a_n)] \succ F[\phi_1(b_1), \dots, \phi_n(b_n)].$$

It is *monotonically decomposable* if, in addition, F is strictly monotonic in each of its arguments. Krantz *et al.* (1971, section 7.2) give necessary and sufficient conditions for the existence of such a monotonically decomposable representation: \succ must be a weak ordering, the equivalence classes of $A = \times_{i=1}^n A_i$ under \succ must have a countable order-dense subset (i.e., a countable set B such that between any two distinct elements of A there is an element from B), and each A_i must be independent of the remaining components in the sense that for each i

$$(a_1, \dots, a_{i-1}, a, a_{i+1}, \dots, a_n) \succ (a_1, \dots, a_{i-1}, b, a_{i+1}, \dots, a_n)$$

if and only if

$$(b_1, \dots, b_{i-1}, a, b_{i+1}, \dots, b_n) \succ (b_1, \dots, b_{i-1}, b, b_{i+1}, \dots, b_n).$$

Expressed verbally, the ordering established on A_i is independent of the fixed choices on the remaining components.

This result is less than satisfactory in two ways. It involves an awkward second-order axiom, namely, the existence of a countable order-dense subset, and it provides no insight into constructing the representation. For the case of two components, Narens and Luce (1975) drop the countability requirement, and they show how to reduce the construction of the representation to that of a non-associative concatenation structure. Moreover, they work with a local (not connected) ordering, which is sometimes useful. In the special case of a weak ordering, their axioms are essentially those of the additive case, minus the Thomson condition plus density: weak ordering, independence, nontrivialness, solvability, density, and an Archimedean property. Using the same definition of \circ_A as in the additive case, they show that $\langle A, \succ_A, \circ_A \rangle$ is a positive concatenation structure that is associative only if the Thomson condition holds. Thus, the problem of constructing the representation is reduced to that of constructing one for the operation \circ_A . This is by no means generally understood.

More specialized results of Krantz (1968), Krantz and Tversky (1971) (summarized in sections 7.3–7.4 of Krantz *et al.*, 1971), and Falmagne (1973) hold for simple polynomial representations. A simple polynomial is defined inductively as one for which the variables can be partitioned into two sets such that the given polynomial is either the sum or the product of simple polynomials on the two sets. For example, $(\phi_1 + \phi_2)\phi_3\phi_4$ is simple, but $\phi_1\phi_2 + \phi_2\phi_3 + \phi_1\phi_3$ is not. One can, in the presence of solvability conditions, work out necessary properties that permit distinction among these cases. These properties, which are too complex to state here, permit one to search for additivity, $\phi_1 + \phi_2$; multiplicativity, $\phi_1\phi_2$; and various types of cancellation properties that arise from the distributive property $\phi_1(\phi_2 + \phi_3) = \phi_1\phi_2 + \phi_1\phi_3$. The models have been worked out in detail for $n = 3$, where the four simple polynomials are

$$\phi_1 + \phi_2 + \phi_3, \phi_1\phi_2\phi_3, \phi_1(\phi_2 + \phi_3), \text{ and } \phi_1\phi_2 + \phi_3,$$

plus permutations on the indices of the last two. Some applications of these methods are described below.

A general discussion of polynomial measurement in the finite case is given by Tversky (1967a) (see section 9.5 of Krantz *et al.*, 1971); Richter (1975) has resolved a conjecture on the conditions under which systems of polynomial inequalities have a solution.

6.4 RELATIONS TO OTHER FORMS OF MEASUREMENT

Conjoint measurement has proved more useful at a theoretical level than at an empirical one. It is not that we lack empirical applications — see section 6.5 — but that applications of conjoint measurement to theoretical problems have provided deeper insight than have the empirical applications. Three applications are described

in this section, and another has been described in the preceding section – namely, a fairly general case where conjoint structures reduce to nonassociative positive concatenation structures; our first example below is its converse.

6.4.1 CONCATENATION STRUCTURES

Classical physics exhibits two quite different kinds of binary operations – *extensive* ones, such as juxtaposition of rods for length or set theoretic union for mass; and *intensive* ones, such as temperature and density. The former are *positive* in the sense that $a \circ b \succ a, b$ and also associative, whereas the latter are *intern* in the sense that if $a \succ b$, then $a \succ a \circ b \succ b$. If we drop all three special properties, we have what are called *concatenation structures*.

Assume that the structure $\langle A, \succ, \circ \rangle$ satisfies the following properties:

\succ is a nontrivial weak order; i.e., for some a, b in A , $a \succ b$.

Monotonicity: $a \succ b$ iff $a \circ c \succ b \circ c$ iff $c \circ a \succ c \circ b$.

Restricted solvability: if $\bar{b} \circ c \succ a \succ b \circ c$, then there are b in A such that $b \circ c \sim a$ (the parallel statement on the right is also true).

Archimedean property: let standard sequence a_i satisfy $a_i \circ p \sim a_{i+1} \circ q$ or $p \circ a_i \sim q \circ a_{i+1}$ for some p and q , then every bounded standard sequence is finite.

If \succ' on $A \times A$ is defined by

$$(a, b) \succ' (c, d) \text{ iff } a \circ b \succ c \circ d,$$

then it can be shown (see Krantz *et al.*, 1971, section 6.101) that the conjoint structure $\langle A \times A, \succ' \rangle$ satisfies the requirements for weak ordering, independence, restricted solvability, the Archimedean property, and nontrivialness. Moreover, if we add the important property of bisymmetry,

$$(a \circ b) \circ (c \circ d) \sim (a \circ c) \circ (b \circ d),$$

then \succ' satisfies double cancellation. In the latter case, we can use the additive conjoint representation and prove there is an order-preserving representation ϕ and constants $\mu \succ 0, \nu \succ 0, \lambda$ such that

$$\phi(a \circ b) = \mu\phi(a) + \nu\phi(b) + \lambda.$$

Additional properties on \circ place restrictions on the constants:

If $a \circ a \sim a$, as in the intensive case, $\mu + \nu = 1$ and $\lambda = 0$.

If \circ is commutative, i.e., $a \circ b \sim b \circ a$, then $\mu = \nu$.

If \circ is associative and commutative, as in the extensive case, $\mu = \nu = 1$ and, with no loss of generality, $\lambda = 0$.

Narens and Luce (1975) have shown that there is a complementary relation between one general class of intensive structures and nonassociative, positive concatenation structures with half elements.

6.4.2 CONDITIONAL EXPECTED UTILITY

In an attempt to overcome some of the criticisms of Savage's (1954) important axiomatization of subjective expected utility, Luce and Krantz (1971) (see Krantz *et al.*, 1971, Chapter 8) axiomatized a notion of conditional decisions. One may think of their formulation as based on an algebra \mathcal{E} of events, a family \mathcal{D} of conditional decisions that can be written f_A , where A is in \mathcal{E} (this suggests that f_A is a function from A into some set of consequences, which is one interpretation of the model), and an ordering \succsim of \mathcal{D} . One of their key assumptions, and one that has been strongly criticized by Balch (1974), Balch and Fishburn (1974), and Fishburn (1974) and defended by Krantz and Luce (1974), is that \mathcal{D} is closed under unions of decisions on disjoint events and under restrictions to nonempty subevents. The axioms, too complex to restate here, are sufficient to show that a real-valued function u exists on \mathcal{D} that is order-preserving and a probability measure P exists on \mathcal{E} such that for A, B in \mathcal{E} with $A \cap B = \phi$ and f_A, g_B in \mathcal{D} ,

$$u(f_A \cup g_B) = u(f_A)P(A|A \cup B) + u(g_B)P(B|A \cup B).$$

This is the conditional expected utility property.

No attempt is made here to outline the proof, but it involves looking at all the decisions on triples of mutually disjoint events, showing that these are additive conjoint structures, and using the uniqueness theorem for such structures to introduce the probability measures. To the extent that such structures are of interest in decision making (and I think there are good reasons to believe they are considerably more satisfactory than Savage's system), conjoint measurement has been put to important use.

6.4.3 ALGEBRA OF PHYSICAL QUANTITIES

Physical measures exhibit two quite different numerical structures; some involve an operation that satisfies the axioms of extensive (or more general) concatenation measurement, and some triples of measures are related by equations of the form

$$z = x^\alpha y^\beta,$$

where some or all of x , y , and z are extensive measures. In the latter case, it is clear that the ordering induced by z on the structure of (x, y) pairs must satisfy the axioms of additive conjoint measurement. So, again, we see that this algebra must play a role in a qualitative development of the measurement underpinnings

of physical measures. The main problems in building such a theory are, first, to formulate the qualitative interlock between the extensive and conjoint structures and, second, to characterize the exponents α and β . Krantz *et al.* (1971, Chapter 10) have made an attempt to do this, based primarily on the work of Luce (1965). An improved version is provided by Narens and Luce (1975), and it is outlined here.

Basically, there are two cases to be considered. Suppose that $\langle A \times P, \succeq \rangle$ is a conjoint structure satisfying independence and that there is either an operation \circ_A on A (or \circ_P on P) or an operation \circ on $A \times P$. In the former case we assume the following distribution condition:

$$\text{if } (a, p) \sim (c, q) \text{ and } (b, p) \sim (d, q), \text{ then } (a \circ b, p) \sim (c \circ d, q).$$

In the latter case, distribution takes the form

$$(a, p) \circ (b, p) \sim (c, p) \text{ iff } (a, q) \circ (b, q) \sim (c, q).$$

This permits us to define \circ_A by

$$a \circ_A b = c \text{ if for some } p, \text{ hence for any } p, (a, p) \circ (b, p) \sim (c, p),$$

and this operation satisfies the first condition. What Narens and Luce prove is that, under solvability conditions, if \circ_A is an extensive operation with an additive representation ϕ_A , then there is a scale ϕ'_P on P such that $\phi_A \phi'_P$ is order-preserving. Thus, distributivity coupled with extensiveness forces the conjoint structure to be additive. If, in addition, \circ_P exists and is extensive with an additive representation ϕ_P , then there are constants α, β such that $\phi_A^\alpha \phi_P^\beta$ is order-preserving.

Because of the uniqueness of additive conjoint measurement, only the value of α/β is of significance. To characterize its value, one need only state the exchange relation between concatenations on the two factors as follows: there are positive integers m and n such that for all a in A and p in P , either

$$(2^m a, p) \sim (a, 2^n p)$$

or

$$(2^m a, 2^n p) \sim (a, p).$$

Under these conditions, $|\alpha/\beta| = n/m$. Such statements are easily derived from the representation.

In addition to laws of exchange, one must also consider cases where there is an operation \circ on $A \times P$ and \circ_A on A . In such cases, the corresponding laws, called laws of similitude, take the form either

$$2^m(a, p) \sim (2^n a, p)$$

or

$$2^m(2^n a, p) \sim (a, p).$$

Krantz *et al.* (1971, section 10.9) show how a family of physical attributes — some of which are extensive and some triples of which are related, as above, either

by laws of exchange or similitude – can be represented, in essence, as a multiplicative vector space with a finite basis of extensive quantities. This is the model of physical measures usually assumed in dimensional analysis. Thus, this theory appears to serve as the qualitative basis for physical measurement – at least in the classical case.

But there is still at least one vexing problem: the interplay of measures in relativistic and quantum physics. The most striking exception to the distribution property is provided by relativistic velocity. Let $D = V \times T$ denote distances formed by pairing velocities with times – all qualitative. Let \succsim be the usual ordering of distances. Let \circ_D , \circ_V , and \circ_T be the usual concatenations of distance, of velocity (frames of references), and of times. And let ϕ_D , ϕ_V , ϕ_T be the usual numerical measures of distance, velocity, and time. Then, even though $\langle V, \succsim_V, \circ_V \rangle$ is an extensive structure, the representation is:

$$\begin{aligned}\phi_D(v, t) &= \phi_V(v) \phi_T(t) \\ \phi_D[(v, t) \circ_D (v', t')] &= \phi_D(v, t) + \phi_D(v', t') \\ \phi_T(t \circ_T t') &= \phi_T(t) + \phi_T(t') \\ \phi_V(v \circ_V v') &= \frac{\phi_V(v) + \phi_V(v')}{1 + \frac{\phi_V(v) \phi_V(v')}{\phi_V(c)^2}}\end{aligned}$$

where c denotes the velocity of light moving in a vacuum. In this case, \circ_V does not satisfy the distributivity condition.

Although the velocity formula has been given qualitative expression by Luce and Narens (In press), it is not really satisfactory for the construction of the algebra of physical quantities. An appropriate analogue to the distributive property is needed.

In summary, it is evident that the concepts of conjoint measurement are essential to a qualitative understanding of the algebra of physical measurement. The difficult problem that remains is to establish the qualitative connection between the extensive and conjoint structures that fail to satisfy distributivity. It is worth noting that, when confronted with this problem, physicists retain the multiplicative representation of the conjoint structure and abandon the additive representation of the extensive one. This is not exactly what one would have anticipated from the emphasis placed by philosophers of physics (e.g., Campbell, 1920; Nagel, 1961) on the additive representation of extensive structures.

6.4.4 MEANINGFULNESS AND DIMENSIONAL INVARIANCE

Dimensional analysis works when one both knows all of the relevant variables and assumes that the law relating them is dimensionally invariant. Roughly, this means

that changes in the units of measurement do not alter the mathematical form of the law. More exactly, it means that the law is some unknown function of one or more products of powers of subsets of the variables, where each of the products is dimensionless. The question has long been asked why physical and other scientific laws should exhibit this property (see Chapter 10 of Krantz *et al.*, 1971, for a detailed discussion).

Apparently independent of that discussion, another one in the measurement literature has concerned which statements, framed entirely in terms of a single dimension, can be considered meaningful. For example, it is agreed that it is meaningful to say that one mass is ten times as heavy as another, but that it is not meaningful to say that today's temperature is 10% less than yesterday's. The consensus (see Pfanzagl, 1971) is that a statement is meaningful if and only if it is invariant under the group of transformations describing the uniqueness of the scale. Clearly, this criterion is the natural analogue of dimensional invariance when there is only one dimension.

In both cases one can raise the question of what in the underlying qualitative structure corresponds to a meaningful statement or to a dimensionally invariant one. Recently (Luce, 1976), I have shown that there is a simple answer. Intuitively, a relation in a qualitative relational structure is meaningful if it can be expressed in terms of the relations that define the structure. This is given formal meaning as follows: By an automorphism of the structure one means any one-to-one transformation of the elements that leaves the defining relations invariant. Another relation is then said to be meaningful within a structure if and only if it does not further reduce the set of automorphisms, i.e., it is also invariant under the automorphisms of the structure. It is easy to see that this corresponds exactly to the usual definition of meaningfulness in terms of scales of measurement; it is somewhat more interesting to show in the case of the construction underlying the algebra of physical quantities how it corresponds exactly to dimensional invariance.

6.5 EMPIRICAL APPLICATIONS

It is widely felt that there have been fewer applications of conjoint measurement to date than might be expected from the interest in the theory. There are probably many reasons: difficulty in understanding how the theory and representations relate, doubts about what sort of design is best suited to testing the model and what sort is suited to constructing representations, and lack of satisfactory statistical procedures. Psychologists, for example, have been slow in fully understanding what sorts of data are needed to reject simple algebraic representations. They have long recognized that in 2×2 factor designs "crossed" data – a violation of independence – reject an additive representation. Indeed, as we have seen, a failure of simple factor independence rejects any monotonically decomposable representa-

tion. Relatively few understand that to test additivity one should look carefully into double cancellation, which means at a minimum a 3×3 design, or into multiple-factor independence when there are more than two factors. Similarly, the debates between Hull (1952) and Spence (1956) over the formulation of habit strength models amount to choices, based on three factors, between two of the four simple polynomials. It is interesting that in all the years of empirical research on that problem, it appears that no one conducted an experiment adequate to make the choice. One should keep in mind examples such as these, and their waste of effort and resources, when dismissing fundamental measurement theory as an arcane subject of no empirical value.

Examples will be presented here of various empirical approaches that rest on additive conjoint techniques, either directly or indirectly, and on techniques for the simple polynomials. Basically, four approaches have been taken to constructing the representation: rescaling of a numerical function, construction of a function using standard sequence techniques, scaling using factorial methods, and testing of axioms. These three constructions are treated in the next section, and the testing of axioms is treated in section 6.5.2.

6.5.1 CONSTRUCTION OF AN ADDITIVE REPRESENTATION

Scheffé (1959) (see discussion in Krantz *et al.*, 1971, section 6.5.3; and Aczél, 1965) provided a mathematical solution to the following problem: given a numerical scale ϕ on $A \times P$, when is there f , ϕ_A , and ϕ_P such that

$$f\phi = \phi_A + \phi_P?$$

Explicit expressions for f , ϕ_A , and ϕ_P are known. This is true whenever either f is given as an explicit mathematical function or it can be approximated numerically. An example of the former was discussed by Krantz *et al.* (1971, section 6.4.2): Campbell and Masterson (1969) had fit factorial data with a function that, when appropriately transformed, yielded an additive representation.

In principle, the same techniques can be used on data obtained by category or magnitude methods, although in practice (e.g., Anderson, 1974) it seems to be more usual to try to fit the data directly to an additive or averaging model. For example, Feldman and Baird (1971) performed magnitude estimation first on loudness and on brightness separately, finding the usual power functions of physical intensity, and then on the two jointly. They attempted to fit the resulting responses by a geometric mean and by an averaging model based on the functions for the two modalities separately, and the averaging model fit reasonably well.

Although standard sequences are the major theoretical device in constructing additive representations, it seems that only one psychological study has employed it. Levelt *et al.* (1972) used the technique to study loudness summation over the two ears. The stimuli were pairs of intensities of a 1000-Hz tone, with different

intensities directed at each ear. Two such stimuli would be presented with only a short time between them, and the subject was asked either to order them by loudness or to modify one of the intensities until a loudness match was achieved. It was found that an additive representation seemed adequate and that the functions ϕ_L and ϕ_R (for the left and right ears) were approximately power functions of physical intensity with exponents comparable to those found using magnitude methods. This result is both satisfying and disquieting. It is satisfying because the growth of loudness is comparable to that found by other methods and because additivity across the ears is so simple. It is disquieting because there are other reasons, among them physiological evidence for crossovers between the ears, to doubt the additivity of loudness. This is treated further in section 6.7.

Perhaps the most congenial approach to conjoint measurement for many social scientists, especially those heavily influenced by analysis-of-variance designs, is the factorial approach. For example, Tversky (1967b) used the method to study the expected utility model in which subjects chose between gambles in which a desired consequence occurred with some probability and nothing occurred with the complementary probability. If the utility of nothing is assumed to be zero, then if c is the consequence and A is the chance event, the subjective expected utility hypothesis (SEU) becomes $u(c)P(A)$, which is an additive (under a logarithmic transformation) conjoint representation. Tversky's data, derived from work with prisoners, involved cigarettes and candy as consequences. Additive solutions, using the Tversky and Zivian (1966) program, were found to fit the data well. (For details, see Tversky, 1967b, or Krantz *et al.*, 1971, section 9.4.2.)

The most disturbing aspect of these data, from the point of view of an expected utility theorist, is that if one demands that the probability measure be additive in the sense that $P(A) + P(\bar{A}) = 1$, then it is impossible to demand also that the utility functions obtained from two different procedures, one involving only gambles and the other pure consequences, be the same.

Since 1971, P.E. Green and his associates (Green and Rao, 1971; Green, 1974; Green and Devita, 1974; and Green and Wind, 1975) have been advocating and illustrating the use of the factorial conjoint measurement in various marketing contexts. It remains to be seen whether it will prove sufficiently useful to warrant general adoption.

It is perhaps worth noting here that the techniques of Anderson and his students (for surveys, see Anderson, 1970, 1971, 1974) can be viewed as a program of fitting additive and averaging models to factorial data. The major differences from the techniques so far discussed appear to be that Anderson tends to treat the numerical responses as the scale to be used in testing a representation, that he uses analysis-of-variance techniques on these numbers to decide on the adequacy of the model, and that he usually uses averaging models.

6.5.2 TESTING AXIOMS

Although one may sometimes want or need the numerical representation, the scientific interest is often not in the resulting numbers but in whether we know the relevant independent factors that underlie the subject's behavior. In such cases, it is probably wiser to design studies directly aimed at testing particular axioms, such as independence, double cancellation, or one or another of the distributivity axioms. Krantz (1972, 1974) makes a strong case for this approach, giving a number of illustrations.

We consider studies that have focused on the independence property (which, it will be recalled, implies double cancellation when three or more factors are involved and solvability is satisfied). There is also a literature on transitivity, which we shall not go into here. Perhaps the best-studied example of independence is the property known as the extended sure-thing principle of expected utility theory: if (a, A, b) denotes a gamble in which a is the consequence if event A occurs and b is the consequence if \bar{A} occurs, then the extended sure-thing principle (extended because a may itself be a gamble) is

$$(a, A, b) \succeq (a', A, b) \text{ iff } (a, A, b') \succeq (a', A, b').$$

Ellsberg (1961) focused attention on this property by discussing instances in which reasonable people feel they would violate it. MacCrimmon (1968) reported about 25 percent failure of the property among middle-rank business executives confronted with hypothetical business problems. Becker and Brownson (1974), using graduate students of business, found a violation rate of nearly 50 percent. MacCrimmon and Larsson (In press) give a careful analysis of the problem and report an extensive empirical study in which, again, a substantial proportion of the subjects violate the extended sure-thing principle. It should be realized how sweeping this conclusion is: it not only rejects the SEU model but also invalidates any form of monotonic decomposition that says preferences can be expressed in the form

$$F[\phi(a, A), \phi(b, \bar{A})],$$

where F is strictly increasing in each argument.

The full significance of this for the study of choices under uncertainty seems not to have been fully appreciated. For example, a number of studies attacking SEU (Slovic and Lichtenstein, 1968; Payne, 1973a, b; Payne and Brauneis, 1971) have proposed various alternative models that are decomposable and, hence, are inconsistent with the empirical results cited above.

C.H. Coombs and his students have taken the failures of SEU seriously and have proposed that our preferences for uncertain situations are heavily influenced by a concept of risk. In an attempt to gain some understanding of how various aspects of a gamble affect risk, they have manipulated three factors of gambles and attempted to decide among the four simple polynomial models using the procedures of Krantz and Tversky (1971). Coombs and Huang (1970) showed that only the distributive model was supported. Later, however, Coombs and Bowen (1971),

using closely related gambles in which the odds were changed without varying either the expected value or variance, showed that risk varied with the odds. This rejected not only an axiomatization of risk published by Pollatsek and Tversky (1970) but also the distributive model. The cause of this inconsistency is not known.

Tversky and Krantz (1969) did a three-factor study of schematic faces that were varied as follows: long versus wide faces, open versus solid eyes, and straight versus curved mouths. Subjects judged comparative similarities of pairs. Tests of independence were well supported in this case.

A body of literature, typified by the work of Phillips and Edwards (1966) and Edwards (1968), has focused on how well Bayes' theorem describes human probabilistic information processing. If we let Ω_0 denote the prior odds of two hypotheses, H_1 and H_2 ; Ω_n the posterior odds after observing n sources of information; and L the likelihood ratio of these data having arisen under the two hypotheses, we have from Bayes' theorem the additive representation

$$\log \Omega_n = \log L + \log \Omega_0.$$

Wallsten (1972) pointed out that in order to understand how the information is being assimilated, it may be useful to regard this as a conjoint measurement problem in the subjects' responses. He reported an experiment in which the probability of the data conditional on each hypothesis, $P(D|H_i)$, and the number n of independent observations were varied. Using the procedures of assessing three-factor simple polynomial models outlined by Krantz and Tversky (1971), the distributive model

$$\phi_3(n) [\phi_1(D|H_1) - \phi_2(D|H_2)]$$

was sustained for 8 of 12 subjects. A number of substantive interpretations are made from the calculated functions. Wallsten [In press (a, b)] and Wallsten and Sapp (In press) have followed up this work.

6.6 ERROR

In any attempt either to test or to fit a measurement model to data, a major difficulty is error. Everyone is confident that there is some element of inconsistency in subjects' responses. We know that if we embed a choice in a long series of choices, we do not necessarily get the same response each time it is presented. Whether this is due to fatigue, to changes in attitude resulting from previous choices, or to other sources of variability, we cannot be sure. But whatever the causes, it is clearly inappropriate to demand exact fits of the model to data or to reject an axiom every time an apparent failure occurs.

Although we have been well aware of these difficulties from the first tests of SEU – e.g., those of Mosteller and Nogee (1951) – it is surprising how little has been done to rectify them. Some probabilistic work on transitivity has been done,

and some probabilistic choice models have been developed, but within the context of either concatenation measurement structures or conjoint ones, little has been done. The most significant breakthrough is the work of Falmagne (1976); it was motivated by the study of Levelt *et al.* (1972) and the difficulty they had in taking into account the statistical nature of the data.

Falmagne assumes that when a subject is asked to solve an equation of the form

$$(a, p) \sim (b, q)$$

for, let us say, b (e.g., these are intensities to the left and right ears and the judgment is equal loudness), then b is really a random variable $\tilde{U}_{pq}(a)$. He then supposes that the appropriate additive representation is comparable to the analysis-of-variance models, namely,

$$\phi_A[\tilde{U}_{pq}(a)] = \phi_A(a) + \phi_P(p) - \phi_P(q) + \tilde{e}_{pq}(a),$$

where $\tilde{e}_{pq}(a)$ is a random variable with 0 median.

The key property used in the analysis is that if \tilde{X} is a random variable, ϕ a strictly increasing function, and M the median operator, then

$$M[\phi(\tilde{X})] = \phi[M(\tilde{X})];$$

i.e., M and ϕ commute. Then, writing

$$m_{pq}(a) = M[\tilde{U}_{pq}(a)],$$

he proves from the representation that the following *cancellation* property must hold:

$$m_{pr}(a) = m_{pq}[m_{qr}(a)],$$

which corresponds to the double cancellation property. A second property, corresponding to transitivity, is *commutativity*:

$$m_{pq}[m_{rs}(a)] = m_{rs}[m_{pq}(a)].$$

Falmagne shows that if we define \succsim on $A \times P$ by

$$(a, p) \succsim (b, q) \text{ iff } m_{pq}(a) \geq b$$

and assume that A and P are real intervals, that m is strictly increasing, and that m satisfies the cancellation and commutativity properties, then \succsim is a weak order that satisfies double cancellation (and so independence because of solvability).

He then outlines methods of testing these two properties using median tests. So far, only pilot data for loudness summation have been published (Falmagne, 1976); they indicate small but systematic failures in the cancellation property, suggesting that additivity may not hold strictly. It is, however, much too early to be sure. Additional data will soon be reported.

6.7 CONCLUSIONS

It is reasonably clear that the simplest, best-known case of conjoint measurement, the additive representation, has limited direct application to human decision processes (section 6.5). Its main value is, first, in understanding more clearly the basic measurement structures of physics (sections 6.4.3 and 6.4.4), with the hope of eventually generalizing that structure to include behavioral and social science variables, and second, in providing a tool for analyzing the structure and representation of more complex conjoint structures. Examples of the latter are the study of certain nonadditive representations (section 6.3) and of conditional expected utility (section 6.4.2), which is of interest to decision analysts, economists, and statisticians. One can, therefore, anticipate considerable future work on the development and empirical testing of somewhat special, but still interesting, non-additive representations. Experimental tests will continue to be somewhat frustrating until an adequate theory of error is evolved (section 6.6).

REFERENCES

- Aczél, J. 1965. A remark on functional dependence. *Journal of Mathematical Psychology*, vol. 2, pp. 125–127.
- Aczél, J., G. Pickert, and F. Radó. 1960. Nomogramme, Gewebe und Quasigruppen. *Mathematica*, Vol. 2, pp. 5–24.
- Anderson, N.H. 1970. Functional measurement and psychophysical judgment. *Psychological Review*, Vol. 77, pp. 153–170.
- Anderson, N.H. 1971. Integration theory and attitude change. *Psychological Review*, Vol. 78, pp. 171–206.
- Anderson, N.H. 1973. Comments on the articles of Hodges and of Schönemann, Cafferty, and Rotton. *Psychological Review*, Vol. 80, pp. 88–92.
- Anderson, N.H. 1974. Information integration theory: a brief survey. In *Contemporary Developments in Mathematical Psychology, II* (D.H. Krantz, R.C. Atkinson, R.D. Luce, and P. Suppes, eds.). Freeman, San Francisco, pp. 236–305.
- Balch, M. 1974. On recent developments in subjective expected utility. In *Essays on Economic Behavior under Uncertainty* (M.S. Balch, D.L. McFadden, and S.Y. Wu, eds.). North-Holland, Amsterdam, pp. 45–55.
- Balch, M., and P.C. Fishburn. 1974. Subjective expected utility for conditional primitives. In *Essays on Economic Behavior under Uncertainty* (M.S. Balch, D.L. McFadden, and S.Y. Wu, eds.). North-Holland, Amsterdam, pp. 57–69.
- Becker, S.W., and F.O. Brownson. 1964. What price ambiguity? or the role of ambiguity in decision-making. *Journal of Political Economy*, Vol. 72, pp. 62–73.
- Blaschke, W., and G. Bol. 1938. *Geometrie der Gewebe*. Springer, Berlin.
- Campbell, B.A., and F.A. Masterson. 1969. Psychophysics of punishment. In *Punishment and Aversive Behavior*. (B.A. Campbell and R.M. Church, eds.). Appleton-Century-Crofts, New York, pp. 3–42.
- Campbell, N.R. 1920. *Physics: the Elements*. Cambridge University Press, Cambridge. Reprinted in 1957 as *Foundations of Science: The Philosophy of Theory and Experiment*. Dover, New York.
- Coombs, C.H., and J. Bowen. 1971. Additivity of risk in portfolios. *Perception and Psychophysics*, Vol. 10, pp. 43–46.

- Coombs, C.H., and L.C. Huang. 1968. A portfolio theory of risk preference. Michigan Mathematical Psychology Program, Technical Report 68-5. University of Michigan, Ann Arbor.
- Coombs, C.H., and L.C. Huang. 1970. Polynomial psychophysics of risk. *Journal of Mathematical Psychology*, Vol. 7, pp. 317-338.
- Debreu, G. 1960. Topological methods in cardinal utility theory. In *Mathematical Methods in the Social Sciences, 1959* (K.J. Arrow, S. Karlin, and P. Suppes, eds.). Stanford University Press, Stanford, California.
- Edwards, W. 1968. Conservatism in human information processing. In *Formal Representation of Human Judgment* (B. Kleinmunts, ed.). Wiley, New York.
- Ellsberg, D. 1961. Risk, ambiguity, and the Savage axioms. *Quarterly Journal of Economics*, Vol. 75, pp. 643-669.
- Falmagne, J.C. 1973. Sufficient conditions for an ordered-ring isomorphism onto a positive subinterval: a lemma for polynomial measurement. *Journal of Mathematical Psychology*, Vol. 10, pp. 290-295.
- Falmagne, J.C. 1976. Random conjoint measurement and loudness summation. *Psychological Review*, Vol. 83, pp. 65-79.
- Feldman, J., and J.C. Baird. 1971. Magnitude estimation of multidimensional stimuli. *Perception and Psychophysics*, Vol. 10, pp. 418-422.
- Fishburn, P.C. 1974. On the foundations of decision making under uncertainty. In *Essays on Economic Behavior under Uncertainty* (M.S. Balch, D.L. McFadden, and S.Y. Wu, eds.). North-Holland, Amsterdam.
- Fishburn, P.C. 1975. Nondecomposable conjoint measurement for bisymmetric structures. *Journal of Mathematical Psychology*, Vol. 12, pp. 75-89.
- Green, D.M., and R.D. Luce. 1974. Variability of magnitude estimates: a timing theory analysis. *Perception and Psychophysics*, Vol. 15, pp. 291-300.
- Green, P.E. 1974. On the design of choice experiments involving multifactor alternatives. *Journal of Consumer Research*, Vol. 1, pp. 61-68.
- Green, P.E., and M.T. Devita. 1974. A complementarity model of consumer utility for item collections. *Journal of Consumer Research*, Vol. 1, pp. 56-67.
- Green, P.E., and V.R. Rao. 1971. Conjoint measurement for quantifying judgmental data. *Journal of Marketing Research*, Vol. 8, pp. 355-363.
- Green, P.E., and Y. Wind. 1975. New Way to measure consumers' judgments. *Harvard Business Review*, pp. 107-117.
- Havel, V. 1966. Verallgemeinerte Gewebe. I. *Arch. Math. (Brno)*, Vol. 2, pp. 63-70.
- Hodges, B.H. 1973. Adding and averaging models for information integration. *Psychological Review*, Vol. 80, pp. 80-84.
- Holman, E.W. 1971. A note on additive conjoint measurement. *Journal of Mathematical Psychology*, Vol. 8, pp. 489-494.
- Hull, C.L. 1952. *A Behavior System*. Yale University Press, New Haven, Connecticut.
- Jaffray, J.Y. 1974. On the extension of additive utilities to infinite sets. *Journal of Mathematical Psychology*, Vol. 11, pp. 431-452.
- Krantz, D.H. 1968. A survey of measurement theory. In *Mathematics of the Decision Sciences, Part 2* (G.B. Dantzig and A.F. Veinott, Jr., eds.). Vol. 12. Lectures in Applied Mathematics, American Mathematical Society, Providence, Rhode Island, pp. 314-350.
- Krantz, D.H. 1972. Measurement structures and psychological laws. *Science*, Vol. 175, pp. 1427-1435.
- Krantz, D.H. 1974. Measurement theory and qualitative laws in psychophysics. In *Contemporary Developments in Mathematical Psychology, II* (D.H. Krantz, R.C. Atkinson, R.D. Luce, and P. Suppes, eds.). Freeman, San Francisco, pp. 160-199.
- Krantz, D.H., and R.D. Luce. 1974. The interpretation of conditional expected-utility theories. In *Essays on Economic Behavior under Uncertainty* (M.S. Balch, D.L. McFadden, and S.Y. Wu, eds.). North-Holland, Amsterdam, pp. 70-73.

- Krantz, D.H., R.D. Luce, P. Suppes, and A. Tversky. 1971. *Foundations of Measurement, I*. Academic Press, New York.
- Krantz, D.H., and A. Tversky. 1971. Conjoint-measurement analysis of composition rules in psychology. *Psychological Review*, Vol. 78, pp. 151–169.
- Levelt, W.J.M., J.B. Riemersa, and A.A. Bunt. 1972. Binaural additivity of loudness. *British Journal of Mathematical and Statistical Psychology*, Vol. 25, pp. 51–68.
- Levine, M.V. 1970. Transformations that render curves parallel. *Journal of Mathematical Psychology*, Vol. 7, pp. 410–444.
- Levine, M.V. 1972. Transforming curves into curves with the same shape. *Journal of Mathematical Psychology*, Vol. 9, pp. 1–16.
- Levine, M.V. 1975a. Additive measurement with short segments of curves. *Journal of Mathematical Psychology*, Vol. 12, pp. 212–224.
- Levine, M.V. 1975b. Appropriateness measurement and test bias. Unpublished manuscript.
- Luce, R.D. 1965. A “fundamental” axiomatization of multiplicative power relations among three variables. *Philosophy of Science*, Vol. 32, pp. 301–309.
- Luce, R.D. 1966. Two extensions of conjoint measurement. *Journal of Mathematical Psychology*, Vol. 3, pp. 348–370.
- Luce, R.D. 1976. Dimensionally invariant numerical laws correspond to meaningful relations. Unpublished manuscript.
- Luce, R.D., and D.H. Krantz. 1971. Conditional expected utility. *Econometrica*, Vol. 39, pp. 253–271.
- Luce, R.D., and L. Narens. In press. A qualitative equivalent to the relativistic addition law for velocities. *Synthese*.
- Luce, R.D., and J. Tukey. 1964. Simultaneous conjoint measurement: a new type of fundamental measurement. *Journal of Mathematical Psychology*, Vol. 1, pp. 1–27.
- MacCrimmon, K.R. 1968. Descriptive and normative implications of the decision-theory postulates. In *Risk and Uncertainty* (K. Borch and J. Mossin, eds.). Macmillan, New York, pp. 3–32.
- MacCrimmon, K.R., and S. Larsson. In press. Utility theory: axioms versus “paradoxes.” *Theory and Decision*.
- Marks, L.E. 1974. *Sensory Processes, the New Psychophysics*. Academic Press, New York.
- Moskowitz, H.R., B. Scharf, and J.C. Stevens, eds. 1974. *Sensation and Measurement*. Reidel, Dordrecht.
- Mosteller, F., and P. Noguee. 1951. An experimental measurement of utility. *Journal of Political Economy*, Vol. 59, pp. 371–404.
- Nagel, E. 1961. *The Structure of Science*. Harcourt, Brace & World, New York.
- Narens, L. 1974a. Measurement without Archimedean axioms. *Philosophy of Science*, Vol. 41, pp. 374–393.
- Narens, L. 1974b. Minimal conditions for additive conjoint measurement and qualitative probability. *Journal of Mathematical Psychology*, Vol. 11, pp. 404–430.
- Narens, L., and R.D. Luce. 1975. The algebra of measurement. Unpublished manuscript.
- Payne, J.W. 1973a. Alternative approaches to decision making under risk: Moments versus risk dimensions. *Psychological Bulletin*, Vol. 80, pp. 439–454.
- Payne, J.W. 1973b. Contingent information-processing in decision making under risk: the role of the basic risk dimensions. Ph.D. dissertation. University of California, Irvine.
- Payne, J.W., and M.L. Braunstein. 1971. Preferences among gambles with equal underlying distributions. *Journal of Experimental Psychology*, Vol. 87, pp. 13–18.
- Pfanzagl, J. 1971. *Theory of Measurement*. 2nd ed. Physica-Verlag, Vienna.
- Phillips, L.D., and W. Edwards. 1966. Conservatism in a simple probability inference task. *Journal of Experimental Psychology*, Vol. 72, pp. 346–354.
- Pollatsek, A., and A. Tversky. 1970. A theory of risk. *Journal of Mathematical Psychology*, Vol. 7, pp. 540–553.

- Radó, F. 1969. Eine Bedingung für die Regularität der Gewebe. *Mathematica (Cluj)*, Vol. 2, pp. 325–334.
- Radó, F. 1965. Einbettung eines Halbgewebes in ein reguläres Gewebe und eines Halbgruppoids in eine Gruppe. *Mathematische Zeitschrift*, Vol. 89, pp. 395–410.
- Ramsey, J.O. 1975. Review of Krantz *et al. Foundations of Measurement*, Vol. 1. *Psychometrika*, Vol. 40, pp. 257–262.
- Richter, M.K. 1975. Rational choice and polynomial measurement models. *Journal of Mathematical Psychology*, Vol. 12, pp. 99–113.
- Savage, L.J. 1954. *The Foundations of Statistics*. John Wiley, New York.
- Scheffé, H. 1959. *The Analysis of Variance*. John Wiley, New York.
- Schönemann, P.H., T. Cafferty, and J. Rotton. 1973. A note on additive functional measurement. *Psychological Review*, Vol. 80, pp. 85–87.
- Scott, D. 1964. Measurement structures and linear inequalities. *Journal of Mathematical Psychology*, Vol. 1, pp. 233–247.
- Scott, D., and P. Suppes. 1958. Foundational aspects of theories of measurement. *Journal of Symbolic Logic*, Vol. 23, pp. 113–128.
- Skala, H.J. 1975. *Non-Archimedean Utility Theory*. Reidel, Boston.
- Slovic, P. 1967. The relative influence of probabilities and payoffs upon perceived risk of a gamble. *Psychonomic Science*, Vol. 1, pp. 223–224.
- Slovic, P., and S. Lichtenstein. 1968. Relative importance of probabilities and payoffs in risk taking. *Journal of Experimental Psychology Monograph*, Vol. 78, pp. 1–18.
- Spence, K.W. 1956. *Behavior Theory and Conditioning*. Yale University Press, New Haven, Connecticut.
- Stevens, S.S. 1957. On the psychophysical law. *Psychological Review*, Vol. 64, pp. 153–181.
- Stevens, S.S. 1971. Issues in psychophysical measurement. *Psychological Review*, Vol. 78, pp. 426–450.
- Stevens, S.S. 1975. *Psychophysics*. John Wiley, New York.
- Tversky, A. 1964. Finite additive structures. Michigan Mathematical Psychology Program, Technical Report MMPP 64-6. University of Michigan, Ann Arbor.
- Tversky, A. 1967a. A general theory of conjoint measurement. *Journal of Mathematical Psychology*, Vol. 4, pp. 1–20.
- Tversky, A. 1967b. Additivity, utility, and subjective probability. *Journal of Mathematical Psychology*, Vol. 4, pp. 175–201.
- Tversky, A., and D.H. Krantz. 1969. Similarity of schematic faces: a test of interdimensional additivity. *Perception and Psychophysics*, Vol. 5, pp. 124–128.
- Tversky, A., and A. Zivian. 1966. A computer program for additivity analysis. *Behavioral Science*, Vol. 11, pp. 78–79.
- Wallsten, T.S. 1972. Conjoint-measurement framework for the study of probabilistic information processing. *Psychological Review*, Vol. 79, pp. 245–260.
- Wallsten, T.S. In press (a). Using conjoint measurement models to investigate a theory about probabilistic information processing. *Journal of Mathematical Psychology*, Vol. 13.
- Wallsten, T.S. In press (b). Processing information for decisions. In *Cognitive Theory* (N.J. Castellan, D. Pisoni, and G. Potts, eds.). Vol. 2. Erlbaum Associates, New York.
- Wallsten, T.S., and M.M. Sapp. In press. Strong ordinal properties of additive models for sequential processing of probabilistic information. *Acta Psychologica*, Vol. 44.
- Young, F. 1973. Conjoint scaling. The L.L. Thurstone Psychometric Laboratory Technical Report 118. The University of North Carolina, Chapel Hill.

7 Multiattribute Utilities in Expected Utility Theory

Peter C. Fishburn

7.1 INTRODUCTION

This paper is an examination of aspects of the problem of assessing multiattribute utilities within the context of a von Neumann–Morgenstern utility function on a multiattribute consequence space. Although there are well-known difficulties that can arise in assessing a utility function on a single attribute, such as net wealth, the paper will focus on problems that are peculiar to multiattribute situations. Prominent among these are the sheer magnitude of the assessment task that arises in a multidimensional context and the presence of evaluative interdependencies among attributes in many multiattribute decision problems.

The theme of the paper – and the aim of most theoretical work in multiattribute utility theory – is the investigation of possibilities for simplifying the task of multiattribute utility assessment. Accordingly, a large part of the paper will be devoted to the idea of expressing the n -attribute utility function as some combination of conditional single-attribute utility functions. To this end, a sequence of increasingly sophisticated independence conditions will be considered, beginning with the concept of value independence among attributes, which is associated with additive utility functions. Also examined are aspects of the concepts of utility independence and generalized utility independence, which, in appropriate combinations, lead to additive, multiplicative, or quasiadditive forms for the utility function. This is followed by a discussion of the concept of bilateral independence, which can accommodate more interdependencies among attributes but still allows the utility function to be written in terms of conditional single-attribute utility functions. The discussion of independence concludes with a general view of fractional independence that involves numerous special cases, including utility independence and bilateral independence. The final section, which is not predicated on any independence conditions, considers the use of conditional single-attribute utility functions in constructing approximations of arbitrary n -attribute utility functions.

Although I shall comment briefly on aspects of independence condition verification/negation and on scaling procedures, a much more complete treatment of these topics along with their theoretical background is provided in the recent book by Keeney and Raiffa (1976). This work, as well as selected references given later in the paper, offers detailed coverage of the subject matter reviewed here.

7.2 VON NEUMANN–MORGENSTERN UTILITIES

Although the expected utility theory of von Neumann and Morgenstern (1953) falls within the Luce and Raiffa (1957) category of decision making under risk, the ideas presented below can also be applied within their “decision under certainty” and “decision under uncertainty” categories. In the certainty context, one usually talks about multiattribute alternatives rather than multiattribute consequences. Although there are a variety of utility assessment techniques in the certainty context that do not rely on von Neumann–Morgenstern gambles, it is possible to introduce scaling probabilities into this context and evaluate utilities of multiattribute alternatives from the perspective of expected utility theory. It should not be inferred, however, that expected utility methods should be used for decision making under certainty, but only that they can be used if such use is believed to be helpful. On the other hand, it should be realized that nonprobabilistic methods for scaling utilities of multiattribute consequences (unique at least up to an order-preserving transformation) can sometimes be used to advantage in conjunction with a final gambles-based transformation in decision under risk/uncertainty contexts. I shall not consider these methods in the present review.

With regard to the decision under uncertainty category, it may be noted that Savage’s subjective expected utility theory (Fishburn, 1970b; Savage, 1972), which does not presume “known probabilities,” generates von Neumann–Morgenstern gambles in a natural way from the derived probability measure on the states of the world. Hence the developments of later sections apply to the Savage context as well as to the von Neumann–Morgenstern context.

Throughout the paper, X denotes a generic set of consequences of potential decisions with the understanding that, if x and y are any two distinct consequences in X , then they cannot both occur as the result of the decision that is actually made. In other words, the consequences in X are mutually exclusive. Moreover, it will be assumed that some consequence in X must result from the decision that is made.

We shall also let P denote the set of all simple probability measures or gambles on X . Thus each gamble p in P is a nonnegative real-valued function on X such that $p(x) > 0$ for, at most, a finite number of consequences in X with the sum of all $p(x)$ equal to unity. The gamble p is to be thought of as a real or hypothetical decision alternative that results in consequence x with probability $p(x)$. With $0 \leq \lambda \leq 1$, the convex combination $\lambda p + (1 - \lambda)q$ of gambles p and q is the gamble in P that assigns probability $\lambda p(x) + (1 - \lambda)q(x)$ to each x in X .

The von Neumann–Morgenstern axioms (von Neumann and Morgenstern, 1953) can be expressed in terms of a strict preference relation \succ on the set of gambles, with $p \succ q$ interpreted as “ p is preferred to q .” For later use we define the indifference relation \sim on P by $p \sim q$ if and only if neither $p \succ q$ nor $q \succ p$. The relation \succ on P is a *strict weak order* if, for all $p, q, r \in P$, $p \succ q$ and $q \succ p$ do not both hold (asymmetry), and either $p \succ r$ or $r \succ q$ when $p \succ q$ (negative transitivity). If \succ is a strict weak order, then \sim is an equivalence since it is then reflexive ($p \sim p$), symmetric (if $p \sim q$, then $q \sim p$) and transitive (if $p \sim q$ and $q \sim r$, then $p \sim r$). The axioms for \succ on P that are used in the following theorem are taken from Jensen (1967) and Fishburn (1970b). Together, they are equivalent to each of the axiom systems presented by von Neumann and Morgenstern (1953), Herstein and Milnor (1953), and Luce and Raiffa (1957).

THEOREM 1 There is a real-valued function u on X such that

$$p \succ q \text{ if and only if } \sum_X p(x)u(x) > \sum_X q(x)u(x), \text{ for all } p, q \in P, \tag{7.1}$$

if, and only if, the following hold for all $p, q, r \in P$:

AXIOM 1 \succ on P is a strict weak order.

AXIOM 2 If $0 < \lambda < 1$ and $p \succ q$, then $\lambda p + (1 - \lambda)r \succ \lambda q + (1 - \lambda)r$.

AXIOM 3 If $p \succ q$ and $q \succ r$, then there are λ and μ strictly between 0 and 1 such that $\lambda p + (1 - \lambda)r \succ q$ and $q \succ \mu p + (1 - \mu)r$.

Axiom 2 is a form of independence axiom that asserts the preservation of preference under similar convex combinations of gambles, and Axiom 3 is a type of continuity or Archimedean axiom. Although each axiom has been criticized for its lack of complete psychological reality (Allais, 1953; Thrall, 1954; Luce, 1956; Fishburn, 1972a, 1976; Slovic and Tversky, 1974), they will be assumed to hold in ensuing sections, with u satisfying (7.1).

To consider relationships between utility functions on which expected utility representations such as (7.1) are based, we shall say that v on X is an *affine transformation* of u on X if there are real numbers a and b such that $v(x) = au(x) + b$ for all x . This transformation is *positive*, *null*, or *negative* according to whether $a > 0$, $a = 0$, or $a < 0$. In addition, R^* will denote the dual or converse of any binary relation R , so that, for example, $p \succ^* q$ if and only if $q \succ p$; and \emptyset will denote the empty relation, with $\succ = \emptyset$ if and only if $p \succ q$ for no p and q .

THEOREM 2 Suppose (7.1) holds, $\succ \neq \emptyset$, and \succ' is a binary relation on P . Consider the representation

$$p \succ' q \text{ if and only if } \sum_X p(x)v(x) > \sum_X q(x)v(x), \text{ for all } p, q \in P. \tag{7.2}$$

If $\succ' = \succ$, then (7.2) holds if and only if v is a positive affine transformation of

u ; if $\succ' = \emptyset$, then (7.2) holds if and only if v is a null affine transformation of u ; if $\succ' = \succ^*$ then (7.2) holds if and only if v is a negative affine transformation of u . Moreover, if (7.2) holds and v is an affine transformation of u , then \succ' equals \succ , \emptyset or \succ^* , according to whether the transformation is positive, null, or negative.

The $\succ' = \succ$ part of Theorem 2 is alternatively expressed by saying that a von Neumann–Morgenstern utility function u is unique up to a positive affine (or positive linear) transformation, or that u is unique up to the choice of origin and scale unit, or that u is measured on an interval scale (Stevens, 1946).

7.2.1 A STANDARD SCALING PROCESS

A common process for scaling u begins with the choice of consequences x^1 and x^0 , with x^1 preferred to x^0 [strictly speaking, $p \succ q$ when $p(x^1) = q(x^0) = 1$]. These are assigned utility values that satisfy $u(x^1) > u(x^0)$ and that set the origin and scale unit for u . For convenience, $u(x^0) = 0$ and $u(x^1) = 1$ are often used. Then, if consequence x lies between x^0 and x^1 in preference, one estimates the probability α at which x is indifferent to p when $p(x^1) = \alpha$ and $p(x^0) = 1 - \alpha$, and, using (7.1), one obtains $u(x) = \alpha u(x^1) + (1 - \alpha)u(x^0)$. If x is preferred to x^1 or if x^0 is preferred to x , $u(x)$ is determined from (1) in a similar manner by comparing the intermediate consequence to gambles that involve the other two consequences.

Despite the apparent simplicity of this process, there can be many difficulties. First, it seems unlikely that one could identify a unique probability at which a gamble between two consequences is indifferent to an intermediate consequence. More likely, there will be a zone of indifference; for example, when $x^1 \succ x \succ x^0$ and $p(x^1) = \alpha$ and $p(x^0) = 1 - \alpha$, an individual may be undecided about whether he prefers x to p or p to x for a number of different values of α . This phenomenon is associated with the notion of nontransitive indifference discussed by Luce (1956) and Fishburn (1970a), among others. Second, the choice of fixed points x^0 and x^1 may affect the estimated u , in which case the process is subject to an anchoring effect (Tversky and Kahneman, 1974). Third, X may be very large or even infinite, in which case it is not possible to apply the process to all consequences in X .

These difficulties, which are present when X is unidimensional – a set of monetary values, for example – can be compounded when the consequences are complex entities composed of a number of aspects, characteristics, or attributes. It is therefore desirable to consider possible ways of simplifying the task of utility function assessment in multiattribute situations, and this is what we shall do in the rest of the paper.

7.2.2 MULTIATTRIBUTE CONSEQUENCES

Henceforth we shall view X as a subset of the Cartesian product of n other sets X_1, X_2, \dots, X_n . Thus $X \subseteq X_1 \times X_2 \times \dots \times X_n$, where the product is the set of all

n -tuples (x_1, x_2, \dots, x_n) for which $x_i \in X_i$ ($i = 1, \dots, n$). The X_i are factor sets, attributes, or whatever it seems appropriate to call them. For $x = (x_1, x_2, \dots, x_n)$ in X , x_i is the value or level of attribute X_i (or of the i th attribute) for consequence x .

In some cases the consequences in X present themselves in a natural multiattribute form with a natural order for the subscripts of the X_i . For example, if consequences are n -period income streams, then it is natural to take X_i as the set of potential incomes in period i . However, it is usually true that the consequences are not in a natural multiattribute form. Then it is necessary to identify the most important aspects of the consequences and to structure the X_i accordingly. In this case, the subscripts of the X_i are chosen by convention rather than by a natural ordering. The initially unstructured situation can, of course, be recast into a multiattribute formulation in many ways, and some effort is required to obtain a formulation that reflects the most important features of the consequences.

During the formulation process, a consequence x is mapped into an n -tuple (x_1, x_2, \dots, x_n) that, strictly speaking, is not identical to x . However, we shall write $x = (x_1, x_2, \dots, x_n)$, with the understanding that x in this usage is a reformulated consequence that is identified by the indicated n -tuple. Moreover, even though some elements in the set $X_1 \times X_2 \times \dots \times X_n$ may correspond to no actual consequence, it will be assumed that all elements in the product set can be evaluated by the decision maker, and we shall therefore take

$$X = X_1 \times X_2 \times \dots \times X_n \quad (7.3)$$

in ensuing sections. Theoretical complications that arise when X is allowed to be an arbitrary subset of the product set are discussed by Fishburn (1971, 1976).

It will also be assumed that each X_i is *essential* in the sense that for some fixed values of the other $n - 1$ attributes there are x_i^0 and x_i^1 in X_i such that $(x_1, \dots, x_{i-1}, x_i^1, x_{i+1}, \dots, x_n)$ is preferred to $(x_1, \dots, x_{i-1}, x_i^0, x_{i+1}, \dots, x_n)$. Beyond this, each attribute could have a variety of forms that surely affect scaling procedures for u and may affect some theoretical considerations. For example, X_i might be a two-element set such as {no, yes} or {0, 1}, with 0 and 1 indicating that a consequence does not or does satisfy a certain objective (Churchman and Ackoff, 1954), have a specified aspect (Tversky, 1972), or indicate inclusion of a specified project. The elements in X_i might be nonnumerical; X_i might be an interval of real numbers or a convex subset of a finite-dimensional Euclidean space; and so forth. In addition, the various X_i may be essentially similar, as in the income stream example, or they may be very different, which is usually the case in an initially unstructured situation. Although many of the developments in ensuing sections depend in no way on the specific structure of the attributes, other results or scaling procedures are tied to particular structural assumptions, and, when this is true, it will be noted explicitly.

7.3 ADDITIVE UTILITIES AND VALUE INDEPENDENCE

Given (7.1) and (7.3), u is additive in the attributes if and only if there are

real-valued functions u_1, u_2, \dots, u_n on X_1, X_2, \dots, X_n , respectively, such that

$$u(x_1, x_2, \dots, x_n) = u_1(x_1) + u_2(x_2) + \dots + u_n(x_n) \quad \text{for all } x \in X. \quad (7.4)$$

Debreu (1960) and Luce and Tukey (1964) identified axioms on preferences that imply (7.4) in a nonprobabilistic setting. The first axiomatizations for additive utilities in the context of (7.1) were provided by Fishburn (1965) and Pollak (1967).

For each i let P_i denote the set of gambles on X_i , and for a gamble p in P let p_1, p_2, \dots, p_n be its marginal gambles on X_1, X_2, \dots, X_n , respectively. Thus, if $p(x_1, x_2) = p(y_1, y_2) = 1/2$ for $n = 2$, then $p_1(x_1) = p_1(y_1) = 1/2$ with $p_1 \in P_1$, and $p_2(x_2) = p_2(y_2) = 1/2$ with $p_2 \in P_2$. Exactly the same marginal gambles are obtained from q in P when $q(x_1, y_2) = q(y_1, x_2) = 1/2$ even though p and q are very different. For example, if the consequences are two-period income streams (x_1, x_2) with x_i the income in period i , let

$$\begin{aligned} p(\$10,000, \$10,000) &= p(\$20,000, \$20,000) = 1/2, \\ q(\$10,000, \$20,000) &= q(\$20,000, \$10,000) = 1/2. \end{aligned}$$

Then $p_1 = q_1$ and $p_2 = q_2$. Some people would prefer q to p since q guarantees \$20,000 in some period, whereas there is a 50 percent chance of getting only \$10,000 in both periods under p . A general form of such behavior is called multivariate risk aversion by Richard (1975) and conservatism by Fishburn (1975). On the other hand, $p \succ q$ shows evidence of multivariate risk seeking. As we shall see momentarily, neither type of behavior satisfies (7.4). For (7.4) to hold, it must be true that p and q are indifferent.

7.3.1 VALUE INDEPENDENCE

Additive utilities are implied by a condition of value independence that says that the relative preference of a gamble depends only on its marginal gambles on the attributes and not on the way in which the attribute values are combined to form consequences.

DEFINITION 1 The attributes are *value independent* if and only if $p \sim q$ whenever p and q are gambles in P whose marginal gambles p_1, \dots, p_n and q_1, \dots, q_n satisfy $p_i = q_i$ for $i = 1, \dots, n$.

Actually, as noted by Fishburn (1965) and Raiffa (1969), a simplified condition, which uses only 50–50 gambles and employs an arbitrary fixed consequence $x^0 = (x_1^0, \dots, x_n^0)$, is equivalent to value independence in the context of (7.1) and (7.3).

LEMMA 1 The attributes are value independent if and only if the 50–50 gamble between x^0 and x is indifferent to the 50–50 gamble between y and z

whenever $x, y,$ and z are consequences for which $x \neq x^0$ and $\{x_i^0, x_i\} = \{y_i, z_i\}$ for $i = 1, \dots, n$.

The condition in Lemma 1 is useful for testing the validity of value independence. In doing this, the fixed consequence x^0 can be chosen in any convenient manner. As suggested above, value independence will often be invalid in an income stream context, and it may well be invalid in most situations where the attractiveness of an attribute's value depends critically on the values or levels of the other attributes. For example, if one prefers red wine to white wine with roast beef but white wine to red wine with fish, then the different classes of items on the menu cannot be value independent. In a controlled experiment involving several two-attribute situations (e.g., careers versus salaries, destination versus mode of transportation) Delbeke and Fauville (1974) concluded that most subjects violated the requirements of value independence. Nevertheless, in those situations where it holds, or holds approximately, it leads to a significant simplification of the task of utility measurement.

THEOREM 3 There are real-valued functions u_1, u_2, \dots, u_n on the attributes that satisfy (7.4) if, and only if, the attributes are value independent. Given (7.4) and an affine transformation $v = au + b, a > 0$, real-valued functions v_1, v_2, \dots, v_n on the attributes satisfy

$$v(x_1, x_2, \dots, x_n) = v_1(x_1) + v_2(x_2) + \dots + v_n(x_n), \quad \text{for all } x \in X,$$

if and only if there are numbers b_1, b_2, \dots, b_n such that $b = b_1 + \dots + b_n$ and

$$v_i(x_i) = au_i(x_i) + b_i \quad \text{for all } x_i \in X_i; i = 1, \dots, n.$$

Thus, value independence is both necessary and sufficient for additive utilities. Moreover, the scale units of the u_i functions are invariant with respect to one another. That is, if (7.4) holds and the u_i are aligned or scaled properly, and if one u_i is changed by multiplying it by a positive constant, then all other u_i must be multiplied by the same constant. In this connection it should be noted that the weighted additive form

$$u(x_1, x_2, \dots, x_n) = w_1u'_1(x_1) + w_2u'_2(x_2) + \dots + w_nu'_n(x_n), \quad (7.5)$$

in which the w_i are positive numbers or "weights," is neither more nor less general than (7.4). If both (7.4) and (7.5) hold, then Theorem 3 says that $w_iu'_i(x_i) = u_i(x_i) + b_i$ for each i , with $\sum b_i = 0$.

Many of the procedures outlined by Fishburn (1967b) for estimating the u_i when (7.4) holds are designed for specific attribute structures such as those mentioned at the end of section 7.2. One class of methods uses the following approach. First, select x_i^1 and x_i^0 for each i with x_i^1 preferred to x_i^0 and, as allowed by Theorem 3, set the origin for each u_i by taking $u_i(x_i^0) = 0$. Suppose, for definiteness, that $(x_1^1, x_2^0, \dots, x_n^0) \succ (x_1^0, x_2^1, x_3^0, \dots, x_n^0) \succ (x_1^0, x_2^0, x_3^1, x_4^0, \dots, x_n^0) \succ \dots \succ (x_1^0, \dots, x_{n-1}^0, x_n^1) \succ x^0 = (x_1^0, \dots, x_n^0)$, where \succ means "is preferred or

indifferent to.” To provide a base scale unit, set $u_1(x_1^1) = 1$. Then $u_i(x_i^1) = \alpha_i$ when $(x_1^0, \dots, x_{i-1}^0, x_i^1, x_{i+1}^0, \dots, x_n^0)$ is indifferent to the gamble that gives $(x_1^1, x_2^0, \dots, x_n^0)$ with probability α_i and x^0 with probability $1 - \alpha_i$. Each u_i , which is specified by

$$u_i(x_i) = u(x_1^0, \dots, x_{i-1}^0, x_i, x_{i+1}^0, \dots, x_n^0) \quad \text{for all } x_i \in X_i, \quad (7.6)$$

can then be filled out, either separately or by the use of tradeoff curves or by some other method. The resultant u_i are then in the form required by (7.4). The same result is obtained in the context of (7.5) if we set $u'_i(x_i^1) = 1$ and $u'_i(x_i^0) = 0$ for all i and let $w_1 = 1$ and $w_i = \alpha_i$ for each $i > 1$, with $u_i = w_i u'_i$. Because distortions of additivity or value independence are most likely to occur for extreme values of the attributes, it may be advisable to use x_i^0 and x_i^1 values that are not close to the worst and best attribute values (if such exist) when additivity is being used as an approximation for a more complex state of affairs.

7.3.2 INTERDEPENDENT ADDITIVITY

When the attributes are not value independent, there may still be a form of value independence among subsets of attributes that may or may not overlap. For example, if $n = 3$ and if $p \sim q$ whenever the marginal gambles of p and q on $X_1 \times X_2$ are equal and the marginal gambles of p and q on $X_2 \times X_3$ are equal, then u can be written as

$$u(x_1, x_2, x_3) = u_{12}(x_1, x_2) + u_{23}(x_2, x_3).$$

Although this interdependent additive form is not as simple as (7.4), it does allow some simplification in the assessment of u .

To generalize the value independence notion, let X_I be the product of the X_i for all i in a nonempty subset I of $\{1, \dots, n\}$, and let P_I be the set of all gambles defined on X_I . For $p \in P$, p_I is the marginal gamble of p on X_I . Thus if $I = \{1, 3\}$ and $n = 3$ with $p(x_1, x_2, x_3) = 1/4$ and $p(y_1, y_2, y_3) = 3/4$, then $p_I(x_1, x_3) = 1/4$ and $p_I(y_1, y_3) = 3/4$. The list of the x_i for $i \in I$ from $x \in X$ is $x_I \in X_I$; hence $p_I(x_I) = 1/4$ and $p_I(y_I) = 3/4$ in the preceding example. Now suppose that $\{I_1, I_2, \dots, I_m\}$ is a collection of nonempty subsets of $\{1, \dots, n\}$ whose union equals $\{1, \dots, n\}$. We then say that the X_{I_j} ($j = 1, \dots, m$) are value independent if and only if $p \sim q$ whenever $p_{I_j} = q_{I_j}$ for $j = 1, \dots, m$. With $\{I_1, \dots, I_m\}$ as described here, it can be proved that there are real-valued functions u_{I_1}, \dots, u_{I_m} on X_{I_1}, \dots, X_{I_m} such that

$$u(x_1, \dots, x_n) = u_{I_1}(x_{I_1}) + \dots + u_{I_m}(x_{I_m}), \quad \text{for all } x \in X, \quad (7.7)$$

if and only if the X_{I_j} are value independent. Fishburn (1967a, 1971) discusses interdependent additivity and proofs of representations such as (7.7).

Even when the attributes are not value independent, (7.7) may hold for a collection $\{I_1, \dots, I_m\}$ of mutually disjoint subsets of $\{1, \dots, n\}$. For example,

the attributes might fall into several natural categories that exhibit value independence among themselves. Then, since the I_j are disjoint, we can work with each u_{I_j} separately to make an overall assessment of u , taking care to scale the several u_{I_j} in a manner consistent with (7.7) when they are considered together.

7.4 UTILITY INDEPENDENCE

At about the same time that value independence was developed as a formal condition in multiattribute utility theory, a related but distinctly different independence concept was being developed and explored by Pollak (1967), Raiffa (1969), Meyer (1970), and Keeney (1968, 1971, 1972b). This alternative concept, which is an extension of independence axioms used in nonprobabilistic additive conjoint measurement (Debreu, 1960; Luce and Tukey, 1964) is concerned with situations in which a preference order over the (marginal) gambles defined on a subset of attributes that is conditioned on fixed values of the other attributes is independent of those fixed values. This type of independence is referred to hereafter as utility independence. For example, with $X = X_1 \times X_2$ and P_1 the set of all gambles on X_1 , let \succ_{x_2} be the decision maker's preference order on P_1 when the value of X_2 is fixed at x_2 . Strictly speaking, $p_1 \succ_{x_2} q_1$ if and only if $p \succ q$ when p_i and q_i are the marginals of p and q on X_i and $p_2(x_2) = q_2(x_2) = 1$. Then X_1 is said to be utility independent of X_2 if $\succ_{x_2} = \succ_{y_2}$ for all x_2 and y_2 in X_2 .

Utility independence always involves a relationship between two complementary subsets of attributes. For $I \subseteq \{1, \dots, n\}$, we let I^c denote the complement of I relative to $\{1, \dots, n\}$, so that I and I^c are mutually disjoint with union $\{1, \dots, n\}$. Consequence $x = (x_1, \dots, x_n)$ will be written as (x_I, x_{I^c}) where $x_I \in X_I$ is the list of x_i for $i \in I$ and $x_{I^c} \in X_{I^c}$ is the list of x_i for $i \in I^c$. If $n = 4$ and $I = \{1, 3\}$ then $(x_I, x_{I^c}) = [(x_1, x_3), (x_2, x_4)]$. When I is a nonempty proper subset of $\{1, \dots, n\}$ and when $w \in X_{I^c}$, we define \succ_w on P_I by

$$p_I \succ_w q_I \quad \text{if and only if} \quad p \succ q \quad \text{when} \quad p_{I^c}(w) = q_{I^c}(w) = 1. \quad (7.8)$$

Thus \succ_w is the conditional preference order on P_I , being conditioned on the fixed values of attributes in I^c as denoted by w .

DEFINITION 2 Let I be a nonempty proper subset of $\{1, \dots, n\}$. Then X_I is *utility independent* of X_{I^c} if and only if the conditional orders \succ_w and \succ_z on P_I are identical for every pair of w and z in X_{I^c} .

A few aspects of this definition deserve brief comment. First, if the attributes are value independent, then X_I is utility independent of X_{I^c} for every appropriate I . The converse implication is not true. Second, if X_I is utility independent of X_{I^c} , then X_{I^c} need not be utility independent of X_I . Third, if the X_i are sets of real numbers and if preferences on the consequences increase monotonically in each

attribute, it does not follow that any X_I is utility independent of its complementary X_{I^c} . The reason for this is that utility independence involves orderings on gambles and not just on consequences. However, if the conditional preference orders on X_I are not identical for any two w and z in X_{I^c} , then X_I cannot be utility independent of X_{I^c} . For example, in the wine–beef–fish example cited above, X_I cannot be utility independent of X_{I^c} if I includes the beverage attribute and I^c includes the main course attribute since a reversal in wine preferences occurs when the main course is changed from beef to fish.

There is, however, a generalized notion of utility independence that can accommodate reversals in conditional preferences to a limited extent. Its definition, based on work by Fishburn (1974) and Fishburn and Keeney (1974, 1975), uses the notions of dual and empty binary relations as defined just before Theorem 2.

DEFINITION 3 Let I be a nonempty proper subset of $\{1, \dots, n\}$, and let w be any element in X_{I^c} for which \succ_w on P_I is not empty. Then X_I is *generalized utility independent* of X_{I^c} if and only if \succ_z on P_I equals one of \succ_w , \succ_w^* and \emptyset for each $z \in X_{I^c}$.

The effect of utility independence or of generalized utility independence on u follows immediately from Theorem 2 when P and X are replaced by P_I and X_I .

THEOREM 4 Suppose X_I is generalized utility independent of X_{I^c} , and w^0 is a fixed element in X_{I^c} with $\succ_{w^0} \neq \emptyset$. Then there are real-valued functions f and g on X_{I^c} such that

$$u(x_I, w) = f(w) + g(w)u(x_I, w^0) \text{ for all } x_I \in X_I \text{ and all } w \in X_{I^c},$$

with $f(w^0) = 0$, $g(w^0) = 1$, $g(w) > 0$ if $\succ_w = \succ_{w^0}$, $g(w) = 0$ if $\succ_w = \emptyset$, and $g(w) < 0$ if $\succ_w = \succ_{w^0}^*$. Moreover, if X_I is utility independent of X_{I^c} then $g(w) > 0$ for all $w \in X_{I^c}$.

The three cases of \succ_w equal to \succ_{w^0} , \emptyset , and $\succ_{w^0}^*$ correspond respectively to $u(\cdot, w)$ being a positive, null, and negative affine transformation of $u(\cdot, w^0)$. Under generalized utility independence, the conditional utility functions $u(\cdot, w)$ on X_I are all related to one another by affine transformations.

7.4.1 COMBINATIONS OF UTILITY INDEPENDENCE

Theorem 4 is used as a point of departure for examining the effects on u of combinations of utility independence for different ordered pairs of complementary attribute sets. Such examinations have been made by Pollak (1967), Keeney (1968, 1971, 1972b, 1974), Raiffa (1969), and Meyer (1970). Combinations of generalized utility independence relations have been examined by Fishburn (1974) and Fishburn and Keeney (1974, 1975). Three of the many results obtained are described here.

Generalized utility independence is used in each case because the utility independence conclusions are special cases of the generalized conclusions.

Our first result shows what happens when X_I is generalized utility independent of X_{I^c} and X_{I^c} is generalized utility independent of X_I .

THEOREM 5 Suppose I is a nonempty proper subset of $\{1, \dots, n\}$ and each of X_I and X_{I^c} is generalized utility independent of the other. Let u be any function on X which satisfies (7.1), and let $y^0, y^1 \in X_I$ and $w^0, w^1 \in X_{I^c}$ be any elements for which $u(y^0, w^1) \neq u(y^0, w^0)$ and $u(y^1, w^0) \neq u(y^0, w^0)$. Then

$$u(x_I, x_{I^c}) = k_1[u(x_I, w^0) + u(y^0, x_{I^c})] + k_2u(x_I, w^0)u(y^0, x_{I^c}) + k_3 \quad (7.9)$$

for all $x_I \in X_I$ and all $x_{I^c} \in X_{I^c}$ where, with

$$k = 1/\{[u(y^0, w^0) - u(y^0, w^1)][u(y^0, w^0) - u(y^1, w^0)]\},$$

the constants in (7.9) are specified by

$$k_1 = k[u(y^1, w^0)u(y^0, w^1) - u(y^0, w^0)u(y^1, w^1)],$$

$$k_2 = k[u(y^0, w^0) + u(y^1, w^1) - u(y^1, w^0) - u(y^0, w^1)],$$

$$k_3 = -k_1u(y^0, w^0).$$

When (7.9) holds, u on X is completely specified by the indicated form with determination of the conditional utility functions $u(\cdot, w^0)$ on X_I and $u(y^0, \cdot)$ on X_{I^c} along with $u(y^1, w^1)$. If

$$u(y^0, w^0) + u(y^1, w^1) = u(y^1, w^0) + u(y^0, w^1), \quad (7.10)$$

then $k_1 = 1$, $k_2 = 0$ and (7.9) reduces to the additive form $u(x_I, x_{I^c}) = u(x_I, w^0) + u(y^0, x_{I^c}) - u(y^0, w^0)$. In other words, the hypotheses of Theorem 5 in conjunction with (7.10) imply that I and I^c are value independent. On the other hand, if (7.10) is false, so that $k_2 \neq 0$, then (7.9) can be written in multiplicative form as

$$u(x_I, x_{I^c}) + \frac{k_1}{k_2} = k_2 \left[u(x_I, w^0) + \frac{k_1}{k_2} \right] \left[u(y^0, x_{I^c}) + \frac{k_1}{k_2} \right], \quad (7.11)$$

since $k_3 - k_1^2/k_2 = -k_1/k_2$. Moreover, if u is scaled so that $u(y^0, w^0) = 0$, then $k_1 = 1$, $k_3 = 0$ and (7.9) becomes

$$u(x_I, x_{I^c}) = u(x_I, w^0) + u(y^0, x_{I^c}) + k_2u(x_I, w^0)u(y^0, x_{I^c}),$$

with $k_2 = [u(y^1, w^1) - u(y^0, w^1) - u(y^1, w^0)]/[u(y^0, w^1)u(y^1, w^0)]$; and, when $k_2 \neq 0$, (7.11) can be rewritten as

$$k_2u(x_I, x_{I^c}) + 1 = [k_2u(x_I, w^0) + 1][k_2u(y^0, x_{I^c}) + 1]. \quad (7.12)$$

The next two theorems, which are proved in Fishburn and Keeney (1975), are concerned with the ability to express u as combinations of one conditional single-attribute utility function for each of the n attributes. To simplify the combinatorial

expressions for u , we shall set an origin for u as in the sentence following (7.11). In particular, (7.6) will be used for u_i along with $u(x_1^0, \dots, x_n^0) = 0$.

Three sets of nonempty subsets of $\{1, \dots, n\}$ will be used in the theorems, namely,

$$I(1) = \{\{1, 2, \dots, n-1\}, \{1, \dots, n-2, n\}, \{1, \dots, n-3, n-1, n\}, \dots, \{1, 3, 4, \dots, n\}\},$$

$$I(2) = \{\{1, 2\}, \{1, 3\}, \dots, \{1, n\}\},$$

$$I(3) = \{\{1\}, \{2\}, \dots, \{n\}\}.$$

Since the $I \in I(3)$ involve only one attribute, these sets are probably easier to check for utility independence or generalized utility independence than are the two-attribute sets in $I(2)$ or the $(n-1)$ -attribute sets in $I(1)$.

THEOREM 6 Suppose $n > 3$ and X_I is generalized utility independent of X_{I^c} either for all $I \in I(1)$ or for all $I \in I(2)$. Let $x^0, x^1 \in X$ be chosen so that $u(x_1^0, x_2^0, \dots, x_n^0) \neq u(x^0)$ and $u(x_1^1, x_2^0, \dots, x_n^0) \neq u(x^0)$, set $u(x^0) = 0$, define K by

$$K = \frac{u(x^1) - u(x_1^0, x_2^1, \dots, x_n^1) - u(x_1^1, x_2^0, \dots, x_n^0)}{u(x_1^0, x_2^1, \dots, x_n^1)u(x_1^1, x_2^0, \dots, x_n^0)},$$

and let u_1, \dots, u_n be defined by (7.6). If $K = 0$, then the attributes are value independent and (7.4) holds; if $K \neq 0$, then

$$Ku(x) + 1 = [Ku_1(x_1) + 1] [Ku_2(x_2) + 1] \dots [Ku_n(x_n) + 1] \quad \text{for all } x \in X. \quad (7.13)$$

The latter form is, of course, a multiplicative form. If $K > 0$, then the positive affine transformation $v = Ku + 1$ with $v_i = Ku_i + 1$ gives $v(x) = v_1(x_1)v_2(x_2) \dots v_n(x_n)$ for (7.13) with $v(x^0) = v_1(x_1^0) = \dots = v_n(x_n^0) = 1$. If $K < 0$, then the positive affine transformation $w = -[Ku + 1]$ with $w_i = -[Ku_i + 1]$ gives $w(x) = (-1)^{n+1}w_1(x_1)w_2(x_2) \dots w_n(x_n)$ for (7.13) with $w(x^0) = w_1(x_1^0) = \dots = w_n(x_n^0) = -1$.

In distinction to the additive and multiplicative forms for u in Theorem 6, the form given by (7.14) or (7.15) in the next theorem is referred to as a quasiadditive utility function.

THEOREM 7 Suppose that $n > 3$, X_I is generalized utility independent of X_{I^c} for all $I \in I(3)$, and there are consequences $x^0, x^1 \in X$ such that $u(x_1^0, \dots, x_{i-1}^0, x_i^1, x_{i+1}^0, \dots, x_n^0) \neq u(x^0)$ for $i = 1, \dots, n$. Set $u(x^0) = 0$, define c_i by

$$c_i = \frac{1}{u(x_1^0, \dots, x_{i-1}^0, x_i^1, x_{i+1}^0, \dots, x_n^0)} \quad i = 1, \dots, n,$$

let u_1, \dots, u_n be defined by (7.6), and let

$$\begin{aligned} U_i(x_i, 1) &= c_i u_i(x_i) && \text{for all } x_i \in X_i, i = 1, \dots, n; \\ U_i(x_i, 0) &= 1 - c_i u_i(x_i) && \text{for all } x_i \in X_i, i = 1, \dots, n. \end{aligned}$$

Then

$$u(x) = \sum_{\substack{(\alpha_1, \dots, \alpha_n) \\ \in \{0, 1\}^n}} U_1(x_1, \alpha_1) \dots U_n(x_n, \alpha_n) u(x_1^{\alpha_1}, \dots, x_n^{\alpha_n}) \quad (7.14)$$

for all $x \in X$; equivalently,

$$u(x) = \sum_{\substack{\{(i_1, \dots, i_r): 1 \leq r \leq n \\ \text{and } 1 \leq i_1 < \dots < i_r \leq n\}}} S(i_1, \dots, i_r) c_{i_1} \dots c_{i_r} u_{i_1}(x_{i_1}) \dots u_{i_r}(x_{i_r}), \quad (7.15)$$

for all $x \in X$, where

$$S(i_1, \dots, i_r) = \sum_{\substack{(\alpha_1, \dots, \alpha_n) \in \{0, 1\}^n \\ \text{such that } \alpha_i = 0 \\ \text{for all } i \in \{i_1, \dots, i_r\}}} (-1)^{r + \sum_{i=1}^n \alpha_i} u(x_1^{\alpha_1}, \dots, x_n^{\alpha_n}). \quad (7.16)$$

For $n = 3$, (7.14) in expanded form is

$$\begin{aligned} u(x_1, x_2, x_3) &= c_1 c_2 c_3 u_1(x_1) u_2(x_2) u_3(x_3) u(x_1^1, x_2^1, x_3^1) \\ &+ c_1 c_2 u_1(x_1) u_2(x_2) [1 - c_3 u_3(x_3)] u(x_1^1, x_2^1, x_3^0) \\ &+ c_1 c_3 u_1(x_1) u_3(x_3) [1 - c_2 u_2(x_2)] u(x_1^1, x_2^0, x_3^1) \\ &+ c_2 c_3 u_2(x_2) u_3(x_3) [1 - c_1 u_1(x_1)] u(x_1^0, x_2^1, x_3^1) \\ &+ c_1 u_1(x_1) [1 - c_2 u_2(x_2)] [1 - c_3 u_3(x_3)] u(x_1^1, x_2^0, x_3^0) \\ &+ c_2 u_2(x_2) [1 - c_1 u_1(x_1)] [1 - c_3 u_3(x_3)] u(x_1^0, x_2^1, x_3^0) \\ &+ c_3 u_3(x_3) [1 - c_1 u_1(x_1)] [1 - c_2 u_2(x_2)] u(x_1^0, x_2^0, x_3^1), \end{aligned}$$

and (7.15) is

$$\begin{aligned} u(x_1, x_2, x_3) &= u_1(x_1) + u_2(x_2) + u_3(x_3) \\ &+ c_1 c_2 [u(x_1^1, x_2^1, x_3^0) - u(x_1^1, x_2^0, x_3^0) - u(x_1^0, x_2^1, x_3^0)] u_1(x_1) u_2(x_2) \\ &+ c_1 c_3 [u(x_1^1, x_2^0, x_3^1) - u(x_1^1, x_2^0, x_3^0) - u(x_1^0, x_2^0, x_3^1)] u_1(x_1) u_3(x_3) \\ &+ c_2 c_3 [u(x_1^0, x_2^1, x_3^1) - u(x_1^0, x_2^1, x_3^0) - u(x_1^0, x_2^0, x_3^1)] u_2(x_2) u_3(x_3) \\ &+ c_1 c_2 c_3 [u(x_1^1, x_2^1, x_3^1) - u(x_1^1, x_2^1, x_3^0) - u(x_1^1, x_2^0, x_3^1) - u(x_1^0, x_2^1, x_3^1) \\ &+ u(x_1^1, x_2^0, x_3^0) + u(x_1^0, x_2^1, x_3^0) + u(x_1^0, x_2^0, x_3^1)] u_1(x_1) u_2(x_2) u_3(x_3), \end{aligned}$$

where $S(i) c_i = (-1)^2 u(x_1^0, \dots, x_{i-1}^0, x_i^1, x_{i+1}^0, \dots, x_n^0) c_i = 1$ for each i . If the attributes are value independent, then $S(i_1, \dots, i_r) = 0$ whenever $r \geq 2$, and hence u reduces to the additive form.

As noted earlier, the forms of u in Theorems 6 and 7 require evaluation of one conditional single-attribute utility function u_i for each attribute. In addition, (7.13) requires evaluation of $u(x^1)$ and $u(x_1^0, x_2^1, \dots, x_n^1)$, and (7.14) or (7.15) requires evaluation of $u(x_1^{\alpha_1}, \dots, x_n^{\alpha_n})$ for all $(\alpha_1, \dots, \alpha_n) \in \{0, 1\}^n$.

7.4.2 VERIFICATION OF UTILITY INDEPENDENCE

The usefulness of results like Theorems 6 and 7 in any specific situation depends on whether the presumed independence conditions hold for that situation. Techniques for judging the validity of utility independence assertions, and for structuring attributes so that they will exhibit utility independence, are discussed by Raiffa (1969), de Neufville and Keeney (1972), Keeney (1972a, 1973, 1974), Keeney and Nair (1974), and Sicherman (1975). These papers also discuss utility assessment techniques in the independence context and provide specific examples of the application of these techniques.

There are two important facets of utility independence verification that are worthy of comment. The first of these concerns the ability to deduce a utility independence conclusion from a weaker independence condition involving the same X_I along with a utility independence condition for a different X_I . We shall use the following definitions, which do not involve gambles.

DEFINITION 4 Let I be a nonempty proper subset of $\{1, \dots, n\}$. Then X_I is *preference independent* of X_{I^c} if and only if the conditional orders \succ_w and \succ_z on X_I are identical for every $w, z \in X_{I^c}$. X_I is *weak indifference independent* of X_{I^c} if and only if there is a $w \in X_{I^c}$ such that, for all $x_I, x'_I \in X_I$ and all $z \in X_{I^c}$, $(x_I, z) \sim (x'_I, z)$ whenever $(x_I, w) \sim (x'_I, w)$.

Preference independence is the typical type of independence that is used in non-probabilistic additive conjoint measurement. Weak indifference independence is an even weaker independence concept that is implied by preference independence. As remarked earlier, X_I is not necessarily utility independent of X_{I^c} when X_I is preference independent (or weak indifference independent) of X_{I^c} . However, the following theorem, derived by Keeney (1974) and Fishburn and Keeney (1974), shows that utility independence can be implied by a weaker independence condition when certain other conditions hold.

THEOREM 8 Suppose that I_1, I_2 , and I_3 are three nonempty and mutually exclusive subsets of $\{1, \dots, n\}$ whose union equals $\{1, \dots, n\}$, that each X_{I_i} is a convex subset of a finite-dimensional Euclidean space, that u on X is continuous, that X_{I_1} is utility independent of $X_{I_2 \cup I_3}$, and that $X_{I_1 \cup I_2}$ is weak indifference independent of X_{I_3} . Then $X_{I_1 \cup I_2}$ is utility independent of X_{I_3} .

The usefulness of this result can be shown with regard to Theorem 6. Suppose the X_i have the structure presumed by Theorem 8, that u is continuous, that X_1 is

utility independent of $X_{\{2, \dots, n\}}$, and that $X_{\{1, i\}}$ is weak indifference independent (or preference independent) of $X_{\{1, i\}^c}$ for each $i > 1$. Given $n \geq 3$, it then follows from Theorem 8 that X_I is utility independent of X_{I^c} for each $I \in I(2)$. Consequently, Theorem 6 implies that u can be written in either an additive or multiplicative form. Other results like Theorem 8 are given by Fishburn (1974).

The simplest way to show that X_I is *not* utility independent of X_{I^c} – if that is the case – when X_I is preference independent of X_{I^c} and X_I contains a large number of elements is as follows: First, select a relatively desirable element y^1 and a relatively undesirable element y^0 in X_I , and select a relatively desirable element w^1 and a relatively undesirable element w^0 in X_{I^c} , with $(y^1, w^1) \succ \{(y^0, w^1), (y^1, w^0)\} \succ (y^0, w^0)$. Next, estimate an element $y^* \in X_I$ such that (y^*, w^0) is indifferent to the 50–50 gamble between (y^0, w^0) and (y^1, w^0) . Now, if X_I is utility independent of X_{I^c} then it must also be true that (y^*, w^1) is indifferent to the 50–50 gamble between (y^0, w^1) and (y^1, w^1) . This might be the case. However, if the comparative attractiveness of a gamble in P_I depends on the fixed value of X_{I^c} (either w^0 or w^1), then indifference may well fail. For example, with the improved element from X_{I^c} in the second instance, the decision maker might alter his risk attitude toward X_I and become less conservative, as revealed by a preference for the 50–50 gamble between (y^0, w^1) and (y^1, w^1) over the sure-thing consequence (y^*, w^1) . On the other hand, he might become more conservative and prefer (y^*, w^1) to the 50–50 gamble based on w^1 . In either case, a violation of utility independence is observed.

7.5 CONDITIONAL RISK ATTITUDES AND BILATERAL INDEPENDENCE

Although utility independence is violated when a decision maker's risk attitude toward X_I varies as changes occur in the conditioning element from X_{I^c} , another independence concept can deal with such variations, provided they are fairly regular in form. This new independence concept, introduced by Fishburn (1973, 1974), utilizes conditional orders on P_I that are based on two conditioning elements from X_{I^c} rather than on one conditioning element as in utility independence, and its resultant form for the utility function employs two conditional utility functions on X_I and two on X_{I^c} . Moreover, like value independence, but unlike utility independence, it is a symmetric independence concept in the sense that if X_I is independent of X_{I^c} , then X_{I^c} is independent of X_I . For these reasons I shall refer to it as bilateral independence, although Farquhar (1974), for geometric reasons, has called it diagonal independence. Like utility independence, bilateral independence has a "pure" and a "generalized" form. I shall use the generalized form in this section and refer to it simply as bilateral independence.

Let I be a nonempty proper subset of $\{1, \dots, n\}$. Given $p_I \in P_I$ and $w \in X_{I^c}$, let (p_I, w) denote the gamble in P that has p_I as its marginal on X_I and whose

marginal on X_{I^c} assigns probability 1 to w . Thus, if $n = 3$ and $I = \{1, 2\}$ with $p_I(x_1, x_2) = 0.1$ and $p_I(y_1, y_2) = 0.9$, then (p_I, x_3) assigns probability 0.1 to (x_1, x_2, x_3) and probability 0.9 to (y_1, y_2, x_3) . The expression $\lambda(p_I, w) + (1 - \lambda)(q_I, z)$ with $0 \leq \lambda \leq 1$, $p_I, q_I \in P_I$ and $w, z \in X_{I^c}$, is the convex combination of gambles $(p_I, w), (q_I, z) \in P$ as indicated at the beginning of section 7.2. Similar definitions apply to gambles in P of the form (p_{I^c}, y) where $p_{I^c} \in P_{I^c}$ and $y \in X_I$.

The doubly conditional preference orders on P_I that are used to define bilateral independence are based on 50–50 convex combinations as follows:

$$p_I \succ_{wz} q_I \text{ iff } \frac{1}{2}(p_I, w) + \frac{1}{2}(q_I, z) \succ \frac{1}{2}(p_I, z) + \frac{1}{2}(q_I, w), \quad (7.17)$$

with $p_I, q_I \in P_I$ and $w, z \in X_{I^c}$. If $w = z$ in (7.17), then, since the two gambles in the right part of (7.17) are identical, we must have $p_I \sim_{ww} q_I$ for all $p_I, q_I \in P_I$, so that $\succ_{ww} = \emptyset$ is automatic. Moreover, if $\succ_{wz} = \emptyset$ for all $w, z \in X_{I^c}$ then it must be true that X_I and X_{I^c} are value independent.

Intuitively speaking, $p_I \succ_{wz} q_I$ indicates that the decision maker finds the 50–50 gamble between the pairings (p_I, w) and (q_I, z) more attractive than the 50–50 gamble between the opposite pairings (p_I, z) and (q_I, w) . If one of the fixed conditioning elements is changed, say from w to w' , then the indicated preference might also change. Such changes are allowed for by (generalized) bilateral independence, but only to the extent indicated by the following definition. Since (7.17) says that $p_I \succ_{wz} q_I$ if and only if $q_I \succ_{zw} p_I$, or $\succ_{wz}^* = \succ_{zw}$, we shall use \succ_{zw} to indicate the dual of \succ_{wz} in the definition.

DEFINITION 5 Let I be a nonempty proper subset of $\{1, \dots, n\}$. Then X_I is *bilaterally independent* of X_{I^c} if and only if either $\succ_{wz} = \emptyset$ for all $w, z \in X_{I^c}$, or there exist $w, z \in X_{I^c}$ such that $\succ_{wz} \neq \emptyset$ and, for all $w' \in X_{I^c}$, $\succ_{w'z} \in \{\succ_{wz}, \succ_{zw}, \emptyset\}$.

Fishburn (1974) showed that X_I is bilaterally independent of X_{I^c} if X_I and X_{I^c} are value independent ($\succ_{wz} = \emptyset$ for all $w, z \in X_{I^c}$), or if X_I is generalized utility independent of X_{I^c} , or if X_{I^c} is generalized utility independent of X_I . Moreover, X_I is bilaterally independent of X_{I^c} if, and only if, X_{I^c} is bilaterally independent of X_I . Because of this symmetry, it is permissible to say that X_I and X_{I^c} are bilaterally independent.

When X_I and X_{I^c} are bilaterally independent, every two nonempty doubly conditioned preference orders on P_I must either be identical or be duals of one another regardless of whether the conditioning elements for the two orders overlap. This follows easily from the next theorem.

THEOREM 9 Suppose I is a nonempty proper subset of $\{1, \dots, n\}$. Then X_I is bilaterally independent of X_{I^c} if and only if there are real-valued functions

f_1 and g_1 on X_I and real-valued functions f_2 and g_2 on X_{I^c} such that

$$u(x) = f_1(x_I) + f_2(x_{I^c}) + g_1(x_I)g_2(x_{I^c}) \quad \text{for all } x \in X. \quad (7.18)$$

In particular, if X_I is bilaterally independent of X_{I^c} , if X_I and X_{I^c} are not value independent, if $y^0, y^1 \in X_I$ and $w^0, w^1 \in X_{I^c}$ are such that $u(y^0, w^0) + u(y^1, w^1) \neq u(y^0, w^1) + u(y^1, w^0)$, and if u is scaled so that $u(y^0, w^0) = 0$, then

$$u(x) = u(x_I, w^0) + u(y^0, x_{I^c}) + \frac{[u(x_I, w^1) - u(x_I, w^0) - u(y^0, w^1)] [u(y^1, x_{I^c}) - u(y^0, x_{I^c}) - u(y^1, w^0)]}{[u(y^1, w^1) - u(y^0, w^1) - u(y^1, w^0)]} \quad (7.19)$$

for all $x \in X$.

The symmetry of bilateral independence is obvious from (7.18). The particular form of (7.18) expressed by (7.19) shows that the general bilateral representation depends on two conditional utility functions $u(\cdot, w^0)$ and $u(\cdot, w^1)$ on X_I and two conditional utility functions $u(y^0, \cdot)$ and $u(y^1, \cdot)$ on X_{I^c} . The ability of bilateral independence to reflect variations in conditional risk attitude can be seen from either (7.18) or (7.19). A specific example of this ability is given by Fishburn (1973) for two-period income streams.

Next, the effect of bilateral independence between X_i and $X_{\{i\}^c}$ for each $i \in \{1, \dots, n\}$ is observed.

THEOREM 10 X_i and $X_{\{i\}^c}$ are bilaterally independent for $i = 1, \dots, n$ if and only if there are real-valued functions f_i and g_i on X_i for $i = 1, \dots, n$ and constants $c(i_1, \dots, i_r)$ such that

$$u(x_1, \dots, x_n) = \sum_{i=1}^n f_i(x_i) + \sum_{\substack{\{(i_1, \dots, i_r): 2 \leq r \leq n \\ \text{and } 1 \leq i_1 < \dots < i_n \leq n\}}} c(i_1, \dots, i_r) g_{i_1}(x_{i_1}) \dots g_{i_r}(x_{i_r}) \quad (7.20)$$

for all $x \in X$. In particular, if X_i is bilaterally independent of $X_{\{i\}^c}$ for all i , if no X_i and $X_{\{i\}^c}$ are value independent, if $x^0, x^1 \in X$ are such that $u(x^0) + u(x^1) \neq u(x_1^0, \dots, x_{i-1}^0, x_i^1, x_{i+1}^0, \dots, x_n^0) + u(x_1^1, \dots, x_{i-1}^1, x_i^0, x_{i+1}^1, \dots, x_n^1)$ for $i = 1, \dots, n$, and if u is scaled so that $u(x^0) = 0$, then (7.20) hold for all $x \in X$ with

$$f_i(x_i) = u_i^0(x_i) \\ g_i(x_i) = \frac{u_i^1(x_i) - u_i^0(x_i) - u_i^1(x_i^0)}{u_i^1(x_i^1) - u_i^0(x_i^1) - u_i^1(x_i^0)}$$

$$c(i_1, \dots, i_r) = S(i_1, \dots, i_r), \quad \text{as in (7.16),}$$

where

$$u_i^0(x_i) = u(x_1^0, \dots, x_{i-1}^0, x_i, x_{i+1}^0, \dots, x_n^0) \\ u_i^1(x_i) = u(x_1^1, \dots, x_{i-1}^1, x_i, x_{i+1}^1, \dots, x_n^1)$$

for all $x_i \in X_i$ and all i .

A proof of Theorem 10 is given in Fishburn (1973). As indicated in the latter part of the theorem, two conditional single-attribute utility functions are used for each attribute when there is no value independence.

7.6 FRACTIONAL INDEPENDENCE

The last of the independence concepts to be considered here is a general scheme for generating independence conditions developed by Farquhar (1974, 1975). Special conditions, such as generalized utility independence and bilateral independence, arise naturally within this scheme. For expository purposes, I shall focus on ways in which X_i might be independent of $X_{\{i\}^c}$.

Farquhar's scheme uses preference orders on P_i that are conditioned on from 1 to 2^{n-1} elements from $X_{\{i\}^c}$. The conditioning elements come from $\{(x_1^{\alpha_1}, \dots, x_{i-1}^{\alpha_{i-1}}, x_{i+1}^{\alpha_{i+1}}, \dots, x_n^{\alpha_n}) : \alpha_j \in \{0, 1\} \text{ for each } j \neq i\}$, where x_j^0 and x_j^1 can be any values of X_j for each $j \neq i$. Generalized utility independence uses the conditioning element $x_{\{i\}^c}^1$, and bilateral independence uses $x_{\{i\}^c}^0$ and $x_{\{i\}^c}^1$. Conditional orders on P_i are based on primal fractions.

A *primal fraction* F_i is defined as a subset of $\{0, 1\}^n$ that contains $(1, \dots, 1)$ and does not contain $(\alpha_1, \dots, \alpha_{i-1}, 1 - \alpha_i, \alpha_{i+1}, \dots, \alpha_n)$ whenever it contains $(\alpha_1, \dots, \alpha_i, \dots, \alpha_n)$. Thus $|F_i|$, the number of n -tuples in F_i , can range from 1 to 2^{n-1} . With respect to $\{x_j^0, x_j^1\}$ for each $j \neq i$ and with respect to F_i , the conditioning elements for an order on P_i are identified by the set

$$F_i[x^0, x^1] = \{(x_1^{\alpha_1}, \dots, x_{i-1}^{\alpha_{i-1}}, x_{i+1}^{\alpha_{i+1}}, \dots, x_n^{\alpha_n}) :$$

$$(\alpha_1, \dots, \alpha_{i-1}, 0, \alpha_{i+1}, \dots, \alpha_n) \in F_i \text{ or } (\alpha_1, \dots, \alpha_{i-1}, 1, \alpha_{i+1}, \dots, \alpha_n) \in F_i\},$$

and the order on P_i conditioned on $F_i[x^0, x^1]$ is defined by

$$p_i^1 \succ_{F_i[x^0, x^1]} p_i^0$$

if and only if

$$\sum_{F_i} \frac{1}{|F_i|} (x_1^{\alpha_1}, \dots, p_i^{\alpha_i}, \dots, x_n^{\alpha_n}) \succ \sum_{F_i} \frac{1}{|F_i|} (x_1^{\alpha_1}, \dots, p_i^{1-\alpha_i}, \dots, x_n^{\alpha_n}) \quad (7.21)$$

for all $p_i^1, p_i^0 \in P_i$. Here $(x_1^{\alpha_1}, \dots, p_i^{\alpha_i}, \dots, x_n^{\alpha_n}) \in P$ has marginal $p_i^{\alpha_i}$ on X_i and assigns probability 1 to each $x_j^{\alpha_j}$ for $j \neq i$. Letting $p_i^1 = p_i$ and $p_i^0 = q_i$, (7.21) for $F_i = \{(1, \dots, 1)\}$ is

$$p_i \succ_{F_i[x^0, x^1]} q_i \quad \text{iff} \quad (p_i, x_{\{i\}^c}^1) \succ (q_i, x_{\{i\}^c}^1),$$

which compares to (7.8), and (7.21) for $F_i = \{(1, \dots, 1), (0, \dots, 0)\}$ is

$$p_i \succ_{F_i[x^0, x^1]} q_i$$

if and only if

$$\frac{1}{2}(p_i, x_{\{i\}^c}^1) + \frac{1}{2}(q_i, x_{\{i\}^c}^0) \succ \frac{1}{2}(q_i, x_{\{i\}^c}^1) + \frac{1}{2}(p_i, x_{\{i\}^c}^0),$$

which compares to (7.17). These are the only two types of orders generated by (7.21) when $n = 2$. When $n > 2$, (7.21) yields many other types of conditional orders. One of these is based on Farquhar's "quasi-pyramid" primal fraction

$$Q_i = \{(1, \dots, 1)\} \cup \{(\alpha_1, \dots, \alpha_n) : \alpha_i = 0 \text{ and } \sum \alpha_j = 1\}, \quad (7.22)$$

with $|Q_i| = n$. For $n = 3$ and $i = 1$, (7.21) gives

$$p_1 \succ_{Q_1[x^0, x^1]} q_1$$

if and only if

$$\begin{aligned} & \frac{1}{3}(p_1, x_2^1, x_3^1) + \frac{1}{3}(q_1, x_2^0, x_3^1) + \frac{1}{3}(q_1, x_2^1, x_3^0) \\ & \succ \frac{1}{3}(q_1, x_2^1, x_3^1) + \frac{1}{3}(p_1, x_2^0, x_3^1) + \frac{1}{3}(p_1, x_2^1, x_3^0). \end{aligned}$$

DEFINITION 6 Let F_i be a primal fraction in $\{0, 1\}^n$. Then X_i is *generalized fractionally independent of $X_{\{i\}^c}$ for F_i* if and only if either $\succ_{F_i[x^0, x^1]} = \emptyset$ for all $x_{\{i\}^c}^0, x_{\{i\}^c}^1 \in X_{\{i\}^c}$, or there exist $x_{\{i\}^c}^0, x_{\{i\}^c}^1 \in X_{\{i\}^c}$ such that $\succ_{F_i[x^0, x^1]} \neq \emptyset$ and, for all $w_{\{i\}^c} \in X_{\{i\}^c}$, $\succ_{F_i[x^0, w^1]} \in \{\succ_{F_i[x^0, x^1]}, \succ_{F_i[x^0, x^1]}^*, \emptyset\}$.

This definition is patterned after Definitions 3 and 5 for generalized utility independence and bilateral independence and is consistent with those definitions.

Farquhar's main utility decomposition theorem, which is Theorem 3.2 in Farquhar (1974) and Theorem 4 in Farquhar (1975), indicates the special form for u that results when X_i is generalized fractionally independent of $X_{\{i\}^c}$ for F_i , for $i = 1, \dots, n$. Theorems 7 and 10 above are special cases of his general theorem. Both of these use the same F_i for each i ($\{(1, \dots, 1)\}$ for Theorem 7; $\{(1, \dots, 1), (0, \dots, 0)\}$ for Theorem 10), but his general theorem allows different F_i for the different i . An example of this is given by the quasi-pyramid form, with Q_i the primal fraction for each i as defined by (7.22). When X_i is generalized fractionally independent of $X_{\{i\}^c}$ for Q_i , $i = 1, \dots, n$ with $n \geq 3$, and when several other minor conditions hold, u can be written as

$$\begin{aligned} u(x) = & \sum_{i=1}^n c_i u_i(x_i) + \sum_{\{(i,j): i < j\}} c_{ij} u_{ij}(x_i, x_j) \\ & + \sum_{\substack{\{(i_1, \dots, i_r): 3 \leq r \leq n \\ \text{and } 1 \leq i_1 < \dots < i_r \leq n\}}} c_{i_1, \dots, i_r} u_{i_1, \dots, i_r}(x_{i_1}, \dots, x_{i_r}). \end{aligned}$$

This form requires assessment of $n(n-1)/2$ two-attribute conditional utility functions u_{ij} . The single-attribute functions u_i are determined by the u_{ij} . Some of the other special forms for u discussed by Farquhar require the assessment of m -attribute conditional utility functions for $2 < m < n$.

7.7 APPROXIMATIONS OF MULTIATTRIBUTE UTILITIES

As is evident from sections 7.5 and 7.6, independence conditions that allow u to be written in terms of conditional utility functions on fewer than n attributes can

become complex. Although some of the more advanced conditions are more likely to hold in practice than simpler conditions such as value independence and utility independence, they are harder to understand and to explain. Moreover, some of the special forms obtained for u require assessment of conditional utility functions defined on two or more attributes, and some feel that it is difficult enough to obtain accurate assessments of conditional single-attribute functions. In addition, even if it were possible to examine all of the independence conditions set forth above, there will surely be situations in which none of them are valid.

Consequently, there is a need to explore the general problem of multiattribute utility assessment in the absence of simplifying independence assumptions. Although there are several approaches to this problem, I shall comment here only on the potential use of ideas in mathematical approximation theory (Cheney, 1966; Lorentz, 1966) for approximating multiattribute utility functions on the basis of conditional single-attribute utility functions.

Let u^* be a real-valued function on $X = X_1 \times X_2 \times \dots \times X_n$ that is intended as an approximation of u . A fairly large class of approximations for u is specified by the multiplicative-additive form

$$u^*(x_1, x_2, \dots, x_n) = \sum_{j=1}^m f_{1j}(x_1)f_{2j}(x_2) \dots f_{nj}(x_n). \quad (7.23)$$

Although other approximating forms could be considered, (7.23) is quite flexible and seems a reasonable basis from which to proceed. Moreover, u^* can be exact in the sense that $u^* \equiv u$ when appropriate independence conditions hold. Each real-valued function f_{ij} on X_i may involve one or more conditional utility functions on X_i , or it may be specified in some way that does not depend directly on u . For example, the additive form would have $m = n$, $f_{ii} = u_i$ and $f_{ij} \equiv 1$ whenever $i \neq j$.

Approximation theory often presumes that the function being approximated is a continuous real-valued function defined on a compact Hausdorff topological space. In our utility theory context this presumption is satisfied if u is continuous and each X_i is a closed and bounded convex subset of a finite-dimensional Euclidean space. Under this presupposition, the "distance" between u and its approximation u^* is frequently measured by the uniform norm $\|u^* - u\|$, where, with $|\dots|$ denoting absolute value,

$$\|u^* - u\| = \sup_{x \in X} |u^*(x) - u(x)|,$$

with the supremum replaced by "max" if u^* is also continuous. Hence $\|u^* - u\|$ gives the maximum difference between u^* and u . Other norms can be used, but the uniform norm is simple and analytically manageable in most situations.

Fishburn (1975) explores the use of the uniform norm for approximations in the form of (7.23) when $n = 2$ and each attribute is a closed interval of real numbers. It is assumed throughout that u on $X_1 \times X_2$ is continuous and takes $X_1 = X_2 = [0, 1]$ for notational convenience. Theorem 11, based on Theorems 2 and 7 in Fishburn (1975), provides an indication of the potential usefulness of simple approximations

for u . The theorem presumes that u is *conservative* (risk averse) on $[0, 1]^2$, which means that u is strictly increasing in each variable and that

$$u(x_1, x_2^*) + u(x_1^*, x_2) > u(x_1, x_2) + u(x_1^*, x_2^*) \tag{7.24}$$

whenever $0 \leq x_1 < x_1^* \leq 1$ and $0 \leq x_2 < x_2^* \leq 1$. The two-period income stream example following (7.4) gives a concrete instance of conservatism. We shall let

$$\Delta = u(1, 0) + u(0, 1) - u(0, 0) - u(1, 1),$$

which is positive according to (7.24), and let

$$\phi_{ij}(x_1, x_2) = (-1)^{i+j} [u(x_1, j) + u(i, x_2) - u(x_1, x_2) - u(i, j)] \text{ for } (i, j) \in \{0, 1\}^2,$$

with $\phi_{ij} \geq 0$, again according to (7.24).

THEOREM 11 Suppose u on $[0, 1]^2$ is continuous and conservative. Given the additive approximation

$$u^*(x_1, x_2) = u(x_1, x_2^0) + u(x_1^0, x_2) - u(x_1^0, x_2^0),$$

where (x_1^0, x_2^0) is a fixed point in $[0, 1]^2$,

$$\|u^* - u\| = \max \{ \phi_{00}(x_1^0, x_2^0), \phi_{11}(x_1^0, x_2^0), \phi_{01}(x_1^0, x_2^0), \phi_{10}(x_1^0, x_2^0) \}$$

and (x_1^0, x_2^0) can be chosen so that $\|u^* - u\| < \Delta/3$; however, it is impossible to have $\|u^* - u\| < \Delta/4$. Alternatively, when u^* is specified by the bilateral approximation [compare (7.19)]

$$u^*(x_1, x_2) = u(x_1, 0) + u(0, x_2) - u(0, 0) + \frac{[u(x_1, 1) - u(x_1, 0) + u(0, 0) - u(0, 1)][u(1, x_2) - u(0, x_2) + u(0, 0) - u(1, 0)]}{-\Delta},$$

then u^* is conservative and $\|u^* - u\| < \Delta/2$, with $\|u^* - u\| = 0$ if and only if X_1 and X_2 are bilaterally independent.

Hence if Δ is small compared to $u(1, 1) - u(0, 0) = \max u(x_1, x_2) - \min u(x_1, x_2)$, then the simple additive form can give a close fit to u although this fit cannot be exact; and, regardless of the size of Δ , the bilateral approximation has the potential of providing a close fit to u that might be exact.

REFERENCES

Allais, M. 1953. Le comportement de l'homme rationnel devant le risque: critique des postulats et axiomes de l'ecole Americaine. *Econometrica*, Vol. 21, pp. 503-546.
 Cheney, E.W. 1966. *Introduction to Approximation Theory*. McGraw-Hill, New York.
 Churchman, C.W., and R.L. Ackoff. 1954. An approximate measure of value. *Operations Research*, Vol. 2, pp. 172-187.

- Debreu, G. 1960. Topological methods in cardinal utility theory. In *Mathematical Methods in the Social Sciences, 1959* (K.J. Arrow, S. Karlin, and P. Suppes, eds.). Stanford University Press, Stanford, California.
- Delbeke, L., and J. Fauville. 1974. An empirical test for Fishburn's additivity axiom. *Acta Psychologica*, Vol. 38, 1–20.
- de Neufville, R., and R.L. Keeney. 1972. Use of decision analysis in airport development for Mexico City. In *Analysis for Public Systems* (A.W. Drake, R.L. Keeney, and P.M. Morse, eds.). MIT Press, Cambridge, Massachusetts.
- Farquhar, P.H. 1974. Fractional hypercube decompositions of multiattribute utility functions. Technical Report No. 222. Department of Operations Research, Cornell University, Ithaca, New York.
- Farquhar, P.H. 1975. A fractional hypercube decomposition theorem for multiattribute utility functions. *Operations Research*, Vol. 23, pp. 941–967.
- Fishburn, P.C. 1965. Independence in utility theory with whole product sets. *Operations Research*, Vol. 13, pp. 28–45.
- Fishburn, P.C. 1967a. Interdependence and additivity in multivariate, unidimensional expected utility theory. *International Economic Review*, Vol. 8, pp. 335–342.
- Fishburn, P.C. 1967b. Methods of estimating additive utilities. *Management Science*, Vol. 13, pp. 435–453.
- Fishburn, P.C. 1970a. Intransitive indifference in preference theory: a survey. *Operations Research*, Vol. 18, pp. 207–228.
- Fishburn, P.C. 1970b. *Utility Theory for Decision Making*. Wiley, New York.
- Fishburn, P.C. 1971. Additive representations of real-valued functions on subsets of product sets. *Journal of Mathematical Psychology*, Vol. 8, pp. 382–388.
- Fishburn, P.C. 1972a. Alternative axiomatizations of one-way expected utility. *Annals of Mathematical Statistics*, Vol. 43, pp. 1648–1651.
- Fishburn, P.C. 1972b. Minimal preferences on lotteries. *Journal of Mathematical Psychology*, Vol. 9, pp. 294–305.
- Fishburn, P.C. 1973. Bernoullian utilities for multiple-factor situations. In *Multiple Criteria Decision Making* (J.L. Cochrane and M. Zeleny, eds.). University of South Carolina Press, Columbia.
- Fishburn, P.C. 1974. Von Neumann–Morgenstern utility functions on two attributes. *Operations Research*, Vol. 22, pp. 35–45.
- Fishburn, P.C. 1975. Approximations of two-attribute utility functions. Mimeographed. The Pennsylvania State University.
- Fishburn, P.C. 1976. Utility independence on subsets of product sets. *Operations Research*, Vol. 24, pp. 245–255.
- Fishburn, P.C., and R.L. Keeney. 1974. Seven independence concepts and continuous multi-attribute utility functions. *Journal of Mathematical Psychology*, Vol. 11, pp. 294–327.
- Fishburn, P.C., and R.L. Keeney. 1975. Generalized utility independence and some implications. *Operations Research*, Vol. 23, pp. 929–940.
- Herstein, I.N., and J. Milnor. 1953. An axiomatic approach to measurable utility. *Econometrica*, Vol. 21, pp. 291–297.
- Jensen, N.E. 1967. An introduction to Bernoullian utility theory. I. Utility functions. *Swedish Journal of Economics*, Vol. 69, pp. 163–183.
- Keeney, R.L. 1968. Quasi-separable utility functions. *Naval Research Logistics Quarterly*, Vol. 15, pp. 551–565.
- Keeney, R.L. 1971. Utility independence and preferences for multiattributed consequences. *Operations Research*, Vol. 19, pp. 875–893.
- Keeney, R.L. 1972a. An illustrated procedure for assessing multiattributed utility functions. *Sloan Management Review*, Vol. 14, pp. 37–50.

- Keeney, R.L. 1972b. Utility functions for multiattributed consequences. *Management Science*, Vol. 18, pp. 276–287.
- Keeney, R.L. 1973. A decision analysis with multiple objectives: the Mexico City airport. *Bell Journal of Economics and Management Science*, Vol. 4, pp. 101–117.
- Keeney, R.L. 1974. Multiplicative utility functions. *Operations Research*, Vol. 22, pp. 22–34.
- Keeney, R.L., and K. Nair. 1974. Decision analysis for the siting of nuclear power plants – the relevance of multiattribute utility theory. Technical Report No. 96. Operations Research Center, Massachusetts Institute of Technology, Cambridge.
- Keeney, R.L., and H. Raiffa. 1976. *Decisions with Multiple Objectives: Preferences and Value Tradeoffs*. John Wiley, New York.
- Lorentz, G.G. 1966. *Approximations of Functions*. Holt, Rinehart and Winston, New York.
- Luce, R.D. 1956. Semiorders and a theory of utility discrimination. *Econometrica*, Vol. 24, pp. 178–191.
- Luce, R.D., and H. Raiffa. 1957. *Games and Decisions*. John Wiley, New York.
- Luce, R.D., and J.W. Tukey. 1964. Simultaneous conjoint measurement: a new type of fundamental measurement. *Journal of Mathematical Psychology*, Vol. 1, pp. 1–27.
- Meyer, R.F. 1970. On the relationship among the utility of assets, the utility of consumption, and investment strategy in an uncertain, but time-invariant world. In *OR 69: Proceedings of the Fifth International Conference on Operational Research* (J. Lawrence, ed.). Tavistock, London.
- Pollak, R.A. 1967. Additive von Neumann–Morgenstern utility functions. *Econometrica*, Vol. 35, pp. 485–494.
- Raiffa, H. 1969. Preferences for multiattributed alternatives. RM-5868-DOT RC. The Rand Corporation, Santa Monica, California.
- Richard, S.F. 1975. Multivariate risk aversion, utility-independence and separable utility functions. *Management Science*, Vol. 22, pp. 12–21.
- Savage, L.J. 1972. *The Foundations of Statistics*. 2nd rev. ed. Dover Publications, New York.
- Sicherman, A. 1975. An interactive computer program for assessing and using multiattribute utility functions. Technical Report No. 111. Operations Research Center, Massachusetts Institute of Technology, Cambridge.
- Slovic, P., and A. Tversky. 1974. Who accepts Savage's axiom? *Behavioral Science*, Vol. 19, pp. 368–373.
- Stevens, S.S. 1946. On the theory of scales of measurement. *Science*, Vol. 103, pp. 677–680.
- Thrall, R.M. 1954. Applications of multidimensional utility theory. In *Decision Processes* (R.M. Thrall, C.H. Coombs, and R.L. Davis, eds.). John Wiley, New York.
- Tversky, A. 1972. Elimination by aspects: a theory of choice. *Psychological Review*, Vol. 79, pp. 281–299.
- Tversky, A., and D. Kahneman. 1974. Judgment under uncertainty: heuristics and biases. *Science*, Vol. 185, pp. 1124–1131.
- von Neumann, J., and O. Morgenstern. 1953. *Theory of Games and Economic Behavior*. 3rd ed. Princeton University Press, Princeton, New Jersey.

DISCUSSION

KEENEY: Suppose you have two attributes X and Y , and X is utility independent of Y and Y is utility independent of X . Furthermore, the utility function $u(x, y)$ is not additive, so it can be represented by the multiplicative utility function. Have you looked for the best additive approximation of this multiplicative utility function?

FISHBURN: No, I haven't looked at that case specifically. I have looked at a generalization of it, referred to as multivariate risk aversion or, alternatively, as

conservatism. I used the additive form for approximation, and the approximation was rather good in most cases. When you apply the additive form to that two-dimensional multivariate risk aversion situation, you know that the approximation cannot be exact. In addition, you can specify a lower bound on the uniform norm for that case.

MEYER: I was bothered by your use of the uniform norm. It may result in very nice pointwise approximations, but it approximates absolutely miserably in terms of risk aversion. There may be segments of the utility function with zero risk aversion over the pieces and others with infinite risk aversion at the points where there is a discontinuity. I think that what you really want as a norm is as good an approximation as you can achieve for the particular decision problem at hand. Perhaps what you want to use as your norm when you have a particular decision problem is the expected utility for the alternatives for that decision problem. Have you looked at that possibility at all?

FISHBURN: No, I haven't. This is a relevant concern in the context of a particular problem, and you are probably focusing on some fairly small subregion of the unit square or whatever space you are working in. In this smaller region, you can no doubt get a better approximation than you can for the entire region.

RAIFFA: For a unidimensional utility function, I find the work of Meyer and Pratt ("The Consistent Assessment and Fairing of Preference Functions," *IEEE Systems Science and Cybernetics*, SSC-4, 270–278, 1968) very illuminating about the question of approximating decreasing risk aversion utility functions. What is fascinating to me is the development in utility theory that goes something like this. Instead of obtaining an exact utility function, one tries first to get some qualitative ideas like decreasing risk aversion. Then, rather than specifying exact equivalents for 50–50 gambles, one determines bounds for these. Information like that can be translated into bounds on the utility function, and, very often, this information is enough to allow a choice among alternatives. It is not necessary to go through the whole procedure of deriving exact utility functions.

I don't know whether you can do that for two dimensions, but that is the direction I would like to see approximation theory take.

PESCHEL: How can you take into account the feasible set of alternatives? It may be that in the subset of nonfeasible points you get a good approximation and in the interesting subset — the feasible set — you get a bad approximation.

FISHBURN: Currently, I have no good answer to that.

TVERSKY: It seems to me that one question that is essential to the quality of an approximation is the problem of noise. The quality of an approximation may be very different when it is studied under considerable noise. There are some results that show that the quality of an approximation increases as you have more and more noise.

FISHBURN: I considered that very briefly in the preface of my paper on two-dimensional problems (Fishburn, 1975). In effect, for a first approximation, I presume that there is no noise. That is, one could estimate u precisely if one had

enough time. Bounding this noise complicates things considerably, and I have not done this, although I am aware of the problem.

EDWARDS: Some computational work has been done that addresses the same questions and theories from a different point of view. First of all, Fischer has investigated linear approximations of utility functions that are monotonic in each attribute. Generally, everything works beautifully. When very sharply nonlinear nonmonotonic functions are considered, things start looking not so good.

There is another issue that we should look into here, that of environmental independence, which is related to the questions raised by Dr. Peschel about the feasible set of alternatives. Certainly you are not going to want a meal that is overpriced and badly cooked. By the time you start reducing the list of alternatives to the ones that you are willing to retain seriously, you are going to introduce a large set of negative environmental correlations among the variables. Unfortunately, this will produce worse approximations. How much worse, I don't know. It's obviously going to be a function of, among other things, the number of dimensions. We are working on this now, and the results will be reported.

RAIFFA: As Dr. Fishburn pointed out, there are many kinds of independence assumptions that are convenient. If the ranges of the variables are wide, the assumptions become less palatable. By eliminating the alternatives that are obviously inferior, you can often limit the ranges so that you can tolerate certain kinds of independence assumptions that were intolerable before. This is an aspect of the art of assessment.

MEYER: In practice, the feasible set described on this hypercube that we have been talking about tends to lie in or near certain subspaces of lower dimension. Thus, a set of coordinates of smaller dimension that adequately characterize this subspace is desirable. The problem becomes one of assessment. How do you describe these other coordinates so that the person of whom you are asking questions can understand what they are? I think approximations such as those mentioned by Dr. Fishburn should be made in whatever subspace is relevant.

RAIFFA: We have talked about various dependence and independence assumptions. In practice, if things are dependent, then it is interesting to understand why they are dependent and to see if changes in variables or the factors Dr. Meyer mentions (Chapter 11) could create independence. We are all accustomed to such procedures in the probability domain. When we have variables that are probabilistically dependent, we use all kinds of tricks to make them independent or conditionally independent. To date, we haven't learned how to do much of this in the value and utility domain.

8 A Practical Methodology of Solving Multicriterion Problems with Subjective Criteria

O. I. Larichev

8.1 INTRODUCTION

One typical problem in surveys of decision making methods is the small scale of current practical applications of these methods (Clarke, 1974; Larichev, 1974). There are many reasons for this. The path between the beginning of the practical work and the possibility of application of a method is long and difficult. This path is interesting by itself, but most of its stages depend on the specific circumstances. In the following sections, possible factors hindering successful application of a number of decision-making methods are discussed, and directions for development of promising new methods are suggested.

8.2 THE PROBLEM

The decision-making problems under discussion here have the following characteristics: (a) the decisions are nonrepetitive; (b) the criteria for evaluating the alternatives are subjective in that they can be defined only by the decision maker(s); and (c) the alternatives can be evaluated in terms of these criteria only by experts.

This class includes strategic R&D planning, or selection of directions, topics, or projects (Clarke, 1974; Larichev, 1974). The manager of an agency responsible for strategic R&D planning has a policy that is expressed, above all, in a list of criteria for evaluating lines of research or specific R&D projects. Most criteria are essentially qualitative – for example, “skill of presumed participants” or “project status.” In estimating the alternative versions by these criteria, the decision maker should use the advice of experts. The situation in which the problem is solved is new each time, so no universal or standard solutions can be developed.

For many administrative and planning bodies, a large number of alternatives to evaluate and select among is increasingly common. This makes it hard for a manager

who wishes to retain his control over decision making even if he cannot evaluate the proposed alternatives himself.

8.3 THE MEASUREMENTS

For each criterion, a list of evaluations should be made, resulting in an evaluation scale. The criteria formulated by a decision maker represent his attitude toward the problem of selection. Because the decision maker has to use the advice of experts in evaluating the alternatives, these evaluative criteria and scales are the language of communication between the decision maker and his experts. Even with the best possible experts, the result is largely dependent on the way the data are secured from them.

In my view, quantitative scales of evaluation are quite inapplicable to subjective criteria. With subjective criteria a 10-point scale does not enable a decision maker to obtain any reliable data, since each expert will have his own idea on the grade of quality to be assigned to each point.

The only reasonable approach is to use discrete scales of evaluations with a small number of qualitative evaluations in the form of verbal formulations of quality grades. These formulations also represent the decision maker's policy and his desire to distinguish certain qualitative differences in terms of a specific criterion. The formulations should be sufficiently detailed that experts can understand which grades are important to the decision maker. Evaluations on such scales, including the definitions of the best and the worst, represent the opinion of the decision maker; with another decision maker, these estimates might be quite different.

Table 8.1, adapted from Filippov *et al.* (1974), shows a possible scale for a very involved criterion, "promise of the line of research." A detailed formulation is needed to make the content of each estimate understandable to a set of experts.

Such scales greatly increase the confidence of decision makers in the data provided by the experts. Even though he agrees with quantitative scales, a rationally minded decision maker still does not completely rely on them because he understands the complexity, novelty, and ambiguity of measuring qualitative, subjective notions in numerical terms. Verbal scales enable the decision maker to request from the experts exactly what he needs.

8.4 SUBJECTIVE SELECTION RULES

The problem of evaluating the multicriterion alternatives will be solved when relations of utility are determined for all or some combinations of estimates in terms of the criteria. With subjective criteria these relations can be obtained only on the basis of knowledge of the decision maker's goals and preferences. Indeed, the degree to which evaluations in terms of partial criteria are combined in the

TABLE 8.1 Estimating the Promise of Basic Scientific Research in a Field (Probability of Breakthroughs)^a

Criterion	Definition
B_1	World scientific consensus is that breakthroughs are highly probable and can lead to new theories and experimental methods.
B_2	World scientific consensus is that there are grounds (enough "mature," well-posed theoretical and experimental problems) to allow the formulation of more general theories, qualitatively different approaches to the description of the object of studies, new principles of experimental studies, and new scientific schools.
B_3	World scientific consensus is that steady growth, accumulation, and generalization of theoretical results and improvement of principles and methods of experimentation will continue over the next 5 to 10 years.
B_4	World scientific consensus is that there is little probability of qualitative changes; there is little innovation in approaches and research methods, and none is likely.
B_5	World scientific consensus is that further basic research in this direction will lead nowhere; the probability of reorienting the theories and research methods in this direction is very low.

^a Adapted from Filippov *et al.* (1974).

overall evaluation cannot be determined through impartial computation. It is in comparison in terms of combinations of evaluations that the decision maker's goals and his attitude toward the problem of selection are represented.

The relations of different combinations of evaluations leading to the desired form of presenting the final decision will be referred to as the subjective model of decision making.

How subjective decision-making models for many criteria should be developed is a difficult question. There is a classical way (Morris, 1968) to determine preferences by comparing the utility of different lotteries; this approach, however, has been the object of valid criticism (Hall, 1965). It has been shown that in real situations people do not act in compliance with the preferences revealed by this technique (Dolbear and Lave, 1967). Apparently, even if people take the experiments seriously, they are aware of the wide difference between actual and model situations. Also, people tend to make mistakes in determining subjective probabilities (Tversky and Kahneman, 1973). In my view, the classical way of revealing preferences is especially ill-suited to unique, nonrepetitive decision-making problems.

The above technique is not the only one in which decision maker's preferences are used; there are also man-machine methods of decision making (Larichev, 1971), but these methods disregard descriptive data on the possibility of obtaining reliable information for people. In most cases, man is implicitly presumed to be omniscient. Clearly, any preference-revealing procedures should rely on psychological

and psychometric data on possibilities of elicitation of reliable information from people in different situations.

The hypothesis that people respond probabilistically in solving comparison or selection problems seems to be well tested (Luce *et al.*, 1963): there is a high probability that consistent answers will be obtained for a certain kind of problem, but these answers are not necessarily correct.

Many authors (Marschak, 1968; Mirkin, 1974) agree that the basic reason for the observed violations of the transitivity of preferences is the large number of attributes in the objects to be compared, which cannot be tackled by a single person at one time. This hypothesis also seems to be well tested.

These two hypotheses lead to the following suggestions for procedures for finding the preferences of decision makers and for procedures for design of subjective decision-making models. Above all, these procedures should include stability and consistency tests of decision maker's preferences. Also, the procedures should use those questions for which the probability of obtaining reliable information is the highest. Hypotheses concerning the possibility of obtaining the desired information from a decision maker should be formulated and tested.

Let us give one example. Scales of different criteria are taken in pairs [with N criteria, the number of such pairs is $\frac{1}{2}N(N-1)$]. Let the evaluations according to all the criteria be ordered, with performance decreasing from the beginning to the end of the scale. The hypothesis is as follows: with $N \leq 6$ or 7 , the decision maker can, with small violations of transitivity, compare the performance deterioration in the scales of two criteria with the best estimates in terms of the other criteria.

To test the hypothesis, suppose we have the following scales of the criteria A and C :

Criterion A: R&D Project Status

A_1 The considerable amount of work necessary for the project has already been completed. No essential difficulties are expected in the remaining work.

A_2 A number of essential difficulties have to be overcome to complete the R&D project, but ideas on how to solve them exist and directions of research have been specified.

A_3 A number of novel little-known problems have to be solved, and no ideas or proposals on their solution are available.

Criterion C: Necessary Resources

C_1 No additional resources are required for the project; only some organizational arrangements are needed.

C_2 More personnel and material resources are needed within the framework of existing laboratories.

C_3 New laboratories should be set up for the project.

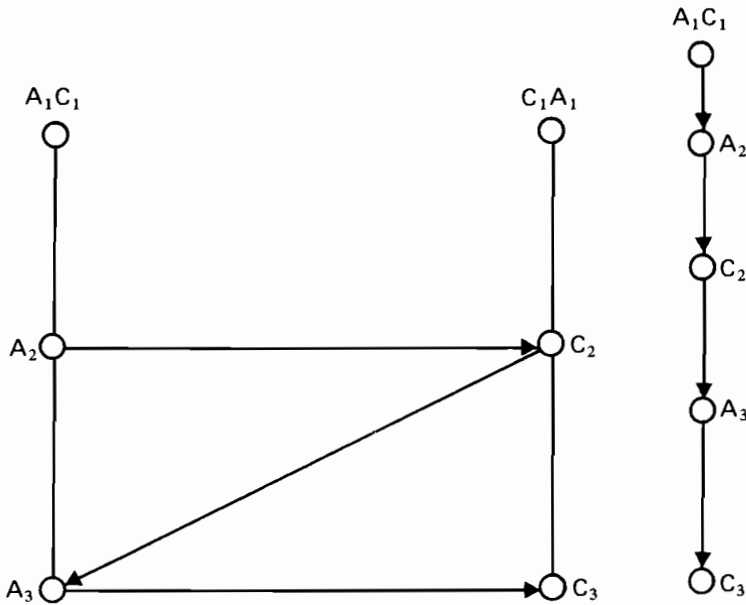

FIGURE 8.1 Uniform scale of criteria A and C .

The decision maker is told that initially the object has the highest values in terms of all the N criteria. Let us take up two cases: (a) the performance in terms of the criterion A has deteriorated (the value A_2 should be used instead of A_1); and (b) the performance in terms of the criterion C has deteriorated (the value C_2 should be used instead of C_1). The question is which of the cases is associated with a greater deterioration in performance. The answers were used to plot the graph of Figure 8.1 where the arrow denotes better performance; by this means, two scales may be replaced by one scale of estimates for the two criteria A and C . In this way, all pairs of criteria are considered. The information needed to obtain a single scale for the N criteria is duplicated, with the amount of redundant information increasing with the number of criteria. That redundant information can be used to test the above hypothesis.

The data obtained in testing the above hypothesis confirm its validity. Thus, no violation of transitivity was observed in questioning four decision makers with four criteria and from three to five qualitative estimates on the scales. In questioning with six criteria, two answers out of fifty-six were contradictory.

What is important is that all answers were concerned with real situations. The decision maker used his language in verbal evaluations for description of the situation, and he consistently pursued his goals in making the comparisons. The

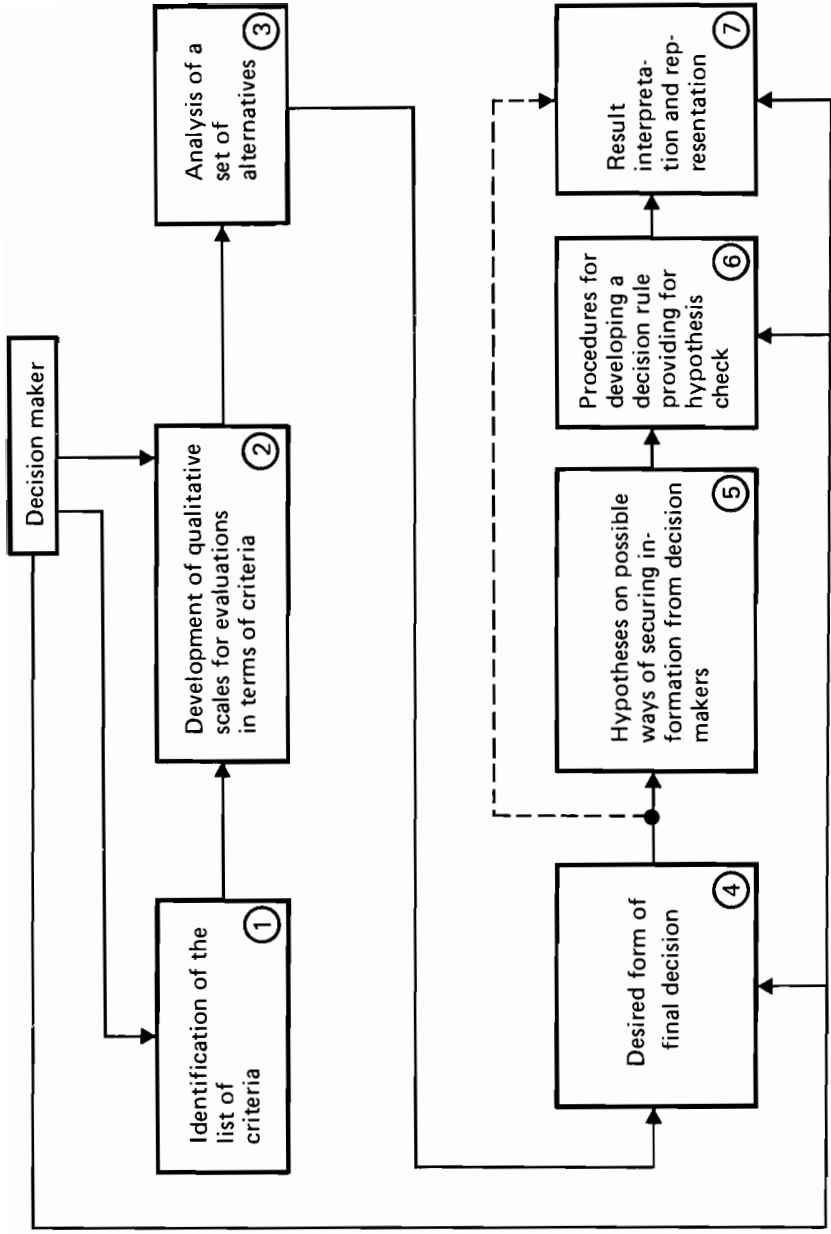

FIGURE 8.2 Stages of decision making with subjective criteria.

results of testing this hypothesis indicate that comparisons of performance deteriorations in pairs of scales can be used in procedures to reveal the preferences of decision makers (see, for example, Larichev *et al.*, 1974b).

8.5 STAGES OF DECISION MAKING WITH SUBJECTIVE CRITERIA

The need for separate stages for identifying the list of criteria and development of qualitative verbal scales of evaluations was discussed above (Figure 8.2). Special attention should be given to stage 3. If the set of multicriterion alternatives is specified (e.g., expert evaluations are obtained for the alternatives under study), then it would be useful to analyze that set by the methods of clustering (Ayvazian *et al.*, 1974) and decreasing the dimensionality of data (Teryokhina, 1973). In a number of cases this analysis may affect the initial requirements of decision makers as to the form in which the final decision should be represented, and in certain cases analysis may result in immediate solution of the overall problem. If a decision maker wants the set of alternatives to be divided into a small number of classes and analysis shows that they decompose into three groups, then it would be logical to assume that a final decision would require division of the alternatives into three classes. If analysis also reveals that the resulting three groups are in domination relation (each object in the first group is better than each one in the second group in terms of all criteria, and each object in the second group is better than each one in the third group in terms of all criteria), then the desired decision has been obtained.

The desired form of the final decision significantly affects the problem of decision making with subjective criteria. The most common forms are listed below:

- The alternatives are divided into two groups (with the better one identified).
- The alternatives are divided into a small number of groups.
- The alternatives are divided into a number of groups approaching, if possible, the number of combinations of criterion evaluations.

At stages 5 and 6 the data of preceding stages are used to develop the overall procedure for design of the decision rule, with the decision maker's preferences taken into consideration. Hypotheses are formulated on possible ways to obtain the data from decision makers; also formulated are ways to check these hypotheses. The chief difficulty is in constructing procedures that can lead to a representation of the final decision that incorporates those hypotheses that are the simplest and easiest to check.

8.6 AN EXAMPLE

The proposed approach was used in developing a method for planning applied research and development (Larichev *et al.*, 1974a,b), a method for selecting

promising directions of basic research (Filippov *et al.*, 1974), and a method for estimating the quality of scientific manuscripts (Larichev and Glotov, 1974).

One of these methods was applied to a problem (Larichev *et al.*, 1974a) that can be regarded as portfolio optimization where the criterion of maximal economic efficiency can be applied. In reality, however, a planning body recognizes a number of qualitative criteria as well as cost and economic efficiency. Following the identification of a list of criteria and development of scales, all R&D projects were divided into two groups:

Those for which the effect of qualitative criteria dictates incorporation in the plan in some version – especially important projects (EIP).

Those whose inclusion in or exclusion from the plan depends on the indices of costs and cost effectiveness – common projects (CP).

The alternatives should thus be divided into EIPs and CPs. Note that in the practical cases under consideration analysis of data by dimensionality-reducing methods has revealed a large number of groups. To develop a subjective decision rule for dividing the objects into two classes, the following hypothesis was put forward:

Hypothesis 1 With $N \leq 6$ and two classes of final decisions (CPs and EIPs) the decision maker can in a stable way (with good repeatability with repeated questioning) and consistently (with rare violations of transitivity) assign classes of final decisions to all combinations of estimates of two criteria under the assumption of best estimates in terms of the other $N - 2$ criteria.

As an example consider combining criteria D and F defined as follows:

Criterion D: Social effect of implementing an R&D project

D_1 The project will have a direct and very large effect on improving the living standard of the population.

D_2 The project will make a direct contribution to improving the living standard of the population.

D_3 The project will make no direct impact on the living standard of the population.

Criterion F: Expected results compared with world standards

F_1 Expected results will surpass world standards.

F_2 Expected results will be on a par with world standards.

F_3 Expected results will be below world standards.

The information required from the decision maker is given in Figure 8.3. To check Hypothesis 1, one can use data redundancy resulting from treating all pairs of criteria and repeated questioning of decision makers over a period long enough to

	F ₁	F ₂	F ₃
D ₁	EIP	EIP	EIP
D ₂	EIP	CP	CP
D ₃	CP	CP	CP

FIGURE 8.3 Information required from decision maker. See text for definitions.

allow them to forget their earlier estimates when there are many of these (1 or 2 weeks).

In developing a decision rule, the following generalization may be used: with deterioration in estimations the performance of R&D projects does not increase. In other words, if some combination of estimations is associated with CPs, then all combinations dominated by that combination also belong to that class. When the estimations are binary and combinations of worse values of any three criteria are necessarily associated with CPs, the data from decision makers who fill in tables similar to Figure 8.3 for all pairs of criteria are sufficient for developing a decision rule. One can arrive at this particular case by combining the estimates of criteria that have the same effect on the quality of projects.

In a general case the information obtained through Hypothesis 1 is insufficient for obtaining a decision rule. There may be combinations of estimates with indefinite classes of quality. In this case, the following step can be proposed: boundaries that divide projects into EIPs in the space of N criteria should be checked in compliance with the following hypothesis.

Hypothesis 2 With $N \leq 6$ and two or three classes of final decisions (in our case two classes, EIPs and CPs), the decision maker can consistently compare projects differing in evaluations in terms of two criteria.

R&D projects that are on the boundary between EIPs and CPs are compared with other, nondominated ones whose evaluation differs in terms of two criteria. Let the character \rightarrow denote better quality. Evidently, for the projects P_1 and P_2 , if $P_1 \rightarrow P_2$ and $P_2 \in \text{EIP}$, then $P_1 \in \text{EIP}$. If $P_1 \rightarrow P_2$ and $P_1 \in \text{CP}$, then $P_2 \in \text{CP}$. Hypothesis 2 is checked through numerous comparisons to obtain redundant information.

In actual design of the decision rule by the above method (with $N = 4, 5$, or 6) the number of combinations associated with EIPs was not very large. Therefore, only the data obtained through Hypothesis 1 could be used. That information was consistent, which confirms Hypothesis 1.

8.7 CONCLUSIONS

One characteristic feature of many weakly structured problems (Opther, 1965) tackled by systems analysis is the subjective nature of their models. Neglect of this fact and desire to obtain "pseudo-objective" models is one of the chief causes of the failure of practical application of systems analysis methods and theories to a wide range of problems (Schlesinger, 1963).

There are many problems in which qualitative, little-known, and uncertain aspects tend to dominate. Solution of these problems may be made easier if a method suitable to a particular decision maker or a group of decision makers is devised and if a special-purpose language is developed to enable the decision maker to express his policy and preferences as a subjective decision-making model.

REFERENCES

- Ayvazian, S.A., Z.I. Bezhaeva, and O.V. Staroverov. 1974. *Classification of Multidimensional Observations*. (In Russian.) Statistika, Moscow.
- Clarke, T.E. 1974. Decision making in technology based organizations: a literature survey of present practice. *IEEE Transactions on Engineering Management*, Vol. EM-21, pp. 9-23.
- Dolbear, F.T., and L.B. Lave. 1967. Inconsistent behavior in lottery choice experiments. *Behavioral Science*, Vol. 12, pp. 14-23.
- Filippov, V.A., O.I. Larichev, V.S. Boychenko, and M.K. Albertyan. 1974. Methodological problems of R and D planning. In *R and D Perspective Planning* (S.V. Emelyanov, ed.). (In Russian.) Nauka, Moscow.
- Hall, A.D. 1965. *A Methodology for Systems Engineering*. Van Nostrand, New York.
- Larichev, O.I. 1971. Man-machine procedures of decision-making (review). (In Russian.) *Avtomatika i Telemekhanika*, No. 12, pp. 130-142.
- Larichev, O.I. 1974. Organizational systems and methods of strategic planning of R and D (a survey). (In Russian.) *Avtomatika i Telemekhanika*, No. 5, pp. 133-142.
- Larichev, O.I., A.I. Bogdanov, V.V. Pavelyev, A.Iu. Teryokhina, K.G. Genev, and I.D. Slavkov. 1974a. Method of R and D plan formation. In *R and D Perspective Planning* (S.V. Emelyanov, ed.). (In Russian.) Nauka, Moscow.
- Larichev, O.I., and V.A. Glotov. 1974. Organizational system and scientific article quality estimation method. In *R and D Perspective Planning* (S.V. Emelyanov, ed.). (In Russian.) Nauka, Moscow.
- Larichev, O.I., U.A. Zuev, and L.S. Gnedenko. 1974b. Method of R and D projects classification. In *R and D Perspective Planning* (S.V. Emelyanov, ed.). (In Russian.) Nauka, Moscow.
- Luce, R.D., R.R. Bush, and E. Galanter (eds.). 1963. *Handbook of Mathematical Psychology*. John Wiley, New York.
- Marschak, J. 1968. Decision making: economic aspects. In *International Encyclopedia of the Social Sciences*. Vol. 4. Crowell, Collier, Macmillan, New York.
- Mirkin, B.G. 1974. *Problems of Group Choice*. (In Russian.) Nauka, Moscow.
- Morris, W.T. 1968. *Management Science: A Bayesian Introduction*. Prentice-Hall, Englewood Cliffs, New Jersey.
- Opther, S.L. 1965. *System Analysis for Business and Industrial Problem Solving*. Prentice-Hall, Englewood Cliffs, New Jersey.
- Schlesinger, I.R. 1963. Quantitative analysis and national security. *World Politics*, Vol. 15, No.2.

- Teryokhina, A. Iu. 1973. Methods of multidimensional data scaling and visualization (a review). (In Russian.) *Avtomatika i Telemekhanika*, No. 7, pp. 80–94.
- Tversky, A., and D. Kahneman. 1973. Judgment under uncertainty: heuristics and biases. *Oregon Research Institute Research Bulletin*, Vol. 13, No. 1.

DISCUSSION

KEENEY: What experiences have you had in trying to generate subjective scales for real problems? Could you give me an example of one case where you have done that?

LARICHEV: I can refer to Figure 8.1. The two criteria, the amount of work necessary to complete a project and the resources necessary for this completion, were part of an analysis with real decision makers.

EDWARDS: I may have misunderstood, but I think you said that decision makers prefer to express their opinions in a rather small number of categories and, indeed, that they can do so only in this way, and that it is therefore undesirable to present them with a larger response set. Did I misunderstand that?

LARICHEV: The number of evaluation points on each scale depends on the particular case. We are trying – with the help of a decision maker – to find what the desirable number of evaluation points is in real situations. Sometimes you cannot place more than 5 points on a qualitative scale. In our practice we have usually had no more than 6. Of course, it is much easier to expand this if we have a quantitative scale.

RAIFFA: Suppose you have the situation depicted below, in which you write down your alternatives x and y and have criteria A, B, C , and D where levels of each of these are characterized by a verbal description.

Alternatives	Criteria			
	A	B	C	D
x	A_2	B_1	C_4	D_6
y	A_1	B_3	C_2	D_4
w	A_2	B_1	C_2	D_4

You could ask decision makers directly how they would feel about x and y . As another approach, do you ever create a hypothetical choice w , where w might be (A_2, B_1, C_2, D_4) ? Notice that w is designed so that it makes it easy to make a choice between y and w because they are equivalent on criteria C and D . Similarly, x and w are equivalent on criteria A and B . It may be clear to the decision makers that y is better than w , and it may be clear that w is better than x . Therefore, creating a hypothetical situation might help the decision makers conclude that x is better than y .

LARICHEV: Of course in this case you can utilize this approach, but, as you said, it is easy now because you have the difference in only two criteria. In our

problems, when there were many alternatives, it was impossible for decision makers to compare all the alternatives directly. It was necessary for us to utilize ways that directly compare only some of the alternatives that differ in a few criteria. Each problem requires a new decision on the best manner to do this. I think this is a very important question.

RAIFFA: When you compare pairs on criteria A and B , are you holding C fixed?

LARICHEV: I am holding C fixed at the best evaluation, which I describe verbally to the decision maker.

9 On the Elicitation of Preferences: Descriptive and Prescriptive Considerations

A. Tversky

Decision analysis is a formal framework for analyzing complex decisions involving uncertainty and multiple objectives (see Keeney and Raiffa, 1976). It consists of a coherent set of logical and statistical procedures, designed to assist the decision maker in his search for optimal decisions. The data base for decision analysis contains hard facts such as resources, costs, and deadlines, as well as subjective judgments that express the beliefs and the values of the decision maker. Although it is desirable to substitute objective facts for subjective judgments whenever possible, most decision analyses contain a significant judgmental component.

In the absence of objective procedures for measuring probabilities and values, the subjective judgments of the decision maker are treated as measurements of uncertainty and value. Thus, the human judge serves as a measuring device for the assessment of uncertainty and value, much as a ruler or a pan-balance is used to measure distance and weight. Unlike physical measurements, however, which are usually unbiased and fairly accurate, expressions of preferences and beliefs are usually fallible and often biased.

Decision analysts are painfully aware of the presence of inconsistencies and biases in judgments of values and beliefs. Indeed, the responsible decision analyst does not "accept" judgmental data without probing further and conducting tests of consistency. The analyst then encourages the decision maker to revise his judgments whenever they are inconsistent or unreasonable.

Decision theory demands coherence, yet it provides no clues to how it should be achieved. Given the fallibility of human judgments, what are the major sources of judgmental error? What methods, or tests, should the analyst use to detect biases and inconsistencies? How should the decision maker resolve his inconsistent preferences? Formal decision theory does not address these questions because it does not acknowledge the fallible nature of judgmental data. Consequently, the decision analyst must look elsewhere to find answers to these questions.

The psychological analysis of the judgmental processes underlying the elicitation of preferences and beliefs yields several results that are relevant to the conduct of decision analysis. First, it isolates several classes of problem in which human intuition is at variance with the maxims of rational choice. Second, it sheds light on the nature of judgmental inconsistencies and indicates the avenues of inquiry that lead to their resolution. Third, it suggests procedures for structuring the decision problem and the elicitation task in order to eliminate, or at least reduce, judgmental biases.

Over the past 5 years, Daniel Kahneman and I have studied the cognitive processes underlying the formation of preference and belief. Our research has shown that subjective judgments generally do not obey the basic normative principles of decision theory. Instead, human judgments appear to follow certain principles that sometimes lead to reasonable answers and sometimes to severe and systematic errors. Moreover, our research shows (Tversky and Kahneman, 1974; Kahneman and Tversky 1976) that the axioms of rational choice are often violated consistently by sophisticated as well as naive respondents, and that the violations are often large and highly persistent. In fact, some of the observed biases, such as the gambler's fallacy and the regression fallacy, are reminiscent of perceptual illusions. In both cases, one's original erroneous response does not lose its appeal even after one has learned the correct answer. The present paper discusses some recent work, by Daniel Kahneman and me, on the psychology of preference. Specifically, the paper describes two widespread phenomena, called the certainty effect and the reference effect, that lead to systematic violations of expected utility theory. These effects are illustrated, and their implications for decision analysis are discussed.

9.1 THE CERTAINTY EFFECT

Let (x, p, y) denote the option where outcome x is obtained with probability p , and outcome y with probability $1 - p$. The option of receiving x with certainty is denoted by (x) . The outcomes x, y , and so on could denote any monetary or nonmonetary consequences. The present discussion is primarily concerned with two numerical attributes: human life and money. For simplicity, we shall restrict the discussion to so-called objective probabilities, although our conclusions are not limited to this case. To illustrate the certainty effect, consider the following problem.

The Ministry of Health is faced with a choice among various programs for the development of sophisticated medical equipment, such as kidney machines. Suppose the costs associated with the various programs are roughly the same and the programs are judged by the number of lives they are expected to save. The decision maker faces a choice between one program that has a 50-50 chance of saving 100 lives or none and another program that could save 45 lives with complete certainty. The overwhelming majority of respondents who were presented with this choice selected the second alternative. That is, they chose (45) over $(100, 1/2, 0)$. The

same respondents were then presented with the choice between a program that has 1 chance in 10 to save 45 lives or no lives, and a program that has 1 chance in 20 to save 100 lives or no lives. In this case, the great majority of respondents selected the latter option, preferring $(100, 1/20, 0)$ to $(45, 1/10, 0)$.

These preferences are clearly incompatible with utility theory. To demonstrate, note that the first preference implies that $2u(45) > u(100)$ with $u(0)$ set equal to zero, whereas the second preference implies the reverse inequality. Specifically, these preferences violate the substitution axiom of utility theory, according to which the preference order is invariant over probability mixtures. That is, if an option a is chosen over another option b , then $(a, p, 0)$ must be chosen over $(b, p, 0)$, for any p . In the present example, the last two options are expressible as probability mixtures of the first two options and zero with a probability of 0.1. The above preferences indicate, therefore, that the substitution of a sure thing in a gamble could reverse the preference ordering. Put differently, it suggests that the estimated utility of saving 45 lives is higher when inferred from a choice in which this outcome is certain than when it is inferred from a choice in which this outcome is not certain.

The above alternatives were evaluated in terms of number of lives saved. We also presented the same group of respondents with choices between alternatives concerning the loss of human lives. These problems were formulated in terms of the risks associated with various hazards, such as accidents. The decision makers were to choose between a 50-50 chance to lose 100 lives or none and a sure loss of 45 lives. Almost all respondents chose the first option. Next, they were to choose between a 1-in-20 chance to lose 100 lives, and a 1-in-10 chance to lose 45 lives. Here, the great majority of respondents chose the second option. Thus, our respondents chose $(-100, 1/2, 0)$ over (-45) , yet they chose $(-45, 1/10, 0)$ over $(-100, 1/20, 0)$. These preferences, again, violate utility theory because the former implies that $u(-100) > 2u(-45)$, whereas the latter preference implies the reverse inequality. Thus, they suggest that the disutility of a loss of 45 lives is greater when it is inferred from a choice in which this outcome is certain than when it is inferred from a choice in which it is uncertain.

Several comments about the above examples are in order. First, the respondents were all graduate students and faculty members in the School of Social Sciences at the Hebrew University in Jerusalem. They were given considerable time to think about and reflect on their choices. Furthermore, the respondents whose preferences were inconsistent with utility theory were given the opportunity to revise their preferences. While most of the respondents expressed mild embarrassment for violating utility theory, very few were inclined to modify their choices. Second, the preferences for negative gambles were the mirror image of the preferences for the positive gambles. This is a direct consequence of the certainty effect. Third, precisely the same pattern of preferences was obtained when monetary gains and losses were substituted for human lives. The pattern of preferences for the corresponding monetary gambles is given below.

For positive-outcome gambles we obtained

$$(\$45) > (\$100, 1/2, 0) \text{ and } (\$45, 1/10, 0) < (\$100, 1/20, 0),$$

whereas for negative-outcome gambles we obtained

$$(-\$45) < (-\$100, 1/2, 0) \text{ and } (-\$45, 1/10, 0) > (-\$100, 1/20, 0).$$

In summary, we have argued that human preferences are subject to a major bias, the certainty effect, according to which the utility (or the disutility) of an outcome looms larger when it is certain than when it is uncertain. The certainty effect captures an essential component of people's attitudes toward risk that is reflected in the differential treatment of certain and uncertain outcomes. It leads to risk-aversion for positive outcomes and risk-seeking for negative outcomes. Such risk averages, however, are incompatible with any concave or convex utility function. Expected utility theory deals with the problem of risk through the shape of the utility function for the respective attribute – e.g., money. In this respect, utility theory does not permit attitudes toward risk *per se*, only attitudes toward money. Note, incidentally, that the so-called paradoxes of Allais (1953) are all manifestations of the certainty effect.

9.2 THE REFERENCE EFFECT

People generally perceive and evaluate stimuli relative to some reference point, or adaptation level, provided by the past and present context of experience. For example, an object at a given temperature may be experienced as hot or cold to the touch, depending on the temperature of objects to which one has become adapted. Similarly, a given letter of recommendation may be interpreted as more or less favorable depending on one's expectations. In the same fashion, the consequences of decisions are commonly perceived and evaluated as positive or negative changes from some neutral reference point. Financial investments, for example, are usually evaluated in terms of their potential gains or losses, and public policies are often discussed in terms of the (positive or negative) changes that they are likely to bring about.

The reference point defines the neutral point in the outcome space. Outcomes that lie above the reference point (in the preference order) are perceived as positive, and outcomes that lie below the reference point are perceived as negative. Hence, by changing the reference point, one changes the perceived sign of the outcomes. A new product, for example, could be regarded as a success when compared to competing products, or as a failure when compared to the original plan. A tourist who had lost \$50 in one evening at the roulette wheel could regard this outcome as a gain of \$50 if he had budgeted \$100 for spending in the casino that evening. As we shall demonstrate below, a change in the reference point affects the evaluation of outcomes and the preference between options. Changes in preferences due to a shift in the reference point are called reference effects.

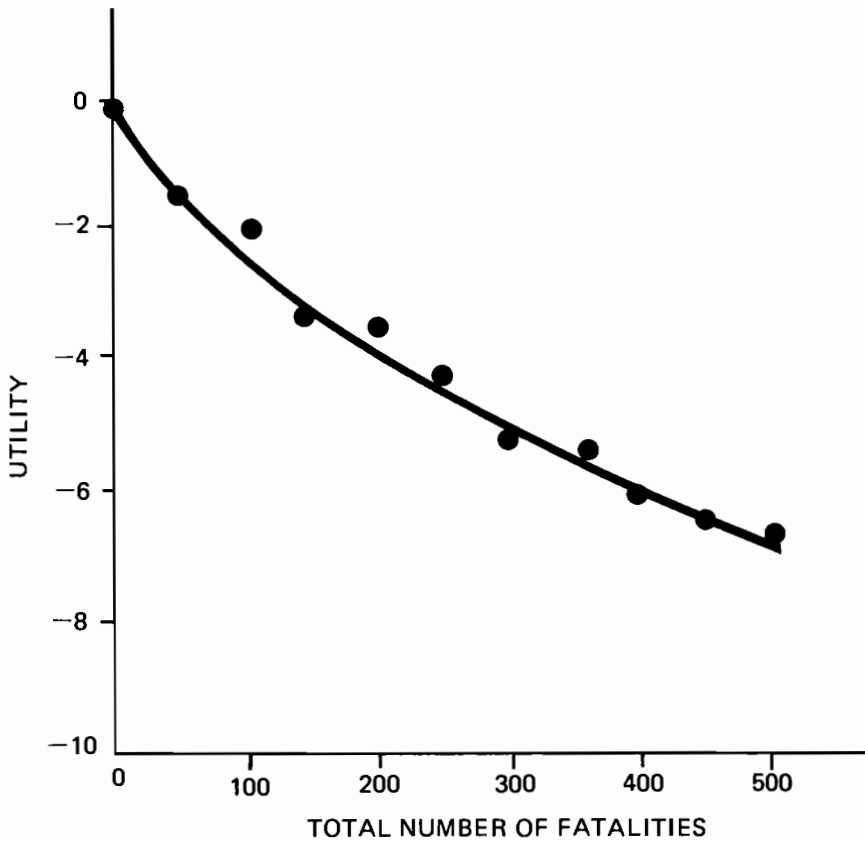

FIGURE 9.1 Utility function for the total number of fatalities in traffic accidents per year.

To illustrate this effect, consider the problem of assessing society's utility function for loss of life in traffic accidents. A typical utility function, as assessed by a scientific advisor to the Israeli Public Committee for the Prevention of Traffic Accidents, is displayed in Figure 9.1. This function was constructed on the basis of the expert's ordering of utility intervals. Specifically, the expert was presented with problems of the following type.

Consider a reduction of the yearly death toll due to traffic accidents from 500 to 400, and compare it with a reduction from 200 to 100. Which of the two reductions is more significant in the sense that it justifies larger public expenditure? After the expert stated that the former reduction is more valuable than the latter, the reductions were modified until the expert judged them to be equally valuable. On

the basis of such judgments, it was possible to construct the expert's utility function (Figure 9.1) for the total number of lives lost in traffic accidents. The function is clearly convex, indicating that the value of the life of any single person decreases with the total death toll. To validate this function we asked the expert to choose between different uniform distributions of fatalities. For example, the expert was asked to compare a uniform distribution of fatalities over the range (100, 500), with a uniform distribution over the range (200, 400). In this case, for example, the expert preferred the former distribution since "the difference between 100 and 200 fatalities appears larger than the difference between 400 and 500 fatalities." In general, the expert's choices between uniform distributions of fatalities agree with his utility function. Essentially the same utility function was obtained using two different procedures: a direct ordering of intervals and preference between gambles.

These results are not restricted to a single expert. Other individuals who were questioned using the same procedures also yielded convex utility functions over the same domain. A similar function for loss of life due to accidents in transporting hazardous substances is reported by Kalelkar *et al.* (1974).

Although traffic safety is measured by the total number of accidents or fatalities, much of the discussion of new measures, such as a change in the speed limit, is in terms of the potential increase or decrease in the current death toll. Therefore, we have also assessed the utility function of our expert for increases and decreases in the current level of fatalities due to traffic accidents. This function was constructed using the procedures described above, except that the attribute under study was defined as changes in the number of fatalities rather than as the total number of fatalities. Again, the data are orderly and consistent, and the ordering of intervals generally coincides with the choices between gambles. However, the resulting utility function, presented in Figure 9.2, is clearly inconsistent with the utility function of the same expert presented in Figure 9.1.

Several features of Figure 9.2 are worth noting. First, the significance, or value, of intervals generally coincides with the choices between gambles. However, the are saved or lost. For example, our expert felt that society would be willing to invest more to increase the number of lives saved from 100 to 200 than from 400 to 500. Similarly, he felt that society would be willing to pay more to prevent an increase of the number of lives lost from 100 to 200, than to prevent an increase from 400 to 500. Such judgments gave rise to a utility function shaped like a backward S, which is centered on the current death toll.

A second feature of Figure 9.2 is that the utility for life lost is steeper than the utility for life saved. For example, according to our expert, society would be willing to pay more to prevent a given increase in the death toll than to reduce the death toll by the same amount. In particular, the present state was preferred by the expert to any gamble with an even chance to increase or decrease the death toll by x lives.

A comparison of Figures 9.1 and 9.2 reveals the role of the reference point in the assessment of utility functions. Apparently, the manner in which the problem is

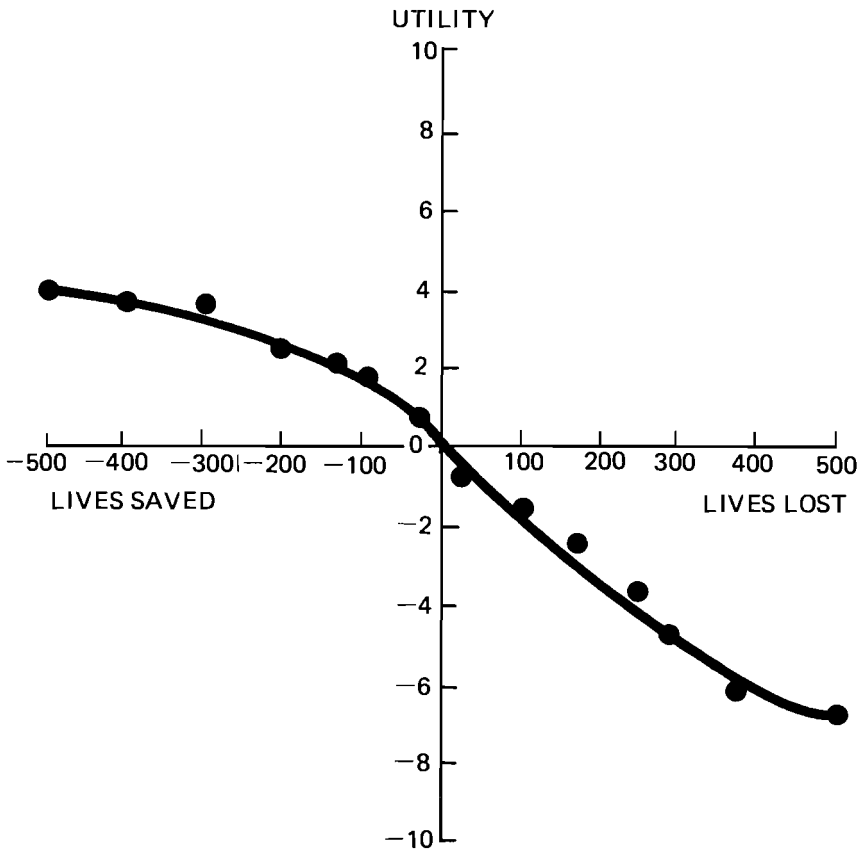

FIGURE 9.2 Utility function changes in the number of fatalities in traffic accidents per year.

formulated determines one's reference point, which, in turn, determines the shape of one's utility function. When the problem is stated in terms of the total number of fatalities, zero fatalities is the natural reference point, and most people prefer an even chance of losing 500 lives or nothing to an even chance of losing 100 or 400 lives. When the problem is stated in terms of changes in the number of fatalities, the current level serves as the reference point. Suppose the current (yearly) death toll is 500 lives. Then the problem becomes a choice between an even chance to save 500 lives or nothing and an even chance to save 100 or 400 lives. Here, almost all respondents prefer the latter option, contrary to their earlier choice.

The reference effect is not restricted to the assessment of the value of life. Very similar findings are obtained for other attributes, notably money. When the utility for money is assessed in terms of assets or wealth, one typically obtains concave

functions. When the utility for money is assessed in terms of gains and losses, however, one often obtains S-shaped functions centered on the status quo. Several examples of such utility functions elicited from corporate executives are reported by Swalm (1966). Despite large differences in the ranges (the investigator adjusted the range to the planning horizon of each executive) of the utility functions, their shapes were very similar.

The reference effect is not limited to the assessment of unidimensional utilities. It could also play a role in the assessment of multiattribute utility functions. To illustrate, we presented a group of students with the following problem. Suppose you can work an additional hour every day for an extra pay of 12 Israeli pounds. Would you accept this offer? A second group of students was presented with the converse problem. Suppose you can reduce your work load by 1 hour per day, and reduce your pay by I£12. Would you accept the offer? Almost all the participants had been employed on either a part-time or a full-time basis.

In the absence of any effect due to the reference point, the overall proportion (in both groups) of respondents willing to accept the new offer should be one-half. On the other hand, if the utility associated with negative changes is steeper than the utility associated with positive changes, then the overall majority of respondents (in both groups) should reject the new offer. This is precisely what happened. In each one of the questions, the majority of subjects preferred their present state to the new offer. This result indicates that assessment of multiattribute utilities depends on one's reference point and that the asymmetry between positive and negative changes induces a conservative bias favoring the status quo.

These findings illustrate a general phenomenon, called the reference effect, summarized by the following propositions:

First, attributes are often perceived and evaluated relative to some reference point. The reference point typically corresponds to the status quo of the adaptation level, although it may also reflect one's expectations or level of aspiration. As demonstrated in the above examples, different formulations of the same decision problem could result in different reference points.

Second, the marginal utility of an attribute usually decreases with the (absolute) difference from the reference point. According to this principle, the shape of the utility function depends critically on the location of the reference point. If the reference point coincides with the lowest value of the attribute, as in the assessment of the utility for wealth, the resulting utility function will be concave. If the reference point coincides with the highest value on the attribute, as in the assessment of the utility for losses of lives or money, the resulting utility function will be convex, as in Figure 9.1. Finally, if the reference point corresponds to some intermediate value of the attribute, as in the assessment of the utility for gains and losses, the resulting utility function will be concave above the reference point and convex below it.

Third, the utility for negative changes is steeper than the utility for positive

changes. Thus, $u'(x) < u'(-x)$, provided u is increasing, and $u(0) = 0$, where u' is the first derivative of u . The utility of gaining x units is thus generally smaller than the disutility of losing x units. Whether a given outcome is viewed as a gain or a loss is determined by the reference point.

The proposed principles of preference described above are closely related to some of the basic principles of perception and judgment. First, our perceptual apparatus is attuned to the evaluation of changes or differences rather than to the evaluation of absolute magnitudes. People are much better in detecting changes in attributes such as illumination or noise level than in evaluating the absolute level of these attributes. Second, for most sensory and perceptual continua, the sensitivity to changes decreases as one moves away from the adaptation level. Thus, the slope of the subjective scale decreases with the distance from the reference point. A given cost that appears exorbitant by itself often becomes insignificant when placed in the context of a much larger expense. Note that this phenomenon implies that people's utility function for losses is risk seeking and not risk averse. Third, a greater sensitivity to negative than to positive changes is perhaps one of the basic properties of the human organism; a high sensitivity to loss, pain, and noxious stimuli has a definite adaptive value.

9.3 SUMMARY AND COMMENT

The preceding sections described two phenomena, the certainty effect and the reference effect, that reflect people's attitudes toward risks and toward changes. These effects are common, stable, and persistent. They apply to many attributes, and they can be found in the choices of both naive and sophisticated individuals. Nevertheless, they are incompatible with the standard interpretation of expected utility theory. These violations of utility theory cannot be attributed to carelessness or momentary changes of heart. Rather, they reflect systematic tendencies shared by careful and intelligent people. The normative implications of these effects for the study of decision making in general and the conduct of decision analysis in particular are worthy of discussion.

First, both the certainty effect and the reference effect may be regarded as errors of preference. Although both effects are to be expected in certain situations, they are unacceptable from a normative standpoint. Nevertheless, they raise several theoretical and practical issues concerning the intricate interplay between descriptive and prescriptive theories of choice (Kahneman and Tversky, 1976).

The rationale for decision analysis rests on the fallibility of intuitive judgment. The concept of error in preference, however, is not treated explicitly in applied decision theory. Nevertheless, in order to justify the common procedures for measuring utility and subjective probability, one must assume that the observed violations of expected utility theory can be treated as random error. If the violations

are large and systematic rather than small and random, it is no longer possible to infer proper utilities and probabilities from choices between hypothetical options. No consistent utility function for wealth, for example, can be inferred from the choices of an individual who evaluates monetary outcomes as gains or losses relative to some reference point. Similarly, one cannot recover a proper subjective probability measure from the preferences of an individual who exhibits the certainty effect. The application of decision analysis, therefore, presupposes the descriptive validity of utility theory, at least as a first approximation. The existence of biases such as the certainty effect and the reference effect underscores the need for decision aids to help people make more consistent and rational choices. At the same time, these biases call into question the validity of the common procedures used in decision analysis to derive utilities and probabilities.

Much of the discussion of rationality in the context of utility theory focuses on the prescriptive validity of certain axioms, such as the substitution condition of von Neumann and Morgenstern or Savage's sure-thing principle. In these discussions, people usually agree on the definition of the consequences and disagree on the adequacy of various axioms. The classic argument between Allais (1953) and Savage (1954) is a case in point. Both Allais and Savage are willing to define the consequences in monetary terms; they differ in their opinion of the normative appeal of the sure-thing principle. It is my belief that the major normative issue is the legitimacy of the consequences, or the proper interpretation of the outcomes.

Consider the certainty effect (Allais's example) as a case in point. If one views the outcomes in terms of monetary gains, or number of lives lost, then the certainty effect is clearly untenable. If, on the other hand, one includes the regret associated with the failure to win the gamble (after giving up a sure gain) as part of the consequences, then the certainty effect becomes compatible with utility theory. Whether the certainty effect is rational, therefore, depends on the legitimacy of introducing consideration of regret. This problem, however, lies outside the scope of utility theory.

Consider next the reference effect. Economists and decision analysts tell us that utility for money should be defined over final asset positions and not over gains and losses. This proposition, however, does not follow from utility theory. If people actually experience the consequences as gains and losses relative to some reference point, should they not incorporate these experiences into their definition of consequences? If man is constructed in such a way that he is highly sensitive to gains and losses, then any attempt to maximize human welfare must recognize this fact.

One could argue, in return, that people are too sensitive to small changes around a reference point and that the formulation of decision problems in terms of terminal outcomes rather than gains and losses would improve the rationality of decisions. This argument is appealing, but it is important to recognize that it does not follow from utility theory. It tells people how they should feel, not what they should do.

Normative decision theory is formulated in terms of an abstract set of consequences that are the carriers of utilities. The axiomatic theory, by its very nature,

leaves the consequences uninterpreted. Thus, such a theory can instruct people how to maximize their utility functions; it cannot assist in the interpretation and the evaluation of the consequences. Unfortunately, there is probably as much irrationality in the interpretation and the evaluation of consequences as there is in the intuitive computation of expected utilities. In this respect, axiomatic utility theory provides only a partial analysis of the problem of rational choice. A comprehensive analysis of decision making should deal explicitly with the interpretation of outcomes, the justification of preferences, and the legitimacy of values. Such an analysis is likely to be explicative, or even therapeutic, rather than normative. To the best of my knowledge, no systematic analysis of this type is available.

REFERENCES

- Allais, M. 1953. Le comportement de l'homme rationnel devant le risque: critique des postulats et axiomes de l'école américaine. *Econometrica*, Vol. 21, pp. 503–546.
- Kahneman, D., and A. Tversky. 1976. Prospect theory: an analysis of decisions under risk. Unpublished manuscript. The Hebrew University, Jerusalem.
- Kalelkar, A.S., L.J. Partridge, and R.E. Brooks. 1974. *Decision Analysis in Hazardous Material Transportation*. Arthur D. Little, Inc., Cambridge, Massachusetts.
- Keeney, R.L., and H. Raiffa. 1976. *Decisions with Multiple Objectives*. John Wiley, New York.
- Savage, L.J. 1954. *The Foundations of Statistics*. John Wiley, New York.
- Swalm, R.O. 1966. Utility theory – insights into risk taking. *Harvard Business Review*, Vol. 44, pp. 123–136.
- Tversky, A., and D. Kahneman. 1974. Judgment under uncertainty: heuristics and biases. *Science*, Vol. 185, pp. 1124–1131.

DISCUSSION

MacCRIMMON: I would like to ask Dr. Tversky whether a certainty effect perhaps oversimplifies what is really going on. We have done some recent work that indicates that at least two parameters are related to this certainty effect – the magnitudes of the probabilities and the magnitudes of the consequences. Suppose you have two alternatives A and B . Alternative A yields \$1,000 with probability p and \$0 otherwise. Alternative B yields with probability p a gamble of a 0.8 chance at \$5,000 and a 0.2 chance at \$0 or a $1 - p$ chance at \$0. Let us start with $p = 1$: A yields a sure \$1,000 and B is a gamble. This is the kind of problem that Dr. Tversky is talking about, and we did indeed get results that are not consistent with utility axioms.

On the other hand, when p is equal to 0.05, alternative A results in \$1,000 with probability 0.05 and alternative B yields \$5,000 with probability 0.04. People perceive no significant difference between these probabilities. So rather than say certainty effect, I prefer to think of it as a kind of probability ratio. Our results show that the proportion of people choosing B depends on p .

If we increase the \$5,000 and \$1,000 up to millions, the proportion of people

choosing B still depends on p . However, the results indicate the proportion depends not only on p but also on the magnitude of the consequences. What I am interested in is the whole domain of magnitudes and probabilities. There seems to be a certainty effect, but there also seems to be some type of magnitude effect that is just as strong. We have obtained the same results for undesirable consequences. Is it really appropriate to call what is happening a certainty effect if you look just at one little piece of the domain? If you looked at the whole domain, maybe you would find more complicated effects operating that require explanation. For example, it might be that if you have gambles in only one part of the domain, then you are safe in applying utility theory. However, when you must evaluate lotteries with large differences in magnitude and probability, expected utility should be used with care.

TVERSKY: I agree with Dr. MacCrimmon that the certainty effect does not incorporate all violations of the substitution axiom. Nevertheless, it is probably one of the most common and significant departures from utility theory. I suspect that in the problems you studied, you get a sharp drop in the effect when you limit yourself to risky combinations. There, the substitution principle will hold, at least to a first approximation. The question raised by Dr. MacCrimmon is whether the certainty effect is large enough to justify treating it as a separate effect or whether it is a special case of something else. I think our data are not complete enough to decide.

TODA: There is another effect that is also very interesting. People are sometimes very serious about getting a \$1 discount when they are buying \$10 items, but they usually do not ask for a \$1 discount when they buy a car or a house. This is usually explained by the flat utility over that area, but I just don't believe it. As Dr. Tversky said, man is very sensitive to differences. I think that not only is the zero point calibrated against the status quo, but also the full range of an attribute is calibrated against the possible alternatives.

TVERSKY: I think that the effect described by Dr. Toda is a special case of the reference effect. It follows from the fact that the marginal utility decreases with the difference from the reference point.

TODA: I understood that by the reference effect you meant only the origin. I am suggesting that the reference point for the utility is also important.

KULIKOWSKI: My argument is much the same as Dr. Toda's. I think there is a danger that we are trying to generalize too much from some experimental facts. You found that some people were more sensitive to losses than to gains. It is not a general situation; it is possible to give examples where the opposite happens. I think this is a very interesting approach to finding out what the real structure of one's utility is. My feeling is that this is something very individual. Maybe we should think about the mechanisms that motivate different attitudes.

FISHBURN: I have become aware recently of a number of S-shaped utility curves that have been published in the literature. One of the things we find in many of these situations is that the individual involved is satisfied by some kind of an

expectation, a target level that he would like to meet. This might be something that is set by his firm, like a 20 percent return, and in almost all cases the utility functions show a sharp break in form at a point that the financial economists have labeled the target point. Sometimes below the target you observe that this phenomenon swamps things so that risk-seeking might be inferred. I think there is a reasonable and very rational explanation for some of these breaks in the curves with regard to this target or reference point.

In some situations I think there is the additional variable of individual preferences. This might be labeled embarrassment about falling below the target level. If the decision maker has a chance of falling below the target level, he will take unfavorable gambles in order to avoid looking as bad as he might otherwise. Above the target he may be risk averse.

KEENEY: Let me expand on Dr. Fishburn's point that there may be an additional attribute in the problem. Let us define attribute X as income and attribute Y as degree of embarrassment. The consequences (x, y) here are described by two levels, the amount of money x and degree of embarrassment y . I might find that any conditional utility function $u(x, y')$ over the income levels, holding the degree of embarrassment fixed at y' , would have a nice risk-averse form. The fact is that when my x level changes in a consequence (x, y) , then my y automatically changes. There is a strong correlation of x and y levels in the consequences. Perhaps the correlation is even one-to-one, meaning y is a function of x , call it $f(x)$. If I originally structure the problem in one variable, namely income, the utility function over X is really the utility function $u[x, f(x)]$ over the consequences $(x, y) = [x, f(x)]$. I think that this can sometimes be an explanation of the certainty effect.

MEYER: In many cases, I accept the explanation that Dr. Fishburn suggested, which is that the real consequence is not the one that you are talking about. The decision maker is looking at the discomfort of not meeting a target. Perhaps the best example is a businessman's utility function for assets or earnings. When you cover a range that includes bankruptcy, you can show that a businessman who is, however you ask the questions, risk averse when business is as normal, becomes terribly risk-seeking when he is near the danger of bankruptcy. Now that makes good sense, since he has no more than everything to lose. The real consequences are that his business goes bankrupt, and it doesn't matter whether it goes bankrupt with a loss of \$100,000 or \$100,000,000. There is an artificial scale for large negative losses. The same is true for the public servant who is concerned with traffic accidents. It doesn't probably matter very much to him in terms of his public position whether the consequences that he is engaged in are 100 more traffic deaths a year or 300 more traffic deaths a year. He fails in either case and loses his job.

The scale with which failure should be measured is not the scale with which you are asking the questions. Why do we have to try to explain those phenomena that you have discussed in terms of reference effects or certainty effects that are measured on just one scale, a single attribute? Shouldn't we be willing to investigate them with more than one attribute?

TVERSKY: There are many instances in which an S-shaped utility function doesn't make sense, as in the case of the expert who assessed the utility function for society. It is dangerous to defend such utility functions simply because in another context a similar function could be defended.

There are two main possibilities for accounting for the certainty effect. One, followed by Kahneman and myself, is to introduce uncertainty weights instead of subjective probabilities and thereby abandon the expectation principle. The second possibility, suggested by Dr. Keeney and Dr. Meyer, is to introduce an additional attribute. This is, in part, a strategic problem: which approach is likely to produce better results? It is my belief that one could develop an adequate descriptive theory of choice by generalizing the expectation property, without introducing additional attributes in an *ad hoc* fashion.

10 A Dynamic Consumption Model and Optimization of Utility Functionals

R. Kulikowski

10.1 INTRODUCTION

There is a vast amount of literature that approaches consumer behavior in terms of multiple objectives or utility functions. Most of the work done in the field concentrates on the static situation that exists when the utility of a given commodity is an instantaneous function of expenditures or, in other words, when commodities purchased in the past have no influence on the present utility. This, however, is not the case when one considers consumer expenditures for durable goods or government expenditures in the fields of education, health, welfare, environmental protection, and so on. In these cases, it is possible to introduce a dynamic consumption model using a dynamic utility functional.

This paper has been motivated by the research concerned with the construction of a complex, long-range, national development model. The model – MRI¹ – is being constructed at the Institute of Organization and Management of the Polish Academy of Sciences. It consists of three main submodels: production, consumption, and environment. The consumption submodel is characterized by the utility function with parameters that are estimated on the basis of past statistical data. It takes into account the utility structure changes caused by GNP per capita and the change in price indices. The model is normative, in the sense that one can investigate the national growth path that would result from alternative development strategies in terms of productive investment and government expenditures in such fields as education, R&D, health service, and pollution control. [For more details concerning the MRI methodology, see Kulikowski (1973, 1975a, b).]

The optimal investment strategies for MRI have already been derived (Kulikowski, 1975a,b). In the present paper, an effort is made to derive the optimal consumer and government expenditure strategies – those that maximize the utility functional.

¹ Model Rozwoju numer I (Development model no. I).

10.2 DYNAMIC CONSUMPTION MODELS

Consider a single (or aggregated) consumer having at his disposal in the time interval $[0, T]$ the given amount of financial resources Z . The financial resources, generally speaking, consist of salaries, savings, and the like. It is assumed also that the consumer can obtain a loan in order to realize the dynamic consumption strategy in $[0, T]$ should the demands of that strategy exceed his salary in certain subsets of $[0, T]$. He is supposed, however, to pay back the loan (together with interest) before the end of T interval.

Assume also that the consumer's overall utility function $U(x)$, $x \in \Omega$, where Ω is a given subset of N -dimensional space E^n , is given. It is well known (see Chipman, 1960; Fishburn, 1970) that $U(x)$ is a real-valued, order-preserving vector function. However, to be more specific, we shall deal with the widely used function¹

$$U(x) = U_0 \prod_{i=1}^N x_i^{\beta_i}, \quad (10.1)$$

where $U_0, \beta_i, i = 1, 2, \dots, N$ are given positive constants, and

$$\sum_{i=1}^N \beta_i \leq 1. \quad (10.2)$$

Assume that $x_i, i = 1, \dots, N$ represents the consumer's component utility levels, which are related to the expenditure intensity $y_i(t), t \in [0, T], i = 1, \dots, N$ in an inertial and nonlinear fashion (for convenience, rather than general methodology, we shall deal with continuous instead of discrete time variables):

$$x_i(t) = \int_0^t k_i(t, \tau) [y_i(\tau)]^{\alpha_i} d\tau, \quad (10.3)$$

where $k_i(t, \tau)$ = given nonnegative function, $k_i(t, \tau) = 0$ for $t < \tau$; and α_i = given positive number less unity. A typical example of $k_i(t, \tau)$ is the stationary [i.e., $k_i(t, \tau) = k_i(t - \tau)$] delayed exponential function, i.e.,

$$\begin{aligned} k_i(t) &= A_i e^{-\delta_i(t-T_i)}, & t > T_i, \\ &= 0, & t < T_i. \end{aligned}$$

In the last case, the consumer expenditures create no utility before $t = T_i$. Such a situation happens, for example, in education and health expenditures. For instance, in order to command a better salary, the consumer must finish school, which will cost him $y_i(t)$ in money and T_i in years of study.

It should be observed that, because of the exponent $-\delta_i t$, the utility level (i.e., the health or training level) decreases with time if no additional expenditures are incurred.

¹ That function has also been adopted in the first version MRI models. An extension of Equation (10.1) to the CES (constant elasticity of substitution) function is also possible.

If no dynamic effects are present, (i.e., when the change in expenditure results in an immediate change of utility), one can write formally $k_i(t) = A_i \delta(t)$ [where $\delta(t)$ is the Dirac's unitary pulse] and get

$$x_i(t) = A_i [y_i(t)]^{\alpha_i}.$$

(A more elegant notation based on distribution theory can also be used here. In that case $\delta(t)$ can be regarded as a linear functional.)

It should also be observed that, because $0 < \alpha_i < 1$, there is a "decreasing return to scale" effect in (10.3) that corresponds to saturation of utility level (e.g., the training or health level) with respect to increase of expenditures.

Since x_i , $i = 1, \dots, N$ are generally functions of time, it is necessary to deal with the time-averaged utility,

$$\bar{U}(y) = \int_0^T w(t) U(x) dt, \quad (10.4)$$

where $w(t)$ = given discount function, such as $w(t) = (1 + r)^{-t}$ (r = discount rate); and $\bar{U}(y)$ is a nonlinear function with respect to the vector function $y(t) = \{y_1(t), y_2(t), \dots, y_N(t)\}$, $t \in [0, T]$.

In the model being discussed, we do not take into account the effects caused by past expenditures, i.e., the expenditures for $t < 0$. One possible way of taking these expenditures into account is to replace (10.3) by

$$x_i(t) = \bar{x}_i(t) + \int_0^t k_i(t, \tau) [y_i(\tau)]^{\alpha_i} d\tau, \quad (10.5)$$

where

$$\bar{x}_i(t) = \int_{-\infty}^0 k_i(t, \tau) [y_i(\tau)]^{\alpha_i} d\tau$$

represents the utility of commodities purchased in the past.

In order to derive the optimal consumption strategy, one should maximize (10.4), subject to the monetary constraints:

$$\sum_{i=1}^N \int_0^T w_i(t) y_i(t) dt \leq Z, \quad (10.6)$$

$$y_i(t) \geq 0, t \in [0, T], i = 1, \dots, N, \quad (10.7)$$

where $w_i(t)$ = weights or interest functions [when loans are used, one can assume $w_i(t) = (1 + E_i)^{T-t}$ (E_i = interest rate)]; and Z = total consumer financial resources.

The present model can be used mainly for investigation of the behavior of the single (or aggregated) consumer only. In the case of macromodeling of centrally planned economies, one can use the following extension of the present model.

Let there be n different consumer classes, each described by the utility

$$U_i(y_i) = U_{0i} \int_0^T \prod_{\nu=1}^N \left\{ \int_0^t k_{\nu i}(t - \tau) [y_{\nu i}(\tau)]^{\alpha_{\nu}} d\tau \right\}^{\beta_{\nu}} W(t) dt, \quad (10.8)$$

where $U_{0i} > 0$, $\alpha_{\nu} \in (0, 1)$, $\sum_{\nu=1}^N \beta_{\nu} = 1$; and $k_{\nu i}(t)$ = nonnegative functions.

The expenditure intensities $y_{\nu i}(t)$ should satisfy the following constraints:

$$\sum_{i=1}^n Z_{\nu i} \leq Z_{\nu}, Z_{\nu i} = \int_0^T w_{\nu}(t) y_{\nu i}(t) dt, \nu = 1, \dots, N \quad (10.9)$$

and

$$y_{\nu i}(t) \geq 0, t \in [0, T], i = 1, \dots, n, \nu = 1, \dots, n, \quad (10.10)$$

where $Z_{\nu i}$ is the expenditure of i th consumer class for ν th commodity.

In the present model Z_1 may represent aggregated consumer private expenditures (out of his salary) while Z_2, \dots, Z_N represents government expenditures in such fields as education, health, social care, and environment. The expenditures Z_2, \dots, Z_N can be regarded as the government contribution to the social welfare. The government recognizes here that the utility functionals are different for different classes of consumers, and it tries to allocate the financial resources (by means of differentiating salaries, medical and social care, and the like) so as to maximize utility. For example, the government may compensate miners for their hard work by improving their medical and social care.

The problem of optimization of consumption strategy consists of finding $y_{\nu i}(t) = \hat{y}_{\nu i}(t), i = 1, \dots, n, \nu = 1, \dots, N$, such that the functional

$$U(y) = \sum_{i=1}^n U_i(y_i) \quad (10.11)$$

attains a maximum subject to constraints (10.9) and (10.10).

It should be observed that in the consumption model under discussion a decentralized system of consumption strategies has been adopted. According to this system, the government is concerned with the best allocation of Z among N different spheres of activity, while each individual consumer is concerned with the best allocation of his salary (represented by Z_{1i} , for instance).

10.3 SOLUTION OF THE OPTIMIZATION PROBLEM

In order to solve the problem, the following notation is introduced:

$$z_{\nu i}(t) = [y_{\nu i}(t)]^{\alpha_{\nu}}, \nu = 1, \dots, N, i = 1, \dots, n.$$

It is convenient to consider first the single-consumer model [(10.1) to (10.6)].

In the present case, we can drop the i index in (10.8) through (10.11), and our problem becomes that of finding the nonnegative strategies $z_{\nu}(t) = \hat{z}_{\nu}(t), \nu = 1, \dots, N$, which maximize the functional

$$Y = \int_0^T \prod_{\nu=1}^N f_{\nu}(z_{\nu}) dt, \quad (10.12)$$

where

$$f_\nu(z_\nu) = \left\{ \int_0^t k_\nu(t-\tau) z_\nu(\tau) d\tau \right\} \beta_\nu, \quad \sum_{\nu=1}^N \beta_\nu = 1,$$

subject to

$$\int_0^T w_i(\tau) [z_i(\tau)]^{1/\alpha_i} d\tau \leq Z_i, \quad i = 1, \dots, N. \quad (10.13)$$

In order to solve the present problem, one can apply the generalized Hölder inequality

$$Y = \int_0^T \prod_{\nu=1}^N f_\nu(\tau) d\tau \leq \prod_{\nu=1}^N \left\{ \int_0^T f_\nu^{1/\beta_\nu}(\tau) d\tau \right\}^{\beta_\nu},$$

which becomes an equality if and only if (as is true almost always)

$$c_1 f_1^{1/\beta_1}(\tau) = c_i f_i^{1/\beta_i}(\tau), \quad \tau \in [0, T], \quad i = 1, \dots, N, \quad (10.14)$$

where $c_i = \text{constant}$ and $i = 1, \dots, N$. In that case, one obtains

$$\begin{aligned} Y &\leq \prod_{i=1}^N \left[(c_1/c_i)^{\beta_i} \int_0^T dt \int_0^t k_1(t-\tau) z_1(\tau) d\tau \right] \\ &= \prod_{i=1}^N (c_1/c_i)^{\beta_i} \int_0^T z_1(\tau) d\tau \int_\tau^T k_1(t-\tau) dt. \end{aligned} \quad (10.15)$$

Again applying the Hölder inequality, we get

$$\begin{aligned} Y &\leq \prod_{i=1}^N (c_1/c_i)^{\beta_i} \left\{ \int_0^T w_1(\tau) [z_1(\tau)]^{1/\alpha_1} d\tau \right\}^{\alpha_1} \\ &\quad \cdot \left\{ \int_0^T \left[w_1(t)^{-\alpha_1} \cdot \int_\tau^T k_1(t-\tau) dt \right]^{1/(1-\alpha_1)} d\tau \right\}^{1-\alpha_1}, \end{aligned}$$

where the equality appears if and only if (as is true almost always)

$$\hat{z}_1(t) = c \bar{z}_1(t), \quad \bar{z}_1(t) = \left[w_1^{-1}(\tau) \int_\tau^T k_1(t-\tau) dt \right]^{1/(1-\alpha_1)}. \quad (10.16)$$

The value of c can be derived by using (10.13), yielding

$$c = \left\{ \frac{Z_1}{\int_0^T w_1(\tau) [\bar{z}_1(\tau)]^{1/\alpha_1} d\tau} \right\}^{\alpha_1}.$$

Then

$$\begin{aligned}
 Y(\hat{z}) &= \prod_{i=1}^N (c_1/c_i)^{\beta_i} Z_1^{\alpha_1} \left\{ \int_0^T w_1(\tau) \right. \\
 &\quad \cdot \left. \left[w_1^{-1}(\tau) \int_{\tau}^T k_1(t-\tau) dt \right]^{1-\alpha_1} d\tau \right\}^{1-\alpha_1} \\
 &= \prod_{i=1}^N \left(c \frac{c_1}{c_i} \right)^{\beta_i} \int_0^T w_1(\tau) [\bar{z}_1(\tau)]^{1/\alpha_1} d\tau. \quad (10.17)
 \end{aligned}$$

The optimal strategies $\hat{z}_i(t)$, $i = 2, \dots, N$, can be derived by using (10.14)¹, which can be transformed to an equivalent form, assuming the Laplace transformations

$$\begin{aligned}
 K_i(p) &= L\{k_i(t)\}, Z_i(p) = L\{z_i(t)\}, Z_1(p) = cK_1^*(p), \\
 K_1^*(p) &= L \left\{ w_1^{-1}(\tau) \int_{\tau}^T k_1(t-\tau) dt \right\}^{1-\alpha_1}
 \end{aligned}$$

exist.

Then

$$c_1 K_1(p) \hat{Z}_1(p) = c_1 c K_1(p) K_1^*(p) = c_i K_i(p) \hat{Z}_i(p),$$

and

$$\hat{Z}_i(p) = \frac{cc_1 K_1(p) K_1^*(p)}{c_i K_i(p)}, i = 2, \dots, N,$$

or

$$\hat{z}_i(t) = c \frac{c_1}{c_i} \bar{z}_i(t),$$

where

$$\bar{z}_i(t) = L^{-1} \left\{ \frac{K_1^*(p) K_1(p)}{K_i(p)} \right\}.$$

Using the conditions (10.13), we get

$$\hat{z}_i(t) = \left\{ \frac{Z_i}{\int_0^T w_i(t) [\bar{z}_i(t)]^{1/\alpha_i} dt} \right\}^{\alpha_i} \bar{z}_i(t), i = 1, \dots, N, \quad (10.18)$$

and – instead of (10.17) – we obtain

$$Y(\hat{z}) = G^q \prod_{\nu=1}^N Z_{\nu}^{\alpha_{\nu} \beta_{\nu}}, q = 1 - \sum_{\nu=1}^N \alpha_{\nu} \beta_{\nu}, \quad (10.19)$$

where

$$\begin{aligned}
 G &= \left\{ \int_0^T w_1(\tau) [\bar{z}_1(\tau)]^{1/\alpha_1} d\tau \right\}^{1/q} \\
 &\quad \cdot \prod_{\nu=1}^N \left\{ \int_0^T w_{\nu}(\tau) [\bar{z}_{\nu}(\tau)]^{1/\alpha_{\nu}} d\tau \right\}^{-\alpha_{\nu} \beta_{\nu}/q}.
 \end{aligned}$$

¹It can be shown that, in order to solve (10.14), the index $i = 1$ should be assigned to the most inertial production factor specified by the set of $\{K_i(p)\}$.

The solution obtained can also be used for the utility functions with noninertial factors. In the simplest case, $N = 2$, when

$$Y = \int_0^T \left\{ \int_0^t k_1(t-\tau) z_1(\tau) d\tau \right\}^\beta [z_2(t)]^{1-\beta} dt,$$

one can use (10.18), setting $k_2(t) = \delta(t) [K_2(p) = 1]$. The form of the solution in the present case coincides with the result obtained by Kulikowski (1975a).

The results obtained so far can easily be extended to the general model described in (10.8) through (10.11). We shall assume that all the expenditures in the ν th sphere of activity (Z_ν) are given and that they should be allocated among consumers (so that $Z_{\nu i}$ represents the amount of ν th expenditure for the i th consumer) in such a way that the following relation holds:

$$\sum_{i=1}^n Z_{\nu i} \leq Z_\nu, \nu = 1, \dots, N. \quad (10.20)$$

Taking into account (10.19), the consumer utility functions can be written as

$$Y_i = G_i^q \prod_{\nu=1}^N Z_{\nu i}^{\alpha_\nu \beta_\nu}, \quad (10.21)$$

where

$$q = 1 - \sum_{\nu=1}^N \alpha_\nu \beta_\nu, i = 1, \dots, n,$$

$$G_i = \left\{ \int_0^T w_1(\tau) [\bar{z}_{1i}(\tau)]^{1/\alpha_1} d\tau \right\}^{1/q}$$

$$\cdot \prod_{\nu=1}^N \left\{ \int_0^T w_\nu(\tau) [\bar{z}_{\nu i}(\tau)]^{1/\alpha_\nu} d\tau \right\}^{-\alpha_\nu \beta_\nu / q}.$$

Then the problem of optimum allocation of Z_ν , $\nu = 1, \dots, N$, among the n consumers can be formulated as follows: Find the nonnegative $Z_{\nu i} = \hat{Z}_{\nu i}$, $\nu = 1, \dots, N$, $i = 1, \dots, n$, such that

$$\bar{Y} = \sum_{i=1}^n G_i^q \prod_{\nu=1}^N Z_{\nu i}^{\alpha_\nu \beta_\nu}$$

attains maximal value, subject to (10.20).

The solution to this problem (see Kulikowski, 1975b) is unique and assumes the following form:

$$\hat{Z}_{\nu i} = (G_i/G) Z_\nu, \quad \nu = 1, \dots, N, i = 1, \dots, n, \quad (10.22)$$

where

$$G = \sum_{i=1}^n G_i$$

and

$$\bar{Y}(\hat{z}_{\nu i}) = G_i^q \sum_{\nu=1}^N Z_\nu^{\alpha_\nu \beta_\nu}. \quad (10.23)$$

The consumer's dynamic strategies $\hat{z}_{\nu i}(t)$, $\nu = 1, \dots, N$, $i = 1, \dots, n$, can be derived by use of (10.18):

$$\hat{z}_{\nu i}(t) = \left\{ \frac{\hat{Z}_{\nu i}}{\int_0^T w_i(t) [\bar{z}_{\nu i}(t)]^{1/\alpha_i} dt} \right\}^{\alpha_i} \bar{z}_{\nu i}(t),$$

$$\nu = 1, \dots, N, i = 1, \dots, n, \quad (10.24)$$

where

$$\bar{z}_{\nu i}(t) = L^{-1} \left\{ \frac{K_{1i}^*(p) K_{1i}(p)}{K_{\nu i}(p)} \right\},$$

$$K_{\nu i}(p) = L\{k_{\nu i}(t)\}, K_{1i}(p) = L\{k_{1i}(t)\},$$

$$K_{1i}^*(p) = L \left\{ w_1^{-1}(\tau) \int_{\tau}^T k_{1i}(t - \tau) dt \right\}^{\alpha_i / (1 - \alpha_i)}.$$

Now it is also possible to solve explicitly the problem of optimal allocation of total consumption Z generated by the economy among the different spheres of activity represented by the expenditures Z_{ν} , $\nu = 1, \dots, N$. In other words, one would like to find the nonnegative values $Z_{\nu} = \hat{Z}_{\nu}$, $\nu = 1, \dots, N$, such that the aggregated utility described by (10.23) attains a maximum subject to the constraint $\sum_{\nu=1}^N Z_{\nu} \leq Y^*$.

The unique solution of that problem becomes

$$Z_{\nu} = \gamma_{\nu} Y^* = \frac{\alpha_{\nu} \beta_{\nu}}{\sum_{\nu=1}^N \alpha_{\nu} \beta_{\nu}} Y^*, \nu = 1, \dots, N. \quad (10.25)$$

It can be shown that the strategy outlined in (10.25) also maximizes the resulting utility function:

$$U = \bar{U} \prod_{\nu=1}^N Z_{\nu}^{\gamma_{\nu}}, \bar{U} = \text{constant}$$

10.4 CONCLUSIONS

In the dynamic consumption model described by (10.1) through (10.11), there is an optimal strategy of allocation of expenditures. This unique strategy can be derived explicitly by use of (10.22), (10.24), and (10.25).

As already mentioned, the model discussed can be used for long-term modeling of the consumption sector of the normative model of national development MRI. In particular, it can be used for planning of the allocation of resources in the sphere of aggregate consumption (i.e., the government expenditures in health, education, and the like) of a planned economy.

The model can also be used to explain the individual consumer's expenditure strategy, during the life-span. For example, it can be shown (Kulikowski, 1975) that the optimum expenditures for durable goods (such as housing and education)

decrease with time, while expenditures for immediate consumption goods increase. This behavior cannot be explained by a static consumption model. In the dynamic model the "investments" at the end of the optimization interval do not pay, and the consumer's strategy is understandable.

REFERENCES

- Chipman, J.S. 1960. The foundations of utility. *Econometrica*, Vol. 28, pp. 193–224.
- Fishburn, P.C. 1970. *Utility Theory of Decision Making*. John Wiley, New York.
- Kulikowski, R. 1973. Modelling and optimum control of complex environment systems. *Control and Cybernetics*, No. 1–2, pp. 15–47.
- Kulikowski, R. 1975a. Decentralized management and optimization of development in large production organization. *Control and Cybernetics*, No. 1, pp. 5–18.
- Kulikowski, R. 1975b. Modelling and optimization of complex development. *Bulletin de l'Academie Polonaise des Sciences*, pp. 68–79.

DISCUSSION

MEYER: In your objective function you integrate over time for a given commodity and then multiply over all commodities. If you were to exchange the time and commodity subscripts, you would be multiplying single period functions over all commodities. I think perhaps your analysis would be unaltered. That seems to be worth investigating.

KULIKOWSKI: Yes, I believe that's correct.

RAIFFA: Leaving aside the mathematics of how to do it, the model very much looks like the capitalist models, where you have to consider benefits and costs in several time periods.

KULIKOWSKI: The overall goal is to allocate resources in the most efficient way – to maintain an efficient economy. From this point of view, we take a normative approach. It starts with the utility functional.

11 State-Dependent Time Preference

Richard F. Meyer

11.1 STATE-DEPENDENT UTILITIES

The consequences of a decision are often spread out over time, sometimes over very long periods of time: for example, the stream of income and cash flow due to a long-term investment; the stream of personal consumption due to a career decision; and the stream of environmental quality measures due to a plant-siting decision. In all these cases it is natural to divide time into discrete periods (e.g., months or years). Let us denote by $x = (x_1, x_2, \dots, x_n)$ a time-stream of consequences, where x_i refers to the consequences in period i .

Since most problems in which temporal considerations are important involve long periods of time, they also involve considerable uncertainty. Hence we would like to obtain a von Neumann–Morgenstern utility function $u(x)$ for the stream x . The expectation of u can then be used when making decisions under uncertainty.

A number of results have been derived (see Meyer, 1970; Richard, 1972; and Oksman, 1974) which allow us to structure the multiperiod utility function u in terms of single-period functions, using a variety of utility-independence assumptions. These utility-independence assumptions require that no preference-learning take place – e.g., that the consumption levels we are to enjoy in the near future will in no way affect our preferences for consumption in the distant future. Since this is in many cases too gross an assumption, this paper explores the implications of allowing state-dependent preferential learning.

For the sake of concreteness, let us confine ourselves to the example of a person's preference for his consumption stream $c = (c_1, c_2, \dots, c_n)$. We shall sometimes wish to think of c_n as the legacy, and we may wish to partition the entire stream into a "past" and a "future" relative to time m according to $\bar{c}_m = (c_1, c_2, \dots, c_m)$ and $\vec{c}_m = (c_m, c_{m+1}, \dots, c_n)$, where $m = 1, 2, \dots, n$. Alternatively, we may think of \bar{c}_m as the "near" future (if "now" is just before period 1) and of \vec{c}_m as the "distant" future. Lowercase letters will denote actual consumption levels, and

uppercase letters the corresponding attribute “consumption.” For example, c_i is the level in period i of the attribute C_i , which we think of as “period- i consumption.”

Our aim is to structure a von Neumann–Morgenstern utility $u(c)$ that allows experiential adaptation of preferences. Most multivariate structures derived for $u(c)$ have assumed that decisions about the “distant” future \vec{C}_{t+1} are utility-independent from those about the “immediate” future \vec{C}_t for all $1 \leq t < n$. Yet in many cases we would not expect people to act in so super-rational a manner. For example, we may become accustomed to the standard of living recently experienced and adjust our aspiration levels and the scale of our risk aversion so as to conform to this recent experience. Or we may feel that we appreciate a high standard of living more after a period of relative deprivation and that we mind a (temporary) low standard of living less when we know that it will be followed by a period of affluence. These are all examples of utility dependence: our preferences for the future are affected by our past experience, or our preferences for the immediate future depend on what the distant future holds in store. This paper focuses on the special utility structures appropriate in such cases.

11.2 EFFICIENT BACKWARD AND FORWARD STATE DESCRIPTORS

Consider $u(\vec{c}_t, \vec{c}_{t+1})$ as a utility function for \vec{C}_{t+1} (“the future”) when \vec{C}_t (“the past”) is given. Since \vec{C}_{t+1} is utility-dependent on \vec{C}_t (i.e., the past *does* matter), $u(\vec{c}_t, \vec{c}_{t+1})$ when viewed as a function of \vec{c}_{t+1} is not strategically equivalent to $u(\vec{c}'_t, \vec{c}_{t+1})$ for all \vec{c}'_t . Another way of saying this is to observe that our utility for \vec{c}_{t+1} may be affected by certain features of the past, although not necessarily by all the detail contained in the full description of the past, \vec{c}_t . It is therefore natural to introduce a state descriptor of the past, $\vec{s}_t(\vec{c}_t)$, where $\vec{s}_t(\cdot)$ may itself be vector-valued (although presumably of lower dimension than \vec{c}_t) and where it has the property that two different pasts, \vec{c}_t and \vec{c}'_t , which have the same \vec{s}_t [i.e., $\vec{s}_t(\vec{c}_t) = \vec{s}_t(\vec{c}'_t)$], will lead to strategically equivalent utilities for the future. We may then regard the conditional utility of \vec{C}_{t+1} given \vec{C}_t as a function of \vec{s}_t instead of \vec{c}_t , and we shall denote it as $\vec{u}_{t+1}(\vec{c}_{t+1} | \vec{s}_t(\vec{c}_t))$ – that is, the “forward” utility for streams starting in period $t + 1$.

Thus far we have required only that $\vec{s}_t(\cdot)$ be a more economical description of the past than \vec{c}_t , but that it still be adequate for decisions regarding \vec{c}_{t+1} . Now we want to ask that $\vec{s}_t(\cdot)$ be in some sense *as economical a descriptor as possible* for this purpose. We therefore define $\vec{s}_t(\cdot)$ to be an *efficient* backward state descriptor if and only if for any past state \vec{s}_t the strategic equivalence of $\vec{u}_{t+1}(\cdot | \vec{s}_t)$ and $\vec{u}_{t+1}(\cdot | \vec{s}'_t)$ implies that $\vec{s}_t = \vec{s}'_t$. Another way of stating this is to require that *all* \vec{c}_t that lead to strategically equivalent (with respect to \vec{C}_{t+1}) $u(\vec{c}_t, \cdot)$ be assigned the same \vec{s}_t .

Suppose we have introduced efficient backward state descriptors at times

$t-1$ and t . We may then prove the following important theorem, which asserts the *updatability* of efficient state descriptors.

THEOREM 1 If $\bar{s}_{t-1}(\cdot)$ and $\bar{s}_t(\cdot)$ are both efficient backward state descriptors, then $\bar{s}_t(\cdot)$ is a function of \bar{s}_{t-1} and c_t only.

Observe that \vec{u}_{t+1} and \vec{u}_t must for a given stream \vec{c}_t be strategically equivalent for decisions regarding \vec{c}_{t+1} . Symbolically, this implies that

$$\vec{u}_t(c_t, \vec{c}_{t+1} | \bar{s}_{t-1}) = a(c_t, \bar{s}_{t-1}, \bar{s}_t) + b(c_t, \bar{s}_{t-1}, \bar{s}_t) \vec{u}_{t+1}(\vec{c}_{t+1} | \bar{s}_t), \quad (11.1)$$

where $a(\cdot)$ and $b(\cdot)$ may depend on anything other than \vec{c}_{t+1} . Now suppose \bar{s}_t were not a function of \bar{s}_{t-1} and c_t only – in other words, suppose that we can change \vec{c}_{t-1} in such a way that \bar{s}_{t-1} is kept constant but \bar{s}_t changes (without changing c_t) to \bar{s}'_t . In that case (11.1) implies that

$$\vec{u}_t(\vec{c}_{t+1}) = a(\bar{s}_t) + b(\bar{s}_t) \vec{u}_{t+1}(\vec{c}_{t+1} | \bar{s}_t) \quad (11.2a)$$

$$= a(\bar{s}'_t) + b(\bar{s}'_t) \vec{u}_{t+1}(\vec{c}_{t+1} | \bar{s}'_t), \quad (11.2b)$$

where we have suppressed the dependence on c_t and \bar{s}_{t-1} since they are kept constant in (11.2). Equating (11.2a) and (11.2b) shows that $\vec{u}_{t+1}(\vec{c}_{t+1} | \bar{s}_t)$ and $\vec{u}_{t+1}(\vec{c}_{t+1} | \bar{s}'_t)$ are strategically equivalent. But if $\bar{s}_t(\cdot)$ is efficient, this implies that $\bar{s}_t = \bar{s}'_t$, which is contrary to our initial assumption that \vec{c}_{t-1} could be changed (while holding c_t constant) so as to hold \bar{s}_{t-1} constant but to change \bar{s}_t . Hence $\bar{s}_t = f_t(c_t, \bar{s}_{t-1})$.

The above argument was presented for backward state descriptors, but a completely analogous line of reasoning applies to forward state descriptors, $\vec{s}_{t+1}(\vec{c}_{t+1})$, which permit a less detailed, more economical description of the distant future to serve as a conditioning variable for decisions affecting only the near future \vec{c}_t . Again, we may introduce the notion of an efficient descriptor: i.e., $\vec{s}_{t+1}(\cdot)$ is efficient if, when $\vec{u}_t(\vec{c}_t | \vec{s}_{t+1})$ and $\vec{u}_t(\vec{c}_t | \vec{s}'_{t+1})$ are strategically equivalent, then $\vec{s}_{t+1} = \vec{s}'_{t+1}$. Again an updatability theorem follows: \vec{s}_t is a function of c_t and \vec{s}_{t+1} only.

11.3 UTILITY STRUCTURES RESULTING FROM EFFICIENT STATE DESCRIPTORS

Let $t < t'$ be two instants of time that divide all of time into three parts: a “past” \vec{c}_t prior to t ; a “present” from t to t' that we shall denote by $c_{t,t'} = (c_{t+1}, \dots, c_{t'})$; and a “future” $\vec{c}_{t'+1}$ from t' on. Clearly, it would be desirable if decisions regarding $c_{t,t'}$ could be based on efficient state descriptors for \vec{c}_t and $\vec{c}_{t'+1}$ when such state descriptors exist. The following theorem shows that this is indeed the case.

THEOREM 2 Let \vec{s}_t and \vec{s}_{t+1} be backward and forward state descriptors for decisions regarding \vec{c}_{t+1} and \vec{c}_t , respectively. There will then exist a utility function $u_{t,t'}(c_{t,t'} | \vec{s}_t, \vec{s}_{t+1})$ that is strategically equivalent to $u(c)$ for decisions regarding $c_{t,t'}$ only.

Proof To prove this theorem, we first observe that both \vec{u}_{t+1} and \vec{u}_t may be used to make decisions regarding $c_{t,t'}$, and hence they must be strategically equivalent for such decisions. Let $c_{t,t'}^0$ and $c_{t,t'}^*$ denote, respectively, any least and most desirable "presents," for a given past \vec{c}_t and future \vec{c}_{t+1} . Note that $c_{t,t'}^0$ and $c_{t,t'}^*$ can depend¹ on \vec{c}_t and \vec{c}_{t+1} only through \vec{s}_t and \vec{s}_{t+1} .

Hence we may normalize \vec{u}_{t+1} and $u_{t'}$ for decisions regarding $c_{t,t'}$ between $c_{t,t'}^0$ and $c_{t,t'}^*$ and equate both to $u_{t,t'}$:

$$u_{t,t'} = \frac{\vec{u}_{t+1}(c_{t,t'}, \vec{c}_{t+1} | \vec{s}_t) - \vec{u}_{t+1}(c_{t,t'}^0, \vec{c}_{t+1} | \vec{s}_t)}{\vec{u}_{t+1}(c_{t,t'}^*, \vec{c}_{t+1} | \vec{s}_t) - \vec{u}_{t+1}(c_{t,t'}^0, \vec{c}_{t+1} | \vec{s}_t)} \quad (11.3a)$$

$$= \frac{\vec{u}_t(\vec{c}_t, c_{t,t'} | \vec{s}_{t+1}) - \vec{u}_t(\vec{c}_t, c_{t,t'}^0 | \vec{s}_{t+1})}{\vec{u}_t(\vec{c}_t, c_{t,t'}^* | \vec{s}_{t+1}) - \vec{u}_t(\vec{c}_t, c_{t,t'}^0 | \vec{s}_{t+1})}. \quad (11.3b)$$

Since (11.3b) depends on \vec{c}_t , but (11.3a) depends on the past only through \vec{s}_t , it follows that changes in \vec{c}_t that leave \vec{s}_t unchanged cannot affect $u_{t,t'}$, so that $u_{t,t'}$ depends on the past only through \vec{s}_t . Similarly, since (11.3b) depends on the future only through \vec{s}_{t+1} , it follows that $u_{t,t'}$ can depend only on the forward state variable, which completes the proof of Theorem 2.

When the state descriptors are efficient, they impose a great deal of additional structure on the utility for a stream. Suppose that for some value of t we knew efficient backward and forward state descriptors \vec{s}_t and \vec{s}_{t+1} , respectively. What can we then say about $u(\vec{c}_t, \vec{c}_{t+1})$? We may drop the subscripts t and $t+1$, since we are dealing with a given time t throughout. We observe that $u(\vec{c}, \vec{c})$ must be strategically equivalent to $\vec{u}(\vec{c} | \vec{s})$ for decisions affecting \vec{c} only and that $u(\vec{c}, \vec{c})$ must be strategically equivalent to $\vec{u}(\vec{c} | \vec{s})$ for decisions affecting \vec{c} only. It follows that

$$u(\vec{c}, \vec{c}) = \vec{a}(\vec{c}) + \vec{b}(\vec{c})\vec{u}(\vec{c} | \vec{s}) = \vec{a}(\vec{c}) + \vec{b}(\vec{c})\vec{u}(\vec{c} | \vec{s}), \quad (11.4)$$

where the $a(\cdot)$ and $b(\cdot)$ functions are scalars. Now, we deduce from the right-hand side of (11.4) that \vec{u} can depend on the future only through \vec{a} , \vec{b} , and \vec{s} , so that u depends at most on \vec{a} , \vec{b} , \vec{s} , \vec{a} , \vec{b} , and \vec{s} . We can think of these as the six "features" of c that matter: three features of the past and three features of the future. Careful analysis, however, will reveal that at most four of these features can vary independently: \vec{s} and \vec{s} always affect our preferences, and any two of the other four may

¹ To prove this for $c_{t,t'}^0$, observe that \vec{u}_{t+1} depends on \vec{c}_t only through \vec{s}_t and that \vec{u}_t depends on \vec{c}_{t+1} only through \vec{s}_{t+1} , so that, if $c_{t,t'}^0$ minimizes $u(\vec{c}_t, c_{t,t'}, \vec{c}_{t+1})$ over all $c_{t,t'}$, then $c_{t,t'}^0$ will minimize \vec{u}_{t+1} for all pasts with the same \vec{s}_t as \vec{c}_t , and $c_{t,t'}^0$ will minimize \vec{u}_t for all futures with the same \vec{s}_{t+1} as \vec{c}_{t+1} . A similar argument holds for $c_{t,t'}^*$.

enter as independently varying functions into the utility structure. This analysis is carried out in the Appendix to this paper and is based on the following lemma.

LEMMA Let $\vec{a}(\vec{c})$ vary independently of $\vec{b}(\vec{c})$ and $\vec{s}(\vec{c})$, in the sense that for some \vec{c} there exists a \vec{c}' for which $\vec{a}(\vec{c}') \neq \vec{a}(\vec{c})$ but \vec{b} and \vec{s} are unchanged. Then \vec{b} depends only on \vec{c} through \vec{s} .

Proof The proof follows from (11.4). Evaluate (11.4) at \vec{c} and \vec{c}' and subtract the two to obtain

$$\vec{a}(\vec{c}) - \vec{a}(\vec{c}') = \vec{b}(\vec{c})[u(\vec{c}|\vec{s}) - u(\vec{c}'|\vec{s})] \text{ for all } \vec{c}. \quad (11.5)$$

Since the left-hand side of (11.5) does not depend on \vec{c} , and since the factor on the right in brackets depends on \vec{c} only through \vec{s} , it follows that \vec{b} can depend on \vec{c} only through \vec{s} .

From this lemma we conclude that the following three cases cover all possible consistent “structures” for \vec{a} and \vec{b} :

1. \vec{a} is independent of \vec{b} and \vec{s} , and $\vec{b} = \vec{b}(\vec{s})$.
2. \vec{a} is a function of \vec{b} and \vec{s} only, and \vec{b} can vary independently of \vec{s} .
3. \vec{a} is a function of \vec{b} and \vec{s} only, and $\vec{b} = \vec{b}(\vec{s})$.

Clearly, a similar lemma and trichotomy will hold when \vec{a} and \vec{b} are replaced by \vec{a} and \vec{b} , so that we have to examine a total of $3 \times 3 = 9$ subcases. These nine cases are examined in the Appendix, and it is shown there that only the four subcases deriving from cases 1 and 2 above matter – case 3 does not contribute a new and different structure. The resulting four structures are

$$u = \vec{a} + \vec{a} + f(\vec{s}, \vec{s}) \quad (11.6)$$

$$u = \vec{b} \vec{b} f(\vec{s}, \vec{s}) + \text{constant} \quad (11.7)$$

$$u = \vec{a} + \vec{b} f(\vec{s}, \vec{s}) \quad (11.8)$$

$$u = \vec{a} + \vec{b} f(\vec{s}, \vec{s}) \quad (11.9)$$

where \vec{a} and \vec{b} (\vec{a} and \vec{b}) denote functions of \vec{c} (\vec{c}) that may be independent, in the sense of the lemma, of each other and of \vec{s} (\vec{s}). Note that each of the four forms contains two “features” of the stream c in addition to \vec{s} and \vec{s} . In (11.6) and (11.7) past and future are treated symmetrically, with one feature devoted to each. Clearly, (11.6) is a generalization of the additive form, and (11.7) is a generalization of the multiplicative form. It is interesting to observe that the only utility dependence of past and future enters through \vec{s} and \vec{s} . By contrast, past and future are treated asymmetrically in (11.8) and (11.9), both features being assigned to one or the other. Thus (11.8) implies that an efficient forward descriptor \vec{s} that tells all one needs to know about the distant future to make decisions

about the near future is all one cares about when making decisions about the distant future.

The next question to explore is: What happens when one of the four forms (11.6)–(11.9) applies at *every* time t ? The general answer to this question is unknown, but there are a number of interesting structures that result from the symmetric cases (11.6) and (11.7). We begin by observing that if u satisfies (11.6), then $e^{\alpha u + \beta}$ satisfies (11.7), so we need consider solutions to (11.6) only. One such solution is of the form

$$u(c) = \sum_{t=1}^n a_t(c_t) + f\left(\sum_{t=1}^n z_t(c_t) + \bar{s}_0 + \bar{s}_{n+1}\right). \quad (11.10)$$

This satisfies (11.6) for $1 \leq t \leq n$, as we may see by identifying \bar{a} , \vec{a} , \bar{s} , and \vec{s} according to

$$\begin{aligned} \bar{a}_t &= \sum_{t'=1}^t a_{t'}(c_{t'}); \vec{a}_{t+1} = \sum_{t'=t+1}^n a_{t'}(c_{t'}) \\ \bar{s}_t &= \bar{s}_0 + \sum_{t'=1}^t z_{t'}(c_{t'}); \vec{s}_{t+1} = \sum_{t'=t+1}^n z_{t'}(c_{t'}) + \bar{s}_{n+1}. \end{aligned}$$

An especially simple form of u results if we choose $f(\cdot)$ in (11.10) to be an exponential function. In that case the single-period utility for period t will be a linear combination of $a_t(\cdot)$ and $z_t(\cdot)$, with weights that depend on the pattern of c in all other periods. Thus we could, for example, choose $a_t(\cdot)$ and $z_t(\cdot)$ to be two exponential utility functions with different risk aversion, e.g., $-e^{-\alpha c_t}$ and $-e^{-\zeta c_t}$, so that the utility for period t is the sum of two exponentials (Meyer and Pratt, 1968; Schlaifer, 1971), but with a risk-aversion function that changes from α to ζ over a range of c_t determined by all other components of c . Alternatively, we could choose $a_t(\cdot) = z_t(\cdot)$, in which case (11.10) becomes the special case of the multilinear form when only the pure sum and pure product term are present.

Equation (11.10) is not the only form of solution that satisfies (11.6) for every t . Another useful structure is given by

$$u(c) = \sum_{t=0}^n \sum_{t'=t+1}^{n+1} y_t(c_t) z_{t'}(c_{t'}), \quad (11.11a)$$

where for notational convenience we have introduced

$$y_0(\cdot) = \bar{s}_0, z_{n+1}(\cdot) = \bar{s}_{n+1}. \quad (11.11b)$$

The proper identification of \bar{a} , \vec{a} , \bar{s} , and \vec{s} can be made by rewriting (11.11a) as follows (arguments are dropped throughout):

$$\begin{aligned} u(c) &= (y_0 + y_1 + \dots + y_{t-1})(z_t + \dots + z_n + z_{n+1}) \\ &+ (y_0 + y_1 + \dots + y_{t-2})z_{t-1} + \dots + (y_0 + y_1)z_2 + y_0 z_1 \\ &+ y_t(z_{t+1} + \dots + z_n + z_{n+1}) + \dots + y_{n-1}(z_n + z_{n+1}) + y_n z_{n+1}. \end{aligned} \quad (11.12)$$

Let us introduce the state descriptors \vec{s}_{t-1} and \vec{s}_t according to

$$\vec{s}_{t-1} = y_0 + y_1 + \dots + y_{t-1}; \vec{s}_t = z_t + \dots + z_n + z_{n+1}, \quad (11.13)$$

so that the first line in (11.12) is the product $\vec{s}_{t-1} \vec{s}_t$. The second line of (11.12) depends only on the past, so we identify it as \vec{a}_{t-1} , and the third line is clearly \vec{a}_t since it depends only on the future.

A particularly interesting form of (11.11a) occurs when we choose

$$y_t(\cdot) = \beta^{-t} y(\cdot); z_t(\cdot) = \beta^t z(\cdot), \quad 0 \leq \beta \leq 1. \quad (11.14)$$

In this case \vec{s}_{t-1} and \vec{s}_t are obtained by discounting, with heavier weights given to time periods closer to t . In other words, the discounting is backward for \vec{s}_t and forward for \vec{s}_{t-1} , just as we would want. Also, the single-period utility for period t is of the form

$$\begin{aligned} u_t(c_t | c^t) &= (y_0 + \dots + y_{t-1})z_t + y_t(z_{t+1} + \dots + z_{n+1}) \\ &= \left[\sum_{i=1}^t \beta^i y(c_{t-i}) \right] z(c_t) + \left[\sum_{i=1}^{n+1-t} \beta^i z(c_{t+i}) \right] y(c_t), \end{aligned}$$

so that single-period utilities are a sum of $z(\cdot)$ and $y(\cdot)$ with weights depending on the past and the future, respectively. Thus we have found a way to reintroduce discounting, but for the state descriptors rather than to combine single-period utilities.

There is yet another special form to be derived from (11.11a). Earlier it was stated that if the u given by (11.11a) satisfies (11.6), $-e^{-\alpha u}$ will satisfy (11.7). Let us choose $y_t(\cdot) = \beta^{-t} w(\cdot)$ and $z_t = \beta^t w(\cdot)$, so that

$$u(c) = -\exp \left[-\alpha \sum_{t=1}^{n-1} \sum_{t'=t+1}^n \beta^{t'-t} w(c_t) w(c_{t'}) \right]. \quad (11.15)$$

The single-period utilities become

$$u_t(c_t | c^t) = -\exp -\alpha \left[\sum_{t'=t+1}^n \beta^{t'-t} w(c_{t'}) + \sum_{t'=1}^{t-1} \beta^{t-t'} w(c_{t'}) \right] w(c_t), \quad (11.16)$$

so that single-period utilities are of the form $u_t = -\exp [-\gamma_t w(c_t)]$ where γ_t depends on the past and the future. Now we recognize that if u_t is of this form, then the single-period risk-aversion function (see Pratt, 1964) is

$$u_t''/u_t' = -w''/w' + \gamma_t w',$$

and this shows how the past and the future influence, through γ_t , our risk aversion for the current period.

Equation (11.15) is a very useful form for further analytical work, especially if $w(\cdot)$ is chosen to be linear. It exhibits all the discounting, risk-aversion, and temporal-interdependence properties we may feel necessary and thus shows the richness of temporal preference modeling available to us through the use of efficient state descriptors.

11.A APPENDIX

In this appendix the implications of (11.4), reproduced here for convenience, are explored:

$$u(\vec{c}, \vec{c}) = \vec{a}(\vec{c}) + \vec{b}(\vec{c})\vec{u}(\vec{c} | \vec{s}) \quad (11.A1)$$

$$= \vec{a}(\vec{c}) + \vec{b}(\vec{c})\vec{u}(\vec{c} | \vec{s}) \quad (11.A2)$$

Following the reasoning outlined in section 11.3, we trichotomize the properties of forward and backward descriptors, depending on whether \vec{a} (\vec{a}) may vary independently of \vec{b} and \vec{s} (\vec{b} and \vec{s}). The resulting nine cases, which are mutually exclusive and jointly exhaustive, are shown in Table 11.A1. For each case, the way in which (11.A1) and (11.A2) specialize under the particular assumptions regarding \vec{a} , \vec{a} , \vec{b} , and \vec{b} is reported, and the resulting equations are marked (1) and (2), respectively. Each case implies a certain structure for $u(\vec{c}, \vec{c})$, which is also shown in the table. The arguments necessary to derive this structure from equations (1) and (2) are given below for six of the nine cases. The other three cases follow from symmetry arguments. It is also shown below that the resulting utility structure in each case satisfies the corresponding equations (1) and (2) – i.e., it is both necessary and sufficient.

The arguments are presented in detail for the first case, so as to explain the notation and general method. The other cases are dealt with more concisely, and reference to Table 11.A1 is necessary.

CASE I

We see from Table 11.A1 that (11.A1) and (11.A2) specialize to

$$u = \vec{a} + \vec{b}(\vec{s})\vec{u}(\vec{c} | \vec{s}) \quad (1)$$

$$= \vec{a} + \vec{b}(\vec{s})\vec{u}(\vec{c} | \vec{s}). \quad (2)$$

Here the notation \vec{a} (\vec{a}) without argument is meant to convey that \vec{a} (\vec{a}) can, through appropriate changes in \vec{c} (\vec{c}), be made to vary without varying \vec{b} (\vec{b}) or \vec{s} (\vec{s}). Similarly, the notation $\vec{b}(\vec{s})$ [$\vec{b}(\vec{s})$] conveys the fact that variations in \vec{c} (\vec{c}) influence \vec{b} (\vec{b}) only through their impact on \vec{s} (\vec{s}).

It follows from (1) that u can depend on \vec{c} only through \vec{a} and \vec{s} , and it follows similarly from (2) that u can depend on \vec{c} only through \vec{a} and \vec{s} , so we may, without loss of generality, write u as

$$u = \vec{a} + \vec{a} + f(\vec{s}, \vec{s}, \vec{a}, \vec{a}) \quad (11.A3)$$

where f is an arbitrary function.

Substitute (11.A3) in (1) and (2) to obtain

$$\vec{b}(\vec{s})\vec{u}(\vec{c} | \vec{s}) = \vec{a} + f(\vec{s}, \vec{s}, \vec{a}, \vec{a}) \quad (11.A4)$$

$$\vec{b}(\vec{s})\vec{u}(\vec{c} | \vec{s}) = \vec{a} + f(\vec{s}, \vec{s}, \vec{a}, \vec{a}). \quad (11.A5)$$

TABLE 11.A1

\vec{a} ind. (\vec{b}, \vec{s}) ; $\vec{b} = \vec{b}(\vec{s})$	$\vec{a} = \vec{a}(\vec{b}, \vec{s})$; $\vec{b} = \vec{b}(\vec{s})$	$\vec{a} = \vec{a}(\vec{b}, \vec{s})$; $\vec{b} = \vec{b}(\vec{s})$	$\vec{a} = \vec{a}(\vec{b}, \vec{s})$; $\vec{b} = \vec{b}(\vec{s})$
\vec{a} ind. (\vec{b}, \vec{s})	Case I $u = \vec{a} + \vec{b}(\vec{s})\vec{u}(\vec{c} \vec{s})$ (1) $= \vec{a} + \vec{b}(\vec{s})\vec{u}(\vec{c} \vec{s})$ (2) $\Rightarrow u = \vec{a} + \vec{a} + f(\vec{s}, \vec{s})$	Case II $u = \vec{a} + \vec{b} \vec{u}(\vec{c} \vec{s})$ (1) $= \vec{a}(\vec{s}) + \vec{b}(\vec{s})\vec{u}(\vec{c} \vec{s})$ (2) $\Rightarrow u = \vec{a} + \vec{b} f(\vec{s}, \vec{s})$	Case III $u = \vec{a} + \vec{b}(\vec{s})\vec{u}(\vec{c} \vec{s})$ (1) $= \vec{a}(\vec{s}) + \vec{b}(\vec{s})\vec{u}(\vec{c} \vec{s})$ (2) $\Rightarrow u = \vec{a} + f(\vec{s}, \vec{s})$
$\vec{a} = \vec{a}(\vec{b}, \vec{s})$ $\vec{b} \neq \vec{b}(\vec{s})$	Case IV By symmetry from Case II: $u = \vec{a} + \vec{b} f(\vec{s}, \vec{s})$	Case V $u = \vec{a}(\vec{b}, \vec{s}) + \vec{b} \vec{u}(\vec{c} \vec{s})$ (1) $= \vec{a}(\vec{b}, \vec{s}) + \vec{b} \vec{u}(\vec{c} \vec{s})$ (2) $\Rightarrow u = \vec{b} \vec{b} f(\vec{s}, \vec{s}) + \text{const.}$	Case VI $u = \vec{a}(\vec{s}) + \vec{b}(\vec{s})\vec{u}(\vec{c} \vec{s})$ (1) $= \vec{a}(\vec{b}, \vec{s}) + \vec{b} \vec{u}(\vec{c} \vec{s})$ (2) $\Rightarrow u = \vec{b} f(\vec{s}, \vec{s}) + \vec{a}(\vec{b}, \vec{s})$
$\vec{a} = \vec{a}(\vec{b}, \vec{s})$ $\vec{b} = \vec{b}(\vec{s})$	Case VII By symmetry from Case III: $u = \vec{a} + f(\vec{s}, \vec{s})$	Case VIII By symmetry from Case VI: $u = \vec{b} \vec{b} f(\vec{s}, \vec{s}) + \vec{a}(\vec{b}, \vec{s})$	Case IX $u = \vec{a}(\vec{s}) + \vec{b}(\vec{s})\vec{u}(\vec{c} \vec{s})$ (1) $= \vec{a}(\vec{s}) + \vec{b}(\vec{s})\vec{u}(\vec{c} \vec{s})$ (2) $\Rightarrow u = f(\vec{s}, \vec{s})$

Since the left-hand side of (11.A4) depends on \vec{c} only through \vec{s} , it follows that the right-hand side cannot depend on \vec{a} and \vec{s} , so f does not depend on \vec{a} . Similarly, it is argued from (11.A5) that f cannot depend on \vec{a} either, so f must be a function of \vec{s} and \vec{s} alone, hence the result

$$u = \vec{a} + \vec{a} + f(\vec{s}, \vec{s}). \quad (11.A6)$$

Finally, we must show that (11.A6) actually satisfies (1) and (2) – i.e., that (1) and (2) impose no further conditions on u beyond those already accounted for in deriving (11.A6). From (1), (2) and (11.46), we conclude that

$$\vec{u}(\vec{c} | \vec{s}) = \frac{\vec{a} + f(\vec{s}, \vec{s})}{\vec{b}(\vec{s})} \quad (11.A7)$$

and

$$\vec{u}(\vec{c} | \vec{s}) = \frac{\vec{a} + f(\vec{s}, \vec{s})}{\vec{b}(\vec{s})}. \quad (11.A8)$$

Equation (11.A7) is indeed dependent on \vec{c} only through \vec{s} , and (11.A8) depends on \vec{c} only through \vec{s} , so consistency is established.

CASE II

Equation (2) implies that u depends on \vec{c} only through \vec{s} . Hence we see from (1) that $\vec{u}(\vec{c} | \vec{s})$ can depend only on \vec{s} and \vec{s} . Call this function $f(\vec{s}, \vec{s})$, and the result follows. Equation (1) is automatically satisfied. Equation (2) implies that

$$\vec{u}(\vec{c} | \vec{s}) = \frac{\vec{a} + \vec{b} f(\vec{s}, \vec{s}) - \vec{a}(\vec{s})}{\vec{b}(\vec{s})},$$

which indeed depends on \vec{c} only through \vec{s} .

CASE III

Equation (2) implies that u depends on \vec{c} only through \vec{s} , so from (1) we reason that \vec{u} depends on \vec{c} only through \vec{s} ; hence we may set $\vec{b} \vec{u} = f(\vec{s}, \vec{s})$, which yields the indicated result. By analogy to case II, it then follows from (2) that

$$\vec{u}(\vec{c} | \vec{s}) = \frac{\vec{a} + f(\vec{s}, \vec{s}) - \vec{a}(\vec{s})}{\vec{b}(\vec{s})},$$

so we again have consistency.

CASE V

It follows from (1) and (2) that u depends only on \vec{b} , \vec{b} , \vec{s} , and \vec{s} , and that

$$-\vec{a}(\vec{b}, \vec{s}) + \vec{b} \vec{u}(\vec{c} | \vec{s}) = -\vec{a}(\vec{b}, \vec{s}) + \vec{b} \vec{u}(\vec{c} | \vec{s}). \quad (11.A9)$$

The left-hand side of (11.A9) is a linear function of \vec{b} , and the right-hand side is a linear function of \vec{b} , so that both sides must be multilinear in \vec{b} and \vec{b} ; that is, they must be equal to

$$\alpha_0 + \alpha_1 \vec{b} + \alpha_2 \vec{b} + \alpha_3 \vec{b} \vec{b}, \quad (11.A10)$$

where the α 's may depend on \vec{s} and \vec{s} but not on \vec{b} and \vec{b} . Comparison of like terms of (11.A10) and (11.A9) yields

$$-\vec{a}(\vec{b}, \vec{s}) = \alpha_0 + \alpha_2 \vec{b} \quad (11.A11)$$

$$\vec{u}(\vec{c} | \vec{s}) = \alpha_1 + \alpha_3 \vec{b} \quad (11.A12)$$

$$-\vec{a}(\vec{b}, \vec{s}) = \alpha_0 + \alpha_1 \vec{b} \quad (11.A13)$$

$$\vec{u}(\vec{c} | \vec{s}) = \alpha_2 + \alpha_3 \vec{b} \quad (11.A14)$$

Equation (11.A11) implies that α_0 cannot depend on \vec{s} , and (11.A13) implies that α_0 cannot depend on \vec{s} , so α_0 must be a constant. Similar further analysis of the four equations above reveals that α_1 is a function of \vec{s} but not of \vec{s} , that α_2 is a function of \vec{s} but not of \vec{s} , and that α_3 may be a function of \vec{s} and \vec{s} . Substitution of (11.A12) and (11.A13) in (1) therefore yields

$$u = -\alpha_0 + \vec{b} \vec{b} \alpha_3(\vec{s}, \vec{s}),$$

which is the desired result if α_3 is renamed f . Sufficiency may be proven by substituting (11.A11) and (11.A12) in (2) and deriving the same expression for u .

CASE VI

From (1) we conclude that u depends on \vec{c} only through \vec{s} ; hence from (2) it follows that $\vec{u} = f(\vec{s}, \vec{s})$, whence the result. That this result also satisfies (1) is seen by solving (1) for \vec{u} :

$$\vec{u}(\vec{c} | \vec{s}) = \frac{\vec{a}(\vec{b}, \vec{s}) + \vec{b} f(\vec{s}, \vec{s}) - \vec{a}(\vec{s})}{\vec{b}(\vec{s})},$$

which indeed depends on \vec{c} only through \vec{s} .

CASE IX

Equation (1) implies that u depends on \vec{c} only through \vec{s} ; equation (2) implies that u depends on \vec{c} only through \vec{s} , hence the result, which is automatically consistent with (1) and (2).

CONCLUSION

A review of the results in Table 11.A1 allows identification of the truly different structures that have been uncovered. It is clear that the four cases I, II, IV, and V are fundamentally distinct, whereas all others are special cases of these four: III is a subcase of II; VI a subcase of IV; IX a subcase of all four, and so on.

REFERENCES

- Meyer, R.F. 1970. On the relationship among the utility of assets, the utility of consumption, and investment strategy in an uncertain but time invariant world. In *OR 69: Proceedings of the Fifth International Conference on Operational Research* (J. Lawrence, ed.). Tavistock, London, pp. 627–648.
- Meyer, R.F., and J.W. Pratt. 1968. The consistent assessment and fairing of preference functions. *IEEE Systems Science and Cybernetics*, Vol. SSE4, pp. 270–278.
- Oksman, W. 1974. Markov decision processes with utility independent objective functions. Doctoral dissertation. Harvard University, Cambridge, Massachusetts.
- Pratt, J.W. 1964. Risk aversion in the small and in the large. *Econometrica*, Vol. 32, pp. 122–136.
- Richard, S.F. 1972. Optimal life insurance decisions for a rational economic man. Doctoral dissertation. Graduate School of Business Administration, Harvard University, Cambridge, Massachusetts.
- Schlaifer, R.O. 1971. *Computer Programs for Elementary Decision Analysis*. Division of Research, Graduate School of Business Administration, Harvard University, Cambridge, Massachusetts.

DISCUSSION

PESCHEL: In some cases it might be natural to demand the utility independence condition between the variables in a certain interval from all the variables of intervals that are some specified distance out from this interval. This seems to correspond to a special case of your results.

MEYER: Yes, because in that case you want the state descriptor s_t to depend on, say, consumption in the three preceding periods, but not on consumption four or more periods ago. We want to use as a state descriptor $s_t = (c_t, c_{t-1}, c_{t-2})$, which can be updated by just shifting components and moving the next one in. An example of a real problem where such assumptions seemed appropriate was worked out by David Bell (see Chapter 18). His results fit neatly into this theory.

KULIKOWSKY: Is there any assumption about forgoing some present consumption to obtain greater future consumption? In other words, you invest now and you get the benefit in the future. Do you have something like that here?

MEYER: No, because we are talking about the preferences. First you must assess the utility for the consumption streams. You must also consider the economic environment, which includes the production function and anything that determines the constraints the real world imposes. Then you ask an optimization question, which is how to act in that constrained environment. What choices should you make in order to maximize expected utility? There is nothing in this model about environmental constraints of any sort.

LARICHEV: How can you verify conditions such as those described in your paper?

MEYER: That's not easy. David Bell describes (Chapter 18) how he derived one such utility function in the case of the budworm situation. It required painstaking, careful questioning about what you would do in the way of decisions if

you had one past, what you would do if you had another past, if you had a third one, and so on. You try to infer from the responses such things as whether there are independence conditions, or whether there are state variables that you seem to be dependent on. In other words, you attempt to map out the preferences as people reveal them through answers to hypothetical questions.

You can do it only through hypothetical questions. But it is to be hoped that these hypothetical questions relate very strictly to problems of extreme urgency to the person you are talking to. It's quite different to ask a random individual rather than a statesman about inflation versus unemployment trade-offs, especially when that individual feels he has no impact on the trade-offs between inflation and unemployment. But when you are trying to get a decision maker to assess things that are very urgent to him, then I think these hypothetical questions are a lot more meaningful and the answers are a lot more trustworthy.

Part Two

Applications

12 Use of Multiattribute Utility Measurement for Social Decision Making¹

Ward Edwards

Decisions do, and should, depend on values and probabilities – both subjective quantities. Public decisions, even more than other kinds, also should depend on values and probabilities. These quantities should be public, not only in the sense of being publishable, but also in the sense that the values, and perhaps the probabilities, that lie behind the decision should depend on some kind of social consensus, or at least on some kind of aggregation of individual views, rather than on any single individual's views.

The problem of obtaining such aggregate numbers differs for values and probabilities. A strong case can be made that probabilities should be generated out of data and expertise whenever both are available. Unless you happen to have a pocket calculator handy, your opinion about whether the natural logarithm of 222 is 5.40258 is not nearly so good as mine; I just calculated it. Considerations of social justice, every man's right to his own opinions, and the like, while never utterly irrelevant even to probabilities, become less important as differences in expertise become more important. Therefore, this paper will ignore the many fascinating problems of combining or reconciling conflicting views about probabilities and will deal only with the problem of public values.

As is discussed in detail below, the point just made about probabilities applies to values as well. Some aspects of value, specifically the location of the objects to be evaluated on the relevant dimensions of value, are also often matters of objective information, expertise, or some mixture of both. Yet most of us would agree that

¹ Preparation of this paper was supported by the Advanced Research Projects Agency, Department of Defense, under Department of the Navy, ONR, Prime Contract with Decisions and Designs, Inc., Subcontract #P.O.75-030-0711 between Decisions and Designs, Inc., and the University of Southern California. Reproduction for any U.S. Government use is permitted. I am grateful to Drs. Peter C. Gardiner, Marcia Guttentag, Michael F. O'Connor, and Kurt Snapper for their permission to review at length work for which they were wholly or partly responsible and to Drs. Edith H. Grotberg and Ralph Keeney for their helpful comments.

individuals are entitled to disagree about values and to have those disagreements respected and taken into account in public decision making. How can this be done?

Arrow's (1951) famous impossibility theorem has been interpreted by some as offering an answer: it doesn't. I cannot bring myself to take that answer very seriously, though I believe the theorem. Public decisions are made every day, and they do respond to individual differences in values in a crudely aggregative fashion. In my view, Arrow's assumptions are not strong enough. For one thing, he worked with ordinal rather than cardinal utility; this paper takes cardinal utilities for granted. For another, he was unwilling to assume the interpersonal comparability of utilities. Yet, with or without axiomatic justification, we do in fact compare strengths of preference every day. That argument, carried to its extreme, would lead to the rather uninteresting idea of making social choices on the basis of the averaged utilities of the people affected. Although social choices are often made by mechanisms of this nature (e.g., by voting), they are not the subject of this paper.

The thrust of this paper is that a public value is a value assigned to an outcome by a public, usually by means of some public institution that does the evaluating. This amounts to treating "a public" as a sort of organism whose values can be elicited by some appropriate adaptation of the methods already in use to elicit individual values. From this point of view, the problem's interest lies in finding the appropriate adaptation of those methods — an adaptation that will take into account individual disagreements about values, individual differences in relevant expertise, existing social structures for making public decisions, and problems of feasibility.

The paper is structured around three examples. One is land use management, specifically, a study aimed at the decision problems of the California Coastal Commission. The decision-making body in this case is a regulatory agency exposed to a wide variety of social pressures. While the public exposure to organized pressures is explicit in this example, most of the issues that arise in this form of social decision making also arise, often in subtler and more muted forms, in other social decision contexts.

The second example is administrative decision making — specifically, the process that the Office of Child Development of the U.S. Department of Health, Education, and Welfare used in developing its research program for the 1974 fiscal year. It is the only one of the three examples in which the tools were used to make real decisions. In a way, administrative decisions are misleading. The presence of a senior administrator with official power to make the decisions suggests, incorrectly, that this administrator's values are being maximized by the decisions made. Seldom is the case so simple. For one thing, every boss has a boss, and everyone attempts to take the values of his superiors into account in his own decisions. Moreover, every competent boss has a staff whose views he respects and whose values he regards as relevant, often more relevant than his own. Finally, administrative agencies often serve specific public constituencies, in addition to serving some abstract and impersonal ideal of the public good. The fact that values differ from one staff

member to another and from one constituency to another makes the case of the administrative decision maker not greatly different from the case of the regulatory commission. By the time pressures from above and from below are taken into account, little room may be left for the administrator's own personal values.

The third example is more abstract; it concerns an attempt to develop a consensus among disagreeing water quality experts about a measure of the merits of various water sources for two purposes: the input, before treatment, to a public water supply, and an environment for fish and wildlife. The experts were all involved in public decisions about water, but each worked in a different jurisdiction, so there was no need for consensus as a basis for decision. Still, agreed-upon measures of water quality for these purposes would be very useful.

The ideas presented in this paper are closely related to, and grow out of, those contained in Edwards (1971), Edwards and Guttentag (1975), and Edwards *et al.* (1975). Conceptually, these discussions overlap. They are closely related to those presented by Bauer and Wegener (1975); we, too, are engaged in exploring the fusion of multiattribute utility measurement with differential equation modeling as a tool for social planning. While this paper, being primarily concerned with existing applications, does not discuss that fusion, it may be helpful to keep its possibility in mind as a reason for this discussion of approaches to conflicting social values.

The focus of this paper is on planning. I do not understand the differences among evaluations of plans, evaluations of ongoing projects, and evaluations of completed projects; all seem to me to be instances of the same kind of intellectual activity. Multiattribute utility measurement can and, I believe, should be applied to all three; the only difference is that in ongoing or completed projects there are more opportunities to replace judgmental estimates of locations on value dimensions with utility transforms on actual measurements — still subjective, but with firmer ground in evidence.

The fundamental idea is this. Arguments over public policy typically turn out to hinge on disagreements about values. Such disagreements are often about degree, not kind; developed and developing nations may agree on the virtues of both increased industrialization and decreased degradation of the environment, but they may differ about the relative importance of these goals. Normally, such disagreements are fought out in the context of specific decisions, over and over again, at enormous social cost each time another decision must be made. Multiattribute utility measurement can spell out explicitly what the values of each participant (decision maker, expert, pressure group, government, and so on) are and show how and how much they differ — and, in the process, it can frequently reduce the extent of such differences. The exploitation of this technology permits regulatory or administrative agencies and other public decision-making organizations to shift their attention from specific actions to the values these actions serve and to the decision-making mechanisms that implement these values. By explicitly negotiating about,

agreeing on, and (if appropriate) publicizing a set of values, a decision-making organization can, in effect, inform those affected by its decisions about its ground rules. This can often remove the uncertainty inherent in planning and can often eliminate the need for costly, time-consuming, case-by-case adversary or negotiating proceedings. Thus, explicit social policies can be defined and implemented with more efficiency and less ambiguity. Moreover, such policies can easily be changed in response to new circumstances of changing value systems, and information about such changes can be easily, efficiently, and explicitly disseminated, greatly easing the task of implementing policy change.

12.1 A TECHNIQUE FOR MULTIATTRIBUTE UTILITY MEASUREMENT

Edwards (1971) has proposed the following technique for multiattribute utility measurement based on extensive use of simple rating procedures. While it lacks the theoretical elegance of techniques proposed by, for example, Raiffa (1968, 1969) or Keeney (1972), it has the great advantage of being easily taught to and used by a busy decision maker or member of a decision-making staff or organization. Moreover, it requires no judgments of preference or indifference among hypothetical entities. My experience with elicitation procedures suggests that such hypothetical judgments are unreliable and unrepresentative of real preferences; worse, they bore untutored decision makers either into rejection of the whole process or into acceptance of answers suggested by the sequence of questions rather than answers that reflect their real values – or both.

The basic idea of multiattribute utility measurement is very familiar (see, for example, Raiffa, 1968). Every outcome of an action may have value on a number of different dimensions. The technique, in any of its numerous versions, is to discover those values, one dimension at a time, and then to aggregate them across dimensions using a suitable aggregation rule and weighting procedure. Probably the most widely used, and certainly the simplest, aggregation rule and weighting procedure consists of simply taking a weighted linear average; only that procedure will be discussed here. Theory, simulation computations, and experience all suggest that weighted linear averages yield extremely close approximations to very much more complicated nonlinear and interactive “true” utility functions, while remaining far easier to elicit and understand. (See, for example, Wilks, 1938; Dawes and Corrigan, 1974; and Einhorn and Hogarth, 1975.)

The technique consists of ten steps.

Step 1. Identify the person or organization whose utilities are to be maximized. If, as is often the case, several organizations have stakes and voices in the decision, they must all be identified. People who can speak for them must be identified and induced to cooperate.

Step 2. Identify the issue or issues (i.e., decisions) to which the utilities needed

are relevant. Depending on context and purpose, the same objects or acts may have many different values. In general, utility is a function of the evaluator, the entity being evaluated, and the purpose for which the evaluation is being made. The third element of that function is sometimes neglected.

Step 3. Identify the entities to be evaluated. Formally, they are outcomes of possible actions. In a sense, however, the distinction between an outcome and the opportunity for further action is usually fictitious. The value of a dollar is the value of whatever you choose to buy with it; the value of an education is the value of the things the educated person can do that he could not have done otherwise. Since it is always necessary to cut the decision tree somewhere – to stop considering outcomes as opportunities for further decisions and instead simply to treat them as outcomes with intrinsic values – the choice of what to call an outcome becomes largely one of convenience. In practice, it is often sufficient to treat an action itself as an outcome. This amounts to treating the action as having an inevitable outcome – that is, one assumes that uncertainty about outcomes is not involved in the evaluation of that action. Paradoxically, this is often a good technique when the outcome is utterly uncertain, so uncertain that it is impractical or not worthwhile to explore all its possible consequences in detail and assign probabilities to each.

When uncertainty is explicitly taken into account in social decision making, the tool of choice for doing so is often a set of scenarios, each with a probability. A scenario is simply a hypothetical future, organized around the stakes in the decision at hand and taking into account the effect of various exogenous factors on the value of these stakes. While there has been considerable sophisticated experience in the combined use of scenarios and multiattribute utilities, no reports on this experience have yet been published.

Step 4. Identify the relevant dimensions of value for evaluation of the entities. As Raiffa (1969) has noted, goals are ordinarily hierarchical. It is often practical and useful to ignore their hierarchical structures, however, and instead to specify a simple list of goals that seem important for the purpose at hand.

It is important not to be too expansive at this stage. The number of relevant dimensions of value should be modest, for reasons that will become apparent shortly. The number of dimensions can be limited by restating and combining goals, or by moving upward in a goal hierarchy. Even more important, it can be limited by simply omitting the less important ones. There is no requirement that the list evolved in this step be complete, and there is much reason to hope that it will not be.

Step 5. Rank the dimensions in order of importance. This ranking, like Step 4, can be performed either by an individual or by representatives of conflicting values acting separately or by those representatives acting as a group. I prefer to try group processes first, so that the various arguments can be expressed openly, thus giving the participants a common information base, and then to get separate judgments from each individual. The separate judgments will differ, of course, both here and in the following step.

Step 6. Rate dimensions in importance-preserving ratios. To do this, start by assigning the least important dimension an importance of 10. (We use 10 rather than 1 to permit subsequent judgments to be finely graded and nevertheless expressed in integers.) Now consider the next-least-important dimension. How much more important (if at all) is it than the least important? Assign it a number that reflects that ratio. Continue on up the list, checking each set of implied ratios as each new judgment is made. Thus, if a dimension is assigned a weight of 20, while another is assigned a weight of 80, it means that the 20 dimension is one-fourth as important as the 80 dimension. By the time you reach the most important dimensions, there will be many checks to perform; typically, respondents will want to revise previous judgments to make them consistent with later ones; this is acceptable. Once again, individual differences are likely to arise.

Step 7. Sum the importance weights, divide each by the sum, and multiply by 100. This is a purely computational step that converts importance weights into numbers that, mathematically, are rather like probabilities. The choice of a 0-to-100 scale is, of course, completely arbitrary.

At this step, the folly of including too many dimensions at Step 4 becomes glaringly apparent. If 100 points are to be distributed over a set of dimensions and some dimensions are very much more important than others, then the less important dimensions will have nontrivial weights only if there are not too many of them. As a rule of thumb, eight dimensions is enough, and fifteen is too many. At Step 4 respondents should be discouraged from being too finely analytical; rather gross dimensions will be appropriate. Moreover, the list of dimensions may be revised later, and that revision, if it occurs, will typically consist of increasing rather than decreasing the number of dimensions.

Step 8. Measure the location of each entity being evaluated on each dimension. The word "measure" is used rather loosely here. There are three classes of dimensions: purely subjective, partly subjective, and purely objective. The purely subjective dimensions are perhaps the easiest; an appropriate expert is simply asked to estimate the position of that entity on that dimension on a 0-to-100 scale, where 0 is defined as the minimum plausible value and 100 is defined as the maximum plausible value. Note "minimum and maximum plausible" rather than "minimum and maximum possible." The minimum plausible value often is not total absence of the dimension.

A partly subjective dimension is one in which the units of measurement are objective but the locations of the entities must be subjectively estimated.

A purely objective dimension is one that can be measured nonjudgmentally, in objective units, before the decision. For partly or purely objective dimensions, it is necessary that the estimators provide not only values for each entity to be evaluated but also minimum and maximum plausible values, in the natural units of each dimension.

At this point we can identify a difference of opinion among users of multi-attribute utility measurement. Some (for example, Edwards, 1971) are content to

draw a straight line connecting maximum plausible with minimum plausible values and then to use this line as the source of transformed location measures. Others, such as Raiffa (1968), advocate the development of dimension-by-dimension utility curves. Of the various ways of obtaining such curves, the easiest is simply to ask the respondent to draw graphs. The X axis of each such graph represents the plausible range of performance values for the attribute under consideration. The Y axis represents the ranges of values or desirabilities or utilities associated with the corresponding X values.

Strong reasons argue for the straight-line procedure whenever the underlying dimension is conditionally monotonic (that is, either more is better than less or else less is better than more throughout the plausible range of the dimension, regardless of locations on the other dimensions). Essentially, these reasons are that such straight lines will produce close approximations to the true value functions after aggregation over dimensions (correlations in excess of .99 are typical), and, of course, elicitation effort is much reduced. Still, respondents are sometimes concerned about the nonlinearity of their preferences and may prefer to use the more complicated procedure. Additionally, preferences may not be monotone. Partly for these reasons, two of the three studies reported in this paper used nonlinear value curves, though they avoided the elaborate techniques dependent on hypothetical indifference judgments that have often been proposed in order to obtain such curves.

A common objection to linear single-dimension value curves is that they ignore the economic law of diminishing returns. If you prefer meat to drink *and* regard meat as more important than drink and your utility function is linear with quantity of meat, you will keep on buying and perhaps consuming meat until you die of thirst. The objection is valid in some contexts, especially those in which the dimensions of value are separable, as they are in a commodity bundle, or those in which the set of available options is so rich that the dimensions might as well be separable. For contexts like those used as examples in this paper, the objection is irrelevant; linear single-dimension value curves could have been used whenever conditional monotonicity applies in all three examples. The option of reducing less important dimensions to near-zero values did not exist.

In what sense, if any, are rescaled location measures comparable from one scale to another? The question cannot be considered separately from the question of what "importance," as it was judged at Step 6, means. Formally, judgments at Step 6 should be designed so that when the output of Step 7 is multiplied by the output of Step 8, equal numerical distances between these products correspond to equal changes in desirability. Careful instruction is usually needed to communicate this concept to respondents.

Step 9. Calculate utilities for entities. The equation is

$$U_i = \sum_j w_j u_{ij},$$

where $\sum_j w_j = 100$, U_i is the aggregate utility for the i th entity, w_j is the normalized

importance weight of the j th dimension of value, and u_{ij} is the rescaled position of the i th entity on the j th dimension. Thus, w_j is the output of Step 7 and u_{ij} is the output of Step 8. The equation, of course, is nothing more than the formula for a weighted average.

Step 10. Decide. If a single act is to be chosen, the rule is simple: maximize U_i . If a subset of i is to be chosen, then the subset for which $\Sigma_i U_i$ is maximal is best.

A special case arises when one of the dimensions, such as cost, is subject to an upper bound — that is, when there is a budget constraint. In that case, the constrained dimension should be ignored in Steps 4 through 10. The ratios U_i/C_i , where C_i is the cost of the i th entity, should be chosen in decreasing order of that ratio until the budget constraint is used up. (More complicated arithmetic is needed if programs are interdependent or if this rule does not come very close to completely exhausting the budget constraint.) This is the only case in which the benefit-to-cost ratio is the appropriate figure on which to base a decision. In the absence of budget constraints, cost is just another dimension of value, entering into U_i with a minus sign, like other unattractive dimensions. In the general case, it is the benefit-minus-cost difference, not the benefit-over-cost ratio, that should usually control action.

An important caveat needs to be added concerning benefit-to-cost ratios. Such ratios assume that both benefits and costs are measured on a ratio scale — that is, a scale with a true zero point and ratio properties; however, the concepts of both zero benefit and zero cost are somewhat imprecise on close analysis. A not-too-bad solution to the problem is to assume that you know what zero cost means, and then attempt to find the zero point on the aggregate benefit scale. If that scale is reasonably densely populated with candidate programs, an approach to locating that zero point is to ask the decision maker, “Would you undertake this program if it had the same benefits it has now, but had zero cost?” If the answer is yes, the program is above the zero point on the benefit scale; if the answer is no, it is below the zero point.

The multiattribute utility approach can easily be adapted to cases in which there are minimum or maximum acceptable values on a given dimension of value by simply excluding alternatives that lead to outcomes that transgress these limits.

Because its emphasis is on simplicity and on rating rather than on more complicated elicitation methods, I call the above technique a Simple Multiattribute Rating Technique (SMART). I leave the critics the task of extending the acronym to show that its users are SMART-alecs.¹

FLEXIBILITIES OF THE METHOD

Practically every technical step in the preceding list has alternatives. For example, Keeney (1974) has proposed use of a multiplicative rather than an additive aggregation rule. Certain applications have combined multiplication and addition. The methods suggested above for obtaining location measures and importance weights

¹ A reviewer suggests “Always Linearizing Every Conceivable Scale.”

have alternatives; the most common is the direct assignment of importance weights on a 0-to-100 scale. (I consider this procedure inferior to the one described above, but I doubt that it makes much practical difference in most cases.)

INDEPENDENT PROPERTIES

Either the additive or the multiplicative version of the aggregation rule assumes value independence. Roughly, value independence means that the extent of your preference for location a_2 over location a_1 of dimension A is unaffected by the position of the entity being evaluated on dimensions B, C, D , and so on. Value independence is a strong assumption, not easily satisfied. Fortunately, in the presence of even modest amounts of measurement error, quite substantial deviations from value independence will make little difference to the ultimate number U_i , and even less to the rank ordering of the U_i values. [For discussions of the robustness of linear models, on which this assertion depends, see Dawes and Corrigan (1974) and Einhorn and Hogarth (1975).] A frequently satisfied condition that makes the assumption of value independence very unlikely to cause trouble is conditional monotonicity; that is, the additive approximation will almost always work well if, for each dimension, either more is preferable to less or less is preferable to more throughout the range of the dimension that is involved in the evaluation for all available values of the other dimensions. When the assumption of value independence is unacceptable even as an approximation, much more complicated models and elicitation procedures that take value dependence into account are available (Keeney and Raiffa, 1976).

A trickier issue than value independence is what might be called environmental independence. The traffic congestion caused by a coastal development is extremely likely to be positively correlated with the number of people served by the development. Yet these two dimensions may be value-independent; the correlation simply means that programs that cause little traffic congestion and serve many people are unlikely to present themselves for evaluation.

Violations of environmental independence can lead to double counting. If two value dimensions are perfectly environmentally correlated, only one need be included in the evaluation process. If both are included, care must be taken to make sure that the aggregate importance weight given to both together properly captures their joint importance. For example, if number of people served and traffic congestion were perfectly environmentally correlated and measured on the same scale after rescaling, if they had equal weights, and if one entered with positive and the other with negative sign into the aggregation, the implication would be that they exactly neutralized each other, so that any feasible combination of these two variables would be equivalent in value to any other feasible combination. The decision maker is unlikely to feel that way, but he may have trouble adjusting his importance weights to reflect his true feelings. His life could be simplified if he redefined the two dimensions into one — e.g., number of people served, taking into consideration all that implies with respect to traffic.

The problem is complicated if the environmental correlation is high but not perfect, but the solution remains the same: try, whenever possible, to define or redefine value dimensions in order to keep environmental correlations among them low. When this cannot be done, check on the implications of importance weights and location measures assigned to environmentally correlated dimensions to make sure that their aggregate weight properly reflects their aggregate importance. The situation is similar, though transparent examples are harder to construct, when the sign of the environmental correlation and the signs with which the dimensions enter into the aggregate utility function are such that double counting would over-emphasize rather than underemphasize the importance of the aggregate of the two dimensions.

A final technical point should be made about environmental correlations.¹ In general, if you must choose one entity from all the possibilities, the correlation between the dimensions will be large and negative. In the technical language of decision theory, the point is simply that the undominated set of acts (i.e., the contending entities) must lie on the convex boundary and so are necessarily negatively correlated with one another. This point becomes much less significant when one is selecting a number of entities rather than just one, since the selection of each entity removes it from the choice set, redraws the convex boundary of remaining entities, and probably thus reduces the negative correlation.

Unfortunately, the higher the negative environmental correlation among value dimensions, the less satisfactory the use of the value independence assumption becomes as an approximation when value correlations are actually present. At present, I know of no detailed mathematical or simulation study of the effect of size of the environmental correlation on acceptability of the value-independence approximation. This question is likely to receive detailed examination in the next few years.

12.2 EXAMPLE 1: LAND USE REGULATION²

12.2.1 THE CALIFORNIA COASTAL COMMISSION

Before 1972, two hundred separate bodies — city, county, state, and federal governments, agencies, and commissions — regulated the California coast. The citizens of California, in reviewing the performances of these two hundred bodies, were apparently dissatisfied, and, in a voter-sponsored initiative placed on the ballot during the general election of 1972 they approved legislation placing coastal zone planning and management under one state commission and six regional commissions. In passing the Coastal Zone Conservation Act with 55 per cent of the vote, the voters invested decision makers with ultimate authority (to be overruled only

¹ I am grateful to David Seaver, who first called the issue discussed in the following paragraphs to my attention.

² This example, based on Dr. Peter Gardiner's Ph.D. thesis (1974), has also been discussed at length in Gardiner and Edwards (1975).

through appeal to the courts) to preserve, protect, restore, and enhance the environment and ecology of the state's coastal zone.

The coastal zone is defined in the Act as the area between the seaward limits of state jurisdiction and 1,000 yards (~910 m) landward from the mean high tide line. Any plan for development within the coastal zone must be approved by the appropriate regional commission before it can be implemented. Disapprovals can be appealed to the state commission and then to the courts if necessary. (Development permits are similar to other types of building permits and authorize only the specific activities named.)

The South Coast Regional Commission (Region V), comprising Los Angeles and Orange counties, is one of the six regional commissions. Los Angeles County is heavily urbanized and in 1970 contained 35 per cent of the state's population and 41 per cent of the state's coastal county population. Los Angeles County includes the coastal cities of Long Beach, Redondo Beach, Hermosa Beach, Manhattan Beach, Los Angeles (Venice and the harbor area), and Santa Monica and unincorporated county areas such as Marina del Rey. These cities and areas all contain portions of the coastal zone that are under the control of the Region V Commission. Approximately \$1 billion worth of development was authorized in the first year of the commission's activities, and over 1,800 permits were acted upon. At times there has been a backlog of as many as 600 permit requests awaiting action. The evaluation and decision-making tasks that confront the Region V Commission members are important, far-reaching, difficult, and controversial.

Although the Act specifies that certain attributes should be considered in making evaluations, it fails to specify just how they are to enter into the evaluation process. Nor does the Act specify how the commissioners are to balance the conflicting interests affected by their decisions. In effect, the Act implies that individual commissioners assigned to the commission will represent the interests of all affected parties with respect to the coastal zone in Region V. How this is to be accomplished is left unspecified. In practice, attempts to include the preferences and value judgments of interested groups and individuals occur when the commission holds public advocacy hearings on permit requests. Under these procedures, opposing interest groups express their values and viewpoints as conclusions – often based on inconsistent sets of asserted facts or on no facts at all – in the form of verbal and written presentations at the open hearings.

Fourteen individuals involved in coastal zone planning and decision making agreed to participate in the study reported here. They included two of the current coastal commissioners for Region V, a number of active conservationists, and one major coastal zone developer. The purpose of this study was to test the consequences of using multiattribute utility measurement processes by having people with differing views who participate in or are close to the regulatory process make both individual and group evaluations of various proposals for development in a section of the California coastal zone. Evaluations were made both intuitively and by constructing multiattribute utility measurement models.

To provide a common basis for making evaluations, a sample of 15 hypothetical but realistic permit requests for development was invented. The types of permits were limited to those for development of single-family, duplex, triplex, or multi-family dwellings (owner-occupied or for renting). Dwelling unit development (leading to increased population density) is a major area of debate in current coastal zone decision making. Most permit applications submitted to the Region V Commission so far fall into this class. Moreover, permits granted in this class will probably generate further permit requests. Housing development tends to bring about the need for other development in the coastal zone – public works, recreation, transportation, and so on. The permit applications provided eight items of information about the proposed development that formed the information base on which subjects were asked to make their evaluations. These eight items were abstracted from staff reports submitted to the Region V coastal commissioners as a basis for their evaluations and decisions on current permit applications. The commissioners' staff reports do include some additional information (the name of the applicant, for example), but the following items are crucial to an evaluation:

1. *Size of development.* The number of square feet of the coastal zone taken up by the development.
2. *Distance from the mean high tide line.* The distance between the nearest edge of the development and the mean high tide line, measured in feet.
3. *Density of the proposed development.* The number of dwelling units per acre for the development.
4. *On-site parking facilities.* The percentage of cars brought in by the development for which parking space is provided as part of the development on-site.
5. *Building height.* The height of the development in feet (17.5 feet per story).
6. *Unit rental.* The dollar rental per month (on the average) for the development. If the development is owner-occupied and no rent is paid, an equivalent to rent is computed by taking the normal monthly mortgage payment.
7. *Conformity with land use in the vicinity.* The density, measured on a five-point scale from "much less dense" to "much more dense," of the development relative to the average density of adjacent residential lots.
8. *Esthetics of the development.* A rating on a scale from "poor" to "excellent."

Each of the invented permit applications was constructed to report a level of performance for each item. They were as realistic as possible and represented a wide variety of likely permits.

Each subject answered seven questionnaires; in general, 5 days was allowed for each questionnaire. In responding to the questionnaires, each subject (a) categorized him/herself on an 11-point continuum that ranged from very conservationist-oriented to very development-oriented, (b) evaluated intuitively (holistically) 15 sample development permit requests by rating their overall merit on a 0-to-100-point scale, (c) followed the steps of multiattribute utility measurement outlined previously and in so doing constructed individual and group value models, and

TABLE 12.1 Group Product Moment Correlations

Group	Test-Retest	Test	Retest
	Holistic Evaluations (Reliability)	Holistic-SMART Evaluations	Holistic-SMART Evaluations
1	0.949	0.944	0.917
2	0.867	0.665	0.873

(d) reevaluated the same 15 sample permit requests intuitively a second time.¹ Subjects were not told that the second batch of permits was a repetition of the first.

The location of the proposed developments was Venice, which is part of the city of Los Angeles between Santa Monica and Marina del Rey. Venice has a diverse population and has been called a microcosm (Torgerson, 1973); in many ways, it presents in one small area instances of all the most controversial issues associated with coastal zone decision making.

After completing the initial questionnaire, in which they categorized themselves according to their views about coastal zone development, the 14 individuals were divided into two groups. Group 1 comprised the eight more conservation-minded subjects, and Group 2 was composed of the other six subjects, whose views, by self-report, range from moderately to strongly prodevelopment.

In both the intuitive evaluation and multiattribute utility measurement tasks the subjects reported no major difficulty in completing the questionnaires. An example of one participant's value curves and importance weights is shown in Figure 12.1. The abscissae represent the natural dimension ranges and the ordinates represent value ranging from 0 to 100 points. Although the value curves shown are all monotone and could therefore be linearly approximated, as indicated earlier, 11 of the 14 subjects produced at least one nonmonotone value curve. Accordingly, this study used the actual value curves for each subject rather than the linear approximation.

To develop group intuitive ratings and group value models, each individual in a group was given, through feedback, the opportunity of seeing his group's initial responses on a given task (intuitive ratings, importance weights, and the like) and of revising his own judgments. These data were fed back in the form of group means. Averaging individual responses to form group responses produced the results reported in Table 12.1, which shows in the second column test-retest holistic

¹The evaluation and decision making in this study are assumed to be riskless. Decisions involving permit requests, by the nature of the permits themselves, suggest that the consequences of approval or disapproval are known with certainty. The developer states on his permit what he intends to do if the permit is approved and is thereby constrained if approval is granted. If the request is disapproved, there will be no development – unless the present or subsequent owner of the land presents a new or revised request. Revision of permit requests to meet commission objectives often occurs, both before and after the original hearing. In that sense, the commission's decisions are risky – but this possibility was omitted from the present study.

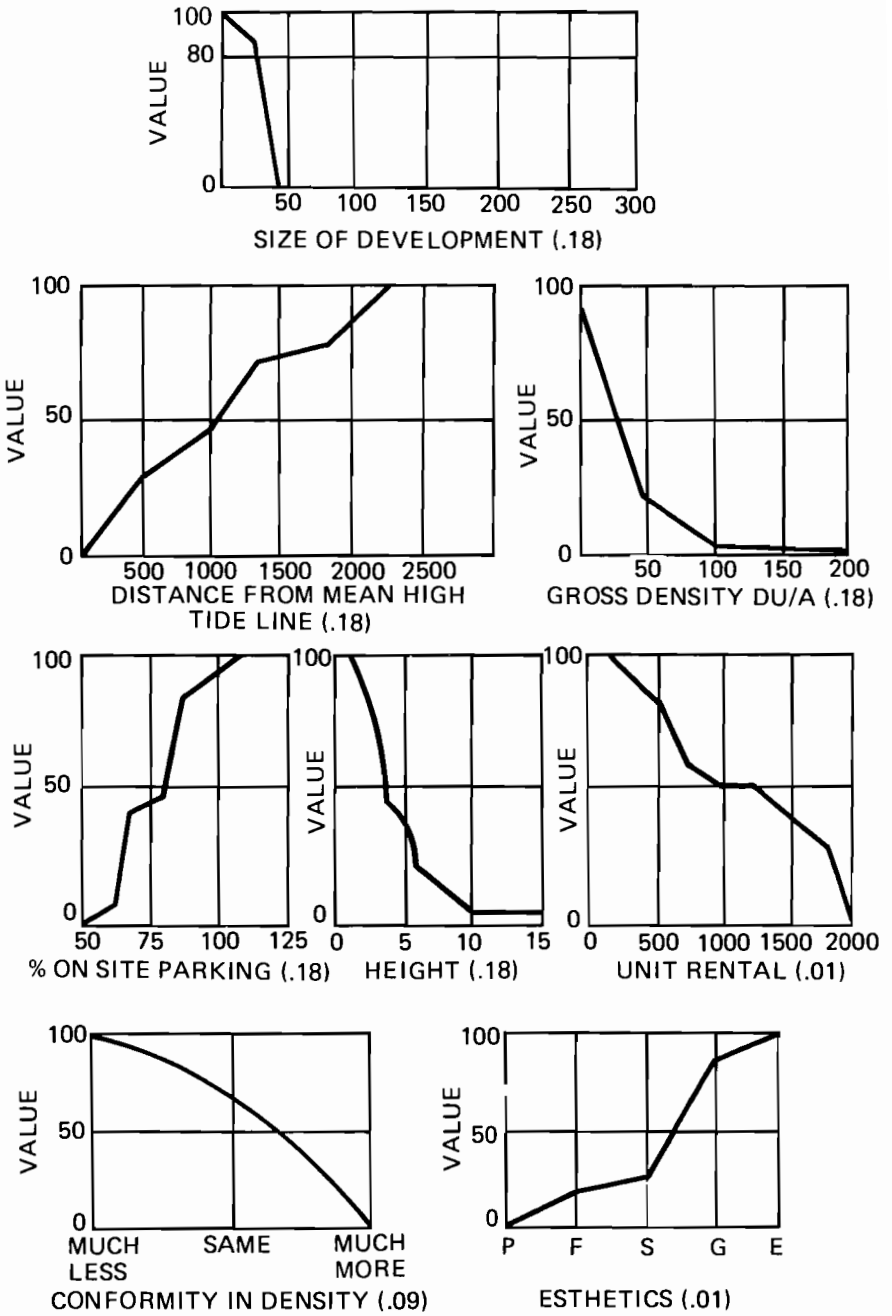

FIGURE 12.1 Value curves and importance weights for permit request dimensions. Importance weights are in parentheses.

evaluations of the 15 sample permits. These correlations are computed by taking the mean group ratings for each permit on the initial (test) intuitive evaluation and the second (retest) intuitive evaluation. The test holistic—SMART evaluation correlations are computed by comparing a group value model's ratings of the 15 sample permits with the group's initial intuitive evaluations. The group value model is found by computing the mean importance weights and mean value curves for the group and then evaluating each permit using the group's value model. The retest holistic—SMART evaluation correlations are similar except that the second intuitive evaluation is used.

As can be seen from Table 12.1, each group's value model, constructed according to the procedures of multiattribute utility measurement, has apparently "captured" the holistic evaluations of the group reasonably well. The interesting question is then "What is the effect of using a group's value models versus that of using a group's intuitive evaluation?"

To answer this question, a two-way analysis of variance of permit values was conducted. The independent variables were groups and permit requests. These results indicate that the two groups initially (i.e., by holistic intuitive evaluations) held differing viewpoints (i.e., were drawn from differing populations) although the differences were not dramatic. Substantial percentages of variance were accounted for both by group main effects and by permit—group interactions for the first-test holistic evaluations. Results for the retest were similar. Both findings indicate differing viewpoints between the two groups. The main effect could be caused, however, by a constant evaluation bias alone. The key indication of differing viewpoints is the interaction term. The use of each group's value model evaluations instead of their intuitive evaluations causes the percentage of variance accounted for by the interaction to drop from 12 percent to 2 percent. Figure 12.2 shows this difference dramatically. The multiattribute utility technique has turned modest disagreement into substantial agreement.

Why? Here is a plausible answer. When making holistic evaluations, people with strongly held points of view tend to concentrate on those aspects of the entities being evaluated that most strongly engage their biases. The multiattribute procedure does not permit this; it separates judgment of the importance of a dimension from judgment of where a particular entity falls on that dimension. These applications varied on eight dimensions relevant to the environmentalists-versus-builders arguments. While these two views may be reflected in different opinions about how good a particular level of performance on some dimensions may be, evaluation on other dimensions will be more or less independent of viewpoint. Agreement about those other dimensions tends to reduce the impact of disagreement on controversial dimensions. That is, multiattribute utility measurement procedures do not allow any one or two dimensions to become so salient that they emphasize existing sources of conflict and disagreement. Multiattribute utility measurement cannot and should not eliminate all disagreement, however; such conflicts are genuine, and any value measurement procedure should respect and so reflect them. Still, in spite of disagreement, social decisions must be made. How?

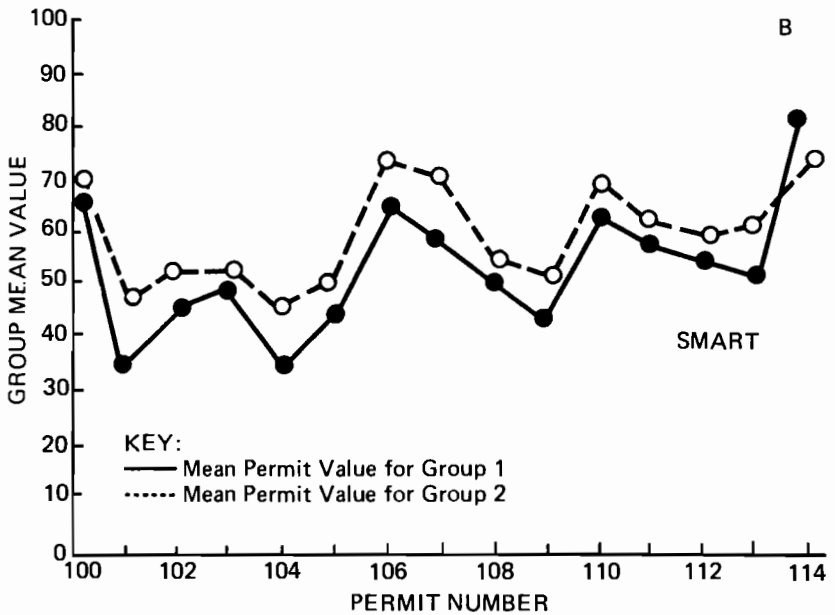
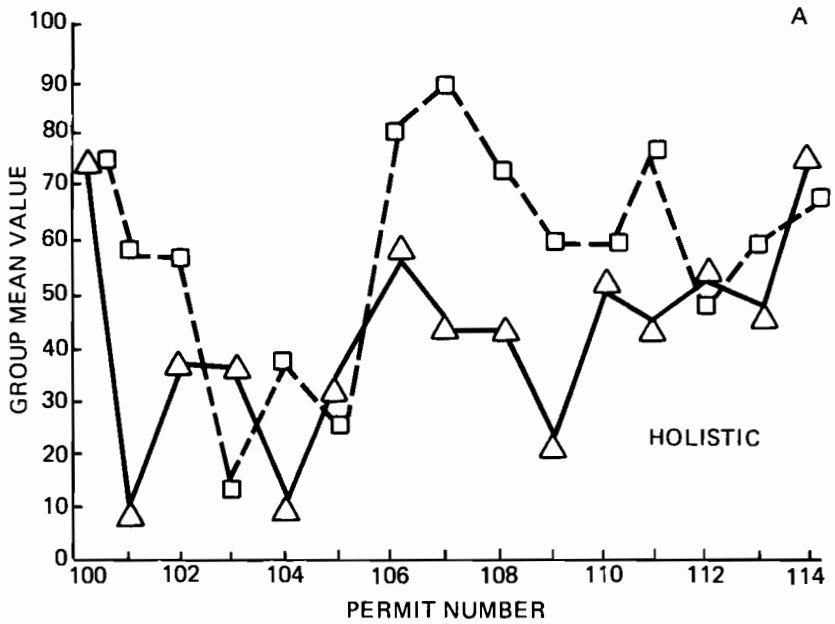

FIGURE 12.2 SMART-fostered agreement. *A*, mean value for each group as a function of permit number based on holistic judgments of value. *B*, mean value for each group as a function of permit number based on each judge's SMART judgments. Solid line: mean permit value for Group 1. Dashed line: mean permit value for Group 2.

I distinguish between two kinds of disagreements. Disagreements at Step 8 seem to me to be essentially like disagreements among different thermometers measuring the same temperature. If they are not too large, one has little compunction about taking an average. If they are large, then one is likely to suspect that some of the thermometers are not working properly and to discard their readings. In general, I think that judgmentally determined location measures should reflect expertise, and I would expect different value dimensions typically to require different kinds of expertise and therefore different experts. In some practical contexts, one can avoid the problem of disagreement at Step 8 entirely by the simple expedient of asking only the best available expert for each dimension to make judgments about that dimension.

Disagreements at Steps 5 and 6 are another matter. These seem to me to be the essence of conflicting values, and they should be given as much respect as possible. For that reason, the judges who perform Steps 5 and 6 should be either the decision maker(s) or carefully chosen representatives of the decision maker. Considerable discussion, persuasion, and information exchange should be used in an attempt to reduce the disagreements as much as possible. At the least, this process offers a clear definition of the rules of debate and an orderly way to proceed from information and data to values and, finally, decisions.

Even this process will seldom dispel disagreements entirely, however. The next two examples will suggest ways to proceed further.

12.2.2 A PUBLIC TECHNOLOGY FOR LAND USE MANAGEMENT

I conclude this example with a rather visionary discussion of how agencies responsible for land use management could carry out their responsibilities by fully exploiting SMART or some similar value measurement technique.

The statutes would define, at least to some degree, the appropriate dimensions of value, as they do now. They might, but probably should not, specify limits on the importance weights attached to these dimensions. They might, and perhaps should, specify boundaries beyond which no value could go in the undesirable dimension.

The main functions of the regulatory agency would be four: to specify measurement methods for each value dimension (with utility functions or other methods for making the necessary transformations at Step 8); to specify importance weights; to define one or more bounds on acceptable levels of aggregated utility, and perhaps also to define lower bounds not specified by statute on particular dimensions; and to hear appeals.

The regulatory agency could afford to spend enormous amounts of time and effort on its first two functions, specification of measurement methods and of importance weights. Value considerations, political considerations, views of competing constituencies and advocates, the arts of political maneuvering and compromise — all would come into play. Public hearings would be held, with elaborate and extensive debate and full airing of all relevant issues and points of view.

The regulatory agency would have further responsibilities for dealing with measurement methods for wholly or partly subjective value dimensions. Since such measurements must be judgments, the regulatory agency must make sure that the judgments are impartial and fair. This could be done by having staff members make them, or by offering the planner a list of agency-approved impartial experts, or by mediating among or selecting from the conflicting views of experts chosen by those with stakes in the decision, or by some combination of these methods. I consider the first two of these approaches to be most desirable, but recognize that the third or fourth may be inevitable.

The reason the costs of prolonged and intensive study of measurement methods and of importance weights could be borne is that they would recur infrequently. Once measurement methods and importance weights had been agreed on, most case-by-case decisions would be automatically made by means of them. Only if political and social circumstances or technology changed would reconsideration of the agreed-on measurement methods and importance weights be necessary, and even such reconsiderations would be likely to be partial rather than complete. They would, of course, occur; times do change, public tastes and values change, and technologies change. Those seeking appropriate elective offices could campaign for such changes – an election platform consisting in part of a list of numerical importance weights would be a refreshing novelty!

The decision rules would, of course, be public knowledge. That fact probably would be the most cost-saving aspect of this whole approach. Would-be developers and builders would not waste their time and money preparing plans that they could easily calculate to be unacceptable. Instead, they would prepare acceptable plans from the outset. Once a plan had been prepared and submitted to the regulatory agency, evaluation would consist of little more than a check that the planner's measurements and arithmetic had been done correctly. Delay from submission to approval need be no more than a few days.

Changes in the decision rules can be and should be as explicit as the rules themselves. Such explicitness would permit both regulators and those regulated to know exactly what current regulatory policies are and, if they have changed, how and how much. Such knowledge would greatly facilitate both enlightened citizen participation in deciding on policy changes and swift, precise adaptation of those regulated to such changes once they have taken effect.

In short, multiattribute utility measurement allows value conflicts bearing on social decisions to be fought out and resolved at the level of decision rules, rather than at the level of individual decisions. Such decision rules, once specified, define regulatory policy, removing nearly all ambiguity, without impairing society's freedom to modify policies in response to changing conditions. Possible savings in financial and social costs, delay, frustration, and so on are incalculable, but cost reduction in dollars alone could be 90 percent or more.

Resolution of value conflicts at the level of decision rules rather than at the level of individual decisions may have the potential of revolutionary impact in land use

management and in many other public decision contexts as well. Any new idea is bound to be full of unexpected consequences, booby traps, and surprises. For a while, therefore, the wise innovator would want to run old and new systems in parallel, compare performance of the two, and build up experience with the new system. A good mechanism might be to define an upper and a lower bound, with automatic acceptance above the upper bound, automatic rejection below the lower one, and hearings in between. This would provide a convenient administrative device for operation of such parallel procedures. Initially, the upper bound could be very high and the lower bound very low so that most cases would fall between and be handled by the traditional hearing mechanism. A candidate number for the lower bound, at least initially, is the utility of the do-nothing (i.e., status quo) alternative, for obvious reasons. If what the applicant wants is not clearly better than the status quo, why does he deserve a hearing? As experience and confidence in the multiattribute utility measurement system develop, the two bounds can be moved toward each other, so that more and more cases are handled automatically rather than by means of hearings. This process need work no hardship on any rejected applicant; he can always appeal, accepting the delays, costs, and risk of losing implicit in the hearing process rather than investing in upgrading his plan. And the regulatory agency, by moving the boundaries, can, in effect, control its case load and thus gradually shorten the frequently inordinate delays of current procedures.

Although I know of no public context in which even limited experimentation with the methods advocated here is occurring, I have hopes.

12.3 EXAMPLE 2: PLANNING A GOVERNMENT RESEARCH PROGRAM

The Office of Child Development (OCD) of the U.S. Department of Health, Education, and Welfare (HEW) has a variety of responsibilities. Perhaps the largest is the operation of Project Head Start, a very large program for encouraging the development of preschool children that is not included in this example. It also sponsors a research program concerned with methods for promoting child welfare, for dealing with specific problems of children, and the like.

In the fall of 1972, OCD was faced with the task of planning its research program for fiscal 1974, which began on July 1, 1973. Guidance from the Department of Health, Education, and Welfare indicated that this research program, unlike its predecessors, would have to be justified by means of some assessment of its costs and benefits. While OCD staff members knew how to assess the cost of a research program, they had considerable difficulty in thinking about how to assess its benefits in quantitative form. To perform the assessment, Marcia Guttentag, Kurt Snapper, and I were brought in as consultants, to work, primarily with John Busa of OCD, on the analysis. A fuller report of this project has been published by Guttentag and Snapper (1974).

The ten-step process specified earlier in this paper was used. Initially, we assumed that the organization whose utilities were to be maximized was OCD; we later learned that this was a considerable oversimplification. We also assumed that the entities to be evaluated were proposed research programs; this initial assumption, too, turned out to be excessively simplistic.

12.3.1 ELICITATION

Step 4. To carry out Step 4, OCD brought together for 2 days a group of 13 people – OCD administrators and staff, both from Washington and from OCD field offices all over the country, plus several academic experts on child development. At my insistence, the value dimensions were segregated into two lists, one concerned with benefits to children and families and the other concerned with benefits to OCD as an organization. The reason for the distinction is that in previous applications of the method, I had found that dimensions that were in fact concerned with organizational survival and growth were frequently couched in language that suggested that they referred to fulfillment of the organizational mission; organizations are often unwilling to admit the importance of survival and growth in their decisions. Thus, for example, a dimension that in fact was “Enhance the impact of OCD on federal programs related to child health” might appear as “Promote child health.” It seemed to me that a clearer picture of OCD’s actual values could be obtained if the values associated with organizational survival and growth were segregated from those concerned with fulfillment of its mission, so that each class of values could be dealt with separately.

Initial lists of value dimensions (called goals or criteria, in order to facilitate communication with the respondents) in each of the two groups were elicited by inviting the participants to state those goals; each list ended up with 35 to 40 goals on it. A major task was then to pare the lists down. Early eliminations were easy because some of the goals were simply restatements of others in slightly different language or because everyone agreed that a particular goal was not important enough to be worth considering or that it was not relevant to designing a research program. Later, further paring of the lists was accomplished by having each participant rank-order the importance of the goals in each list separately and then proposing that goals that were low on most rank orders be deleted. This process produced many deletions; more important, it produced extremely searching and sophisticated discussions of just what each goal meant, how it related to other goals, and what sort of research or other action might achieve it. These discussions combined with the social effects of face-to-face interaction to produce considerably more agreement about the meanings of the various goals and their relative importance than would have occurred otherwise, though, of course, the agreement was very far from complete.

Steps 5 and 6. Each participant in the process was then asked individually to perform Steps 5 and 6. All 13 forms were returned with usable ratings. A few more

goals were eliminated on the basis of these ratings, essentially on the argument that they contributed 5 percent or less to total importance and respondents seemed rather well-agreed on their low level of importance. Of course, with all the low-rating dimensions eliminated at various stages along the way, the remaining high-importance dimensions showed considerable interpersonal disagreement. Careful analysis showed that disagreement was not systematically related to the race, sex, or organizational locus of the respondent.

The Acting Director of OCD assigned final importance weights, mostly in good agreement with the means of the 13 respondents. He also made judgments relating importance weights across the two lists – values to children and families and values to OCD. These judgments permitted the consolidation of the two lists, with their separate importance weights, into one list:

Criterion A (Importance weight = .007) The extent to which a recommended activity is likely to foster service continuity/coordination and elimination of fragmentation, or is likely to contribute to this goal.

Criterion B (Importance weight = .145) The extent to which a recommended activity represents an investment in a prototypical and/or high-leverage activity or is likely to contribute to the development of prototypical/high-leverage programs.

Criterion C (Importance weight = .061) The extent to which a recommended activity increases or is likely to contribute to an increase in families' sense of efficacy and their ability to obtain and use resources necessary for the healthy development of children.

Criterion D (Importance weight = .052) The extent to which a recommended activity is likely to increase the probability that children will acquire the skills necessary for successful performance of adult roles, or is likely to contribute to that goal.

Criterion E (Importance weight = .036) The extent to which a recommended activity is likely to contribute to making the public and institutions more sensitive to the developmental needs of children.

Criterion F (Importance weight = .048) The extent to which a recommended activity is likely to promote the individualization of services or programs, or is likely to contribute to this goal.

Criterion G (Importance weight = .043) The extent to which a recommended activity is likely to stimulate the development of pluralistic child care delivery systems that provide for parental choice, or is likely to contribute to the expansion of such systems.

Criterion H (Importance weight = .014) The extent to which a recommended activity is likely to promote self-respect and mutual regard among children from diverse racial, cultural, class, and ethnic backgrounds, or is likely to contribute to this goal.

Criterion I (Importance weight = .009) The extent to which a recommended activity is likely to result in effective interagency coordination at federal, state, and local levels, or is likely to contribute to this goal.

Criterion J (Importance weight = .160) The extent to which a recommended activity is consonant with administration and departmental policies and philosophy or reflects prevailing public and social thinking.

Criterion K (Importance weight = .120) The extent to which a recommended activity is likely to make public leadership more sensitive to the needs of children.

Criterion L (Importance weight = .145) The extent to which a recommended activity is likely to influence national child care policy in a positive way.

Criterion M (Importance weight = .032) The extent to which a recommended activity is capable of rational explication, that is, the extent to which it represents a logical extension of past results and conclusions, is indicated on theoretical grounds, or fulfills prior commitments.

Criterion N (Importance weight = .129) The extent to which a recommended activity is likely to produce tangible, short-term results, that is, the extent to which it is likely to produce or contribute to the production of solid conclusions, benefits, or results within a relatively short period of time.

The dimensions had acquired considerably more careful definitions along the way. Of the five criteria receiving importance weights of .10 or more, four came from the list of values to OCD rather than from the list of values to children and families. Even Criterion B, which was on the list of values to children and families, might have been on the other list as well. These findings should be no surprise to students of administrative and bureaucratic decision making. They should, however, give researchers reason to pause for thought. Especially interesting was the fate of one goal that had appeared on the first list of values to children and families: "Contribute to knowledge expansion and/or use of knowledge for program planning." This was easily eliminated as relatively unimportant. At the time, I found its elimination baffling, since I had been told that the goal of the exercise was to evaluate research proposals. As it turned out, this was not the goal of the exercise; I had failed to perform Step 3 properly. Moreover, OCD is an organization interested in applying knowledge to problems. Its programs are mostly action-oriented. New knowledge is important only if it can lead to more effective action. Consequently, the value of new knowledge should derive from its contribution to action goals. Thus, the elimination of a goal that in effect valued knowledge for its own sake was consistent with the basic mission and value structure of OCD.

Step 3. When this subject started, I had naively supposed that OCD received a flow of research proposals and that we were to develop a method of deciding which ones to implement or fund. Actually, OCD projects start as statements of research priorities or as Requests for Proposals. The question of what we were trying to evaluate might have been handled much better if I had understood more clearly at the outset how the process by which OCD generates its research program differs from the process by which some other HEW agencies, such as the National Institutes of Health, generate theirs.

Still, we supposed that we were trying to evaluate specific research activities. These activities came from many sources. Major reports to OCD and HEW were summarized, and their recommendations were, where appropriate, restated as research projects. Recommendations of possible research projects were obtained from many members of the OCD staff, from the Office of the Assistant Secretary for Planning and Evaluation in HEW, and from many other interested government and private groups. Several hundred recommendations were assembled, combined, and refined as a result of this process. For specificity, a proposed duration and cost

was attached to each. Most of these were in the range of 1 to 3 years and \$50,000 to \$1,500,000.

Step 8. Informal screening was used to reduce the output of Step 3 to a smaller and more manageable set; ultimately, 56 research recommendations were carried through the entire analysis. Of these, six were obviously unattractive and were included in order to facilitate location of a true zero point on the aggregate utility scale. Each of these 56 recommendations was scaled on each of the 13 dimensions of value by three members of the OCD staff independently — $56 \times 13 \times 3 = 2,184$ judgments in all. Interjudge reliability was generally quite good, considerably higher than it had been for the importance weights and quite high enough that we had no compunctions about taking the average over the three judges as the scale value for each research project on each dimension. The projects scattered out well over each dimension. For example, for dimension H the range was from 880 to 260; for dimension G the range was from 470 to 25.

Step 9. Now, calculation of utilities for each recommendation required no more than multiplication and addition. The range of aggregate utilities for the 56 research recommendations was about 550 to about 200, and the distribution was well spread out over that range; the mean was 369 and the standard deviation of the 56 utility values (on that scale) was about 71.5. For convenience, the scale was stretched out by a linear transformation so that the lowest aggregate utility was 0 and the highest was 1,000. On this new scale, the mean was 483 and the standard deviation was 204.

The next step, since we wanted to look at benefit-to-cost ratios, was to see if the utility scale had a locatable true zero point. The Acting Director of OCD was asked whether there were any projects on the list that he would not wish to have OCD sponsor even if they cost nothing. There were ten such projects, including all six of the ones that had been left in for this purpose. A cutting score of 295 (on the 0-to-1,000 rescale utility function) identified them with only one inversion, so 295 was adopted as the zero point of the 0-to-1,000 utility scale (which thus became a 0-to-705 scale); projects falling below that score were dropped from consideration, and benefit-to-cost ratios were calculated for the rest. Ordering in cost–benefit ratios, of course, differed from ordering in benefits alone.

Step 10. Our failure to perform Step 3 properly now caught up with us. The process by which we had produced proposed research topics was casual and *ad hoc*, and the results showed it. The proposed topics did not cover all important substantive areas of research on child development and were not well formulated with respect to the topics they did cover. Moreover, by this time we had a somewhat better understanding of the role the evaluative machinery we had developed could play. It was not well designed to evaluate specific research projects, but it could evaluate higher-order questions having to do with directions in which programs of research might go.

Step 3 again. Working with OCD scientists, we developed a comprehensive taxonomy of research areas, taking into account those that had been omitted as well as those that had been included in the previous list of research projects. This pro-

duced a short list of general research foci under which most of the previously generated specific projects could be subsumed.

Step 10 again. Using only the five value dimensions with highest weights, each general research focus was evaluated. A rough rule-of-thumb was proposed: each research focus should receive a proportion of the available funds proportional to its utility. The Acting Director of OCD, with value dimensions in hand but without knowing the utilities of the research areas, made a tentative allocation of funds. This allocation was compared with the result of the rule-of-thumb. The relationship was close, though not perfect. The Acting Director reduced the funding of areas that received too much by that rule-of-thumb and increased the funding of areas that received too little. A comparison of the 1973 and 1974 research budget allocations clearly showed that changes did occur in these directions and in amounts close to those suggested by the rule-of-thumb.

12.3.2 CONCLUSION

In retrospect, the most serious deficiency of the procedure was our failure to perform Steps 1, 2, and 3 in time. Step 1 caused difficulties; not only the values of OCD but also those of reviewing organizations within HEW were relevant and should have been ascertained. The most important failure, however, was that the procedures for performing Step 3 were hasty and *ad hoc* and resulted in unsatisfactory lists of research recommendations. This failure ultimately forced the decision process to a much higher level of abstraction, at which broad research areas rather than specific projects were evaluated.

While this was not what we had originally had in mind, it may have served OCD well. The value dimensions originally elicited from OCD staff members and others were not particularly appropriate to evaluating specific research projects. They did not address such questions as the feasibility of the project, how it related to what had already been done, the extent to which it advanced knowledge in some significant area, and so on. On the other hand, those dimensions did address the question "What do OCD staff members value?" They are more appropriate for broad programmatic guidance than for evaluating specific projects. Developing a second mechanism suitable for evaluating specific responses to statements of OCD research priorities or Requests for Proposals would have been an interesting and valuable exercise in using hierarchical value structures. Such an evaluative mechanism would measure congruence of the responses with OCD's broad values as reflected in the requests that stimulated them, while at the same time measuring the congruence of those responses with the general criteria one uses to evaluate social science research projects. But we were not asked to do that.

The methods used to obtain value dimensions and importance weights seemed to work well in a technical sense. The extensive use of group discussion, interspersed with ratings and reratings, considerably enhanced OCD's awareness both of its own values and of value conflicts within its staff and, in the process, did much to

reduce those conflicts. In retrospect, this was by far the most important and useful outcome of the project.

The finding of relatively high reliability of location measures, even on these very abstractly defined dimensions and with rather poorly defined research projects, was expected but gratifying. Location measurement is a matter for expertise, and these judges were experts in the field. The ease with which a true zero point for utility was defined, and its precision, was surprising. One interesting reason for the precision of the zero point may well have been that only one respondent was asked to make that particular set of judgments.

The difficulties at the decision stage resulted, of course, directly from the failure to define the decision options clearly enough early enough. That is one mistake I believe I have learned not to make again.

12.4 EXAMPLE 3: INDICES OF WATER QUALITY¹

In 1968, the U.S. National Sanitation Foundation (known as NSF, but not to be confused with the National Science Foundation) published an index of water quality based on an additive combination of measures of nine parameters of water. The judgments were collected from more than 70 water quality experts. However, the index did not distinguish among possible uses of water and so left unanswered the question of whether different indices might be appropriate for different purposes. O'Connor (1972, 1973) set out to answer that question by developing two different indices. One described the quality of a surface body of water that is to be treated if necessary and used as a public water supply (PWS). The other described the quality of a surface body of untreated water from the point of view of its ability to sustain fish and wildlife (FAWL). O'Connor's approach was to develop multiattribute utility models for each use and then to examine the relationship between these models. At least moderate correlations were inevitable, but absence of very high correlations would indicate that at least two indices of water quality were needed.

12.4.1 PROCEDURES

Eight experts on water quality located all over the country were the subjects. Four were university professors; the others were officials of organizations responsible for water supplies. In a mailed questionnaire, the experts were asked to rate the importance of each of 36 parameters for water for each of the two uses on a 0-to-100 scale by assigning 100 to the most important parameter and rating others relative to that parameter. (A variant of my proposed procedure, this one has the advantage that experts usually agree better on what is most important than on what is least

¹ The work summarized in this example was performed by Dr. Michael F. O'Connor (1972) as his Ph.D. thesis.

important, but it also has the disadvantage of making it more difficult to preserve the ratio properties of the weight estimates.)

In a follow-up visit by O'Connor, each expert selected a subset of about 12 of the original 36 parameters and rerated the importances of those he had selected. He also drew a function relating the relevant physical parameter continuum (e.g., pH) to quality; the function was required to have its maximum at 100 and its minimum at 0.

On the basis of the results of this visit, a second questionnaire, feeding back to each expert the results from all respondents and asking for a rerating of importances, was sent out. A second visit followed. For the second visit, the list of parameters was reduced to 17 for PWS and 11 for FAWL, in part by deletion of parameters considered by other experts not otherwise participating in the study to be redundant. The goal of the second visit was to achieve consensus on both importances and functions relating parameters to quality. The main tool used for this purpose was displays of all judgments obtained from the second questionnaire and of average weights and functions. No expert objected to the parameter deletions; indeed, as a result of the second visit four more parameters were deleted from the PWS list and two from the FAWL list. Table 12.2 shows the final parameters and normalized average importance weights. Most of the judges were willing to accept the average functions relating each physical parameter to quality as adequately representative of their own opinions, but they were much less willing to accept the average weights. The final functions, averaged over experts, relating water quality to physical parameters were also accepted by most of the experts.

Finally, a number of imaginary water samples were prepared, described by a parameter values on the relevant dimensions. Each expert was told the parameters of

TABLE 12.2 Final Parameters Chosen for Inclusion in the PWS and FAWL Indices, with Corresponding Normalized Average Importance Weights

PWS		FAWL	
Parameter	Normalized Weights	Parameter	Normalized Weights
Fecal coliforms	.171	Dissolved oxygen	.206
Phenols	.104	Temperature	.169
Dissolved solids	.084	pH	.142
pH	.079	Phenols	.099
Fluorides	.079	Turbidity	.088
Hardness	.077	Ammonia	.084
Nitrates	.070	Dissolved solids	.074
Chlorides	.060	Nitrates	.074
Alkalinity	.058	Phosphates	.064
Turbidity	.058		
Dissolved oxygen	.056		
Color	.054		
Sulfates	.050		

the sample, the scaled values for PWS and FAWL developed from the averaged data, those obtained from the expert's own weights combined with the average curves, and how the sample would score on the previously developed NSF index of water quality. The experts were invited to inspect these indices and change any they felt to be incorrect. All correlations among indices for the same use were very high; the lowest correlation between an average index and one prepared from an individual expert's judgments was .922, and when he changed some judgments the correlation rose to .956. Intercorrelations among PWS, FAWL, and the earlier NSF index were moderate, generally in the range from .6 to .8. Clearly, use does make a difference; a single water quality index is not good enough.

Linear approximations to the average curves were tried and generally produced very high correlations (e.g., .968) with the indices based on the average curves. An exception arose for certain water samples (chosen for realism) and the FAWL index, where the linear approximation produced correlations with the nonlinear index of about .70. This exception resulted from bad fits between the nonlinear function and its linear approximation for phosphates, turbidity, and dissolved solids, all of which were highly variable in the realistic water samples.

12.4.2 COMMENTS

Most of the rather forceful methods used to obtain agreement in this study were made necessary by shortage of time with each expert and lack of opportunity for face-to-face discussion among the experts. While this procedure is not well designed to make experts feel happy with the final outcome, it did produce PWS and FAWL indices that seem serviceable for most purposes and that are clearly different. Face-to-face procedures would probably have produced very similar results but would have left the experts feeling happier about the indices finally developed.

O'Connor had considerable difficulty in getting his experts to understand the importance weighting method he used. It is unclear whether the difficulties were caused by shortage of time to explain and practice, or by the method itself; I suspect both contributed.

Both the experts and O'Connor had difficulties with the additive model. One difficulty had to do with toxic substances, such as pesticides. Both indices were made conditional on absence of these substances; their inclusion in even small concentrations would have made the quality of the water unacceptably low, in the opinion of these respondents.

The other difficulty is more instructive. Both pH and fecal coliforms were important for PWS, but fecal coliforms were more than twice as important as pH. Low pH values (i.e., acid water) will kill the fecal coliforms and so may actually increase water quality. This relationship, so far, is clearly an instance of environmental correlation, not of violation of the underlying additive value model. However, a pH as low as 3.0 produces water so unsatisfactory as an input to PWS that its quality is zero regardless of its merits on the other dimensions. Consequently,

at this low pH level, the additive value model is violated. O'Connor handled this problem by using the additive model above 3.0 pH, and defining any water with pH of 3.0 or lower to have quality 0 for PWS. This definition produces an ugly discontinuity in the model but is otherwise unimportant, since a pH of 3.0 or anywhere near it is rare indeed in water being considered as input to PWS.

12.5 CONCLUSION

This paper has reviewed three attempts to use multiattribute utility measurement with a number of expert respondents in more-or-less applied settings. Three very different approaches to the problem of interpersonal disagreement are illustrated by the three examples. All seem to work. Comparing them, I feel that the procedure that used face-to-face discussion most (the OCD example) was most successful in producing agreement; procedures depending on indirect feedback of other experts' judgments were clearly less successful.

All three examples underline, in my view, the importance of simplicity in elicitation procedures. Amounts of respondent time ranged from a minimum of 6 hours to a maximum of 2 days per respondent in these examples; that is simply too short a time to teach any expert how to make sophisticated judgments about preferences among imaginary bets and then collect a useful set of judgments from him, especially if a great deal of that time is taken up, as it should be, with discussion between him and other experts about the substantive issues lying behind the judgments.

So important does this issue of simplicity seem to me that our next major study will examine the following question: How well can a multiattribute utility measurement procedure do by using an additive model, linear single-dimension utility functions for monotonic dimensions, and importance weights of 1, 0, and -1 only? The literature on unit weighting in multiple regression (e.g., Dawes and Corrigan, 1974; Einhorn and Hogarth, 1975) suggests that unit weighting may work surprisingly well, as does the literature on combining subtests (e.g., Wilks, 1938). I expect that high negative environmental correlations among dimensions of value can make such an approximation too simple. Still, if such an approximation isn't too bad, what an enormous simplification of elicitation methods it offers us!

REFERENCES

- Arrow, K.J. 1951. *Social Choice and Individual Values*. John Wiley, New York.
- Bauer, V., and M. Wegener. 1975. Simulation, evaluation, and conflict analysis in urban planning. *Proceedings of the IEEE*, Vol. 63, pp. 405-413.
- Dawes, R.M., and B. Corrigan. 1974. Linear models in decision making. *Psychological Bulletin*, Vol. 81, pp. 97-106.
- Edwards, W. 1971. Social utilities. *The Engineering Economist, Summer Symposium Series*, Vol. 6, pp. 119-129.

- Edwards, W., and M. Guttentag. 1975. Experiments and evaluations: a re-examination. In *Experiments and Evaluations* (C. Bennett and A. Lumsdaine, eds.). Academic Press, New York.
- Edwards, W., M. Guttentag, and K. Snapper. 1975. Effective evaluation: a decision theoretic approach. In *Handbook of Evaluation Research* (M. Guttentag, ed.). Sage, Beverly Hills, California.
- Einhorn, H.J., and R.M. Hogarth. 1975. Unit weighting schemes of decision making. *Organizational Behavior and Human Performance*, Vol. 13, pp. 171–192.
- Gardiner, P.C. 1974. The application of decision technology and Monte Carlo simulation to multiple objective public policy decision making: a case study in California coastal zone management. Ph.D. thesis. University of Southern California.
- Gardiner, P.C., and W. Edwards. 1975. Public values: multi-attribute utility measurement for social decision making. In *Human Judgment and Decision Processes* (S. Schwartz and M. Kaplan, eds.). Academic, New York.
- Guttentag, M., and K. Snapper, 1974. Plans, evaluations, and decisions. *Evaluation*, Vol. 2, pp. 58–74.
- Keeney, R.L. 1972. Utility functions for multi-attributed consequences. *Management Science*, Vol. 18, pp. 276–287.
- Keeney, R.L. 1974. Multiplicative utility functions. *Operations Research*, Vol. 22, pp. 22–34.
- Keeney, R.L., and H. Raiffa. 1976. *Decisions with Multiple Objectives*. John Wiley, New York.
- O'Connor, M.F. 1972. The application of multi-attribute scaling procedures to the development of indices of water quality. Ph.D. thesis. University of Michigan.
- O'Connor, M.F. 1973. The application of multiattribute scaling procedures to the development of water quality. Report 7339. Center for Mathematical Studies in Business and Economics, University of Chicago.
- Raiffa, H. 1968. *Decision Analysis: Introductory Lectures on Choices under Uncertainty*. Addison-Wesley, Reading, Massachusetts.
- Raiffa, H. 1969. Preferences for multi-attributed alternatives. RM-4968-DOT/RC. The Rand Corporation, Santa Monica, California.
- Torgerson, D. 1973. Venice: everything is changing, middle-income hippies moving in where poor are moving out. *Los Angeles Times*, November 18.
- Wilks, S.S. 1938. Weighting systems for linear functions of correlated variables when there is no dependent variable. *Psychometrika*, Vol. 3, pp. 23–40.

DISCUSSION

JACQUET-LAGREZE: You spoke of taking uncertainty into account by assigning probabilities to a set of scenarios. How do you proceed?

EDWARDS: In none of the cases in this paper was uncertainty considered. However, there are other instances in which I have been involved that do consider very elaborately conceived uncertainties. We assign probabilities to a variety of scenarios and work with expected utility on the basis of those probabilities and utility models. In those situations the utility functions are much more complicated. You almost invariably find that the preferred model forms for the respondent involve both additive and multiplicative components. The reason is very simple: Some dimensions are just so overwhelmingly important that if a particular entity being evaluated scores zero on that dimension, you want it to have a zero score overall. A simple additive model would not do this.

There is no fundamental difference between working with the mixed models and working with the simple additive model that I discussed in my paper. The technique for assigning scenario probabilities is judgmental, as you would expect. Compared to probabilities, odds have the enormous advantage of not getting you involved in normalization difficulties; people can do very well at making odds judgments. While there are a variety of technical problems inherent in using mixed models, a discussion of them here is inappropriate. The most important of them is that “scenario footprints” should be of nearly constant size – that is, you don’t have one great big global scenario and one little tiny scenario.

MacCRIMMON: I am a bit confused about what you meant at the outset by rejecting hypothetical questions. What I thought you were going to do was take real choices made by real decision makers and infer something about their values. This is called the revealed preference approach in economics. What I thought you objected to at that point was somebody sitting at a computer console being fed hypothetical choices. However, as you went on, you required people to give judgments about importance numbers – whatever that means – and value numbers – whatever that means. To me, these numbers seem about as hypothetical as you can get.

EDWARDS: I have to agree that these are indeed hypothetical. However, they are not completely hypothetical because the respondents are well aware of how they will be used. One of the ingredients in this whole process is to take individuals through this assessment procedure at the level of examples, so that when they make such judgments they know what is going to be done with them. The intuition that they develop seems to be useful.

One of the reasons I advocate such assessment procedures is that I have tried choices using imaginary betting techniques and have gotten the most overwhelming rejection that you could ever wish to see. I was startled at the unanimity with which untrained respondents reject such elicitation procedures, although they are not at all unwilling to rank dimensions in order of importance. They do not seem to have much difficulty with the task once they know how the numbers they produce are going to be used. It is also not necessary to offer a very sophisticated or complicated explanation of the use of the numbers.

13 The Use of Decision Analysis in Capital Investment Problems

Arnoldo C. Hax and Karl M. Wiig

13.1 INTRODUCTION

A capital investment usually consists of the allocation of large amounts of money with plans for recouping the initial investment plus adequate profits (or other returns) from cash flow (or other benefits) generated during the economic life of the investment. The decisions associated with these allocations of funds ordinarily are the responsibility of a firm's top executives, and these decisions constitute the major tools used to implement the strategic actions of an enterprise. Capital investments are required to strengthen and renew the resources of a firm.

Once investments are made, the decisions are very hard to reverse without severely disturbing an organization economically and compromising its ability to achieve its goals. Thus, capital investment decisions require careful analysis and are among the most difficult and important decisions managers have to make.

There are certain constant characteristics of capital investment decisions that must be emphasized at this point because they are important to the methods used to analyze the consequences of these decisions:

Time When large amounts of money are committed, the impact of this action is felt for many years in the organization. The long-lasting effects of capital investment decisions imply that long planning horizons – 10 to 20 years or more – should be adopted in analyzing them. This forces recognition of the time value of money (that is, a dollar spent or earned today is worth more than a dollar spent or earned in the future). Normally, the difference in value of money through time is taken into consideration by discounting the cash flows generated by the investment during the planning horizon. The discount rate used for this purpose should reflect the opportunity cost that is incurred when available funds are devoted to a given investment. When ample funds are available to an organization, the discount rate should be at least equal to the interest paid in borrowing money or to the return on

investment from other ventures or programs. Time values can also be attached to flows of benefits other than money (such as commodities) through the planning horizon of the investment problem.

Uncertainties The long-lasting consequences of the investment decision create uncertainties. Indeed, the cash flows that are expected through the life of the investment are not known with certainty, nor are critical factors such as market shares and raw material supplies. Ignoring these uncertainties results in a severe oversimplification that may lead to the selection of a poor investment alternative.

Risk Uncertainties create an environment in which risk attitudes play an important role. It has long been recognized that investors are ordinarily risk averse, their degree of risk aversion depending on their personal preferences, their present assets, and the nature of the uncertainties they have to face. A complete analysis of an investment decision has to provide the decision maker with the means to evaluate properly the implications of his risk attitudes in each strategy option that is being considered.

Trade-offs between multiple objectives The selection among competing alternatives cannot be resolved, in many practical applications, by means of a single objective or attribute. In these cases it is necessary to provide a mechanism that allows evaluation of the trade-offs existing between multiple objectives.

We describe in this paper an analysis that was conducted to deal with a capital investment decision facing a major U.S. mining company. The approach followed in this analysis includes a systematic treatment of time, uncertainties, risks, and multiple-objective trade-offs. We believe this approach can serve as a general framework for other investment problems of the same type.

The conceptual basis for our approach may be found largely in the field of decision analysis (see, for example, Raiffa, 1968; Schlaifer, 1969; and Keeney and Raiffa, 1976). Similar applications of decision analysis to capital investment problems have been reported by Howard (1968a) and by Spetzler and Zamora (1971).

13.2 CHARACTERISTICS OF THE CAPITAL INVESTMENT DECISION

Two things should be clearly understood before an investment decision analysis is undertaken: what decision is about to be made and who the decision makers are.

A decision (as defined by Howard, 1968b) is an irrevocable allocation of resources – irrevocable because it would be impossible or too costly to reverse the decision after it has been made. This implies an actual commitment of funds by management. The definition of the investment decision requires a great deal of creativity, not only to identify the most attractive opportunities for capital investment, which determines the environment in which the decision has to take place, but also to construct all the relevant alternative ways of approaching that decision that are open to the decision maker. These efforts, which Simon (1960) refers to as the

intelligence and design phases, respectively, are perhaps the hardest parts of decision making, and the ones that have received least attention from both traditional and scientific management schools. It is here that the natural talents of individual managers are tested the most. Our approach provides a systematic way to structure the elements of a given decision so as to facilitate the selection of the most promising alternative. This is what Simon calls the *choice phase*. The approach takes as input the definition of the investment problem; therefore, it does not contribute to the process of identifying investment opportunities (the intelligence phase). By providing easy ways of testing and evaluating new alternatives, it might contribute only indirectly to the design phase.

The second basic element of the capital investment problem is the identification of the decision maker (or decision makers). As we will see, this is an essential element since we need to know (a) the scope of the analysis, (b) the decision options that the decision maker(s) wants to consider, (c) his attitude toward risks, and (d) the trade-offs he is willing to make at various levels of outcomes. This approach calls for personal interaction with the decision maker: dealing with an individual is significantly different from dealing with a group of individuals making a collective decision.

13.3 GENERAL DESCRIPTION OF THE INVESTMENT PROJECT

A major mining company found its supply of ore running short and hence entertained projects to increase its supply. An opportunity for decision making presented itself at the beginning of 1973, when the U.S. Government offered for bids two parcels of land with extensive ore deposits. There were two major decisions to be made in this situation:

1. *The bidding decision*, which consisted primarily of:

The amount to bid for each parcel

Whether to bid alone or with a partner

The bids were to be submitted 2 weeks apart, with the second bid submission after the results of the first were known. Only one government parcel was sought. Bidding with a partner had the advantages of obtaining a greater level of expertise and of sharing the risk associated with the venture but had the disadvantage of providing a smaller share of the benefits (production and value) to be derived from the venture.

2. *The production decision*, which consisted of the way in which existing company ore deposits or those added by the bidding were to be developed and operated. There were two options:

Develop and operate plant alone (available only if government parcel A or B were won)

Develop and operate plant with a partner

If bidding were successful, the government property would be developed. If the bid were to be won with a partner, the partnership would be extended to the exploitation phase. If the bidding were unsuccessful, a partnership with an owner of adjoining land would be required, since the deposits currently owned by the firm were not enough to allow a large-scale exploitation. Moreover, the company was considering heavy investment in another venture; a final decision on this venture was expected in the fall of 1973. If funds were committed to this venture, the company would be forced to develop the project analyzed herein with a partner. In the following analysis we will refer to this project as the "competing venture."

In most investment projects the total plant capacity is a decision variable. Because of the technology involved in the mining operation, the total annual capacity of the plant was given directly as a function of the size of the available ore deposits, which were already well known from previous assessments in each case.

The major alternatives in our investment decision have been described. The following are significant factors in the analysis of these alternatives:

The project had a planning horizon of 28 years: 3 years of engineering studies and plant design; 5 years of construction; 20 years of plant operation (economic life of investment).

Great uncertainties were associated with the required mining technology and the future product prices.

The total capital commitments were of the order of \$500 million.

The president was the single decision maker because of his authority and personal interest in the problem.

13.4 MODELING AND DATA COLLECTION PHASE

Having defined the decisions and selected the major alternatives, we proceed to a brief description of our model of the investment problem. More details of the model, as well as discussion of alternatives to our assumptions, are found in Hax and Wiig (1975).

13.4.1 SELECTION OF A PLANNING HORIZON AND NUMBER OF TIME PERIODS

The planning horizon indicates how far into the future we have to look to take into account all the significant outcomes of the investment decision. The planning horizon extends from the present until the end of the economic life of the investment project. Ordinarily, it includes feasibility studies and construction periods preceding the operating phase of the investment. As mentioned above, a planning horizon of 28 years was selected for our project. This planning horizon was divided into periods of 1 year.

13.4.2 SELECTION OF THE DECISION VARIABLES

Decision variables are those factors that are under the control of the decision maker. The ultimate purpose of this analysis is to provide guidance to the decision maker with regard to the optimal values for the decision variables. As we have explained in the general description of the investment project, the decision variables in this case are:

1. Bidding alone or with partner first for property A, and then, if unsuccessful, for B
2. Deciding how much to bid for properties A and/or B
3. Developing and operating deposits alone or with partner

Recall that neither plant capacities nor alternative mining processes were decision variables in this case. Variables 1 and 3 are bivalued. Variable 2 is a continuous variable that can assume an infinite number of values. However, it is common practice in decision analysis to discretize such variables to a limited number of options to reduce the computational burden. For these reasons, we confined our analysis to three bidding values – high, medium, and low – for each property.

13.4.3 SELECTION OF PARAMETERS

Parameters (exogenous variables) are those elements of the problem (such as prices, costs, and demand) that, imposed by the external environment, are beyond the control of the decision maker. In our project the most important parameters associated with the investment decision were

- Schedule and magnitude of capital investment (by year and by category):
 - Land and preparation
 - Mining plant
 - Ore upgrading plant
- Product market prices
- Plant capacity
- Operating costs
- Tax rates (corporate income tax rate; investment tax credit rate; and depletion allowance rate)
- Depreciation (periods and methods for book and tax depreciation for each cash flow category)
- Inflation rates over planning horizon
- Fraction of capital investment subject to investment tax credit

In addition, there are parameters associated with the probabilities of winning bids and success of the competing venture. Since our project was to be financed entirely by internally generated funds, interest rates were not considered.

There is some arbitrariness in the distinction made between parameters and decision variables, and one could argue that, for a certain price, most parameters can be subject to some degree of control by the decision maker. For instance, the demand for products can be altered by advertising and promotions, and costs and prices can be changed. We can always start, however, from a reference point that defines the appropriate values for the parameters and insert as decision variables those actions the decision maker can take (like promotions or advertising expenditures) to change the initial values of the parameters.

13.4.4 CASH FLOW PROJECTION MODEL

The basic objective of the cash flow projection model is to determine the stream net annual cash flows after taxes over the planning horizon. The relation that defines the net annual cash flow is

$$\left(\begin{array}{c} \text{Net Cash Flow} \\ \text{after tax} \end{array} \right) = (\text{Revenue}) - \left(\begin{array}{c} \text{Capital Investment} \\ \text{or Capital Charges} \end{array} \right) - (\text{Operating Cost}) - (\text{Tax})$$

The model used to calculate each component in this equation for each time period is found in Hax and Wiig (1975).

13.4.5 TRANSFORMATION OF CASH FLOWS INTO A SINGLE PROFITABILITY MEASURE

In order to compare the cash flows generated by the decision alternatives, it is convenient to reduce them to a single measure of profitability. This measure of profitability should provide a consistent indicator of the preferences of the decision maker toward alternative cash flows, so that if the decision maker prefers the cash flow associated with alternative *A* to the one associated with alternative *B*, then the profitability measure of *A* should be greater than that of *B*.

Although several measures of profitability have been proposed (see, for example, Bierman and Smidt, 1966), we strongly recommend that net present value (NPV) be adopted for this purpose in capital investment decisions. In order to obtain the NPV of a stream of cash flows, it is necessary to define a discount rate. The classical approach to this issue is to select as the discount rate either the cost of capital (Modigliani and Miller, 1958; Solomon, 1963) or the decision-maker marginal opportunity rate. Another approach, which is more consistent with the decision analysis way of thinking (Howard, 1968a; Spetzler and Zamora, 1971), is to consider the discount rate as a statement of time preference on the part of the decision maker.

It is important to emphasize that this discount rate should not be inflated to incorporate margins for uncertainties or risks. Doing this will only confuse the treatment of the time preferences in the reception of the cash flows with the uncertainties inherent in the magnitude of these cash flows and the risk attitudes of the decision maker toward these uncertainties. So far, we have purposely

excluded from our analysis uncertainties and risk considerations. These issues are treated below.

13.4.6 SELECTION OF OBJECTIVES AND MEASURES OF EFFECTIVENESS

So far, we have limited ourselves to analyzing the investment decision in terms of its cash flow implications. The transformation of the cash flow stream into a single measure of profitability, discussed in the previous section, provides the specification of a criterion and a measure of performance that could be of great assistance in distinguishing the relative merits of the various alternatives the decision maker faces. In fact, many investment opportunities in the private sector can be properly decided upon if profit maximization (or cost minimization) is treated as the single objective. However, in some applications it is extremely difficult to identify a unique objective that represents adequately the preferences of the decision maker with respect to the outcomes of his decisions. It could be that there are several attributes that he considers important (profit, share of market, employment stability, customer satisfaction, and so on). For our project the decision maker felt it was essential to incorporate two objectives into the analysis: *maximization of profit*, as measured by the NPV of the projected cash flows, and *maximization of product output* available to the company from the venture after the partner's share has been subtracted.

13.4.7 IDENTIFYING PARAMETERS WHOSE UNCERTAINTIES MUST BE TREATED EXPLICITLY

Although, in rigorous terms, the potential values of every parameter of the problem over the duration of the planning horizon are subject to some degree of uncertainty, the impact that those uncertainties have on the selected objective(s) (say, the NPV of the investment) can be quite different. In many cases, therefore, it is possible to classify the parameters into two groups: the deterministic parameters and the uncertain parameters.

Deterministic parameters are those whose uncertainties can be ignored without causing undue oversimplifications in the analysis because the expected range of variability of the parameters is small or the change of the objective's value within the range is negligible. Their values will be assigned constant numbers, usually the most likely values or "best single estimates" available, in each period of the planning horizon.

Uncertain parameters, also called critical parameters, are those whose uncertainties must be properly recognized and dealt with; otherwise, a critical element of the problem will be overlooked, and the wrong alternative might be chosen.

Significant uncertainties were associated with the bidding process since it was not possible to describe in a deterministic way the outcome of the bidding decision. In addition, there were uncertainties involved with the success or failure of the

competing venture that had implications for the developing of the mining activity, with or without a partner. From the outset, therefore, we were confronted with the following uncertain parameters:

- Probability of winning the bids for land parcels, given specific bid values
- Probability of success of competing venture

The remaining uncertain parameters for our project were selected subjectively. The decision maker had no hesitation about pointing out those parameters whose uncertainties made it necessary that they be included in the analysis. The additional uncertain parameters were

- Magnitude of capital investments
- Product market price
- Operating costs

Notice that, of the parameters of our project listed in section 13.4.3, the following were considered to be deterministic:

- Plant capacity
- Tax rates
- Depreciation rates
- Fraction of capital investment subject to investment tax credit
- Inflation rates

Inflation was taken into consideration by expressing all costs and prices in terms of 1973 dollars.

13.4.8 CONSTRUCTION OF A DECISION TREE

After the uncertain parameters have been specified, it is useful to structure the investment problem by using a decision diagram or decision tree. The decision tree is a graphic representation of the interaction of decision variables with the uncertain parameters (or events). These interactions are presented sequentially through the time spanned by the planning horizon in the order in which decision variables are chosen by the decision maker and in which uncertain parameters become known to him. Simple introductions to formulating and solving decision trees are given by Hammond (1967) and Magee (1964a, b); comprehensive discussion of the subject is provided by Raiffa (1968) and Schlaifer (1969).

The decision tree of the investment problem is constructed in order to organize the elements of the problem clearly, to recognize and communicate the alternatives that are meaningful to the decision maker, and to program the remaining computations necessary to the analysis.

The decision tree for our project is shown in Figure 13.1. The initial decision node has four alternatives: bid for government property alone; bid with partner; stay with own property; and do not pursue or develop project. The bidding process is represented by nodes 2 through 5 (with a like set of nodes for bidding with partner). The bidding decision is represented by bid levels (high, medium, low) for parcel A (node 2) with a resolution of uncertainty associated with each (node 3). All bids are opened for public inspection, and, after this, new bids may be submitted for parcel B in a similar manner (nodes 4 and 5). Node 6 represents the outcome of the competing venture. If that venture is undertaken, the company only has sufficient resources to develop the mining project with a partner. If the competing venture is rejected, whatever partnership arrangement had been decided on would continue.

13.4.9 ASSESSMENT OF PROBABILITY DISTRIBUTIONS OF UNCERTAIN PARAMETERS

Once the parameters whose uncertainties are to be treated explicitly are determined, the next stage of our analysis consists of measuring the likelihood of occurrence of the possible outcomes of the uncertain parameters. This is accomplished by specifying the probability distributions of those parameters. If the parameters are independent of each other, each probability distribution can be determined separately. However, if the outcome of one parameter depends on the level of achievement of another parameter, we might have to assess conditional and marginal probability distributions. In these cases, characterizing the probability distribution of the uncertain parameters could be complex. For discussions of this subject see Schlaifer (1969, Chapters 8 and 9) and Winkler (1968).

In our project, because of the unique nature of the mining venture and the lack of previous experience with the parameters' behavior, we relied completely on subjective assessment to characterize the nature of the probability distributions of the uncertain parameters:

Probability Distribution of Winning Bids This distribution is given in Figure 13.2. It was assessed by determining the 1 percent, 25 percent, 50 percent, 75 percent, and 99 percent fractiles of the highest bid. The 1 percent fractile is \$5.5 million, indicating that the assessor believes that there is only one chance in a hundred that the highest bid for this particular parcel will be below \$5.5 million. All the uncertain parameters were assessed by means of this fractile technique.

Probability of Success of Competing Venture The probability of success was assessed at 0.1.

Magnitude of Capital Investment In order to incorporate uncertainties in the capital investment stream, we used a capital investment multiplying factor. This factor, whose distribution ranged from 0.6 to 2.0, was multiplied by the engineering estimates (base case) of the capital investments to yield the possible capital investment stream.

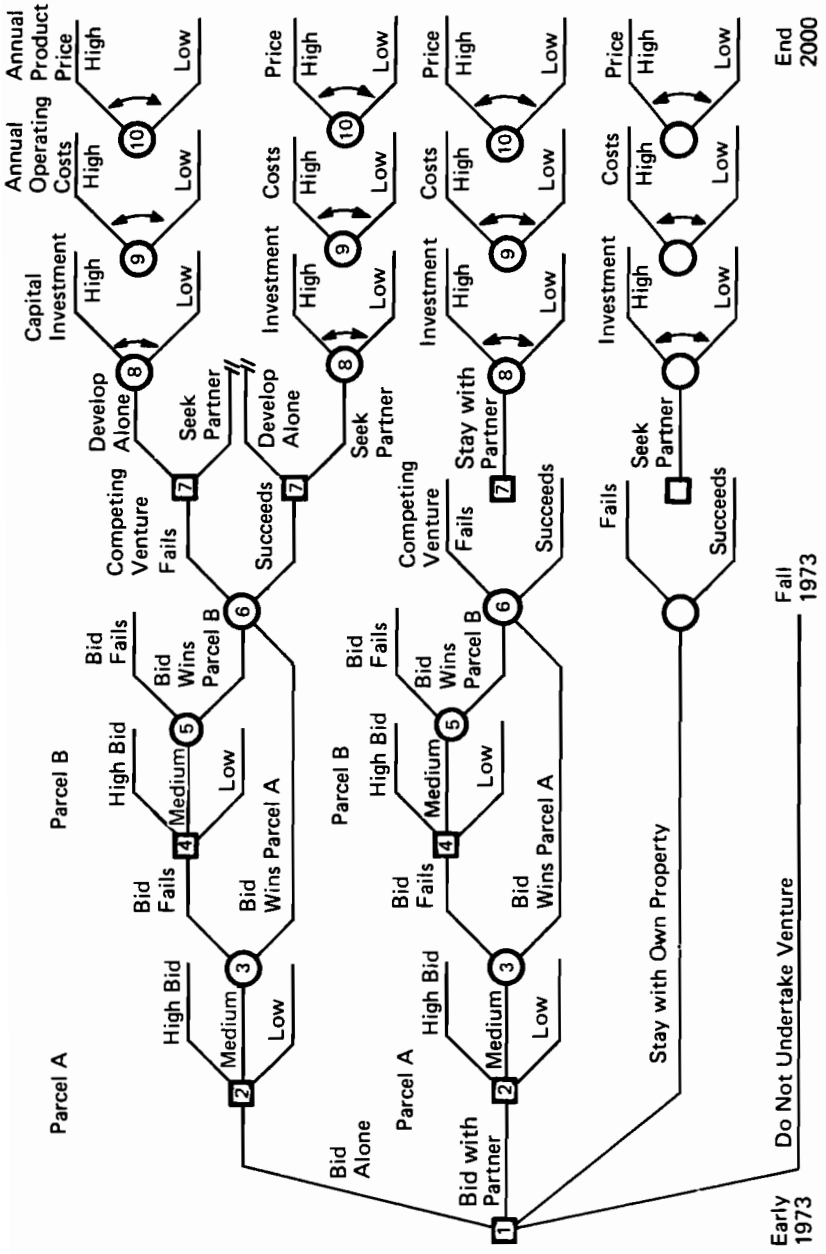

FIGURE 13.1 Decision tree for capital investment project. Circles represent uncertain events; squares, decision alternatives. Like nodes and branches are suppressed.

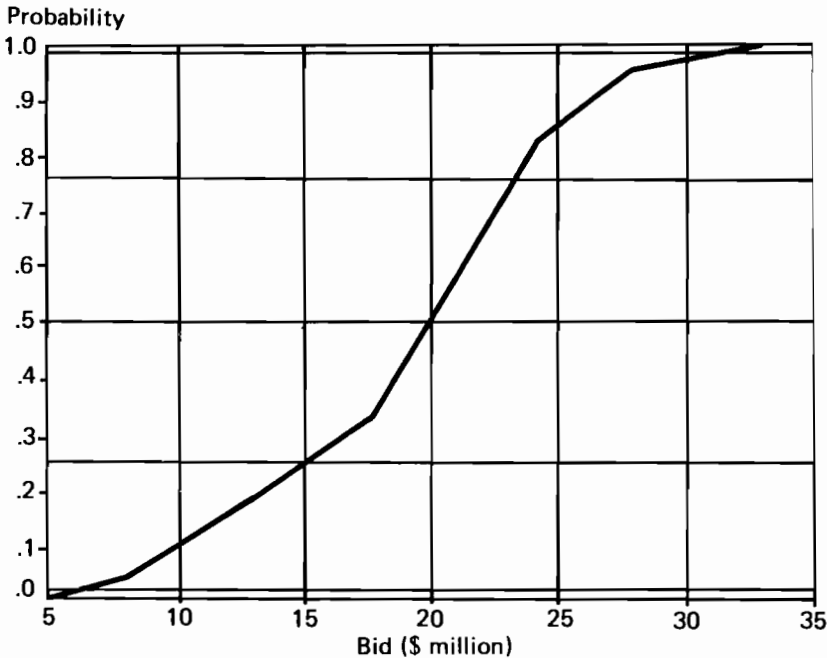

FIGURE 13.2 Probability of winning bids, encoded by decision maker at 1 percent, 25 percent, 50 percent, 75 percent, and 99 percent.

Product Market Prices Five market price distributions were assessed – for 1980, 1985, 1990, 1995, and 2000. Whenever we sample from these distributions, we draw a single random number (from 0 to 1.0) and obtain the corresponding prices for the 5 years indicated. Prices for intermediate years are interpolated. This approach was adopted in order to take into consideration the strong correlation between market prices for the various years. A more formal approach would have required assessing conditional probabilities of market prices in year n given a specific price in year $n - 1$. The computational effort required for such an assessment would have been prohibitively expensive.

Operating Costs The operating costs were represented by two distributions. First, an initial operating cost was assessed. Operating costs for the subsequent years were obtained by applying a growth factor, whose distribution ranged from 0.75 to 1.5, to this initial value.

13.4.10 DEFINITION OF RELEVANT STRATEGIES AND COMPUTATION OF RISK PROFILES

In our project, 26 strategies were defined. These strategies refer to the partnership conditions (bidding either alone or with a partner); the bidding level for each

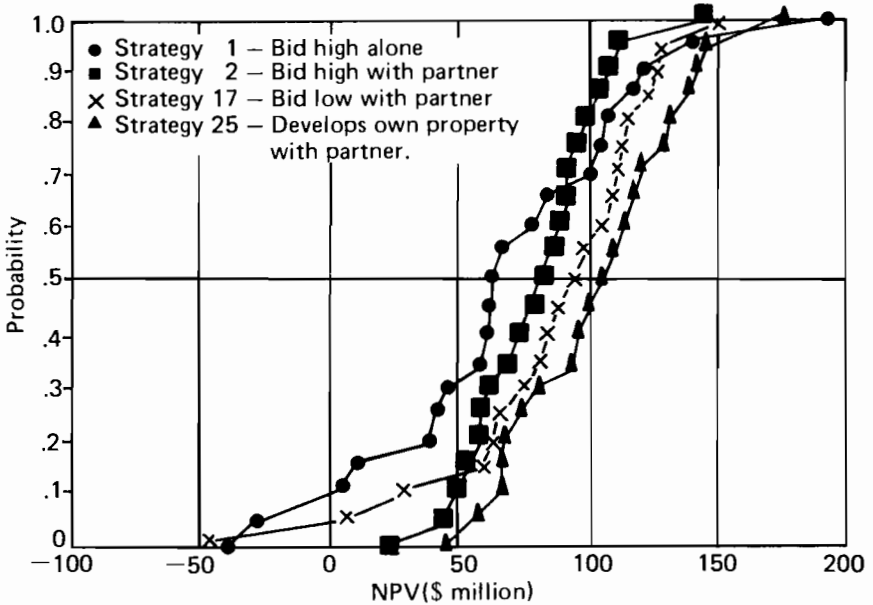

FIGURE 13.3 Risk profiles (in NPV) for four selected strategies. Mean NPV for strategy 1 was \$71 million; for strategy 2, \$81 million; for strategy 17, \$87 million; and for strategy 25, \$101 million.

parcel – high, medium, and low – if a bid is to be placed; or not bidding at all and developing already owned property.

It is not enough to measure the profitability of each strategy by the expected net present value since the uncertainty in the project makes it impossible to guarantee the achievement of a specified NPV. We need to include some measures of the variability of the NPV. It has become common practice to represent the performance of a project by providing the complete probability distribution of the selected measure of profitability. This distribution is known as the *risk profile* of the investment. Figure 13.3 provides the NPV risk profiles for four of the 26 strategies (strategies 1, 2, 17, and 25). These strategies stochastically dominated all other strategies. The NPVs were calculated for a discount rate of 10 percent. It can be seen from Figure 13.3 that strategy 25 dominated all other strategies except for a minor end-effect where strategy 1 becomes preferable.

13.4.11 TREATMENT OF RISK ATTITUDES FOR SINGLE-OBJECTIVE PROJECTS

Sometimes for projects with single objectives, the risk implications of each strategy can be resolved by carefully analyzing each strategy's risk profile. If a clear

dominance exists, as seems to be the case with strategy 25, the decision maker can feel confident enough to reach a decision at this stage of the investment analysis. In any event, the risk profiles could eliminate from further consideration a number of the strategies selected initially that are shown to be clearly dominated by a subset of superior strategies. If a clearly dominant strategy cannot be identified at this stage, it might be necessary to assess the attitude of the decision maker toward risks by eliciting his *utility function* (or *preference function*). A utility function provides a complete description of the decision maker's attitude toward risk over the range of all the possible consequences of the project under analysis.

Using the lottery technique discussed in Schlaifer (1969), the exponential utility function

$$U(\text{NPV}) = 1.3 (1 - e^{-.005(\text{NPV} + 100)})$$

was assessed for NPV scaled from 0 for -\$100 million to 1 for \$200 million. This utility function allows characterization of each strategy by a single number, its expected utility. The optimal strategy is then selected simply by choosing the strategy with the highest expected utility.

For our project, the four leading strategies and the do-nothing option had the following expected utilities and certainty equivalents:

	1 Bid High Alone	2 Bid High with Partner	17 Bid Low with Partner	25 Develop Own Property with Partner	26 Do Nothing
Expected risk utility	.704	.747	.750	.797	.512
Certainty equivalent (\$million NPV)	56	71	72	90	0

As was the case with the NPV risk profiles, strategy 25 is dominant. It is now also clear that strategies 2 and 17 are almost indistinguishable and strategy 1 is much worse than the other strategies.

13.4.12 OPTIMAL STRATEGIES WITH TWO OBJECTIVES

The steps described so far provide a complete and comprehensive analysis of capital investment decisions with a single objective. As indicated in section 13.4.6, the consequences of our project could not be properly evaluated by considering profitability measures alone. A second objective of great significance was the maximization of product output.

A highly simplified treatment of multiple-objective decisions can be performed by assigning a weight to each objective that reflects its importance to the decision maker. This approach will transform the multiple-objective analysis into a

single-objective problem. This procedure neither recognizes the nonlinear trade-offs that frequently exist among competing objectives nor considers interdependence among these objectives.

We will now proceed to apply to our problem a more formal treatment based on decision analysis and utility theory concepts. This stage of our project closely follows the approach of Keeney (1972) and Keeney and Raiffa (1976).

The two competing objectives, and their associated attributes (NPV and percentage of possible government parcel production rate), that the decision maker considered of importance in our decision situation were

Maximization of profit

Maximization of output

The ranges of the attributes were -100 to $+200$ for NPV and 0 to 100 for possible percentage of production (P). The single-objective utility function for NPV was established above in section 13.4.11 (for $P = 100$).

The next step was to establish the proper form of the two-objective utility function. By reassessment of the certainty equivalents of NPV at several values of P , and then by repeating the procedure for P at several values of NPV, it was concluded that the two objectives were utility-independent. A utility function of the following form was adopted:

$$\begin{aligned} U(\text{NPV}, P) &= U(\text{NPV}, P_0) + U(\text{NPV}_0, P) + kU(\text{NPV}, P_0) U(\text{NPV}_0, P) \\ &= a_1 U_1(\text{NPV}, P_0) + a_2 U_2(\text{NPV}_0, P) \\ &\quad + \frac{1 - a_1 - a_2}{a_1 a_2} a_1 U_1(\text{NPV}, P_0) a_2 U_2(\text{NPV}_0, P), \end{aligned}$$

where NPV_0 and P_0 are reference values of NPV and P ; $U_1(\text{NPV}, P_0)$ and $U_2(\text{NPV}_0, P)$ are the single-objective utility functions for NPV and P , respectively, and they are assessed at the reference value P_0 and NPV_0 ; and a_1 and a_2 are scaling constants.

The single-objective utility functions $U_1(\text{NPV})$ and $U_2(P)$ were fitted to first-order exponential functions. The assessment of the constants a_1 and a_2 was performed along the same lines as those described by Keeney (1972) and resulted in the function

$$\begin{aligned} U(\text{NPV}, P) &= 0.988 (1 - e^{-.005(\text{NPV}+100)}) + 0.197 (1 - e^{-.03P}) \\ &\quad + 0.067 (1 - e^{-.005(\text{NPV}+100)})(1 - e^{-.03P}). \end{aligned}$$

The corresponding utility surface is given in Figure 13.4, which also includes the basic gamble and the point of indifference used to determine the constants a_1 and a_2 in the utility functions. This utility surface reflects the willingness of the decision maker to trade off a reduction in NPV of about \$11 million in order to increase available production from 35 percent to 50 percent; this unwillingness was later corroborated by consistency checks.

Indifferent Point.
 $U(200, 0)$ indifferent to $U(55, 100)$
 Gamble:

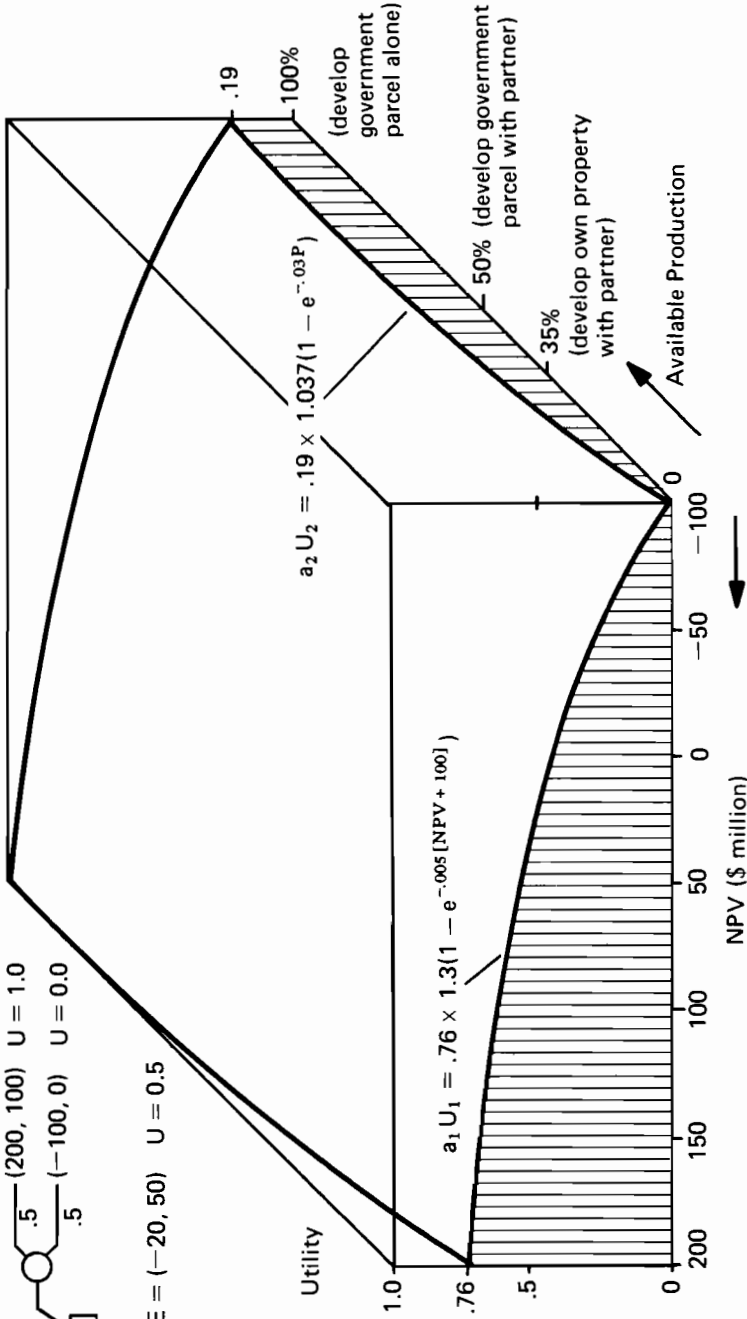

FIGURE 13.4 Multiattribute utility functions for NPV and production.

The expected utility for each strategy was calculated using Monte Carlo simulation by computing the utility for each trial from the NPV and available production and then converting these projections into expected utility values. To compute an illustrative certainty equivalent for each strategy that corresponds to the expected utility value obtained from the simulation, it is common practice to freeze one of the attributes at a specified reference point. By assessing the certainty equivalent at this arbitrarily specified value for one attribute (in our example, 50 percent of available production), the value of the other attribute that corresponds to the certainty equivalent can be determined. For our project, the four leading strategies and the do-nothing option had the following expected utilities and corresponding certainty equivalents:

	1 Bid High Alone	2 Bid High with Partner	17 Bid Low with Partner	25 Develop Own Property with Partner	26 Do Nothing
Expected two- objective utility	.719	.722	.706	.710	.386
Certainty equivalent (\$ million NPV) (assessed at $P = 50$)	51	52	45	47	—

Strategies 2 and 1 have the highest utilities and have now become the most desirable. According to the decision maker's preferences with regard to the two objectives, he should bid high on the government parcels with a partner. Almost the same utility is found for bidding high without a partner. These results contrast with the analysis of NPV or single-objective risk attitudes, where strategy 25 was found to be best (develop own parcel with partner and do not bid on government land). The utilities of all these strategies are about twice that of doing nothing.

13.5 CONCLUSIONS

In many capital investment projects there are several competing objectives to be considered if the optimal strategy is to be determined. For the project analyzed in this paper, the two-objective optimal strategy (strategy 2) was not found to be optimal when only the monetary objective was considered. The ranking of strategies by the three methods of analysis were (by direct ranking of strategies from Figure 13.3 and from the earlier tables of risk utility and two-objective utility scores):

	1 Bid High Alone	2 Bid High with Partner	17 Bid Low with Partner	25 Develop Own Property with Partner	26 Do Nothing
NPV analysis rank	4	3	2	1	5
NPV risk utility rank	4	3	2	1	5
Two-objective utility rank	2	1	4	3	5

It can be seen that the rankings change significantly when the second objective is brought in. The differences in terms of NPV between strategies 25 and 2 is \$20 million (25 is better), while the difference between the two strategies' certainty equivalents (in NPV) with two objectives is \$5 million (2 is better). If the certainty equivalents from the NPV analysis had been the basis for the decision, the wrong strategy would have been chosen. In addition, the value of the chosen strategy (25) would have been overestimated by \$25 million compared with the multiattribute optimal strategy (2). The changes in the certainty equivalents for the four strategies under the three analysis methods are shown in Figure 13.5.

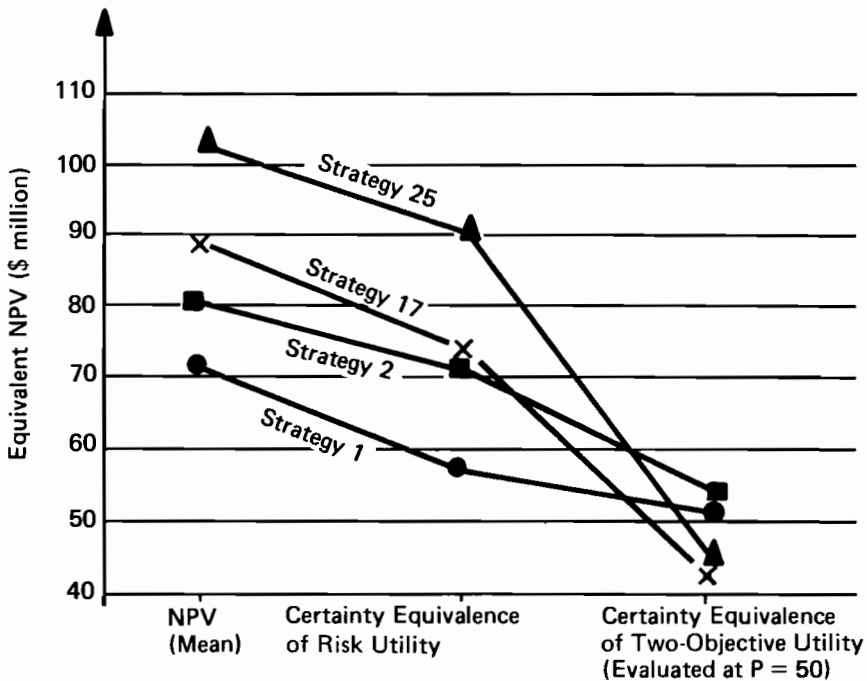

FIGURE 13.5 Change in certainty equivalent for four selected strategies with change in analysis method.

The decision maker chose to pursue strategy 2 as a result of the analysis outlined in this paper. He had been frustrated by his inability to handle the two objectives and resolve the trade-offs (or conflicts, as he expressed it). With the multiattribute utility analysis he was satisfied that his views and values were properly represented and, hence, he had no hesitation in accepting the optimal strategy. Minimization of scarcity of capital emerged as a third objective when the final results were presented to the decision maker, and if strategy 1 (bid alone) had been found to be best, it would have been necessary to include this objective in the analysis, since the decision maker would have placed a value on reducing capital outlays for the first 3 years through partnership until the firm had become strongly committed to the project.

REFERENCES

- Bierman, H., and S. Smidt. 1966. *The Capital Budgeting Decision*. Macmillan, New York.
- Hammond, J.S., III. 1967. Better decisions with preference theory. *Harvard Business Review*, Vol. 45, pp. 123-141.
- Hax, A.C., and K.M. Wiig. 1975. The use of decision analysis in capital investment problems. Technical Report No. 118. MIT Operations Research Center, Cambridge, Massachusetts.
- Howard, R.A. 1968a. Decision analysis: applied decision theory. In *Proceedings of the Fourth International Conference on Operational Research* (D.B. Hertz and J. Melere, eds.). John Wiley, New York.
- Howard, R.A. 1968b. The foundations of decision analysis. *IEEE Transactions on Systems Science and Cybernetics*, Vol. SSC-7.
- Keeney, R.L. 1972. An illustrative procedure for assessing multiattributed utility functions. *Sloan Management Review*, Vol. 14, pp. 37-50.
- Keeney, R.L., and H. Raiffa. 1976. *Decisions with Multiple Objectives*. John Wiley, New York.
- Magee, J.F. 1964a. Decision trees for decision making. *Harvard Business Review*, Vol. 42, pp. 126-138.
- Magee, J.F. 1964b. How to use decision trees in capital investment. *Harvard Business Review*, Vol. 42, pp. 79-96.
- Modigliani, F., and M.H. Miller. 1958. The cost of capital, corporation finance and the theory of investment. *American Economic Review*, Vol. 48.
- Raiffa, H. 1968. *Decision Analysis: Introductory Lectures on Choices under Uncertainty*. Addison-Wesley, Reading, Massachusetts.
- Schlaifer, R.O. 1969. *Analysis of Decisions under Uncertainty*. McGraw-Hill, New York.
- Simon, H.A. 1960. *The New Science of Management Decision*. Harper & Row, New York.
- Solomon, E. 1963. *The Theory of Financial Management*. Columbia University Press, New York.
- Spetzler, C.S., and R.M. Zamora. 1971. Decision Analysis of a Facilities Investment and Expansion Problem. Paper 172-187. Stanford Research Institute, Stanford, California.
- Winkler, R.L. 1968. The consensus of subjective probability distributions. *Management Science*, October, pp. B-61-B-75.

DISCUSSION

ZIONTS: Did you calculate the highest bid price that you could consider that still gave you a positive net present value? If so, was it significantly greater than the bid price calculated?

WIIG: It was not. We did not do the analysis *per se*, but we did some sensitivity analyses that indicated this.

MacCRIMMON: Did you do any sensitivity analyses using the two-objective utility function? Given your results, it might be that small changes in the parameters might lead to quite different rankings of the alternatives.

WIIG: We did a very small amount. Unfortunately, we were pressed for time on this project. This is one of the things that often happens with real decisions.

KULIKOWSKI: I have two questions. You have a strategy that you call "do nothing." Did you take into account the so-called forgone opportunities? As you mentioned, if the company didn't engage in the project, they could spend their money somewhere else. The next question is about the return on capital. Is this taken from the point of view of the company, or, in a broader sense, does it also include social considerations?

WIIG: First, I would say we did not adequately portray the "do nothing" strategy in terms of opportunity cost. We defined it essentially as just a zero net present value instead of looking at the expected return on investment for other opportunities. Secondly, we looked at the economics exclusively from the company's viewpoint.

MEYER: I do not understand the first part of your answer; presumably, the discount rate you used was precisely what you assessed the opportunity cost of invested funds to be. Philosophically, what meaning does that discount rate that you use have other than the return you could have made from that capital if used otherwise? If that is the meaning it had, then isn't the answer to the previous question, "Yes, we did take into account the return from other opportunities, and that is what our 'do nothing' is."

WIIG: If you have a large portfolio of opportunities to choose from, yes. I think if you were to do this analysis properly, you would have to look explicitly at the projects that you displace by committing funds, and this we did not look at at all. So in that sense we did not look properly at the forgone opportunities.

KEENEY: Were the utility assessments conducted with the president of the company? Also, what difficulties did you have in obtaining those, and what receptiveness or lack of it does he have toward using such procedures again?

WIIG: The utility assessments were the president's. I think he would be quite willing to do such assessments again if he were faced with a situation that required this kind of attention. He was very interested in participating in this "game," as he saw it. In other words, he thought very highly of the novelty of doing this aspect of the analysis in this particular way. We don't find this attitude in all situations that we encounter.

EDWARDS: What kind of feedback did you get from the discrepancy between predicted bid and actual bid?

WIIG: We did not provide the distribution of expected bids. Our client's staff provided that. The expected bid was approximately an order of magnitude less than the actual top bid. Our client's bid was also an order of magnitude under the top bid.

RAIFFA: As is often the case, probability distributions are assessed too tight. This has been demonstrated in practice as well as in the laboratory.

PESCHEL: How sure can you be that the last rank order that you got is a reliable one, since the differences between them are small?

WIIG: They *are* small. In this particular case, we did keep track of the dominance relationships among strategies for many possible scenarios. We found that our best strategy was very robust. I think this is something that we tend to avoid considering on specific occasions.

ROY: It is possible to split your strategies into two parts, the second following in 1 or 2 years?

WIIG: In this case we have perhaps four initial strategies, and after a couple of months you have to branch some of these four into several other strategies.

ROY: How do you take into account the fact that after 6 months you will perhaps get some new information concerning the uncertainties that you have initially? Do you adapt the first decision to account for this information?

RAIFFA: This question could arise in general. Certainly, decision analysis incorporates any consideration of the way uncertainties unfold in time, as well as reactions later on. Thus, if the tree were an accurate representation of what could happen, then the analysis adequately considers these factors. If the purpose of your question goes deeper, implying that the decision tree is never really complete, then there would be uncertainties that would unfold in the future that are not even contemplated on the tree. In this case, the analysis is incomplete, and one would have to make adjustments for that lack of completeness. All these considerations are closely tied to the difficulties of problem definition.

MEYER: My point relates directly to that question. Just to play devil's advocate, I am going to suggest that this decision analysis did the opposite of what you want a decision analysis to do – namely, it prevented discussion about the real strategic issues in the problem. Now I need a lot of suppositions in this case in order to achieve my point. You got a very narrow distribution of future crude prices, of bids by others, and so on. That's not unusual. You had excluded from consideration a scenario that was an improbable one, namely the Middle East war. Everything was done to give you assessments that are too narrow. Then, for no reason that I can see other than to make the calculation come out with the desired answer, you brought in another variable for which we have utility, apart from the monetary factor. This was the notion of how much additional crude supply we can acquire.

Now I suggest that the strategic questions for an oil company are indeed whether they want to be crude rich, in what part of the world they wanted their crude resources to be; whether they want their primary contribution to be refining and distribution activity, or whether they want to be the owner of crude reserves, charging high economic rents for mineral sources. The question for analysis is how the strategic questions facing this oil company should be included in the problem. You included them by putting in the amount of crude supply obtained as an additional variable. What I am suggesting is that because you wanted to keep the

calculations rather simple and limited, the real strategic issues that decision analysis is supposed to address here were not addressed. Now, I have obviously made an extreme case, and I make it only so that, if there is going to be debate on this sort of question, you have something to punch against.

WIIG: I think you have raised a very relevant question, and I think it's one that might be quite typical for applications of decision analysis by people like me and by companies like ours. Indeed, it is very, very difficult for us to change the scope of the analysis. We are faced with situations that have a predetermined scope, and we are not allowed to go outside that scope. This particular analysis, although it was done for an oil company, was done at a time when all companies considered that the world would go on in the future as it had in the past. They did not worry about drastic changes in supply. I think that the decision maker in this case was concerned about it, but the company itself (i.e., the board of directors) was not concerned about it and did not want to discuss it.

MEYER: I have some knowledge of the activities of another oil company during the period your decision was considered. This company had a group of people developing scenarios and had already forecast enormous uncertainties in oil prices. They had a scenario for the kind of thing that happened. It is a fascinating question to decide how much impact you have by structuring the problem and by fitting objective functions and by doing all those things. In fact, you might have much more impact by just stimulating somewhat broader thought that might result in much broader distributions.

RAIFFA: This is a question that comes out in all kinds of quantitative analysis. Very often, hard analysis drives out the softer strategic planning aspects. In my experience, I can give examples where the analysis was so constrained that it left out the strategic considerations. In other examples, the analysis forced the articulation of strategic issues that were lying linked but unrecognized in the decision maker's mind.

14 Selecting Nuclear Power Plant Sites in the Pacific Northwest Using Decision Analysis

Ralph L. Keeney and Keshavan Nair

The Washington Public Power Supply System (WPPSS) is a joint operating agency consisting of 21 publicly owned utilities in the State of Washington. In 1974, WPPSS authorized a study by Woodward–Clyde Consultants to identify and recommend potential new sites in the Pacific Northwest suitable for thermal electric power generating stations with a nominal capacity of 3000 MWe that might be required after 1984. The study was to be conducted on the basis of existing information and field reconnaissance; no detailed site-specific studies were to be made. The objective of the study was to recommend sites that would have a high likelihood for successful licensing and that therefore would be most suitable for the detailed site-specific studies necessary for final selection of a single nuclear power plant site. The approach (Nair *et al.*, 1975) used to conduct this study consisted of two major steps:

A screening process to identify the candidate sites

A decision analysis to evaluate and rank the candidate sites

Details of the overall study process are described in Woodward–Clyde Consultants (1975).

This paper focuses on evaluation of the candidate sites. To indicate how those sites were identified, the screening process is summarized in section 14.1. Section 14.2 describes the objectives and the attributes used to evaluate the candidate sites. The assessment of the utility function is presented in section 14.3, and probability assessments describing the possible impacts associated with each site are given in section 14.4. Section 14.5 presents the evaluation of sites using the information developed and the sensitivity analysis. The final section contains our conclusions and recommendations.

14.1 THE SCREENING PROCESS: IDENTIFYING THE ALTERNATIVES

The study area consisted of approximately 170,000 square miles, including the entire State of Washington, the major river basins in Oregon and Idaho that are tributary to rivers in Washington, and the major river basins of the Oregon coast. The study was directed toward finding new sites, and therefore all areas within a 10-mile radius of the U.S. Energy Research and Development Agency's Hanford reservation and other site areas for which electric generating facilities have been formally proposed or are under development were excluded. It is clearly impractical to evaluate every possible site in such a large area. Financial and time constraints require that one concentrate on areas where the likelihood of finding candidate sites is high.

The first step in the screening process involved establishing the basis for selecting sites. An extensive hierarchy of issues and considerations pertaining to thermal power plant siting was developed. The issues concerned safety, environmental, social, and economic considerations. Criteria defining a required level of achievement on each consideration were established to identify areas for further evaluation. Examples of these specific criteria are given in Table 14.1.

Some of the criteria for inclusion result from the rules of regulatory agencies – e.g., distance from a capable fault or proximity to a protected ecological reserve. Other considerations are functional – e.g., the accessibility of an adequate supply of cooling water. There are also considerations related to cost, for which the project team, in consultation with representatives of WPPSS, established minimum levels of achievement – e.g., the ruggedness of the terrain and distance from railroads and waterways. In addition, considerations relating to public opinion and priorities were included. Examples of such considerations are exclusions of areas of scenic beauty or unusual ecological character that have not been designated as legally protected areas.

Once screening criteria were specified, those parts of the study area where a criterion was satisfied were identified and plotted on an appropriate map. Overlay techniques were used to produce composite maps that specified areas meeting all the criteria. A field reconnaissance team of experienced engineers, geologists, and environmental scientists visited these areas. Using their observations as well as published information, these experts identified nine candidate sites for further consideration. The subsequent evaluation of these sites using decision analysis is the main topic of this paper.

Before we proceed, an important remark concerning the screening process is in order. A big assumption is made implicitly when we include or exclude areas merely because they fall just under or over a cutoff level on *one* criterion. In reality, there is no sharp distinction, and utilizing this approach may eliminate potential areas that are fine on several criteria but just barely fail on one or two. However, such an approach provides a mechanism of rapidly focusing attention on candidate areas that have higher probabilities of containing acceptable potential sites. We consider

TABLE 14.1 Examples of Criteria Used in Screening Process

Issue	Consideration	Measure	Criteria for Inclusion
Health and safety	Radiation exposure	Distance from populated areas	Areas > 3 mi from populated places > 2,500 Areas > 1 mi from populated places < 2,500
	Flooding	Height above nearest water source	Area must be above primary floodplain
	Surface faulting	Distance from fault	Areas > 5 mi from capable or unclassified faults > 12 mi long
Environmental effects	Thermal pollution	Average low flood	Rivers or reservoirs yielding 7-day-average, 10-year-frequency low flow > 50 ft ³ /sec
	Sensitive or protected environments	Location with respect to ecological areas	Areas outside designated protected ecological areas
Socioeconomic effects	Tourism and recreation	Location with respect to designated scenic and recreational areas	Areas outside of designated scenic and recreational areas
System cost and reliability	Routine and emergency water supply and source characteristics	Cost of cooling water acquisition	Rivers or reservoirs yielding 7-day-average, 10-year-frequency low flow > 50 ft ³ /sec
		Cost of pumping water	Areas < 10 mi from water supply Areas < 800 ft above water supply
	Delivery of major plant components	Cost of providing access for major plant components	Areas within 25 mi of navigable waterways

that the advantages (particularly in terms of time) of applying screening criteria override the disadvantage of possibly disregarding some candidate areas.

Another point to keep in mind is that screening criteria may change with time; they depend on social, political, technological, and financial conditions. Future siting efforts may need to use different or additional criteria as conditions change.

14.2 ESTABLISHING THE OBJECTIVES AND MEASURES OF EFFECTIVENESS

To help in identifying those characteristics that would differentiate the appropriateness of locating a nuclear power facility at one site instead of another, detailed descriptions of the sites were developed. The information gathered included the area, location, present use, and ownership of the site; the quality and quantity and location of the water supply; details of the natural factors, including geology, topography, flooding potential, and volcanic considerations; population in the vicinity; vegetation and wildlife, including fish, in the area; access to various transportation modes for construction and operation of the facility; existence of a local work force and catalog of potential socioeconomic effects of the construction phase; and so on. By means of this information, plus data gathered during the screening process, approximately 30 potential objectives with associated attributes for evaluating these particular sites were identified.

It was unlikely that each of these would be significant in the evaluation process. Hence, each one was qualitatively examined (and in some cases, quantitatively examined in a preliminary manner) to determine the reasonableness of keeping it in the evaluation process. Three general concepts were used for this examination:

- The significance of the impact in terms of an attribute in relation to impacts as measured by other attributes. For example, the annualized capital cost of a nuclear power plant is in the range of \$200–300 million for the candidate sites, and the annual revenue loss from adverse effects of plant operation on fish is in the range of \$0–500,000. Under these conditions, the contribution of the latter to the relative preferences of the sites could be neglected.
- The site-dependent variation of the impact in terms of an attribute. For instance, even though yearly manpower costs for plant operation may be significant, they might be omitted from consideration if these costs are nearly identical for all sites.
- The likelihood of occurrence of significant impacts as measured by an attribute. If one combines the magnitude of impact with the likelihood of its occurrence, the resulting “weighted” impact can be relatively insignificant. Consider, for example, adverse effects on crops that could amount to as much as \$9 million per year. However, considering the near-zero probabilities of such extreme losses, the “weighted” impact is in thousands of dollars rather than in millions of dollars. Such an impact is considered insignificant.

TABLE 14.2 Attributes and Ranges Used in Evaluating the Candidate Sites

Issue	Attribute	Range	
		Worst	Best
Health and safety	$X_1 \equiv$ site population factor	0.20	0
Environmental effects	$X_2 \equiv$ loss of salmonids	100% of 100,000 fish	0
	$X_3 \equiv$ biological impacts at site	(Subjective scale described in Table 14.3)	
	$X_5 \equiv$ length of intertie to 500-kV system through environmentally sensitive areas	50 mi	0
Socioeconomic effects	$X_4 \equiv$ socioeconomic impact	(Subjective scale described in Table 14.4)	
System cost	$X_6 \equiv$ annual differential cost between sites – 1985 dollars, 30-yr plant life	\$40,000,000	0

The examination of possible objectives was evolutionary in nature. Preliminary estimates were made of possible impacts and their probabilities. Using these, some objectives were disregarded. Estimates of the remaining impacts were updated on the basis of field visits, and a few more objectives were discarded. As a result of this process, the list of attributes in Table 14.2 was generated for evaluating candidate sites. For each of the attributes, a measurement index was established and ranges of possible impact determined.

14.2.1 CLARIFYING THE ATTRIBUTES

Attribute X_1 , the site population factor, is an index developed by the U.S. Atomic Energy Commission to indicate the relative human radiational hazard associated with a nuclear facility. The site population factor at a location L, denoted $SPF(L)$, is defined by

$$SPF(L) = \frac{\sum_{r=1}^{50} P(r)r^{-2}}{\sum_{r=1}^{50} Q(r)r^{-2}}, \quad (14.1)$$

where r is miles from site L, $P(r)$ is the population living between $r-1$ and r miles of L, and $Q(r)$ is the population that would live between $r-1$ and r miles of L if there were a uniform density of 1,000 people per square mile. The r^{-2} is meant to account for the decrease in radiation exposure hazard with distance. The purpose of the denominator in (14.1) is to allow one to intercept an $SPF = 0.1$, for example, as equivalent to a uniform distribution of 100 (i.e., 0.1 times 1,000) people per square mile within 50 miles of the site.

TABLE 14.3 Subjective Scale for Biological Impacts (Attribute X_3)^a

Scale Value	Level of Impact
0	Complete loss of 1.0 mi ² of land that is entirely in agricultural use or is entirely urbanized; no loss of any "native" biological communities.
1	Complete loss of 1.0 mi ² of primarily (75%) agricultural habitat with loss of 25% of second growth; no measurable loss of wetlands or endangered-species habitat.
2	Complete loss of 1.0 mi ² of land that is 50% farmed and 50% disturbed in some other way (e.g., logged or new second growth); no measurable loss of wetlands or endangered-species habitat.
3	Complete loss of 1.0 mi ² of recently disturbed (e.g., logged, plowed) habitat, plus disturbance to surrounding previously disturbed habitat within 1.0 mi of site border; or 15% loss of wetlands or endangered-species habitat.
4	Complete loss of 1.0 mi ² of land that is 50% farmed (or otherwise disturbed) and 50% mature second growth or other community; 15% loss of wetlands or endangered-species habitat.
5	Complete loss of 1.0 mi ² of land that is primarily (75%) undisturbed mature "desert" community; or 15% loss of wetlands or endangered-species habitat.
6	Complete loss of 1.0 mi ² of mature, second-growth (but not virgin) forest community; or 50% loss of big game and upland game birds; or 50% loss of local wetlands and local endangered-species habitat.
7	Complete loss of 1.0 mi ² of mature community or 90% loss of local productive wetlands and local endangered-species habitat.
8	Complete loss of 1.0 mi ² of mature, virgin forest or local wetlands or local endangered-species habitat.

^a This is a qualitative scale of potential short- and long-term impacts (excluding the impact on salmonids) that could result from the construction and operation of a power plant on a site. The impacts range from "0" for no impact to "8" for maximum impact. Site visits and general reconnaissance showed that the biologically important characteristics (aside from aquatic resources) of the regions are:

- Virgin or large, mature, second-growth stands of timber or "undisturbed" sagebrush communities
- Known or potential habitat of endangered species
- Wetland areas (though most are small and are comprised of small swamps)

Two separate indices were required to measure the salmonid impact adequately — the percent of fish lost in a stream and the number of fish in the stream. The reason for using these two measures, rather than simply using the number of fish lost, is that the salmonid population in each stream is distinct. Therefore, the loss of 2,000 fish in a stream of 2,000 is a greater loss than 2,000 fish in a stream of 50,000. For the Columbia River (over 350,000 salmonid), only the number lost is important because it is virtually impossible that a large percentage of these fish will be affected by a specific nuclear power plant and also because most of the fish in the Columbia are native to its tributaries.

Because attributes X_3 and X_4 were meant to capture many detailed possible impacts, it was necessary to develop subjective indices for each of them. The subjective index for biological impacts shown in Table 14.3 was developed by two experienced ecologists. Three main features captured by this scale are native timber or sagebrush communities, habitats of rare or endangered species, and productive wetlands.

The subjective index for socioeconomic impact, attribute X_4 , was constructed by a sociologist/planner (Table 14.4). The scale includes the implications for the public debt, social and cultural institutions, municipal services, and local authority due to the construction and operation of the nuclear facility. The purpose of such a scale is to identify a number of impact levels that are clearly articulated. In evaluating any specific site, one states the likelihood that the true impact will be between any particular adjacent pair of impact levels defined in Table 14.4.

The length of the transmission intertie line running through environmentally sensitive areas is measured in miles by attribute X_5 . Attribute X_6 is the annual differential cost between sites in terms of 1985 dollars, assuming a 30-year plant life. The discount rate used was 8.4 percent. Costs such as the major plant components are not included in attribute X_6 , since these would be the same for all sites. The differential is calculated relative to the lowest-cost site, for which the "differential cost" is set at zero.

14.3 DETERMINING THE PREFERENCE STRUCTURE

The position taken in determining the preference structure was that Woodward–Clyde Consultants would act as the decision maker for WPPSS. Other points of view were considered by conducting sensitivity analyses. It was decided that the utility function for each attribute would be assessed for the most knowledgeable members of the team (the "experts"). The trade-off constants would be jointly assessed by key members of the project team on the basis of their perception of the WPPSS point of view.

The process of determining the utility function can be broken down into four steps:

- Determining the general preference structure
- Assessing the single-attribute utility functions
- Evaluating the scaling constants
- Specifying the utility function

Before illustrating our procedure, let us define x_i to be a specific amount of attribute X_i , $i = 1, 2, \dots, 6$, so, for instance, x_6 may be \$8 million, a specific amount of the differential cost attribute x_6 . We want to determine the utility function $u(x_1, x_2, \dots, x_6)$ over the six attributes of Table 14.2.

TABLE 14.4 Subjective Scale for Socioeconomic Impact (Attribute X_4)

Scale Value	Level of Impact
0	Metropolitan region, population 100,000. No significant impact.
1	Semiremote town, population 250. Self-contained company town is built at the site. As many as half of the plant construction force continue to commute from other areas. Some permanent operating personnel continue to commute. Cultural institutions are overloaded, very little change in the social order. Public debt outstrips revenues by less than 6 months over previous levels.
2	Remote town, population 250. Self-contained company town is built at the site. Most of the work force moves into company town. Most permanent operating personnel begin to assimilate into the community. Cultural institutions are impacted, significant changes take place in the social order. Growth of the tax base due to permanent operating personnel is orderly, but public debt outstrips revenues by more than 6 months, less than 1 year, over previous levels.
3	Semiremote city, population 25,000. About half of the plant construction force immigrates and seeks housing in the city. Most of new growth is in mobile homes. All city systems (law enforcement, sewer, water, schools, code enforcement) are taxed to the limit. Outside financial assistance is required. Cultural institutions are impacted, social order is slightly altered. Permanent operating personnel easily assimilate into community, tax base grows significantly, but lags in assessment, planning, and capital improvements construction produce a boom-town atmosphere. Public debt outstrips revenue growth by 1–2 years.
4	Remote city, population 25,000. Most workers locate in the city. All city systems are impacted. Land-use patterns are permanently disrupted. Growth outstrips planning activities and regulatory systems. Assessment falls behind. Revenue–debt lag is greater than 2 years.
5	Semiremote town, population 1,500. Many workers commute from outside areas. Permanent operating personnel and some workers seek housing in the city. New growth is predominantly mobile homes, with much permanent construction as well. New construction in service establishments and expansion of commercial facilities. Town has basic planning and land-use regulatory functions established, but these are overwhelmed by magnitude of growth. Assessment and enforcement lag 2 years or more; community facilities are impacted. Land-use patterns are permanently disrupted. Cultural institutions are severely impacted; social order is permanently altered. Much growth occurs in unincorporated areas, untaxable by town.
6	Remote town, population 1,500. Most workers try to locate in or near the town. Most growth is in unincorporated areas. City systems are impacted; lack of regulation in unincorporated areas impacts rural development patterns, which in turn severely impacts the cultural institutions and social order. Tax base cannot expand to meet demand for capital improvements.
7	Remote city, population 10,000. Severe impact due to attractiveness to large numbers of plant workers. Basic services and established planning, assessment, and enforcement procedures are sufficient to provide the framework for rapid growth but insufficient to handle the magnitude of such growth. Massive imbalances in long-term city finances occur, leading to revenue–debt lags of several years. City size and bonding experience probably do not permit revenue financing, so the “bust” portion of the cycle is virtually inescapable.

14.3.1 DETERMINING THE GENERAL PREFERENCE STRUCTURE

The first important step in selecting the form of the utility function involves investigating the reasonableness of preferential independence and utility independence conditions (Keeney and Raiffa, 1976). Provided certain of these conditions are appropriate, the six-attribute utility function is expressible in a simple functional form of the six one-attribute utility functions. Let us illustrate the way one checks for such conditions.

Two attributes $\{X_i, X_j\}$ are *preferentially independent* of the other attributes if the preference order for (x_i, x_j) combinations does not depend on fixed levels of the other attributes. Consider differential cost X_6 and impact on salmonids X_2 . We first asked ourselves what level of X_6 would make $(x_6, 100$ percent of 100,000 salmon lost) indifferent to $(40$ million, 0 percent), given that the other four attributes were at their best levels. The answer obtained was 20 million. We then examined the same question with the other attributes at their worst levels. We still felt an appropriate response for x_6 was 20 million. By considering other pairs of indifferent points, we established that the trade-offs between $\{X_6, X_2\}$ would be independent of the level of the other attributes. Since the project team had been exposed to concepts of preferential and utility independence, they were in a position to state, after an initial series of questions of the above type over the attributes, that in general the trade-offs between any two attributes did not depend on the levels of the other attributes. Thus, each pair of attributes was considered preferentially independent of the others.

Attribute X_i is defined to be *utility independent* of the other attributes if the preference order for lotteries on X_i does not depend on fixed levels of the other attributes. This implies that the conditional utility functions over X_i are the same regardless of the levels of the other attributes.

To establish whether X_3 (biological impact) was utility independent of the other attributes, we assessed the conditional utility function for X_3 , assuming the other attributes are at fixed levels. We then reassessed the conditional utility function with the other attributes fixed at different levels. The assessment was conducted using the techniques described in the subsequent section. It was decided that the relative preference for lotteries involving uncertainty only in the consequences for X_3 did not depend on the other attributes. Thus, attribute X_3 was utility independent of the other attributes.

The above independence conditions implied that the multiattribute utility function u is either of the additive form

$$u(x) = \sum_{i=1}^6 k_i u_i(x_i), \quad (14.2)$$

or of the multiplicative form

$$1 + ku(x) = \prod_{i=1}^6 [1 + k_i u_i(x_i)], \quad (14.3)$$

where u is scaled 0 to 1 and the u_i are single-attribute utility functions scaled from 0 to 1, the k_i 's are scaling constants with $0 < k_i < 1$, and $k > -1$ is a scaling constant determined from the k_i 's.

A proof of this and suggestions for assessment are found in Keeney (1974). For reference, the multiplicative utility function turned out to be the appropriate one for this study, as we will later show. Although only one utility independence assumption is necessary to invoke either (14.2) or (14.3), this condition was verified for all the other attributes as a consistency check.

14.3.2 ASSESSING THE SINGLE-ATTRIBUTE UTILITY FUNCTIONS

The assessment of the utility functions with objective indices – that is u_1 , u_2 , u_5 , and u_6 – was done using the standard 50–50 lottery technique discussed in Keeney and Raiffa (1976). For instance, by considering preferences between a series of specified levels of X_6 and a 50–50 lottery yielding either a \$0 or \$40 million differential cost, each with probability 0.5, it was decided that WPPSS would be indifferent for a specified level of \$22 million. Thus, since utility is a measure of preference, the lottery and \$22 million must have equal expected utilities. Consistent with (14.3), we set the origin and scale of u_6 by letting the utility of the worst point 40 (see Table 14.2) equal zero and the utility of the best point 0 equal 1. Equating expected utilities leads us to $u_6(22) = 0.5$, which gives us another point on the utility curve. From this, the exponential utility function shown in Figure 14.1 H was evaluated. By examining the implications of this utility function for additional choice situations, it was decided that it was appropriate for evaluating the various sites.

For the subjective scales, a modified assessment technique was required. In order to achieve meaningful utility assessments for these attributes, only the defined points on the scales were used. For instance, with biological impact, the biologist member of the team was asked, “For what probability p is a biological impact of magnitude 4 (see Table 14.3) equivalent to a lottery yielding a p chance at level 0 and a $(1 - p)$ chance at level 8?” By trying several values of p , we found $p = 0.6$ to be the indifference value. Consistent with (14.3), we set $u_3(0) = 1$ and $u_3(8) = 0$, from which it followed that $u_3(4) = 0.6$. Questioning continued in this manner until the utility of each of the defined points on the subjective scale was fixed. A number of consistency checks were used, which resulted in some changes in the original assessments.

The adjusted utility functions assessed for each attribute are shown in Figure 14.1. Details of the assessment of the utility functions u_2 and u_3 are given in Keeney and Robilliard (1976). The assessment of u_2 was particularly interesting because of the two separate measures – the numbers and the percentage lost – required to describe adequately the possible impact on salmonids. Let us define Y as the number of salmonids in a stream in thousands and Z as the percent lost. Attribute X_2 is then a composite of Y and Z , so we will define $x_2 \equiv (y, z)$. If a

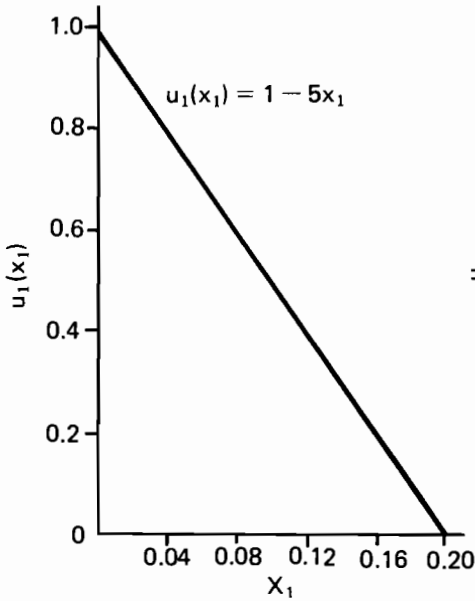

(A) SITE POPULATION FACTOR

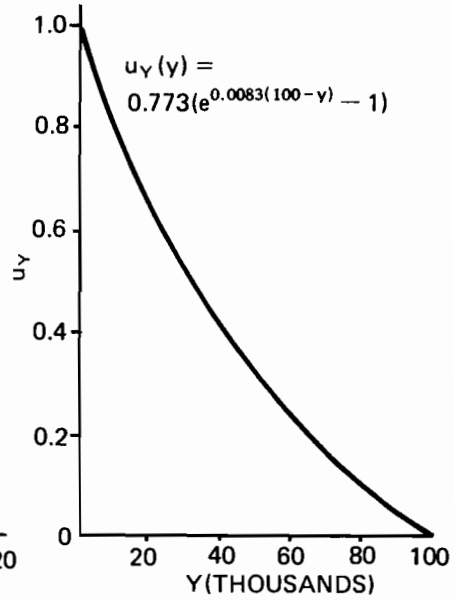

(B) NUMBER OF SALMONIDS IN STREAM

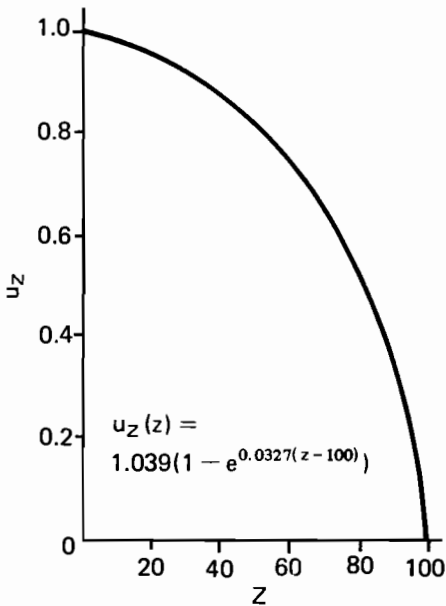

(C) PERCENT LOSS OF SALMONIDS

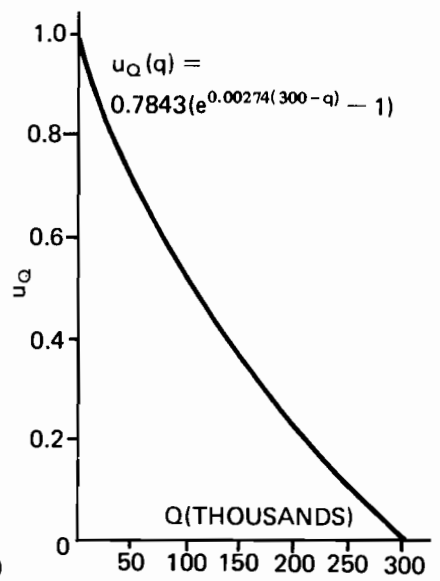

(D) NUMBER OF SALMONIDS LOST IN COLUMBIA RIVER

FIGURE 14.1 The single-attribute utility functions.

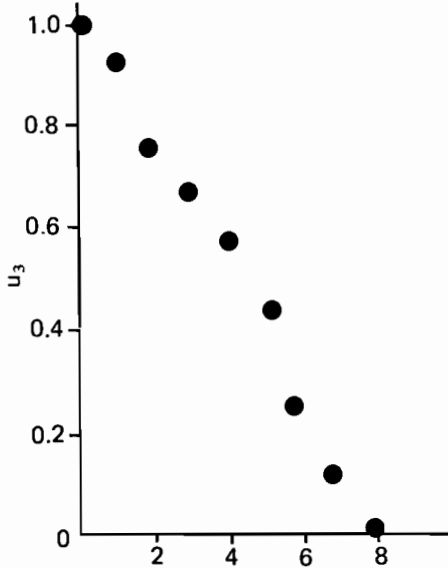

X_3 (INDEX OF BIOLOGICAL IMPACT)
(E) BIOLOGICAL IMPACT AT SITE

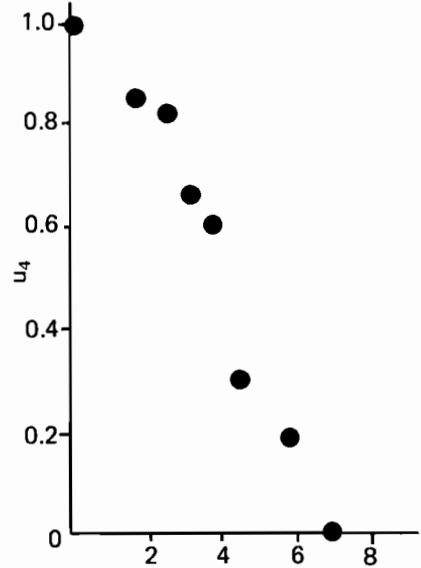

X_4 (INDEX OF SOCIOECONOMIC IMPACT)
(F) SOCIOECONOMIC IMPACT

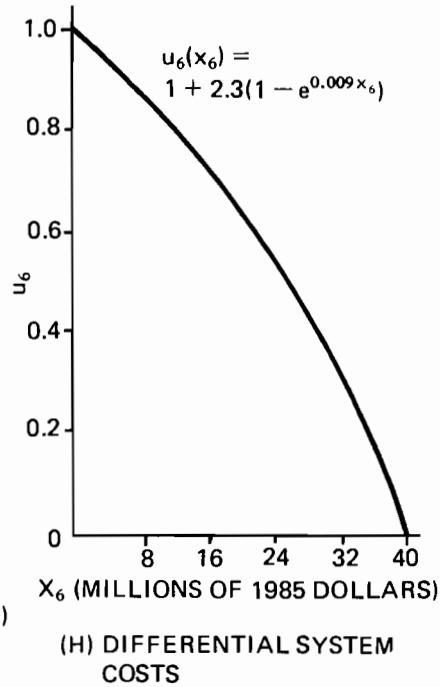
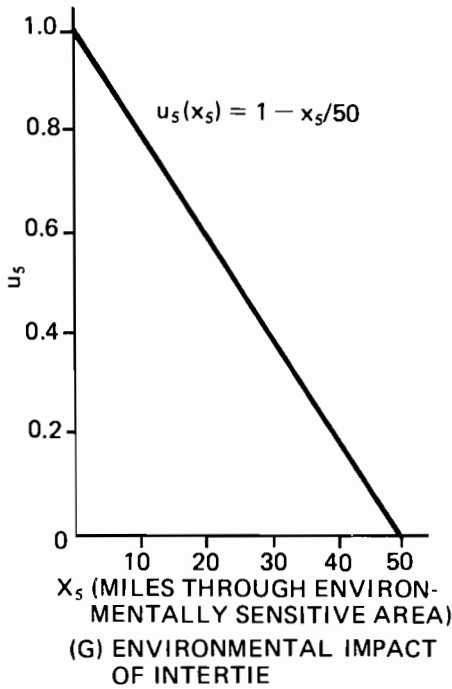

stream has less than 100,000 salmonids, a utility function u_2 was found to be

$$u_2(x_2) \equiv u_2(y, z) = u_Z(z) + u_Y(y) - u_Z(z)u_Y(y), 0 \leq y \leq 100,$$

where u_Y and u_Z are as illustrated in Figure 14.1B and C. For streams with greater than 300,000 salmonids, an appropriate utility function was

$$u_2(x_2) \equiv u_2(y, z) = 0.568 + 0.432 u_Q(q), y \geq 300,$$

where Q , defined as the number of salmonids lost, is Y times Z , and u_Q is as shown in Figure 14.1D. There are no streams with between 100,000 and 300,000 salmonids in the areas involved in our study, so the discontinuity in u_2 between $y = 100$ and $y = 300$ is not a difficulty.

14.3.3 EVALUATING THE SCALING CONSTANTS

The scaling constants were assessed by five members of the project team in two steps. The first consists of ranking the ranges of attributes in order of importance, and the second involves quantifying the magnitude of each k_i .

To establish the ranking of the k_i 's, the first question asked was: "Given that all six attributes are at their worst level as defined in Table 14.2, which attribute would you most like to have at its best level, assuming that the other five attributes remain at their worst levels?" The answer was X_6 , annual differential site cost, which implies that k_6 should be the largest scaling constant. (It should be noted that if the worst value of the differential site cost had been less than \$40 million, some other attribute might have been first.)

The order in which the remaining attributes were moved from their worst to their best levels was X_1 , X_2 , X_4 , X_5 , and X_3 . This ordering implies

$$k_6 > k_1 > k_2 > k_4 > k_5 > k_3. \quad (14.4)$$

The next step was to establish the actual values of scaling constants. This was accomplished by assessing specific trade-offs between attributes. For example, the trade-off between attributes X_6 and X_1 was established by answering the following question: "Consider a site B with a SPF = 0.2 and unspecified annual differential site cost. At what value of annual differential site cost would you be indifferent in choosing between site B and site A, which has an annual differential site cost of \$40 million and a SPF = 0, given that all other attributes are fixed at identical levels for both sites?"

The project team's response was that if site B had an annual differential site cost of \$5 million, it would be indifferent to site A. This implies that the project team was willing to incur an increase in annual differential site cost from \$5 to \$40 million in order to move a site from a sparsely populated area (SPF = 0.20) to an uninhabited area (SPF = 0). This assessed trade-off is represented graphically in Figure 14.2A. The trade-offs assessed for the other pairs of attributes are also shown in Figure 14.2.

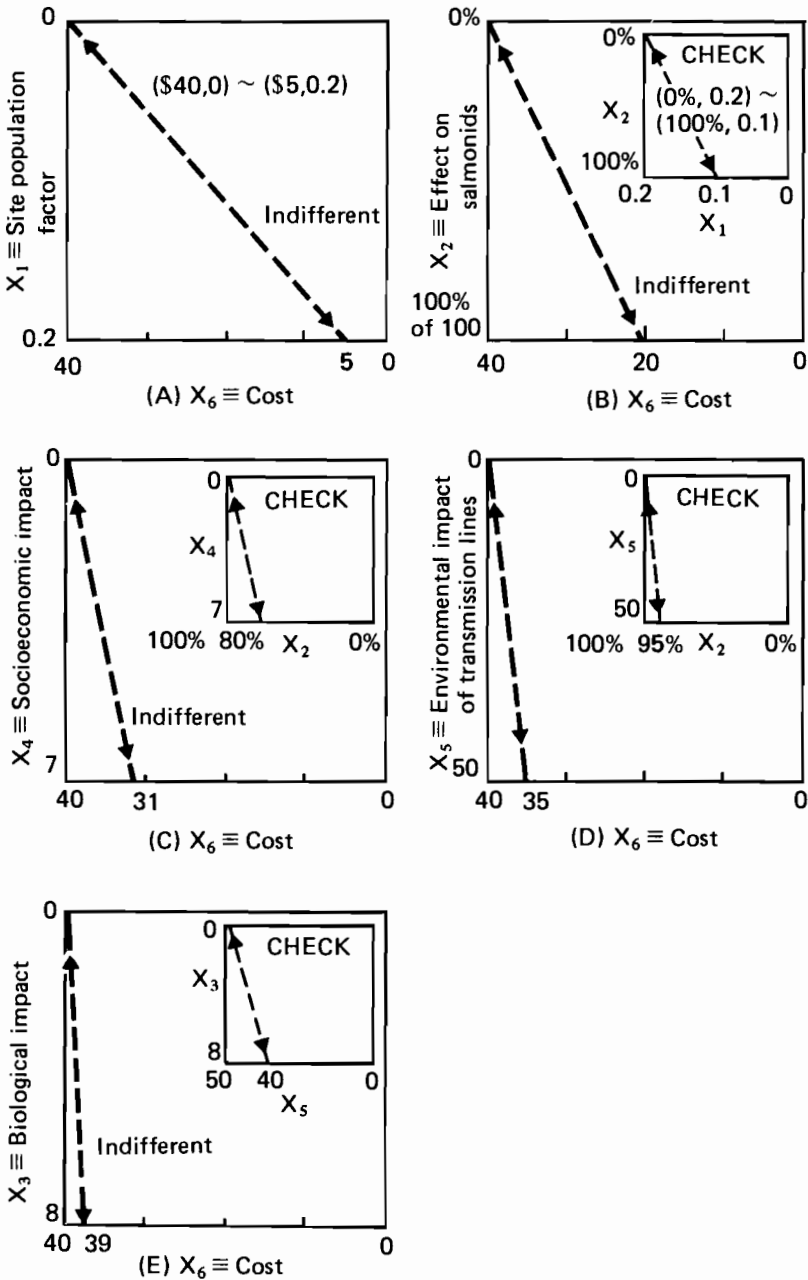

FIGURE 14.2 Trade-offs made in the assessment of scaling constants. The trade-offs in the insets are checks.

In order to check the consistency of the trade-offs, several other trade-offs not involving cost were established empirically. These are shown in the insets in Figure 14.2. They proved to be very consistent with the original assessments.

The next step in the assessment of scaling constants involved determining a probability p such that option C (a consequence with zero differential cost and all other attributes at the worst levels of Table 14.2) and option D (a lottery yielding either all attributes at their best levels, with probability p , or all at their worst levels, with probability $1 - p$) are indifferent. After consideration of several levels of p , the group's response was $p = 0.4$.

14.3.4 SPECIFYING THE UTILITY FUNCTION

Since options C and D are indifferent when $p = 0.40$, their expected utilities must be equal. By our choice of scale, when all attributes are at their best levels, $u = 1.0$; and when all attributes are at their worst levels, $u = 0.0$. Therefore, the expected utility of option D is $p(1.0) + (1 - p)(0.0) = p$. From (14.3), the utility of option C is k_6 , so

$$k_6 = p = 0.40. \quad (14.5)$$

The assessed trade-offs between cost and each of the other attributes are used to express all other scaling constants in terms of k_6 . Since k_6 is known, the other k_i values can be determined.

Consider the calculation of scaling constant k_1 , associated with attribute X_1 , the site population factor. By definition, the indifference points of the trade-off assessments must have equal expected utilities. Thus, from the indifference point of the assessed trade-off in Figure 14.2A, we know that

$$u(x_6 = \$40, x_1 = 0) = u(x_6 = \$5, x_1 = 0.2), \quad (14.6)$$

where we have not bothered to specify levels of the other attributes. However, because of the preferential independence conditions previously verified, we know that (14.6) is valid for all levels of the attributes X_2 , X_3 , X_4 , and X_5 . In particular, let us assume that the other attributes are at their worst levels such that $u_2(x_2) = u_3(x_3) = u_4(x_4) = u_5(x_5) = 0$. Then, using (14.3), the utilities in (14.6) are equated by

$$1 + kk_1 = 1 + kk_6(0.895),$$

which simplifies to

$$k_1 = 0.895 k_6. \quad (14.7)$$

From (14.5) we know that $k_6 = 0.40$, so (14.7) becomes

$$k_1 = 0.895(0.40) = 0.358.$$

The remaining trade-off constants can be calculated in an analogous manner, yielding the set

$$k_6 = 0.400, k_1 = 0.358, k_2 = 0.218, k_4 = 0.104, k_5 = 0.059, k_3 = 0.013. \quad (14.8)$$

The constant k is calculated from (14.3), given the k_i values. If (14.3) is evaluated with all attributes at their best levels (i.e., all utilities are 1.0), then k is the solution to

$$1 + k = \prod_{i=1}^6 (1 + k_i), \quad -1 < k \neq 0.$$

Using (14.8), the unknown k is calculated to be

$$k = -0.325. \quad (14.9)$$

The multiattribute utility function (14.3) is completely specified by the k_i 's in (14.8), the k in (14.9), and the single-attribute utility functions in Figure 14.1.

14.4 THE PROBABILITY ASSESSMENTS

The consequences associated with development at each site can be characterized by the levels the six attributes of Table 14.2 would assume should a power plant be constructed on that site. To account for the uncertainty associated with estimating the levels of the attributes, probabilistic estimates were made.

The estimation of the possible impacts at each site was accomplished in three forms. Attribute X_1 (site population factor) and attribute X_5 (length of power transmission intertie passing through environmentally sensitive areas) were assumed to be deterministic, as each was known with a high degree of certainty. For attributes X_3 and X_4 , measured by subjective indices, the probabilities that the impact would fall within ranges specified by two adjacent impact levels were assessed. The probabilistic estimates for attributes X_2 and X_6 were quantified by assessing the parameters – the mean and variance – for a normal probability distribution.

Assessing the probabilities over each attribute individually assumes implicitly that probabilistic independence exists among the attributes. After our initial assessments, the project team discussed this assumption in detail. We concluded that it was reasonable to assume that *conditional* on any alternative, the probabilities associated with the level of any attribute were independent of the level of any other attribute. Thus, for example, the probability of various levels of biological impact was independent of the level of impact on salmonids *given* a particular site.

14.4.1 THE ASSESSMENTS FOR EACH ATTRIBUTE

The probabilistic assessments for each site were based on existing information, site visits, and data developed during the study. Each attribute for each site was assessed by specialists in the relevant disciplines. Thus, the assessments represent the professional judgment of individuals based on their expertise and on all information currently available concerning the candidate sites. The resulting data are illustrated in Table 14.5, where we have labeled sites S1 through S9. We will describe briefly how each attribute was assessed.

TABLE 14.5 Probability Assessments of Attributes by Site^a

Attribute	Site								
	S1	S2 ^b	S3 ^b	S4 ^b	S5	S6	S7	S8	S9
X_1 (SPF)	0.057	0.04	0.025	0.048	0.044	0.023	0.052	0.011	0.018
X_2 (loss of salmonids)									
\bar{x}_2	8	8	8	15	15	15	15	4.3	3.65
$\sigma_{x_2}^2$	16	16	16	56.25	56.25	56.25	56.25	4.62	3.33
y	75	75	75	5.5	17	5	3	430	365
X_3 (biological impact at site)									
Range	1-2	1-2	1-2	2-3	2-3	3-4	3-4	0-1	0-1
Prob.	0.9	0.9	0.8	0.2	0.2	0.3	0.3	0.1	0.7
Range	2-3	2-3	2-3	3-4	4-5	2-3	1-2	0.5	1-2
Prob.	0.1	0.1	0.2	0.8	0.5	0.6	0.6	0.5	0.3
Range	5-6	3-4	5-6	3-4	3-4	3-4	2-3	0.4	0.4
Prob.	0.1	0.1	0.1	0.3	0.3	0.3	0.1	0.1	0.1
X_4 (socioeconomic impact)									
Range	1-2	1-2	1-2	2-3	2-3	1-2	2-3	0.1	1-2
Prob.	0.2	0.25	0.3	0.2	0.2	0.1	0.2	0.1	0.05
Range	2-3	2-3	2-3	3-4	3-4	3-4	3-4	0.4	2-3
Prob.	0.65	0.55	0.45	0.5	0.45	0.55	0.5	0.4	0.6
Range	3-4	3-4	3-4	4-5	4-5	4-5	4-5	0.4	3-4
Prob.	0.15	0.1	0.15	0.3	0.2	0.3	0.2	0.4	0.2
Range	4-5	4-5	4-5	4-5	5-6	5-6	5-6	0.1	4-5
Prob.	0.1	0.1	0.1	0.1	0.15	0.05	0.1	0.1	0.15
X_5 (length of inertie through sensitive environments, mi)	1	1	7	6	12	1	0	0	0
X_6 (differential cost \$10 ⁶ /y, 1955 dc llars)									
\bar{x}_6	2.035	0 (4.929)	1.535 (15.343)	1.933 (7.613)	12.347	17.713	4.834	10.936	11.423
$\sigma_{x_6}^2$	0.259	0 (1.518)	0.147 (14.713)	0.234 (3.622)	9.528	19.609	1.461	7.475	8.155

^a X_1 and X_2 were treated deterministically; probability estimates for intervals were used for X_3 and X_4 , and normal distributions were used for X_5 and X_6 .
^b Figures in parentheses include additional costs associated with elimination of possible liquefaction potential.

The Site Population Factor

To calculate the SPF using (14.1), it was necessary to know the number of people residing in concentric rings with centers at the candidate sites. This information was obtained from maps and census data.

Impact on Salmonids

The assessment of the reduction in the annual spawning escapement of salmonids was based on losses associated with construction of the cooling-water intake structure, with intake and discharge of cooling water, and with storage impoundments for cooling water. The impact on salmonids is dependent on the proportion of the river flow used for cooling water. Since the cooling-water requirements remain approximately constant for all candidate sites, the impact is determined by the size and characteristics of the river supplying cooling water. The salmonids that could be entrained are those passing the intake along the edge of the river. To be conservative, it was assumed that the concentration of salmonids was higher along the shore than in the middle. In the estimates of losses due to entrainment in Table 14.5 it was assumed that newly developed intake structures designed to minimize or virtually eliminate entrainment (i.e., Raney Well) would be used. The construction of the intake structure and storage impoundments would result primarily in loss of spawning and juvenile rearing areas.

Biological Impact at Site

The ecologists on the team were asked to assess the probabilities that the impact would fall between adjacent intervals on the scale for assessing the biological impact at each candidate site (Table 14.3). To help in thinking about this question, descriptions were developed for each site; two examples of summary descriptions of the existing biological characteristics are given below:

S6 The site region consists of varying proportions of mature second-growth forest, logged areas, and some small agricultural areas. There are a few small swampy areas and nearby wetlands. There is a high likelihood that Columbia white-tailed deer, an endangered species, may occupy the site or live nearby.

S9 This area is primarily agricultural, mostly wheat and potatoes, with small pockets of sagebrush habitat. There are no wetlands, and no endangered species are known to inhabit the area.

Socioeconomic Impact

A subjective evaluation was made of the likely socioeconomic effects of a nuclear plant on communities near each site. For each site, this required information concerning the percentage of the plant construction labor force likely to immigrate

and the existing characteristics of nearby communities, including population size, travel time from site to labor supply, age of community, type of public financing for which the community is likely to be eligible, size of the corporate area, role of the community in the region, and generalized land use patterns (used also to subjectively evaluate the tax base.)

Environmental Impact of Transmission Intertie

The length of the power transmission intertie passing through environmentally sensitive areas (i.e., land that was not clear-cut, cultivated, or urbanized) was assessed from field visits to each of the sites.

Annual Differential Site Costs

The economic comparison does not include a detailed estimate of the total cost of a plant at each of the candidate sites but is an evaluation of the differential costs of construction and plant operation associated with each site. Differential costs are measured relative to the least expensive site (S2). The comparison was based on current (1975) bid prices which were escalated to a proposed bid date of 1980 (on-line date 1985) using an 8.4 percent average annual rate of escalation. Allowances for contingencies, interest during construction, and bonding cost were included in the differential costs. The differential capital costs were converted to an annual cost expressed in 1985 dollars using an appropriate factor for cost of bonds and an estimated plant life. This nonescalatable annual cost, plus the annual differential costs of operation, formed the basis for the economic comparison of the sites. The cost estimates were developed using "standard power plant arrangements" at each of the candidate sites.

Site visits indicated that a potential for liquefaction of existing foundation materials under earthquake loading existed at sites S2, S3, and S4. Because the likelihood of liquefaction at these sites cannot be ascertained without site-specific studies, two cost estimates were made for the sites: one if the elimination of liquefaction potential is not necessary, and one if it is found to be necessary. The method of eliminating the potential for liquefaction that was used in making cost estimates was removal of the liquefiable foundation materials and replacement with suitable compacted fill. These additional costs were incorporated in the capital costs associated with site grading and are reflected in the annual differential site costs.

The primary cost estimates were average values. The uncertainty in these estimates was represented by a normal probability distribution, and it was assumed that the standard deviation was equal to one-fourth the mean values. Few data were available to justify this assumption, so we were particularly careful to check the cost estimates in the sensitivity analysis described in the next section.

14.5 EVALUATING SITES AND SENSITIVITY ANALYSIS

Since the cost of eliminating liquefaction potential is significant and since site-specific information could eliminate the uncertainty, it was considered appropriate to analyze the problem twice, first including potential liquefaction costs and then excluding them. The results would provide guidance on whether it would be worthwhile to obtain definitive information on liquefaction potential.

A small computer program was developed for evaluating the sites and conducting sensitivity analyses. Because of the utility-independence assumptions that were verified before selection of the utility function (14.3) and because of the assumption of probabilistic independence conditional on each alternative, it was appropriate to calculate certainty equivalents, attribute by attribute, for each of the alternatives. This gave us a six-attribute vector representing the "equivalent certainty impact" of each site. These were examined for dominance. No strict dominance existed, but there were several cases of "almost" dominance (one alternative preferred to another on all but one attribute). Thus, without introducing the full power of multiattribute utility, we could specify a reasonable ranking of the sites. In particular, the least preferred sites were easily identifiable. We proceeded to the utility analysis.

14.5.1 RANKING RESULTS BASED ON BEST ESTIMATES

The expected utility of each site was first calculated using the best estimates of all inputs for both the liquefaction and no-liquefaction cases. This resulted in two preferential rankings of alternatives, depending on whether liquefaction potential exists. Both the rankings and expected utilities indicate how much better one site is than another when all six attributes are considered. The differences in expected utilities for each site result from changes in all six attributes for the sites. However, it is easier to consider the significance of the difference in expected utility in terms of only one attribute. For ease in interpreting this significance, the differential cost of an "equivalent" site with attributes X_1 through X_5 at their best levels is shown in Table 14.6 for each site. This equivalent site is one with the same expected utility as the real site to which it is associated. Note, for instance, that the difference between the sites ranked first and fifth for both the liquefaction and the no-liquefaction cases is approximately 9 million 1985 dollars per year — a rather substantial amount.

14.5.2 SENSITIVITY ANALYSIS

The purpose of the sensitivity analysis is to investigate how the ranking of the alternatives changes if the inputs to the decision analysis differ from the best-estimate values. Sensitivity analyses were conducted both with and without costs associated with liquefaction potential. For each of these conditions, the sensitivity of the ranking to the scaling constants in the multiattribute utility function and to certain changes in the possible consequences was examined.

TABLE 14.6 Best-Estimate Ranking of Nine Candidate Power Plant Sites

Without Liquefaction Potential				With Liquefaction Potential			
Order	Site	Expected Utility	Annual Differential Cost of Equivalent Site ^a (10 ⁶ 1985 dollars)	Order	Site	Expected Utility	Annual Differential Cost of Equivalent Site ^a (10 ⁶ 1985 dollars)
1	S3	0.921	10.85	1	S1	0.894	14.60
2	S2	0.920	10.98	2	S2 ^b	0.887	15.53
3	S1	0.894	14.60	3	S7	0.854	19.89
4	S4	0.868	18.06	4	S5	0.843	21.30
5	S7	0.854	19.89	5	S4 ^b	0.827	23.35
6	S5	0.843	21.30	6	S3 ^b	0.822	23.98
7	S9	0.812	25.22	7	S9	0.812	25.22
8	S8	0.811	25.34	8	S8	0.811	25.34
9	S6	0.808	25.71	9	S6	0.808	25.71

^a An equivalent site is one of equal utility with all attributes at their best levels except for costs.
^b Additional site grading costs associated with correction of possible liquefaction potential included in analysis.

Changes in the Scaling Constants

The best-estimate values of the scaling constants k_i , $i = 1, 2, \dots, 6$, are given by (14.8). In the sensitivity analysis, the value of each k_i was increased and then decreased as much as possible without changing the order of these k_i 's. For example, k_1 was the second-largest k_i value, based on the best-estimate values. The adjacent values were $k_6 = 0.400$ and $k_3 = 0.218$. Therefore, two sensitivity runs were performed to investigate the influence of k_1 values of 0.399 and 0.219, which represents the range that maintains the same order of the k_i 's. The range for k_6 was varied from 0.358 (the value of k_1) to 0.500.

The analysis indicated the rankings of the sites remained essentially unchanged for all the changes in the k_i factors. Specifically, in the case where no liquefaction potential was assumed, there were no changes in the ordering of the best six sites. When liquefaction was assumed, there were a few changes between the sites ranked fifth and sixth, depending on the specific changes in the k_i 's. However, the sites ranked first through fourth maintained their positions.

Changes of Selected Consequences

The sensitivity of the rankings in Table 14.6 to the estimates of the differential costs and salmonid impacts was investigated. Specifically, we investigated separately the implications of each of the following four changes in possible impacts: increases in differential site costs of 20 percent and 50 percent, a change in the coefficient of

variation of the normally distributed site costs from 25 percent to 50 percent,¹ and the unavailability of a scheme to prevent entrainment of salmonids at the cooling-water inlets.

When liquefaction potential was assumed, there were no changes in the ranking of the six best sites for any of the variations mentioned. Assuming no liquefaction potential, S2 replaced S3 as the best site for 20 percent and 50 percent increases in the costs. This was the only change in the ranking of the best six sites of Table 14.6. In both cases, there were some changes in the rankings of the worst three sites.

14.6 CONCLUSIONS AND RECOMMENDATIONS

The results of the ranking process indicate that six of the nine candidate sites are superior to the other three under all reasonable variations of the preference structure and assessed consequences. The six sites are S1, S2, S3, S4, S5, and S7. Considering both the rankings (i.e., with and without liquefaction), the three sites recommended for detailed site-specific evaluation are S2, S1, and S7. If liquefaction potential is studied first and found not to exist at S3 and S4, then the three sites recommended for site-specific studies are S2, S3, and S4. In interpreting these recommendations, it should be noted that sites S1, S2, and S3 are close to each other.

Site-specific studies should concentrate on obtaining information to satisfy regulatory agency requirements. The most important of these are the geological, seismological, and geotechnical studies necessary to identify and classify lineaments and landslide potential. Additional studies to identify potential major environmental, socioeconomic, or cost impacts and to refine some of the cost data utilized in the ranking process should be conducted. Because of the site visits that have already been made, a lower order of effort is required for these studies.

The sites were identified and ranked on the basis of criteria described in this paper. There are several factors that were not considered in this study but that could have a significant bearing on the selection of a specific site. These include political and legal considerations, the distribution of plants, the future requirements of multiple plants at a site, and the reliability of the transmission grid.

The ranking process was based on the judgments and preferences of the project team. It is recommended that further studies be conducted to include the preferences and judgments of members of WPPSS. It may also be desirable to include, either explicitly or indirectly, the preferences and judgments of the general public.

The preferential ranking of the nine candidate sites is presented in Table 14.6. However, if the highest-ranking site is selected for construction, it does not follow that the second-best site in the original ranking should be chosen for the construction of the next plant. Because of the influence of the selected site on the

¹ An alternative way to state this assumption is that the standard deviation of site costs increases from 25 percent to 50 percent to 50 percent of the mean estimated costs.

desirability of the remaining sites, procedures should be developed to re-rank the sites after one site has been selected.

14.7 ACKNOWLEDGMENTS

Several members of the project team who contributed to the study deserve mention here. Among them are Gail Boyd, Steve James, Gordon Robilliard, Charles Hedges, Ashok Patwardhan, Dennis McCrumb, Don West, Ram Kulkarni, and Wayne Smith, all of Woodward–Clyde Consultants' staff. In addition, the firm of R.W. Beck and Associates provided valuable information on cost and transmission line considerations.

We were particularly fortunate to have a client who was willing to support the use of decision analysis techniques in the ranking process. Both the Public Power Council Siting Committee (Mr. William G. Hulbert, Jr., Chairman) and the WPPSS management (Mr. J.J. Stein, Managing Director) were supportive of our efforts. Mr. David Tillson, Siting Specialist of WPPSS, who monitored the contract, was a source of constant encouragement. Without his support, this study would not have been possible.

REFERENCES

- Keeney, R.L. 1974. Multiplicative utility functions. *Operations Research*, Vol. 22, pp. 22–34.
- Keeney, R.L., and H. Raiffa. 1976. *Decisions with Multiple Objectives*. John Wiley, New York.
- Keeney, R.L., and G.A. Robilliard. 1976. Assessing and evaluating environmental impacts at proposed nuclear power plant sites. PP76-3. International Institute for Applied Systems Analysis, Laxenburg, Austria.
- Nair, K., G.E. Brogan, L.S. Cluff, I.M. Idriss, and K.T. Mao. 1975. An approach to siting nuclear power plants: the relevance of earthquakes, faults, and decision analysis. In *Siting of Nuclear Facilities*. International Atomic Energy Agency, Vienna, pp. 435–472.
- Woodward–Clyde Consultants. 1975. Project No. WCC 74-682, prepared for Washington Public Power Supply System. San Francisco.

DISCUSSION

RIVETT: I am a little disturbed by your use of experts to judge utility functions that will be used to evaluate a decision that is in the public domain. If I were one of these experts, I would hate to assume that my utility function would be a good surrogate for that of the general public. We have had some major decisions in the United Kingdom, for example, on the location of factories in areas of great natural beauty where there was a tremendous outcry from the articulate middle class, but no outcry at all from the lesser paid workers who would ultimately get

the jobs in the factory. Those who know the system can make their voices heard, but a large proportion of the public does not. I have a suspicion that a politician who depends on the votes of the region might have been a more appropriate person to use in assessing the utility function.

TVERSKY: I see nothing wrong with using the expert to assess utility functions in the area of his expertise. The question is whether we let some people act outside their areas of expertise. The basic problem is in defining the boundaries of expertise. In the medical field, for example, physicians are certainly the experts in assessing the relationships between certain symptoms and diagnosis. They are certainly not experts in combining probabilities, and yet they are giving us those numbers. We should try to decompose the problem into areas where they are real experts, let these experts work on their part, and let somebody else do the rest.

EDWARDS: I have faced exactly the same question in my own work. Concerning preferences, there are two different classes of questions: questions about the characteristics of single-dimension utility functions and questions that have to do with trade-offs on different objectives. I feel that experts are appropriate to answer questions of the first class, such as preferences for the number of salmon in a river. But questions of the second class, concerning, for example, how important it is to worry about salmon as against worrying about the destruction of virgin wilderness, are public questions. Yet in your problem, you had the same team of experts generating the trade-offs and the individual utility functions. Would you agree that perhaps there is a public interest inherent in the trade-offs that is not the same as the public interest inherent in the individual utility function?

KEENEY: In theory, I agree with the point you are making. In practice, whether it is appropriate to have the same people make the trade-offs for the public depends on what the alternatives are. I think that in almost all important decisions, such as power plant siting, the decisions are made by some small group of selected people. This is the case whether we do anything like decision analysis or not.

In this discussion we are explicitly focusing on the trade-offs. I think it would be interesting to try to find out what the public opinion is on such a set of trade-offs. This might have been a reasonable way to use the overall analysis. In defense of the type of thing that we did, I'd say that because the trade-offs are a little more explicit than is often the case, the public and concerned citizens who were not formally involved in the analysis can clearly see our assumptions. Hopefully, this raises the level of debate and consciousness about what was done, and maybe this will lead to some modification and improvement in the decision when it is taken.

MEYER: There is another aspect of this whole mode of analysis that seems to make it inappropriate for this task. This study was focused solely on making trade-offs for siting a single power plant. By assessing a utility function for a single site, you are forcing a compromise of feelings into the utility function. Yet, in practice, a sequence of plants will be sited. Considering the sequence of plants offers a marvellous opportunity for giving one group what they want in some cases and another group what they want in others. With the present study, if you site two

plants, you may get two that no one is especially happy with. Explicitly recognizing the multiple siting situation may give a whole new scope for making trade-offs. I think this approach would also be much more in line with what the politician would do.

NAIR: The task we were given by our client was to select one site. In doing this, we found that there were three sites whose suitability was approximately equal, and we recommended site-specific studies for these. The selection of the best site will depend on the information from these studies.

KEENEY: Although we explicitly ignored sequencing aspects in the study, we did make it clear that when the next study is done after this first plant is built, the utility functions could change completely in light of the presence of the first.

MEYER: That was not exactly what I had in mind. It may be that in selecting the first site, the biologist really got his way. That makes a good case in the political process for the next study to allow the worker who is concerned with the direct economic consequences to get his way. Then you eventually get a portfolio of sites, each one of which gives someone something. As I understand this amalgamation process of utility function, it avoids doing that. It avoids sharp differentiation between who gets what in which decision.

KEENEY: The analysis we did does not explicitly indicate which group of people get what. The ecologist observes the impacts on the ecological attributes, and the economist the impact on the economic attributes, and so on. There is a little of this, but generally a clear indication of the information you are referring to is not available from our analysis. Had the problem been defined as the sequencing one, I would think it would have been very important to get this information.

15 A Community Information Feedback System with Multiattribute Utilities¹

Volker Bauer and Michael Wegener

All over the world, the task of planning and controlling the development of large conurbations seems beyond the problem-solving capacity of even highly developed social systems. In spite of immense capital investment and use of sophisticated technology, industrialized countries have failed to improve or even maintain living conditions in large cities. Urban sprawl, traffic chaos, collapsing public services, noise, and air and water pollution are indicators of the decline of the quality of urban life and have become the focus of growing citizen dissatisfaction with the urban environment and of conflicts between various interests.

The causes of the inability of large cities to cope with their most vital problems are various. They include the concentration of economic and political power in the hands of few relatively small segments of urban society, as well as the *de jure* and *de facto* limitations on the planning authority of communities and the inadequacy of municipal budgets in relation to the growing responsibilities of municipal administrations. They also include outdated land use legislation that makes rational allocation of land uses nearly impossible. They include, as well, the growing size, complexity, and vulnerability of the technical infrastructure; the growing interdependency and complexity of the economic and social environment; and the foreseeable depletion of natural resources like land, water, air, and energy. However, they also include the ever-growing expectations with which the population perceives and measures the results of urban planning.

The growing sensitivity of the population to local planning issues is expressed by increased demand for public services, by more frequent and more articulate statements of group interests, and by stronger claims for citizen participation in the local decision-making process. This tendency seems to be irreversible. With

¹The research reported in this paper was conducted at Battelle-Institut e.V., Frankfurt am Main, and supported by the Bundesministerium für Raumordnung, Bauwesen und Städtebau; the City of Vienna; and the Science and Human Affairs Program of Battelle Memorial Institute.

growing complexity the sociotechnoeconomic system becomes increasingly vulnerable to disturbances like sabotage, terrorism, or strike originating from small groups of outsiders or key insiders. It is this vulnerability, more than anything else, that forces government at all levels to base its authority on broad consent and cooperation rather than on coercion and technocratic control.

This perspective focuses attention on the participation of “plain” people, i.e., of nonexperts, in the local decision process. The difficulty lies in the fact that the management of a city is a highly specialized activity and is normally performed by experts – planners, economists, and administrators. How can these experts communicate with people not trained in matters like planning, economy, or administration, whose assent and cooperation, however, they have to win? The same system complexity that makes nonexpert participation necessary makes it nearly impossible for nonexperts to understand the decision alternatives or to introduce their preferences into the decision process.

One of the core problems of urban decision making, therefore, is the establishment of effective information feedback between experts and nonexperts about planning alternatives, consequences, and preferences. In this paper, an approach is presented that attacks this problem in two ways:

- By using dynamic systems simulation techniques to provide and process structured information on planning alternatives and their outcomes
- By using decision analysis techniques to provide and process structured information on the perception of the outcomes by experts and nonexperts

While both parts of the approach are of equal importance, the emphasis of the paper is on decision analysis. From a decision-analytic point of view, the urban decision situation is extremely complex:

Multiple objectives. Urban decision making deals with a large sector of societal life encompassing many closely interrelated subsectors. Each of these sectors contributes in some way to the overall success of planning.

Long time frame. Although urban change seems to proceed incrementally, many decisions in urban planning are indivisible, are irreversible, and have long-lasting effects.

Multiple interest groups. In no other field of decision making is the distinction between decision subjects and decision objects so elusive. The decision makers usually are part of the groups affected by the decisions.

Uncertainty. Only a part of the urban system can be influenced directly by public planning decisions. Decision outcomes depend to a large degree on the behavior of private actors.

Section 15.1 is an attempt to explicate more fully the urban decision situation and its problems. In section 15.2 the methodology designed to address some of these problems is introduced. Section 15.3 is a detailed account of the evaluation

component of the proposed methodology. In section 15.4 the first experimental applications of the methodology are reported. Section 15.5 is a critical appraisal of the methodology and a report on the outlook for further development.

15.1 THE URBAN DECISION PROBLEM

The ultimate goal of urban planning is to maintain and improve the conditions of life of the urban population at large. The failure of most large cities to achieve that goal suggests that a close look at the urban decision-making process is in order.

The urban decision-making process differs in many respects from decision-making processes in other fields, such as industrial or military planning. The first basic difference lies in the size and complexity of the decision object, the urban system. Urban planning deals with a complex sector of societal life that comprises nearly all aspects of human activity, such as living, working, travel, education, and leisure. For planning purposes, the system must be considered as a whole, as changes in one part of it affect elements in all other parts. Accordingly, the goal system that is to guide urban planning decisions must be comprehensive indeed if it is to cover all relevant aspects of urban life. This comprehensiveness is indispensable, as trade-offs are made between objectives from different aspects of urban life.

The second characteristic of urban planning is its relation to time. On the one hand, the physical plant, the social and economic structure of a city, changes only in small, marginal increments. This requires that the action set, as well as the goal system, be very specific and detailed. On the other hand, there are many decisions in urban planning that are basic, indivisible, and irreversible and that have long-lasting effects.

The third essential characteristic of the urban decision-making process lies in the relation between decision subjects and decision objects. Inasmuch as the objects of decisions are people who themselves might participate in the decision making, the distinction between decision subjects and decision objects tends to become irrelevant. The implications for the decision process are fundamental: even if the decision makers try to anticipate the assumed preferences of their clients, the single goal structure guiding the decision analysis has to be replaced by a multitude of goal structures representing the different perceptions of the "conditions of life" by various groups.

The fourth important difference in the urban decision-making process is that only a relatively small part of the urban system is in fact controlled by the planning authority. A far larger part is subject to individual decisions made by a large number of private individuals, groups, or organizations. The instruments that the public authority can use to influence the development of that larger "market" part are limited, even though the "conditions of life" depend greatly on the

functioning of the market sector. Therefore, the eventual consequences of decision alternatives are not easy to predict; as their prediction implies the consideration of the behavioral response of a large number of other actors, it is bound to contain a measure of uncertainty and error.

In summary, the urban decision-making process can be characterized by the following properties. It deals with a large sector of society that is at once decision subject and decision object. Because the object system is large and indivisible, the goal system has to be comprehensive and contain a large number of objectives. Because changes in the system occur on a micro scale, the alternatives and objectives have to be specified in great detail, yet there are some decisions that are long-term and irreversible. Because various groups of the city are affected by planning decisions, not one but many preference or goal systems have to be considered in the analysis. Because control of the urban system by the planning authority is only partial, prediction of decision consequences is particularly difficult.

If this is a valid description of the urban decision-making process, the next question is: How well does it work? The unsatisfactory state of large cities suggests that it does not work well. Of course, there is the convincing argument that even if it did work well, the troubles of cities would not be relieved, as their causes lie outside the jurisdiction of city governments. But it still seems likely that improvements in the urban decision-making process might at least help to improve the situation.

Therefore, a step-by-step inspection of the traditional practice in urban decision-making seems necessary if we are to find out why it does not work well. It soon becomes apparent why the traditional practice is in no way prepared to tackle the difficulties characteristic of urban planning. In the first place, the planner has only the vaguest idea of the goals and objectives that the plans, programs, or actions he designs are supposed to serve. Moreover, he has no analytic tools to predict any but the most trivial first-order effects of his action alternatives; he cannot forecast with any degree of reliability what the second-order and third-order effects of his plans might be throughout the urban system: how private actors — e.g., developers, homeowners, commuters — might respond. But even if he could, he would not be able to communicate these consequences in a comprehensible way to the decision makers and the people affected by his plans, because there are no tools to convey such complex technical material to people not trained in planning. By the same token, because the people affected by planning decisions do not comprehend what the consequences will be, they have no way of developing an informed opinion about the issues and of expressing their attitudes and interests in the matter, which, again, leaves the planner without badly needed information about the public acceptance of his projects and about the needs and aspirations of his clients.

Hence, insufficient information feedback may be identified as one of the major causes of malfunction of urban planning practice. Underlying this difficulty is the fact that the information-processing capacity of planners, decision makers, and the individuals or groups affected by planning is unequal to the complexity of the problems. This complexity cannot be reduced without losing sight of the substance of the problems themselves, nor can the necessity of feedback between experts

and nonexperts be dismissed without losing sight of the overall purpose of planning – improving the condition of people.

From this it follows that new tools are needed to support the dialogue between planning experts and nonexpert citizens:

By providing relevant and detailed information about direct and indirect consequences of planning decisions

By providing relevant and detailed information about the preferences of different groups in the population affected by planning

By relating the above two kinds of information and displaying them in a transparent format comprehensible to both planning experts and nonexpert citizens

In the following section a methodology designed to meet these requirements will be presented.

15.2 SIMULATION AND EVALUATION

The methodology presented in this paper consists of a combination of systems simulation and decision analysis techniques. In this section, the components of the proposed process – a multiperiod, multiregion, dynamic, digital simulation model of urban development and an evaluation procedure based on the multiattribute utility theory – will be described separately. Then it will be shown how these components are combined into an integrated process in which, by iteratively applying simulation and evaluation to planning alternatives, one or more planners, decision makers, or citizen groups may learn about the impacts of plans and the potential conflicts arising from them.

15.2.1 THE SIMULATION MODEL

Simulation is a scientific experiment on a model of the object of investigation, rather than on the object itself. If a mathematical model of the relevant characteristics of the investigated system is available, action alternatives to influence the development of the system may be tested with little risk and effort.

Mathematical simulation models for urban planning were first developed in the United States in the 1950s. In Western Europe, urban simulation models have been developed, mainly in Great Britain and Switzerland. In the Federal Republic of Germany, two major research projects on urban simulation have been conducted under research contracts with the federal government (Battelle-Institute, 1973; Popp *et al.*, 1974). The product of one of these projects is the urban simulation model POLIS, developed by Battelle–Frankfurt. The POLIS model simulates the development of the spatial distribution of population, employment, buildings, and land use, as well as of transportation, in response to planning interventions by the city or other public agencies over a number of time intervals (periods) until a planning horizon is reached. The urban area is divided into subunits (zones) whose

structure is represented by state variables. The zones are connected to each other and to the surrounding region by public transit and highway networks.

The simulation of a period begins with the analysis, description, and documentation of the state of the urban system. The analysis starts with the simulation of traffic flows of the base year. Travel times computed in the traffic model are used to calculate accessibility indices of all zones; these indices are a measure of locational advantage, afforded by the available transportation system, with respect to various activities and infrastructure facilities of the urban area. From accessibilities and other zonal attributes for each zone, attractivity indices are computed that express the market demand for land by various urban activities.

Next, the allocation part of the model begins. First, public action programs are executed. The model allows the introduction of time-sequenced and localized programs in housing construction; industrial development; and educational, social, recreational, and transport infrastructure. All construction programs are accompanied by necessary local roads and parking facilities, and all housing programs provide for service facilities like schools and neighborhood shopping and recreation areas. The remaining (private) construction activity is distributed over the urban area according to the market pattern of supply and demand within the restrictions of a zoning plan. The likely distribution of private construction for each type of building use is estimated as a function of the attractivity and capacity of each zone for that particular use. Displacement of one type of building use by more profitable types is considered in the model by demolition or explicit change in building-use type. After the simulation of private construction, projected population and employment are distributed over the available housing and commercial and industrial buildings, and demographic, social, and employment distributions are updated. Finally, the availability of local service facilities is checked against relevant standards. Where service is severely substandard, the city administration is assumed to intervene with an appropriate program.

This closes the simulation of the first period. The state variables of the model have received new values. The model starts, with changed parameters and new assumptions, the simulation of the next period. This cycle is reiterated until the last period has been simulated. For each simulated planning alternative, the model gives detailed information about the development of population, employment, physical structure, transportation, and environmental quality of each zone. In addition, the costs of each alternative are accumulated and exhibited as cash flows between various groups in the city.

The results of the simulation are documented in various forms of printed output – tables, diagrams, and maps. In addition, the levels of some 240 state variables for each zone, representing the demographic, employment, and building and land use structure of the zone and its service, transportation, and environmental characteristics, are stored for each time step of the simulation in a “historical” file. The historical file thus contains a point-to-point account of the likely consequences of all simulated alternatives in great spatial and temporal detail. After the simulation, the historical file is kept available for further analysis.

15.2.2 THE EVALUATION MODEL

Simulation models do not generate "optimal" solutions; they only describe the consequences of given solution alternatives. This "deficiency" turns out to be one of the essential advantages of simulation techniques. The experimental character of the simulation corresponds specifically with the iterative decision process of socioeconomic planning. Experiments with simulation models may be started without much prior knowledge about the planning problem itself, the constellation of goals, or their potential conflicts. The work with the model initiates a learning process about the interdependencies of the modeled system and about the consequences and interactions of planning interventions that allows an iterative approach to successively "better" solutions.

Simulation models thus, in a formal sense, are value-free. Judgments about the desirability of the outcomes have to be made outside the simulation model; without such judgments the outcomes would be meaningless. Hence, evaluation is an indispensable part of the simulation approach. It is only by evaluation that the simulation results that really matter are extracted from the large volume of information produced. Processing the results of a complex simulation model can be accomplished only by an efficient operationalized procedure.

For processing the results of the POLIS simulation model a formalized evaluation procedure for assessing the relative merit of plans for one or more goal structures was developed and operationalized in the form of a computer program. It is based on multidimensional scaling of utility as implied in the multiattribute utility theory (MAUT) (Raiffa, 1969; Bauer *et al.*, 1972; Humphreys, in press). MAUT proceeds by decomposing a complex object of evaluation (a plan) into its independent dimensions (attributes) through the use of a goal hierarchy. The attributes are individually evaluated by means of utility functions, weighted, and aggregated by a formal additive composition model. At each level of the hierarchy, the utility of the plan with respect to specific aspects is found, and at the top level the total utility becomes apparent.

Differences in the value structures of different groups involved in the planning process are expressed in the model by the same hierarchy but with different weights and utility functions. The program thus simultaneously evaluates the results of the simulation for goal structures representing the interests of different individuals or groups in the city. For use with the POLIS simulation model a goal hierarchy has been adopted whose elements are implied by the aspects of urban development contained in the model. The interface between the simulation and evaluation models is the historical file mentioned above. Following the instructions of the user, the evaluation program reads from this file for each zone the data required for the evaluation, translates them into utility-relevant attributes, and maps these attributes by means of utility functions on a standardized utility scale. After these two kinds of transformations, the simulation results enter the lowest level of the goal hierarchy, whence, subject to the underlying weighting scheme, they are successively

aggregated to higher-level, more general utility measures. Thus it is possible not only to evaluate straightforward indicators of system performance like housing quality, availability of services, and accessibility, but also to relate them to attributes of other problem areas as well as to more general utility aggregates, such as quality of life. The program calculates for all goal structures utility values for all levels of the hierarchy and for all zones or for any aggregates of zones. In addition, differences between the evaluations by different evaluators – i.e., potential conflicts – are shown.

15.2.3 THE LEARNING PROCESS

The combination of simulation and evaluation can be applied to the solution of planning problems in three ways:

- In its simplest form the combined process is a spatially disaggregated evaluation procedure. Only one goal system is used – e.g., urban development goals as formulated by the municipal legislature. In principle, any past, present, or future state of the city may be checked against that goal system. If only one such state is evaluated, the model shows spatial disparities in the distribution of public services and other indicators of quality of life. If more than one plan is evaluated, comparisons between plans on each desired level of spatial, temporal, or sectoral disaggregation may be made.

- If different goal systems of various groups are assumed, the augmented procedure allows not only a comparison between plans but also a comparison between attitudes of different groups toward a single plan in any desired spatial, temporal, or sectoral detail. In addition, it is possible to analyze the differences between group attitudes and thus identify potential conflict zones or problem areas.

- In its most complex application the combination of simulation and evaluation is integrated as a part of the iterative solution-finding process of urban development planning. The following five steps may be identified:

1. Participants of the planning process define goals to be achieved by planning.
2. The planner is guided by these goals in formulating one or more plans in the process of design.
3. The consequences of the plans are predicted by the simulation model.
4. The consequences of the plans are measured against the predetermined goals in the evaluation model.
5. A plan that satisfies the goals of all groups is adopted; if no such plan is found, the process is continued in one of three ways:
 - a. The planner proposes a new plan that either contains new elements or modifies existing elements so that a compromise can be reached.
 - b. The participants agree to change their assumptions about future developments: i.e., they modify the simulation model.
 - c. At least one of the participating groups agrees to change the weights of its goals or its satisfaction standards: i.e., it modifies the evaluation model.

The motivation for these modifications comes from the growing information about the planning problem, the solution alternatives and their consequences, and the potential conflicts arising from them. This makes the solution-finding process an individual or collective learning process, in which, by iterative application of simulation and evaluation, a plan that is acceptable to all participants is achieved.

15.3 THE EVALUATION TECHNIQUE

Evaluation is the measurement, as objectively as possible, of the contribution of certain actions or programs to the achievement of individual or public objectives or goals. The dimension that is measured is utility, a function of three basic elements: the evaluator, the entity being evaluated, and the purpose for which the evaluation is being made (Edwards, 1971).

In the urban planning context the object of evaluation seems to follow from the obvious purpose of evaluation – to make choices among possible programs. It seems, at first, obvious that the competing programs should be evaluated, but because of their instrumental character, it is not the programs but their consequences for the urban system that have to be evaluated. More precisely, it is the different states of the urban system resulting from the programs that constitute the object of evaluation.

The question of who does the evaluation will make things even more problematic. It has been argued earlier that urban planning represents one of the most difficult decision situations, one in which a large, complex sector of society is, at the same time, the subject and the object of decisions. Since urban society is not monolithic but consists of groups with usually divergent interests, all groups likely to be affected by the programs under debate should, ideally, participate in the evaluation. The methodology reported in this paper is typically applied, therefore, in the situation where the evaluation subjects are groups that represent different sections of the urban population whose interests in the problem at issue conflict. It may be noted that, with Arrow's theorem in mind (Arrow, 1963), no formal technique is provided either to aggregate evaluation judgments over groups or to aggregate group evaluations from individual judgments. Both aggregation steps are deliberately left to the informal process of group discussion and consensus finding. In fact, the group dynamics involved in the process of establishing consensus within and among the participating groups are considered to be an essential component of the learning process.¹

¹ That is, groups are, irrespective of their size, expected to end up with one single evaluation result, which formally looks exactly like an evaluation prepared by a single evaluator. Hence, the single evaluator can be considered a special case of the group evaluator. This makes the methodology also applicable to situations in which not groups, but one or more individuals, are to be the evaluators.

With the above definition of the evaluation object and subject, the definition of the purpose of the evaluation can be reformulated. While the effectuation of decisions remains the ultimate rationale of the evaluation, the informal intermediate steps of the process become more and more important, the steps of incrementally approaching consensus within and between the evaluating groups. Only if evaluation techniques can be successfully integrated into the process of social learning are they likely to play any part in urban decision making.

15.3.1 THE MAUT PROCEDURE

The principal concept of multiattribute utility theory is simple: The evaluation object, here the "city," is decomposed by means of a hierarchical, descriptive model into its relevant dimensions. The dimensions at the lowest hierarchical level are operational: i.e., they are measurable attributes or indicators for intangible attributes of the evaluation object. The individuals or groups participating in the evaluation assign relative importance weights to each element of the hierarchy. In addition, the evaluators attach to each of the attributes of the lowest level of the hierarchy a transformation or utility function that determines a utility value for each plausible value of the attribute. In a final step, for each element of the hierarchy, a utility value can be calculated as a weighted average of all lower-level elements that are associated with that element by using the additive model of MAUT¹:

$$u_i = \frac{\sum_j w_j u_j}{\sum_j w_j},$$

where u_i = utility of element i ; u_j = utility of lower-level elements j associated with i ; and w_j = importance weights of lower-level elements j .

In this particular application the values of the lowest-level attributes of the hierarchy are provided by the urban simulation model. Utility functions are weighted and designed by each participating individual or group separately. For each of them and for each plan one utility value is generated for each element of the hierarchy, including a total utility value for the top-level element.

15.3.2 GOAL HIERARCHIES

The term "goal hierarchy," used traditionally in multiattribute studies, is misleading. The hierarchy does not involve any normative aspects; it is simply understood as a set of rules to represent a complex object: a descriptive model. The descriptive model is value-free insofar as it is complete.

¹The conditions for the validity of the additive model are discussed in Bauer *et al.* (1972, pp. 36-39). It may be noted that this formulation of the model is wholly deterministic, leaving the problem of uncertainty to a later discussion.

The generative rules of the hierarchical model originated in the tradition of medieval logic:

1. A hierarchy is a configuration of interrelated elements arranged in levels.
2. Each element of the hierarchy is completely represented by the associated elements on the next lower level.
3. The elements of the hierarchy are independent dimensions of the associated element on the next higher level.

Various techniques for the construction of hierarchies have been reported (Bauer *et al.*, 1973, pp. 17–40). If the conditions of the hierarchy are strictly observed, the result will be a complete description of the evaluation object in the form of a tree. Each level is in itself a complete description of the evaluation object, with generality or abstraction decreasing from the top to the bottom. The lowest-level attributes must be directly measurable if the hierarchy is to be operational. This requirement determines the number of levels and elements of the hierarchy.

The hierarchical model of utility is favored because the acceptance of its restrictive conditions allows the application of the simplest conceivable mathematical model of utility aggregation: addition. Besides this, there is one more reason for the retention of the hierarchy: as indicated above, there is usually more than one plan evaluated and more than one individual or group participating in the evaluation. This means that the numbers that matter are not so much the calculated utilities in absolute terms – which may be impaired by interdependencies between the elements – but differences between utilities, which may be considerably less affected by those interdependencies.

Given the above considerations, it seems advisable to use the hierarchical model, the additive form of MAUT. Furthermore, it seems permissible, for pragmatic reasons, to relax its exhaustiveness and independence assumptions:

1. The hierarchy need contain only those attributes that the simulation model is able to generate, provided the areas not covered by the model are carefully pointed out to the evaluators.
2. The attributes of the hierarchy need not be completely independent of each other, as long as care is taken to work with relative rather than absolute utilities.

These two assumptions, dictated by pragmatic considerations, will seem debatable to many.¹ But one can hardly see any alternative way to decompose an object of

¹In a 1974 meeting at Battelle (Frankfurt), H. Raiffa linked the concept of independence to the question of trade-offs between attributes: two attributes are independent of a third attribute if trade-offs between them do not depend upon the level of the third attribute. But this is “preferential” or “utility” independence, as opposed to probabilistic–technical or “environmental” independence, e.g., correlation of real-world phenomena. Raiffa argued that environmental interdependence is irrelevant as long as preferential independence is preserved to justify the additive model. At the same meeting, W. Edwards pointed to the robustness of additive models in the presence of input error, but he was concerned about the danger of double-counting associated with environmental correlation.

evaluation of such immense complexity as a city, if simplistic and intuitive judgments are to be avoided. Perhaps the hierarchy should be considered no more nor less than a syntactical skeleton displaying certain semantic conventions. The user of the hierarchy, different from its designer, does not really care whether this semantic relation holds in the real world or whether the elements are independent. From this perspective, the hierarchy functions in the communication process: it guarantees that evaluating groups with different educational backgrounds understand each other. If they talk about, say, public transit, then at least the semantic components of the term are unambiguously determined by its context in the hierarchy. Only by using this common linguistic base can differences between groups be recognized.

15.3.3 WEIGHTS

The descriptive hierarchy obtains normative character, i.e., it becomes a goal hierarchy, by weights and utility functions. This statement is based on the assumption that human judgment may be modeled (a) by determining for each element of reality a number that represents its importance relative to other elements and (b) by determining for each such element a function that represents the relation between the actual value of the element and the satisfaction of the evaluator.

In earlier tests the weighting technique of paired comparison was selected and demonstrated with a small attribute set (Bauer *et al.*, 1973, pp. 44–48). It soon became obvious that this technique becomes impractical if it is transferred to a goal hierarchy with a large number of attributes. Therefore, the weighting technique was modified in the following manner:

- The weighting is done separately for each cluster of the hierarchy. “Cluster” is used to denote any hierarchy element plus its subordinate element set on the next lower level of the hierarchy. In each cluster the sum of weights is defined to be one hundred. In addition, care is taken that no cluster contains more than eight or nine subordinate elements, in order to reduce the number of concepts to be handled simultaneously by the evaluators.

- Instead of paired comparison, a method of direct scaling was adopted for weighting the cluster elements. The evaluators are asked to decide upon the relative weight of each of the subordinate elements of each cluster — i.e., its relative importance for the utility of the associated element on the next higher level of the hierarchy.

- To further facilitate the weighting process, alternative sample weightings are provided by the project team, so that the evaluators may simply select one of the suggested alternatives. Figure 15.1 (right) contains examples of such weighting suggestions for a series of clusters on successively lower hierarchical levels.

- If the evaluators are groups, each one is requested to agree upon a single weighting scheme. They are encouraged to settle intragroup disagreement or

PUBLIC TRANSPORT

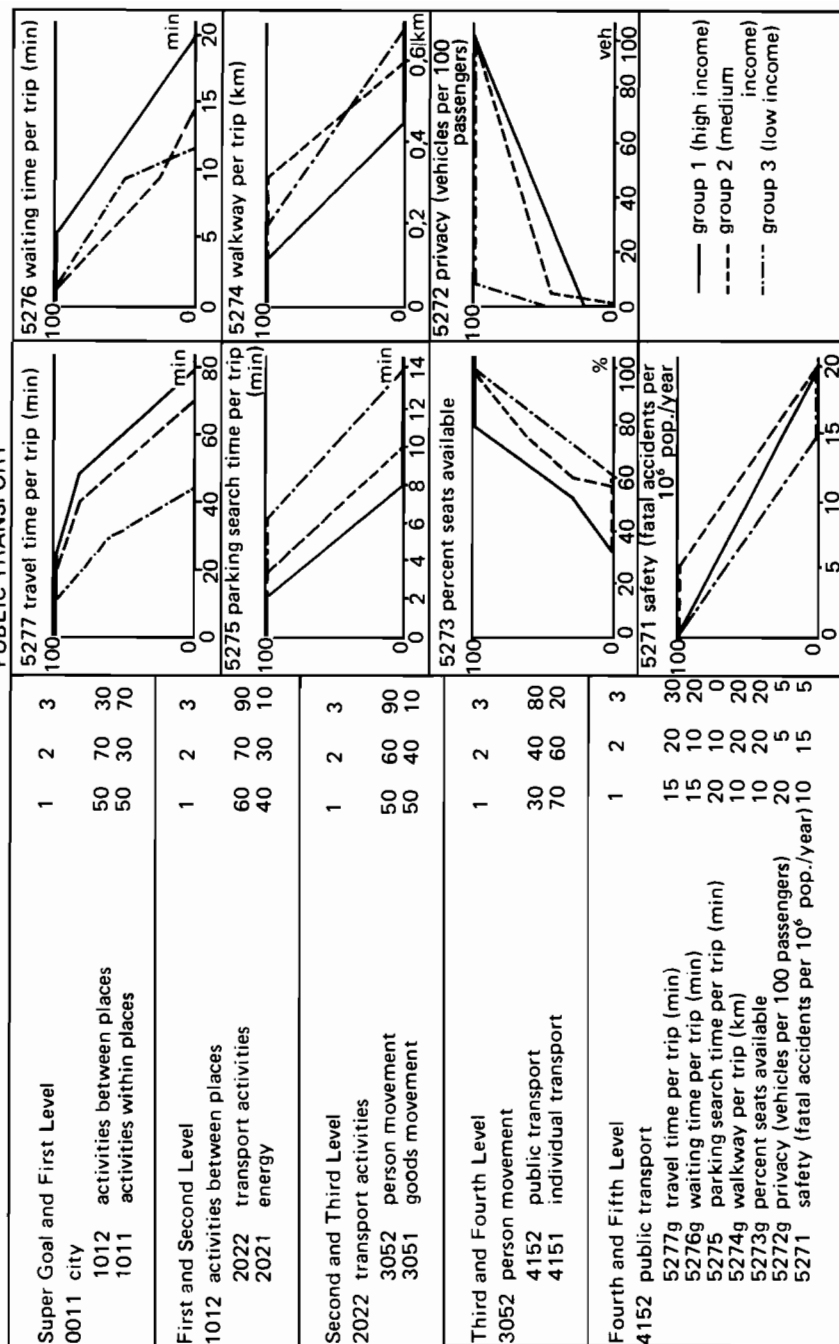

FIGURE 15.1 Excerpts from the POLIS hierarchy, with initial weights (left) and utility functions (right).

conflict by discussion rather than by formal rules like majority vote or averaging of individual weights.

- If an evaluator or a group of evaluators does not explicitly specify weights for any one cluster, a “default” weighting scheme taken from the sample weightings is automatically assigned. The project team specifies which of the sample weightings should serve as default for each group.

It may be argued that by handing out suggested weighting alternatives the project team is likely to influence the results. This clearly did not happen in the experiments, since in all cases the evaluators soon started to override the suggested weights by their own ratings. Rather, they used the suggestions as a kind of orientation to structure their discussion about the issues. The provision of “default” weights relieves the evaluators from the burden of working through every detail and, instead, frees them to concentrate on the issues that they feel to be most central.

The direct scaling technique itself may also be questioned. And, indeed, it may be a questionable practice to ask whether “housing” is more important than “education” without knowing the range or domain in which these aspects of urban life may vary.¹ However, this argument must be viewed in conjunction with the technique of cluster weighting and with the conventions used for the design of the utility functions, which will be discussed below. The cluster-weighting technique guarantees that the elements whose importance is to be compared are at least roughly comparable, since, by definition, they belong to the same aspect of the evaluation object and since they are likely to include no totally irrelevant items. The convention of designing utility functions, on the other hand, provides a semantic norming of the domains of the attributes, regardless of the actual numerical levels they may acquire later. These two circumstances help to convey to the participants a fairly clear understanding of what the weights really mean.

15.3.4 UTILITY FUNCTIONS

While the hierarchy and the weights establish the relation between a goal and all other goals of the goal system, the goal itself – its meaning, direction, and domain – is established by a utility function. The utility function represents the aspirations of the evaluator with respect to a certain goal, or, in other words, his ideas about the level of achievement that is desirable with respect to that goal. The utility function specifies for each goal whether it has been served badly or satisfactorily or well.

This leads to a distinction between two types of goals that have different types of utility functions. For the goals on all but the lowest level of the hierarchy the

¹ In Raiffa’s argumentation (expressed at the 1974 Battelle meeting), importance weights have meaning only relative to the scaling of the attributes: if the domain of an attribute changes, its weight should change, too. In Edwards’ more pragmatic view, the implicit specification of the domains of the attributes given by the context often must suffice, since frequently the actual range of the action alternatives is not known at the time the weighting has to be done.

type of function is already known: these goals are well served if their subordinate goals on the next lower level are served well. More precisely, the degree of achievement of such goals, or their utility value, is simply the weighted average of the utility values of the subordinate goals, with the weights provided by the weighting procedure. This is the weighting function underlying the additive model of MAUT.

The goals on the lowest level of the hierarchy are not amenable to such treatment because they do not have subordinate goals. Instead, they are defined to be independent dimensions or attributes of the evaluation object. While the goal hierarchy and the weighting scheme are concerned with general properties of all possible evaluation objects, it is at this point that the actual levels of the properties of a particular evaluation object enter the evaluation procedure. The second type of utility function serves to make that entrance possible. As the first type of utility function coincides with the additive weighting function of MAUT, the term "utility function" will be used exclusively for the second type.

The goals or attributes on the lowest level of the hierarchy may be any relevant aspect of the evaluation object, provided that they are operational or measurable on some nonarbitrary scale. Of course, one must expect that they come in many different dimensions – technical, physical, monetary, and so on. The utility function translates these differently scaled dimensions into the dimension that the evaluation model is intended to measure: utility. That means that one utility value has to be assigned to each plausible value of the attribute, no matter what scale it is measured on. It thus becomes apparent in which direction and by how much the attribute has to be changed to increase its utility by a certain margin.

If the attributes are not operational and measurable, evaluation still would be possible, but only on an *ad hoc* basis, by subjectively assessing the utility of a specific attribute level in a specific option environment. Hence, each option alternative would have to be evaluated directly by human evaluators. In most cases, however, this is neither desirable nor possible. Instead, the utility function provides a general transition rule by which even alternatives unknown to the evaluators may be evaluated. Thus, the operability of the attributes is indispensable; it allows *a priori* evaluations that can be applied to a whole category of action alternatives. On the other hand, the postulate of operability certainly does restrict the selection of more qualitative attributes of the evaluation object for which appropriate indicators cannot be found.

Another problem of utility functions has to do with the independence assumption underlying the additive model of MAUT. Especially in the case of complex evaluation objects containing a large number of attributes, the independence assumption, whether it is "environmental" or "preferential" independence, is almost certain to be violated. At best, the attributes can be expected to be fairly independent of each other if they are allowed to vary only within a very narrow margin – that is, if the domains of the utility functions are very small. One way of securing additivity, therefore, would be to reduce the domains of the attributes as much as possible. However, this would prevent the evaluation of innovative

action alternatives with still unknown levels of attributes that may fall outside the restrictive domains, and assessing innovative designs is one of the very purposes of evaluation in planning.

The technique selected for designing utility functions reflects the above considerations. The most straightforward of all techniques, "curve drawing," was used and modified by analogy to the weighting technique applied:

1. The utility function of an attribute is defined to be a real-numbered function of the attribute value (AV), or level, or outcome, of that attribute. The value of the utility function, or the utility value (UV), of the attribute, is defined to be bounded between zero and one hundred, with the following semantic implications:

Utility Value (UV)	Attribute Value (AV)
0	A totally unacceptable outcome
100	The outcome that can be achieved by reasonable, good practice of planning

There are no restrictions on the character of the utility function within the above domain; in other words, it need not be monotonic, continuous, or convex, nor need it have a unique minimum or maximum.

2. For each lowest-level attribute one utility function has to be designed by each evaluator or group of evaluators. First, the utility function is discussed with the help of graphic representation. Then, the resulting curve is entered into the computation as a set of up to ten pairs (AV, UV). Thus, there is no need to define the function in terms of a mathematical expression. The sections of the curve between the points entered are approximated linearly by the procedure.

3. To further facilitate the process of designing utility functions, alternative sample utility functions are provided by the project team, so that evaluators may simply select one of the suggested alternatives, or define new ones. Figure 15.1 contains some examples of suggested utility functions.

4. If the evaluators are groups, each group is requested to agree on the selection of utility functions. As with the weighting, the groups are encouraged to settle intragroup disagreement by discussion instead of through a formal voting procedure.

5. If an evaluator or a group of evaluators does not explicitly specify a utility function for any one attribute, a "default" utility function taken from the sample utility functions is automatically assigned. The project team specifies which of the sample utility functions should serve as default for each group.

This technique has proven to have many advantages. In the experiments, the

evaluators quickly grasped how to read and interpret utility functions with the help of the sample utility functions handed out to them. They used the sample utility functions to focus their own discussion and usually settled on one of them without difficulty. As with the weights, the provision of “default” utility functions was extremely valuable in reducing the amount of evaluation work to be performed by the evaluators. In fact, only in this way is it possible to make such a large number of individual judgments within a reasonable length of time without losing sight of the important issues and of the larger context in which they must be seen.

15.3.5 CONFLICT MEASUREMENT

Two kinds of conflict may occur in the context of multiattribute evaluation:

- Conflict between goals (intrapersonal conflict): Two goals are said to be in conflict if the achievement of one of them reduces the probability of achieving the other. Almost everyone’s goal system contains many such conflicts.
- Conflict between people (interpersonal conflict): Two evaluators or groups of evaluators may have different opinions on the importance of goals and on goal achievement – i.e., they have different interests or preferences. Consequently, their evaluations may result in the selection of different alternatives.

While the weighting technique of MAUT takes into account the first kind of conflict, no formal procedure is provided for the second kind. Disagreement between or within groups is to be settled by informal discussion. However, this discussion may be supported by supplying information about the degree and constitution of the disagreement. Therefore, an attempt has been made to measure interpersonal conflict, or differences between evaluation judgments.

Mack and Snyder (1957) postulate three conditions for the existence of conflict between two groups:

Satisfaction of interests of both groups is impossible. Winning by one group implies loss for the other.

One group is more powerful than the other and is interested in keeping its power.

Both groups are aware of the difference between their interests and of the inequality in their power.

Obviously, only the first condition of conflict is addressed here, as no information about the distribution of power between the groups or their perception of it is available. Hence, the concept of conflict measured here is a rather narrow one: it is merely the divergence of preferences, expressed by different weights and utility functions; it may be termed latent conflict. However, detailed and concrete information is available about this kind of conflict.

There may be various ways of measuring differences between weights and utility functions of two evaluators or groups of evaluators. In this case, linear correlation was used. The Bravais–Pearson product–moment correlation coefficient was considered to be a good measure of similarity of judgment, a coefficient of +1 indicating complete agreement and a coefficient of –1 indicating complete antagonism between the groups. Three types of conflict measures were computed:

Correlation between the weights assigned to the goals by each group: a measure of agreement on priorities

Correlation between the utility values calculated for each plan using the utility functions of each group: a measure of agreement on satisfaction levels

Correlation between the weighted utilities of each plan for each group: a measure of agreement on achieved satisfaction

The latter two types of conflict measures can be calculated for each zone of the city, using zonal utility values. Thus, conflicts may be localized and traced back to their origins – lack of public services, unsatisfactory housing, or insufficient transportation, for example. Such localized conflict measures, however, are meaningful only when both groups live or work in that zone.

Since not only existing but also projected states of the city may be the object of evaluation, it is, in principle, possible to predict the occurrence of local conflicts. However, this facility must be used with caution. First, one must consider that the future states are evaluated on the basis of present knowledge and goal systems; potential changes of values and attitudes are, at least in the present form of the analysis, not taken into account. Second, the limited concept of latent conflict disregards the dynamics of genuine, or open, conflicts, which usually originate from causes that are beyond the scope of local planning. Nevertheless, it can be assumed that planning alternatives that reduce the amount of latent conflict may at least help to reduce the overall conflict potential in urban society.

15.3.6 COMMUNICATION OF RESULTS

It is essential to the success of a dialogue that the participants understand each other. Therefore, the communication of the results of simulation and evaluation to the evaluators is a critical step in the procedure and a prerequisite to the intended learning process.

At present, the standard printed output of the simulation and the evaluation model each consists of some 100 pages of tables, diagrams, and maps. In spite of careful design, much of it usually turns out to be irrelevant, while other information is required by the participants in the experiments that might have easily been provided from the computations performed. This indicates that the problem of communication of results is still largely unsolved. Much of the difficulty encountered may be attributed to the fact that interactive computer access was not available

at the time of the experiments, but even with interactive computing, the output options have to be carefully tailored to the information needs of the users. This is even more important when the users are not trained in the processing of large amounts of numerical information. In such cases, appropriate nonnumerical (i.e., graphic or textual) transformations of numerical information become important elements of the procedure.

A few guidelines for effective communication of the evaluation results to the evaluators can be derived from the experiments that have been conducted. Much depends on the ability of the person explaining the results to divide the information into digestible portions in order to avoid information overload. It is equally important always to relate the results to the interests and problems of the particular group addressed.

The communication of results usually starts with the most general information and moves from there to the concrete and specific. First, for each plan the total utility as seen by different groups is discussed. Next, this total utility is disaggregated into its components. They reveal in which sector of the goal hierarchy the different groups are well or badly served by each plan. The same type of analysis can be repeated for each goal cluster on each level of the hierarchy as desired.

In the next step, the analysis is augmented by the local dimension. On the most general level, the utility values of the zones as seen by any two groups may be plotted against each other. Zonal utility values of any goal for any group may be displayed in a map showing local disparities in the satisfaction of that goal.

From there, one or more zones may be selected for further analysis, zones in which the participating groups have a specific interest because they live or work there. For the selected zones, all previous steps of the analysis may be repeated. In addition, on the zonal level, utilities may be traced down to the attributes that caused them. By a listing of attributes with "critical values" it is possible to identify attributes whose improvement appears to be most urgent.

With all this information, the participants are prepared to understand the conflict measures. The most general measures of conflict apply to the whole city. Zonal conflicts may be displayed in conflict maps that show where there is a discrepancy between the satisfaction levels or the achieved satisfaction as perceived by any two groups. The information contained in the conflict measures has a two-fold function in the process: it helps the participants to find out where and how other groups are better or worse served by a plan, and it makes them realize where the achievement of their own satisfaction interferes with that of others. In addition, changes in the conflict measures over repeated applications provide a measure of successful adaptation of interests during the learning process.

Sample evaluation results are presented in section 15.4.

15.3.7 ITERATION

After a first cycle of simulation and evaluation, all input is reviewed, and the whole process is repeated. The iteration constitutes a learning process as the participants

act with improved insight into the behavior of the system that is to be planned.

From the first simulation and evaluation results each evaluator or group of evaluators has a fairly good perception of where the present plans are satisfactory and where or how they should be changed. The ideas of different groups on these changes will differ. As, obviously, only one plan can be executed, the divergent ideas must be consolidated.

The appropriate format of such consolidation is public bargaining. In the hypothetical environment of experimentation, this means some sort of organized gaming. It should be noted that even in reality such bargaining will remain in a sense fictitious, since in most countries there is no room for actual local planning decision outside the institutional bodies of the local legislature. The gaming session will result in guidelines for plan revision. In the experiments, a "planning commission" composed of members of all participating groups was constituted to design a compromise plan from these guidelines.

In addition, the evaluators are free to revise their goal systems. In most cases, they will start with changing the importance weights. From the preceding evaluation the evaluators know which attributes or sectors of the hierarchy are served less well than others. It may be assumed that most evaluators will shift additional weight to those attributes that seem to deserve more attention because of failure to achieve them. If this happens at the same time that the plan is revised, the overall rating of the plan may become worse, even though the plan has, in fact, improved.

Only after they have altered their importance weights are the evaluators likely to change their utility functions. People will decrease their aspirations or standards with respect to a goal only if they understand that these standards are completely unrealistic. On the other hand, an increase in aspiration levels seems plausible only if no other attributes have grave deficits, something that is hardly ever achieved.

15.3.8 ON UNCERTAINTY

A brief final comment should be made on the treatment of uncertainty in the proposed procedure. There can be no doubt that the outcomes of planning measures in urban planning over a long time frame are far from certain, as has been emphasized earlier. Nevertheless, as will have been noticed, the mathematical model of utility used in the procedure described here contains no term for the consideration of uncertainty. The rationale for this lies in the fact that a highly sophisticated prediction instrument, the simulation model, is used to predict the outcomes to be evaluated. If the consequences of the planning actions were predicted intuitively (which hardly seems possible), a subjectively estimated probability could, and should, have been assigned to each of them. This is not possible with the simulation results, as there has been no attempt so far to trace probabilities from model input to model output, and it seems very unlikely that such an attempt

should ever be successful. Hence, from the point of view of the evaluators, all model output has equal certainty, or equal uncertainty, which relieves the decision model of the necessity of distinguishing between different levels of probability.

Of course, this means that the reliability of the evaluation results can be no better than that of the simulation output. Still, it is assumed that this reliability is higher than that of a decision analysis based on intuitive prediction of outcomes.

15.4 WORKSHOP EXPERIMENTS

Although the simulation model alone has been applied to land use and transportation planning problems in Cologne and Vienna, the combination of simulation and evaluation has been tested in a series of experimental applications. For these tests, Darmstadt was selected as an “experimental city” because of its manageable size and the availability of data. The Darmstadt data, having been assembled and coded as required by the simulation model, served as the input for three experimental workshops with groups of different size and professional background.¹ Selected results of these workshops are presented below.

15.4.1 WORKSHOP ORGANIZATION

As a common basis for all three workshops three basically different alternatives for land use and transportation planning in Darmstadt were formulated with the help of staff members of the Darmstadt city planning department (Figure 15.2):

10/A New concentration of population and employment in the northern part of the urban area, combined with maximum investment for highway construction; no improvement of public transportation

20/B Incremental housing development added to old village cores; balanced transportation concept with moderate improvement of highway system and transit service

30/C “Antisprawl” concept with high-density corridor across the central city district; environment-conscious transport scheme with cutbacks on highway construction; new linear (individual-cabin-type) transportation system along inner city corridor

A fourth alternative is the hypothetical “zero” or do-nothing alternative (NV, for the German *Nullvariante*), which assumes no public planning actions whatsoever

¹ These workshops were held in 1973 and 1974. Participating in the first workshop were 26 researchers from various Battelle laboratories; the second workshop was held with 25 junior planning officials of the State of Hessen; the third workshop was conducted at the University of Karlsruhe with 22 postgraduate students of regional sciences.

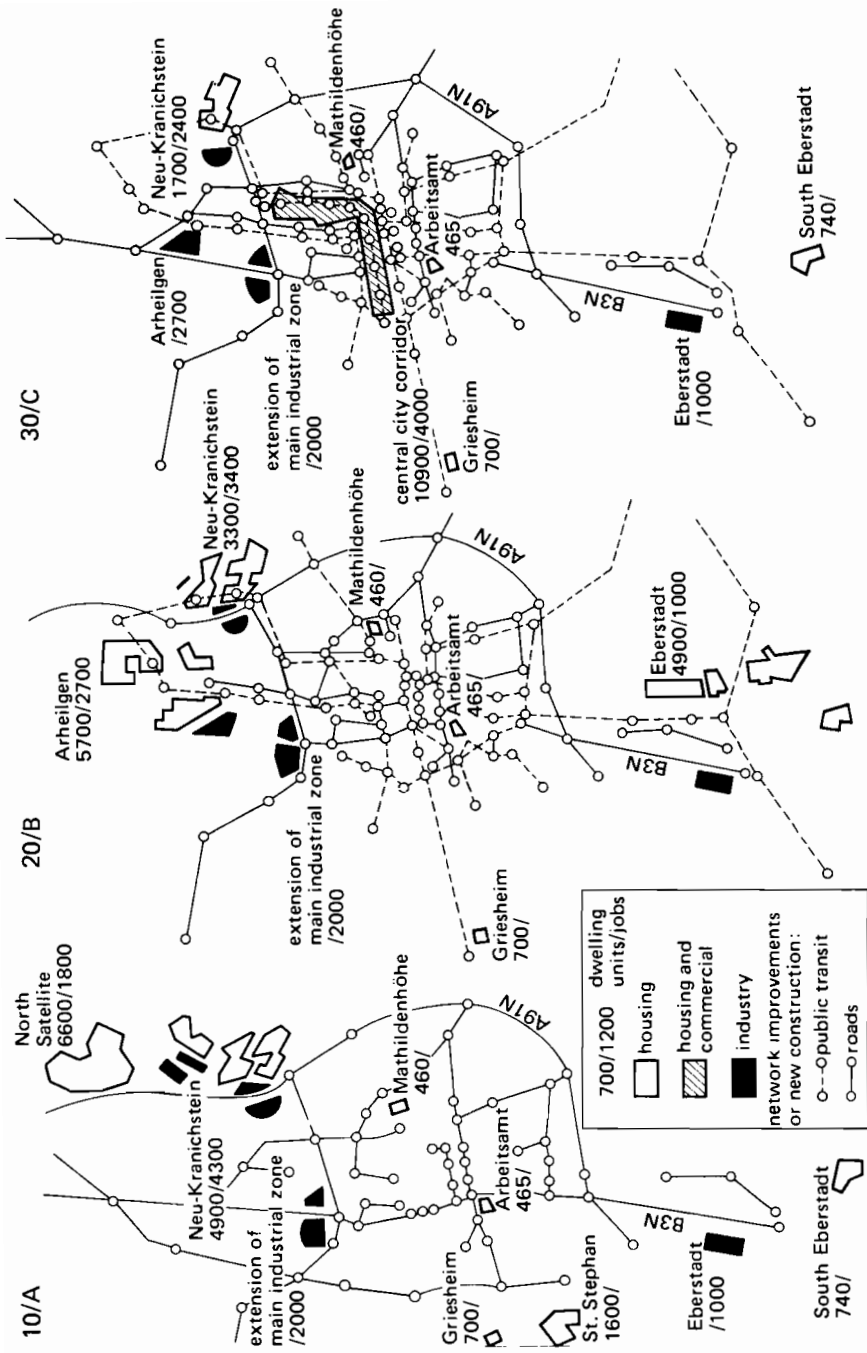

FIGURE 15.2 Darmstadt planning alternatives.

and represents pure market behavior. These four planning alternatives were prepared for input into the simulation model and simulated in advance for workshop use.

Because of lack of space it is not possible to illustrate the results of the simulations in this paper. It must suffice to say that the four alternatives differed widely with respect to land requirements, depletion of natural resources, traffic conditions, environmental quality, and costs for the public budget and for the society at large.

The workshops lasted from 3 to 5 days. At the beginning of each workshop the participants were divided into three groups representing socioeconomic groups (high, medium, and low income). To facilitate group identification, typical representatives of each socioeconomic group were described in written self-portraits included in the workshop material. The groups were asked to anticipate as well as they could the needs and interests of the socioeconomic group they were to represent and to make evaluations from that perspective. In workshops 2 and 3 the results of the preceding workshops were explained to the participants in an attempt to build upon the earlier experiences and thus make all three workshops a continuous learning process.

After the participants were briefed on the procedure and on general planning problems of Darmstadt, the workshops followed the sequence of steps shown below:

1. The results of the advance simulation of the four initial plans were presented to the participants. In workshops 2 and 3 the results of the preceding workshops were communicated as well.
2. The groups made their first evaluations.
3. The initial plans were evaluated with these initial goal systems. In workshops 2 and 3 plans generated during the preceding workshops were also evaluated.
4. In a gaming session the new results were discussed by the groups.
5. A "planning commission" consisting of two delegates from each group designed a "compromise" plan.
6. The groups revised their goal systems.
7. The compromise plan was simulated and evaluated with the initial and the new goal systems.

Because of lack of time only in workshop 3 was it possible to reiterate and re-enter the procedure with step 4, a new gaming session.

15.4.2 INITIAL RESULTS

In all workshops the first evaluation showed considerable differences in the attitudes of the groups toward the different plans and in the groups' satisfaction levels. The most interesting result was that, at the higher aggregation levels of utility, the group representing the medium-income sector of the population arrived at the

highest utility values for all planning alternatives. All plans seemed to meet the needs of the middle class, which may partly be explained by the fact that most planners are middle-class people. The lowest utility values were computed for the group representing low-income people, which may be considered self-evident.

Of the plans, least favored was the "do-nothing" alternative (NV), which seems plausible, as by definition this alternative does not attempt to solve any problem at all. However, the groups did not agree on the rank order of the remaining alternatives. The low-income and medium-income groups expressed a clear preference for the antisprawl concept 30/C, the plan that implies the most radical change of urban structure. These two groups might have agreed on this alternative, even though the middle class would derive more benefits from it. The high-income group, however, preferred the incremental-growth alternative (20/B), an alternative that implies only minor changes compared with the "do-nothing" alternative. Table 15.1 shows the total utility of the four initial plans as seen by each group after the initial evaluation of the first workshop. All utilities shown are computed for the simulated system state 25 years after the base year, i.e., for the year 1995.

The numerical differences between the utilities of the plans may seem to be relatively small. This raises the question of the sensitivity of the evaluation procedure to input changes. Formally, utilities may vary, by definition, between 0 and 100. For utilities aggregated from a number of attributes, however, both extremes are equally unlikely as they imply that all subordinate attributes with non-zero weights have utility 0 or 100. For a given set of subordinate attributes the aggregate utility may vary only between the lowest and the highest utility value occurring in the attribute set. These extremes are still very unlikely as they imply that all less extreme attributes have zero weights. In summary, the "averaging of averages" implied in the additive model of MAUT causes, on the higher levels of a goal hierarchy, a strong tendency toward utilities in the medium range of the utility scale.

The conclusion from this is that the interpretation of aggregate utilities must consider relatively small differences. In addition, it suggests that the analysis should proceed from aggregate utilities to partial or disaggregate utilities whose domains tend to increase with disaggregation. An example of such disaggregated analysis is shown in Figure 15.3. The global utility values of alternatives NV and 30/C from the second workshop are disaggregated into their five components on the second

TABLE 15.1 Total Utility of Four Initial Plans, by Group (Workshop 1)

Income Group		Plan			
		NV	10/A	20/B	30/C
High	(1)	47.2	49.3	50.7	49.4
Medium	(2)	54.8	58.6	52.4	59.2
Low	(3)	39.8	43.8	41.2	44.2

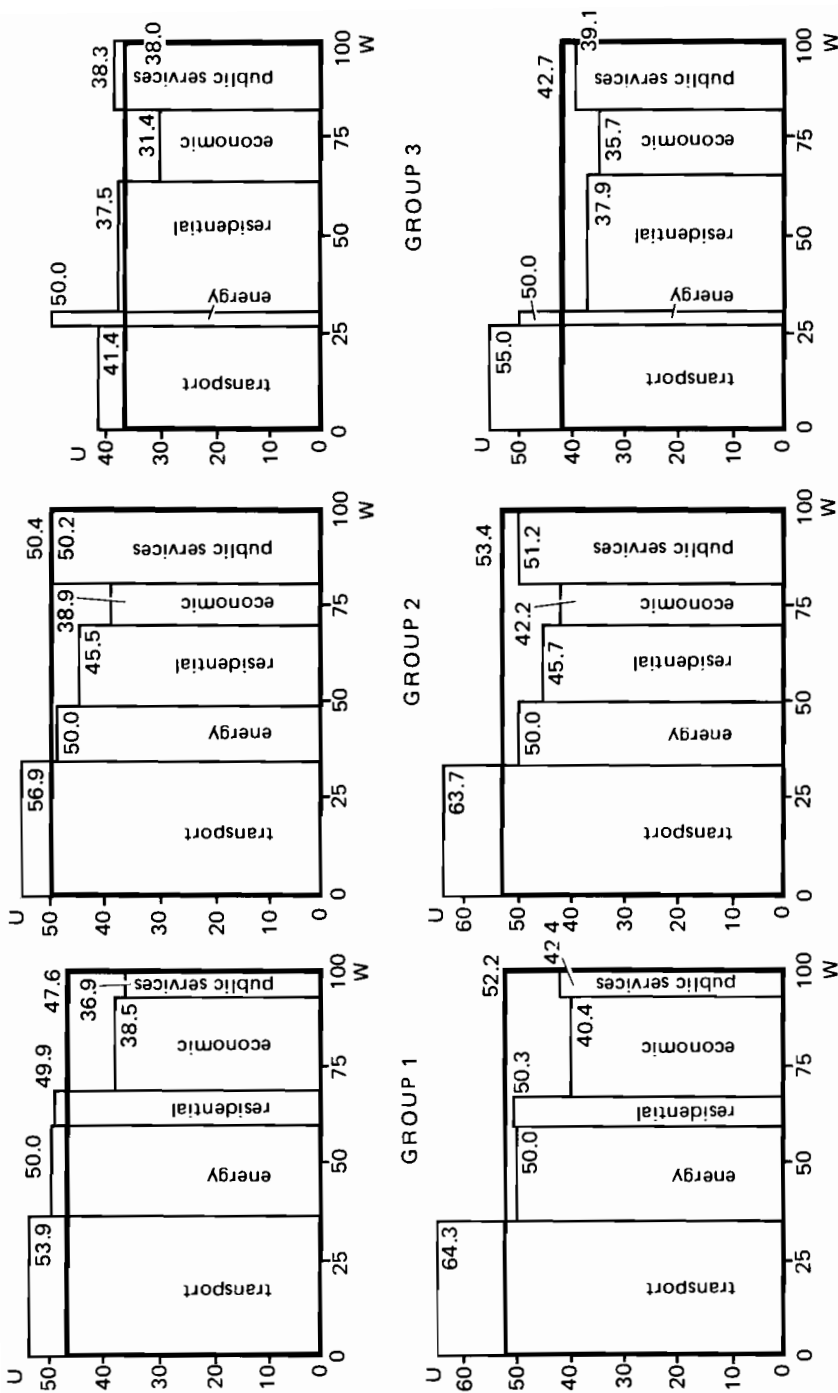

FIGURE 15.3 Sample of evaluation results: decomposition of total utility of plans NV and 30/C, from the second workshop. Group 1, high income; group 2, medium income; group 3, low income.

hierarchical level. Each of these components is depicted as a rectangle whose width represents its relative weight and whose height represents its utility value. It is readily seen that the improvement of plan 30/C over the do-nothing alternative is effected mainly by the improvement of transport services. One general observation can be made: the profile of the weighted utility values is largely determined by the weights. This can be explained by the fact that the standard deviation relative to the mean is much higher for the weights than for the utilities, and this difference tends to increase on the higher levels of the hierarchy.

Figure 15.4 shows results that are disaggregated locally as well as hierarchically. A zone was selected for each of the three groups; each zone is populated predominantly by members of the socioeconomic segment represented by the group. In this case the selected utility aggregates are not taken from the same hierarchical level, so their weights do not add up to 100. The most interesting result of this kind of analysis is that at the level of zonal utilities the differences between the groups are much more distinct than if they are aggregated for the whole city. For instance, the zonal utilities of group 3 are, with one exception, much lower than the global utilities averaged over all zones for the same group. For comparison, the respective global utilities are shown by broken lines. The conclusion from this is that, obviously, low-income people live in those areas of the city that they themselves consider to be less desirable. The reader may note that a similar analysis for the two other groups leads to quite different conclusions. (These findings suggest a modification in aggregating utilities over zones. Instead of averaging utilities weighted by total zonal population, only the population of the socioeconomic group for which the evaluation is made might be used as weights. It is likely that this would increase the differences of utility between groups.)

The above results help in the interpretation of intergroup conflicts as they are revealed by the evaluation technique. Conflicts between the high-income and low-income groups tended to be most severe, the major areas of conflict being the most favored, attractive, and expensive housing areas in the southeast part of the city, and the northern part of the city, where a new satellite is currently being constructed. The conflict intensity between the high-income and the medium-income groups and between the medium-income and the low-income groups, appeared to be generally lower, which again seems plausible.

15.4.3 ITERATION RESULTS

If it is supposed that repeated application of simulation and evaluation initiates a learning process for the participants, the changes of results after iteration are of specific interest. Two questions may be asked: (a) How do the utilities of plans change? and (b) Can the conflicts between groups be reduced? It will be shown that these questions are closely related.

To answer the first question, the total utilities of the compromise plans as designed by the "planning commissions" of the second and third workshops are

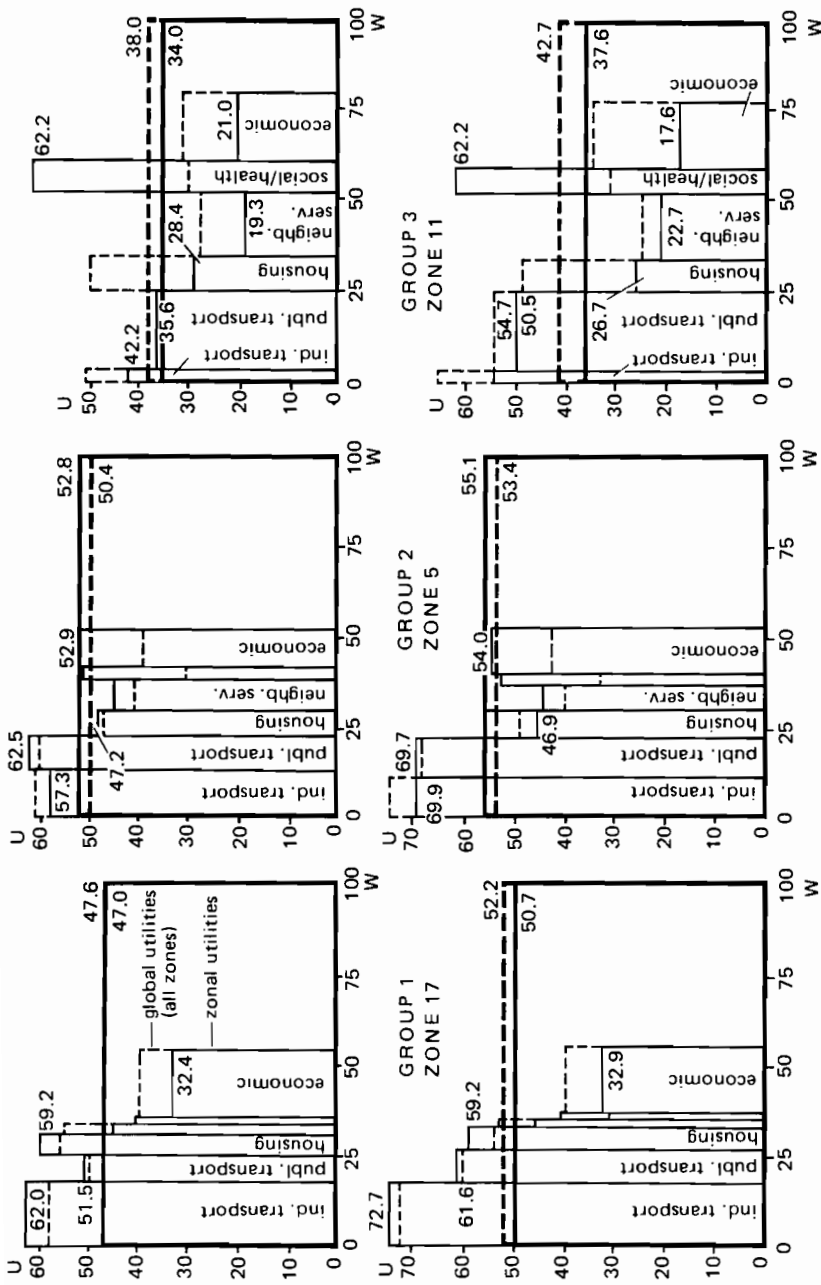

FIGURE 15.4 Sample of evaluation results: decomposition of zonal utilities (solid lines) and 30/C. Broken lines are global utilities (see Figure 15.3).

TABLE 15.2 Total Utility of Compromise Plans, Compared with Utility of Best Plans of Preceding Workshop, by Group

Income Group	Workshop 2		Workshop 3	
	30/C	31/E	31/E	32/F
High (1)	52.2	50.5	49.9	49.9
Medium (2)	53.4	51.8	48.0	48.4
Low (3)	42.7	41.6	41.6	42.5

TABLE 15.3 Total Utility of Plan 30/C in All Three Workshops, by Group

Income Group	Workshop		
	1	2	3
High (1)	49.4	52.2	49.2
Medium (2)	59.2	53.4	46.6
Low (3)	44.2	42.7	41.8

compared in Table 15.2 with those of the best plans of the preceding workshops, evaluated with the same goal systems. It can be seen that in the second workshop the compromise plan means a reduction of utility for all groups. Only the planning commission of the third workshop succeeded in improving the utility of the city. Even there, the gains in utility seem small compared to the amount of effort that went into the design of the plan.

There may be several reasons for this. First, the planning commissions worked under limitations of time and resources; only one iteration was performed. Second, the small degree of improvement may be an indication of the difficulty of influencing the conditions of life with the limited instruments of urban planning. The third reason may be the most important: "improving" the existing plans was not the only purpose of the planning commission; it also had the task of consolidating diverging opinions into a plan that was acceptable to all groups. One of the characteristics of compromise is that a gain in consensus may have to be paid for with a loss of satisfaction for all.

This leads to the second question, which concerns the reduction of normative differences between the groups. This process can be analyzed by looking at how the same plan was evaluated by groups with changing goal systems over time. Table 15.3 shows how planning alternative 30/C was evaluated in all three workshops. Obviously, the perceived utility of plan 30/C decreased from workshop to workshop. As the plan was always the same, this decrease must be attributed to changes in the value systems applied in the evaluation. In fact, a look at the distribution of weights on the second level of the hierarchy reveals significant shifts in emphasis (Table 15.4). The general tendency of these shifts was away from the technical aspects of urban life, such as transportation and energy, and toward more socially oriented aspects, such as housing and public services. But, as pointed out earlier,

TABLE 15.4 Perceived Utility of Plan 30/C, at Second Level of Hierarchy, by Group and Workshop

Income Group	Transport	Energy	Residential	Economic	Public Services	Total
High (1)						
Workshop 1	30	20	10	30	10	100
Workshop 2	36	24	8	24	8	100
Workshop 3	28	28	9	27	9	100
Medium (2)						
Workshop 1	49	21	9	12	9	100
Workshop 2	35	15	20	10	20	100
Workshop 3	12	18	28	21	21	100
Low (3)						
Workshop 1	27	3	35	7	28	100
Workshop 2	27	3	35	18	18	100
Workshop 3	20	0	48	8	24	100

good transportation was the greatest asset of plan 30/C. Therefore, a shift of emphasis to less-well-served areas of the hierarchy must necessarily lead to a decrease in the plan's overall utility. These findings seem to underline the assumption that evaluators are likely to shift weight to attributes that rated low in previous evaluations.

It remains to be seen if these losses in perceived utility were compensated for by a gain in achieved consensus. Table 15.5 shows the development of the three kinds of correlation coefficients computed as conflict measures of plan 30/C. The numbers clearly convey the degree of similarity in the goal systems of the three groups. With respect to the weights (i.e., the relative importance of goals), there is

TABLE 15.5 Correlation Coefficients of Weights, Utilities, and Weighted Utilities as Conflict Measures

	Correlation Coefficient		
	Group 1-2	Group 1-3	Group 2-3
Weights			
Workshop 1	0.83	0.00	0.31
Workshop 2	0.87	0.07	0.20
Workshop 3	0.74	-0.22	0.13
Utilities			
Workshop 1	0.77	0.43	0.71
Workshop 2	0.63	0.71	0.72
Workshop 3	0.80	0.78	0.92
Weighted utilities			
Workshop 1	0.90	0.34	0.61
Workshop 2	0.91	0.20	0.38
Workshop 3	0.55	-0.21	0.27

TABLE 15.6 Correlation Coefficients of Weighted Utilities, Workshops 2 and 3

Income Groups Correlated	Workshop 2		Workshop 3	
	30/C	31/E	31/E	32/F
1-2	0.90	0.91	0.84	0.71
1-3	0.20	0.19	0.09	-0.16
2-3	0.38	0.38	0.29	0.27

fairly high consensus (correlation) between groups 1 and 2, less consensus between groups 2 and 3, and practically no consensus between groups 1 and 3. Clearly, the consensus decreased from workshop to workshop; this must be attributed to the shifts in weights discussed above. If one correlates unweighted utilities, the correlations are, in general, much higher. Here, the tendency is reversed. With each workshop, the agreement between the groups about the perceived state of the urban system increased. The conflict measures using weighted utilities show the combined effects of those two tendencies: consensus between the groups on their achieved satisfaction decreased from one workshop to the next.

A final inspection may show whether this tendency can also be observed in the development of consensus between the groups during the workshops. Table 15.6 shows conflict measures based on weighted utilities of the compromise plans designed in workshops 2 and 3 and of the respective previous plans. Clearly, disagreement between the groups on the satisfaction achieved by the plans again remained constant or increased.

These results are far from satisfying. They imply that in no case did the groups succeed in finding a substantially better plan or in reaching consensus on a compromise. For a decision aid designed to improve urban decision making, this looks like a poor performance. Could it be that increased dissatisfaction and disagreement are necessary first steps in the learning process, before real progress can be made? The experiments conducted so far have been too limited, both in number and in duration, to answer that question.

15.5 APPRAISAL AND OUTLOOK

In spite of the limited number of experiments conducted, a preliminary assessment of the applicability of the proposed procedure seems to be possible.

On the procedural-technical level, the following observations can be made:

- The procedure is accepted by the participants as a meaningful decision aid that supplies relevant information.
- The procedure is transparent and straightforward enough to be understood and operated by the participants.
- The procedure is flexible enough to respond to spontaneous input by the participants.

- The procedure provides the participants with insights into interdependencies of the urban system that they might otherwise have been unable to recognize.
- The procedure makes the participants realize that satisfaction of their own interests may interfere with that of others'.
- The procedure motivates the participants to cooperate in resolving conflict by compromise.

On the other hand, two problems still need to be solved if the procedure is to be successful:

- The output of the simulation and evaluation programs should respond more flexibly to the information needs of the participants.
- Feedback between the computer models and the participants should be made quicker, easier, and more economical in order to allow more iterations in less time.

Interactive computing and more sophisticated output media – multiscreen graphic displays, for example – seem to offer reasonable solutions to these two problems. It is expected that the application of such technology, in conjunction with more refined group-dynamic techniques, would help to make the group discussions more realistic and effective, so that, eventually, the distant goal of inviting “real” people to the sessions could be approached.

On the theoretical level, an unanswered question is how appropriate the assumptions underlying the evaluation procedure are with respect to the decision situation of urban planning. A preliminary answer will be given in two parts.

First, the restrictions under which the multiattribute model is considered valid are inspected for their applicability to the urban decision situation. It has been demonstrated in this paper that they are applicable only in a very crude, approximate manner. In particular, it has been shown that because of the immense complexity of the evaluation object, the conditions of data exhaustiveness, precision, and independence can hardly be satisfied: as the decision outcomes cannot be predicted intuitively, only attributes implied in the simulation model (which is far from complete) can be processed. But, as the number of attributes is still very large, only the crudest techniques for determining weights and utility functions (e.g., direct scaling and “curve drawing”) can be applied. And again, because of the large number of attributes, the time required to test the independence of each one would be prohibitive. Moreover, it cannot even be expected that the attributes will be independent, either preferentially or environmentally. In summary, it must be concluded that, with respect to very large goal systems, the restrictions of the multiattribute model are far too great; they must be relaxed drastically if the model is to become practical.

Second, the multiattribute model itself – that is, its ability to portray human judgment in the context of urban decision making – is examined. The discussion will touch only briefly upon three important problems. The first of these is the additive model itself. The theory does not explain which part of human judgment is rep-

resented by utility or satisfaction as expressed by weights and utility functions. What does it really mean to multiply weights and utilities? In this paper, the assumption has been made that evaluators tend to shift weight to badly served attributes. If this is true, weights would, in a sense, be measures of dissatisfaction. Utility, in the additive model, would then be the sum of the products of dissatisfaction and satisfaction. Does this make sense? At least it makes the interpretation of weighted utility values extremely difficult. They can no longer be seen as an expression of pure utility; they might instead express the interest of the evaluator in changing the appropriate domain of reality. To put it simply, the "utility" of an important attribute with a low satisfaction level is *not* the same as that of an unimportant attribute with a high satisfaction level, although MAUT would suggest that it is.

The second problem is the static nature of the multiattribute model as it is presently applied. This problem becomes critical when the simulation and evaluation models are combined: the evaluators are to evaluate future states of the city with current values. Obviously, goal systems change with time, either in response to changes in technology and life-style or in adapting to changes in the goal systems of others, or because the limited perceptual capacity of man prevents the evaluators from perceiving more than a small portion of their total goal system at any one point, which forces them to periodically update their awareness of their own preferences. Only this last type of short-term adjustments of goal systems is dealt with adequately by the intended learning process. The treatment of long-term changes of goal systems would require the design of a dynamic simulation model of urban value structures that would be no less complex than the simulation model of the real city. As such a model would have to contain feedback cycles, it is very unlikely that the model structure of a dynamic MAUT would still be the additive, hierarchical model. [Some thoughts on dynamic simulation of goal systems are contained in Bauer and Wegener (1975, pp. 412–413).]

The third problem is the limited concept of rationality implicit in the multiattribute model, as it is in most decision analytic approaches. Following this concept of rationality, a rational decision consists of the selection of the action alternative with the highest utility with respect to a given set of goals. The goal system is taken as fixed, its validity depending only on its being as errorless as possible — that is, on its representing the goal system of the decision maker as truly as possible. With multiple-group decision making, conflict analysis, and the possibility of feedback, this concept of rationality becomes obsolete. Now the goals, too, become dependent variables and are subject to change. The situation of the decision makers has changed: they have to decide which interests their decisions are going to serve; they are becoming aware of their partisanship. Rational decision making now implies the awareness of partisanship, and the validity of a decision analysis depends on the extent to which it reveals this partisanship. Decisions must finally be made. This means that at some point the learning process has to be stopped, but when? When all participants are satisfied, or when no more improvement of plans is possible?

It has been the purpose of the last three paragraphs to show that the multi-attribute model of MAUT, in its present form, is by far too restrictive in scope, too insensitive to change, and too limited in its concept of reality to encompass human conflict resolution behavior in complex decision-making environments like urban planning.

There are no easy solutions to these problems. A few pragmatic attempts to deal with some of them have been discussed in this paper. While all of the problems will offer opportunity for research for some time to come, further work in two directions seems particularly important. One line of development would try to improve the feedback mechanism by integrating simulation and evaluation models in one interactive model. With this tool, more realistic gaming techniques and guidelines for conflict resolution could be devised. The other line of development would attempt to simulate urban preference structures in a dynamic MAUT model.

REFERENCES

- Arrow, K.J. 1963. *Social Choice and Individual Values*. 2nd ed. John Wiley, New York.
- Battelle-Institut e.V. 1973. Simulationsmodell POLIS. User Manual. Research Report 03.012. Bundesministerium für Raumordnung, Bauwesen und Städtebau, Bonn.
- Bauer, V., A. Gebert, and J. Meise. 1973. Urban Systems Studies. Part One, Evaluation in Urban Planning: Report. Battelle-Institut e.V., Frankfurt.
- Bauer, V., J. Meise, and M. Wegener. 1972. Urban Systems Studies. Part One, Evaluation in Urban Planning: Approach and Project Plan. Battelle-Institut e.V., Frankfurt.
- Bauer, V., and M. Wegener. 1975. Simulation, evaluation, and conflict analysis in urban planning. *Proceedings of the IEEE*, Vol. 63, pp. 405–413.
- Edwards, W. 1971. Social utilities. In *Decision and Risk Analysis – Powerful New Tools for Management*. Proceedings of a symposium. U.S. Naval Academy, Annapolis, Maryland.
- Humphreys, P. In press. Applications of multiattribute utility theory. In *Decision Making and Change in Human Affairs* (H. Jungermann and G. de Zeeuw, eds.). D. Reidel, Dordrecht, the Netherlands.
- Mack, R.W., and R.C. Snyder. 1957. The analysis of social conflict: toward an overview and synthesis. *Journal of Conflict Resolution*, Vol. 2, pp. 17–19.
- Popp, W., U. Ammer, B. Dejon, O. Stradal, and E. Zepf. 1974. Entwicklung des Planungsmodelles SIARSSY. Research Report 03.018. Bundesministerium für Raumordnung, Bauwesen und Städtebau, Bonn.
- Raiffa, H. 1969. Preferences for Multiattributed Alternatives. Memorandum RM-5868-DOT/RC. Rand Corporation, Santa Monica, California.

DISCUSSION

EDWARDS: My results are almost diametrically opposite to yours with respect to the question of whether such analyses lead to less conflict among the participants. One possibility that occurs to me for explaining the difference between what you found and what I found is that you were not working with actual members of these disagreeing communities; rather, you were working with people who are instructed to think of themselves as surrogates for these members.

WEGENER: We have a theory about why the procedure was not successful, in the way we had wished it to be, in reducing conflicts among groups. In modifying their goal structures, the groups were motivated by the desire to shift attention to those areas of the goal structure that in the first run were badly served for that group. This, of course, would result in a decrease of satisfaction for the group even if the compromise plan "objectively" increased in quality. Maybe we should design an experiment in which we change only one thing at a time, either the plan or the goal system. Our results might then be different.

EDWARDS: You posed a question at the beginning of your talk – who can tell you how to limit the number of dimensions? It seems to me you answered your own question: you did it yourself.

WEGENER: But when should it be done? Should it be done before we enter the decision analysis or during the decision analysis? One could ask: Why do you start with so many attributes? We had no way of eliminating any of them before we entered the decision analysis.

KEENEY: Then how did you eliminate all those attributes that were never included in the problem?

WEGENER: To be sure that you have not forgotten any attribute would mean increasing the number of attributes in the beginning, but, of course, you will never be able to include everything. The simulation model is the limit. The whole procedure can be only as complete as the simulation.

KEENEY: Although I have had no experience with a problem involving as many attributes as yours, I do have an idea that may be useful in eliminating some of the attributes before going through an analysis. At the beginning of our problem, let us say we have developed 12 attributes. Rather than build a simulation model or work on the probabilistic aspects first, suppose we try to get the preference function or utility function. Suppose that it happened to be additive and we scaled it so that the sum of the weights was 1. It might be the case that 0.9 of that went with six of the attributes and the other 0.1 went with the six others. Then you might for a first cut eliminate those last six and evaluate alternatives on the scale from 0 to 0.9. If you were just looking for a best alternative, and if one is at least 0.1 better than any other alternative, then it would be the best even if the additional six attributes were included. More generally, if no single alternative has a utility 0.1 greater than all the others, each alternative that is at least 0.1 less than the utility of the best alternative – as indicated on just the six attributes – can be eliminated from further consideration. This can be used iteratively, starting with the heaviest weighted attributes and sequentially adding the next heaviest.

BELL: Did you make any attempt to examine the qualitative preference structure by examining trade-off considerations, for example, before assigning your weights?

WEGENER: I have only one answer for that. Can you imagine performing exotic things like marginality checks or independence checks with such a large number of attributes? I cannot and I am not sure if the average decision maker

is able to reasonably answer questions on marginality or on trade-offs even with a very small number of attributes.

RAIFFA: I think it is possible to check qualitatively whether preferences in one cluster are independent of those in another cluster. The fuzzier people are, the easier it is to construct a model that will reasonably represent their preferences. The aim in your work, as I understand it, is to concentrate on the trade-offs between groups. The only way that you can come to grips with the trade-offs between groups is to construct some reasonable preference model for each group.

16 Multiobjective Decision Making with Applications to Environmental and Urban Design

Y. Sawaragi, K. Inoue, and H. Nakayama

16.1 INTRODUCTION

The rapid advance of material civilization over the past two decades has produced many harmful effects on both human beings and their physical environment. Environmental degradation and destruction is widely recognized as a serious social problem. Because their causes and effects are complex and wide-ranging, the best approach to environmental problems may be an interdisciplinary one that includes politics, economics, sociology, medical science, and engineering.

Beginning in 1972, the Education Ministry in Japan conducted a 3-year research project on environmental pollution control; the project's emphasis was on an engineering approach. Some 200 researchers from Japanese universities were organized into several research groups. The first study discussed in this paper was performed as part of this project and deals with trade-off analysis of the problem of thermal discharge in steam power plants by using a new constrained optimization technique, the "multiplier method."

Also briefly described below is a project of the Systems Development Laboratory of Hitachi, Ltd., whose aim is the construction of a decision-making model to aid in analysis and prediction for carrying out urban administration policies and planning; the quantified consciousness of the public is introduced as a unified standard for decision making. The basis of the model is Hiroshima City, and the study was carried out in 1971–1973 by some 20 experts in such fields as engineering, economics, management, and psychology.

16.2 CONSTRAINED OPTIMIZATION TECHNIQUES AND TRADE-OFF ANALYSIS

Consider a system in which two or three criteria are to be minimized while other criteria are maintained within satisfactory ranges so that the decision maker can

make his decision with the help of the illustration of the trade-off relation between the criteria to be minimized. For example, consider the following problem:

Minimize

$$F = (f_1(x), f_2(x))^T$$

subject to

$$f_i(x) \leq b_i \quad i = 3, 4, \dots, m$$

and

$$x \in \Omega.$$

The trade-off relation between criteria f_1 and f_2 is easily illustrated by solving the auxiliary problem:

Minimize

$$f_1(x)$$

subject to

$$f_2(x) \leq b_2$$

and

$$x \in S,$$

where $S = \{x | f_i(x) \leq b_i, 3 \leq i \leq m, x \in \Omega\}$, and b_2 is perturbed over the domain $F = \{b | \text{there exists } x \in S \text{ such that } f_2(x) \leq b\}$. Since the auxiliary problem for fixed b_2 is a traditional optimization problem, existing optimization techniques may be applicable. Among them, the multiplier method (Sayama *et al.*, 1974; Nakayama *et al.*, 1975a, b) seems to be the most promising for several reasons:

It can be applied to general nonconvex programmings as well as to convex ones.

The optimal solution and the values of the Lagrange multipliers are obtained simultaneously.

It does not include any parameter increasing to infinity, and thus the process of convergence is stable.

The second feature is particularly pertinent to application of the method to the stated problem, since the Lagrange multiplier is the trade-off ratio between f_1 and f_2 .

The multiplier method is based on a generalized Lagrangian:

$$L(x, \sigma; r) = f_1(x) - \sum_{i=2}^m \sigma_i g_i(x) - \sum_{i=2}^m \begin{cases} r g_i^2(x), & g_i(x) \leq 0 \\ \frac{r \sigma_i g_i^2(x)}{\sigma_i + r g_i(x)}, & g_i(x) > 0 \end{cases} \quad (16.1)$$

where $g_i(x) = b_i - f_i(x)$. Here, any of the constraints except for $i = 2$ may be

excluded from $L(x, \sigma; r)$, and the region prescribed by them could be joined to Ω , if necessary.

The computing procedure is summarized as follows:

1. Set $k = 0$.
2. Choose a penalty parameter $r > 0$ and initial values of multipliers $\sigma^k > 0$.
3. Find x^k that minimizes $L(x, \sigma^k; r)$ over Ω .
4. Stop the iteration if one of the following criteria is satisfied:

$$\begin{aligned} |\sigma_i^k g_i(x^k)| &< \epsilon & i = 2, \dots, m \\ |f_1(x^k) - L(x^k, \sigma^k; r)| &< \epsilon, \end{aligned}$$

where ϵ is a sufficiently small positive number. Otherwise, go to (5).

5. Adjust σ^k in the following way:

$$\sigma_i^{k+1} = \begin{cases} \sigma_i^k - 2r g_i(x^k), & g_i(x^k) \leq 0 \\ \frac{(\sigma_i^k)^3}{[\sigma_i^k + r g_i(x^k)]^2}, & g_i(x^k) > 0 \end{cases}$$

and return to (3), setting $k = k + 1$.

As a simple example of the application of these techniques, we discuss the investigation of thermal discharge in a steam power plant (Inoue *et al.*, 1974). The power plant has an output of 300–500 MW and has a once-through cooling system. High-temperature, high-pressure steam is generated in a boiler. This steam is sent to the turbine, and the turbine drives the generator to produce electric power. The steam that comes out of the turbine is cooled in the condenser and resupplied as water to the boiler. The latent heat generated by the cooling and condensation of steam is transferred to the cooling water. The temperature of the cooling water is elevated, and the heat is transferred to the water source. The efficiency of the electricity generation depends on the temperature of condensed water from steam, and this temperature in turn is governed by the temperature of the cooling water.

In the steam power plant model, alternatives to once-through cooling, namely, recirculation path and dilution path, are considered. The model specified the relationships among costs of fuels, cost and availability of water, temperature and pressure at various points in the power plant, and so on.

One of the criteria to be minimized is the cost of generating electricity given by

$$C = P_f \cdot F + P_w \cdot W + P_h \cdot H, \quad (16.2)$$

where P_f is the price of fuel, including resource use tax (\$/Btu); P_w is the price of water, including resource use tax (\$/gal); P_h is the heat discharge tax (\$/Btu); F is the heat supplied to the boiler (Btu/kWh); W is the quantity of intake water (gal/kWh); and H is the waste heat removed from the condenser (Btu/kWh). Another criterion to be minimized is

$$DT = T_{\text{out}} - T_{\text{in}}, \quad (16.3)$$

where T_{in} and T_{out} are the temperature of the intake and discharged water.

A part of the result of calculation using the multiplier method described in this section is displayed in Figure 16.1 for a plant with $T_{\text{in}} = 70^\circ\text{F}$. Regulation of the temperature rise in cooling water DT is taken as abscissa and the minimum cost C_t^* is taken as ordinate. The effect of regulation of the temperature differential of

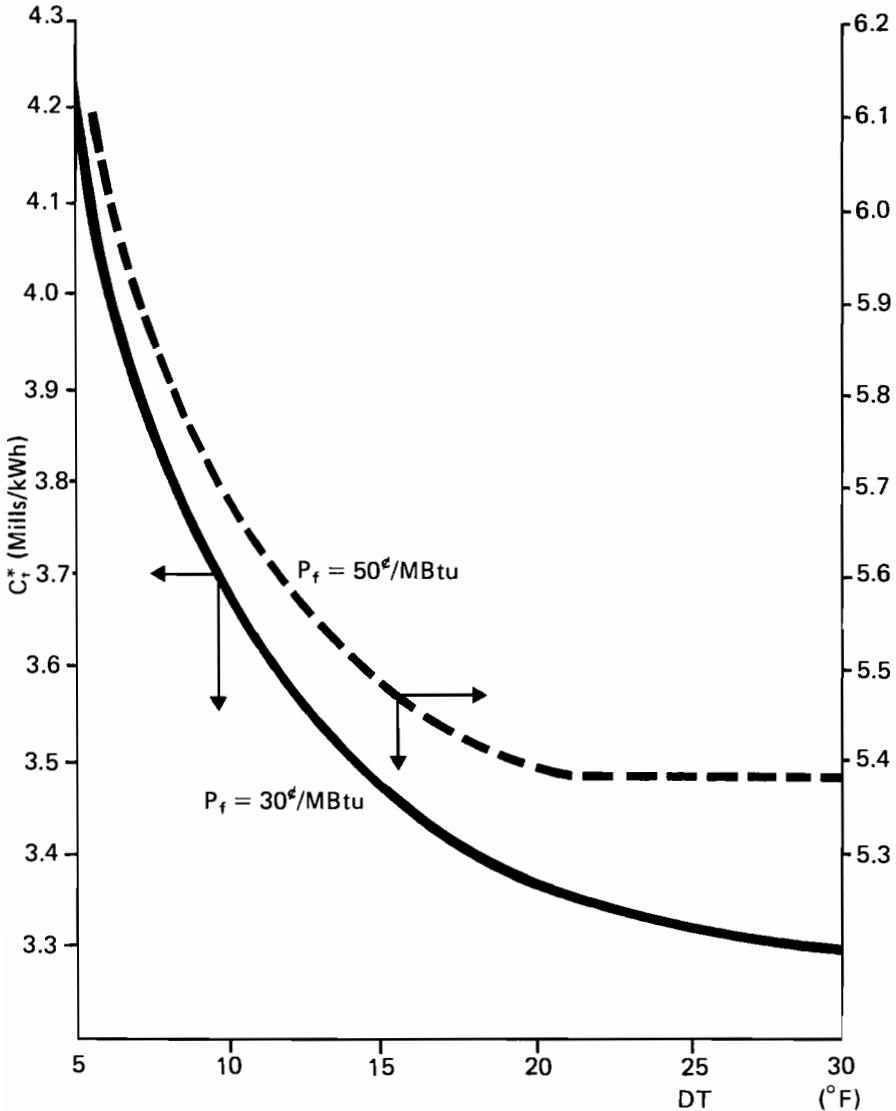

FIGURE 16.1 Trade-off relation between minimum generating cost C_t^* and cooling-water temperature differential DT .

cooling water on the economic status of a steam power plant with once-through cooling system is clearly shown.

16.3 A PROCEDURE IN GROUP DECISION

The aim of traditional optimization is to find a solution x^* that affords a minimum to a single objective function $f(x)$. This is equivalent to finding a state "nearest" to the ideal point $\hat{f} = \inf f(x)$. Similarly, the aim of some multicriteria optimization is considered to be the identification of a state "nearest" to the ideal point $\hat{F} = \inf F(x) = (\inf f_1(x), \inf f_2(x), \dots, \inf f_r(x))^T$, where $F = (f_1, f_2, \dots, f_r)^T$. What, then, does "nearest" mean?

The concept of "near" is akin to that of distance. In mathematics, there are many kinds of distance. Most multicriterion problems define distance by using the vector ρ_0 , where

$$\rho_0(F(x), \hat{F}) = (|f_1(x) - \hat{f}_1|, |f_2(x) - \hat{f}_2|, \dots, |f_r(x) - \hat{f}_r|) \quad (16.4)$$

and $F(x)$ is a state and \hat{F} is the ideal point. However, by using the vector ρ_0 , we cannot usually specify a unique solution, but a minimal solution set (Pareto optimal solutions) can be generated. Distance may be introduced by using the decision makers' value judgements so that a unique solution may be chosen. It is Minkowski's p -metric

$$\rho_p(F(x), \hat{F}) = \left(\sum_{i=1}^r w_i |f_i(x) - \hat{f}_i|^p \right)^{1/p} \quad (16.5)$$

that is most often used in a wide class of practical problems. Here, w_i ($i = 1, \dots, r$) are weighting coefficients and the parameter p balances between the criteria. Decision makers may define parameters w_i and p by their own preferences and reconciliation between these preferences (Nakayama and Sawaragi, 1975).

Based on (16.5), a kind of social welfare function can be determined. Decision makers must fully comprehend the special feature of each social welfare function and use it suitably according to the situation. For example, using $p = 1$ in the p -metric, the trade-off ratio at the solution x^* , which minimizes ρ_1 , is given by

$$(df_i/df_j)_{x=x^*} = -w_j/w_i. \quad (16.6)$$

On the other hand, for $p = \infty$, the ratio of values between $f_i(x^*)$ and $f_j(x^*)$ is given by

$$f_i(x^*)/f_j(x^*) = w_j/w_i. \quad (16.7)$$

In other words, the social welfare function for $p = 1$ regards the trade-off ratio between each criterion as important, and, as p increases, the corresponding social welfare function emphasizes the ratio of values between criteria rather than the trade-off ratio. If decision makers want both the trade-off ratio and the ratio of

values at the desired levels, the following form is appropriate:

$$SW = f_1^{w_1} \cdot f_2^{w_2} \cdot \dots \cdot f_r^{w_r}. \quad (16.8)$$

In this type of social welfare function, the relation between the trade-off ratio and the ratio of values is given by

$$(df_i/df_j)_{x=x^*} = -(w_j/w_i) \cdot f_i(x^*)/f_j(x^*). \quad (16.9)$$

Nash's method for dealing with bargaining problems is based on a special form of (16.8).

16.4 URBAN PLANNING

The Systems Development Laboratory of Hitachi, Ltd. (Kozawa, 1974; Hitachi, 1972, 1973), has considered policymaking in urban planning from the point of view of a decision-making problem in the urban administration system. The study, which lasted from 1971 to 1973, was designed to allow the inclusion in decision making of evaluations of the public's feelings about the quality of urban life.

They began the development of a model that quantitatively evaluates the quality of urban life based on the citizen's perception by using the hierarchical urban program structure and worth function. The hierarchy of worth structure for urban systems is constructed as in Figure 16.2; the worth imputed for the lowest item is then defined as the worth function of the selected urban attribute. To do this, citizen satisfaction is classified into the following three patterns:

$$S = k(P - P_0)$$

$$S = k \log P/P_0$$

$$S = S_0 \text{EXP} [k(P - P_0)]$$

where S and P denote the degree of satisfaction and the level of the performance, respectively. Some 33 functions $S = f(P)$ are established on the basis of the above three patterns, and a best fit function among them is selected by the least-square method applied to data on citizen information derived through use of a questionnaire. The worth function $W = W(P)$, whose range is from 0.0 (at the lowest level of admissible performance) to 1.0 (at the satisfactory level), is then obtained using one of several methods, such as (a) a scale transformation for the obtained satisfaction function (e.g., the time it takes children to go from the house to the playground); (b) econometric methods (e.g., worth function of income); and (c) a method using a proxy index for worth (e.g., response times for emergency medical services).

Next, each worth function is weighted so that a social welfare function may be determined. The weights for items at the lowest level are established by normalizing the factor loading, which is obtained by the principal component analysis applied to the questionnaire data on citizen information. In this example, the weights at

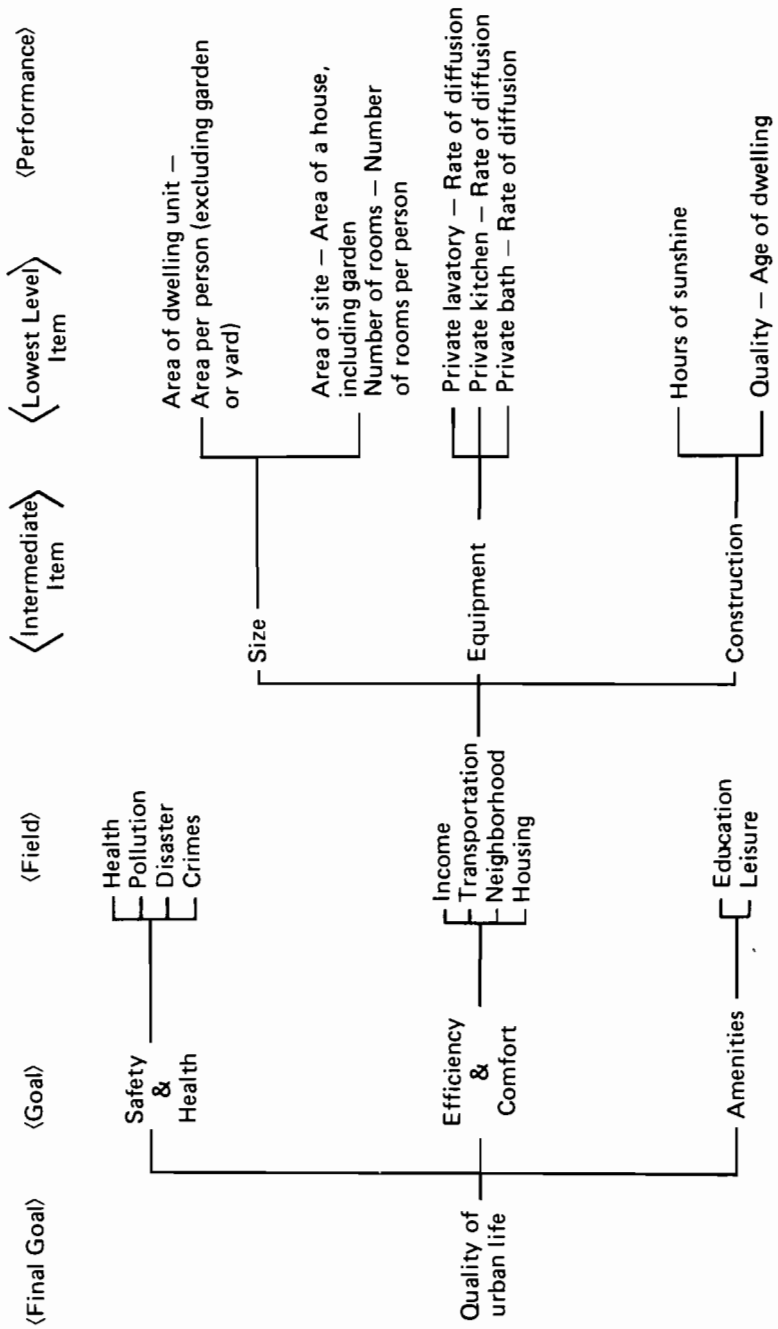

FIGURE 16.2 Hierarchical worth structure (partial).

higher levels of the hierarchical worth structure are based on the judgment of decision makers or administrators.

Finally, the social welfare function is amalgamated as a linear combination of all worth functions with the weights obtained above. The decision makers determine their policy adaptively by observing the outputs from the social welfare function. Several experiments were made for seven plans; among them were plans for installation of sewerage and for siting of roads and parks.

16.5 CONCLUSION

Assessment of the environment has become a most important theme. In light of this, Hitachi's project suggests ways of controlling environmental pollution. Since the environmental system inevitably has multiple objectives, or multiple attributes, we believe that decision making with multiple objectives offers the most promising tool for solution of environmental problems. Especially since decision making in environmental or urban design requires citizen consensus, there is a need for effective methodologies for public decision.

REFERENCES

- Hitachi Research and Development for Over-all Urban Management Systems, Report (1) Urban Management System; Foundation: Institute for Local Administration Systems, Institute for Systems Development, Hitachi Manufacturing Co., Inc., Tokyo, 1972.
- Hitachi Research and Development for Over-all Urban Management Systems, Report (1) Development of Urban Management System Model. Systems Development Laboratory, Hitachi, Ltd., Tokyo, 1973.
- Inoue, K., E.J. Henley, C.H. Otto, and R.G. Thompson. 1974. Water use policies and power plant economics. In *Proceedings of the American Power Conference*. Vol. 36. Illinois Institute of Technology, Chicago, pp. 767-771.
- Kozawa, K. 1974. Development of the evaluation model for the citizen consciousness on the urban administration. (In Japanese.) *Behaviormetrics*, Vol. 1, pp. 11-21.
- Nakayama, H., and Y. Sawaragi. 1975. Scalarization techniques for multicriteria optimization and a procedure in group decision. (In Japanese.) In *Proceedings of Systems Symposium*. Society of Instrument and Control Engineering, Tokyo, pp. 249-254. (English version is in preparation.)
- Nakayama, H., H. Sayama, and Y. Sawaragi. 1975a. A generalized lagrangean function and multiplier method. *Journal of Optimization Theory and Applications*, Vol. 17, pp. 211-227.
- Nakayama, H., H. Sayama, and Y. Sawaragi. 1975b. Multiplier method and optimal control problems with terminal state constraints. *International Journal of Systems Science*, Vol. 6, pp. 465-477.
- Sayama, H., Y. Kameyama, H. Nakayama, and Y. Sawaragi. 1974. Multiplier method for non-linear programming problems. (In Japanese.) *Transactions of the Society of Instrument and Control Engineering*, Vol. 10, pp. 28-35.

DISCUSSION

KULIKOWSKI: How did you determine the weights for each worth function in the social welfare function?

NAKAYAMA: The weights were based on the data gathered from citizens through questionnaires.

RAIFFA: That's in the second example. In the first one concerning thermal pollution, was it also done that way?

NAKAYAMA: With the thermal pollution, we haven't decided the weights. We were just concerned with describing the feasibility trade-offs.

RAIFFA: I'd like to make a brief remark concerning your ideal point introduced in section 16.3. It seems that you specify some distance measure and try to find the point in the efficient set that is closest to the ideal using this measure. With such a procedure, you have to be very careful about units of measurement, because distance is not invariant to changes in these units of measurement.

17 Alternative Formulations for a Trajectory Selection Problem: The Mariner Jupiter/Saturn 1977 Project

James S. Dyer and Ralph F. Miles, Jr.

17.1 INTRODUCTION

This paper presents several formulations of a planetary trajectory selection problem, a problem that may be viewed alternatively as a bargaining problem, as a social welfare maximization problem, or as a single-decision-maker problem with multiple attributes. Both the theoretical and practical implications of these formulations are discussed. These formulations are then applied to a trajectory selection problem for the Mariner Jupiter/Saturn 1977 (MJS77) Project (Schurmeier, 1974). This application is summarized here, and additional details may be found in Dyer and Miles (1976, 1977).

Two MJS77 spacecraft will be launched by the National Aeronautics and Space Administration (NASA) in August and September 1977 on trajectories that will swing by Jupiter in 1979, encounter Saturn in late 1980 or 1981, and then escape the solar system. Funding for the MJS77 Project is in excess of \$300 million, and the Project is managed for NASA by the Jet Propulsion Laboratory (JPL) of the California Institute of Technology. NASA has selected some 80 scientists, divided by specialization into 11 science teams, to participate on the MJS77 mission. The scientists interface with the Project through a Science Steering Group (SSG) composed of the team leaders of the science teams. At the time these trajectories were selected, 10 of the 11 science teams had been chosen.

The selection of the trajectories for the mission is a major Project decision, since the trajectory characteristics will significantly affect the scientific investigations. At a meeting on October 22 and 23, 1973, a pair of trajectories was

We acknowledge the efforts of the many people who have contributed to the MJS77 trajectory pair selection process: the scientists participating on the MJS77 science teams, the JPL science team representatives, the trajectory analysts and computer programmers of the Mission Analysis Division of JPL, and the members of the MJS77 Project Office. This work represents one phase of research conducted at the Jet Propulsion Laboratory for the National Aeronautics and Space Administration under Contract NAS 7-100.

selected and recommended by the SSG for incorporation as the Project standard trajectory pair. While this trajectory pair may not actually be flown, it nevertheless represents a commitment by the scientists, because the Project systems will be designed to this standard trajectory pair. Thus the selection of the standard trajectory pair was viewed as an important milestone, both by the Project and by the scientists.

17.2 ALTERNATIVE FORMULATIONS

An analysis was performed before the October meeting of the SSG to facilitate selection of the trajectory pair. The trajectory selection problem can be viewed as a bargaining problem, as a social welfare maximization problem, or as a single-decision-maker problem with multiple attributes. Each of these alternative viewpoints was employed in the analysis. For each viewpoint we shall present and criticize one or more alternative problem formulations. While we do not discuss all the viewpoints and alternative formulations corresponding to each viewpoint, those that we have chosen are representative of the available solution concepts.

17.2.1 A BARGAINING PROBLEM

Formally, the Project Manager has the final responsibility for the selection of the trajectory pair for the two MJS77 spacecraft. Nevertheless, subject to the technological and astrodynamical limitations on the spacecraft, this trajectory should be selected so that it satisfies the science requirements of each of the science teams. Therefore, the evaluation process for the trajectory pairs should consider the needs of the scientists rather than of the Project Manager.

The relationship between the scientists and the Project provides additional justification for this point of view. The scientists who participate in these planetary missions are the same people who testify in congressional budget hearings in support of the missions; since scientific support is required to obtain funding for these missions, the Project management has a stake in maintaining the goodwill of the scientists.

According to this viewpoint, it is inappropriate to conclude that the scientists are subordinate to the Project Manager. At times, it is more appropriate to view the Project Manager as assisting the scientists in the role of an arbitrator whose task is to reconcile conflicts among the teams over scientific objectives. Therefore the Project Manager should seek some arbitration scheme to aid in selecting the final trajectory pair. Among the problem formulations that provide such arbitration schemes are bargaining models from cooperative game theory.

A Bargaining Model Formulation

The trajectory selection problem may be viewed as a finite, n -person game, in this case with the teams corresponding to players so that $n = 10$. This definition assumes

that any internal organizational problems within a team have been accounted for, so that the team "speaks with one voice" (see Shapley and Shubik, 1974). This latter assumption is appropriate, since from the perspective of the Project, the science teams are viewed as individual entities. Subject to certain policies and constraints defined by the Project, the science teams are relatively autonomous. Conflicts and disputes that might arise within teams are to be settled by the team members without Project intervention.

A pure strategy t_k^i for player (team) i is selected from the set T^i of technologically and astrodynamically feasible trajectory pairs. Although there are in fact an infinite number of feasible trajectory pairs, in practice only a finite number of trajectories will be considered, and there is no significant theoretical loss in restricting T^i to be a finite set of m trajectory pairs representative of the infinite set and requiring $t_k^i = t_k^j$ for all $i, j \in \{1, \dots, 10\}$ and $k = 1, \dots, m$. Thus, the set of pure strategies will be identical for each team, and the player superscript i can therefore be omitted for the strategy t_k and the set T .

We scale the utility function of each team so that $u^i = 0.0, i = 1, \dots, 10$, when we obtain no useful information for team i . Such a situation could arise, for example, if the trajectory pair were chosen so that the instruments associated with an experiment could not function, or if the mission were canceled. We also define $u^i = 0.0, i = 1, \dots, 10$, if the teams do not agree on a trajectory pair, since they must eventually agree on (or accept) the same solution. Failure to reach agreement would be tantamount to canceling the mission as it is now defined; as a result, no useful information would be obtained by any team.

One solution for this n -person game is provided by the Nash bargaining model (1950) as generalized to the n -person case by Harsanyi (1959). In this model, the convex, compact bargaining set $U \subseteq R^n$ represents the set of all payoff vectors $u = (u^1, \dots, u^n)$, which can be obtained by the joint action of the players. That is, U includes both the payoff vectors resulting from actual bargains and those resulting from randomizations among bargains. The payoff vectors are expressed in terms of the utility functions of the n players. Any bargaining situation is characterized by both the bargaining set and the status quo point $u_* = (u_*^1, \dots, u_*^n)$, which represents the situation where no bargain takes place. Therefore, a bargaining situation is denoted by $[U, u_*]$.

The arbitration scheme proposed by Nash requires the determination of the point \bar{u} that maximizes

$$\prod_{i=1}^n (u^i - u_*^i),$$

subject to $u \in U$ and $u \geq u_*$. This solution \bar{u} is unique, and it is the only solution that satisfies Nash's four axioms of "fairness."

The n -person game formulation of the trajectory selection problem is appropriate for use with the Nash bargaining model. The payoff vector of zeros associated with failure to reach an agreement becomes the status quo point in the Nash model.

Since the status quo point represents the situation where no bargain takes place, we can set $u_* = (0, \dots, 0)$ without requiring knowledge of the trajectory initially desired by each team.

A Critique

A critique of the use of the Nash bargaining model for the trajectory selection problem is provided by Bonnardeaux *et al.* (1976). They conclude that the four Nash axioms that characterize a solution are acceptable rules of arbitration for this problem. However, they question the practical usefulness of a randomized solution that could result from the application of the Nash model.

As an alternative, they recommend the use of the restricted bargaining set U' consisting only of the payoff vectors $u = (u^1, \dots, u^n)$ that result from actual bargains. The multiplicative collective choice rule they propose is the determination of the trajectory pair $t_k \in T$ that maximizes

$$\prod_{i=1}^{10} u^i(t_k). \quad (17.1)$$

This latter formulation does provide a solution that may violate one of the four Nash axioms (symmetry), but this can be justified via the argument of Zeuthen (see Harsanyi, 1956). For further details, see Bonnardeaux *et al.* (1976).

Another issue of concern is the simplistic view of the payoff vector associated with failure to reach agreement, which becomes the important status quo point in the Nash model. In reality, if no agreement were reached, the Project Manager would resolve the problem. He might impose a solution hitherto unknown to the science teams, or he might require a fundamental redesign of the mission. The latter could actually result in the removal of some science teams from the mission in order to achieve a more compatible set of experiments. This situation complicates any attempt to model the bargaining problem because the failure to reach agreement actually corresponds to a different probability distribution over all feasible trajectory pairs for each team. It is difficult to assess how seriously the simplifying assumptions regarding the status quo distort the solution to the Nash model.

17.2.2 A SOCIAL WELFARE MAXIMIZATION PROBLEM

The argument that the evaluation process for the trajectory pairs should be directed toward the scientists is a persuasive one. At issue is the appropriate role of the Project Manager. According to the viewpoint that justified a bargaining model, the Project Manager assumed the role of an arbitrator. Certainly, other possibilities exist.

For example, the Project Manager may define the technological and astrodynamical constraints on the trajectories and work with the scientists to develop feasible candidate trajectory pairs. Having done this, he may play no other role in

the selection of the final trajectory. Keeney (1976) calls this the participatory group problem, wherein the scientists themselves must actually generate the rule for aggregating the preferences of the science teams in order to select an alternative. In another approach, the Project Manager may take a more active role and serve as a "benevolent dictator" who imposes the rule for aggregating team preferences.

In either case, the trajectory selection problem is viewed as an n -person social welfare maximization problem, with the teams corresponding to individuals so that $n = 10$. This formulation also assumes that each team speaks with one voice. Alternative formulations of this problem allow the use of both ordinal and cardinal expressions of preference by the individuals (teams) within the group.

Formulation with Ordinal Data

The science teams must rank, in order of decreasing preference, the set T of m technologically and astrodynamically feasible trajectory pairs. There are two preference aggregation rules commonly used with ordinal rankings such as these.

The rank sum rule is one of the oldest and most widely used preference aggregation rules. It requires the calculation of the mean ordinal rank for each trajectory pair, with the trajectory pair achieving the lowest mean rank being preferred. It is a slight variation of the Borda method, in which each individual assigns a "mark" to the n alternatives (ranked from worst to best) of $0, 1, \dots, n - 1$, and the winner is the alternative receiving the largest total number of marks (Fishburn, 1971).

Also often used is the majority decision rule, or the Condorcet rule (Fishburn, 1971, 1973). According to this rule, an alternative with a strict simple majority over each of the other alternatives should be the social choice. This rule requires that the alternatives be compared pairwise in order to determine the majority winner in each case.

Formulations with Cardinal Data

The additive social welfare function defined on cardinal utility function values can be written in the general form

$$C(t_k) = \sum_{i=1}^{10} \lambda^i u^i(t_k), \quad (17.2)$$

where $t_k \in T$ denotes a particular trajectory pair, and λ^i is a weighting factor for the i th science team. Alternate sets of sufficient conditions for an additive social welfare function have been given by Harsanyi (1955) and Keeney and Kirkwood (1976). We found these conditions to be persuasive in our case, so the additive form (17.2) was used in the analysis.

There still remains the difficult problem of making interteam utility comparisons. To do this requires consideration of the related issues of interteam normalization through the scaling of each science team's utility function and the choice of

the λ^i 's, the weighting factors. Discussions of the practical importance of making interpersonal (interteam) utility judgments are provided by Rapoport (1975) and Shapley and Shubik (1974).

First let us consider the problem of interteam normalization. Suppose we arbitrarily scale each u^i so that

$$\text{maximum}_{t_k \in T} u^i(t_k) = 1.0 \quad (17.3)$$

and

$$\text{minimum}_{t_k \in T} u^i(t_k) = 0.0 \quad (17.4)$$

where t^{i*} and t_*^i solve (17.3) and (17.4), respectively. Ideally, we would like the "utility differences" between $u^i = 1.0$ and $u^i = 0.0$ to be the same for each team (see Suppes and Winet, 1955). This means that we must explicitly recognize the magnitudes or intensities of the anticipated gains or losses in preference. This might be partially accomplished by ensuring that the trajectory pairs t^{i*} and t_*^i , respectively, determine similar consequences for each team.

A similar consequence for $u^i(t_*^i)$ could be created by using the same strategy employed in the definition of the status quo point for the Nash bargaining model. That is, a "no-data" trajectory pair could be included in T . This no-data pair would obviously be considered the worst alternative (t_*^i) by each team.

It is more difficult to ensure that the consequence associated with t^{i*} is the same for each team, since the feasible trajectory pairs are constrained by technological and astrodynamical considerations. However, by allowing each team to suggest trajectory pairs for inclusion in T , we can guarantee that there is at least one pair $t^{i*} \in T$ that is "very good" for team i , since experiments that would be incompatible with the mission constraints were eliminated from consideration in the early phases of the mission design. To this extent, an attempt can be made to equate the magnitude of the preference difference between t^{i*} and t_*^i for each team.

The λ^i 's can be chosen to compensate for imbalances in the perceived magnitudes of the preference differences in similarly scaled u^i functions. However, we have chosen a scaling procedure for the u^i 's that should eliminate any such imbalances. The λ^i 's can also be used to ensure that the preferences of some teams are favored over those of others because their associated experiments are "more important."

Neither NASA nor the scientists would claim that the different science investigations are "equally valuable." Great differences actually exist among the resources (dollars, weight, and power) allocated to the various science investigations, which implies differences in value. However, the task of specifying differential weighting factors, λ^i 's, would be an extremely divisive one for the group (the SSG). One of the guidelines for the trajectory selection process explicitly stated by the Project Manager was that it should not create dissension among the members of the SSG. The SSG preferred to assume that all of the experiments were equal, implying that $\lambda^i = \lambda^j$ for all teams i and j . Clearly, any differential weights would have to be assigned by the Project Manager in his role as a benevolent dictator.

A Critique

The difficulties with the rank sum and majority decision rules based on ordinal data are well known. To summarize briefly, the results of using the rank sum rule can be modified by irrelevant alternatives. The application of the majority decision rule does not always provide a weak ordering due to cyclic results. Neither of these rules considers the strength of preference of individuals. For further discussion, see Sen (1970) or Fishburn (1971).

The advantages of these two rules are that they are easy to understand and easy to operationalize. Ranking of alternatives is relatively easy and noncontroversial task, even for science teams considering such complex alternatives as trajectory pairs.

The conditions justifying the additive social welfare function based on cardinal data are theoretically appealing. The difficulty lies in operationalizing the collective choice rule. The first concern is the appropriate choice of the scaling procedure for the individual utility functions (the u^i 's) and the related issue of selecting the weights (the λ^i 's).

In the trajectory selection problem, the choice of t^{i*} and t_*^i attempts to provide a scaling of the u^i 's with approximately equal magnitudes of preference difference for each team. However, the SSG prefers to assume that all of the λ^i 's are equal to avoid the difficult problem of specifying unequal weights, even though the scientists would not actually claim that the experiments are "equally valuable." The Project Manager would be reluctant to assign unequal λ^i weights because of the supporting relationship between the scientists and the Project.

Another concern is the possibility that the individual team utility functions are erroneous. This could result from errors caused by a difficulty in understanding the cardinal utility function assessment procedure, by a lack of effort in accurately evaluating the candidate trajectory pairs, or by deliberate misrepresentation of preferences in an attempt to influence the results.

17.2.3 A SINGLE-DECISION-MAKER PROBLEM WITH MULTIPLE ATTRIBUTES

When does a "benevolent dictator" become a single decision-maker treating the utility functions of individuals as attributes? The difference between these two cases is not substantial.

In the trajectory selection problem, the Project Manager may agree that the evaluation process should be based on the preferences of the scientists. However, this need only imply that these preferences are the appropriate criteria on which he should base *his* decision, not that the scientists should actually make the decision. After all, the final responsibility for the selection of the trajectory pair is his, so it also seems appropriate to expect him to make the decision.

Formulation

Since the Project Manager views the preferences of the science teams as the appropriate criteria for his decision, the set of relevant consequences is *not* the set of feasible trajectory pairs T . Rather, it is identical to the restricted bargaining set of the "payoff vectors" $u = (u^1, \dots, u^{10})$ associated with the trajectory pairs in T .

Various forms of multiattributed utility functions have been proposed (e.g., see Fishburn, 1974; Keeney, 1974; and Farquhar, 1975), but the simplest form to operationalize is additively separable in the criteria. For the trajectory selection problem, such a utility function may be written as

$$v(u^1, \dots, u^{10}) = v^1(u^1) + v^2(u^2) + \dots + v^{10}(u^{10}), \quad (17.5)$$

where $v^i(u^i)$ is a utility function of the Project Manager defined on the utility function of science team i .

Debreu (1960) presents conditions that permit the use of the additively separable utility model under certainty. However, the associated assessment procedures are cumbersome. We prefer to justify (17.5) on the basis of Fishburn's "marginality conditions" (Fishburn, 1970), which allow the additive utility function to be written in the convenient form

$$v(u^1, \dots, u^{10}) = \lambda^1 f^1(u^1) + \lambda^2 f^2(u^2) + \dots + \lambda^{10} f^{10}(u^{10}), \quad (17.6)$$

where $f^i(u^i)$ is a utility function scaled from 0 to 1 and λ^i is a scaling factor or "weight" for the i th criterion.

Note that if v^i in (17.5) or f^i in (17.6) is a positive linear transformation of u^i , then (17.5) or (17.6) is equivalent to the additive social welfare function (17.2). Therefore, we would expect the conditions justifying (17.5) and (17.6) to be very similar to those which justify (17.2), and that is indeed the case.

Fishburn (1970) has shown that $v(u^1, \dots, u^{10})$ may be evaluated by an additive utility function if the desirability of any lottery from the viewpoint of the Project Manager depends only on the marginal probability distributions of the u^i 's and not on their joint probability distributions. That is, if the marginal probability distributions for each u^i are identical in two different lotteries, then the decision maker must be indifferent between the two lotteries.

If the marginal probability distributions for u^i are the same in two lotteries, then the expected value of u^i is the same for the two lotteries. Since u^i is the utility function of the i th science team, that science team would also be indifferent between the two lotteries. This marginality requirement is satisfied if the decision maker subscribes to the following condition: if two alternatives are indifferent from the standpoint of each individual, then they are indifferent for the group as a whole. Harsanyi (1955) uses this condition, plus the assumptions that the social welfare function and the utility function of the science teams obey the von Neumann-Morgenstern axioms of utility theory, to obtain a linear social welfare function (17.2).

Using the convenient additive form (17.6), if f^i is not a positive linear transformation of u^i , then the Project Manager may take decisions that are not consistent with the preferences of the science teams. On the basis of our previous arguments, this may seem undesirable. However, there may be instances in which the Project Manager might wish to impose such transformations.

The u^i function reported by the i th science team may not accurately reflect its preferences because of deliberate or unrecognized errors. The Project Manager may choose to adjust the reported values [imposing some function $f^i(u^i)$] so that the results are more consistent with his own expectations and beliefs. In such a case, $f^i(u^i)$ will be a surrogate for the "theoretical u^i ." Alternatively, the Project Manager may choose to modify the u^i reported by a team because he considers their implied level of risk aversion to be unacceptable, even though he believes it faithfully represents the actual preferences of science team i .

The problem of specifying the values of the λ^i 's is the same as if (17.6) were the additive social welfare function.

A Critique

The major concern with this viewpoint of the trajectory selection problem as a multiattribute problem is the Project Manager's reluctance to take an active role in the decision process. He would prefer to have the recommendation of the trajectory pair made by the scientists. However, he may wish to maintain the option of modifying the utility functions *reported* by the teams [define $f^i(u^i)$] or of assigning the weights (the λ^i 's) in some instances.

To see some implications of the additive formulation, suppose that there are only two science teams on the Project. The additive formulation (17.5) implies that the Project Manager would be indifferent between a 50–50 chance of either $u^1 = 1$ and $u^2 = 0$ or $u^1 = 0$ and $u^2 = 1$, and a 50–50 chance of either $u^1 = 1$ and $u^2 = 1$ or $u^1 = 0$ and $u^2 = 0$. That is, he would be indifferent between launching the mission knowing that one of his experiments would fail and the other would work perfectly and launching the mission with a 50–50 chance that both experiments would work perfectly.

In discussions of social choice, it is often suggested that the latter alternative "should" be preferred since it is more equitable: both science teams receive the same result. In the case of the trajectory selection problem, it seems more likely that the Project Manager would prefer the former alternative, which at least guarantees some success on the mission. Thus, in certain situations, the additive model may not be appropriate, and one would need to revert to an alternative model, perhaps of the form of Keeney's multiplicative utility formulation (1974).

17.2.4 THE CHOICE OF THE ALTERNATIVE FORMULATIONS

The purpose of an analysis is seldom to determine a solution. Rather, the purpose is to provide information to the decision maker. Thus, there may be no compelling

reason to select one of these alternative formulations as *the* appropriate one for the trajectory selection problem, or to be concerned if several formulations produce different rankings of the alternatives. As we have seen, each of these formulations is based on a set of assumptions that supports one viewpoint of this complex problem, but no single formulation is compatible simultaneously with the richness of viewpoints associated with a complex, real-world problem involving many individuals.

Shapley and Shubik (1971) note that numerous solution concepts have been proposed for n -person games by many different authors.

Each solution, in its own fashion, seeks to probe into some aspect of societal rationality – i.e., the possible, proposed, or predicted behavior of rational individuals in mutual interaction. But all of them have to make serious compromises. Inevitably, it seems, sharp predictions or prescriptions can be had only at the expense of severely specialized assumptions about the customs or institutions of the “society” being molded. The many intuitively desirable properties that a solution ought to have, taken together, prove to be logically incompatible. A completely satisfying solution is rarely obtained by any single method of attack on a multiperson competitive situation. . . .

In this spirit, we selected nine different collective choice rules for use in the analysis of the trajectory selection problem for the MJS77 Project. Each of these collective choice rules is compatible with one or more of the alternative viewpoints of this problem, and each alternative viewpoint is represented by at least one rule.

17.3 THE MJS77 TRAJECTORY SELECTION PROCESS

The trajectory selection process required the JPL engineers to develop, in collaboration with the science teams, a large set of trajectories that spanned the range of scientifically attractive alternatives. Through negotiations within the SSG, 32 candidate trajectory pairs were selected and presented to the science teams for evaluation. The evaluations by the science teams were then analyzed by JPL within the context of the alternative theoretical formulations presented in the preceding section. The science team evaluations and the results of the analysis were then presented to the SSG at a meeting on October 22 and 23, 1973. The final trajectory recommendation was made by the SSG and approved by the Project Manager.

17.3.1 THE SCIENCE TEAM EVALUATIONS

As the first step in the trajectory pair evaluation, the science teams were requested to rank, in order of decreasing preference, the set T of 32 candidate trajectory pairs. The next part of the instructions presented the procedure for determining the preferences of the science teams on a cardinal scale of measurement. This cardinalization was attained through the use of von Neumann–Morgenstern lotteries (von Neumann and Morgenstern, 1947).

The utility function values were generated in a two-step process. For the cardinalization of preferences between trajectory pairs, each trajectory pair t_k was compared to a lottery between the most preferred and least preferred trajectory pairs. The i th science team was requested to assign a probability number p_k^i such that it was indifferent between the certain receipt of the trajectory pair t_k and the lottery that yielded its most preferred trajectory pair t^{i*} with probability p_k^i or its least preferred trajectory pair t_l^i with probability $1 - p_k^i$. In this manner, each of the 10 science teams generated 32 probability numbers p_k^i , one for each of the 32 trajectory pairs.

As we have noted, the additive collective choice rule requires that interteam utility comparisons be made. To accomplish this, the utility scales need to be adjusted to compensate for differences in the relative strength of preference between the least preferred trajectory pair and the most preferred trajectory pair for each team.

For this normalization, each of the science teams was requested to state a probability number p_l^i such that it was indifferent between the certain receipt of its least preferred trajectory pair t_l^i and the lottery that yielded its most preferred trajectory pair t^{i*} with probability p_l^i or a no-data trajectory pair t_* with probability $1 - p_l^i$. In the instructions, the no-data trajectory pair t_* was called the "Atlantic Ocean Special," in remembrance of the flight of Mariner 8, which terminated abruptly in the Atlantic Ocean.

By setting $u^i(t^{i*}) = 1.0$ and $u^i(t_*) = 0.0$, the teams obtain $u^i(t_l^i) = p_l^i$. The formula for calculating the utility function values for the trajectory pairs thus becomes

$$u^i(t_k^i) = p_k^i + (1 - p_k^i) p_l^i.$$

This two-step process was used to generate the utility function values because of a concern that some science teams would be so risk-averse to a lottery with the no-data trajectory pair that either these science teams would be unable to discriminate among the trajectory pairs intermediate in preference, or they would refuse to participate in the lottery process. This concern was well founded, as the subsequent analysis will show.

The no-data trajectory pair was also identified as the status quo point in the Nash bargaining model formulation of the trajectory selection problem. Therefore, this normalization also provides utility function values that can be used in the multiplicative collective choice model.

The science teams were given approximately 1 month to carry out this procedure. The ordinal rankings and the cardinal utility function values that resulted are shown in Table 17.1. The acronyms at the tops of the columns identify the ten science teams, which are described in Dyer and Miles (1976, 1977).

Several science teams were extremely risk-averse. The MJS77 Project will last about 10 years and may be the only foreseeable opportunity for some of these scientists to be involved in a planetary mission. Given this situation, it was very

TABLE 17.1 Science Team Ordinal Rankings and Cardinal Utility Function Values^a

Trajectory Pair	RSS		IRIS		ISS		PPS		UVS		CRS		LECP		MAG		PLS		PRA	
	Rank	Utility	Rank	Utility	Rank	Utility	Rank	Utility	Rank	Utility	Rank	Utility	Rank	Utility	Rank	Utility	Rank	Utility	Rank	Utility
1	6.0	0.772	28.0	0.871	13.5	0.850	22.0	0.550	17.0	0.820	24.5	0.850	14.0	0.700	15.0	0.500	26.5	0.600	19.0	0.546
2	6.0	0.772	24.5	0.875	22.0	0.750	25.0	0.530	22.0	0.790	5.5	0.910	7.0	0.830	19.0	0.480	11.0	0.750	18.0	0.547
3	20.5	0.600	14.5	0.925	4.0	0.960	28.5	0.520	5.0	0.910	28.5	0.840	28.0	0.450	27.5	0.350	7.0	0.900	24.0	0.109
4	20.5	0.600	6.0	0.948	26.0	0.700	20.0	0.570	2.0	0.970	28.5	0.840	27.0	0.480	26.0	0.351	7.0	0.900	25.0	0.108
5	20.5	0.600	9.0	0.943	28.5	0.670	17.0	0.600	4.0	0.920	13.0	0.880	6.0	0.900	6.0	0.800	1.5	1.000	6.0	0.600
7	20.5	0.600	32.0	0.750	32.0	0.600	32.0	0.600	18.0	0.810	32.0	0.800	30.0	0.430	25.0	0.360	26.5	0.600	26.0	0.107
8	20.5	0.600	20.0	0.886	10.0	0.900	5.0	0.780	13.5	0.830	21.0	0.860	11.0	0.740	7.0	0.700	17.5	0.700	9.0	0.556
9	20.5	0.600	12.0	0.930	16.0	0.800	13.0	0.650	26.0	0.760	9.5	0.890	19.0	0.610	16.0	0.490	17.5	0.700	13.0	0.552
10	3.0	0.887	11.0	0.935	4.0	0.720	8.5	0.720	19.5	0.800	2.0	0.960	20.0	0.600	24.0	0.400	17.5	0.700	7.0	0.558
11	20.5	0.600	13.0	0.928	7.0	0.920	3.5	0.810	28.5	0.720	5.5	0.910	26.0	0.490	31.0	0.260	32.0	0.500	27.0	0.106
13	8.0	0.652	18.0	0.915	22.0	0.750	28.5	0.520	13.5	0.830	31.0	0.810	31.0	0.320	30.0	0.280	26.5	0.600	28.0	0.105
15	3.0	0.887	29.5	0.869	16.0	0.800	18.5	0.580	9.0	0.840	17.5	0.870	16.0	0.650	20.0	0.430	11.0	0.750	22.0	0.543
17	20.5	0.600	4.0	0.966	13.5	0.850	6.5	0.750	13.5	0.830	24.5	0.850	9.0	0.770	14.0	0.510	17.5	0.700	8.0	0.557
18	20.5	0.600	8.0	0.944	10.0	0.900	15.0	0.630	22.0	0.790	13.0	0.880	24.0	0.560	17.5	0.485	26.5	0.600	29.0	0.104
19	20.5	0.600	26.5	0.873	10.0	0.900	28.5	0.520	26.0	0.760	13.0	0.880	25.0	0.500	29.0	0.300	26.5	0.600	30.0	0.103
20	6.0	0.772	10.0	0.937	31.0	0.620	22.0	0.550	32.0	0.630	21.0	0.860	22.0	0.580	27.5	0.350	26.5	0.600	16.0	0.549
21	20.5	0.600	14.5	0.925	3.0	0.970	31.0	0.510	22.0	0.790	28.5	0.840	29.0	0.440	11.0	0.575	7.0	0.900	31.0	0.102
22	20.5	0.600	29.5	0.869	10.0	0.900	18.5	0.580	31.0	0.640	5.5	0.910	17.0	0.630	23.0	0.405	26.5	0.600	23.0	0.542
23	20.5	0.600	24.5	0.875	16.0	0.800	25.0	0.530	30.0	0.670	5.5	0.910	8.0	0.780	22.0	0.408	26.5	0.600	20.0	0.545
24	3.0	0.887	17.0	0.919	26.0	0.700	28.5	0.520	1.0	1.000	28.5	0.840	32.0	0.300	32.0	0.250	26.5	0.600	32.0	0.101
25	20.5	0.600	7.0	0.947	28.5	0.670	25.0	0.530	9.0	0.840	1.0	0.970	5.0	0.960	5.0	0.950	11.0	0.750	1.0	1.000
26	20.5	0.600	2.0	0.996	10.0	0.900	11.0	0.700	7.0	0.850	17.5	0.870	3.0	0.980	1.0	1.000	1.5	1.000	2.0	0.990
27	20.5	0.600	1.0	1.000	30.0	0.650	16.0	0.610	3.0	0.930	17.0	0.870	1.0	1.000	4.0	0.970	4.0	0.950	3.0	0.980
28	1.0	1.000	23.0	0.876	26.0	0.700	14.0	0.640	13.5	0.830	24.5	0.850	13.0	0.720	17.5	0.485	11.0	0.750	11.0	0.564
29	20.5	0.600	5.0	0.957	19.0	0.770	6.5	0.750	9.0	0.840	3.0	0.930	2.0	0.990	2.0	0.990	4.0	0.950	4.0	0.978
30	0.5	0.600	22.0	0.878	1.0	1.000	12.0	0.690	26.0	0.760	17.5	0.870	10.0	0.750	21.0	0.420	17.5	0.700	12.0	0.653
31	20.5	0.600	3.0	0.987	5.0	0.940	8.5	0.720	6.0	0.860	8.0	0.900	4.0	0.975	3.0	0.980	4.0	0.950	5.0	0.960
32	20.5	0.600	19.0	0.890	19.0	0.770	22.0	0.550	28.5	0.720	13.0	0.880	18.0	0.620	13.0	0.570	17.5	0.700	14.0	0.551
33	20.5	0.600	26.5	0.873	6.0	0.980	10.0	0.710	19.5	0.800	9.5	0.890	21.0	0.590	12.0	0.573	17.5	0.700	15.0	0.550
34	20.5	0.600	16.0	0.921	19.0	0.770	3.5	0.810	13.5	0.830	21.0	0.860	15.0	0.670	8.0	0.600	11.0	0.750	17.0	0.548
35	20.5	0.600	21.0	0.883	2.0	0.980	2.0	0.820	13.5	0.830	13.0	0.880	12.0	0.730	9.0	0.595	17.5	0.700	10.0	0.555
36	20.5	0.600	31.0	0.813	22.0	0.750	1.0	1.000	24.0	0.770	24.5	0.850	23.0	0.570	10.0	0.594	26.5	0.600	21.0	0.544

^a RSS, radio science; IRIS, infrared radiation; ISS, imaging science; PPS, photopolarimetry; UVS, ultraviolet spectroscopy; CRS, cosmic ray particles; LECP, low-energy charged particles; MAG, magnetic fields; PLS, plasma particles; PRA, planetary radio astronomy.
SOURCE: Reprinted with permission from Dyer and Miles (1976).

difficult for them to consider the no-data trajectory pair with a significant, nonzero probability.

The very low utility function values assigned to the least preferred trajectory pairs could be explained as a conscious attempt to bias the results of the analysis. The science teams recognized that the maximum effect on the collective choice rules could be obtained by biasing these utility assignments downward. By spreading the utility function values for the candidate trajectory pairs over the entire range of [0.0, 1.0] rather than, say, over [0.8, 1.0], a science team would obviously have more influence on a multiplicative collective choice rule. In retrospect, it probably was not appropriate to request the science teams to evaluate the normalization lottery, thus in effect handicapping themselves.

17.3.2 THE COLLECTIVE CHOICE ANALYSIS

After the trajectory pair evaluation data had been received from all ten of the science teams, a collective choice analysis was performed at JPL. One of the principal issues of concern was the interteam normalization procedure. Because of this concern, two other normalization procedures were used to test the sensitivity of the alternative formulations to the utility function values assigned to the least preferred trajectory pairs. The second normalization procedure linearly transformed the utility function values of each science team as shown in Table 17.1 into the range [0.0, 1.0], where the value 0.0 was assigned to the least preferred trajectory pair. The third normalization procedure linearly transformed the utility function values of each science team for the 32 candidate trajectory pairs into a range assigned by the Project Scientist (who is responsible for coordinating the efforts of the scientists), based on his assessment of the appropriateness of the least preferred trajectory pair for each science investigation. The Project Scientist assigned the range [0.6, 1.0] to the science teams whose experiments emphasize data collected during encounters, and the range [0.8, 1.0] to the science teams with both cruise and encounter objectives.

The first transformation eliminated the possible errors introduced by the difficult normalization lottery but made the case for an unequal specification of the λ^i weights more compelling if the results were to be used in an additive collective choice model. There was no longer any reason to believe that the magnitude of the preference difference for each team was adequately reflected in the utility function values. In the second transformation, the Project Scientist was actually imposing a nonlinear f^i transformation of the u^i functions, since the utility function value of the no-data trajectory was left at 0.0 for each team. This manipulation of the u^i values is justified by the formulation as a single-decision-maker problem with multiple attributes (17.6). It should be noted that the Project Manager delegated the task of manipulating the u^i values to the Project Scientist, who was more familiar with the technical aspects of each experiment.

Another issue was the choice of the weighting factor λ^i for each science team in

the additive collective choice rules. Two sets of weighting factors were used: equal weights of $\lambda^i = 1.0$ for all science teams; and $\lambda^i = 2.0$ for the encounter-oriented science teams and $\lambda^i = 1.0$ for the other science teams. Both sets were readily accepted by the SSG as representative weighting factors for a sensitivity analysis.

The results of the analysis with the various collective choice rules are presented in Table 17.2 for the ten trajectory pairs ranked highest by the rank sum collective choice rule. The collective choice rules were scaled to yield values in the range [0.0, 1.0] for ease of comparison. All of the collective choice rules would assign a value of 1.0 to a trajectory pair that was evaluated as the most preferred trajectory pair by every science team.

The trajectory pair rankings by the rank sum rule are shown in the first data column of Table 17.2, with the values in the second column being the mean ranks of the science teams linearly transformed into the range [1/32, 1.0], with 1.0 most preferred. The next six collective choice rules are based on the additive form – (17.2) or (17.6) – with the two weighting factor sets times the three normalization procedures accounting for these six data columns. Finally, the last two collective choice rules are based on the multiplicative rule (17.1), with the no-data trajectory pair taken as the status quo alternative. The two multiplicative rules differ in that the utility function values for one rule are linearly scaled upward from $u^i(r_i^j) = p_i^j$ as assigned by the science teams, and for the second rule from $u^i(r_i^j) = 0.6$ or 0.8 as assigned by the Project Scientist.

The majority decision rule was not included in the JPL analysis because of concern that cyclic results might be obtained. The application of the majority decision rule to the ten trajectory pairs ranked highest by the rank sum rule preserved acyclicity but did result in two ties, thus forming the following ordering: $(26 \succ \{29, 27, 31\} \succ 25 \succ 5 \succ 8 \succ 35 \succ 17 \succ 10)$ with $29 \sim 27$, $27 \sim 31$, and $29 \succ 31$. The trajectory pairs ranked in the top four by the majority decision rule were ranked in the top four by all the collective choice rules of Table 17.2.

The data in Table 17.2 do indicate a substantial agreement among the nine collective choice rules presented there. This is partially fortuitous; partially a result of the science selection process of NASA, which emphasized compatibility as a major criterion; and also partially a result of the statistical properties of these rules. All the collective choice rules could be expected to be highly correlated on a statistical basis. Sums and products of random variables are highly correlated, even if the random variables are independent and uniformly distributed over their domain.

The results in Table 17.2 can be used to illustrate some of the limitations of these collective choice rules in practical applications. For example, trajectory pair 29 has a higher rank sum value than trajectory pair 26. However, if trajectory pair 10 had been omitted from the analysis, this relationship would have been reversed, demonstrating the dependence of this rule on irrelevant alternatives. (This can be calculated from the data in Table 17.3, in the following section.) Similarly, trajectory pair 26 is ranked first by the additive collective choice rule when the interteam normalization strategy based on the no-data trajectory pair and equal

TABLE 17.2 Collective Choice Rankings and Values

Trajectory Pair		Additive																
		λ^i Weighting = 1.0				λ^i Weighting = 1.0 or 2.0				Nash								
		$u^i(t^i_j) = p^i_j$		$u^i(t^i_j) = 0.0$		$u^i(t^i_j) = 0.6$ or 0.8		$u^i(t^i_j) = p^i_j$		$u^i(t^i_j) = 0.0$		$u^i(t^i_j) = 0.6$ or 0.8		$u^i(t^i_j) = p^i_j$ or 0.8				
Rank	Sum	Rank	Value	Rank	Value	Rank	Value	Rank	Value	Rank	Value	Rank	Value	Rank	Value			
31	1	0.822	2	0.887	1	0.724	1	0.901	1	0.871	1	0.691	1	0.884	1.5	0.877	1	0.892
29	2	0.797	3	0.875	3	0.692	3	0.884	3	0.852	3	0.638	3	0.860	3	0.865	3	0.874
26	3	0.795	1	0.889	2	0.710	2	0.896	2	0.870	2	0.676	2	0.878	1.5	0.877	2	0.886
27	4	0.719	4	0.856	4	0.641	4	0.871	4	0.833	4	0.596	4	0.848	4	0.839	4	0.856
5	5	0.683	6	0.791	6	0.555	8	0.841	6.5	0.765	8	0.502	12	0.813	6	0.776	11	0.829
25	6	0.678	5	0.822	5	0.597	5	0.851	5	0.800	5	0.535	9	0.822	5	0.804	7	0.836
35	7	0.655	7	0.757	8	0.511	6.5	0.846	6.5	0.765	7	0.517	5.5	0.833	8	0.745	6	0.839
17	8	0.622	10	0.738	11	0.475	10.5	0.836	10	0.746	10	0.487	8	0.823	10.5	0.725	9.5	0.830
8	9	0.611	8	0.755	9	0.488	10.5	0.836	8	0.756	11	0.486	10	0.820	7	0.746	9.5	0.830
10	10	0.605	12	0.728	7	0.514	6.5	0.846	11	0.744	6	0.519	5.5	0.833	14	0.706	5	0.843

λ^i weights are used, but it falls to second when the normalization strategy is changed, or when the unequal (1.0 or 2.0) weighting factors are used. Finally, rescaling the utility function values, so that $u^i(t_i^i) = 0.6$ or 0.8 , is equivalent to changing the status quo point in the multiplicative rule. The sensitivity of the resulting solution to this change is evidenced by trajectory pair 10, which is ranked only fourteenth by this collective choice rule when $u^i(t_i^i) = p_i$ but is ranked fifth when $u^i(t_i^i) = 0.6$ or 0.8 .

17.3.3 THE SCIENCE STEERING GROUP MEETING

Following the science team evaluation and the JPL analysis of the candidate trajectory pairs, the SSG addressed the selection of the preferred trajectory pair at the SSG meeting of October 22–23, 1973. Initial discussions clarified the trajectory requirements of the individual science teams. However, no rationale emerged for trading off incompatible requirements, and no means was found for moving from the general trajectory requirements to the selection of a specific trajectory pair. At this point, the SSG requested that JPL present the collective choice analysis, which is summarized in Tables 17.2 and 17.3. Table 17.3 shows the science team ordinal rankings for the ten trajectory pairs ranked highest by the rank sum collective choice rule.

Two observations that can be made from Tables 17.2 and 17.3 are of primary importance. First, trajectory pairs 31, 29, and 26 are ranked as the top three by all the collective choice rules. In the ensuing discussion, the majority of the SSG expressed a preference for one of these three trajectory pairs. Second, the Radio Science Team (RSS) considered any trajectory pair ranked high by the collective choice rules to be undesirable.

TABLE 17.3 Science Team Ordinal Rankings for Preferred Trajectory Pairs

Trajectory Pairs	Collective Choice Ranking		Science Team Ordinal Rankings									
	Rank Sum	Additive $u^i(t_i^i) = p_i; \lambda^i = 1.0$	RSS	IRIS	ISS	PPS	UVS	CRS	LECP	MAG	PLS	PRA
31	1	2	20.5	3.0	5.0	8.5	6.0	8.0	4.0	3.0	4.0	5.0
29	2	3	20.5	5.0	19.0	6.5	9.0	3.0	2.0	2.0	4.0	4.0
26	3	1	20.5	2.0	10.0	11.0	7.0	17.5	3.0	1.0	1.5	2.0
27	4	4	20.5	1.0	30.0	16.0	3.0	17.5	1.0	4.0	4.0	3.0
5	5	6	20.5	9.0	28.5	17.0	4.0	13.0	6.0	6.0	1.5	6.0
25	6	5	20.5	7.0	28.5	25.0	9.0	1.0	5.0	5.0	11.0	1.0
35	7	7	20.5	21.0	2.0	2.0	13.5	13.0	12.0	9.0	17.5	10.0
17	8	10	20.5	4.0	13.5	6.5	13.5	24.5	9.0	14.0	17.5	8.0
8	9	8	20.5	20.0	10.0	5.0	13.5	21.0	11.0	7.0	17.5	9.0
10	10	12	3.0	11.0	24.0	8.5	19.5	2.0	20.0	24.0	17.5	7.0

The team leader of the Imaging Science Investigation (ISS) expressed a dislike for trajectory pair 29, to which the team had assigned an ordinal ranking of 19 and a utility function value of 0.770, but he indicated that either trajectory pair 31 or 26 would be acceptable (utility function values of 0.940 and 0.900). The team leader of the Cosmic Ray Investigation (CRS) stated that they could accept trajectory pair 26, which, even though ordinarily ranked at 17.5, was given a utility function value of 0.870 (compared to 0.900 for trajectory pair 31). The team leader of the Radio Science Investigation expressed a preference for trajectory pair 26 over trajectory pair 31. (One member of the SSG immediately observed that the Radio Science Team should have expressed this preference in their ordinal rankings and utility function values.) The other team leaders expressed their satisfaction with either trajectory pair 31 or 26.

On the basis of this discussion, trajectory pair 26 was tentatively selected as the science-preferred trajectory pair. The JPL trajectory analysts worked that night to improve the geometry of trajectory pair 26 for the Radio Science Investigation team without degrading the features of the trajectories that appealed to the other science teams. This analysis was presented to the SSG the following morning and met with approval. The modified version of trajectory pair 26 was approved by the Project Manager and was documented as the MJS77 "Standard Trajectories" (Beerer *et al.*, 1974). The two trajectories were labeled JSI and JSG, where JS stands for Jupiter/Saturn, and I and G stand for Jupiter's satellites Io and Ganymede, which are encountered on the corresponding trajectories.

17.4 CONCLUSIONS

The trajectory selection process was successful in that it led to a decision generally acceptable to all of the science teams. This success was due to a number of factors. By means of the mission constraints imposed on the trajectory design, it was possible to separate programmatic issues from the science issues. Thus the science teams could be asked to evaluate the trajectory pairs solely on the basis of their scientific merits. Another important factor was that compatible alternatives actually existed – this is partially fortuitous but more strongly a result of the detailed project planning and coordinated science investigation selection process. The collective choice rules were in general agreement, reflecting this compatibility.

The science teams willingly participated in the trajectory selection process because they recognized that it was necessary that they understand the trajectory alternatives and develop their science investigation requirements, and they recognized that if a consensus could be reached among the science teams, the Project Manager would accept their recommendation as the Project standard trajectory pair. Also, the science teams had participated in the generation of the trajectory pairs, and the set of candidate trajectory pairs contained at least one trajectory pair that was considered very good by each science team.

Clearly, the ordinal rankings of the trajectory pairs by the science teams were essential to the selection process. These ordinal rankings and the rank sum collective choice rule probably would have been sufficient to identify either trajectory pair 26 or 31 as the science-preferred trajectory pair. Nevertheless, we conclude that the cardinal utility evaluation by the science teams and the use of nine collective choice rules based on three different viewpoints of the problem were an important part of the selection process. The cardinal utility evaluation aided the selection among trajectory pairs 26, 29, and 31; it tested the analysis for sensitivity to strength of preference not revealed by the ordinal rankings; and it permitted the use of a wider range of alternative assumptions in the analysis. The use of alternative formulations from three different viewpoints ensured that the solution was not particularly sensitive to some specialized assumption associated with any one of them.

Could the selected trajectory pair have been identified without the formalities of the decision analysis? The science teams generally believed that the same trajectory pair would have been selected without the development of the ordinal rankings and the utility function values [see Dyer and Miles (1976) for an extended discussion]. While there is no definitive answer to this question, there are two indications that it would not have been. First, the SSG was given several opportunities to identify a science-preferred trajectory pair, and it did not do so. Second, the Project and the science teams earlier had been working with a trajectory pair developed during the preceding year. It had been assumed that this earlier trajectory pair was quite satisfactory, and it could have been expected to rank high among the other alternatives. This earlier trajectory pair was included on the candidate list as trajectory pair 20. It was most surprising to find that trajectory pair 20 was ranked twenty-eighth by the rank sum collective choice rule.

In summary, the methodology presented in this paper did provide a suitable framework for each science team to assess its preferences and a means of communicating these preferences to the other science teams. The science teams were then able to arrive at a consensus in an effective manner and to recommend to the Project a science-preferred trajectory pair that was subsequently implemented as the Project standard trajectory pair.

REFERENCES

- Beerer, J.G., P.A. Penzo, and R.A. Wallace. 1974. Mariner Jupiter/Saturn 1977 standard trajectories. Project Document 618-113. Jet Propulsion Laboratory, Pasadena, California.
- Bonnardeaux, J.A., J.P. Dolait, and J.S. Dyer. 1976. The use of the Nash bargaining model in trajectory selection. *Management Science*, Vol. 22, pp. 766-777.
- Debreu, G. 1960. Topological methods in cardinal utility theory. In *Mathematical Methods in the Social Sciences, 1959* (K.J. Arrow, S. Karlin, and P. Suppes, eds.). Stanford University Press, Stanford, California.
- Dyer, J.S., and R.F. Miles, Jr. 1976. An actual application of collective choice theory to the

- selection of trajectories for the Mariner Jupiter/Saturn 1977 Project. *Operations Research*, Vol. 24, pp. 220–244.
- Farquhar, P.H. 1975. A fractional hypercube decomposition theorem for multiattribute utility functions. *Operations Research*, Vol. 23, pp. 941–967.
- Fishburn, P.C. 1970. *Utility Theory for Decision Making*. John Wiley, New York.
- Fishburn, P.C. 1971. A comparative analysis of group decision methods. *Behavioral Science*, Vol. 16, pp. 538–544.
- Fishburn, P.C. 1973. *The Theory of Social Choice*. Princeton University Press, Princeton, New Jersey.
- Fishburn, P.C. 1974. Von Neumann–Morgenstern utility functions on two attributes. *Operations Research*, Vol. 22, pp. 35–45.
- Harsanyi, J.C. 1955. Cardinal welfare, individualistic ethics, and interpersonal comparisons of utility. *Journal of Political Economy*, Vol. 63, pp. 309–321.
- Harsanyi, J.C. 1956. Approaches to the bargaining problem before and after the theory of games: a critical discussion of Zeuthen's, Hicks', and Nash's theories. *Econometrica*, Vol. 24, pp. 144–157.
- Harsanyi, J.C. 1959. A bargaining model for the cooperative n -person game. In *Contributions to the Theory of Games* (H.W. Kuhn and A. Tucker, eds.). Vol. 4. Princeton University Press, Princeton, New Jersey.
- Keeney, R.L. 1974. Multiplicative utility functions. *Operations Research*, Vol. 22, pp. 22–34.
- Keeney, R.L. 1976. A group preference axiomization with cardinal utility. *Management Science*, Vol. 23, pp. 140–145.
- Keeney, R.L., and C.W. Kirkwood. 1976. Group decision making using cardinal social welfare functions. *Management Science*, Vol. 22, pp. 430–437.
- Miles, R.F., Jr., and J.S. Dyer. 1977. A critique and application of collective choice theory: trajectory selection for the Mariner Jupiter/Saturn 1977 project. Working Paper 6001-1. Jet Propulsion Laboratory, Pasadena, California.
- Nash, J.F., Jr. 1950. The bargaining problem. *Econometrica*, Vol. 18, pp. 155–162.
- Rapoport, A. 1975. Interpersonal comparisons of utility. In *Multiple Criteria Decision Making* (M. Zeleny, ed.). Springer-Verlag, New York.
- Schurmeier, H.M. 1974. The Mariner Jupiter/Saturn 1977 Mission. In *Eleventh Space Congress Proceedings*. Vol. II. Canaveral Council of Technical Societies, Cocoa Beach, Florida, pp. 4-28–4-41.
- Sen, A.K. 1970. *Collective Choice and Social Welfare*. Holden-Day, San Francisco.
- Shapley, L.S., and M. Shubik. 1971. Game Theory in Economics – Chapter 1: Introduction. The Use of Models. R-904/1-NSF. The Rand Corporation, Santa Monica, California.
- Shapley, L.S., and M. Shubik. 1974. Game Theory in Economics – Chapter 4: Preferences and Utility. R-904/4-NSF. The Rand Corporation, Santa Monica, California.
- Suppes, P., and M. Winet. 1955. An axiomization of utility based on the notion of utility differences. *Management Science*, Vol. 1, pp. 259–270.
- von Neumann, J., and O. Morgenstern. 1947. *Theory of Games and Economic Behavior*. Princeton University Press, Princeton, New Jersey.

DISCUSSION

ZIONTS: You started with 105 single trajectories. How did you get from this to the 32 trajectory pairs? Are there any dominance considerations in the ratings?

DYER: Since you can't launch two spacecraft within 2 weeks from the same launch pad, not all combinations are possible. This certainly helped the JPL representatives, who picked 40 trajectory pairs and presented them to the scientists. The scientists threw out something like 10 or 12 of those 40 and added 6 more.

The process was repeated until every science team felt that several trajectory pairs in the set were desirable.

ZIONTS: What about the 32? Were there no cases of dominance?

DYER: Yes, there were. However, we analysts did not try to go through and say we were excluding pairs at all. We were sensitive to the notion that the scientists should do that. Even if there was dominance in terms of the information that they had given us, we did not want to throw anything out.

TVERSKY: It seems to me that the analysis was quite effective in helping this community to exploit consensus or to reach a satisfactory decision. I'd say that it may not have been maximally effective from the standpoint of changing their way of thinking about the problem. This, I think, is probably a consequence of the fact that you accepted the scientific teams' basic attributes rather than trying to restructure the problem in terms of the real attributes involved. It is very unlikely that, if you were to analyze the dimensionality of the structure of the information to be obtained from such a mission, it would correspond exactly with the number of teams involved. My comment is not meant, of course, as a criticism of the analysis. It just seems that most of the effort went into devising and ranking alternative schemes rather than into thinking about the value dimensions that were involved.

DYER: Your point is a good one. I am certainly not convinced that the selected trajectory pair was best in the sense of science value, whatever that means. I think some sort of a multiattribute analysis would have been more appropriate. It was our opinion that we could not have done such an analysis. Our judgment was that the teams did not like talking about the objectives of their experiments. When we tried it, they would make comments like, "We have not been up there before, and we have to get there before we know what we want to do."

TVERSKY: My second question has to do with the use of lotteries in this case. I think that it might well be argued that you really do not want to bring in lotteries, particularly if you do not deal with the underlying value dimension but with the team. Perhaps some kind of trade-off technique would be more appropriate than introducing uncertainty as was done in these assessments. It seems to me that the key criterion is whether there is a genuine uncertainty in the environment.

DYER: In practice, teams used different procedures. Some teams assigned numbers directly, and one team even evolved their own so-called value functions, which they used to generate their rankings.

MEYER: First of all, I'd like to emphasize some points that Dr. Tversky has already made. If you do want to ask lotteries over the range from the worst to the best point, then you should reflect the uncertainty of the real problem. If there is indeed a substantial chance of the mission somehow going astray and no information coming to the science teams, then that is a reasonable lower position for gambles stakes. If there is no substantial chance or if the teams are not willing to admit psychologically that there is a substantial chance, then that is not a proper range for gambles. The range of the gamble has to correspond with the range of outcomes that they consider likely.

DYER: I agree with that. The Atlantic Ocean Special is a real possibility for this mission; it has occurred before. My more serious concern was that what was reflected in the responses to the gambles had very little to do with the notion of the value of the trajectory pair. I think they were very much influenced by personal desires to be involved in the space flight. I think this is particularly exhibited with those extremely risk-averse responses. We were getting away from what we really wanted, which was an evaluation of trajectory pairs based on how good it was for the experiment.

MEYER: Your problem might have been quite different if some of the trajectory pairs had been much more risky, in the sense of chances of successfully completing the mission, than others. If that had been the case, then the Atlantic Ocean alternative would have been a real alternative and you would probably not have seen all these effects.

I am also disturbed about the arbitrariness of scaling that is implied by choosing the zero point in the way you did. Did you consider asking the different teams to identify an equal-value alternative that might be defined as follows? You bring all the teams together with the mission director and try to reach a consensus about one set of outcomes in which they feel they are all being treated fairly. To do this, each of the teams could pick one alternative that they consider to be as good for them as another alternative for the other teams. If you could have done that – I am not saying you could have – then you could presumably infer from that what the scaling on the teams' utility functions should be.

DYER: I don't think that could be done. It's a nice idea, but the scientists on each team felt that they were the only people who really understood their experiment. The teams would have strongly objected to such an approach.

RAIFFA: That's a nice scheme to do, and I have done arbitration schemes like that. But once the people know that procedure, there is a great deal of motivation to be dishonest about their preferences. I have done experiments in the laboratory where we go through bargaining processes. If you tell the subjects what the process is, they will sometimes figure out the optimal way to exaggerate their beliefs, in order to win their point of view. I don't know of any procedures in these group problems that can prove that the optimal procedure is to tell the truth, but if you give a very, very complicated rule and then ask people for their beliefs, they cannot easily figure out how to subvert the analysis. In fact, most of the subjects that I have been involved with simply decide that the easiest thing to do is to tell the truth.

DYER: I think we saw examples of both types of behavior. We did see some gaming, whereas some assessments were done very honestly, in my opinion. In one case, the RSS team assigned nonzero utilities to only six trajectory pairs. Since none of those six trajectory pairs was well received by the other nine teams, these six pairs were in effect left out of the analysis. Hence, RSS had essentially no impact on the analysis.

EDWARDS: Since there are, in fact, two distinct portions of this mission, the Jupiter passage and the Saturn passage, it might have been that different groups had very different models of these two portions of the mission. Some of the scaling

problems might have been easier if you had scaled the merits of those two portions of the mission separately. Then by taking a simple additive rule or something of the sort, you might have been able to avoid some of the zero-point problems.

DYER: I agree with you, and I think it would have been worthwhile to do that. After talking to the representatives of the scientists, I was convinced that there was probably no simple rule for combining preferences for the trajectories. Saturn and Jupiter are both unexplored bodies and are similar in terms of physical properties, so the data collected about one affects the feelings of the scientists about data collected from the other. What the scientists did seem to think would be reasonable, and perhaps we could have done it, was to consider the planets together as one unit and their satellites together as another.

LUCE: Along the same lines, what about assigning utilities to each of the two single trajectories and then adding?

DYER: Again, I don't think there would be any simple rule for combining the utilities of the individual trajectories, because what one trajectory achieves very much affects one's feelings about the other. If the first trajectory collects data A , the scientific value of collecting those same data with the second trajectory is greatly diminished.

EDWARDS: When I have worried about classes of problems of this general flavor, I have always found myself starting off with the goal of picking a good solution and ending up by picking a lot of bad ones. And I have come to wonder whether maybe that does not represent a good technique. You certainly did, in fact, end up by picking a lot of bad ones to eliminate by techniques of varying degrees of formality. What might have happened and how might your respondents have reacted if you had defined the problem along those lines from the beginning?

DYER: I don't know, but I think the scaling we used is consistent with the way they like to think about the problem.

EDWARDS: There is another possible advantage of that approach – it would not cause the same kind of problems that gaming the system causes here. Once you got rid of all the poor alternatives, you could allow any one of a wide variety of bargaining systems to be used among the participants and still feel reasonably confident that what was going to come out would be acceptable.

KEENEY: After you showed the analysis to the teams, did they have an opportunity to design a few new trajectory pairs that seemed better than any of the 32 originally generated? I think this would be quite important and interesting.

DYER: On the basis of our analysis, trajectory pair 26 was tentatively selected by the scientists as the preferred pair. The JPL trajectory analysts worked all night to generate 11 new trajectory pairs that were very similar to pair 26 but had better features for the RSS team near Saturn. These were presented to the scientists the next morning, and, after 3 hours of discussion, one of these was identified as preferred. The JPL analysts used the comments at this meeting to refine this pair even further before it was finally adopted.

18 A Decision Analysis of Objectives for a Forest Pest Problem

David E. Bell

This paper describes an attempt to determine and quantify preferences for a forest region in New Brunswick, Canada. The forest is subject to outbreaks of the spruce budworm, a pest that does great damage to the trees and thus to the logging industry, which is a major part of the economy of the province. DDT has been sprayed so extensively for the past 20 years that if the spraying were to stop, an extensive outbreak would be expected. The Ecological and Environmental Systems Project at the International Institute for Applied Systems Analysis (IIASA) was using a detailed simulation model of the forest to examine possible strategies for handling the pest (see Holling *et al.*, 1974), and the IIASA methodology project was contributing to the study by creating a dynamic programming optimization algorithm (Winkler, 1975). The study outlined here started when I attended a joint meeting of these two projects together with some experts from the Canadian Forestry Commission. The purpose of the meeting was to establish an objective function for the optimization model by fitting values of c_i to the linear formula

$$c_1(\text{egg density}) + c_2(\text{stress})^1 + c_3(\text{proportion of old trees}) \\ + c_4(\text{proportion of new trees}). \quad (18.1)$$

I am grateful for the contributions of many of my colleagues to the work described in this paper, in particular to Bill Clark, with whom I spent many hours, not only on matters of specific assessment but also in discussing ways to make decision analysis more applicable to ecological problems and in philosophizing about the "time problem," the question of how to assess preferences over time. Professor C.S. Holling, the leader of IIASA's ecology project, spent days clarifying questions on the model and making seemingly endless lists of possible indicators for our, then still unnamed, decision maker to study. I am grateful to George Dantzig for his encouragement and meticulous reading of an earlier draft of this paper and to Ralph Keeney both for introducing me to the subject of decision analysis and for the many stimulating discussions that we have had on this project and other topics since.

¹Stress is a measure of the health of the trees judged by the amount of defoliation in current and previous years caused by the budworm.

This disturbed me for two reasons. First, they did not appear to have a very accurate way of arriving at the parameters. Second, they seemed concerned only with monetary gains and losses to the logging industry — I had always supposed that IIASA's ecology project was also concerned with protection of wildlife and scenery. I began this study with two aims:

- To derive the parameters c_i for the optimization model by different means as a comparison
- To discover the true preferences of the members of the ecology project regarding trade-offs between profits, wildlife, and the environment

This paper describes my progress over the next 18 months toward achieving these aims. In performing the analysis, inevitably many mistakes were made, and if I were to analyze a similar study now, I would do a great many things differently. However, I have chosen to describe here what actually happened rather than to serve up a neat exposition of decision analysis at its best. It should be borne in mind that this study was not planned in detail; rather, it developed on a week-by-week basis and was subject to constant interruptions, including two 6-month separations of analyst and decision maker.

The benefits of this sort of presentation, I hope, are that, on the one hand, a number of theoretical issues are raised to which some attention should be paid and, on the other, potential analysts who may feel daunted by the imposing literature on decision analysis may be encouraged to give it a try themselves.

In order to keep the paper to a reasonable length, many of the decision analysis concepts used — such as value function, utility function, and various independence assumptions — are described rather cursorily, and the reader who is not well acquainted with their definitions should consult Raiffa (1969) or Keeney and Raiffa (1976).

18.1 PRELIMINARY ANALYSIS

I began by asking five of the conference participants (three from IIASA and two from the Canadian Forestry Commission) to rank a list of states of the forest, exhibited in Table 18.1, by preference; after they had done this, I asked them to give a value of 0 to 100 to each state, indicating its "worth." They were to rank the list by taking any pair of forest states (summarized by the five data points) and decide which state they would prefer the forest to be in, assuming that from then on man was left to manage it in any way he could. The value they gave to each state could be derived by any reasoning they wished; the only requirement was that the ordering of preferences and of values be the same.

I then used a statistical software package to obtain regression coefficients

TABLE 18.1 Forest States

Forest State	Proportion of Young Trees	Proportion of Medium-Age Trees	Proportion of Old Trees	Stress	Egg Density
1	0.10	0.30	0.60	0	0.3
2	0.15	0.35	0.50	0	0.6
3	0.10	0.40	0.50	0	0.5
4	0.20	0.50	0.30	20	1.0
5	0.10	0.30	0.60	10	0.1
6	0.10	0.30	0.60	40	0.1
7	0.10	0.40	0.50	0	0.5
8	0.15	0.35	0.50	0	0.6
9	0.50	0.10	0.40	0	2.0
10	0.20	0.50	0.30	20	1.0
11	0.20	0.20	0.60	20	10
12	0.10	0.30	0.60	50	10
13	0.20	0.30	0.50	20	10
14	0.20	0.30	0.50	50	10
15	0.20	0.40	0.40	20	10
16	0.20	0.40	0.40	50	10
17	0.30	0.40	0.30	20	10
18	0.20	0.50	0.30	50	10
19	0.30	0.40	0.30	30	80
20	0.30	0.30	0.40	0	50
21	0.20	0.20	0.60	0	150
22	0.10	0.60	0.30	10	200
23	0.20	0.20	0.60	0	500
24	0.10	0.30	0.60	40	500
25	0.30	0.30	0.40	40	500
26	0.30	0.40	0.30	0	500
27	0.30	0.40	0.30	40	500

(see, for example, Draper and Smith, 1966) for the linear formula (18.1) by using egg density, stress, and proportion of old and young trees as independent variables and the value as the dependent variable, deriving one formula for each of the five participants. The formulas I derived from the rankings of the two Forestry Commission members were very close to the parameters c_i actually obtained at the meeting (despite my misgivings), but those of the three ecology project members were quite different from the other two and from each other.

After discussion with the ecologists on the reasons for these differences, the feeling emerged that the states in Table 18.1 were meaningless because the whole forest could not be composed uniformly (the forest covers about 15,000 square miles). Indeed, if it were, all 27 states would be equally terrible. I asked them whether they could describe a new state vector that would be meaningful.

18.1.1 DEFINING A MEANINGFUL STATE DESCRIPTION

Professor Holling then devised a list of seven typical endemic conditions of a sub-forest together with their appropriate vector state classification. A new list was then drawn up (Table 18.2) in which the states of the forest were described by seven parameters (summing to 1), giving the proportion of the total forest in each condition category.

All four members of the ecology group were then asked for their preference rankings of these 20 states (the Forestry Commission experts had returned to Canada). In addition, I calculated the ranking implied by the objective function from the stand model used in the dynamic programming formulation. The correlation between each pair of the five rankings was calculated. This ranged from 0.3 to 0.8 for pairs of ecologists and was negative for all ecologist/objective-function pairs. The marked difference between the ecologists and the "forest industry" experts partly reflected the fact that the experts were thinking only in terms of the immediate future, whereas the members of the ecology group were thinking of the long-term implications of the various states.

However, there were still differences in preferences within the ecology group. The preferences of Holling and Clark were essentially the same, though they arrived at their orderings in completely different ways. Holling first created seven functions $v_1(p_1), v_2(p_2), \dots, v_7(p_7)$, which gave his subjective "value" to having a proportion p_i of the forest in condition i . [Note that he has thus made some assumption of independence between the parameters; for a discussion of this topic see Keeney and Raiffa (1976, section 3.5).] Hence, he assigned a value of

$$v_1(0.0023) + v_2(0.0061) + \dots + v_7(0)$$

to forest state 2 in Table 18.2 and then used this value to obtain his ranking. Clark fixed his sights on having about 5–10% of the forest in condition 4 (triggered outbreak) and on keeping the predictability of the forest high (by having the proportions in conditions 3 and 7 low). He was aiming for a manageable forest.

A general discussion of what was desirable ensued. Predictability seemed to be one valued characteristic. (I gained a new perspective on the problem when I asked Holling why he ranked forest mix 20 in Table 18.2 last. "Worst thing that could possibly happen," he said.) Another such characteristic was a desire to take the observed historical budworm outbreaks over time (a cycle of the forest moving through conditions 1–6 sequentially) into the same pattern over space: that is, to have the same proportion of the forest in each condition at any given time – "controlled outbreaks."

It was decided that the seven statistics used were not sufficient to describe the state of the forest, and Holling set to work on a more comprehensive list of indicators. The aim was to devise a system with which we could enable a decision maker ("magically") to place the forest in condition A or condition B , where A and B are described by a set of summary statistics. Which statistics would the decision maker like to see to enable him to make a decision? If he were a logger, he would

TABLE 18.2 Types of Forest Mix

Forest Mix No.	Proportion of Land In Condition						
	1 (Postoutbreak Endemic)	2 (Mid-endemic)	3 (Potential Outbreak)	4 (Triggered Outbreak)	5 (Mid-outbreak)	6 (Disaster)	7 (Budworm Extinct)
1	0	0	1.0	0	0	0	0
2	0.0023	0.0061	0.975	0.0016	0.0083	0.0017	0
3	0.0047	0.0122	0.96	0.0033	0.0165	0.0033	0
4	0.0122	0.0122	0.95	0.0033	0.0165	0.0033	0.0025
5	0.04	0.04	0.85	0.01	0.05	0.01	0
6	0.045	0.05	0.80	0.02	0.06	0.02	0.005
7	0.08	0.08	0.70	0.02	0.10	0.02	0
8	0.026	0.226	0.70	0.007	0.033	0.007	0.001
9	0.06	0.04	0.66	0.08	0.10	0.02	0.02
10	0.08	0.04	0.66	0.08	0.10	0.02	0
11	0.03	0.27	0.53	0.06	0.15	0.03	0
12	0.12	0.10	0.53	0.06	0.15	0.03	0
13	0.0244	0.48	0.48	0.0033	0.0165	0.0033	0.0025
14	0.04	0.44	0.45	0.01	0.05	0.01	0
15	0.045	0.42	0.43	0.02	0.06	0.02	0.005
16	0.052	0.41	0.41	0.041	0.058	0.012	0.001
17	0.16	0.16	0.4	0.04	0.2	0.04	0
18	0.35	0.08	0.35	0.08	0.10	0.02	0
19	0.08	0.35	0.35	0.08	0.10	0.02	0
20	0	0	0	0	0	0	1

want to know, among other things, the amount of wood in good condition for logging and the forest's potential for the next few years, as indicated by the level of budworm.

For any given decision maker we would like to build up a set of statistics (indicators) that would tell him all (or virtually all) he wants to know in order to choose between *A* and *B*.

To put this into practice, a member of the group, Bill Clark, who was well acquainted with the problems of the area, was appointed a decision maker. After Holling had drawn up a long list of possible indicators, we three had a meeting to discuss this list with Clark. Which ones was he interested in?

We then ran into a problem. When a decision maker evaluates the present state of the forest, he has to look to the future. He has to predict how the forest will behave, keeping in mind the present number of budworms, for example. Hence, when he evaluates the forest condition, he includes in his evaluation his judgment of how the forest will develop in the future, and the way in which the forest develops depends on the method of treatment — that is, on the policies on logging, spraying, and the like.

Recall that we are looking for an objective function that we can optimize to find a best policy for treating the forest. However, if the decision maker had known of this “best policy,” he might have evaluated the forests differently, which changes the best policy. As an example, suppose that a simple device is discovered that removes all possibility of a budworm outbreak. The forest preferences of the decision maker will be altered. Although the result of the optimization procedure may not be as good as this “device,” it nevertheless may change his preferences. What is needed is a set of statistics such that preferences for their values are independent of the policy being used.

This was achieved by letting the decision maker view a stream of statistics about the conditions of the forest over a sufficiently long time horizon. Hence the decision maker need not predict anything. He is to evaluate the stream of statistics as one single finished product and need not worry about how likely they are or wonder what policy achieved them. The internal policies of the simulator must then be adjusted to maximize the value assigned by the decision maker.

Note that the type of statistics required has now changed. It is not necessary to know the density of budworm at any given time; that was needed only to get an idea about the future state of the trees. Since we can also see the quantity of lumber obtained for the next 100 years and the amount spent on spraying, it is irrelevant to know how much budworm is present. (Indeed, it is probably irrelevant to know how much was spent on spraying — a simple net profit or loss may be sufficient.)

18.1.2 FINDING THE ATTRIBUTES RELEVANT TO OUR DECISION MAKER

Clark went through Holling's list of indicators deleting, adding, and modifying. Some were discarded for being too minor, that is, not likely to influence his

decisions; others, because their implications were too difficult to understand (particularly standard deviations of data over space). The following list of statistics for each year that Clark felt would affect his decisions was the result.

Financial

X_1 = Profit of logging industry

X_2 = Cost of logging

X_3 = Cost of spraying

Logging Potential of Forest

X_4 = Amount of harvestable wood

X_5 = Percent of X_4 actually harvested in the given year

Forest Composition

X_6 = Diversity, a measure of the mixture of differing classes, ages, types of trees for recreational purposes (the greater the diversity the better)

X_7 = Percentage of old trees

Observable Damage

X_8 = Percentage of defoliated trees

X_9 = Percentage of dead trees

X_{10} = Percentage of logged areas (no trees or stumps)

Social

X_{11} = Unemployment (measured by taking a certain logging level as full mill capacity)

Insecticide

X_{12} = Average dosage per sprayed plot

In addition to the list above, a variance for these statistics taken over 265 sub-regions of New Brunswick was also included in some cases.

Ignoring the variances for a moment, this still leaves $12 \times T$ statistics for a history of T periods. Indeed, eight of these statistics were intended for each site, which would have given $(4 + 265 \times 8)T$ statistics.

Two 50-year histories were generated by the simulation model with an initial set of internal policies, and these statistics calculated. Clark studied these listings and, following his earlier procedure for ordering the listing on Table 18.2, picked a few key statistics that he wanted to maintain at a certain level and then checked to see that the others were not seriously out of line. The idea at this stage was to give him a sequence of about 12 such 50-year listings of statistics and ask him to order them. Then he would be given the complete simulation outputs and asked to rank those; then the two lists would be compared. In this way the list of statistics would be

modified, and he would learn better what their implications were, so that eventually he would be able to arrive at the same orderings for the complete listings and the reduced set of statistic listings. Owing to the mechanical difficulty of keeping IIASA's computer in operation and to lack of time, however, this was not done. Nevertheless, for the sake of outlining the full procedure, let us assume that it was done.

We then set about reducing the remaining list of statistics (X_1 to X_{12}) to a manageable size of at most five or six per day. I successfully argued that since the potentially harvestable wood, potentially harvestable wood harvested, cost of spraying, and insecticide (X_4, X_5, X_3, X_{12}) were given over all periods, if any of these four attributes were going seriously wrong it would show up eventually somewhere else. The cost of logging could be deduced approximately from the profit figure and the unemployment level (which is proportional to wood harvested). This left profit, diversity, old trees, defoliation, dead trees, logging effects, and unemployment. It seems clear that all but the first and last are related to recreational, visual, and environmental considerations. If these five statistics could be combined into a single statistic of recreation, we would have:

P = Profit

U = Unemployment

R = Recreational value of forest

as attributes for each time period.

The general plan used by Clark for producing a recreational index involved combining the recreational potential of a region with an index of its visual quality. The recreational potential is a value assigned by the Canadian Forestry Commission to each region of the forest, indicating its accessibility to tourists and the quality of its surroundings (streams, lakes, gorges, and the like). Each region has a value of 0, 30, 70, or 100. Clark felt the defoliation (X_8), logging (X_{10}), old trees (X_7), and diversity (X_6) attributes were those that affected visual quality. He divided the possible range of each into three classifications: for example, for defoliation a stand with 0–15% defoliation was good, 15–45% medium, and 45–100% bad. A region was given a visual rating equal to the worst rating of its components. The final composition of recreational potential and visual quality was achieved by using the chart reproduced as Figure 18.1. Because some of the regions of the forest are not suitable for recreation under any conditions, the following are the number of regions possible in each recreation category.

$$0 \leq \text{Good} \leq 38$$

$$0 \leq \text{Medium} \leq 262$$

$$3 \leq \text{Bad} \leq 265$$

	0	30	70	100
GOOD	BAD	MEDIUM	GOOD	GOOD
MEDIUM	BAD	MEDIUM	MEDIUM	MEDIUM
BAD	BAD	BAD	BAD	BAD

FIGURE 18.1 Aggregation rule for recreational potential and condition.

Since the total number of regions is fixed (265) it is necessary to specify only two of the above classifications; hence the final list of statistics to be tabulated for each period is

- P = Profit
- U = Unemployment
- G = Number of good recreational regions
- B = Number of bad recreational regions

18.2 THE ASSESSMENT OF VALUE FUNCTION

The aim is now to derive a formula that takes the statistics (P_t, U_t, G_t, B_t) $t = 0, 1, 2, \dots$, and produces a value V such that if forest history α is preferred to forest history β , then

$$V(\alpha) > V(\beta).$$

Over recent years a great deal of research has gone into devising good techniques for the assessment of value functions (Keeney and Raiffa, 1976; Raiffa, 1969). These techniques were not tried on this problem. At the time of the study the methodology group at IIASA was experimenting with linear programming (LP) software and was eager for examples with which to work, so I combined our two aims and used the following linear programming approach to find value functions.

Consider a value function V having two variables x, y . Suppose the decision maker has said that in the following pairs he prefers the first one in each to the second: $(2, 5), (3, 0); (3, -7), (1, 1); (0, 2), (-1, 2)$. Thus

$$V(2, 5) - V(3, 0) > 0 \quad (18.2a)$$

$$V(3, -7) - V(1, 1) > 0 \quad (18.2b)$$

$$V(0, 2) - V(-1, 2) > 0. \quad (18.2c)$$

Suppose we approximate V with a quadratic polynomial

$$V(x, y) = ax + by + cxy + dx^2 + ey^2.$$

We find that

$$-a + 5b + 10c - 5d + 25e > 0 \quad (18.3a)$$

$$2a - 8b - 22c + 8d + 48e > 0 \quad (18.3b)$$

$$a + 2c - d > 0 \quad (18.3c)$$

are necessary requirements for V to be a valid function. Examples of polynomial expressions whose coefficients satisfy (18.3) are

$$V_1(x, y) = xy + y^2 \quad (18.4a)$$

$$V_2(x, y) = x + y^2 \quad (18.4b)$$

$$V_3(x, y) = -x^2 + y^2. \quad (18.4c)$$

By obtaining more pairs of preference orderings, the set of possible coefficient values (a, b, c, d, e) may be reduced; for example, if we now find that, in addition,

$$(3, 2) > (0, 3),$$

then only (18.4a) is still valid.

If there are many alternative value functions for a given data set, an LP algorithm will arbitrarily choose one of them unless it is given some selection criterion. Supplying an objective function for the LP problem means that with the same data set the LP will always choose the same value function; hence, as the data set alters slightly (because of new orderings), it is easier to see its effect on the resulting value function.

Note that if (a, b, c, d, e) is a solution of (18.3), then so is any positive multiple of it; hence the arbitrary constraint

$$|a| + |b| + |c| + |d| + |e| = 100$$

was added to bound the problem ($|a|$ means $+a$ if $a > 0$, $-a$ if $a < 0$).

The objective criterion used was to maximize the minimum gap between preference rankings. In the example above, the gaps between the left-hand side of (18.2) and the right-hand side (zero) using V_1 are 35, 26, 2; for V_2 they are 24, 51, 1; and for V_3 they are 30, 40, 1. Hence the minimum gap in each is 2, 1, 1, and so the maximum minimum gap is 2, and V_1 would be the preferred polynomial from that list.

In general, for a list of preferences

$$x_i^1 > x_i^2, \quad i = 1, 2, 3, \dots, k,$$

where $>$ reads "is preferred to," the full linear program would be

$$\begin{aligned} s^* &= \text{Max } s \\ \text{s.t.} \quad &V(x_i^1) - V(x_i^2) \geq s \quad i = 1, \dots, k \\ &|a| + |b| + |c| + |d| + \dots = 100. \end{aligned} \quad (18.5)$$

Note that a valid function exists if and only if $s^* > 0$. If $s^* \leq 0$, the decision maker is questioned more closely on doubtful orderings; if he is resolute, a higher-order approximation should be taken.

Returning to our study, with four attributes (P, U, G, B) per time period, two qualitative assumptions were made by Clark (with my prompting) that he felt to be reasonable (in the first case) or necessary (in the second).

1. Preferences for profit and unemployment were "independent" of those of recreation. That is, the relative orderings of (P, U) pairs were independent of the level of the recreation as long as it was the same in each case [for a discussion of preferential independence, see Keeney and Raiffa (1976, Chapter 6)]. The reverse was also felt to be true – i.e., that preferences for recreational alternatives were independent of profit/unemployment levels as long as these remained constant.

2. Clark's preferences for profit and unemployment levels in a year depended on what those levels were the year before and what they would be the next year. For example, a drop in profits to gain fuller employment is not too serious if compensated for by larger profits in the surrounding years. Also, an unemployment level of 10 percent is worse if it follows a year of full employment than if it follows a year of 10 percent unemployment; that is, he prefers a steady level to one that oscillates.

Clark felt that if we replaced P_t as a statistic with

$$Q_t = \frac{P_{t-1} + P_t + P_{t+1}}{3},$$

we might better justify a separable value function such as

$$V = \sum V_t(Q_t, U_t, G_t, B_t),$$

where V_t is a value function based on the figures for year t alone.

These assumptions enabled us to work with a value function

$$V_t(Q_t, U_t, G_t, B_t) = V_t[X(Q_t, U_t), Y(G_t, B_t)],$$

allowing us to calculate a value function for recreation independently of that for profit and unemployment.

It was implicitly assumed here that preferences were stationary, implying $X_t = X$ and $Y_t = Y$. Table 18.3 shows the rankings given by Clark for the two value functions X and Y for any time period. Note that for (Q, U) it is an ordered list and that the rankings for recreation include some equalities. The last three pairs in the recreation list were added when I discovered that the first polynomial expression was not suitably monotonic for extreme values. These rankings produce the following value functions:

$$X(Q, U) = 84.16Q + 2.26QU - 3.11Q^2 - 10.45U^2 \quad (18.6)$$

TABLE 18.3 Rankings for Value Functions X and Y

Ordered List of Socio- economic Indicators, X	Rankings between Pairs of Recreational Alternatives, Y	
	(Q, U)	(G_1, B_1) (G_2, B_2)
$(10, 0) >$	$(15, 50) >$	$(14, 0)$
$(0, 0) >$	$(25, 50) >$	$(24, 0)$
$(7, 8) >$	$(34, 0) >$	$(35, 50)$
$(20, 10) >$	$(26, 0) >$	$(38, 100)$
$(0, 5) >$	$(28, 100) =$	$(22, 0)$
$(4, 8) >$	$(28, 130) =$	$(16, 0)$
$(7, 10) >$	$(38, 227) =$	$(22, 50)$
$(-5, 0) >$	$(26, 200) =$	$(20, 150)$
$(30, 15) >$	$(4, 0) >$	$(1, 0)$
$(-5, 10) >$	$(0, 50) >$	$(0, 100)$
$(25, 25)$	$(30, 100) >$	$(25, 100)$

TABLE 18.4 Five Ordered Lists of All Four Indicators

$(Q,$	$U,$	$G,$	$B)$	$(Q,$	$U,$	$G,$	$B)$
10	0,	16,	30	10,	10,	16,	30
25,	0,	16,	100	25,	10,	16,	100
0,	0,	16,	0	0,	10,	16,	0
-5,	0,	16,	50	-5,	10,	16,	50
-5,	0,	0,	50				
				5,	0,	10,	50
5,	4,	16,	50	10,	0,	10,	100
5,	7,	16,	30	0,	0,	10,	30
5,	0,	16,	100	-5,	0,	10,	0
5,	10,	16,	0				
0,	10,	16,	0				
				5,	0,	10,	40
				10,	0,	2,	40
				0,	0,	16,	40
				-5,	0,	25,	40

and

$$Y(G, B) = (71.8 - 1.88G)G^2 - B^2(5.88 + .00134B) + GB(19.63 - 0.597G + 0.185B), \quad (18.7)$$

using a quadratic and a cubic polynomial approximation, respectively.

Clark then ordered sets of all four attributes as shown in Table 18.4. Each member of a group is preferred to the one below it. Using the functions (18.6) and (18.7), these lists may be reduced to lists of two attributes; for example, the first

list becomes

$$\begin{aligned} X(10, 0), Y(16, 30) \\ X(25, 0), Y(16, 100) \\ : \\ X(-5, 0), Y(0, 50). \end{aligned}$$

The cubic approximation technique was used again to find a combined value function of

$$\begin{aligned} V(X, Y) = 15.5Y^2 + 357XY + 48.8X^3 + 1.8X^2Y \\ - 9,050X^2 - 3,039,500X - 195,197Y. \end{aligned}$$

18.2.1 THE TIME PROBLEM

So far, the analysis has reduced the simulated history of the forest into a time stream of values, one per year. For two simulated histories with output values $(V_1^1, V_2^1, V_3^1, V_4^1, \dots)$ and $(V_1^2, V_2^2, V_3^2, V_4^2, \dots)$, it is reasonable to suppose that the decision maker prefers the first history to the second if $V_t^1 \geq V_t^2$ for all t and if this inequality is strict for some t . (Even this dominance argument is valid only because we are assuming that there are no interperiod dependencies of preferences. For example, we could imagine that the 5-year stream $(1, 2, 3, 4, 5)$ would be preferred to $(10, 9, 8, 7, 6)$ if the decision maker disliked drops from one period to the next.)

It is not yet possible for the analyst to say whether Clark would prefer a 5-year history $(2, 3, -1, 999, 7)$ to one of $(2, 3, -1, 4, 8)$ because we have no rules for intertemporal trade-offs. The only manageable model for such trade-offs is a linear assumption that

$$V = \sum \alpha_t V(Q_t, U_t, G_t, B_t)$$

for some coefficients α_t , where, presumably, $\alpha_t \geq \alpha_{t+1} \geq 0$ for all t .

Had time permitted (Bill Clark returned to Canada at this point), we could have found viable values for the coefficients α_t by using the same technique that led to the coefficients in the second value function

$$V[X(Q, U), Y(G, B)].$$

However, at this stage we agreed that the simulation model should generate different histories using a variety of policies and should calculate the value

$$V = \sum \alpha^t V(Q_t, U_t, G_t, B_t)$$

for a range of values of the constant α , $0 < \alpha < 1$.

18.3 THE ASSESSMENT OF A UTILITY FUNCTION

Even if we ignore the crude manner in which the time streams of the attributes were evaluated, there remains another important element in the effective evaluation of policies by use of an objective function. The particular history generated by the simulator depends upon the initial condition of the forest, the many complex equations governing the growth of budworm and of trees, and the effects of predators and other factors, but all of these are deterministic only if the weather pattern is known. Different weather patterns will produce different histories, and hence a policy cannot be judged purely on the results of one run; its effects must be considered under all types of weather futures. Fortunately, this problem may be overcome if a utility function, which is a special type of value function, is used. Not only does a utility function have the properties of a value function, but in situations in which outcomes are uncertain its expected value provides a valid quantity for making rankings.

That is, if $u(P, W)$ represents the utility (or value) of the forest history that results from using policy P when weather history W occurs and $f(W)$ is the probability that weather pattern W does occur, then

$$\sum u(P, W) f(W) = V(P),$$

where the sum is taken over all possible weather patterns, is a legitimate value function over policies P .

Assessment procedures for utility functions are similar to those for value functions except that the decision maker's attitude towards risk taking must be incorporated. As with value functions, it is useful to recognize assumptions that will break down the assessment of one function with many attributes into one of assessing several utility functions, each having only one or two attributes.

The assumptions that allowed the breaking down of the utility function into utility functions of, at most, two attributes are described in the following sections. In section 18.3.1 the general approach toward assessing the utility function is outlined, and how it is broken down over time and across the attributes is described. Section 18.3.2 deals with the recreation attributes and shows how this assessment was also made easier by making certain assumptions. Section 18.3.3 then details the assessment of a utility function for the profit and unemployment attributes. First, however, an outline of the basic independence assumption to be used throughout the remainder of the paper is given.

This assumption is utility independence. For a utility function $u(x, y)$, where x and y might be vectors of attributes, if the decision maker's attitude toward risk taking in situations where only the outcome of x is uncertain but y is fixed and known is independent of what that fixed value of y is, then attributes X are said to be utility independent of Y . It is important to realize that X may be utility independent of Y even if X and Y involve factors that in other respects are closely

related. [For more information and examples see Keeney and Raiffa (1976, Chapter 5).] The functional statement of this property is that for any two values of Y (y^1 and y^2 , for example)

$$u(x, y^1) = a + b u(x, y^2)$$

for some constants a and b , where b must be positive.

In our problem, which has four attributes per year with a horizon of T periods (T will be in the range 50–200), we require a utility function of $4T$ attributes; thus, some extensive assumptions will be required. Meyer (1970), for example, has shown that for a utility function $u(x_1, x_2, \dots, x_T)$ if each subset of attributes $\{X_1, \dots, X_t\}$ is considered to be utility independent of $\{X_{t+1}, \dots, X_T\}$ and vice versa, then the utility function has either an additive form

$$\sum_{t=1}^T a_t u_t(x_t) \quad (18.8)$$

for some positive constants a_t or a multiplicative form

$$\prod_{t=1}^T [b_t + c_t u_t(x_t)] \quad (18.9)$$

for some constants b_t and c_t , where in each case $u_t(x_t)$ is a utility function over X_t alone.

These forms were inappropriate for our case principally because Clark's attitude toward risk taking for levels of unemployment in one period depended on the levels of unemployment in the year before and the year after, and hence Meyer's assumptions of utility independence did not apply. Also, Clark wished to make an assumption of stationarity (see Koopmans, 1960); that is, he wished to treat all years equally, with regard to both value orderings and risk taking. This meant that the coefficients a_t , b_t , c_t and the functions u_t in (18.8) and (18.9) would have to be independent of their suffix t , implying that all time streams that were merely permutations of one another would be assigned equal utility, which was not the case. For example, in dealing only with levels of employment, he preferred the stream (100, 100, 90, 90, 100) to (100, 90, 100, 90, 100) because of the reduced variance between years. (So that the symbol u would not be used simultaneously for utility and a level of unemployment, we now use "employment," rather than "unemployment"; $E_t = 100 - U_t$ is the new attribute.)

Fishburn (1965) used assumptions called Markovian dependence to produce a form

$$u(x_1, \dots, x_T) = \sum_{t=1}^T u_t(x_t, x_{t+1}) - \sum_{t=2}^{T-1} u_t(x_t, x_{t+1}^0), \quad (18.10)$$

where $u_t(x_t, x_{t+1})$ is a utility function over the two attributes x_t, x_{t+1} . While this does allow for some interdependency between attributes in neighboring periods,

Clark was quite firm in preferring the lottery

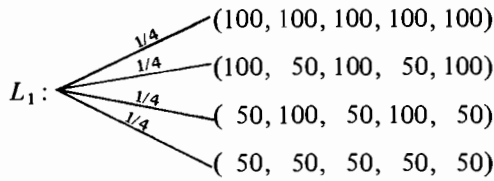

to the lottery

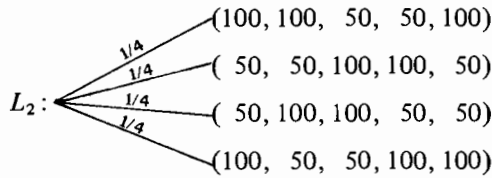

where the figures are percentage of employment in 5 successive years. For (18.10) to be valid for Clark's preferences, he should have been indifferent between the two lotteries.

18.3.1 FINDING APPROPRIATE ASSUMPTIONS

To find a form of the utility function that would be acceptable to him, I considered assumptions involving conditional utility independence. This condition says, in essence, that if the set of attributes is divided into three parts X , Y , and Z , then X is conditionally utility independent of Y if, whenever Z is fixed at some level and we regard the problem as now having only two attributes X and Y , X is utility independent of Y and that this is true for all fixed values of Z . [For more detailed expositions of this concept see Keeney and Raiffa (1976, Chapter 6) or Bell (1975).]

The idea was to assume that each subset $\{X_1, \dots, X_{t-1}\}$ was conditionally utility independent of $\{X_{t+1}, \dots, X_T\}$ and vice versa. This is quite similar to the assumptions used by Meyer to obtain (18.8) and (18.9), but there is no assumption of independence of preferences for X_t on either X_{t-1} or X_{t+1} .

These assumptions led (for $T \geq 4$) to the conclusion that either

$$u(x_1, x_2, \dots, x_T) = \sum_{t=1}^{T-1} u_t(x_t, x_{t+1}) - \sum_{t=2}^{T-1} u_t(x_t, x_{t+1}^0) \quad (18.11)$$

or

$$u(x_1, x_2, \dots, x_T) = \left(\prod_{t=2}^{T-1} [\lambda + u_t(x_t, x_{t+1}^0)] \right)^{-1} \left(\prod_{t=1}^{T-1} [\lambda + u_t(x_t, x_{t+1})] \right) - \lambda \quad (18.12)$$

where λ is a constant and

$$u_t(x_t, x_{t+1}) \equiv u(x_1^0, x_2^0, \dots, x_{t-1}^0, x_t, x_{t+1}, x_{t+2}^0, \dots, x_T^0)$$

where x_i^0 is any fixed value of X_i , so that, for example, $u_t(x_t^0, x_{t+1}) = u_{t+1}(x_{t+1}, x_{t+2}^0)$, and where u was scaled so that $u(x_1^0, \dots, x_T^0) = 0$. For a proof of this result see Bell (1975). Note that (18.11) is exactly (18.10) but that (18.12) not only allows interperiod dependencies but also is able to differentiate between the lotteries L_1 and L_2 .

Bill Clark returned to IIASA for the summer of 1975, and I quizzed him on the appropriateness of the assumptions that led to (18.12). He agreed that they seemed appropriate, and so we proceeded to assess his utility function over the attributes $\{P_t, E_t, G_t, B_t\}$, $t = 1, \dots, T$.

Questioning soon established that his preferences for the recreation time streams $\{G_1, B_1, G_2, B_2, \dots, G_T, B_T\}$ were mutually utility independent of those for the time streams of profit and employment $\{P_1, E_1, P_2, E_2, \dots, P_T, E_T\}$, enabling us to use the formula (see Keeney, 1972)

$$u(p, e, g, b) = u_R(g, b) + k_1 u_S(p, e) + k_2 u_R(g, b) u_S(p, e), \quad (18.13)$$

where u_R is a utility function for recreation and u_S a social utility function and k_1 and k_2 are constants (k_2 was later identified as zero). I should emphasize that Clark was not one to make assumptions merely because of expediency: whenever he agreed that an assumption was valid, we had discussed the implications at length and verified that his preferences reflected the required pattern or were sufficiently close to allow its acceptance.

18.3.2 THE UTILITY FUNCTION FOR RECREATION

For the recreation streams, Clark felt that the assumptions of Meyer were appropriate and, in addition, that in any given time period G_t and B_t were mutually utility independent. To determine whether the additive form (18.8) or multiplicative form (18.9) was the appropriate one to use, I asked him if he had any preference between the following two lotteries

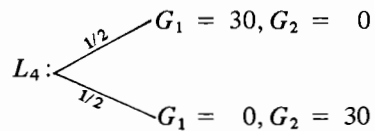
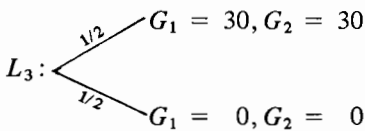

where G_1 and G_2 are the number of good recreational areas in two successive years and B_1 and B_2 are in all outcomes assumed to be fixed. (Recall that because G_t and B_t are mutually utility independent, it is not necessary to specify at what level B_1 and B_2 are fixed.) If the additive form (18.8) was appropriate, he should have been indifferent between the two, but in fact he preferred the second lottery on the grounds that he was very averse to having two very bad years together. This meant that the form of the recreational utility function was

$$u_R(g, b) = \prod_{t=1}^T (\alpha + \beta [k_1 + k_2 u_G(g_t) + k_3 u_B(b_t) + k_4 u_G(g_t) u_B(b_t)]), \quad (18.14)$$

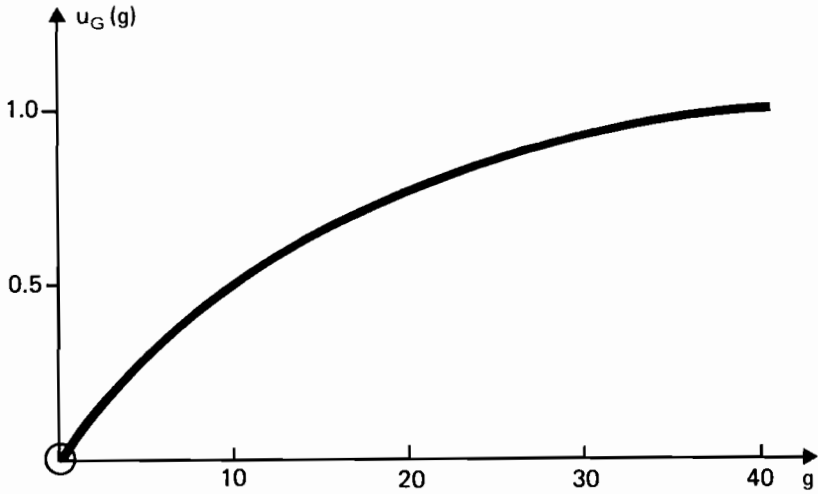

FIGURE 18.2 Utility function for the number of good recreational areas.

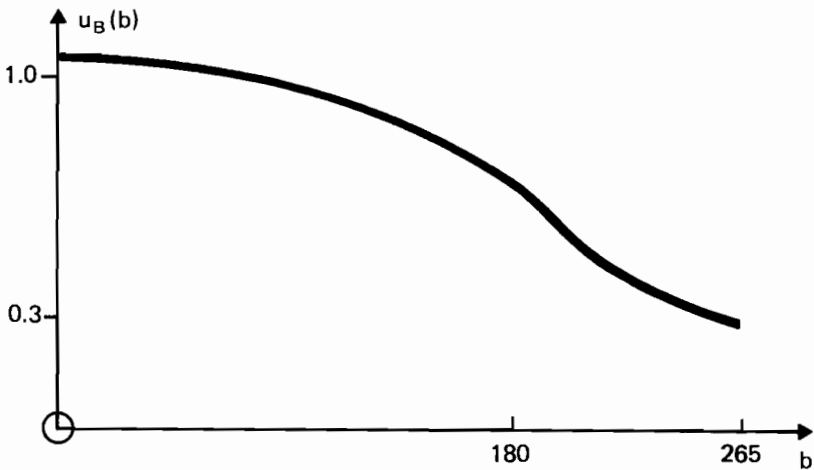

FIGURE 18.3 Utility function for the number of bad recreational areas.

where the various constants are independent of the time subscript because of the assumption of stationarity.

The marginal utility functions u_G and u_B for the number of good and bad areas were assessed in the usual manner (see, for example, Raiffa, 1969) by asking questions of the form “what value $G = g^*$ for certain do you feel is equally preferable to a 50–50 gamble between $G = 20$ and $G = 5$?”

Thus $u_G(g)$ was assessed as in Figure 18.2 which was fitted quite closely by the exponential curve $u_G(g) = 1 - \exp(-0.08g)$. The function $u_B(b)$ was slightly more

complicated (Figure 18.3), being fitted in two pieces by

$$u_B(b) = 0.7 + 0.35 [1.0176 - 0.0176 \exp(0.0225b)] \quad b < 180$$

$$u_B(b) = -0.3 + 0.35 [+1.463 + 28.222 \exp(-0.0164b)] \quad b \geq 180$$

The constants k_1, k_2, k_3, k_4 were calculated by fixing

$$k_1 + k_2 u_G(40) + k_3 u_B(0) + k_4 u_G(40) u_B(0) = 1 \quad (18.15a)$$

and

$$k_1 + k_2 u_G(0) + k_3 u_B(265) + k_4 u_G(0) u_B(265) = 0 \quad (18.15b)$$

and then using indifferent pairs given by Clark:

$$(20, 150) \sim (9, 0) \quad (18.16a)$$

$$(15, 100) \sim (25, 150) \quad (18.16b)$$

$$(7, 0) \sim (15, 150) \quad (18.16c)$$

to form three more equations in the k_i 's. Also, since Clark always prefers to increase the number of good areas if possible, the constraint

$$k_2 + k_4 u_B(b) > 0 \quad (18.17)$$

should be true for all b , and for similar reasons

$$k_3 + k_4 u_G(g) > 0 \quad (18.18)$$

for all g . Examining the implications of (18.15) to (18.18), we found that the set of coefficients

$$k_1 = -1.201 \quad k_2 = -0.291 \quad k_3 = 0.356 \quad k_4 = 0.905$$

were a very good fit to our information.

To finalize the recreational utility function now required only the knowledge of α and β in (18.14). For this I asked him to consider a time stream in which all values after year 2 are assumed fixed; the number of bad areas is fixed at 100 for years 1 and 2. So, considering only vectors of the type (number of good areas in year 1, number of good areas in year 2), he was to give values g_1, g_2, g_3, g_4, g_5 such that

$$(g_1, g_1) \sim (15, 5); (g_2, g_2) \sim (20, 5); (g_3, g_3) \sim (25, 5); (g_4, g_4) \sim (30, 5);$$

$$(g_5, g_5) \sim (35, 5) \quad (18.19)$$

His answers were 9, 10, 12, 14, and 15, respectively. In attempting to solve (18.14) with this information it became clear that in fact it is the additive form (18.8) rather than the multiplicative form that fits (18.19). When I referred this apparent inconsistency back to Clark, we established that his preference between the lotteries L_3 and L_4 was caused by the extreme nature of the consequence in L_3 of two successive years with zero good recreational areas. When I replaced the zeros in

L_3 and L_4 with something positive, he became indifferent. Perhaps this should indicate a singularity in the function u_G at $G=0$, but I chose to ignore this.

Thus, the recreational utility function was established as

$$u_R(g, b) = \sum_{t=1}^T \{0.356 u_B(b_t) + [0.905 u_B(b_t) - 0.291] u_G(g_t)\}. \quad (18.20)$$

18.3.3 THE SOCIAL UTILITY FUNCTION

When Clark had accepted the conditional utility independence assumptions necessary to validate the use of equation (18.12), we chose fixed levels of $p_t^0 = 0$ million dollars per year and $e_t^0 = 100$ percent employment. The main task was thus to assess, for each $t = 1, 2, \dots, T-1$, the function

$$u_S(p_1^0, e_1^0, \dots, p_{t-1}^0, e_{t-1}^0, p_t, e_t, p_{t+1}, e_{t+1}, p_{t+2}^0, e_{t+2}^0, \dots, p_T^0, e_T^0),$$

or, in a shorthand notation where we omit explicit reference to attributes at their fixed values, $u_S(p_t, e_t, p_{t+1}, e_{t+1})$. While previous assumptions about independence between attributes had either been elicited through questioning or had been prompted by me, on this occasion Clark volunteered that when considering his preferences for employment in a given year, he was concerned only with the levels of profit in the same year and the levels of employment in the preceding and following years, and that his preferences for profit in a given year depended only upon the level of employment in that year. This implied that for the attributes $P_t, E_t, P_{t+1}, E_{t+1}$ we could assert that P_t was mutually conditionally utility independent (MCUI) with P_{t+1} and E_{t+1} and, similarly, that P_{t+1} was MCUI with P_t and E_t . This set of additional assumptions proved to be most useful. Consider the assumptions leading to (18.11) and (18.12) for $T=4$. In full, they are X_1 MCUI $\{X_3, X_4\}$ and $\{X_1, X_2\}$ MCUI X_4 . Those that Clark had proposed were P_t MCUI $\{E_{t+1}, P_{t+1}\}$ and $\{P_t, E_t\}$ MCUI P_{t+1} , showing that (18.11) or (18.12) was appropriate for the restricted function $u_S(p_t, e_t, p_{t+1}, e_{t+1})$.

It is easy to show (set all attributes at their fixed level except for P_2) that the assumption of stationarity forces both $u_S(p_t, e_t, p_{t+1}, e_{t+1})$ and the full function $u_S(p, e)$ either to be additive or to be multiplicative and, if multiplicative, to have the same parameter λ . The nonindifference between lotteries L_1 and L_2 showed the multiplicative form to be the appropriate one. Hence, using all the declared independence assumptions, the social utility function could be expressed as

$$u_S(p, e) = \frac{\prod_{t=1}^T [\lambda + u_A(p_t, e_t)] \prod_{t=1}^{T-1} [\lambda + u_E(e_t, e_{t+1})]}{\prod_{t=1}^T [\lambda + u_E(e_t, e_{t+1}^0)] \prod_{t=2}^{T-1} [\lambda + u_E(e_t, e_{t+1}^0)]} - \lambda \quad (18.21)$$

for some constant λ , where u_A and u_E are each two attribute utility functions for which $u_A(p_t^0, e_t) = u_E(e_t, e_{t+1}^0) = u_E(e_{t-1}^0, e_t)$. Thus the solution of the assessment problem rested on finding u_A , u_E , and λ .

The Interperiod Employment Function

We began with u_E . Recall that $u_E(e_t, e_{t+1})$ is, in effect, $u_S(p^0, e_1^0, \dots, e_{t-1}^0, e_t, e_{t+1}, e_{t+2}^0, \dots, e_T^0)$ so that, when questioned about his preferences, Clark was to compare employment streams of the form $(100, 100, \dots, 100, e_t, e_{t+1}, 100, \dots, 100)$. I proceeded by fixing the level of E_t at some value e_t and then assessing the one attribute function $u_1(e_{t+1} | E_t = \bar{e}_t)$. It appeared that for lotteries involving levels of E_{t+1} that were higher than \bar{e}_t he was risk averse but that he was risk prone for levels of E_{t+1} lower than \bar{e}_t . The reason was that the previous year's employment level represented a goal or aspiration level for the present year, part of his desire for stability in employment levels. The only departure from this was that if I fixed \bar{e}_t at anything higher than 80 percent he was never risk prone for values of $e_{t+1} \geq 80$, because any year in which employment was at least 80 percent was "satisfactory." Hence his "goal" was $\min \{\bar{e}_t, 80\}$. A typical graph of $u_1(e_{t+1} | E_t = \bar{e}_t)$ is shown in Figure 18.4.

The two-piece function was fitted again quite closely by an exponential curve of the form

$$-\exp\{-0.03 e_{t+1}\} \quad e_{t+1} \geq \min\{80, \bar{e}_t\} \quad (18.22a)$$

and

$$-\exp\{+0.03 e_{t+1}\} \quad e_{t+1} \leq \min\{80, \bar{e}_t\}. \quad (18.22b)$$

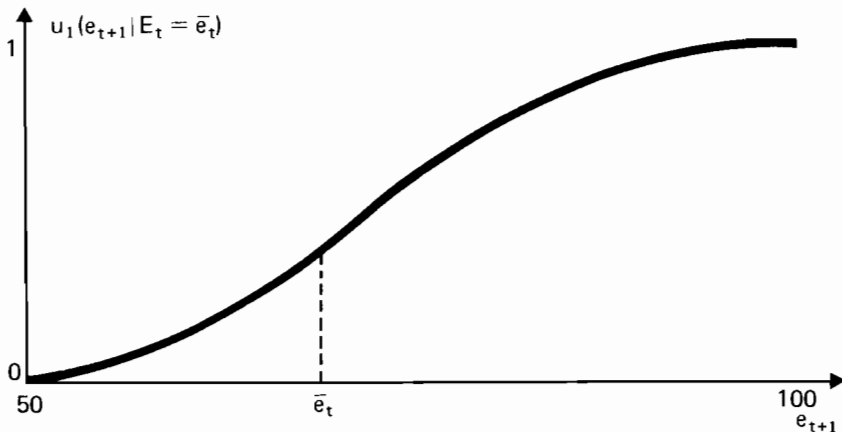

FIGURE 18.4 Utility function for employment, conditional on the level of employment in the previous year.

In a similar way $u_2(e_t | E_{t+1} = e_{t+1})$ was assessed, and it exhibited many of the same features. Since E_{t-1} was fixed at 100, there was a desire to achieve this goal with e_t , but this was tempered by the opposite desire not to exceed \bar{e}_{t+1} . The result seemed to be that Clark preferred the pattern (100, 80, 90, 100) to (100, 90, 80, 100); although a drop from 100 to 80 was serious, it was better to suffer that and follow it with 2 years of improvement than be faced with 2 years of falling employment, even though this was ultimately followed by an increase from 80 to 100. The function $u_2(e_t | E_{t+1} = \bar{e}_{t+1})$ was of the form

$$\text{and} \quad \begin{aligned} & -\exp\{-0.03 e_t\} & e_t \geq \min\{80, \bar{e}_{t+1} - 5\} & (18.23a) \\ & -\exp\{+0.03 e_t\} & e_t \leq \min\{80, \bar{e}_{t+1} - 5\}. & (18.23b) \end{aligned}$$

The exponential coefficients in (18.22) and (18.23) are all shown equal to 0.03 because they were all fairly close and the implications seemed insensitive to this parameter.

To obtain the combined function $u_E(e_t, e_{t+1})$ I used the fact that

$$\text{and} \quad u_E(e_t, e_{t+1}) = f(e_{t+1}) + g(e_{t+1}) u_2(e_t | E_{t+1} = e_{t+1}) \quad (18.24)$$

$$u_E(e_t, e_{t+1}) = h(e_t) + k(e_t) u_1(e_{t+1} | E_t = e_t) \quad (18.25)$$

for some functions f, g, h, k . Solving these gives

$$\begin{aligned} & [u_2(e_t^0 | e_{t+1}) - u_2(e_t^* | e_{t+1})] u_B(e_t, e_{t+1}) \\ & = [a_1 + a_2 u_1(e_{t+1} | e_t^*)] [u_2(e_t^0 | e_{t+1}) - u_2(e_t | e_{t+1})] \\ & \quad - [a_3 + a_4 u_1(e_{t+1} | e_t^0)] [u_2(e_t^* | e_{t+1}) - u_2(e_t | e_{t+1})], \end{aligned} \quad (18.26)$$

where a_1, a_2, a_3, a_4 were constants calculated in much the same manner as the constants k_1, k_2, k_3, k_4 were calculated for the recreational function, and $e_t^* \neq e_t^0$ was any constant, chosen to be 50.

The Profit–Employment Trade-offs

The next step was to calculate $u_A(p_t, e_t)$. This could have been done in the same way as u_E was calculated, but Clark found it easier to think in terms of indifference curves between p_t, e_t pairs. Hence, on graph paper with axes of e_t from 50 to 100 and of p_t from -10 to $+30$, we located on it pairs $(p_t^1, e_t^1), (p_t^2, e_t^2)$ between which Clark was indifferent, again bearing in mind that all other attributes were at their fixed levels, and then fairing in sample indifference curves. The result is exhibited in Figure 18.5.

What was delightful to me as the analyst was that if we describe the above indifference curves by the functional relationship

$$\phi(p_t, e_t) = \text{constant}$$

for varying constants, it was empirically observable that

$$\phi(p_t^1, e_t^1) = \phi(p_t^2, e_t^2) \Leftrightarrow \phi(p_t^1, e_t^1 + \epsilon) = \phi(p_t^2, e_t^2 + \epsilon) \quad (18.27)$$

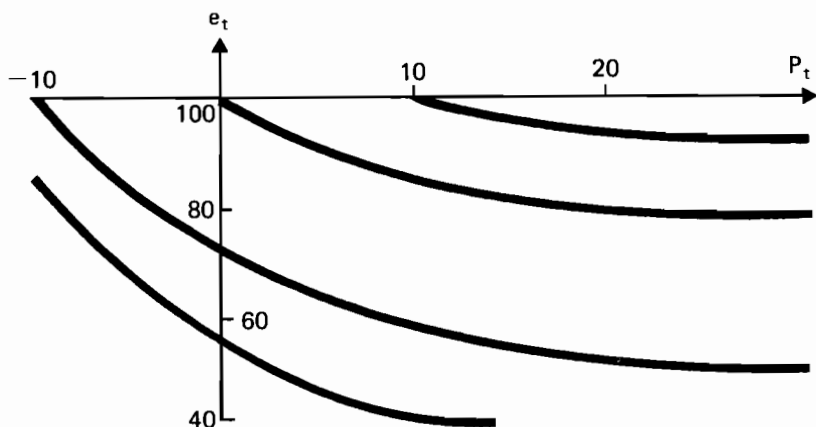

FIGURE 18.5 Profit-employment indifference curves for a single year.

for all values of ϵ . This meant that quantification of ϕ was easy. I used a polynomial curve-fitting program on one of the indifference curves and found that a quadratic was sufficiently accurate; substituting in the other curves confirmed directly the visual observation that property (18.27) held. [For an example of this property in connection with time streams, see Bell (1974).]

The indifference curves were

$$\phi(p_t, e_t) = e_t + 1.9 p_t - 0.04 p_t^2 = \text{constant}.$$

The next task was to assess a utility function over ϕ , the value function. Using the indifference curves, any pair (p_t, e_t) could be replaced by an equivalent pair $(p_t^*, 100)$ where $\phi(p_t^*, 100) = \phi(p_t, e_t)$ or

$$p_t^* = 23.75 - \frac{1}{2} \sqrt{2,256.3 + 100(100 - e_t) - 190 p_t + 4 p_t^2}.$$

The one-dimensional utility function $u_A(p_t, 100)$ had earlier been assessed in the usual manner in the range -8 to $+26$, the result depicted in Figure 18.6.

Recall that if Clark has been consistent, we should be able to observe that $u_A(0, e_t) = u_E(e_t, 100)$. As a check I calculated the implied function $u_A(p_t, 100)$ using $u_E(e_t, 100)$ and $\phi(p_t, e_t)$. Actually, comparison was possible only between $-8 \leq p_t \leq 0$, but here the agreement was close. The full implied function $u_A(p_t, 100)$ is shown in Figure 18.7 for $p_t \leq 0$.

Note that because $\phi(-9.15, 100) = \phi(0, 80)$, the implied function $u_A(p_t, 100)$ becomes risk prone for $p_t \leq -9.15$. From the point of view of a consistency check, we were perhaps fortunate that the direct assessment of $u_A(p_t, 100)$ did not involve a range that low.

For later calculations the value of $u_A(p_t, e_t)$ was taken to be

$$1 - \exp[-0.055 p_t^*] \quad \text{for } \phi(p_t, e_t) \geq 100$$

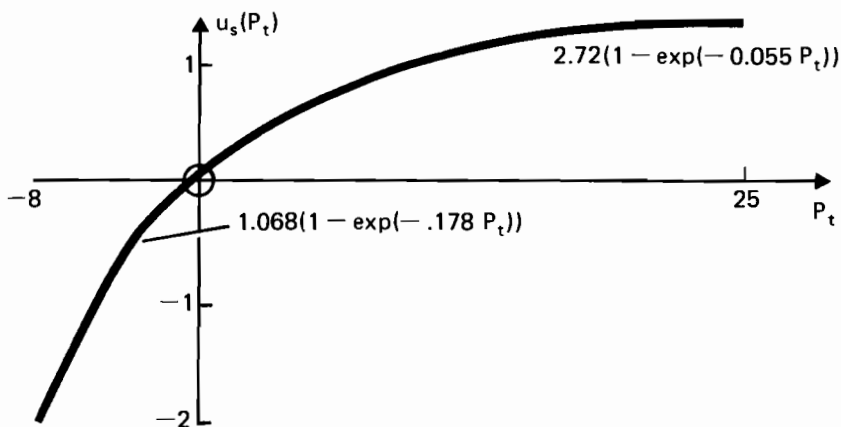

FIGURE 18.6 Marginal utility function for a single year's profits.

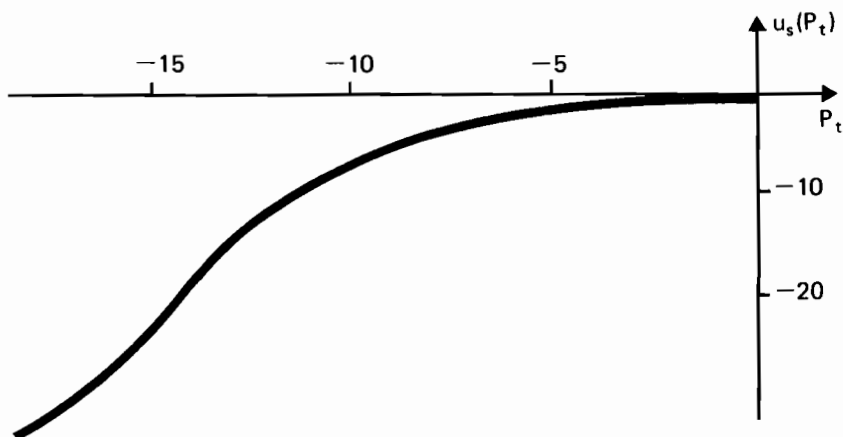

FIGURE 18.7 Marginal utility function for profit implied by Figures 18.4 and 18.5.

where

$$\phi(p_t^*, 100) = \phi(p_t, e_t)$$

and

$$u_E(e_t^*, e_{t+1}^0) \text{ for } \phi(p_t, e_t) < 100$$

where

$$\phi(0, e_t^*) = \phi(p_t, e_t).$$

The functions u_A and u_E were scaled so that $u_A(0, 100) = u_E(100, 100) = 0$ and $u_A(0, 50) = u_E(50, 100) = u_E(100, 50) = -1$.

Evaluating the Constant λ

To complete the assessment of $u_S(p, e)$ it remained to calculate λ , the constant in equation (18.21). What this constant controls is the degree to which the decision maker prefers a mixture of good years and bad years to appear in bunches or interspersed. I began by asking Clark how, if he had to arrange 50 good years and 50 bad years in a sequence of 100, he would do it. Recall that if we were not using functions with interperiod dependencies, such a question would not arise since all permutations would be equally preferred because of Clark's "no-discounting" policy. He certainly disliked both the options in which good and bad alternated and in which all 50 good years came together. As $1/\lambda$ becomes larger, the tendency is for the utility function to prefer smaller blocks, and as it becomes smaller (and negative), to prefer the large bunching.

I asked Clark to consider the following four streams of 7-year employment figures

- (i) 100, 100, 70, 70, 70, 100, 100
- (ii) 100, 70, 70, 70, 70, 100, 100
- (iii) 100, 70, 70, 70, 70, 70, 100
- (iv) 100, 70, 70, 100, 70, 70, 100

and to tell me what statements he could make about his preferences among them. He established that (i) was the best and (iii) the worst and felt that (iv) was preferable to (ii) "if anything." Using this information I drew a graph (Figure 18.8) that showed the utility of (i) fixed at 1, the utility of (iii) fixed at zero, and the corresponding utilities of (ii) and (iv) as functions of $1/\lambda$ using (18.21). Note that $1/\lambda = 0$ corresponds to the additive case (18.11).

The near indifference of (ii) and (iv) suggested that $1/\lambda$ should be chosen to be about 1, but there were other considerations. In order to avoid discontinuities in $u_S(p, e)$, $\lambda + u_E(e_t, e_{t+1})$ and $\lambda + u_A(p_t, e_t)$ must always be either both negative or both positive. If both positive, then

$$\lambda \geq \max \{-u_E(50, 50), -u_A(-20, 50)\}$$

is a constraint, and if both negative, then

$$\lambda \leq \min \{-u_E(100, 100), -u_A(20, 100)\}.$$

Clearly, it is the former case that is appropriate here, and so $\lambda \geq 1.487$ or $1/\lambda \leq 0.6735$. From Figure 18.8, it can be seen that if he is to be consistent, Clark should prefer (ii) to (iv). He also felt that he would prefer (iv) to a 50-50 gamble between (i) and (iii), which with the existing function u_E is never possible. This discrepancy was not resolved. Clark later decided that the answer to the question of sequencing 50 good and 50 bad years was to do it in alternating 4-year blocks. This answer contradicts his preference of (iv) over (ii). As the minicomputer I was using only

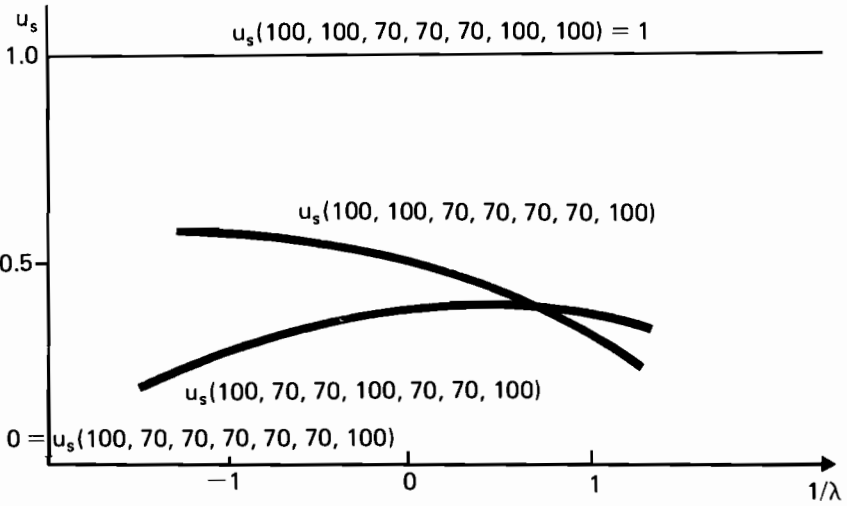

FIGURE 18.8 Relative utilities of four time streams as λ varies.

allowed time streams of up to 10 years, I could not experiment with graphs such as Figure 18.8 for longer blocks, but this should be possible in future. A value of $\lambda = 1.61$ is currently being used.

18.3.4 THE BALANCE BETWEEN RECREATION AND SOCIAL BENEFITS

Everything was now reduced to finding the constants k_1 and k_2 of formula (18.13):

$$u(p, e, g, b) = u_R(g, b) + k_1 u_S(p, e) + k_2 u_R(g, b) u_S(p, e). \quad (18.28)$$

The constant k_2 was quickly established as zero because Clark felt that lotteries of the following type

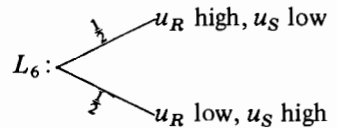
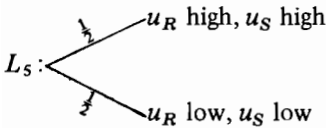

were indifferent. Actually, over the period of the analysis he alternated between the following two arguments:

1. When unemployment is high, the people should at least be able to spend their enforced free time enjoying the forest, and when business is booming, bad recreational facilities can be overlooked. At least *something* should be good.
2. It is probably not the unemployed who do take advantage of weekends in the forest, and in any case the forest as a recreational area serves a far greater

number of people than are associated with the logging industry. Hence there is likely to be an outcry if people notice high profits in the logging business and poor recreation.

Argument 1 favors L_6 and argument 2 favors L_5 . He finally decided on indifference. Thus $k_2 = 0$.

Since, in some sense, k_1 now embodies the trade-off to be made between "profits" and "environment," some care was necessary in its calculation. First I asked for a profit level x such that for a single year

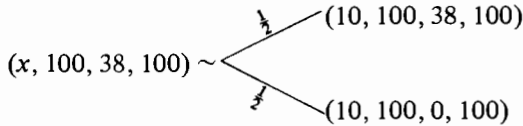

where the vectors are (P_t, E_t, G_t, B_t) , all other periods being assumed to be at fixed values, and for a number of good areas y such that

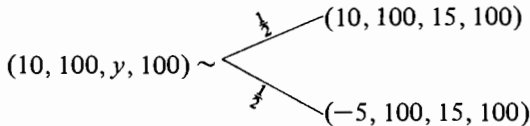

His answers of $x = -3$ and $y = 6$ yielded, after substitution in (18.28), the values $k_1 = 7.9$ and $k_1 = 5.0$. To provide further evidence, I asked for a number of bad areas z such that $(0, 100, 15, z)$ was indifferent to $(0, 95, 15, 100)$ and a level of employment w such that

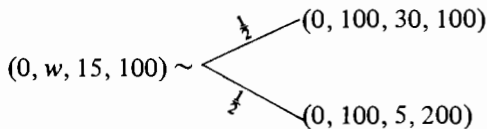

His answers here were $z = 155$ and $w = 90$, giving $k_1 = 9.4$ and 5.3 , respectively.

I felt his answer x was the most reliable and w the least reliable (because of the difficult trade-offs involved), and so $k_1 = 7.5$ seemed an appropriate compromise.

18.4 A SUMMARY OF THE ASSUMPTIONS

Let us review all the assumptions that were used concerning the decision maker's preferences over the attributes $\{P_1, E_1, G_1, B_1, \dots, P_T, E_T, G_T, B_T\}$. Recall that the mathematical result of asserting that attribute(s) X is conditionally utility independent of Y when Z is fixed is that for any values x, y, z of X, Y, Z and some fixed value y^0 of Y

$$u(x, y, z) = f(y, z) + g(y, z) u(x, y^0, z)$$

for some functions f, g . Utility independence is the special case that obtains when the set Z is empty.

The assumptions made were the following:

- The attributes $\{P_1, E_1, P_2, E_2, \dots, P_T, E_T\}$ are mutually utility independent, with $\{G_1, B_1, G_2, B_2, \dots, G_T, B_T\}$.
- For each $t = 1, \dots, T-2$, the set $\{P_1, E_1, P_2, E_2, \dots, P_t, E_t\}$ is mutually conditionally utility independent, with $\{P_{t+2}, E_{t+2}, \dots, P_T, E_T\}$.
- For each $t = 1, \dots, T-1$, P_t is mutually conditionally utility independent, with $\{P_{t+1}, E_{t+1}\}$, and P_{t+1} is mutually conditionally utility independent, with $\{P_t, E_t\}$.
- For all $t = 1, \dots, T-1$, $\{G_1, B_1, G_2, B_2, \dots, G_t, B_t\}$ is mutually conditionally utility independent, with $\{G_{t+1}, B_{t+1}, \dots, G_T, B_T\}$.
- For all $t = 1, \dots, T$ G_t is mutually conditionally utility independent, with B_t .
- Preferences over time are stationary; that is, ignoring end effects, if the time index in any situation were altered by an equal constant amount for all outcomes, relative preferences would be unaffected.

The assumptions need not be as strong as this to imply the functional form used, but since (18.21) and (18.28) together imply all of the above, it seems worthwhile to state them in full.

18.5 THOUGHTS ON THE WHOLE PROCEDURE

The study described here gradually shifted in emphasis from my casual curiosity about the profit–environment trade-offs of the IIASA ecology group to an eagerness by that group to obtain an objective function with which to evaluate policies and finally to a searching examination by Clark of the ability of “decision analysis” to handle complex problems.

It could be that little more will be gained in terms of establishing better management policies using the complex objective function assessed here than would be the case if the original linear function were maintained. But if the policy evaluations are different, then this study will have achieved a great deal. Attention can then be focused on the reasons for the differences, and the implications resolved.

The ecology project members have benefited from this study by having to discuss in concrete terms (seemingly for the first time) their precise objectives — “what they want out of their forest.” It is remarkable how the members of a group who apparently agree “in principle” can differ diametrically when it comes to quantification.

I began this study as an advocate of decision analysis as a means of raising important issues in a decision context but as a skeptic when it came to its ability

to deal with anything more complicated than the handling of minor monetary decisions with uncertain payoffs; my own interest was to see what I could do with the theory in a "real" situation. I am encouraged. With more practice, many of the errors and much of the lack of sophistication can be eliminated in future studies. For example, I would concentrate much more on extracting information about which the decision maker was sure at an early stage. After a long period of questioning, decision making seems to become harder for the decision maker rather than easier. I would be inclined to keep questions that involve uncertainty to a minimum, as a good feel for probability is rather rare — my decision maker flatly refused to discuss any lottery that was not a case of an equal probability for each consequence. In theory it is possible first to evaluate a value function over all the attributes and then to assess a single one-attribute utility over that value function; this is a bit extreme, however, as it sacrifices much of the structure offered by the utility independence concepts.

I was also initially skeptical about the extent to which simplifying assumptions were "natural" as opposed to being forced on an unwilling decision maker as a matter of expediency. It certainly appears that such assumptions are often empirically observable or are sufficiently closely approximated that little accuracy is lost. After all, much of the weighting between different outcomes stems from the major constants such as k_1 and k_2 in (18.28) and λ in (18.21) rather than, say, the particular choice of coefficient for the exponential curve fitted to $u_G(g)$.

As a practical matter, because this study was conducted in a part-time on-off fashion over 18 months, it was inevitable that the decision maker's preferences gradually altered over time; combined with my own frequent numerical and programming errors, this meant that I was often forced to start from the beginning and rework most of the calculations. It was only toward the very end of the study that I learned to save the Fortran programs that performed many of these calculations. Because of this oversight, many of the early assessments were not reworked or subjected to a sensitivity analysis. A golden rule for those undertaking any major assessment that is likely to involve complex trade-offs is to program everything!

REFERENCES

- Bell, D.E. 1974. Evaluating time streams of income. *Omega*, Vol. 2, pp. 691–699.
- Bell, D.E. 1975. A utility function for time streams having inter-period dependencies. RR-75-22. International Institute for Applied Systems Analysis, Laxenburg, Austria. (To appear in *Operations Research*, 1977.)
- Draper, N., and H. Smith. 1966. *Applied Regression Analysis*. John Wiley, New York.
- Fishburn, P.C. 1965. Markovian dependence in utility theory with whole product sets. *Operations Research*, Vol. 13, pp. 238–257.
- Holling, C.S., et al. 1974. A case study of ecosystem management. In Project Status Report: Ecology and Environment Project. SR 74-2-EC. International Institute for Applied Systems Analysis, Laxenburg, Austria.

- Keeney, R.L. 1972. Utility functions for multiattributed consequences. *Management Science*, Vol. 18, pp. 276–287.
- Keeney, R.L., and H. Raiffa. 1976. *Decisions with Multiple Objectives*. John Wiley, New York.
- Koopmans, T.C. 1960. Stationary ordinal utility and impatience. *Econometrica*, Vol. 28, pp. 297–309.
- Meyer, R.F. 1970. On the relationship among the utility of assets, the utility of consumption and investment strategy in an uncertain but time invariant world. In *OR69: Proceedings of the Fifth International Conference on Operational Research* (J. Lawrence, ed.). Tavistock, London, pp. 627–648.
- Raiffa, H. 1969. *Decision Analysis*. Addison-Wesley, Reading, Massachusetts.
- Winkler, C. 1975. An optimization technique for the budworm forest–pest model. RM-75-11. International Institute for Applied Systems Analysis, Laxenburg, Austria.

DISCUSSION

EDWARDS: I believe you made the statement that you use the simulation model directly to test the reasonableness of the utility function. I suppose that means that you ask the decision maker to evaluate policies directly and then compare the implications with those of the utility function. If the decision maker is in fact capable of giving you the answers to such questions with good reliability, why did you bother to assess the utility function in the first place?

BELL: Of course, we had to test to see if the utility function agreed with the intuition of the ecology group on certain specific outputs. In some cases they gave me two outputs where they were confident that one was better than the other in order to test the function, but usually they were looking to see if the rating of the function was sensible.

Even if they had been perfectly able to judge their preference for one time stream over another, there is still the problem of the manpower needed to compare the thousands of time streams generated by the simulation model and to take into account the uncertain outcome associated with any given policy.

This coupling of a utility function with a simulation model seems to me to be an important use of utility functions.

MEYER: There is a robustness assumption here, and that robustness assumption is that by using a utility function that is in some sense near to the “correct” utility function, you will be led to near optimal policies.

MacCRIMMON: Now what would happen if you presented forestry experts with those policies evaluated as nearly optimal for the ecologist, and they said that they all seemed terrible?

BELL: One of the reasons they would say that is that Bill Clark and ecologists in general are operating with a much longer time horizon. In fact, the forestry experts who came to IIASA were interested in this year, and maybe next year, whereas the ecologists are running 200-year simulations.

MacCRIMMON: What would you have to do in that case? Presumably, the 18 months you spent with the decision maker was a learning experience. How much time did you have to spend with the foresters to get their inputs?

BELL: One purpose of this study was to see if the resulting policies are sensitive to the objective function. If the answer is yes, the policy is completely different depending on the objective, and you'd have to think hard about whether to spend a lot of time to get a better representation of the preferences of these forestry experts.

TVERSKY: Perhaps there is some imbalance in terms of division of effort: construction of the utility function in the first place and the somewhat crude way of evaluating the output of the simulation model in the second.

BELL: You have to make the decision on some basis. All I am doing is calculating the expected utility of each alternative using the outputs of the simulation model. I am, in effect, saying that this utility function suggests this policy. And then I have suggested scrutinizing the results. How would you suggest choosing a policy from a simulation model?

TVERSKY: It's rather natural to go through several iterations. Do a rough utility analysis; identify some policies that you seem to like very much. After these results, go back and refine the simulation and the utility and iterate again.

EDWARDS: It's very disquieting to me that you have gone to so much trouble to elicit a very sophisticated utility function, and then attempted to validate it by plain old preference judgments. Psychologists can give you 10,000 reasons why such judgments are lousy.

BELL: Eighteen months ago if you had asked me what I would do, I would have said, "Do such and such regression and get the utility function." This process has changed my answer. What I am saying now is, "Let's feed the utility function into the computer and look at the output."

KEENEY: Suppose you evaluated policies *A* and *B* with the utility function and found *A* was preferred to *B*. Then suppose Bill Clark observed just the simulation output of both policies and preferred *B* to *A*. Finally, suppose he carefully examined the reasons why *A* was preferred to *B* with the utility function. Which policy do you think he would then prefer?

BELL: We haven't done that yet, so I don't know. However, after I had the utility function for the employment stream, I printed out ten period streams with their utilities. Then I showed Clark two time streams. His initial reaction was to doubt the ordering. When he examined it in detail, he did agree with the ordering implied by the utility function.

EDWARDS: I've done some experimentation of this sort. I have found that if you work with the person long enough, then he understands what he is doing and comes to adopt the formulation. He will take the implications of the utility function as a criterion against which to validate any preference rankings. Related to this is something that Dr. Bell implied that is very important and worth saying explicitly. The organism that comes out of this prolonged process, which is in part training and in part analysis, is not the same organism that went in. An enormous amount of learning about how to conceptualize values and about aspects of one's own value judgments has taken place in the course of your interaction with that

character (the decision maker). You are not going to be able to take preferences before and after and compare them and get anything that looks worthwhile, because you are not dealing with the same organism. Moreover, you can't expect one's preference to be unaffected by all the learning that has been going on about preferences. Such considerations come under the general heading of validation of the utility function, a topic that I consider to be perhaps the central topic in utility theory and certainly the most unmanageable.

BALINSKI: It seems to me that this very elaborate analysis specifying what the utility function was is, in fact, terribly crude. A lot of assumptions are made. Therefore, the whole activity of coming back afterward and studying the implications seems to me in a certain sense studying the implications of the list of preference assumptions. The purpose of this postoptimization analysis is to try to show the decision maker what the implications of his assumptions are.

Another issue that bothered me throughout the discussion is that you seem to have simply accepted the simulation as being the real world. Why do we accept this at all? Has much work gone on to examine the extent to which the simulation does represent the real world? And to what extent has this influenced the decision makers to say, "Yes, I accept this thing because . . .?"

BELL: I understand that the Canadian government has extensive data for the last 30 years and that they can spot the outbreaks for the last 200 years, and the simulation model validates well against that.

MEYER: I would like to comment on what Dr. Balinski said. I think there is a complete symmetry between the simulation model, on the one hand, and the preference function, on the other. The simulation model is not the real world. The structure of the simulation model — specifically, the variables and equations — is the principal decision one makes when developing the simulation model. The parameter estimation is, to my mind, secondary. Simulation models just do not correspond to reality at all. But as a whole, such models are reasonably robust to small errors in parameters. I think there is complete symmetry on the utility side. There is the general structure of the utility function, composed of additive and multiplicative parts, involving independence and dependence, and so on: structuring that is what Dr. Bell spent a lot of time on. Only recently have people decided to spend a lot of time on specification of the structure of the utility function. This corresponds completely to specification of the structure for simulation models. There is the parameter estimation in Dr. Bell's utility function, which is subject to all kinds of problems such as certainty effects, and so on (see Tversky, Chapter 9). Again we hope there is a certain robustness. What I welcome in all of this is that the same kind of attention is now being given to the utility function that is used as a surrogate for the decision maker as is given to the simulation model that is used as a surrogate for the real world. The surrogate should not be confused with the real thing on either side of the picture.

BALINSKI: But how do you validate the structural aspects of the utility function? In some sense, those of you who work with axioms understand their

implications. When you come to a decision maker who presumably does not have the same sort of abstract sophistication, it seems to me that he accepts a certain structural property without really knowing what the implications are. Maybe when he sees the implications he might say, "I don't like that at all; it's not right." I am supporting the statement that you have to go back and look at all the effects of these assumptions. This seems to me terribly important. I am very uneasy about the construction of these utility functions without confirmation of their implications.

MEYER: Not all these things are subject to validation, just as with the simulation model. In a model of the economy, you might not believe that the level of trade is influenced by the level of steel production even though it shows a correlation if you do a regression. If your structural equations do not directly tie these variables to each other because you don't believe there is a mechanism tying them together, then that's just a belief that you have about the mechanisms that work in the real world. It is not subject to validation because you can't really put experiments on it.

The same thing is true with some of these independence and conditional independence relationships that are elicited from the decision maker. They seem reasonable after a while, and to my mind it is important to devise a technology to determine what seem to be reasonable simplifications. Afterwards, you should go back and validate in two ways. You should validate that the simulation model does more or less correspond to the real world in terms of consequences, and you should validate that the decision maker's preference on the proposed policies seems to correspond with what the model proposes.

RAIFFA: Perhaps I could say parenthetically that there is a history of internal debate in IIASA between the ecologists and the economists on the role of discounting; the ecologists were very uncomfortable about the required intertemporal preference conditions. When Dr. Bell was checking these conditions, you could see that the ecologists really would not accept the additive discounted form on some of the ecological aspects. Because of their strong feelings, the ecologists were ready to reject this whole kind of formal analysis. I think this is an example of how probing indicated that some temporal aspects could be treated in a way different from discounting. But there were still some generalized independence assumptions.

BELL: You have to remember that I did emphasize that this was almost a private experiment between me and the ecology group. It was not proposed in the IIASA research proposal 3 years in advance. The entire process was designed — I use that word loosely — and carried out step by step. Its main purpose was as an experiment to see if the ecologists think that this type of analysis is useful.

Part Three

General Discussion

19 General Discussion

Throughout the conference there were lengthy periods when a formal agenda was set aside and the discussion allowed to find its own way around the possible topics. So many thought-provoking ideas emerged that it was easy to miss a dozen of them while developing a single one in one's mind. A complete transcript of these discussions would occupy more space than is available, so we have chosen to extract five topics that had some cohesion. What appears here is a heavily edited version. It is hoped that these discussions will provide a starting point for independent discussion among readers.

CHECKING OF INDEPENDENCE ASSUMPTIONS

Much of the usefulness of the multiattribute utility approach to preference analysis relies on assumptions of independence between the attributes. Concern was voiced about how often these assumptions are tested for, regardless of whether they hold. The feeling was that if the analyst is experienced in the theory of these assumptions, his intuition will be as good a guide as questioning the decision maker; indeed, the analyst may influence the results of questioning by the nature of the questions he asks.

WEGENER: I would like to make a comment on the question of whether the independence checks have to be performed between attributes. There was a conference on multiattribute utility and probability in Darmstadt recently, and there was a review paper presented on applications of multiattribute utility. I think there were about 90 references to recent applications. If you look through them, you will find that almost none of these applications, which were real-world applications, really went through all the checking procedure. Now are all these people ignorant? I don't know. The fact is that the majority are quite satisfied with what

comes out of these procedures, and they work well. What is your conjecture about the possible convergence of the theorist's requirement and the requirements of practical applicability?

RAIFFA: I have the feeling that if you look at most applications of probability theory as well, you'll find that people overwhelmingly assume that random variables are independent, and sometimes they go very, very wrong because of this assumption. It is not very difficult to have people reflect upon whether the variables should be independent, and since they are sometimes dependent, simple transformations would make you change the nature of the variables so that they would be independent. I think the same thing goes on here. I think that it is not very difficult to check the quality of independence assumptions.

WEGENER: In fact, it is not done in the majority of cases.

RAIFFA: That's right, and independence of random variables is not checked in the majority of cases either, and we all know that experience has shown that many times you can go vastly wrong. I think I can give many examples in the probabilistic domain where, if you ignored dependencies, you would get into terrible, terrible trouble.

EDWARDS: I agree very strongly with what Dr. Wegener said, but I think that what happens very often is that an informal check of some of the assumptions takes place when the dimensions of value that you are going to consider originate. You have informal ideas about what makes sense and what does not, with respect to the kind of independence that may be needed for that particular aggregation procedure. You think of this as you are generating dimensions, but you don't usually go through the vector checks referred to here. Moreover, I am not at all sure whether you will ever be able to do much about this under the typical time constraints of this kind of work. Access to the decision-making body that you are attempting to advise is limited, and it is difficult enough to show them why they should be interested in a particular aggregation rule at all and why they should be willing to give numerical values to things that are for them inherently non-numerical. Trying to explain some of the further subtleties of the problem is just about guaranteed to turn them off. I think the only solution to this problem is the informal one, and I think the informal one is frequently used.

MEYER: There are many situations in which I am quite willing to take upon myself the responsibility that I believe these things to be utility independent if you asked the right questions. You just need a certain amount of experience. And therefore I really see this line of research as leading in due time to a higher degree of sophistication and qualification among the people working in the field, leading to better general structuring of the utility function that is used, and not necessarily leading to an enormous apparatus of question asking that would cause any real city government to throw you out of the office. I think it is quite wrong to think in those terms.

DYER: I think often a decision maker does not want to make a decision; he would rather have some black box make the decision. Saying that the decision

maker accepted something is not really, in my mind at least, enough to warrant concluding that it was a good study. I think it's up to the people who do studies of this sort to be aware of the kinds of mistakes they might make and to understand the theory that has been generated in the last 10 or 15 years, and the implications of it, and consequently, to do responsible analyses.

ISSUES BEHIND MAKING TRADE-OFFS OVER TIME

The problem of quantifying future preferences over future events is perhaps the most difficult area in which to draw up a list of convincing axioms for preference relationships. The uncertainties associated with the overall impact on one's life of choosing a career, for example, are overwhelming. On a larger scale, technological developments produced in the seventies could profoundly affect the lives of future generations, but we are unable to judge which of these might be beneficial and which harmful. We are also unable to judge how we should divide the "resources pot" between ourselves and these future generations. The following exchange offers but a flavor of the long discussion that took place on the subject.

MEYER: Decisions taken in the public domain are ultimately political compromises that are worked out between several parties — individuals who represent interest groups or different points of view. Ultimately, the role of analyses in that process is to help persuade, to somehow pre-empt some arguments from the decision, perhaps to convince the person for whom they are commissioned of the rightness or wrongness of what he is going after. I see them in any political system that I know of, except for a pure dictatorship, as helping the protagonists in a bargaining or a negotiation or adversary proceeding. Simple discounting has a lot to recommend it because it is so transparent and everybody sees what you are doing. You can debate on the discount rate to be used, you can have probing discussions about what's behind the numbers that are being discounted. You don't get lost in the difficult structure — the typical politician has a hard enough time understanding the simple discounting, and he is not going to understand any of these utility functions.

RAIFFA: Since I have gone back to the United States, I have been asked to sit on some committees dealing with trade-offs in environmental, ecological, and economic problems. There is a vehement attitude among the noneconomists toward the role of discounting; they feel we are selling future generations short because of discounting. If you talk about a 10% discount, you are really ignoring the long-run future, and I think at least the ecologically oriented community that I am dealing with is grasping for some sort of rationale that they can use to make intergenerational trade-offs.

MEYER: I find intergenerational trade-offs especially hard. They must always be viewed in the light of population expansion. It's not merely the quality of air

we breathe but the number of people that are there to breathe it. I find these problems just right to be approached by this method within a research framework, but I don't think that the methods themselves can enter the political process at this point, and I doubt if they ever can. I think you must find other ways of popularizing the conclusions you draw as a sophisticated analyst.

TVERSKY: A lot of effort is put into the choice of a profession or a career, and there are various institutions concerned primarily with giving advice and doing research that ought to advise young people about what they should do. There is a great deal of uncertainty, and in some respects it is probably one of the most important conscious decisions people make in their lives. Do you think this is a promising opportunity for application? I'd like to see somebody formulate a set of recommended axioms that identified which independence conditions people could live with and which not.

MEYER: I started to produce some computer programs using multiplicative utilities to assess lifetime utility functions. For example, one MBA student who was an officer in one of the armed forces was trying to decide whether he should just simply leave the armed forces and take a job in private industry or government or whether he should stay in the service for the 12 more years that he would need in order to get his retirement pension — a career choice. He was trying to figure out which would really be better, given his opportunities and given all the uncertainties in the environment. Other such decisions are life insurance decisions. How much life insurance should you carry? Everybody feels very vague about that question. I changed my idea of how much life insurance I should carry when I put myself through my programs, one of the early guinea pigs.

KEENEY: Did you actually change the amount you carried?

MEYER: Yes, but I really would not want to state that was a triumph for the model since I am obviously a biased user.

AUTOMATED PUBLIC DECISION MAKING

A special topic emerged from general discussion that focused on Ward Edward's talk. Could some automated decision process help to relieve committees of the load of reviewing routine cases individually? This would enable petitioners not only to have a quick decision but also to design their petitions with full knowledge of the criteria by which they would be judged. One speaker foresaw election campaigns in which the candidates could describe their policies in terms of parameters.

TVERSKY: The issue is the following: you basically propose to offer the public some information regarding decisions. The question is whether, by making this information publicly available to interested parties, you allow them to use this information to cheat or bypass the system. Not revealing this information could be in the public interest.

EDWARDS: I disagree with that. I think that in almost every situation where public decisions are being made, it is better if the basis for decision is well known.

MEYER: It seems to me that you are talking about the automation or semi-automation of a decision-making activity according to a kind of discriminate function, a value function that you established, that more or less simulates the way decision makers operate. Now, getting good decision rules that will simulate what those people do is one task, and getting them to make their decisions better is another task. Presumably, you are attempting to improve decision making by focusing the attention of the panel on a limited number of cases, say those that are of a common type, rather than wasting your time on all of them, and then deriving an evaluation for the rest. The strategic question for the particular panel or committee to decide is whether they want to use such criteria. What should the criteria be if they want to use them? Do they want to publicize their use or not? What impact does this have on the nature of decision making? That's the strategic issue: to provide a tactical instrument that they may or may not want to use.

WEGENER: I feel that this procedure is a step in the direction of replacing individual decisions or judgments by routine judgments simply by decomposing them into large decisions, minor decisions, or minor judgments, and I think this can be done in many fields. It can have one effect that might be very helpful: it could relieve the burden of administration and make people free to concentrate on more important decisions. For example, public discussion could concentrate on the periodic updating of the standards that go into the procedure, which certainly will not be the same 10 years later, and the public could participate in the kind of thorough debate that now is held only when individual proposals are at issue.

EDWARDS: I so much agree that I would like to read a passage from my paper: "Only if political and social circumstances or technology changed would reconsideration of the agreed-on measurement methods and importance weights be necessary, and even such reconsiderations would be likely to be partial rather than complete. They would, of course, occur; times do change, public tastes and values change, and technologies change. Those seeking appropriate elective offices could campaign for such changes – an election platform consisting in part of a list of numerical importance weights would be a refreshing novelty!"

LUCE: I should think that the university would be the first place that one might attempt to employ these methods, partly because in the university no one will be too shocked by professors performing the analysis, and other professors will probably be involved in some of the decision making and presumably will understand the kind of arguments that are being used. And then, of course, they are the ones that pay the price for any failures of the system.

MEYER: Just think about this method being used for promotion of faculty! Why do we set up committees to look very carefully at promotion to tenure? Why do we have panels for admission of students? Why do we have this committee of yours? It is to force a particular set of people to be confronted day after day with individual situations so that they are somehow intimate with them, so that they

perceive whatever changes are going on in their environment and so that discussion of these changes takes place as soon as they are perceived. But if, by some mechanism like the one proposed here, the committee discusses only every tenth instance that comes up because nine out of ten are more or less routine, then it can be argued that they are really less expert and less aware of whatever is going on in this domain. An argument can be made against the automation of anything or any kind of decision support, and I certainly would not want to say that you must not do this, but I think the important issue is this: When and to what extent do you, in repetitive decision making of this sort where a group of individuals is confronted with successive cases, do this? Do you want to do it in the justice system? After all, it's one case after another, and they are much the same; yet we take enormous amounts of time to create a process of examination and trial that sets the tone of a society. Process is vitally important, and before you start playing with it by automating, I would suggest deep discussion about the true effects of changes in that process.

TVERSKY: I'd like to attempt a partial response. To begin with, I am very sympathetic with Dr. Luce's suggestion that we should experiment first on a small scale, but I really think that the major determining issue — to decide whether to automate certain decision procedures — depends on what the alternative is. I think the drawbacks should be spelled out. People react very differently when they are being rejected by a committee of people and when they are being rejected by some kind of mechanized, automated decision. This cost we may or may not be willing to pay. But there is a cost, and I think the cost increases when you meet something like promotion. The costs, of course, are not constant. It's part of an educational process, and maybe if we get used to it after several years the costs will be reduced; people will get used to it because the process is more efficient.

ZIONTS: I think there are easier problems and there are more difficult problems, and I guess I can't help but feel that coastal land use is one of the more difficult problems. A problem that strikes me as an easy one is one on which U.S. banks, at least, have done a fair amount of work — applications for relatively small loans. There is a form and you are asked to fill it out. If you are married, you score two points; if you have one or two children, you score one point; if you have more than three children, you score zero points, and so on. They then add this up, and if your score comes to a certain number, they give you a loan. This may seem sensible or not, I suppose, but to me at least this kind of decision is relatively simpler than the decision on coastal land use. We must learn more about these more routine types of decision before we automate those that are more difficult.

BELL: Any process, any decision-making body, can be replaced by a machine if you allow an appeal. If the two of us have a problem, we go to the machine; the machine says yes or no, and then either one of us is given the right to appeal to the body that we would have gone to anyway. The greatest number of cases that the decision body is going to have to consider is the number they usually have to consider. This brings you to the point of how accurate the yes—no machine

is. If it is no better than the toss of a coin, we may tend to appeal anything that would have gone before the court anyway, and, at the other extreme, if it is very accurate and if it is known to replicate the board's decision in every instance that goes to an appeal, the decision body will have many fewer routine matters to consider. I am assuming the board does not back up the machine out of self-interest.

BALINSKI: Even if we use the random number generator, I suspect the governing body or the decision board would still have less work than it has right now.

RIVETT: Maybe the boards are doing that right now.

MEYER: If we did have a random number generator to make decisions, I would try all sorts of developments that I knew would never pass the board but might just pass the machine.

BELL: If no one appeals, then you are justified. If you are parking on the high street day after day after day and nobody appeals, then there is nothing wrong with doing it.

MEYER: What do you mean, nobody appeals?

BELL: If no one appeals to the police courts about your parking on the high street, then nobody cares.

MEYER: If we are dealing with condominiums, they are already standing there, so it is too late to appeal.

EDWARDS: No, we are talking about *proposed* condominiums.

BELL: Yes, exactly. I go up and say I wish to build a condominium; the machine says yes, and then a notice is published in the gazette or something.

MEYER: And that's when the process starts.

UTILITY AS A DESCRIPTIVE VERSUS A PRESCRIPTIVE THEORY

From the discussion that took place, it is clear that decision analysis is still at the stage of providing insight into the decision-making procedure rather than offering hard recommendations. Some see it ultimately as an automatic means of making decisions in the absence of the decision maker. If and when this comes about, should the automatic procedure be descriptive or prescriptive, that is, should it replicate the decision making of human beings, including human failings, or should it choose that decision that is rationally and mathematically the best? Some of the papers presented at this conference seem to give strong evidence that decision analysis is not as ineffective as the tone of the following discussion would suggest.

ZALAI: I feel that it is urgent to have a discussion on the relevance of the utility concept as prescriptive or normative versus descriptive. This came up partly in connection with Tversky's paper (Chapter 9), in which he shows that, regardless of the utility concept and its axioms, when we try to describe the behavior of the decision maker or the people, we find it is not consistent with the theory. It is a

benevolent description theory, which I admit is good for normative purposes to teach people to try to make rational decisions, to explore the utilities or the good and bad effects of different decisions.

RAIFFA: For a long time I tried to collect examples of descriptive behavior, of behavior that would be inconsistent with the utility axioms or with rationality axioms of the Savage kind. Some people, who did not understand my motivation, were surprised that I, an advocate of decision analysis, would go around collecting such examples. My reaction was simple: if descriptive behavior always mirrored the prescriptive axiomatic structure, there would be no point in building up a prescriptive theory. It is just those places where people's behavior differs markedly from the rationality axioms that you would like to highlight. Where there is a great deal of inconsistency, you should ask whether, on deeper reflection, the individuals want to behave that way. If they do want to behave that way and they can give reasonable rationalizations, then, as analysts, we should extend the theory to accommodate this. Now I know myself that when I make decisions I am very often inconsistent and it is not worth my while to worry about whether I am consistent; but if it is an important problem and somebody shows me an inconsistency, then I would want to think more about it. Sometimes I will change my mind, and sometimes I won't. A good many people think of utility theory as a guide for prescriptive behavior rather than as a rationalization of descriptive behavior.

RIVETT: I'd like to make a similar suggestion on this topic. I am constantly worried about the use of utility theory since it has been going on a long time now and nobody actually seems to take any decisions based on it. We might deduce from this that people aren't very logical and should improve themselves. I discovered some examples in the United Kingdom where the analysts say, yes, the decision was taken using utility theory, but when you talk to the manager, he says that he has never heard of it. I'd like to bring together the normative and the descriptive theories.

RAIFFA: I know of several examples where people have used utility to guide actions, but, admittedly, the number of such examples is limited. The theory has been around for a long, long time, and it is not used very much. I think univariate utility theory is more of a theoretical concept than an operational one. I suspect that multivariate utility theory will become much more operational because there is much more need for analytical help.

RIVETT: I certainly don't use utility theory in many of my own personal decisions. I'd like to find a situation where a manager, having got his utility function, is happy to delegate his decision making to other people.

TVERSKY: The issue is whether decision analysis is a good procedure for helping managers, and in that sense it is good only if it is compared with other alternatives. With regard to the normative domain even in the certainty situation, it may still perform much better than unaided intuition. The point I was trying to make was that utility theory is inadequate because it is too weak. To form a really powerful normative analysis, you want some more principles that would further restrict the utility function.

THE STRENGTH OF APPLICATIONS

A lengthy discussion took place on the last day of the workshop about decision analysis in practice. Great emphasis was placed by all speakers on facing the realities of the decision maker—analyst relationship. The analyst must build a bond of trust between himself and his client and, in particular, must satisfy his client that the analysis is helping to solve the problem.

Several speakers questioned the philosophy on which decision analysis is based, if seen from a practical viewpoint, pointing out that a decision maker often takes actions rather than makes decisions, that often no decision maker exists, and that expected utility is an inappropriate context in which to make evaluations.

Those participants who had worked closely with decision makers were more enthusiastic about the applicability of decision analysis, recognizing, however, that at its present stage of development it is probably more useful as a means of providing insight than analytical answers.

RAIFFA: Let us now talk about the problems of implementation and the client relationship.

WIIG: I earn my living from advising clients on one point or another. I probably cost the client a great deal of money, so that the client has to commit considerable resources to use my help. As a result the client is very concerned about having his problem solved, and he is less concerned about allowing me to use my methods to solve his problems. I find that in many instances I do not know what method I will finally use in solving the client's problems; unfortunately, I rarely end up doing decision analysis because the client does not understand the situation that way, and he is unwilling to commit time to think about it in that particular way. This means that I am very often at a disadvantage in trying to assist him in making his decision. As practitioners of decision analysis, we need to have a very large repertoire that we can draw on and thus instill in the client the necessary trust in us. It is trust that is most important.

BALINSKI: I don't quite see why a decision maker, the client, should place any trust in the decision analyst. It seems to me that in the applications I've heard described here, the most striking thing is the crudity of the attempts to discover some utility function. All the applications seem based on the notion that the utility function is there, that it exists, and that it has certain properties. Some of these properties, I thought, were called into question at the beginning of the conference, and yet the practitioners seem not to be worried about whether this is a reasonable model; they merely go out and apply the tools. I feel much more at ease with a paper like that of Sam Zionts (Wallenius and Zionts, Chapter 3), in the following specific sense. There is a model in the background that is very complex; a decision maker cannot encompass this model in his head, so possible solutions are investigated, and the decision maker is given the opportunity of seeing the consequences of what he thinks his preferences are. This approach gives me the feeling of a very much greater source of information. David Bell's paper, too, conveyed this notion

of feeding back and trying to teach the decision maker about what the preferences are, thus providing him the basis on which he would ultimately make his decision.

RIVETT: As far as I can see, there is no one here who actually earns his money taking decisions in anger – working in a company (not advising a company) and rejoicing in its successes and being saddened by its failures. I look back at the decision makers I know and ask what they would have got out of this workshop if they had been here. Would our descriptions of the problems with which they are faced match up with their own views? I've got the feeling they would probably say no.

BELL: With reference to Karl Wiig's point about building up the confidence of the man you are serving, does anyone here, when he has done a decision analysis or an analytical study, then offer his own assessment of the value of the analysis? Does it make any sense to say, "Well, I spent a week, but I don't really think it has been of much value"?

WIIG: To answer briefly, I don't think I've ever delivered an answer that I wouldn't like to own up to in terms of the analysis.

BELL: You always feel, having done the study, that the recommendation you make is a valid one?

WIIG: I don't think I am in the business so much of providing recommendations as of providing insight.

EDWARDS: That's been my experience, too. Moreover, the kind of insight that I feel I have delivered virtually never takes the form of a solution. Rather, it takes the form of a way of structuring the problem, a set of dimensions that are relevant, a way of thinking about what the issues in the aggregation of these dimensions are. This leads me to another point. There are two myths that seem to me to cloud this issue. One myth is that there is such a person as the decision maker. A decision-making organization, yes, but it is very difficult to find a man who will own up to being the decision maker. Frequently, there will be a man who admits, as Harry Truman did, that the buck stops here, but if you explore what he really means, it's usually that it didn't start here. That is to say, by the time something gets to him, it has already been very carefully studied and worked through, and his function is basically to work with what is already a highly developed analysis generated by a lot of other people. Now, if the decision maker is a myth in this sense, then the notion of utility is in some similar sense a myth.

NAIR: I do make decisions using these techniques where my money is involved, and, in addition, I do help clients make decisions. I have found these techniques extremely useful in terms of looking at alternatives and giving "insight." On the basis of personal experience, therefore, I'd say that such techniques are useful. The biggest problem I have found in dealing with clients is problem definition. They won't tell you their full problems in the beginning. The main difficulty that we get ourselves into is trying to solve too much of the problem in a first visit. I found that it was often beneficial to say that we had helped them structure the problem, and that was all. By doing this we were generating the necessary trust that would enable us to continue.

MEYER: Ward says that the existence of decision makers is a myth. I say that decision itself is another of the many myths. In fact, what happens is that people take actions, that they present Truman with a number of alternatives that already have been discussed and rediscussed in the very real political world outside Truman's office. Truman can say that the buck stops here, but the buck doesn't stop there at all, because he has to make a choice about whether he is going to give a deliberate speech on this topic, or hold a press conference, or buttonhole some congressional leaders. And these are the decisions he really has to make. They are action decisions, affecting a process that's going on.

LARICHEV: I think it is very interesting to ask what conditions the analyst works under. The best estimate of the value of his contribution is the practical implementation of the work, because the motivation of the decision maker is very different from that of the analyst. If you knew that your recommendation would be implemented, it would be very difficult to apply mathematical models to decision making.

FISHBURN: We are all aware that over the past two hundred years, a number of different ideas have developed about how people actually go about their affairs and, in addition, about how people ought to do things, and about whether the use of the words "ought" and "should" is even meaningful. But I think that ideas and values and beliefs have been handled in a reasonably good way through the use of the notion of utility, or subjective expected utility.

LUCE: I'd like to make a brief comment on expected utility and the introduction of probability in a highly artificial way in order to force the application into theory. I think when probabilities are a natural part of the problem, when there is uncertainty that is naturally there, this may be sensible. But when we start introducing vague gambling choices between serious alternatives in order to force this theory, many of us get nervous about it. The decision maker, if he understands at all what you are proposing to do, is going to think this is a very, very strange thing you are doing, and wonder why it should bear on his decision making.

RAIFFA: Well, you have to do it with a great deal of experience and finesse. You have to do it with the realization that some of the things that you have to introduce will probably make decision making worse in the short run because of abuses. I somehow have a feeling – perhaps I'm so biased because my conversion took many, many years and involved very painful decisions, and I tried desperately to find some substitute instead – that maximization of expected utility is going to be around for another 50 years, because there isn't anything that comes close.

RIVETT: I think the real test of a method is persuading someone to do something he doesn't like.

RAIFFA: Ralph Keeney and I have a very good example that we both worked on. The client came in with his mind already made up; he wanted our analysis for advocacy purposes. We proposed a different solution, and he changed his mind;

it was very, very painful for him. We had really not intended this outcome when we began.

When I was a classical statistician and probabilist and worked on classes of problems in genetics and physics, I couldn't get excited about notions of subjective probability. However, when I moved over to another class of problems — problems in medicine and in business where the practical issues were not repetitive and where you could not use objective probabilities — I saw and felt the need for extending the theory, for working with subjective probabilities and learning how to use them. When I became involved in situations in my work with Richard Meyer and others where big monetary risks were involved, I struggled for a long time with ideas other than utility, but I finally convinced myself that utility was important for that class of problem.

In the middle sixties I started working with a public policy group at Harvard, and I also spent some time at the Rand Corporation studying their papers and trying to identify critical analytical issues. I was overwhelmed by the amount of effort that was involved in structuring models, in looking at the interactions, and in looking at the probabilistic framework, but when it came to grappling with the real objectives, so little was done with it. In the public domain, you always face the problem of conflicting objectives, which must be looked at very seriously. I think that Koopmans, who spent a year at IIASA, also believes that in economics the subject matter that is underdeveloped is the systematic analysis of objectives that should be pursued in the public policy sphere.

I strongly believe that the multiple objectives problem will be with us for a long time. I also believe that the problem is probably more critical in the socialist countries than in the nonsocialist countries. Many value trade-offs are made in the nonsocialist countries by market mechanisms, even though some of these trade-offs are often done poorly because of imperfections in the market. So many more decisions must be taken in socialist countries in their attempt to be rational and systematic. But I don't see how they are going to be able to do that without balancing trade-offs between economic, mortality, morbidity, ecology, and socio-political considerations. Somebody has to make these decisions and think hard about them. From what I've seen in modeling from the socialist side so far I think my observations are exactly the same as on the nonsocialist side. They do a lot better in structuring and modeling (including probabilistic analysis) than they do in analyzing the problem of conflicting, multiple objectives. This imbalance, of course, exists in nonsocialist countries as well. More, much more, needs to be done everywhere in the subject matter of this workshop.

Participants and Contributors

MICHEL BALINSKI, International Institute for Applied Systems Analysis, Laxenburg, Austria.

VOLKER BAUER, Battelle-Institut e.V., Frankfurt am Main, Federal Republic of Germany.

DAVID E. BELL, University Engineering Department, Control and Management Systems Division, Cambridge University, Cambridge, United Kingdom.

JAMES S. DYER, Management Science Study Center, Graduate School of Management, University of California, Los Angeles, California.

WARD EDWARDS, Social Science Research Institute, University of Southern California, Los Angeles, California.

PETER C. FISHBURN, The Pennsylvania State University, University Park, Pennsylvania.

M. G. GAFT, Institute of Control Sciences, Academy of Sciences of the USSR, Moscow.

ARNOLDO C. HAX, Alfred P. Sloan School of Management, Massachusetts Institute of Technology, Cambridge, Massachusetts.

A. P. IASTREBOV, Institute of Control Sciences, Academy of Sciences of the USSR, Moscow.

K. INOUE, Department of Precision Mechanics, Faculty of Engineering, Kyoto University, Kyoto, Japan.

ERIC JACQUET-LAGREZE, SEMA (METRA International), Montrouge, France.

RALPH L. KEENEY, Woodward-Clyde Consultants, San Francisco, California.

R. KULIKOWSKI, Computation Centre, Polish Academy of Sciences, Warsaw.

A. B. KURZHANSKI, Institute of Mathematics and Mechanics, Ural Research Center, Academy of Sciences of the USSR, Sverdlovsk.

R. DUNCAN LUCE, Department of Psychology and Social Relations, Harvard University, Cambridge, Massachusetts.

KENNETH R. MacCRIMMON, Faculty of Commerce and Business Administration, University of British Columbia, Vancouver, British Columbia.

CHRISTOPH MANDL, Institut für Höhere Studien and Wissenschaftliche Forschung, Vienna.

ANGELO MARZOLLO, International Centre for Mechanical Studies, Udine, Italy.

RICHARD F. MEYER, Graduate School of Business Administration, Harvard University, Boston, Massachusetts.

RALPH F. MILES, Jr., Systems Analysis Section, Jet Propulsion Laboratory, California Institute of Technology, Pasadena, California.

KESHAVAN NAIR, Woodward-Clyde Consultants, San Francisco, California.

H. NAKAYAMA, Department of Applied Mathematics, Faculty of Science, Konan University, Kobe, Japan.

V. M. OZERNOI, Institute of Control Sciences, Academy of Sciences of the USSR, Moscow.

M. PESCHEL, Academy of Sciences of the German Democratic Republic, Berlin.

HOWARD RAIFFA, John F. Kennedy School of Government, Harvard University, Cambridge, Massachusetts.

VIL RAKHMANKULOV, International Institute for Applied Systems Analysis, Laxenburg, Austria.

C. RIEDEL, International Institute for Applied Systems Analysis, Laxenburg, Austria.

B. H. P. RIVETT, Operational Research Department, The University of Sussex, Brighton, United Kingdom.

B. ROY, SEMA (METRA International), Montrouge, France.

Y. SAWARAGI, Department of Applied Mathematics and Physics, Faculty of Engineering, Kyoto University, Kyoto, Japan.

MASANAO TODA, NIAS, Wassenaar, the Netherlands.

AMOS TVERSKY, Faculty of Social Sciences, The Hebrew University of Jerusalem, Jerusalem, Israel.

J. WALLENIUS, Helsinki Research Institute for Business Economics, Helsinki.

MICHAEL WEGENER, Battelle-Institut, Frankfurt am Main, Federal Republic of Germany.

DONALD A. WEHRUNG, Faculty of Commerce and Business Administration, University of British Columbia, Vancouver, British Columbia.

KARL, M. WIIG, Operations Research Division, Arthur D. Little, Inc., Cambridge, Massachusetts.

E. ZALAI, Karl-Marx University of Economics, Budapest, Hungary.

S. ZIONTS, School of Management, State University of New York at Buffalo, Buffalo, New York.

Index

- Additive representation, 150
 - construction of, 163
- Additive utility, 176, 374
- Additive utility function, 194, 403
- Allais paradox, 212
- Alternatives, identification of, 20, 281, 299, 368
- Applications of multidimensional utility analysis, 433
 - child welfare, 265
 - coal mine layouts, 35
 - environmental urban planning, 358
 - forest pest control, 389
 - government research program, 265
 - land use regulation, 256
 - mining, 35, 279
 - power plant siting, 298
 - R & D planning, 204
 - space trajectories, 367
 - switching circuits, 116
 - urban planning, 323, 363
 - water quality, 249, 271
- Applied systems analysis, 1
- Approximation theory, 195
- Archimedean axiom, 55, 152
- Arrow's impossibility theorem, 248, 331
- Aspiration levels, 7
- Atomic Energy Commission, 302
- Automated decision making, 428

- Bargaining problem, 368
- Behavioral decision theory, 6
- Benefit–cost, 8, 269
 - with risk, 9
- Benevolent dictator and conflict, 373
- Bias, 209, 379
 - certainty effect, 210
 - reference effect, 212
- Bidding, 279
- Bilateral independence, 186
- Binary relation, 174
- Biological impacts, 303, 315
- Branch-and-bound algorithm, 85, 88
- Budworm, 389

- California Coastal Commission, 248
- Canadian Forestry Commission, 389, 390
- Capital investment, 277
- Cardinal utility, 5
- Cash flow, 91, 282
- Certainty effect, 210, 220
- Child welfare, application to, 265
- Client–analyst interface, 433
- Clustering, 203
- Coal mine layouts, 35
- Collective choice, 379
- Comparability, 32, 42, 43, 174
- Commodity bundles, 148
- Concatenation, 149, 158
- Concordance, 64
- Conditional expected utility, 159
- Conditional utility interdependence, 404
- Conflict measurement, 339
- Conflicts, 261, 321, 331, 348
 - and benevolent dictator, 373
- Conjoint measurement, 6, 148

- Consequences, 19, 47, 277, 330
 - analysis of, 47
 - time-stream of, 232
- Constrained optimization, 358
- Consumer behavior, 5, 223
- Consumption, 224, 232
- Convergence, 80, 96
- Convexity, 142
- Cost–benefit, 8, 269
 - with risk, 9
- Cost-effectiveness, 8
- Criteria generation, 21, 266, 283, 301, 394

- Darmstadt, 343
- Decision-Aid, 40
- Decision analysis, 9, 209, 277, 298, 389
- Decision making, automated, 428
 - descriptive, 5, 431
 - prescriptive, 6, 431
- Decision rule, 19, 30, 264
- Decision tree, 284
- Decomposable structures, 149, 156
- Dimensional invariance, 161
- Dimensionality reduction, 142, 356
- Discordance, 65
- Discount rate, 225, 427
- Discounting, 3, 225, 295, 427
- Dominance, 63
- Double cancellation, 151
- Double-counting, 333

- Efficient frontier, 7
- Efficient solutions, 121
- ELECTRE I, la méthode, 64, 68
- ELECTRE II, la méthode, 64, 71
- Energy Research and Development Agency, 299
- Envelope property, 100
- Environmental correlation, 255, 333
- Environmental impact, 257, 316, 389

- Feasible alternatives, 20, 45, 195
- Forest pest, 389
- Formal analysis, 1
- Fractional independence, 189
- Fuzzy knowledge, 44
- Fuzzy outranking, 58, 74
- Fuzzy-set, 113

- Game theory, 49
- Goal programming, 7
- Government research program, planning of, 265

- Gradients method, 107
- Group decision, 111, 257, 320, 362
- Group conflict, 339, 355
- Group welfare, 4

- Hiroshima City, 358
- Hypothetical questions, 131, 207, 244, 276

- Importance, 251
- Importance, weights, 252, 264, 273, 332
- Incomparability, 32, 43
- Independence, 151
 - assumptions, 425
 - bilateral, 186
 - fractional, 189
 - indifference, 185
 - preference, 185, 306
 - utility, 180, 232, 290, 306
 - value, 176, 255
 - verification of, 425
- Indifference approach, 127
- Indifference curves, 104, 129, 131, 149, 411
- Indifference independent, 185
- Industrial systems, 97
- Intangibles, qualities, 3
- Integer programming, 83
- Intergenerational trade-offs, 3, 427
- Interpersonal comparison of utilities, 6, 372, 387
- Intertemporal trade-offs, 224, 401, 427
- Intrinsic value, 69
- Intuitive evaluation, 259
- Investment strategies, 223

- Kernels, 67

- Lagrange multipliers, 359
- Lagrangian optimization, 102
- Land use regulation, 256
- Lexicographic trade-offs, 143
- Linear models, 255
- Linear programming, 77, 397
- Linear weighting, 390
- Long-range planning, 91
- Loss of life, 213

- Man–machine methods, 199
- Marginal rate of substitution, 79, 129
- Mariner Project, 367
- Markovian dependence, 403
- Mathematical economics, 5
- Mathematical optimization, 6

- Measures of effectiveness, 283, 301
- Morphological analysis, 20, 36
- Multidimensional scaling, 6
- Multiplicative utility function, 194, 306, 403
- Multiplier method, 358
- Multistep decision making, 25

- n*-person games, 376
- Nonadditive representations, 156
- Nuclear power, 298

- Objectives, identification of, 21, 283, 301, 394
- Optimization, 6
 - constrained, 358
 - goal programming, 7
 - gradients method, 107
 - integer programming, 83
 - Lagrangian, 102, 359
 - linear programming, 77, 397
 - polyoptimization, 98
 - vector, 98
- Outranking, 58

- Pareto frontier, 7, 99
- Pareto preference, 97
- Partial comparability, 42
- Planning, use of multiattribute utilities in, 249
- Planning horizons, 277, 280
- Polynomial measurement, 157
- Polyoptimization, 98
- Preference–indifference relation, 26
- Preference information, classification of, 28
- Preferences
 - assessment of, 24, 209, 266, 305, 397, 402
 - construction of, 55, 104
 - revealed, 199
 - over time, 225, 402
- Preferential independence, 56, 185, 306
- Preferred proportions, 127, 135
- Prescriptive decision making, 6, 431
- Probabilistic information processing, 166
- Probability, assessment of, 286, 313
- Public decisions, 247, 428

- Qualitative measures, 36, 198, 203, 304, 396
- Quality of life, 330

- Recreation, 405
- Reference effect, 212, 220
- Research and development, 197, 204
- Revealed preferences, 199, 276
- Risk, 165, 186, 212, 278
- Risk attitudes, 186, 282
- Risk-aversion function, 195, 237

- Scaling constants, 259, 264, 273, 310, 332, 407
- Scenarios, 49
- Screening process, 299
- Semiorder, 53, 99
- Sensitivity analysis, 317, 418
- Shadow prices, 80
- Simulation, 292, 324, 327, 420
- Siting studies, 298
- Social decision making, 247, 320
- Social welfare, 49, 320, 370
- Social welfare function, 5, 363, 366, 408
- Socioeconomic impact, 304, 315, 396
- Socioeconomic planning, 329
- Solvability, 151
- Stability of solutions and algorithms, 121
- State-dependent utilities, 232
- State descriptors, 233, 393
 - efficient, 233
- Strategically equivalent, 233
- Subjective criteria, 203, 304, 396
- Subjective scale, 303, 396
- Substitution condition, 218, 220
- Sure-thing principle, 218
- Switching circuits, 116
- Systems analysis, 1

- Thermal discharge, 358
- Thresholds, 53
- Time horizon, 111, 324
- Time preference, 232, 401, 427
- Trade-off analysis, 123, 358
 - intergenerational, 3, 427
 - intertemporal, 224, 401, 427
 - lexicographic

- Uncertainty, 4, 232, 278, 324, 342
- Urban planning, 323, 363
- Utility, 159, 172
 - additive, 176, 332, 374, 403
 - cardinal, 5
 - interdependent additive, 179, 403
 - interpersonal comparisons, 6, 372
 - state-dependent, 232
 - time-averaged, 225
- Utility assessment, simplification of, 172
- Utility dependence, 196, 233
- Utility functionals, 226
- Utility functions, 25, 174, 289, 336

- additives, 194, 403
- approximation of, 190
- assessment of, 402, 409
- linear, 92
- multiperiod, 232
- multiplicative, 194, 306, 403
- S-shaped, 216, 220
- weighted linear average, 250, 253
- Utility independence, 180, 232, 290
 - conditional, 404
 - generalized, 181
 - verification of, 185
- Utility theory, 49
- Value functions, 44, 397
 - assessment of, 397
- Value independence, 176, 255
- Value of life, 215
- Vector optimization, 98
- Water quality, 249, 271
- Weights, 334, 363

(contents continued)

- 6 Conjoint Measurement: A Brief Survey
R. Duncan Luce
- 7 Multiattribute Utilities in Expected Utility Theory
Peter C. Fishburn
- 8 A Practical Methodology of Solving Multi-criterion Problems with Subjective Criteria
O.I. Larichev
- 9 On the Elicitation of Preferences: Descriptive and Prescriptive Considerations
A. Tversky
- 10 A Dynamic Consumption Model and Optimization of Utility Functionals
R. Kulikowski
- 11 State-Dependent Time Preference
Richard F. Meyer

PART TWO: APPLICATIONS

- 12 Use of Multiattribute Utility Measurement for Social Decision Making
Ward Edwards
- 13 The Use of Decision Analysis in Capital Investment Problems
Arnoldo C. Hax and Kari M. Wiig
- 14 Selecting Nuclear Power Plant Sites in the Pacific Northwest Using Decision Analysis
Ralph L. Keeney and Keshavan Nair
- 15 A Community Information Feedback System with Multiattribute Utilities
Volker Bauer and Michael Wegener
- 16 Multiobjective Decision Making with Applications to Environmental and Urban Design
Y. Sawaragi, K. Inoue, and H. Nakayama
- 17 Alternative Formulations for a Trajectory Selection Problem: The Mariner Jupiter/Saturn 1977 Project
James S. Dyer and Ralph F. Miles, Jr.
- 18 A Decision Analysis of Objectives for a Forest Pest Problem
David E. Bell

PART THREE: GENERAL DISCUSSION

- 19 General Discussion
- Participants and Contributors
Index

**THE WILEY IIASA INTERNATIONAL SERIES ON APPLIED SYSTEMS
ANALYSIS**

Conflicting Objectives in Decisions

Edited by David E. Bell, University of Cambridge; Ralph L. Keeney, Woodward-Clyde Consultants, San Francisco; and Howard Raiffa, Harvard University.

Material Accountability

Rudolf Avenhaus, Nuclear Research Center Karlsruhe and University of Mannheim.

Forthcoming

Organization for Program Management

C. Davies (UK), A. Demb (USA), R. Espejo (Bolivia), R. Ostrowski (Poland).

Organization for Forecasting and Planning

Edited by W. Dill (USA).

Adaptive Impact Assessment of Ecological Policies

C.S. Holling et al. (Canada).

The Electronic Oracle: Computer Models and Social Decisions

D.H. Meadows and J.M. Robinson (USA).

Computer-Aided Design

Edited by J. Hatvany (Hungary) and M. Sabin (UK).

**Recent Developments in Real-Time Forecasting/Control of Water Resources
Systems**

Edited by A. Szöllösi-Nagy (Hungary) and E.F. Wood (Canada).

North Sea Petroleum Development: The Development-Environment Interface

D.W. Fischer (USA), D.v. Winterfeldt (USA), J. Owsinski (Poland), S. Ikeda (Japan), and R. Tuch (USA).

Computerized Urban Traffic Guidance and Control Systems

Edited by H. Strobel (GDR).

JOHN WILEY & SONS

*Chichester · New York · Brisbane · Toronto
A Wiley-Interscience Publication*

ISBN 0 471 99506 1