

CONSOLIDATION OF SOILS

UNDER CYCLIC LOADING

CONSOLIDATION OF SOILS UNDER CYCLIC LOADING

BY

MOHAMED MEDHAT M. ELGOHARY, B.Sc. (Eng.)

A Thesis

Submitted to the School of Graduate Studies

in Partial Fulfilment of the Requirements

for the Degree

Master of Engineering

McMaster University

March 1973

MASTER OF ENGINEERING (1973)

(CIVIL ENGINEERING)

McMASTER UNIVERSITY

HAMILTON, ONTARIO

CANADA.

TITLE : CONSOLIDATION OF SOILS UNDER CYCLIC LOADING

AUTHOR : Mohamed Medhat M. Elgohary, B.Sc. (Cairo).

SUPERVISOR : Professor Nyal E. Wilson

NUMBER OF PAGES : vi, 68

SCOPE AND CONTENTS :

A theoretical solution for the progress of consolidation of a saturated soil layer subjected to cyclic loading is obtained. A comparison between the theoretical solution and the experimental results of Kaolin samples consolidating under cyclic loadings is presented.

ACKNOWLEDGEMENTS

The author wishes to express his sincere gratitude to Professor Nyal E. Wilson for his assistance and encouragement throughout the research program.

The financial support by the Civil Engineering Department, McMaster University and the Defence Research Board, is gratefully acknowledged.

The author would like to thank Dr. J.J. Emery for his valuable discussion and comments.

The assistance of Mr. W. Sherriff with the experimental apparatus is very much appreciated.

Special thanks are due to Nadia Elgohary, wife of the author, for her patience and encouragement throughout the research program.

CONTENTS

	Page
TITLE PAGE	i
SCOPE AND CONTENTS	ii
ACKNOWLEDGEMENTS	iii
CONTENTS.....	iv
LIST OF FIGURES	v
CHAPTER I INTRODUCTION	1
CHAPTER II LITERATURE REVIEW	5
CHAPTER III THEORETICAL SOLUTION	9
CHAPTER IV DISCUSSION OF THE THEORETICAL SOLUTION	24
CHAPTER V EXPERIMENTAL APPARATUS AND PROCEDURE	37
CHAPTER VI EXPERIMENTAL RESULTS	43
CHAPTER VII CONCLUSIONS AND RECOMMENDATIONS	60
REFERENCES	63
APPENDIX A SYMBOLS	66

LIST OF FIGURES

Figure		Page
1	SECTION THROUGH A SOIL STRATUM	11
2	FLOW THROUGH AN ELEMENT OF SOIL	11
3	CONSOLIDATION RATIO AS A FUNCTION OF DEPTH AND ELAPSED TIME	28
4	CONSOLIDATION RATIO AS A FUNCTION OF DEPTH AND ELAPSED TIME	29
5	CONSOLIDATION RATIO AS A FUNCTION OF DEPTH AND ELAPSED TIME	30
6	CONSOLIDATION RATIO AS A FUNCTION OF DEPTH AND ELAPSED TIME	31
7	RELATION BETWEEN THE EQUILIBRIUM CONSOLIDATION RATIO AND THE CYCLE RATIO	32
8	CONSOLIDATION RATIO AS A FUNCTION OF DEPTH AND ELAPSED TIME	33
9	CONSOLIDATION RATIO VERSUS TIME FOR CYCLIC AND SUSTAINED LOADINGS	35
10	AVERAGE CONSOLIDATION RATIO VERSUS TIME FOR CYCLIC AND SUSTAINED LOADINGS	36
11	THE CONSOLIDOMETER	38
12	TRANSDUCER HOUSING	40
13	TYPICAL CURVES OF LOAD, EXCESS PORE PRESSURE, SETTLEMENT READINGS VERSUS TIME	51
14	EXCESS PORE WATER PRESSURE VERSUS TIME	52
15	EXCESS PORE WATER PRESSURE VERSUS TIME	53

Figure		Page
16	SETTLEMENT READINGS VERSUS TIME	54
17	SETTLEMENT READINGS VERSUS TIME	55
18	CONSOLIDATION RATIO AS A FUNCTION OF DEPTH AND ELAPSED TIME	56
19	CONSOLIDATION RATIO AS A FUNCTION OF DEPTH AND ELAPSED TIME	57
20	EQUILIBRIUM CONSOLIDATION RATIO VERSUS CYCLE RATIO	58
21	COMPARISON BETWEEN CYCLIC AND SUSTAINED LOADINGS.....	59

CHAPTER I

INTRODUCTION

When a sustained pressure is applied to a saturated soil, the entire pressure is carried initially by the water in the pores of the soil as excess pore water pressure. If drainage is allowed, the gradient of the excess pore water pressure causes flow of water out of the soil, and consequently dissipation of a part of the excess pore water pressure. The process of dissipation of the excess pore water pressure, and the gradual squeezing of water from the soil, is called "Consolidation".

As consolidation proceeds, the excess pore water pressure dissipates, and the pressure is transferred gradually to the soil particles. Finally, after the dissipation of all the excess pore water pressure, the entire pressure is carried by the soil particles. Consolidation is associated with volume change, drainage of water and increase in the soil strength.

Terzaghi (1925) developed the theory of the one dimensional consolidation of soils. The mathematical solution of the theory provides a procedure to enable engineers to predict pressures and settlements in a stratum of a consolidating soil at any time. This theory, although adequate for sustained loading, does not consider cases of cyclic loading.

The progressive settlements of structures on compressible soils, such as clay and peat, raise problems of practical importance in engineering practice. Highway engineers have had many problems as a result of cyclic loadings caused by the passage of vehicles along a road. A soil layer under traffic loading is subjected to a large number of load applications separated by intervals under the overburden pressure only. For highways, the duration of load application while the traffic is in motion is very short, usually a fraction of a second. However, at road intersections the duration of load application may reach several minutes, and in parking areas the duration of load application can be several hours.

The discrepancies between the values of settlements obtained from theoretical predictions based on the theory of consolidation under static loads and the values of settlements obtained from field measurements, have indicated the need for investigations and studies on the problem of consolidation under cyclic loadings.

Cyclic loadings have other practical applications such as : water level variations due to tide, wave action against waterfront structures, moving loads across a factory floor or over a support of a bridge and wind action on a structure causing pressure variation in the supporting soil. The process of consolidation and the shear strength characteristics of soils are interrelated

topics and knowledge of them is essential to the understanding of the soil behaviour.

The purpose of this research work is to investigate the progress of consolidation of a soil layer subjected to cyclic loading. As a starting point for such a study, the case of one dimensional consolidation has been taken, as it involves the essential physics of the consolidation process but requires the simplest mathematical and experimental treatment.

A theoretical solution for the progress of consolidation of a soil layer subjected to cyclic loading is obtained. This solution provides a set of curves describing the process of consolidation of the layer. The influence of the different parameters affecting the process of consolidation such as the coefficient of consolidation of the soil, the thickness of the layer and the cyclic load characteristics is investigated.

In order to compare the theoretical solution with experimental results, a series of tests was conducted. In these tests, the samples were subjected to cyclic loadings of different duration, frequency and magnitude in a specially modified consolidometer. The consolidometer was provided with pressure transducers placed at different levels for pore pressure measurements along the samples. The settlements of the samples were measured using a dial gauge. The cyclic loadings were

applied hydraulically.

The samples used in the tests were prepared from commercial kaolin known as Hydrite U.F, which is a uniform graded mixture of silt and clay. The kaolin powder was mixed with distilled de-aired water to form a slurry in the consolidometer. The reason for choosing kaolin was to obtain homogeneous saturated samples.

CHAPTER II

LITERATURE REVIEW

Terzaghi (1925) developed the classical concepts of consolidation. It was assumed that there exists a maximum effective pressure that can be supported by the soil particles for every void ratio of the soil. When an applied pressure exceeds the supporting capacity of the soil particles at a certain void ratio, the excess pressure is carried by the water in the voids of the soil, thus developing excess pore water pressure. The gradient of the excess pore water pressure causes water to flow out of the soil according to Darcy's Law. Subsequently, the void ratio of the soil decreases, and a bigger part of the applied pressure is carried by the soil particles, which relieves a part of the excess pore water pressure. As this process continues, all the excess pore water pressure is dissipated and the applied pressure is supported completely by the soil particles. The mechanism of the classical consolidation is the development and dissipation of pore water pressures resulting in a volume reduction and a decrease in the water content of the soil.

The classical theory of consolidation as developed by Terzaghi deals only with cases of static loads. Terzaghi and Frohlich (1936) studied the progress of

consolidation during and after the application of a gradual pressure. In this case consolidation occurs simultaneously with the increase in the applied pressure. They assumed that consolidation due to every load increment proceeds independently of the consolidation due to the preceeding and succeeding load increments. They presented graphical methods for constructing time-consolidation curves for some cases of gradual application of the consolidation pressure such as construction loading of buildings or embankments.

Gibson (1958) studied the progress of consolidation of a clay layer increasing in thickness with time, by assuming certain relations between the increase in thickness and the time.

Schiffman (1958) extended the theory of consolidation to take into account the cases of time dependent loading. Using an exponential approximation for the relation between the coefficient of permeability of the soil and the excess pore water pressure, he deduced expressions for the excess pore water pressures in a soil layer subjected to different types of time dependent loadings such as construction loading and harmonic loading, taking into account the variation in the permeability during the consolidation process.

The physical nature of the consolidation process is one that has direct analogy with the theories of

rheology. Ishii (1951) analyzed the consolidation process in terms of a visco-elastic mechanical model. On the basis of his work, the theory of consolidation must be restricted to loading conditions in which the loads are imposed on the soil mass with low frequency (Schiffman 1958).

Experimental work by Wagener (1960) on repetitively loaded consolidometer samples, indicated that the consolidation settlement expected from repetitively loaded samples is equal to the settlement produced in statically loaded samples, provided that the cumulative time during which the repetitive load acts is equal to the time of application of the static load.

Skempton and Sowa (1963), Knight and Blight (1965) showed that, when a sample of soil is consolidated under a certain vertical total stress, and if this total stress is removed without change in either the water content or the volume of the sample, negative pore water pressures are set up in the sample. The magnitudes of these negative pore water pressures depend upon the vertical effective stress before unloading, the pore water pressure parameter for the release of stress " A_s " and the ratio between the horizontal and vertical effective stresses " K ".

Knight and Blight (1965) showed that loading and unloading normally consolidated undrained triaxial

specimens produced a residual positive pore water pressure. When drainage is allowed, successive cycles of loading and unloading and dissipation of the pore water pressure reduce the magnitude of the residual pore water pressure as the density and rigidity of the soil increase. Eventually, the soil is so rigid that further loading cycles produce virtually no residual pore water pressure. At this stage the soil acts completely elastic, and the curve of the settlement against the number of load applications becomes asymptotic to a maximum value.

CHAPTER III

THEORETICAL SOLUTION

To derive an equation representing the one dimensional consolidation of a soil layer subjected to cyclic loading, the following assumptions have been made:

Assumptions

- (1) The soil mass is homogeneous and isotropic.
- (2) The soil is completely saturated.
- (3) Both water and soil particles are incompressible, therefore the change in the volume of the soil mass is entirely due to drainage of water.
- (4) Water and soil particles movements are assumed to be along the vertical axis only.
- (5) Darcy's Law is valid.
- (6) The total pressure is the sum of the effective pressure and the pore water pressure. The soil comes to equilibrium under any given effective pressure.
- (7) The Coefficient of Compressibility during loading periods ($a_{vc} = \frac{-de}{dp}$), and the Coefficient of Expansion during unloading periods ($a_{ve} = \frac{de}{-dp}$) are assumed to be equal and constant for a given pressure increment.
- (8) The Coefficient of Consolidation and the Coefficient of Swelling are assumed to be equal and constant during the consolidation process.
- (9) The change in the thickness of the soil

layer during the consolidation is insignificant compared to the thickness of the layer.

The assumption of a linear relationship between the effective pressure in the soil and the void ratio, is a crude approximation for the relation between them. The only justification for its use is that a more correct relation other than the linear relationship would make the analysis very complex (Taylor 1948). The assumption that the Coefficient of Compressibility and the Coefficient of Expansion are equal is a satisfactory assumption for the reloading and unloading branches of the e-p curve for a preconsolidated soil. It is a good assumption for soils subjected to high effective pressures, but it is a poor assumption for soft soils under low effective pressures.

The assumption that the Coefficient of Consolidation and the Coefficient of Swelling are equal and constant is basically assuming that the variations in the permeability of the soil, the void ratio and the Coefficient of Compressibility or the Coefficient of Expansion tend to cancel. This introduces some error, but it is believed to be of minor importance.

The other assumptions involved in the theory are basically the same for most of the theories of consolidation and discussions about them are available in Soil Mechanics texts.

Derivation

Fig.(1) shows a section through a soil stratum subjected to cyclic loading.

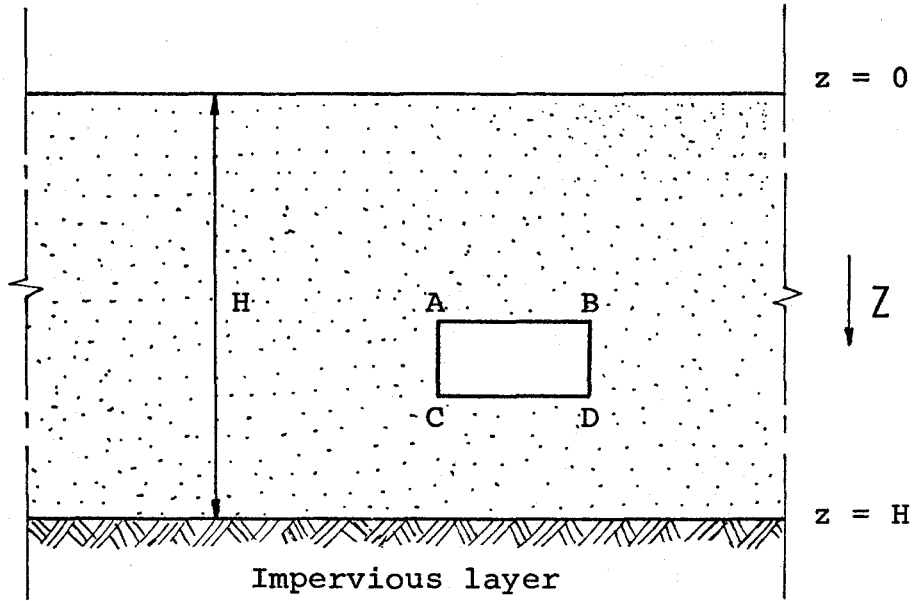

FIG.(1). SECTION THROUGH A SOIL STRATUM.

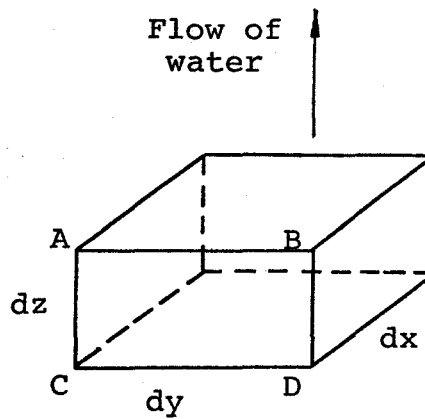

FIG.(2). FLOW THROUGH AN ELEMENT OF SOIL.

Consider an element of soil ABCD, through which is occurring a laminar flow of water in unit time q , due to consolidation of the soil stratum.

Using Darcy's Law, we get

Flow into the bottom of the element $q = k i a$

Where

k is the permeability of the soil in the z direction

i is the hydraulic gradient

a is the area of the bottom face

Then we can write

$$q = k \left(- \frac{\partial h}{\partial z} \right) dy dx$$

Flow out of the top of the element =

$$\left(k + \frac{\partial k}{\partial z} dz \right) \left(- \frac{\partial h}{\partial z} - \frac{\partial^2 h}{\partial z^2} dz \right) dy dx$$

Where h is the total head

The net flow into the element = $\Delta q =$

Flow into bottom - Flow out of top

$$\begin{aligned} \Delta q &= k \left(- \frac{\partial h}{\partial z} \right) dy dx - \left(k + \frac{\partial k}{\partial z} dz \right) \left(- \frac{\partial h}{\partial z} - \frac{\partial^2 h}{\partial z^2} dz \right) dy dx \\ &= \left(k \frac{\partial h}{\partial z} + \frac{\partial k}{\partial z} \frac{\partial h}{\partial z} dz + \frac{\partial k}{\partial z} dz \frac{\partial^2 h}{\partial z^2} \right) dx dy dz \end{aligned}$$

For constant permeability

$$\Delta q = \left(k \frac{\partial^2 h}{\partial z^2} \right) dx dy dz$$

The volume of water V_w in the element is

$$V_w = \frac{S e}{1 + e} dx dy dz$$

Where

S is the degree of saturation of the soil

e is the void ratio of the soil

For complete saturation $S = 1$, so

$$V_w = \frac{e}{1+e} dx dy dz$$

The rate of change of the water volume is

$$\Delta q = \frac{\partial V_w}{\partial t} = \frac{\partial}{\partial t} \left(\frac{e}{1+e} dx dy dz \right)$$

But $\frac{dx dy dz}{1+e}$ = Volume of solids in the element and it is assumed to be constant, so

$$\Delta q = \frac{dx dy dz}{1+e} \frac{\partial e}{\partial t}$$

Equating the two expressions in Δq , we get

$$\left(k \frac{\partial^2 h}{\partial z^2} \right) dx dy dz = \frac{dx dy dz}{1+e} \frac{\partial e}{\partial t}$$

$$k \frac{\partial^2 h}{\partial z^2} = \frac{1}{1+e} \frac{\partial e}{\partial t}$$

Introducing the relation between the effective pressure and the void ratio given by Terzaghi (1943)

$$\frac{\partial e}{\partial p} = -a_v$$

we get

$$\frac{k(1+e)}{a_v} \frac{\partial^2 h}{\partial z^2} = - \frac{\partial p}{\partial t}$$

Since

$$h = h_e + \frac{u}{\gamma_w} = h_e + \frac{1}{\gamma_w} (u_{ss} + u_e)$$

Where

h_e is the elevation head

u_{ss} is the steady state pore pressure

u_e is the excess pore pressure

Since the elevation head and the steady state pore pressure vary linearly with depth,

$$\frac{\partial^2 h_e}{\partial z^2} = \frac{\partial^2 u_{ss}}{\partial z^2} = 0$$

Hence

$$\frac{k(1+e)}{a_v \gamma_w} \frac{\partial^2 u_e}{\partial z^2} = - \frac{\partial P}{\partial t}$$

The quantity $\frac{k(1+e)}{a_v \gamma_w}$ is the Coefficient of Consolidation C_v , hence

$$C_v \frac{\partial^2 u_e}{\partial z^2} = - \frac{\partial P}{\partial t}$$

This equation can be modified by expressing the pore water pressure in terms of the total pressure and the effective pressure

$$u(z,t) = P_t(t) - P(z,t)$$

Where P_t is the total pressure; since the total pressure is a function of time only, so

$$\frac{\partial^2 u_e}{\partial z^2} = - \frac{\partial^2 P}{\partial z^2}$$

Thus the equation governing the one dimensional consolidation of a soil layer subjected to cyclic loading is

$$C_v \frac{\partial^2 P(z,t)}{\partial z^2} = \frac{\partial P(z,t)}{\partial t} \quad (1)$$

The initial and boundary conditions are

$$(1) P = 0 \quad \text{for } 0 \leq z \leq H \quad t = 0 \quad (2)$$

$$(2) \frac{\partial P}{\partial z} = 0 \quad \text{for } z = H \quad t \geq 0 \quad (3)$$

$$(3) P = P_t = \phi(t) \quad \text{for } z = 0 \quad t \geq 0 \quad (4)$$

Where $\phi(t)$ is the uniform cyclic wave loading represented by

$$\phi(t) = P \quad rT < t < rT + T1 \quad r=0,1,2,\dots \quad (5)$$

$$= 0 \quad rT + T1 < t < (r + 1)T \quad (6)$$

Which means that the pressure is "on" for a period ($T1$) and "off" for a period ($T - T1$).

This problem is a one dimensional boundary value problem with nonhomogeneous boundary conditions. The solution is obtained using the integral transform technique.

The integral transform and the inversion formula of the pressure function $P(z, t)$ with respect to the space variable z in the region $0 \leq z \leq H$ are

$$\bar{P}(\lambda_m, t) = \int_0^H k(\lambda_m, z) \cdot P(z, t) \cdot dz \quad (7)$$

$$P(z, t) = \sum_{m=1}^{\infty} k(\lambda_m, z) \cdot \bar{P}(\lambda_m, t) \quad (8)$$

Where $k(\lambda_m, z)$ is called the transform kernel, and it is the normalized eigenfunctions of the auxiliary eigenvalue problem defined by

$$\frac{\partial^2 \Psi(z)}{\partial z^2} + \lambda^2 \Psi(z) = 0 \quad \text{in } 0 \leq z \leq H \quad (9)$$

with boundary conditions

$$\frac{\partial \Psi(z)}{\partial z} = 0 \quad z = H \quad (10)$$

$$\Psi(z) = 0 \quad z = 0 \quad (11)$$

The types of the kernels and the eigenvalues to be used in the integral transform and the inversion formula depend upon the boundary conditions of the problem.

Applying the integral transform equation (7) to equation (1), we get

$$C_V \int_0^H k(\lambda_m, z) \cdot \frac{\partial^2 P(z, t)}{\partial z^2} \cdot dz = \int_0^H k(\lambda_m, z) \cdot \frac{\partial P(z, t)}{\partial t} \cdot dz \quad (12)$$

Which can be written in the form

$$C_V \int_0^H k(\lambda_m, z) \cdot \frac{\partial^2 P(z, t)}{\partial z^2} \cdot dz = \frac{d\bar{P}(\lambda_m, t)}{dt} \quad (13)$$

Where the quantity (\bar{P}) refers to the integral transform according to equation (7).

The integral on the left hand side of equation (13) is the integral transform of $\frac{\partial^2 P(z, t)}{\partial z^2}$. This integral can be evaluated using Green's function, which can be written in the form

$$\int_0^H k_m \cdot \frac{\partial^2 P(z, t)}{\partial z^2} \cdot dz = \int_0^H P \frac{\partial^2 k_m}{\partial z^2} \cdot dz + \sum_{i=1}^s \int_0^H [k_m \frac{\partial P}{\partial n_i} - P \frac{\partial k_m}{\partial n_i}] ds_i \quad (14)$$

Where $k_m \equiv k(\lambda_m, z)$ and $P \equiv P(z, t)$; and the summation is taken over all the continuous bounding surfaces $i = 1, 2, 3, \dots, s$.

The first term on the right hand side of equation

(14) is obtained by multiplying the auxiliary equation (9) by the pressure function P and integrating over the region $0 \leq z \leq H$

$$\int_0^H P \cdot \frac{\partial^2 k_m}{\partial z^2} \cdot dz = - \lambda_m^2 \cdot \int_0^H k_m \cdot P \cdot dz$$

$$= - \lambda_m^2 \cdot \bar{P}(\lambda_m, t) \quad (15)$$

The second term on the right hand side of equation (14) is evaluated using the boundary conditions (3), (4), (10) and (11), which can be written in the form

$$L_i \frac{\partial P(z, t)}{\partial n_i} + h_i P(z, t) = f_i(z, t) \quad (16)$$

$$L_i \frac{\partial \Psi(z)}{\partial n_i} + h_i \Psi(z) = 0 \quad (17)$$

Where i represents the boundary under consideration.

For the boundary condition (3)

$$L_1 = 1 \quad h_1 = 0 \quad f_1(z, t) = 0$$

and the boundary condition (4)

$$L_2 = 0 \quad h_2 = 1 \quad f_2(z, t) = \phi(t)$$

From equations (16) and (17) we get

$$\left[k_m \frac{\partial P}{\partial n_i} - P \frac{\partial k_m}{\partial n_i} \right] = \frac{1}{h_i} \cdot \frac{dk(\lambda_m, z)}{dn_i} \cdot f_i(z, t) \quad (18)$$

Substituting from equations (15) and (18) into (14)

$$\int_0^H k_m \frac{\partial^2 P}{\partial z^2} \cdot dz = - \lambda_m^2 \cdot \bar{P}(\lambda_m, t) +$$

$$\sum_{i=1}^S \int_{s_i} \frac{1}{h_i} \cdot \frac{dk(\lambda_m, z)}{dn_i} \cdot f_i(z, t) \cdot ds_i \quad (19)$$

Substituting equation (19) into (13)

$$\int_0^H k(\lambda_m, z) \cdot \frac{\partial^2 P(z, t)}{\partial z^2} \cdot dz = -\lambda_m^2 \cdot \bar{P}(\lambda_m, t) +$$

$$\left[\left| \frac{1}{h} \cdot \frac{dk(\lambda_m, z)}{dz} \right|_{z=0} \cdot \phi(t) \right]$$

$$= -\lambda_m^2 \cdot \bar{P}(\lambda_m, t) +$$

$$\left[\left| \frac{dk(\lambda_m, z)}{dz} \right|_{z=0} \cdot \phi(t) \right]$$

Then

$$\frac{d \bar{P}(\lambda_m, t)}{dt} + C_v \cdot \lambda_m^2 \cdot \bar{P}(\lambda_m, t) = A(\lambda_m, t) \quad (20)$$

Where

$$A(\lambda_m, t) = C_v \left[\left| \frac{dk(\lambda_m, z)}{dz} \right|_{z=0} \cdot \phi(t) \right]$$

Thus the second partial derivative with respect to the space variable z is removed from the problem and it is reduced to a first order ordinary differential equation with respect to the time variable t for the integral transform of the pressure function $\bar{P}(\lambda_m, t)$.

The initial condition for equation (20) is obtained by taking the integral transform of the initial condition (2), then

$$\bar{P}(\lambda_m, t) \Big|_{t=0} = \int_0^H k(\lambda_m, z) \cdot F(z) \cdot dz$$

Where $F(z) = P(z, 0) = 0$

Thus $\bar{P}(\lambda_m, t) \Big|_{t=0} = 0 \quad (21)$

Then the solution of the equation (20) subject to

the transformed boundary condition (21) is

$$\bar{P}(\lambda_m, t) = e^{-C_v \lambda_m^2 t} \left[\int_0^t e^{C_v \lambda_m^2 t'} \cdot A(\lambda_m, t') \cdot dt' \right] \quad (22)$$

Substituting the integral transform -equation (22)- into the inversion formula -equation (8)- we get

$$P(z, t) = \sum_{m=1}^{\infty} e^{-C_v \lambda_m^2 t} \cdot k(\lambda_m, z) \int_0^t e^{C_v \lambda_m^2 t'} \cdot A(\lambda_m, t') \cdot dt' \quad (23)$$

Where

$$A(\lambda_m, t) = C_v \left[\left| \frac{dk(\lambda_m, z)}{dz} \right|_{z=0} \cdot \phi(t) \right]$$

The kernel and the eigenvalues are obtained by solving the auxiliary differential equation (9) subject to the boundary conditions (10) and (11). So,

$$k(\lambda_m, z) = \sqrt{\frac{2}{H}} \text{SIN} \lambda_m z$$

The eigenvalues are the roots of

$$\text{COS} \lambda_m H = 0$$

So

$$\lambda_m = \frac{(2m+1)\pi}{2H} \quad m = 0, 1, 2, \dots$$

Then we get

$$\begin{aligned} A(\lambda_m, t) &= C_v \left[\left| \frac{dk(\lambda_m, z)}{dz} \right|_{z=0} \cdot \phi(t) \right] \\ &= C_v \sqrt{\frac{2}{H}} \cdot \lambda_m \cdot \phi(t) \end{aligned}$$

Then applying in equation (23), we get

$$P(z, t) = \frac{2C_v}{H} \sum_{m=0}^{\infty} e^{-C_v \lambda_m^2 t} \cdot \lambda_m \cdot \text{SIN} \lambda_m z \cdot \int_0^t e^{C_v \lambda_m^2 t'} \cdot \phi(t') \cdot dt'$$

$$P(z, t) = \frac{2C_v}{H} \sum_{m=0}^{\infty} \lambda_m \cdot \text{SIN} \lambda_m z \cdot e^{-C_v \lambda_m^2 t} \int_0^t e^{C_v \lambda_m^2 t'} \cdot \phi(t') \cdot dt' \quad (24)$$

To evaluate the quantity $e^{-C_v \lambda_m^2 t} \int_0^t e^{C_v \lambda_m^2 t'} \cdot \phi(t') \cdot dt'$ and derive the expression for the pressure function $P(z, t)$, the values of the loading function $\phi(t)$ in (5) and (6) are introduced.

$$\text{Putting } t = rT + t_1 \quad 0 < t_1 < T$$

$$\text{and } \alpha_m = C_v \cdot \lambda_m^2, \text{ then}$$

$$\begin{aligned} & e^{-\alpha_m t} \int_0^t e^{\alpha_m t'} \cdot \phi(t') \cdot dt' = \\ & = P' e^{-\alpha_m t} \left[\int_0^{T1} + \int_T^{T+T1} + \dots + \int_{(r-1)T}^{(r-1)T+T1} + \int_{rT}^{rT+t_1} e^{\alpha_m t'} \cdot dt' \right] \\ & = \frac{P'}{\alpha_m} e^{-\alpha_m t} \left[(e^{\alpha_m T1} - e^{\alpha_m T}) \sum_{s=0}^{r-1} e^{s\alpha_m T} - 1 + e^{\alpha_m (rT+t_1)} \right] \\ & = \frac{P'}{\alpha_m} e^{-\alpha_m t} \left[\frac{(e^{\alpha_m T1} - e^{\alpha_m T})(1 - e^{r\alpha_m T})}{(1 - e^{\alpha_m T})} - 1 + e^{\alpha_m t} \right] \\ & = \frac{P'}{\alpha_m} \left[\frac{e^{\alpha_m (T1-t)} - e^{\alpha_m (T-t)}}{1 - e^{\alpha_m T}} - \frac{e^{\alpha_m (T1-t_1)} - e^{\alpha_m (T-t_1)}}{1 - e^{\alpha_m T}} + 1 - e^{-\alpha_m t} \right] \end{aligned}$$

Then substituting in equation (24) we get

$$\begin{aligned} P(z, t) = \frac{4 P'}{\pi} \sum_{m=0}^{\infty} \frac{1}{2m+1} \cdot \text{SIN}(Mz) \cdot \left[1 - \frac{e^{\alpha_m (T1-t_1)} - e^{\alpha_m (T-t_1)}}{1 - e^{\alpha_m T}} \right. \\ \left. + \frac{e^{-\alpha_m (t-T1)} - e^{-\alpha_m (t-T)}}{1 - e^{\alpha_m T}} - e^{-\alpha_m t} \right] \end{aligned}$$

$$\text{Where } M = \frac{(2m+1)\pi}{2} \quad z = \frac{z}{H} \quad \alpha_m = C_v \frac{M^2}{H^2}$$

Since

$$\frac{4}{\pi} \sum_{m=0}^{\infty} \frac{1}{2m+1} \cdot \text{SIN}(MZ) = 1$$

Then the effective pressure during periods of load applications is

$$P(z, t) = P' - \frac{4 P'}{\pi} \sum_{m=0}^{\infty} \frac{1}{2m+1} \cdot \text{SIN}(MZ) \cdot \left[\frac{e^{\alpha_m(Tl-t_1)} - e^{\alpha_m(T-t_1)}}{1 - e^{\alpha_m T}} - \frac{e^{-\alpha_m(t-Tl)} - e^{-\alpha_m(t-T)}}{1 - e^{\alpha_m T}} + e^{-\alpha_m t} \right] \quad (25)$$

and the consolidation ratio U_z is

$$U_z = 1 - \frac{4}{\pi} \sum_{m=0}^{\infty} \frac{1}{2m+1} \cdot \text{SIN}(MZ) \cdot \left[\frac{e^{\alpha_m(Tl-t_1)} - e^{\alpha_m(T-t_1)}}{1 - e^{\alpha_m T}} - \frac{e^{-\alpha_m(t-Tl)} - e^{-\alpha_m(t-T)}}{1 - e^{\alpha_m T}} + e^{-\alpha_m t} \right] \quad (26)$$

The average consolidation ratio in the soil layer is given by

$$U_{av} = \frac{1}{H} \int_0^H U_z \cdot dz \quad (27)$$

Substituting equation (26) into equation (27) we get

$$U_{av} = 1 - \frac{8}{\pi^2} \sum_{m=0}^{\infty} \frac{1}{(2m+1)^2} \left[\frac{e^{\alpha_m(Tl-t_1)} - e^{\alpha_m(T-t_1)}}{1 - e^{\alpha_m T}} - \frac{e^{-\alpha_m(t-Tl)} - e^{-\alpha_m(t-T)}}{1 - e^{\alpha_m T}} + e^{-\alpha_m t} \right] \quad (28)$$

In order to get the value of the effective pressure during a period of load removal, we follow the same procedure. Putting $t = rT + T_1 + t_2$ where $0 < t_2 < T - T_1$ in equation (24), and evaluate the quantity

$$\begin{aligned}
 & e^{-\alpha_m t} \int_0^t e^{\alpha_m t'} \cdot \phi(t') \cdot dt' = \\
 & = P' e^{-\alpha_m t} \left[\int_0^{T_1} + \int_T^{T+T_1} + \dots + \int_{(r-1)T}^{(r-1)T+T_1} + \int_{rT}^{rT+T_1} e^{\alpha_m t'} dt' \right] \\
 & = \frac{P'}{\alpha_m} e^{-\alpha_m t} \left[(e^{\alpha_m T_1} - e^{\alpha_m T}) \sum_{s=0}^{r-1} e^{s\alpha_m T} - 1 + e^{\alpha_m (rT+T_1)} \right] \\
 & = \frac{P'}{\alpha_m} e^{-\alpha_m t} \left[\frac{(e^{\alpha_m T_1} - e^{\alpha_m T})(1 - e^{r\alpha_m T})}{(1 - e^{\alpha_m T})} - 1 + e^{\alpha_m (rT+T_1)} \right] \\
 & = \frac{P'}{\alpha_m} \left[\frac{e^{\alpha_m (T-T_1-t_2)} - e^{\alpha_m (T-t_2)}}{1 - e^{\alpha_m T}} + \frac{e^{-\alpha_m (t-T_1)} - e^{-\alpha_m (t-T)}}{1 - e^{\alpha_m T}} - e^{-\alpha_m t} \right]
 \end{aligned}$$

Thus the effective pressure during periods of load removal is given by

$$\begin{aligned}
 P(z, t) = \frac{4 P'}{\pi} \sum_{m=0}^{\infty} \frac{1}{2m+1} \cdot \text{SIN}(MZ) & \left[\frac{e^{\alpha_m (T-T_1-t_2)} - e^{\alpha_m (T-t_2)}}{1 - e^{\alpha_m T}} \right. \\
 & \left. + \frac{e^{-\alpha_m (t-T_1)} - e^{-\alpha_m (t-T)}}{1 - e^{\alpha_m T}} - e^{-\alpha_m t} \right] \quad (29)
 \end{aligned}$$

and the consolidation ratio U_z is

$$U_z = \frac{4}{\pi} \sum_{m=0}^{\infty} \frac{1}{2m+1} \cdot \text{SIN}(MZ) \left[\frac{e^{\alpha_m(T-T_1-t_2)} - e^{\alpha_m(T-t_2)}}{1 - e^{\alpha_m T}} + \frac{e^{-\alpha_m(t-T_1)} - e^{-\alpha_m(t-T)}}{1 - e^{\alpha_m T}} - e^{-\alpha_m t} \right] \quad (30)$$

After the elapse of theoretically infinite time, equations (26) and (30) become

$$U_z = 1 - \frac{4}{\pi} \sum_{m=0}^{\infty} \frac{1}{2m+1} \cdot \text{SIN}(MZ) \left[\frac{e^{\alpha_m(T_1-t_1)} - e^{\alpha_m(T-t_1)}}{1 - e^{\alpha_m T}} \right] \quad (31)$$

$$U_z = \frac{4}{\pi} \sum_{m=0}^{\infty} \frac{1}{2m+1} \cdot \text{SIN}(MZ) \left[\frac{e^{\alpha_m(T-T_1-t_2)} - e^{\alpha_m(T-t_2)}}{1 - e^{\alpha_m T}} \right] \quad (32)$$

for periods of load application and load removal respectively.

The consolidation ratio for cyclic loading given by equations (26) and (30) is a special case of the classical consolidation ratio for sustained loadings; it can also be referred to as the normalized effective pressures.

The values of the consolidation ratio U_z given by equations (26), (30), (31) and (32) were obtained using the computer CDC/6400 at McMaster University. The number of terms used in the series and consequently the accuracy of the numerical values of U_z are dependent upon the values of the parameters used and the computer capacity.

CHAPTER IV

DISCUSSION OF THE THEORETICAL SOLUTION

The theoretical process of consolidation of a soil layer subjected to cyclic loading is described by equations (26) and (30), which represent the consolidation ratio for the layer during periods of load application and load removal respectively. These equations have been plotted in figs. (3) to (8) using a representative range of values for the stratum thickness, the soil properties and the loading characteristics.

The two equations can be represented by two sets of curves; one set of curves for periods of load application and the other set of curves for periods of load removal. These curves show that, in the early stages of consolidation the soil adjacent to the drainage boundary is consolidating, while the soil adjacent to the impervious boundary has not experienced any change in the effective stress. Even though the consolidation progresses most rapidly in the soil adjacent to the drainage boundary and least rapidly in the soil adjacent to the impervious boundary, pore water pressures must exist within the soil adjacent to the drainage boundary to provide the necessary gradient for the flow of water and such pore water pressures must persist as long as there are pore water pressures within the soil layer.

As consolidation proceeds, the positive pore water pressure during periods of load application decreases, and the negative pore water pressure during periods of load removal increases.

As time goes on, the consolidation ratio at every point in the soil layer increases. Finally, after the elapse of theoretically infinite time, the consolidation ratio reaches a maximum value throughout the soil layer; which means that the pore water pressures in the layer reach a steady state condition. This indicates that, in the steady state condition the positive pore pressures in the layer reach their maximum value at the beginning of the loading period, and then decrease during the period. It also indicates that, when the soil is unloaded the negative pore water pressures reach their maximum value at the beginning of the period, and then decrease during the period. When the soil layer is loaded again, the positive pore water pressures will have the same maximum value at the beginning of the period and then decrease, and when it is unloaded again, the negative pore water pressures will have the same maximum value at the beginning of the period and then decrease again, and this process will continue indefinitely.

The decrease in the positive and negative pore water pressures when the soil is loaded and unloaded in the steady state condition depends upon the stratum

thickness, the soil properties and the cyclic loading characteristics.

The physical process of consolidation of a soil layer subjected to cyclic loading can be explained as follows. When the load is applied to the saturated soil in the first application, the entire load is carried by the water in the pores of the soil as excess pore water pressure. The gradient of the excess pore water pressure causes flow of water out of the soil, and consequently there is a decrease in the excess pore water pressure. Thus a part of the load is transferred to the soil structure causing an increase in the effective pressure between the soil particles according to the effective pressure principle. When the load is removed, the total pressure is reduced and consequently negative pore water pressures are set up in the soil. These negative pore water pressures cause water to flow into the soil, which results a decrease in these negative pore water pressures and consequently a decrease in the effective pressure. When the soil is loaded again, a part of the load is carried by the residual effective pressure and the rest is carried by the water as excess pore water pressure. As consolidation proceeds, the excess pore water pressure decreases and the effective pressure increases when the soil is loaded; and the negative pore water pressure increases when the soil is unloaded.

As the cycles of loading and unloading continue, this process continues until the soil reaches a state in which the amount of water flowing out due to the positive pore water pressure is equal to the amount of water flowing into the soil due to the negative pore water pressure. In this state the pore water pressure and the effective pressure have final equilibrium values, and this is the steady state condition under cyclic loading.

The consolidation ratio during the consolidation process depends upon the thickness of the soil layer, the soil properties, the cyclic load characteristics and the elapsed time. The influence of these different parameters is investigated. Figs. (3) and (4) show the progress of consolidation in two soil layers having different coefficients of consolidation and subjected to the same cyclic loading. It can be seen that consolidation proceeds more rapidly in the soil layer which has the greater coefficient of consolidation.

The equilibrium consolidation ratio depends upon the load characteristics. Figs. (4) and (6) show that the equilibrium consolidation ratio is proportional to the cycle ratio (T_l/T) which is the ratio between the duration time of the load and the total time of the cycle. The relation between the equilibrium consolidation ratio and the cycle ratio (T_l/T) is shown in

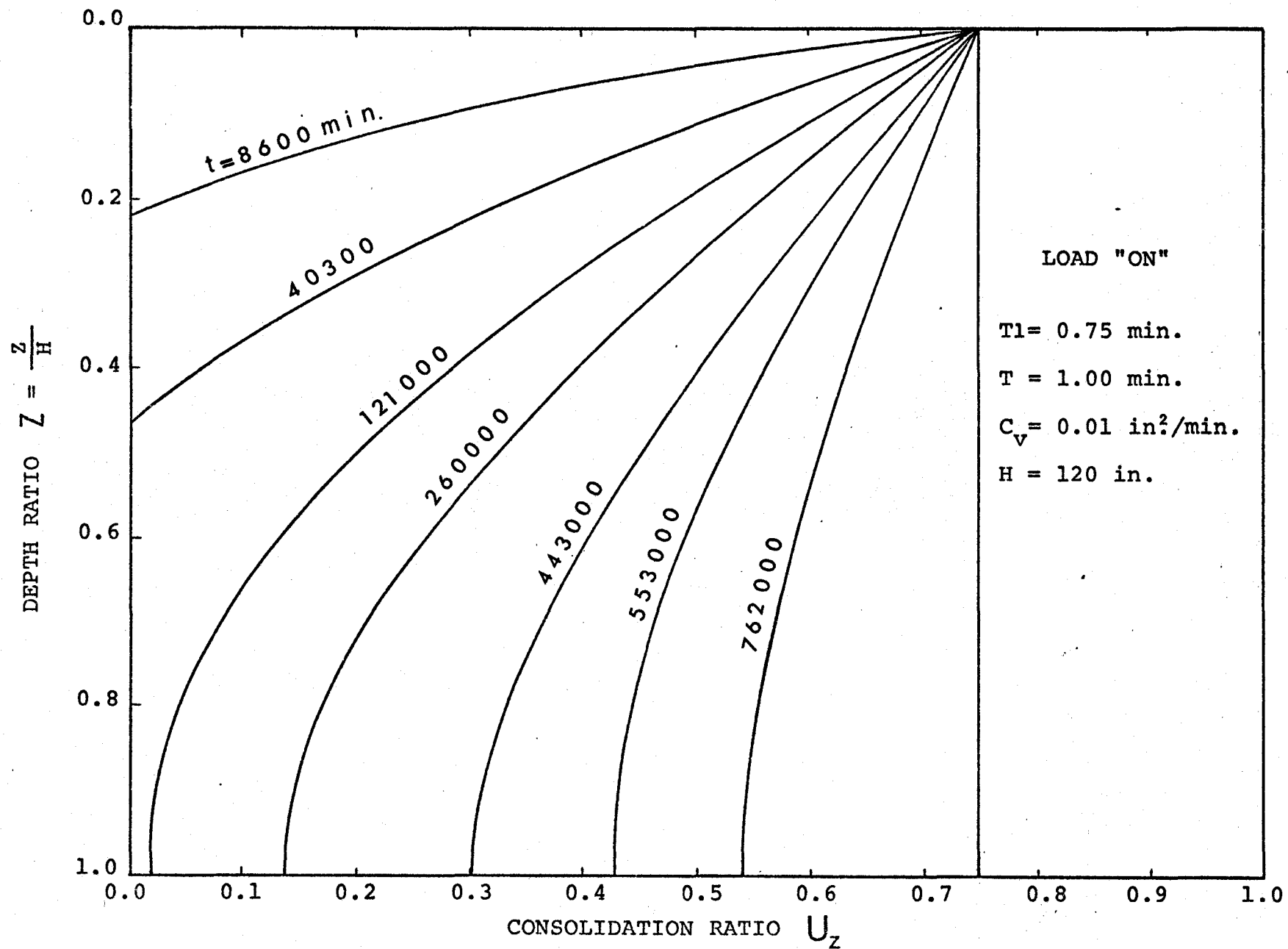

FIG. (3). CONSOLIDATION RATIO AS A FUNCTION OF DEPTH AND ELAPSED TIME.

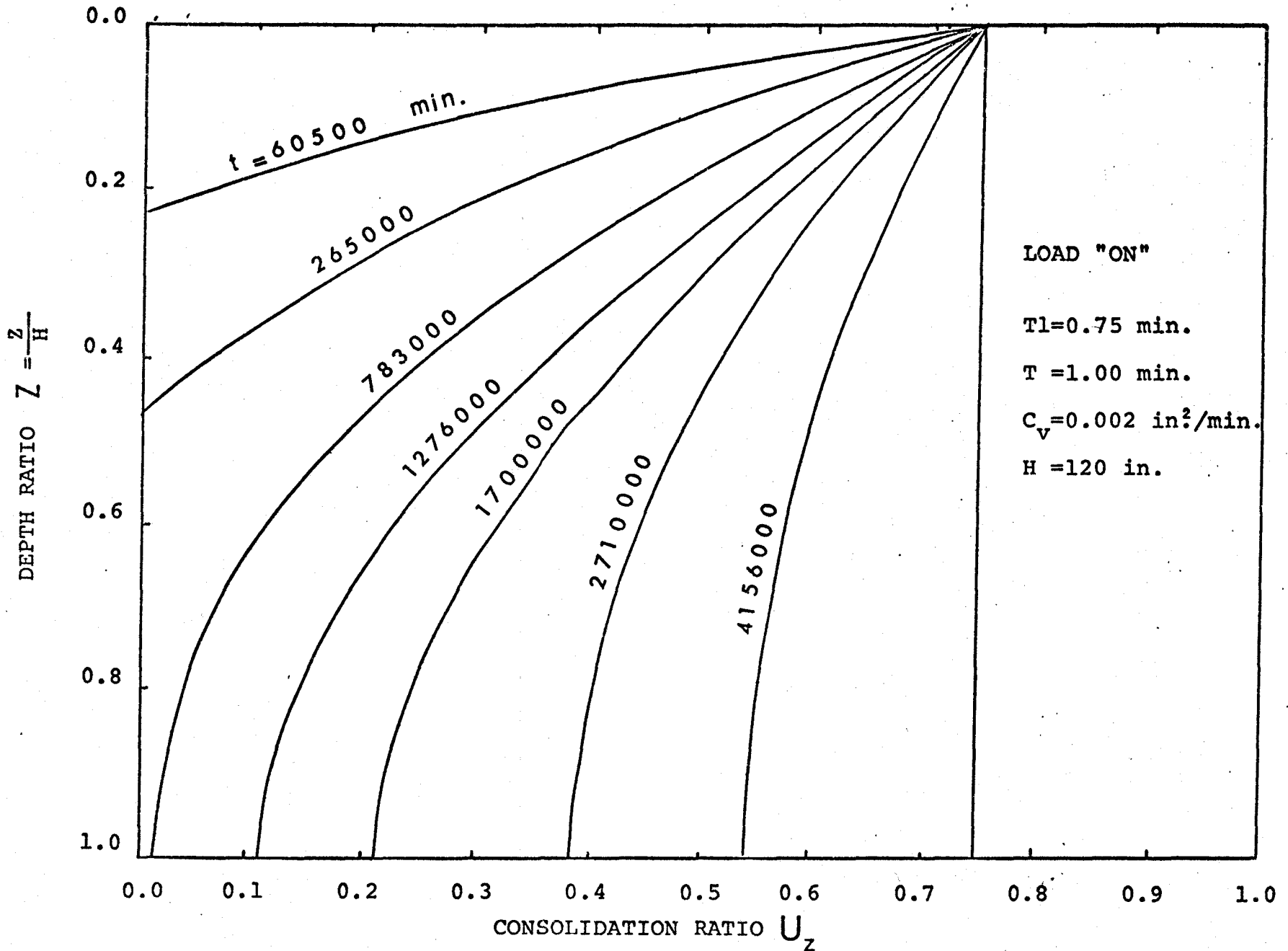

FIG.(4). CONSOLIDATION RATIO AS A FUNCTION OF DEPTH AND ELAPSED TIME.

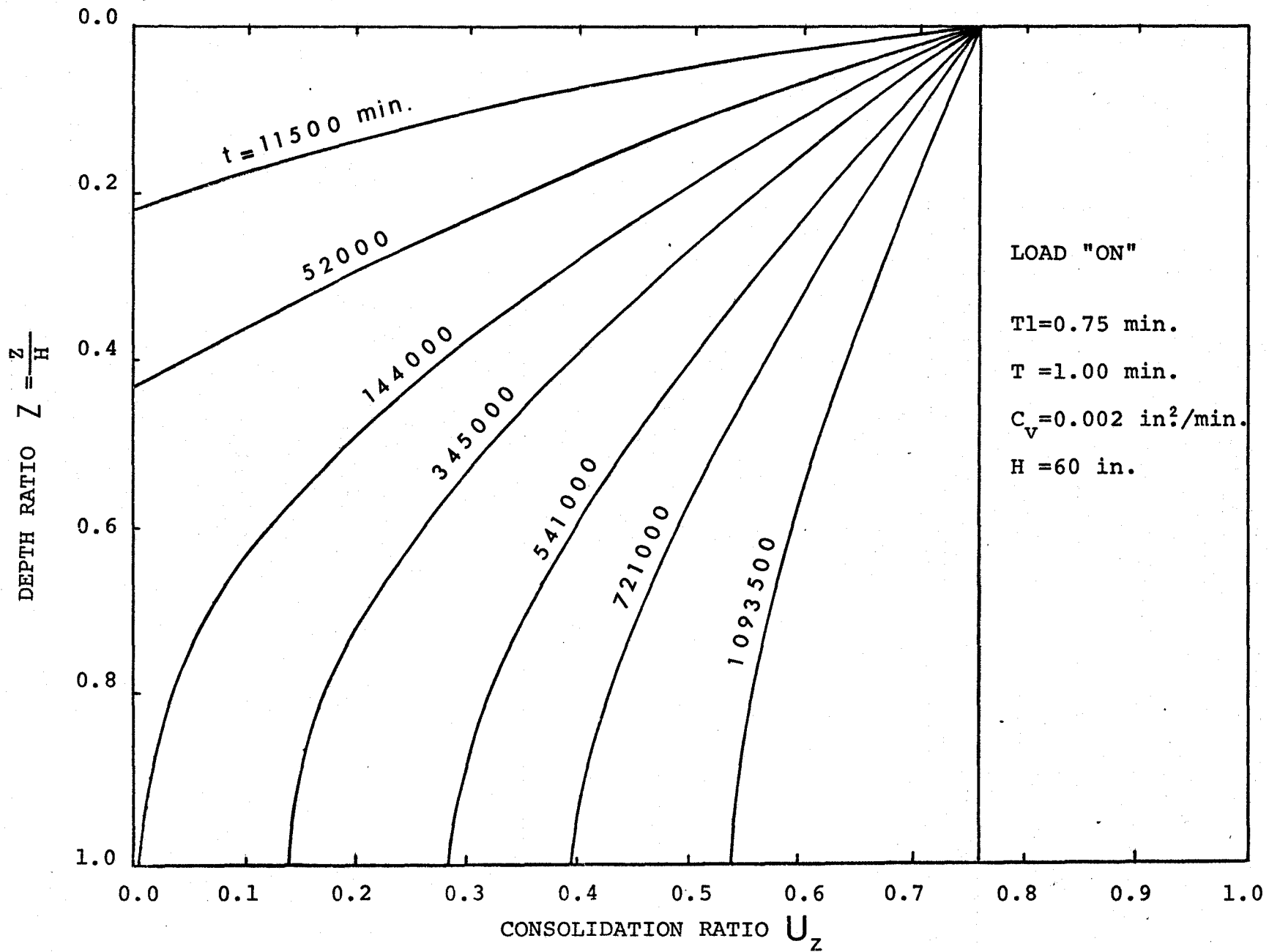

FIG. (5). CONSOLIDATION RATIO AS A FUNCTION OF DEPTH AND ELAPSED TIME.

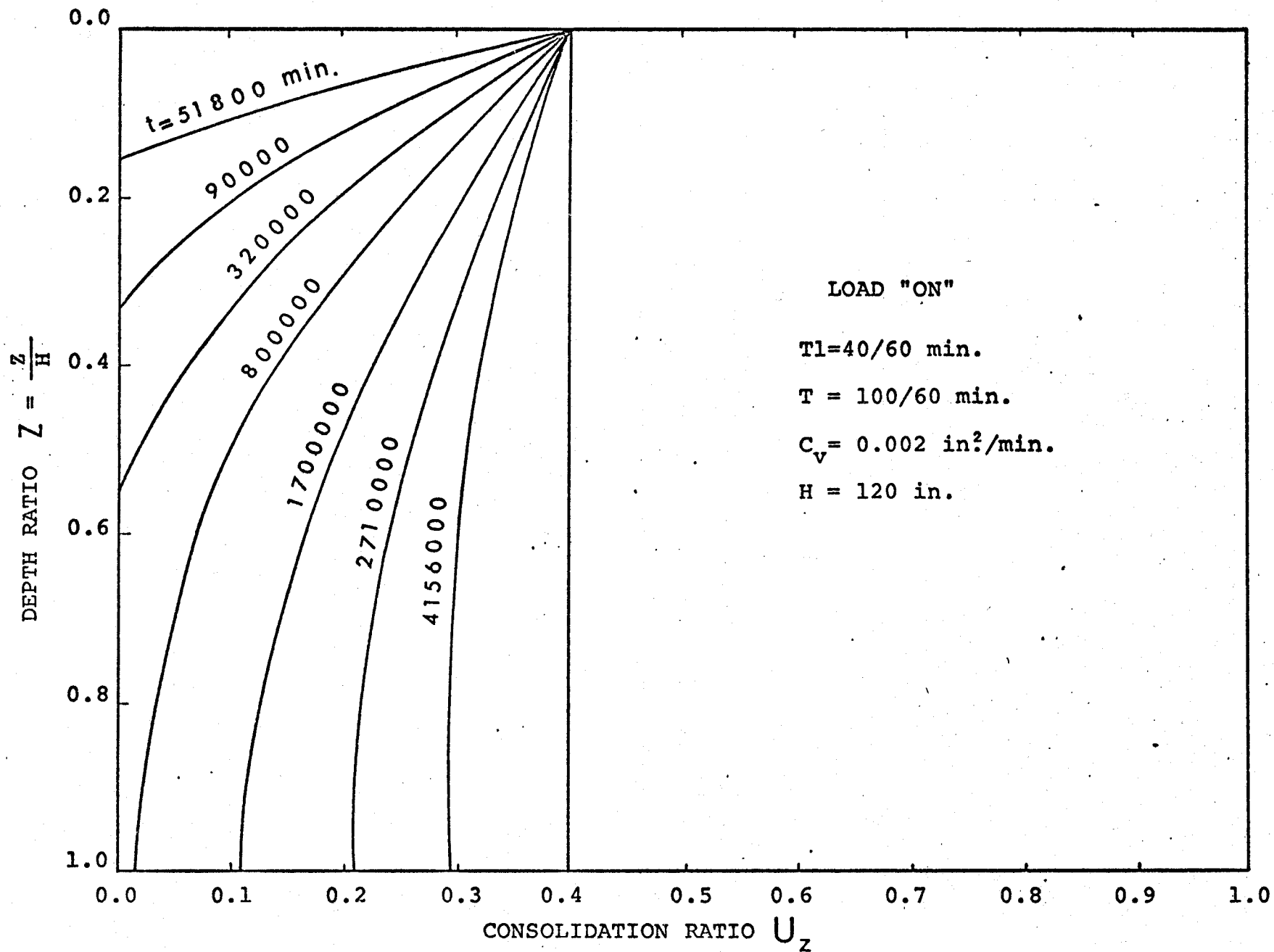

FIG. (6). CONSOLIDATION RATIO AS A FUNCTION OF DEPTH AND ELAPSED TIME.

Fig.(7). It can be seen that the equilibrium consolidation ratio corresponding to the cycle ratio (T_1/T) equal to unity-which in fact is the case of a sustained load- is 1.0 . This can be also seen by putting $T_1=T$ in equation (26), as the result will be the consolidation ratio due to a sustained load as derived from Terzaghi's consolidation equation.

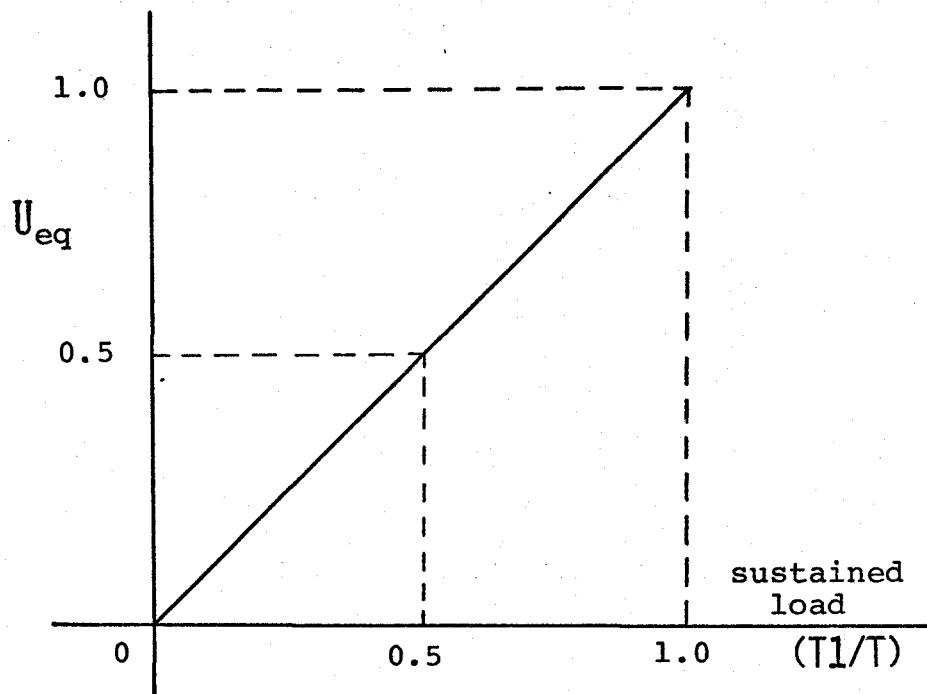

FIG.(7). RELATION BETWEEN THE EQUILIBRIUM CONSOLIDATION RATIO AND THE CYCLE RATIO (T_1/T).

The consolidation ratio for the periods of load application and load removal is shown in Fig.(8). It can be seen that the consolidation ratio in the equilibrium condition is the same for periods of load application and load removal.

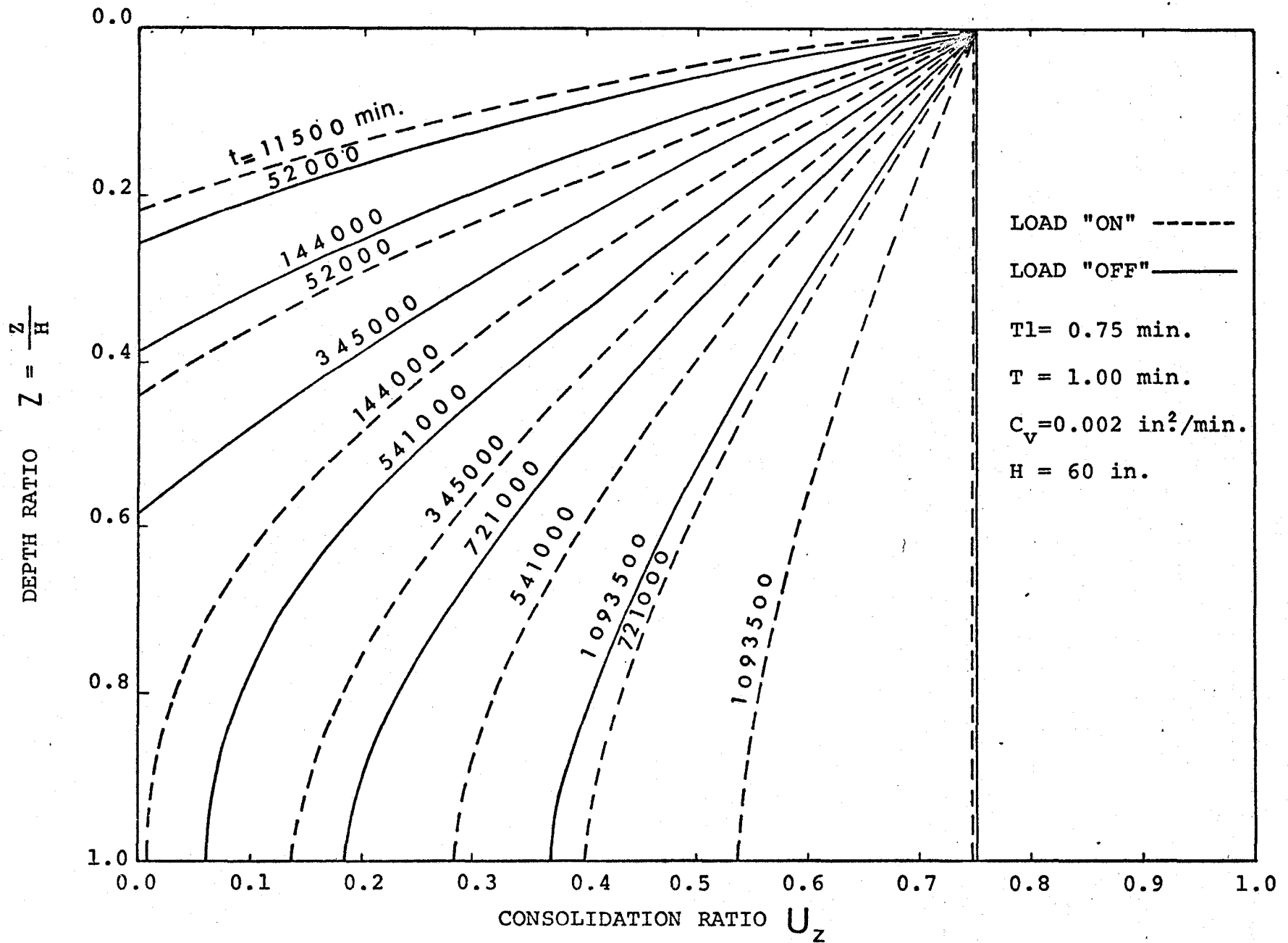

FIG. (8). CONSOLIDATION RATIO AS A FUNCTION OF DEPTH AND ELAPSED TIME.

A comparison between the progress of consolidation due to a sustained load and due to a cyclic load is shown in Fig. (9); which shows that the consolidation due to the sustained load proceeds more rapidly than the consolidation due to the cyclic load. This is due to the fact that, while consolidation due to the sustained load proceeds continually, the consolidation due to the cyclic load proceeds only when the soil is loaded and swelling takes place when the soil is unloaded. This process delays the progress of consolidation due to the cyclic load because a part of the expelled water during consolidation is sucked back into the soil during swelling. The successive cycles of consolidation and swelling under the cyclic load prevent the equilibrium consolidation ratio due to the cyclic loading from reaching 1.0, while the final consolidation ratio due to the sustained load is 1.0. Fig. (10) shows the average consolidation ratio versus the elapsed time for a soil layer subjected to a cyclic load or a sustained load. It can be seen that the final consolidation ratio for the sustained load and the equilibrium consolidation ratio for the cyclic load are reached at approximately the same time.

The term "equilibrium" was used to denote the consolidation ratio at the steady state condition; other terms can be also used such as "stationary" or "stable".

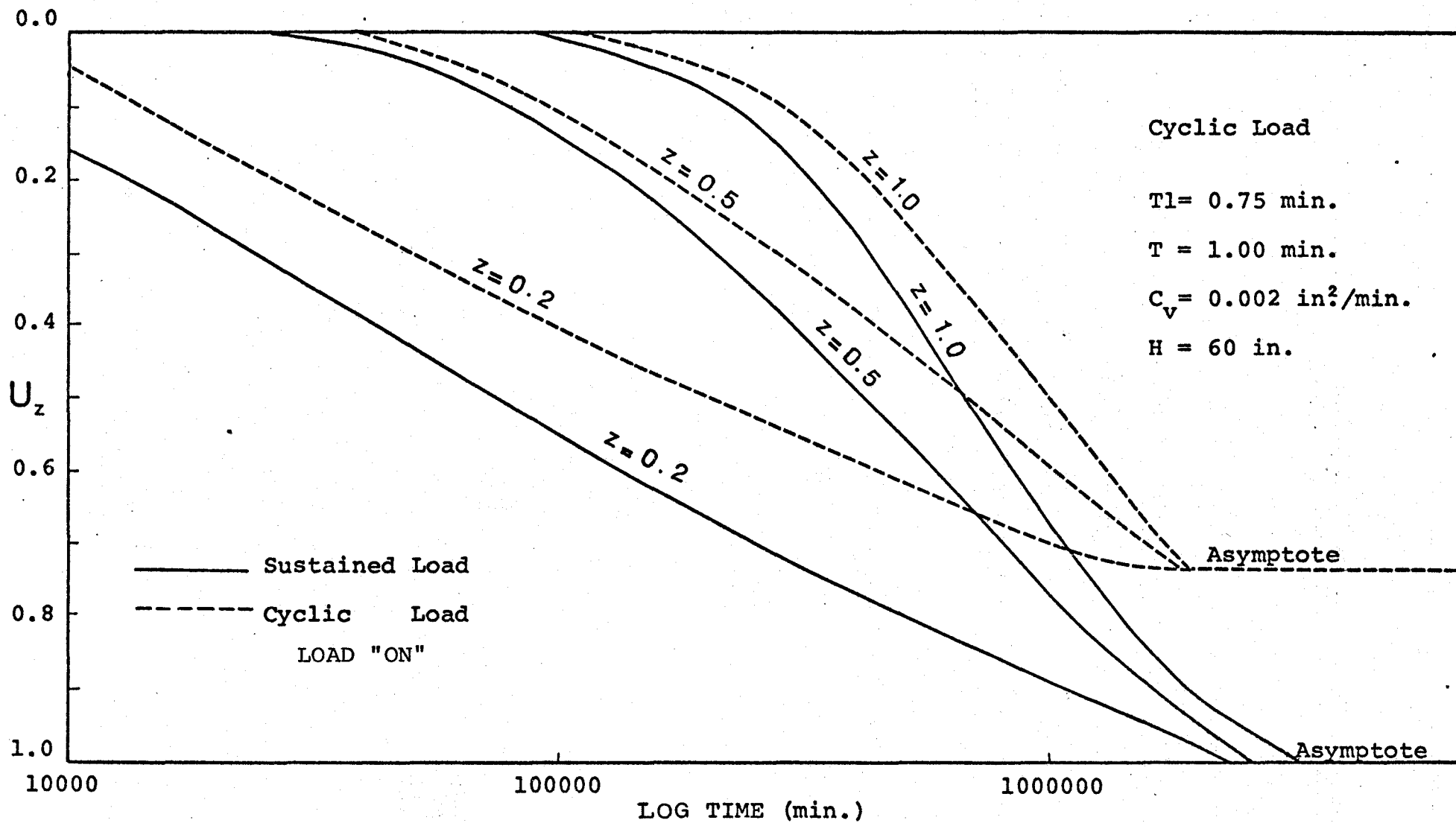

FIG.(9). CONSOLIDATION RATIO VERSUS TIME FOR CYCLIC AND SUSTAINED LOADINGS.

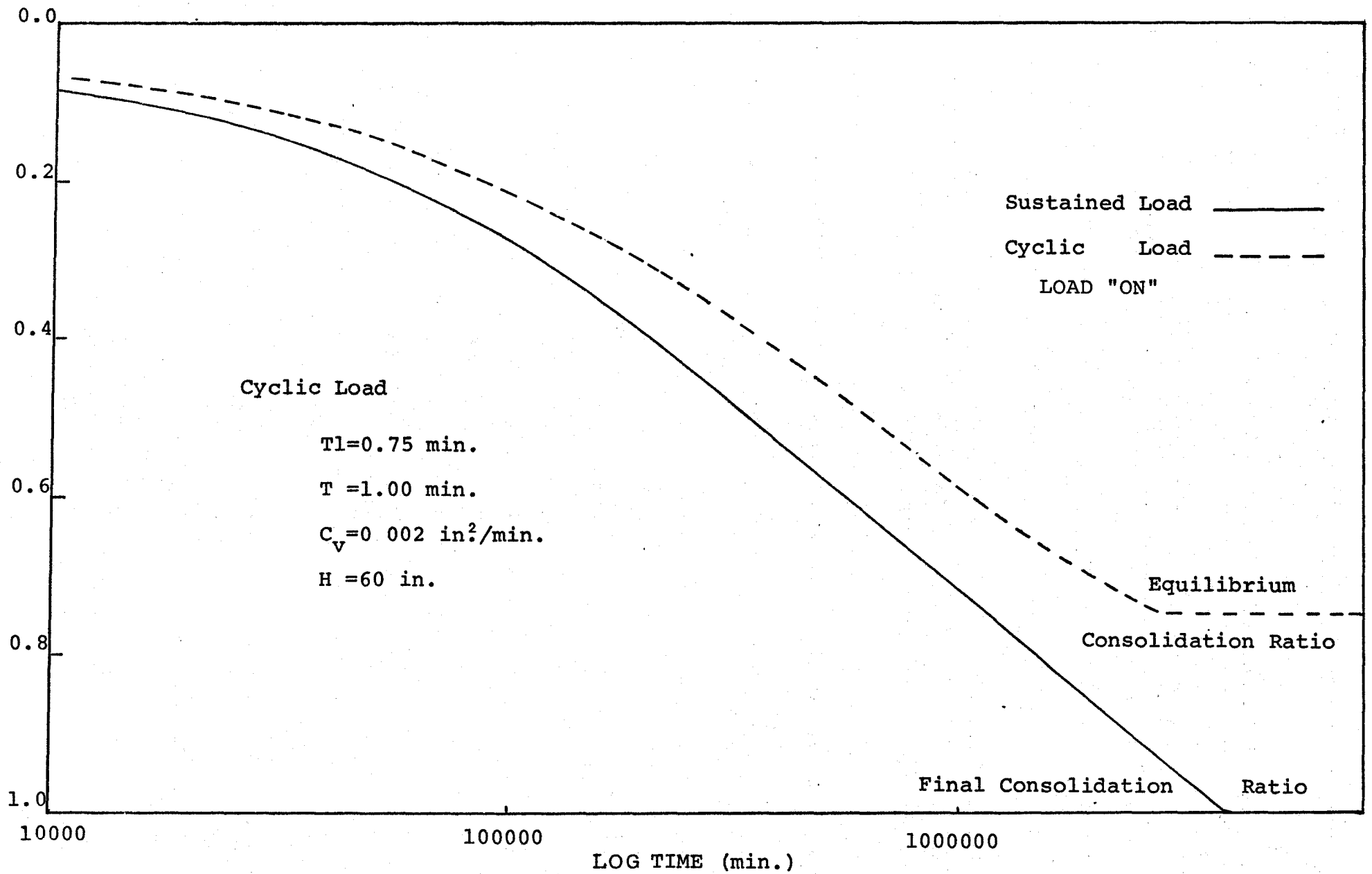

FIG. (10). AVERAGE CONSOLIDATION RATIO VERSUS TIME FOR CYCLIC AND SUSTAINED LOADINGS .

CHAPTER V

EXPERIMENTAL APPARATUS AND PROCEDURE

Experimental Apparatus

The consolidometer used in the experimental work is a modified version of Rowe's consolidometer; the total stresses were applied to the samples using hydraulic pressures. Pore water pressure measurements were taken at various levels in the samples using pressure transducers. Settlements of the samples were measured using a dial gauge. Fig. (11) shows the consolidometer.

A) The Consolidometer: The consolidometer consists of a lucite cylinder, a brass base and cover.

The lucite cylinder is 12" high, 3" diameter and $\frac{1}{4}$ " thick. For pore pressure measurements at various levels in the samples, three transducer housings were fixed to the cylinder wall.

The stresses were applied to the samples using the self-compensating Mercury cylinders used for applying the confining pressures in the triaxial testing; cyclic loadings were obtained by alternating from one Mercury cylinder to another using a three-way valve. The stresses were transferred to the samples through a thin rubber diaphragm. The centre of the rubber diaphragm was attached to a brass spindle passing through the cover, so that settlements of the samples can be measured.

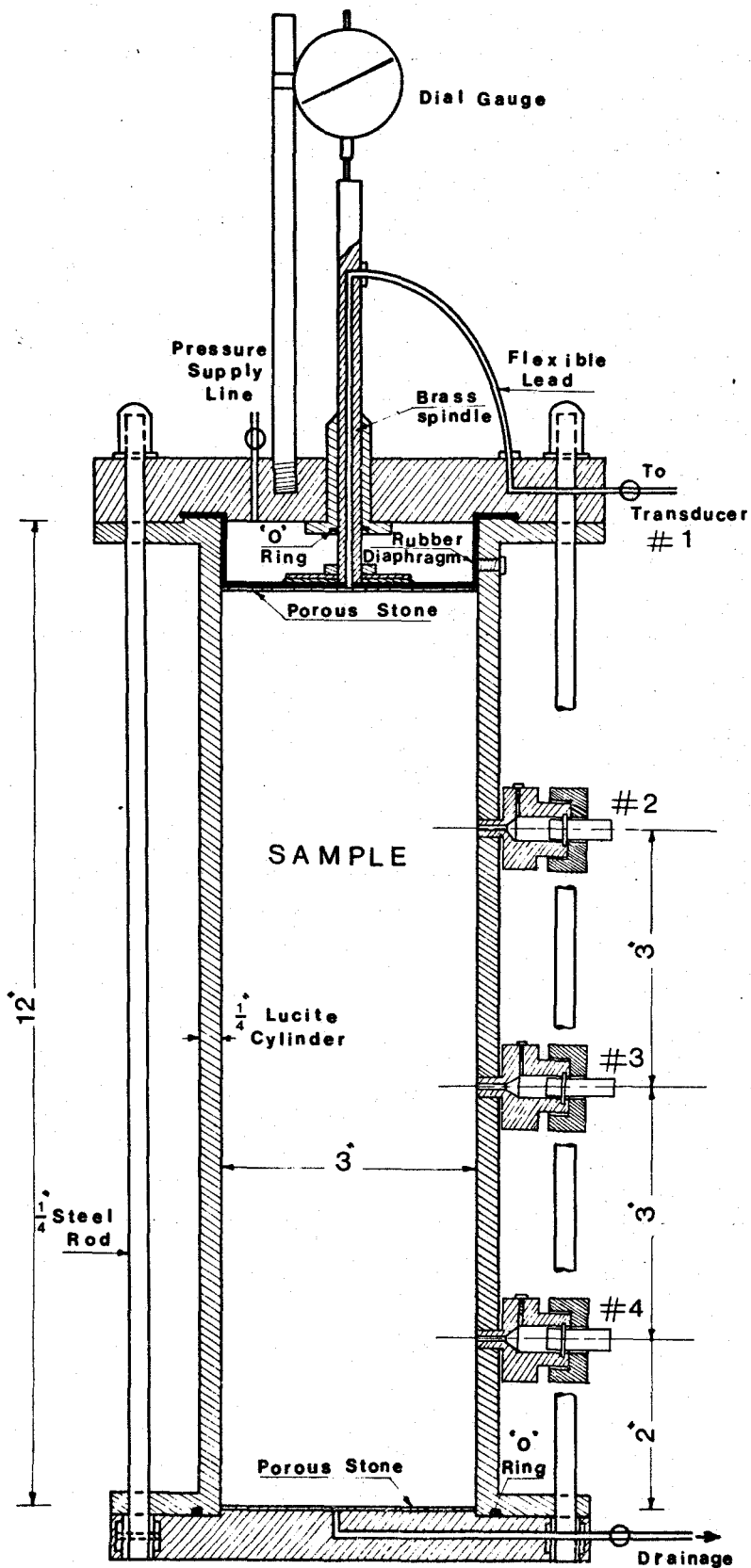

FIG.(11). THE CONSOLIDOMETER

The housing of the spindle in the cover contains an "O" ring which grips the spindle tightly to minimize the leakage, but not so tightly that the friction affects the settlement readings considerably.

The cylinder was tightened to the cover and the base by three screwed rods. An "O" ring provided the seal at the base, and the rubber diaphragm provided the seal at the cover.

B) Pressure Transducers: Pore water pressures and total pressures were measured using pressure transducers. A displacement of the diaphragm of the transducer occurs when the pressure is applied, the displacement changes the length of four strain gauges connected to the diaphragm and wired in the form of a Wheatstone Bridge. Any change in the lengths and consequently in the resistances of these gauges alters the electrical balance of the bridge.

The model number of the transducers used in the tests is PA-208-TC-25-350, from Statham Instruments Inc. California. A typical transducer housing is shown in fig. (12). The excitation voltages were fed to the transducers from Fylde D.C bridge amplifiers model number FE-392-BBS built by Fylde Electronic Laboratories, England. The power supplies were allowed to stabilize for one day before use. After this stabilizing time, the fluctuations in the excitation voltage observed were in

the order of 0.01 percent of the correct setting and were therefore insignificant. The signals from the transducers were passed through the bridge amplifiers to a Digital Voltmeter and recorded on a Digital Recorder, both manufactured by Hewlett Packard, California. Direct readings of the pressures in lb./sq.in. were obtained by choosing the appropriate value of the excitation voltages.

FIG. (12). TRANSDUCER HOUSING

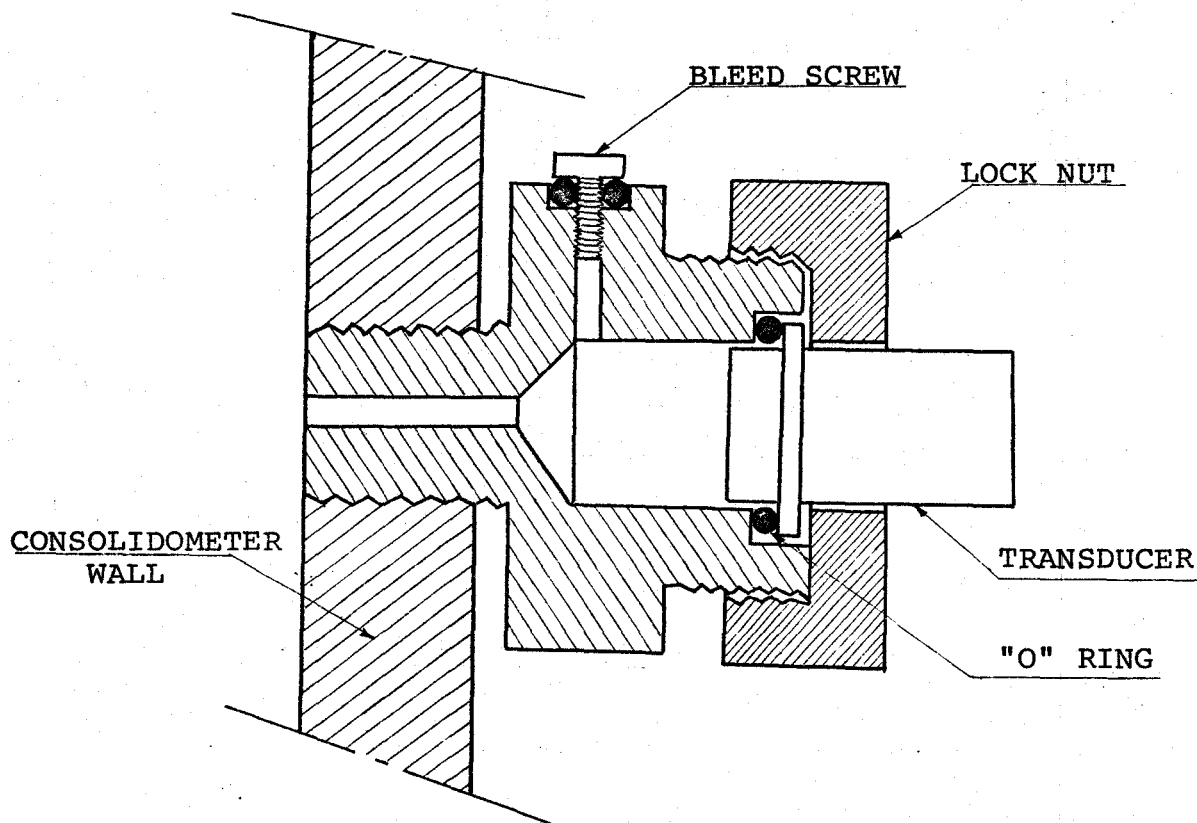

Preparation of the samples

The samples used were prepared from Kaolin powder (Hydrite U.F.), mixed with distilled water. This Kaolin has a uniform gradation; it is a fine silt with 8% clay sizes. The Atterberg limits changed depending on the time after mixing with distilled water; this was an indication that the Kaolin required a certain time to stabilize. Therefore, the Kaolin powder was mixed with distilled de-aired water in the consolidometer at a water content of approximately 200%, then the mixture was allowed to stand for one week to stabilize.

Before the cyclic loadings were applied to the samples, they were consolidated under a certain pressure. The purpose of this step was to duplicate the field condition, and to obtain samples as homogeneous as possible.

Testing procedure

After the samples had been prepared, certain precautions were taken to prevent the existence of air bubbles in the system. The trapped air in the transducer housing, was released using a bleed screw placed in the housing. The air trapped between the upper porous stone and the loading diaphragm was released using a bleed screw in the consolidometer wall.

All the tubing connections were flushed with

distilled de-aired water before connecting. Prior to starting the tests, all the lines and valves were checked for leaks and the presence of air bubbles.

A preliminary experimental check indicated that, with no drainage allowed, increases in the applied pressures produced an equal increase in the pore water pressures, indicating that the sample and the apparatus were 100% saturated.

The duration, frequency and magnitude of the pressure were changed for different tests. The laboratory temperature during the tests was $24 \pm 1^\circ\text{C}$, however the change during any test was very small since the duration of the tests was short, and the correction for the temperature effect would be very small (Yong and Warkentin 1966).

General

It was originally intended that organic soils would be used in preparing the samples for the tests. Many problems have arisen in the tests in which these samples were used due to the difficulties encountered in attempting to obtain an acceptable degree of saturation. The results of these tests were considered not to be reliable.

CHAPTER VI

EXPERIMENTAL RESULTS

The test procedure previously described was used on a total of seven tests; a summary of these tests is given in Table B. Pressure measurements were taken during the consolidation process; the pore water pressures at transducers #1, #2, #3 and #4, and the applied pressure was measured by a separate transducer. Settlement readings at the top of the samples were obtained.

Pore water pressures versus time relationship

Data from a typical cyclic loading test are shown in Fig. (13). Curves of the pore water pressure dissipation at different levels in the samples are shown in Figs. (14) and (15). The first application of the pressure produces the maximum value of the excess pore water pressure. The maximum value of the excess pore water pressure is almost equal to the maximum value given by the theory which is the value of the applied pressure. It can be seen from Figs. (14) and (15) that the maximum value of the excess pore water pressure decreases with depth. This can be attributed to the effect of the side friction resistance which decreases the value of the applied pressure with depth; this effect of the side friction resistance has been studied by Taylor (1942), Leonards and Girault (1961) and Lambe (1962). The effect of the side

friction resistance can be minimized by decreasing the ratio of the sample depth to the diameter.

As the pore water pressures are developed, the soil adjacent to the drainage boundary starts to consolidate under the cyclic pressure, while the soil remote from the drainage boundary has not yet started to consolidate. The dissipation of the excess pore water pressure starts at the transducer closest to the drainage boundary (#4) and progresses to the other transducers #3, #2 and #1 respectively.

Upon removal of the pressure, there are residual positive pore water pressures still existing in the soil. The existence of these residual pore water pressures can be attributed to the hydrodynamic time lag involved in the process of pore water pressure dissipation. Tests by Bishop and Henkel (1953) on normally consolidated undrained triaxial specimens showed that immediately after applying and releasing a stress there are usually residual pore water pressures which may be greater or less than the equilibrium pore water pressures in the soil. Successive cycles of loading and unloading and dissipation of the pore water pressures reduce the magnitude of the residual pore water pressures; this was also found by Knight and Blight (1965).

As the pore water pressures dissipate and the soil experiences increases in the effective stress,

negative pore water pressures are developed by unloading, this was also found by Skempton and Sowa (1963). As consolidation proceeds, the positive pore water pressures during loaded periods decrease resulting in increases in the effective stress and, consequently, resulting in increases in the negative pore water pressures during the unloaded periods. The rate of dissipation of the positive pore water pressures during loaded periods is approximately the same as the rate of development of the negative pore water pressures during unloaded periods. Eventually, the soil reaches a state in which further cycles of loading and unloading do not produce any appreciable change in the pore water pressure pattern.

Settlement versus time relationship

Typical curves for the settlement readings (during loaded periods and unloaded periods) versus time for a consolidating sample are shown in Fig.(16). The dissipation of the positive pore water pressures during loaded periods causes settlement to occur according to the effective stress principle. The settlements increase with the increase in the number of loading cycles. During the unloaded periods the soil rebounds; the amount of rebound remains approximately constant during the consolidation process. Eventually, after the pore water pressures reach the equilibrium condition, the soil acts

completely elastic and the curve of the settlement reading versus time becomes asymptotic to a minimum value. Settlement readings versus time curves for three tests consolidated under the same cyclic loading pattern are shown in fig. (17). It can be seen that, for the three tests the settlements reach the equilibrium state at approximately the same time.

The consolidation ratio versus time and depth

By extrapolating the data obtained from transducers #1, #2, #3 and #4, the consolidation ratio during the consolidation process is obtained. The curves of the consolidation ratio versus time and depth are shown in Figs. (18) and (19), the experimental curves are shown as dotted lines and the theoretical curves as full lines. Examining the experimental curves, we can see that the consolidation ratio at a certain depth increases with time (i.e the increase of the number of load cycles), until finally the increase in the consolidation ratio becomes very small and the consolidation ratio reaches a maximum value under that particular cyclic loading pattern. Comparing the experimental curves with the theoretical curves, we can see that there is reasonable agreement between them; it can also be seen that the theoretical consolidation is slower than the consolidation found from experimental data.

Some discrepancies between the experiment and the

theory have arisen in the test on a very soft sample (Test #T5). Fig. (19) shows that the experimental consolidation ratio is greater than the theoretical consolidation ratio, which may be due to the fact that, for the soft sample, the coefficient of consolidation is greater than the coefficient of swelling. The better agreement between the experimental and the theoretical curves in the case of Test #T4 (fig. (18)) can be attributed to the higher preconsolidation pressure of this sample which makes the coefficient of consolidation and the coefficient of swelling approach the same value.

The relation between the equilibrium consolidation ratio and the cycle ratio (T_1/T) for all the tests is shown in fig. (20). It can be seen that a linear relationship exists between the equilibrium consolidation ratio and the cycle ratio (T_1/T).

Comparison between the consolidation due to cyclic and sustained loading

It is possible to make a direct comparison between the consolidation due to cyclic loading and due to sustained loading by considering the consolidation ratio for the summation of the time when the load is applied to the sample. A comparison between the progress of consolidation due to cyclic loading for Test #T4 and the theoretical process of consolidation due to a sustained load is shown in fig. (21); the curves for the cyclic

loading show the elapsed time of the consolidation process and the summation of the time of load application only. During the early stages of the process, the consolidation due to the sustained load proceeds more rapidly than the consolidation due to the cyclic load in the upper part of the sample; while in the lower part of the sample, the consolidation due to the cyclic load proceeds more rapidly. However, in the later stages of the process, the consolidation due to the sustained load proceeds more rapidly than the consolidation due to cyclic load in the upper and lower parts of the sample. It can also be seen that the final consolidation ratio due to the sustained load is 1.00, but the equilibrium consolidation ratio due to the cyclic load is a function of the cyclic load pattern.

TABLE A

Basic Properties of Kaolin

Atterberg Limits

Liquid Limit	71
Plastic Limit	40
Plasticity Index	31

Grain Size Analysis

D_{60}	=	0.0066"
D_{10}	=	0.0022"
Coefficient of Uniformity	=	3
Specific Gravity	=	2.6
Coefficient of Consolidation	=	$1.72 \times 10^{-2} \text{ cm}^2/\text{Sec.}$
(load increment 1.0 psi to 10.0 psi)		

TABLE B

Summary of the Tests

<u>TEST NO.</u>	<u>PRECONSOLIDATION</u>	<u>CYCLIC</u>	<u>LOAD CYCLE</u>	
	<u>PRESSURE</u>	<u>PRESSURE</u>	<u>T1</u> (min)	<u>T</u>
	p.s.i.	p.s.i.		
T1	1.09	3.57	0.75	1.0
T2	4.66	5.23	0.75	1.0
T3	1.23	2.26	0.75	1.0
T4	9.63	3.12	0.75	1.0
T5	0.98	2.63	1.25	1.5
T6	3.61	3.91	1.00	2.0
T7	7.52	5.14	1.25	2.0

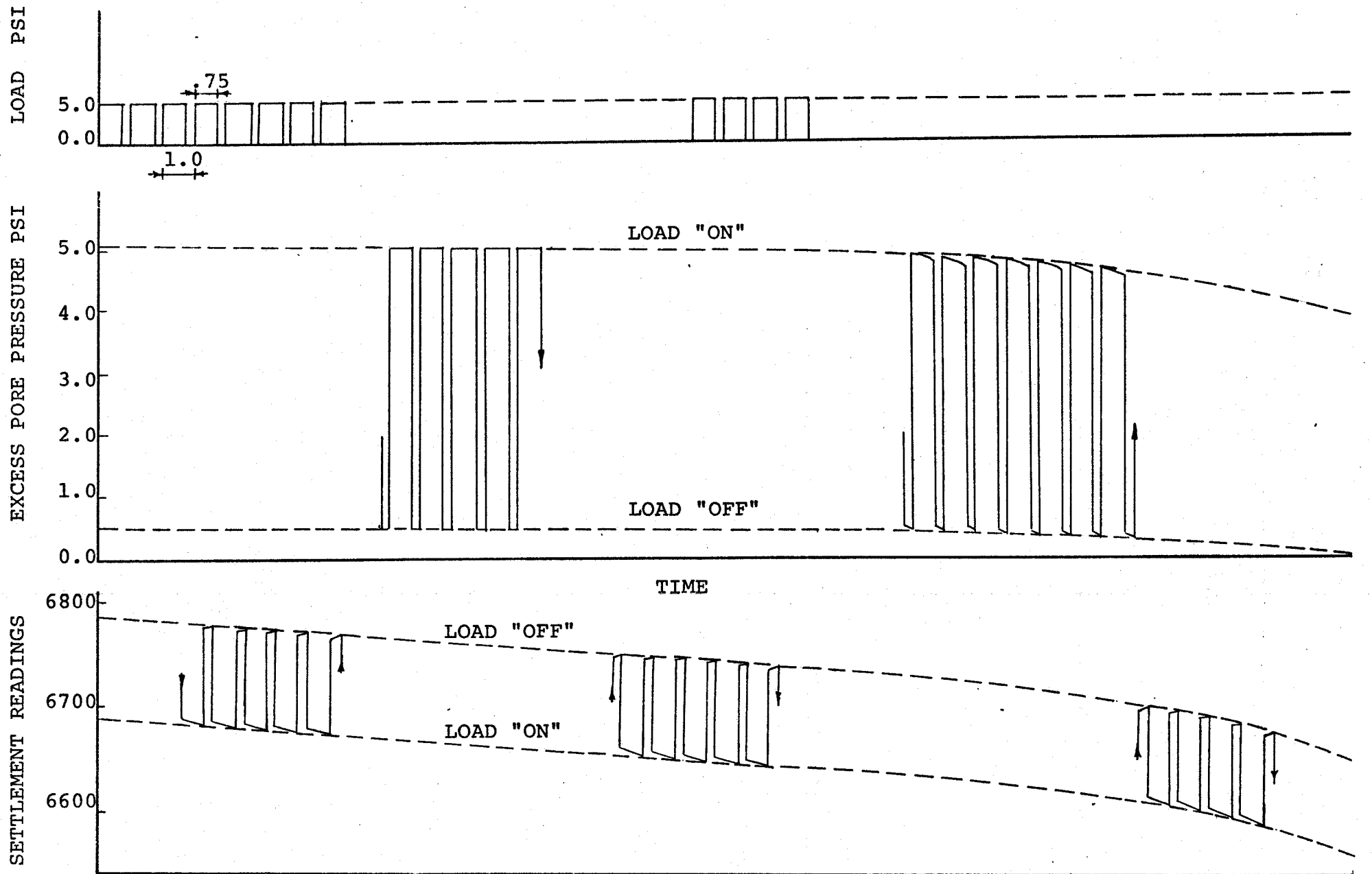

FIG. (13). TYPICAL CURVES OF LOAD, EXCESS PORE PRESSURE, SETTLEMENT READINGS VERSUS TIME.

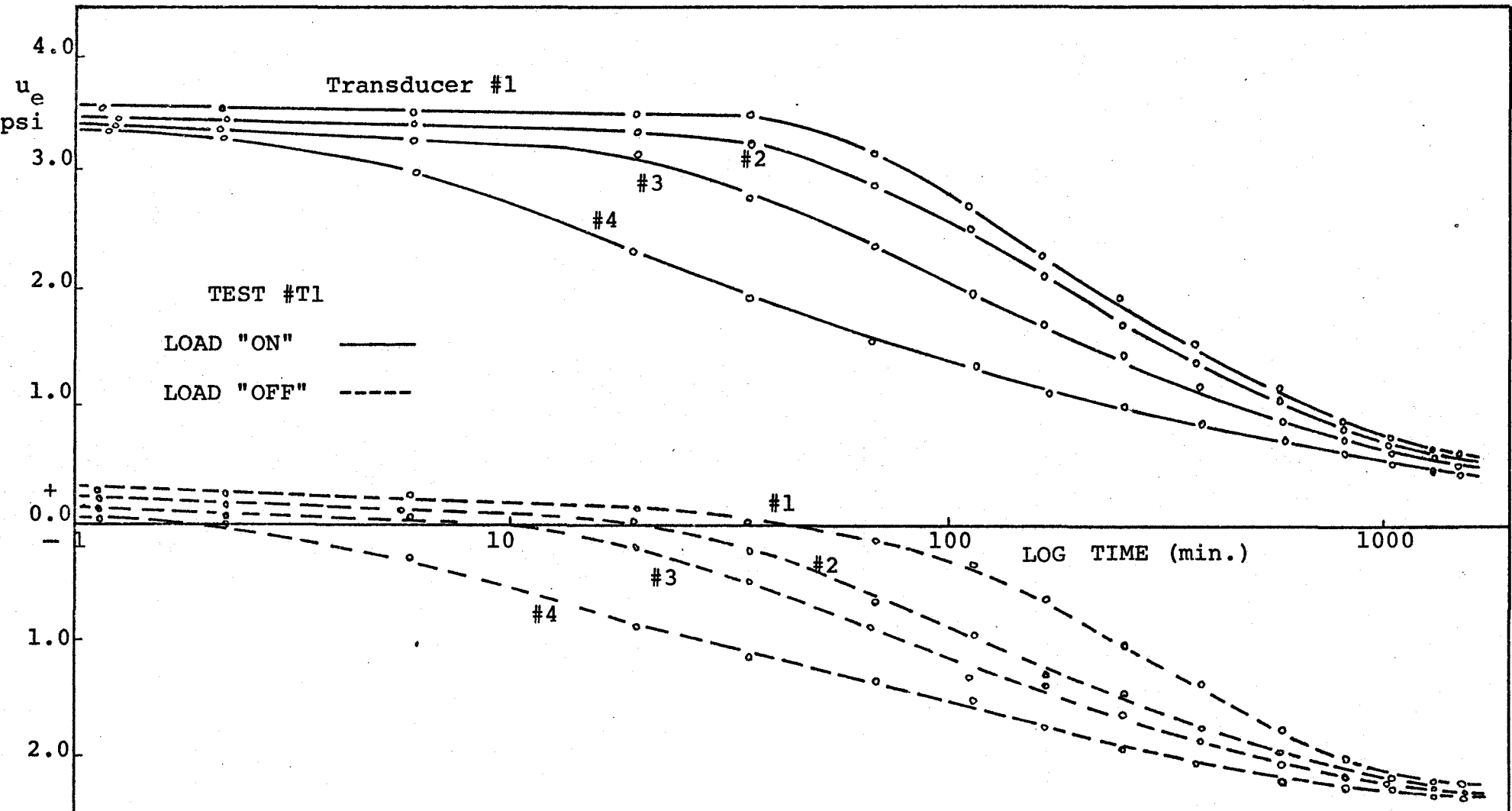

FIG. (14). EXCESS PORE WATER PRESSURE VERSUS TIME.

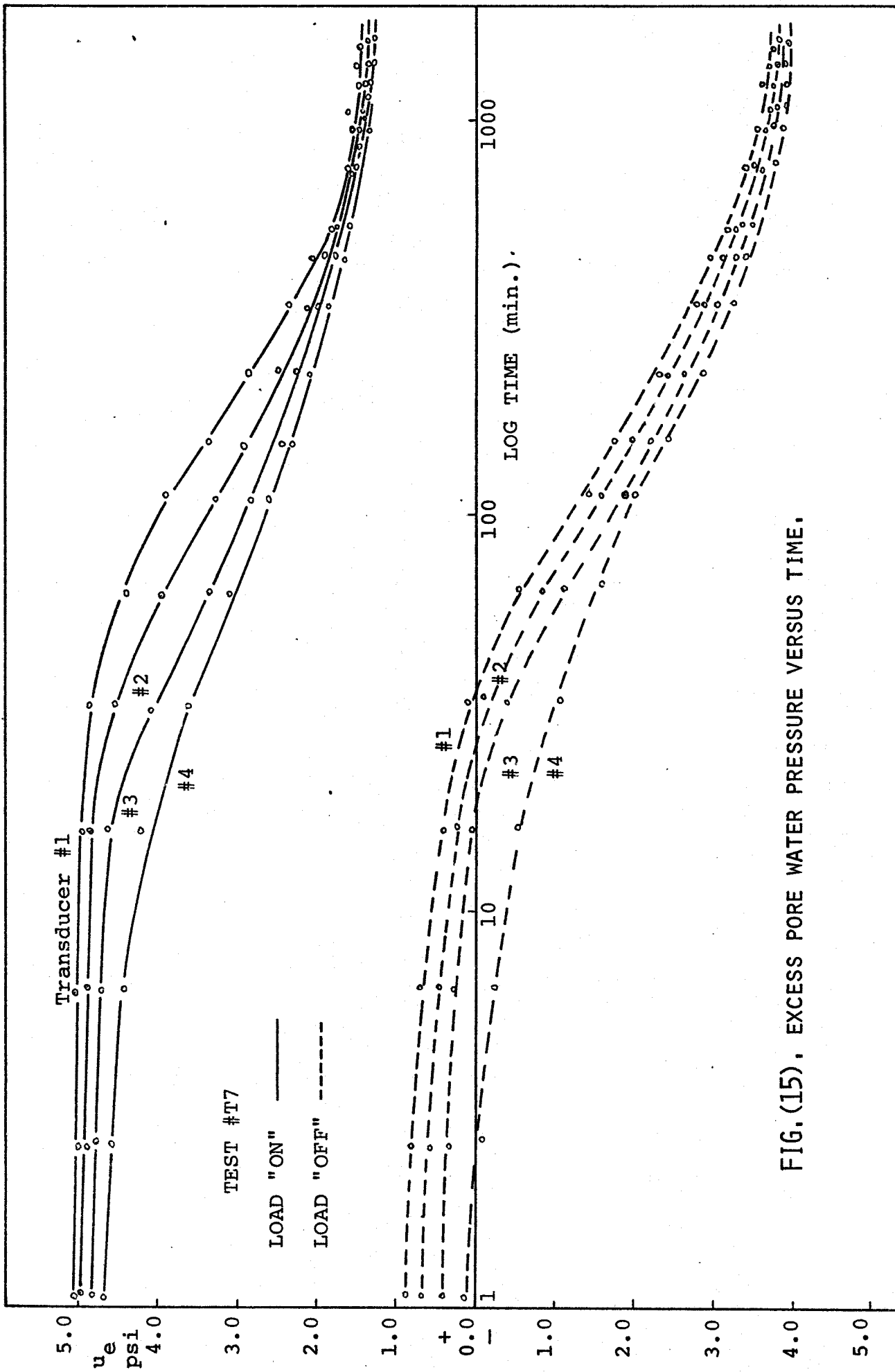
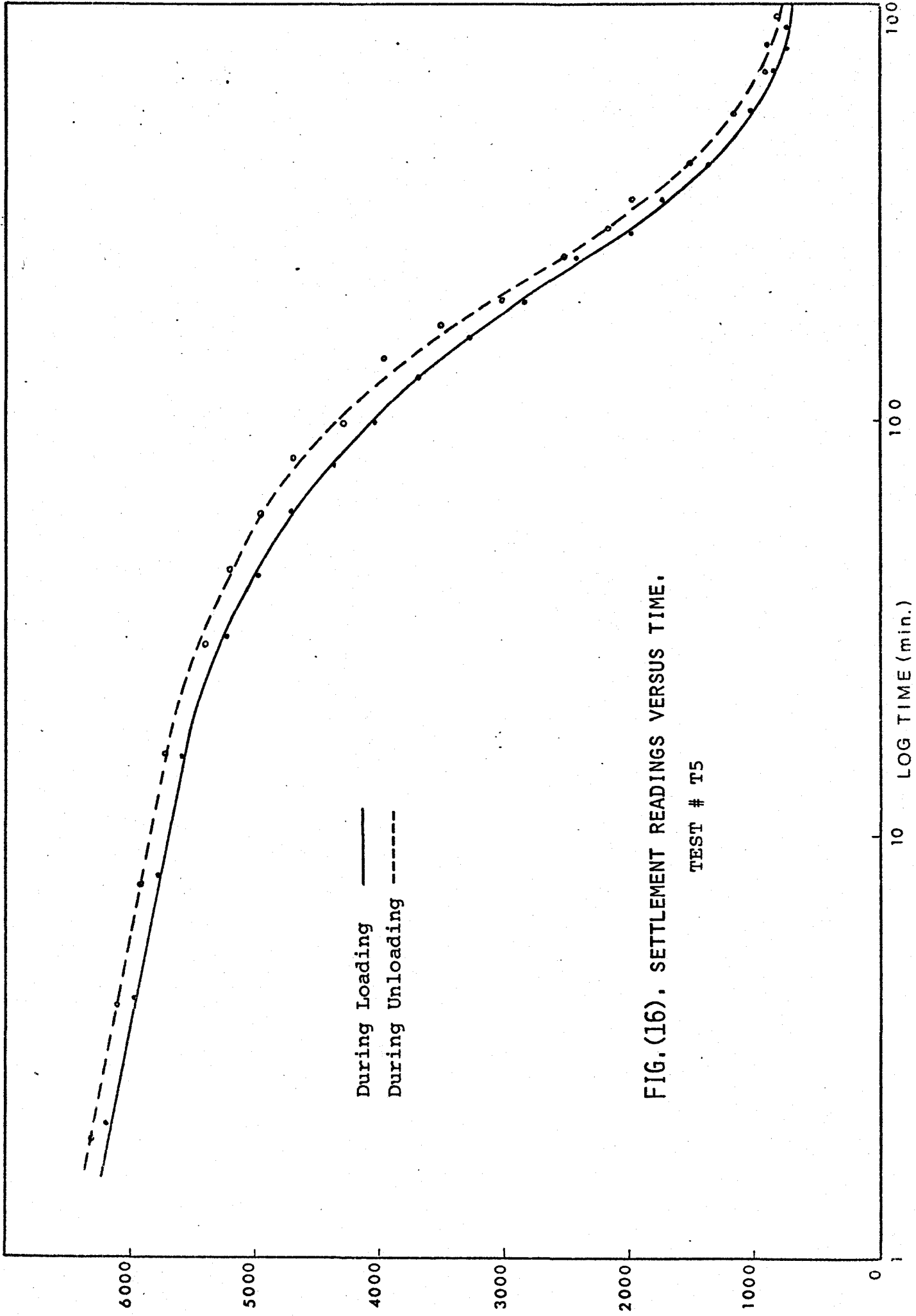
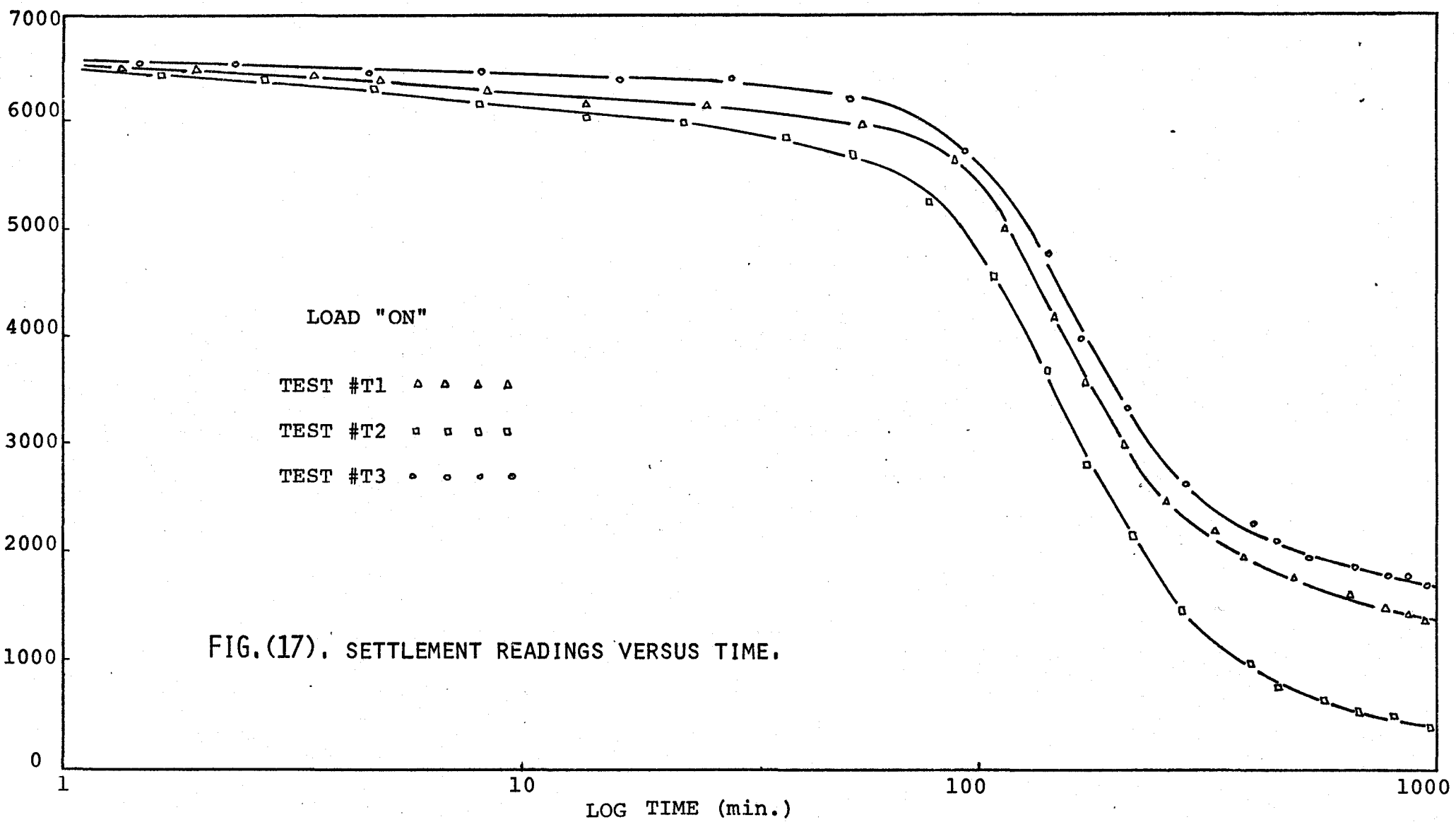

FIG. (15), EXCESS PORE WATER PRESSURE VERSUS TIME.



During Loading —
During Unloading - - - -

FIG. (16). SETTLEMENT READINGS VERSUS TIME.
TEST # T5



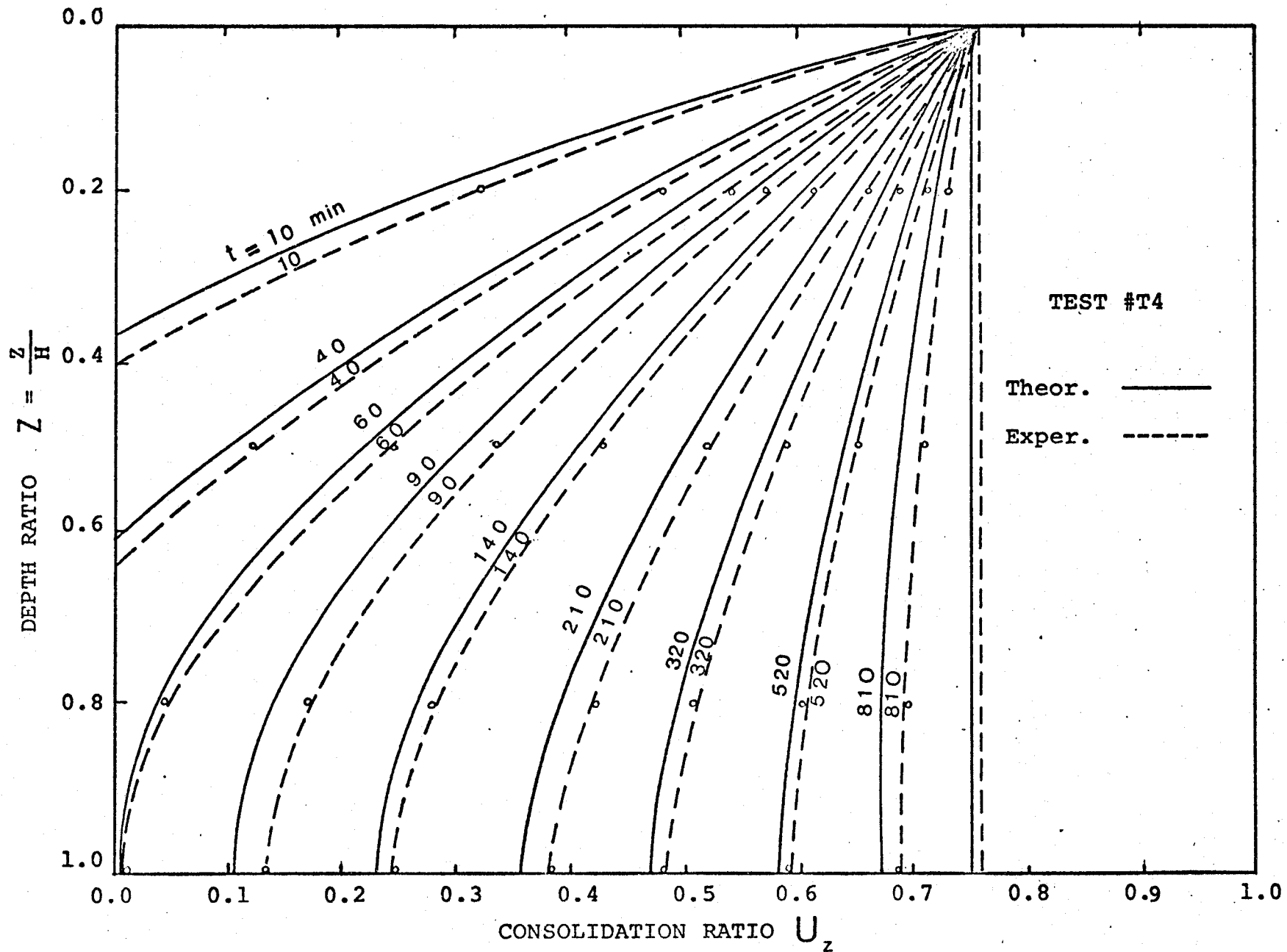

FIG. (18). CONSOLIDATION RATIO AS A FUNCTION OF DEPTH AND ELAPSED TIME.

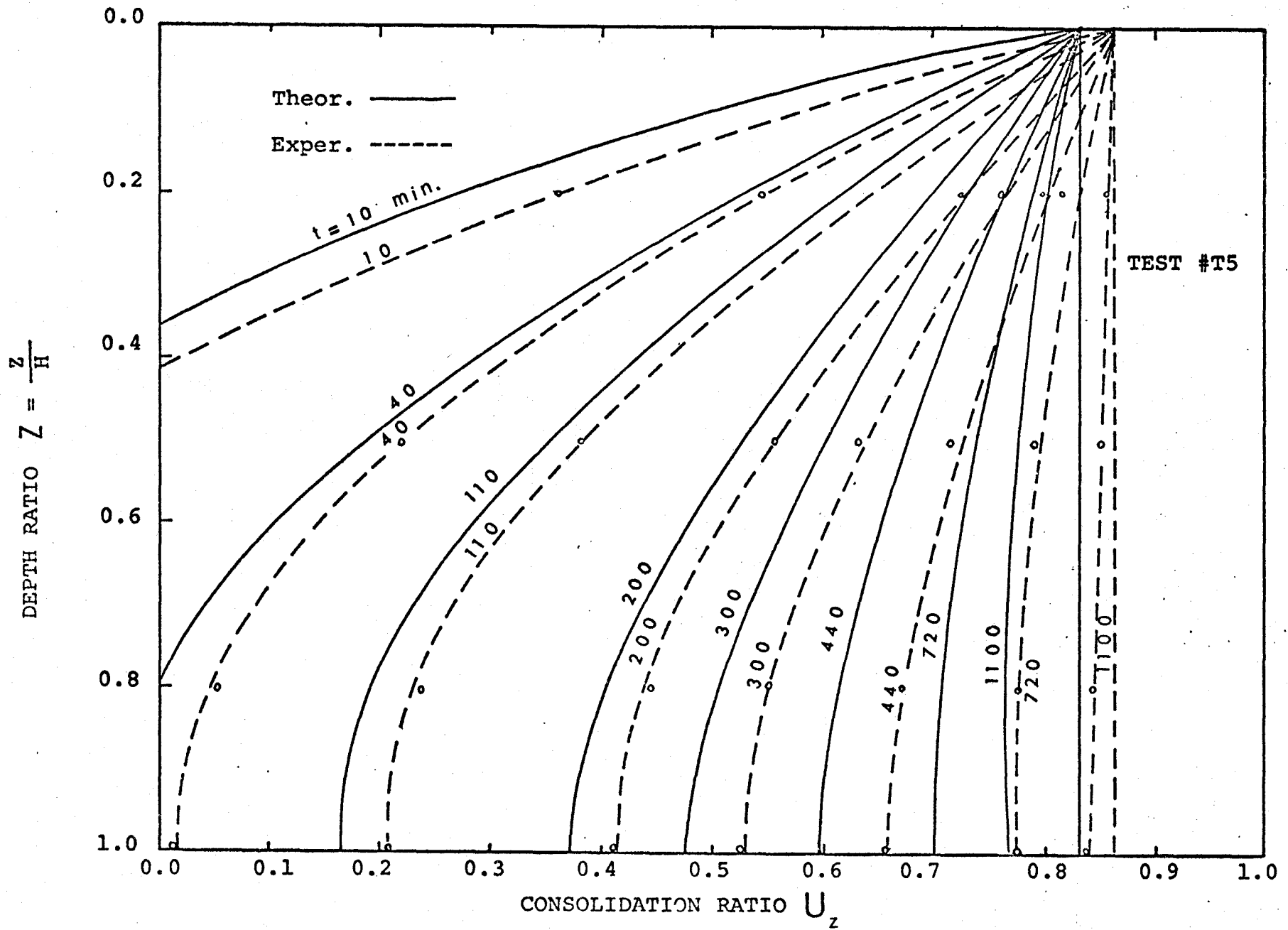

FIG. (19). CONSOLIDATION RATIO AS A FUNCTION OF DEPTH AND ELAPSED TIME.

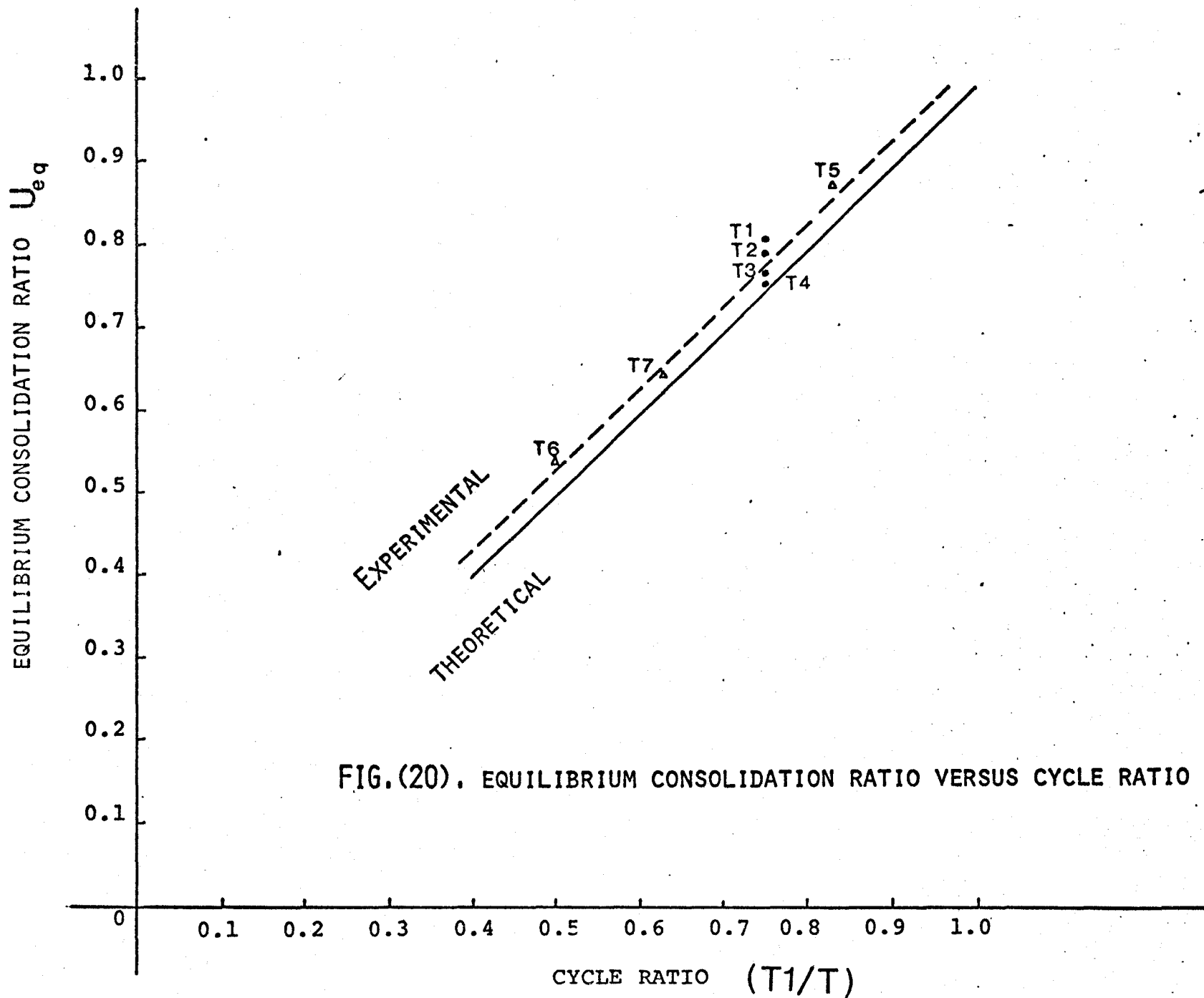

FIG.(20). EQUILIBRIUM CONSOLIDATION RATIO VERSUS CYCLE RATIO

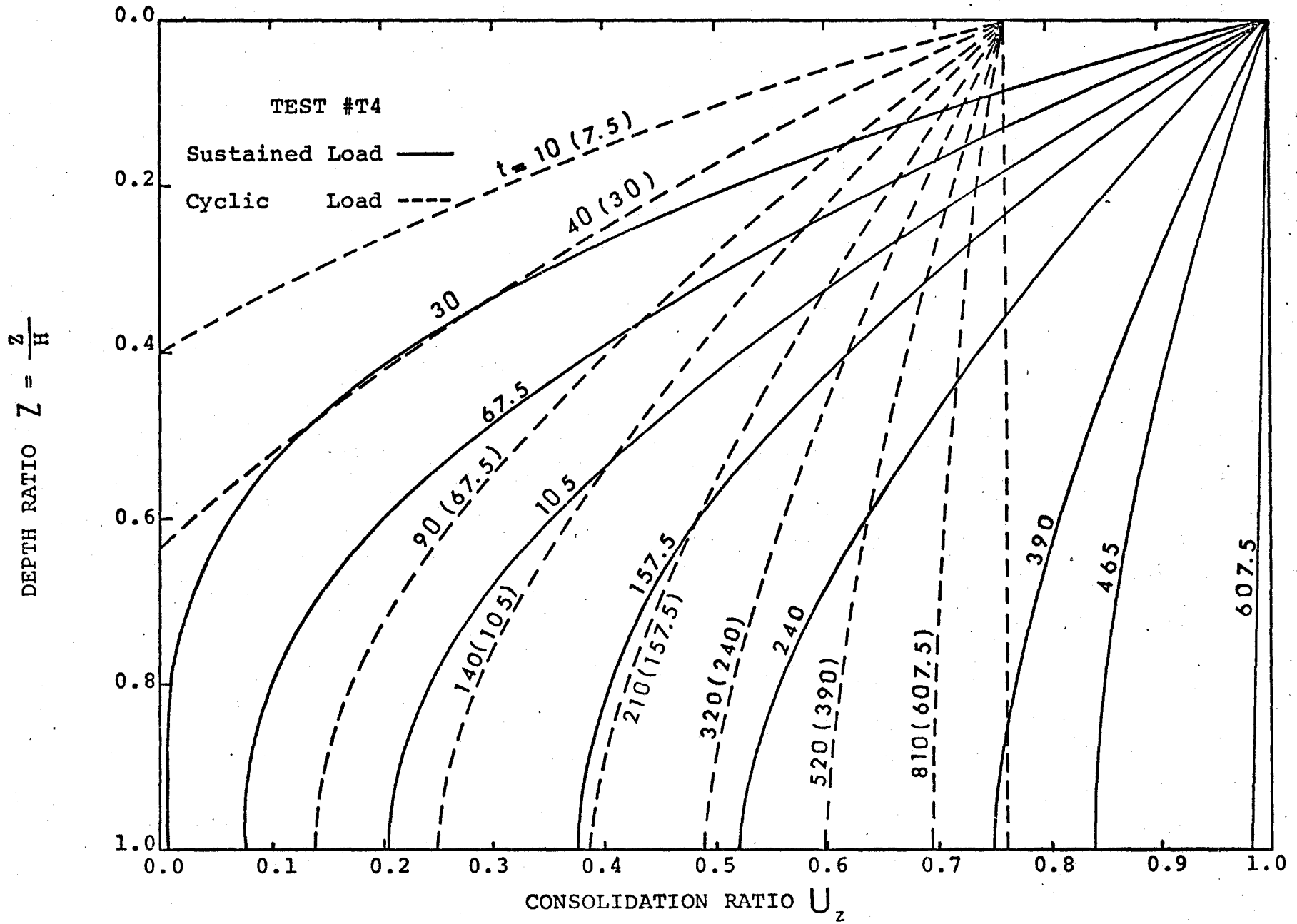

FIG. (21). COMPARISON BETWEEN CYCLIC AND SUSTAINED LOADING.

CHAPTER VII

CONCLUSIONS AND RECOMMENDATIONS

Conclusions

Terzaghi (1925) developed the theory of the one dimensional consolidation of soils. This theory does not consider cases of consolidation under cyclic loading. In this research work, the equations governing the process of the one dimensional consolidation of a saturated soil layer subjected to cyclic loading are derived in a form sufficiently general for most practical applications, using the fundamental equation of consolidation.

The equations governing the process show that, when a soil layer is subjected to cyclic loading, positive pore water pressures are developed when the soil is loaded, and negative pore water pressures are developed when the soil is unloaded. As cycles of loading and unloading continue, the positive pore water pressures decrease and the negative pore water pressures increase. Eventually, the soil reaches a steady state condition in which the positive and negative pore water pressures have final equilibrium values.

In the steady state conditions, the equilibrium consolidation ratio is a function of the cyclic loading pattern, and it is always less than 1.00 . This means

that only a part of the applied pressure is transferred to the soil particles, and the rest of the applied pressure is still carried by the excess pore water pressure. At this stage the soil acts completely elastic, and the settlement reaches its maximum value.

The progress of consolidation due to a sustained load proceeds more rapidly than the consolidation due to a cyclic load. This is due to the swelling that takes place during the periods in which the soil is unloaded under the cyclic loading. Thus the soil increases in strength when consolidated under a sustained loading more rapidly than when consolidated under cyclic loading.

Recommendations

The solution to the problem of consolidation under cyclic loading in terms of linear parameters has been necessary because an exact mathematical solution is then possible. For solutions to be of any practical use, they must involve a minimum of parameters, and not be too complicated for general use. However, it would be of interest to investigate a nonlinear treatment of the problem involving the minimum number of parameters necessary to describe the basic nonlinear nature of the process, and try to produce sufficiently accurate numerical solutions for practical use.

The composition and structure of soils vary widely due to difference in their formations and stress history. Therefore, determination of the consolidation characteristics of a wide range of soils is necessary to determine the applicability of this approach for different types of soils. This can be done by performing a large number of tests with a variety of soil types and cyclic loading patterns.

REFERENCES

- BISHOP, A.W. and HENKEL, D.J. (1953). "Pore Pressure Changes During Shear in two Undisturbed Clays". Proc. 3rd Int. Conf. SM&FE, Vol. I, p 94.
- CARSLAW, H.S. and JAEGER, J.C. (1956). "Conduction of Heat in Solids". Oxford.
- CHRISTIE, I.F. (1965). "Secondary Compression Effects During One-dimensional Consolidation". Proc. 6th Int. Conf. SM&FE, Vol. I, p 198.
- GIBSON, R.E. (1958). "The Progress of Consolidation in a Clay Layer Increasing in Thickness with Time". Geotechnique, Vol.VIII, p 171.
- HENKEL, D.J. (1960). "The Relationship between the Effective Stresses and Water Content in Saturated Clays". Geotechnique, Vol.X, p 41.
- ISHII, Y. (1951). "General Discussion, Symposium on Consolidation Testing of Soils". ASTM, STP 126, p 103.
- KNIGHT, K. and BLIGHT, G.E. (1965). "Studies of Some Effects Resulting from Unloading of Soils". Proc. 6th Int. Conf. SM&FE, Vol.II, p 103.
- LAMBE, T.W. and WHITMAN, R.V. (1969). "Soil Mechanics". John Wiley, New York.

LAMBE, T.W. (1962). "Soil Testing for Engineers".

John Wiley, New York.

LEONARDS, G.A. and GIRAULT, P. (1961). "A Study of the One-dimensional Consolidation Test". Proc. 5th Int. Conf. SM&FE, Vol. I, p 213.

LO, K. Y. (1961). "Stress-Strain Relationship and Pore Pressure Characteristics of a Normally Consolidated Clay". Proc. 5th Int. Conf. SM&FE, Vol. I, p 219.

NORTHEY, R.D. and THOMAS, R.E. (1965). "Consolidation Test Pore Pressures". Proc. 6th Int. Conf. SM&FE, Vol. I, p 323.

PERLOFF, W.H. and NAIR, K. and SMITH, J.G. (1965). "Effect of Measuring System on Pore Water Pressures in the Consolidation Test". Proc. 6th Int. Conf. SM&FE, Vol. I, p 338.

ROWE, A.W. and BARDEN, L. (1966). "A New Consolidation Cell". Geotechnique, Vol. XVI, p 162.

SCHIFFMAN, R.L. (1958). "Consolidation of Soil under Time Dependent Loading and Varying Permeability". Proc. Highway Research Board, Vol. XXXVII, p 584.

SKEMPTON, A. W. (1954). "The Pore Pressure Coefficients A and B." Geotechnique, Vol. IV, p 143.

SKEMPTON, A.W. and SOWA, V.A. (1963). "The Behaviour of Saturated Clays During Sampling and Testing". Geotechnique, Vol. XIII, p 269.

TAYLOR, D.W. (1942). "Research on Consolidation of Clays".

Publ. Serial 82, Dept. of Civil Eng., M.I.T.

————— (1948). "Fundamentals of Soil Mechanics".

John Wiley, New York.

TERZAGHI, K. (1925). "Erdbaumechanik auf Bodenphysikalischer Grundlage". Deuticke. Vienna.

————— and FROHLICH, O.K. (1936). "Theorie der Setzung von Tonschichten". Deuticke. Vienna.

————— (1943). "Theoretical Soil Mechanics".

John Wiley, New York.

WAGENER, F. (1960). "Consolidation Settlement of Soils under Repetitive Loading as Experienced in Road Foundations".

M.Sc. (Eng.), Thesis, University of the Witwatersrand

YONG, R.N. and WARKENTIN, B.P. (1966). "Introduction to Soil Behaviour". Macmillan, New York.

APPENDIX A

SYMBOLS

English

a	= Area of soil element.
$a_{vc} = a_v$	= Coefficient of Compressibility.
$a_{ve} = a_v$	= Coefficient of Expansion.
C_{vc}	= Coefficient of Consolidation. $= \frac{k(1+e)}{\gamma_w \cdot a_{vc}}$
C_{vs}	= Coefficient of Swelling. $= \frac{k(1+e)}{\gamma_w \cdot a_{ve}}$
e	= Void ratio of the soil.
h	= Total head.
h_e	= Elevation head.
H	= Initial thickness of the soil stratum.
i	= Hydraulic gradient.
i	= Index.
k	= Coefficient of Permeability.
$k_m = k(\lambda_m, z)$	= Transform Kernel.
m	= Summation index.
M	= $\frac{(2m+1)\pi}{2}$
n	= Normal to the boundary surface.

$P=P(z,t)$	= Effective Pressure.
P	= Applied Pressure.
P_t	= Total Pressure.
$\bar{P}(\lambda_m, t)$	= Integral Transform.
q	= Flow of water in unit time
r	= Index.
S	= Degree of Saturation.
$t = t'$	= Time.
t_1	= Time during "ON" period.
t_2	= Time during "OFF" period.
T	= Length of Load Cycles.
T_1	= Duration of Load Application.
$T-T_1$	= Interval between Load Application.
T_1/T	= Cycle ratio.
$u=u(z,t)$	= Pore water Pressure.
u_e	= Excess Pore Water Pressure.
u_{ss}	= Steady State Pore Water Pressure.
U_z	= Consolidation Ratio.
U_{av}	= Average Consolidation Ratio.
V_w	= Volume of Water.
z	= Depth.
$Z = \frac{z}{H}$	= Depth Ratio.

Greek

α_m	= $C_v M^2 / H^2$
γ_w	= Unit Weight of Water.
λ_m	= The Eigenvalues.
Σ	= Sum.
$\phi(t)$	= Loading Function.
$\Psi(z)$	= Auxiliary Function.