

## Consumer Ethnocentricity within the Environment of Economic Crisis

Zuzana Kreckova<sup>1</sup>, Jitka Odehnalova<sup>1</sup>, James Reardon<sup>2</sup>

<sup>1</sup>Faculty of International Relations, University of Economics  
Winston Churchill Sq. 4, 130 67 Prague, Czech Republic  
e-mail: zuzana.kreckova@vse.cz, jitka.odehnalova@vse.cz

<sup>2</sup>Monfort College of Business, University of Northern Colorado  
Campus Box 128, Greeley, CO 80620, USA  
e-mail: james.reardon@unco.edu

**crossref** <http://dx.doi.org/10.5755/j01.ee.23.3.1932>

*The purpose of this study is to examine consumer tendencies within the economic crisis, to examine consumer ethnocentrism (CE) among CEE consumers and its character and influence on buying domestic and foreign products. Based on broad existing theoretical and empirical knowledge, we constructed measures for this research derived from existing literature. The hypotheses were tested through structural equation modeling. The analyzed sample consisted of 199 Czech respondents. The results confirm effect of CE on buying behavior as well as national identity influence on CE. In the Czech context, CE significantly and positively influenced domestic purchase behavior. Alternatively, there was only a marginal influence of CE supported its negative effect on foreign purchase behavior. Cosmopolitanism did not affect CE in the Czech context. Therefore, the research findings suggest a prevalent influence of CE on buying behavior under conditions of economic crisis. The paper concentrates on ignored area that was very hard hit by economic crisis in Central and Eastern Europe. The findings provide useful information to marketing specialists in designing their marketing strategies for local “made-in” communication campaigns. In addition, implications for retailers to evaluate their merchandise assortment portfolio are implied from the findings. We build on the positive influence of CE on buying behavior of domestic products versus foreign, and infer preference for freshness and quality of goods. This suggest implications for public policy implications related to local job creation and employment, especially within the area of small local producers, self-employment, development of local agriculture, as well as countryside maintenance. This issue seems to gain more importance and attention given the nature of the global economic crisis for consumers, producers, retailers and government. Potentially, there appears to be significant carryover effect related to the present and future integration processes of the CEE economies.*

**Keywords:** *ethnocentricity, cosmopolitanism, national identity, consumer behavior, country-of-origin, Czech consumer.*

### Introduction

Pre independence, the supply of goods was extremely limited in CEE as a result of centrally planned economies. Hence, after the fall of the Iron Curtain in 1989, consumers had enormous passion for foreign products, and their buying was supported by high quality marketing campaigns of foreign companies which were developed and honed in highly competitive environment of market economies. From the perspective of two decades later, most CEE producers, retailers, and other players, as well as consumers have begun to approach parity with western counterparts. Thus, a shift back to focusing on local products has occurred. This combined with a global economic recession, has refocused the continuing debate related to the implications for concentrating on the manufacture, distribution and purchase of domestic versus foreign goods.

*The importance of examining ethnocentricity is highlighted given the recent economic crisis, affecting especially small open economies thanks their intensive international integration and dependence.* Particularly in the EU single market, all players must focus on finding the most efficient ways to satisfy consumer needs. While public policy officials drive forward the conversation related to local versus foreign good consumption, in the end, it is the

consumer who drives the behavior and thus the market. For this reason, it is essential to concentrate on the consumer decision process. To some extent, this process is well defined in the current literature. *Thus this research focuses on this process as it related to the existing constructs of national identity, ethnocentrism and cosmopolitanism reflected in consumer behavior.*

Trends, tendencies, and practical consumer behavior suggest that many CEE consumers prefer buying domestic goods, especially by food category (ČTK, 2011) as the perception of the quality of local food products increased by CEE customers. (ČTK, 2010a) This is also true for other specific goods, for example, “Czech customers are returning from foreign brands to Škoda cars.” (Autofox, 2010) Thus, *the question that remains is the degree to which these effects are inflated during the economic downturn and what affects this decision process.*

The findings provide insight into the phenomenon of ethnocentrism and examine its relative effect on buying behavior of domestic versus foreign products in smaller CEE countries during economic crisis. Smaller, transitional economies have been hungry for foreign goods during the last two decades; however with local producers approaching parity of quality, in addition to being hard hit during the

economic crisis, we expect significant changes in this model in such a unique environment.

The purpose of this study is to examine the Czech consumer tendencies within the economic crisis, to examine consumer ethnocentrism (CE) among Czech consumers and its character and influence on buying domestic and foreign products during economic crisis.

Based on broad existing theoretical and empirical knowledge, we constructed measures for this research derived from existing literature. The hypotheses were tested through structural equation modeling of 199 Czech respondents. The Czech Republic was chosen as somewhat representative of a smaller CEE transitional country that was significantly impacted by the global recession. The research limitations lie in the respondents sample consisting only of young consumers and single country analysis.

## Literature review

Marketing practitioners work with the fact that consumers tend to have a diverse perception of product based on the national images of the country of its origin or where it is believed to be produced. Decades of country-of-origin research proved evidence that these perceptions affect consumer attitudes, purchase intention and finally behavior. (Pharr, 2005; Laroche et al., 2005) Two streams of research developed over time. The first one focuses on consumer preferences regarding product from specific countries (i.e., country-image studies; Dmitrović, Vida, 2010; Roth, Diamantopoulos, 2009), the second stream of research focuses on factors that lead consumers to prefer either local (domestic) or foreign products (e.g., Vida et al., 2008; Sharma et al., 1995; Crawford, Lamb, 1982). This research focuses on the later stream of the research.

A decade ago, Mooij and Hofstede (2002) stated that increasing world globalization will not lead to product homogenization as a consequence of cultural differences. Such conclusion was contradictory to expectations of Theodore Levitt who anticipated that world globalization will be clearly reflected in product homogenization throughout the world economies (Levitt, 1983, p. 92-93). Hofstede's findings were further developed and proposed that the country-of-origin (COO) of products as the nationality of consumer goods stays important factor in consumer purchasing behavior (Al-Sulaiti, Baker, 1998; Peterson, Jolibert, 1995; Verlegh, Steenkamp, 1999). Other researchers (Douglas, Nijssen, 2004; Granzin, Olsen, 1998; Han, 1988; Shimp, Sharma, 1987) further added that in defined cases consumers tend to prefer domestic products to foreign ones. While other researchers suggest that the opposite is true under certain conditions (Good, Huddleston, 1995). It is those conditions and circumstances that are of interest to this research. *Additionally, Herche, Vida and Dmitrovic suggest that buying behavior changes patterns with significant political or economic changes. (Herche, 1994; Vida, Dmitrovic, 2001) The conjunction of these two situations presents a unique opportunity to examine these effects.*

The country-of-origin effect (COO), also known as the "made in" concept, has been broadly defined as the positive or negative influence that a product's country of manufacture may have on consumers' decision processes

or subsequent behavior (Elliott, Cameron, 1994). More broadly and recently, models of consumer ethnocentrism focus on the responsibility and morality of purchasing foreign-made products and the loyalty of consumers to products manufactured in foreign countries (Shimp, Sharma, 1987). However, most of the subsequent research has focused on the effect of CE on domestic goods.

## Conceptual development

***Ethnocentric Attitudes.*** Current research dealing with consumer ethnocentrism provides supporting theoretical framework for empirical. It represents an individual tendency to believe that it is disloyal to one's own country to buy foreign products, because it could cause a negative effect on the domestic economy. (Shimp, Sharma, 1987) Sharma, Shimp and Shin (Sharma et al., 1995) explain why and under what circumstances the consumer ethnocentrism develops. Their work contributed to the knowledge by creating a model for understanding the consumer ethnocentricity analyzing both the forming and the resulting.

Their aim was to "examine antecedents of consumer-ethnocentric tendencies and the impact these tendencies have on attitudes toward importing products. Regarding antecedent relationships, CE is shown to be positively correlated with collectivist tendencies and with patriotic/conservative attitudes but negatively correlated with cultural openness, education, and income. The relationship between ethnocentric tendencies and attitudes toward imports is moderated by product necessity and the extent of threat these products are perceived to have on the consumer personally and on the domestic economy more generally." (Sharma et al., 1995) The original visualization of the model as follows (Figure 1).

Among the forming factors of the Consumer Ethnocentrism, openness to foreign cultures, collectivism and individualism, patriotism, conservatism and consumer demographics belong. As important factors affecting the power of ethnocentrism, individual empirical studies (Herche, 1994; Kaynak, Cavusgil, 1983) show the level of perceived product necessity, product involvement and the extent to which foreign products symbolize a threat to both individual and economic prosperity.

Consumer ethnocentricity affects consumer preferences and behavior in general in economies at different stages of development (e.g., Batra et al., 2000; Dinnie, 2004; Sharma et al., 1995). Recently developing countries and emerging economies were of interest of scientists - India (Bawa, 2004; Khan, Rizvi, 2008), Baltic states (Parts, 2007), Turkey (Dedeoglu et al., 2005), Slovenia (Vida, Damjan, 2000), Poland (Cumberland et al., 2010), Russia (Puzakova et al., 2010), and China (Hsu, Nien, 2008).

The specificity of effects within various economies depends on various market situation, mentioning especially the stage of economic development, market competition and general economic situation. An important role is being played by the availability of alternative products, as well as specific consumer values and characteristics. (Balabanis et al., 2001; Reardon et al., 2005; Shankarmahesh, 2006; Yelkur et al., 2006; Wang, Chen, 2004).

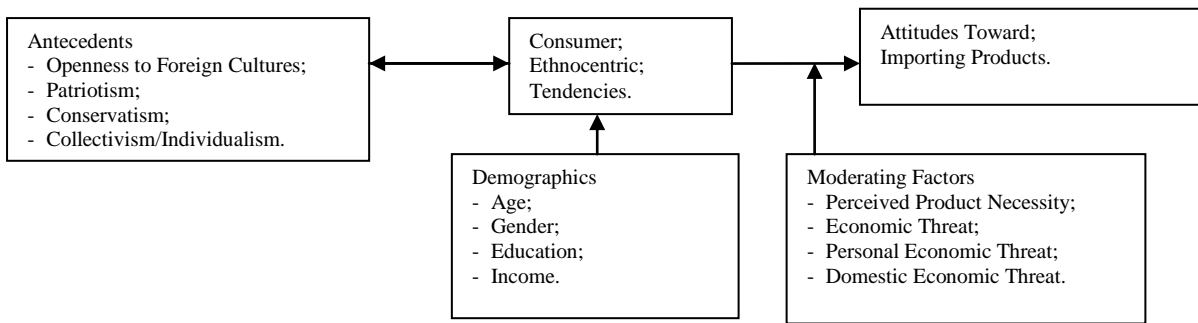

Figure 1. Conceptual Model (Sharma et al., 1995)

Consumers on the basis of choosing between domestic and foreign products or brands support the domestic economy (Granzin, Olsen, 1998). Balabanis and Diamantopoulos (2004) were the first to suggest that ethnocentricity better explains positive consumer attitudes towards domestic products than the negative attitude towards foreign products. Consumer ethnocentrism is also an important factor in determining the amount of reluctance to buy foreign products and also in determining the quality evaluation of products from foreign countries. (Suh, Kwon, 2002)

### Hypothesis development

Based on the literature review and identified gaps, we focused on ethnocentrism and examine its relative effect on buying behavior of domestic versus foreign products in the context of economic crisis in CEE.

Among others CE was adopted into marketing by Shimp and Sharma (1987) who say that: "Ethnocentric consumers believe it is wrong to purchase foreign-made products because it will hurt the domestic economy will cause the loss of jobs, and it is plainly unpatriotic." Later several studies confirmed the tendency of ethnocentric consumers to prefer for domestic rather than imported products (Sharma et al., 1995; Rawwas et al., 1996; Vida et al., 2008; Cleveland et al., 2009; Dmitrovic et al., 2009). However, Huddelston (Huddelston et al., 2000) suggested that consumers in transitional economies actually prefer foreign products. This presents an interesting deviation that is worth further examination.

Also, logic would suggest that CE would have a stronger, negative impact on foreign goods under conditions of recession, and additionally a positive impact on the decision to purchase domestic goods. As an economy, especially a small integrated one becomes more fragile, it also becomes more focal in the consumers mind. Thus, we would expect a magnification of CE impacts.

Thereof the first two hypotheses come:

*H1a: Under conditions of economic crisis in CEE, ethnocentricity has a positive effect on the purchasing of domestic products.*

*H1b: Under conditions of economic crisis in CEE, Ethnocentricity has a negative effect on purchasing foreign products.*

Empirical studies examine not only ethnocentricity as an important individual phenomenon (Sharma et al., 1995), but also the role of cultural openness, internationalism,

global mindedness, world mindedness, cosmopolitanism and national identity (Sharma et al., 1995). National identity can be understood as a "changing, socially-situated discursive construct, that is, an artifact that is dependent on the socio-political and cultural contexts in which the making of identity takes place." (Philippou, Klerides, 2010). *Therefore while exploring the impact of economic crisis the phenomenon of National Identity might play a significant role especially in small, still highly integrated and mobile economies, such as those of CEE, where the socio-political and cultural context has faced many changes within last two decades.*

Consumer preferences and purchase behavior have been shown to be affected by nationalism (Han, 1988; Baughn, Yaprak, 1993). Nationalism or National Identity was estimated to be positively linked to consumer ethnocentricity in most studies in the area.

Transitional CEE countries have traditionally been controlled or governed by larger neighbors, either for decades or centuries. Their relatively recent lack of sovereignty, suggests logically a higher focal on the potential to again lose self determination – either politically or economically. This in conjunction with a recession highlights the fragility of a small dependent economy. Thus, logic suggests that not only will there be the traditional theoretical link between national identity and ethnocentrism, but potentially a very strong relationship given the environment.

To test the relation between two above mentioned phenomenon next hypothesis was formulated as follows:

*H2: Under conditions of economic crisis in CEE, National Identification has a positive effect on ethnocentricity.*

Cosmopolitanism, originally introduced by Merton (1957) refers to a "world citizen", i.e. to an individual whose orientation goes beyond any particular culture or setting. The concept has been further developed in marketing literature by prominent researchers (Cannon, Yaprak, 2002; Thompson, Tambyah, 1999; Yoon et al., 1996) who argue that cosmopolitanism is consumer orientation with significant implication for marketing practice. Cosmopolitanism has been described also as internationalism, openness to foreign cultures, world-mindedness, worldliness or global openness. However, the recent review regarding cosmopolitanism shows (Riefler, Diamantopoulos, 2009) that its effects are not clarified. Especially, direct effects of cosmopolitanism on behavior in favor of purchasing foreign product brands have been rarely investigated, and its role as an influencing factor of

consumer ethnocentrism is largely left undetermined (Suh, Kwon, 2002; Vida et al., 2008).

Cosmopolitanism (and related constructs such as internationalism, global mindedness, world -mindedness, cultural openness) as driving factors of consumer ethnocentrism have been widely described in literature (Shankarmahesh, 2006). However, while theoretically suggested negative influence of cosmopolitanism on consumer ethnocentrism has been shown in several works (Cannon, Yaprak, 2002; Dmitrovic et al., 2009; Sharma et al., 1995; Vida, Reardon, 2008), there exists evidence to the contrary as well. In study of Suh and Kwon (2002) global openness had a significant negative effect on ethnocentrism in the US sample, but the relationship was insignificant in the Korean sample. Likewise, Strizhakova et al. (2008) examined this relationship across developed and emerging markets. Results showed a moderate negative relationship in the US sample, but no significant relationship in the emerging markets.

By nature, smaller CEE countries are economically dependent on their neighbors. This dependence has, by necessity, created cosmopolitanism within the region. Under previous regimes, travel and integration with the west was seriously restricted. Pent up demand for both western products and for interaction with the west created significant westernization upon independence of the CEE countries. Very dramatic shifts in western interactions occurred at a continual increasing pace. Integration and dependence with the EU, NATO, and in some cases Euro zone is indicative of this. The role of cosmopolitanism in forming consumers' attitude to purchasing foreign made goods has demonstrated contradictory results in the literature. Therefore the testing of the following hypothesis provides an opportunity for resolving the existing dispute as well as an interesting study of the specific situation.

*H3: Under conditions of economic crisis in CEE, Cosmopolitanism has a negative effect on ethnocentricity.*

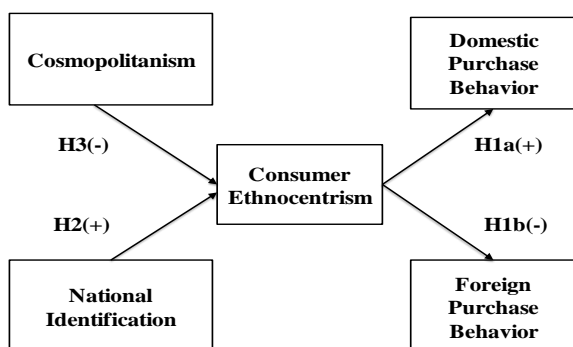

**Figure 2.** Description of model and hypotheses

### Methodology

**Sample.** Our sample frame was chosen based on the following criteria: 1. representative of CEE economies, and 2. significantly influenced during the economic crisis. Thus we chose the Czech Republic. The Czech Republic represents a newly developed, geographically smaller, high cosmopolitan country hit hard by the crisis. It is integrated locally (a member of the European Union) as well as

globally (a member of NATO) -still keeping its semi-independent attitude while not being a member of the Euro zone. Its population had to face dynamic changes in political, social and economic environment influencing from the market point of view the characteristics of purchase behavior. Resulting from the market consequences of a small opened economy, its population is familiar with foreign products now. It is neither the highest, nor lowest ranking economy (GDP per capita 13 797 EURO in 2010 (CZSO, 2011a), average inflation 1,5 % in 2010, unemployment 8,6 % in Q3 2010 (CZSO, 2011c)) or size (10 532 770 inhabitants by end of 2010 (CZSO, 2011b)).

The sample consisted of 199 respondents from Prague, the capital city of the Czech Republic. College students were chosen as subjects, based on several factors: a) relative homogeneity of extraneous influences (Burgess, Steenkamp, 2006; Coulter et al., 2005; Strizhakova et al., 2008b) relatively high exposure to global commerce (Gidley, 2002; Kjeldgaard, Askegaard, 2006) and c) relatively high exposure to multiple languages/cultures.

**Measures.** Construct measures for this research were derived from existing literature (Granzin, Olsen, 1998; Keillor et al., 1996; Parameswaran, Pisharodi, 1994; Yoon et al., 1996). All measures used have been proven psychometrically sound in cross-cultural contexts. CETSCALE, for example, has been used previously and validated in various cross-cultural contexts (e.g. Linquist et al., 2001; Good, Huddleston, 1995). For this study, the six-item version of the original scale was utilized to measure ethnocentrism. Seven-point Likert-type scales (1 = strongly disagree to 7 = strongly agree) were utilized for the individual scales to measure the five constructs.

In the process of translation and cross-cultural adaptation of the research stimuli and questionnaire (scale items), we followed the guidelines for conducting international consumer research by Craig and Douglas (1999) and by Douglas and Craig (2006).

Reliability of the scales was established using composite reliability (see Table 2). All reliability values are "respectable or better", i.e. higher than .7 ( DeVellis, 2003).

### Results and discussion

The estimation and t-test results are shown in Figure 3 below. As indicated below in Table 1 (below), the overall fit of the model is acceptable. As could be expected, the Chi-Squared statistic was significant. The other performance measures suggest that our model describes the data well within acceptable limits, as shown in Table 3. The RMSEA was below the 0.08 cutoff values suggested by Browne and Cudeck (1993). In addition, the CFI is above the commonly recommended 0.90 limit (Lichtenstein et al., 1992).

Table 1

Model fit	
Chi-Squared	286.38 df=147
RMSEA	0.069
CFI/IFI	0.96
RFI	0.90
GFI	0.88

Table 2

Construct/Items	Composite Reliability	AVE
<b>National Identification (NatID)</b> (Adapted from Keillor et al., 1996 ) 1. Being a Czech citizen means a lot to me 2. I am proud to be a Czech citizen 3. When a foreign person praises Czech Rep., it feels like a personal compliment 4. I feel strong ties with Czech Rep.	.8879	.7097
<b>Cosmopolitanism (Cosmo)</b> (Adapted from Yoon et al, 1996) 1. I like immersing myself in different cultural environments 2. I like having contact with people from different cultures 3. I would enjoy travelling to foreign countries for an extended period of time 4. Getting information and news from around the world is important to me	.8580	.6660
<b>Ethnocentricity (CET Scale)</b> (Adapted from Shimp and Sharma 1987) 1. Only those products that are unavailable in Czech Rep. should be imported 2. Czech products, first, last and foremost 3. A real Czech citizen should always buy Czech-made products 4. Czech citizens should not buy foreign products, because this hurts the Czech Republic's business and causes unemployment 5. It may cost me in the long-run, but I prefer to support Czech products 6. Czech consumers who purchase products made in other countries are responsible for putting their fellow Czech citizens out of work	.8548	.6166
<b>Domestic Purchase Behavior (BuyDom)</b> (Adapted from Grazen and Olsen 1998) 1. I try to buy mostly domestic brands 2. I take time to look at labels in order to knowingly buy more domestic brands 3. I shop at retail stores that make a special effort to offer domestic brands	.9013	.7784
<b>Foreign Purchase Behavior (BuyFor)</b> (Adapted from Grazen and Olsen 1998) 1. I like the idea of owning foreign products 2. My quality of life would improve if more imported goods were available 3. I find imported goods more desirable than domestically produced products	.7934	.6316

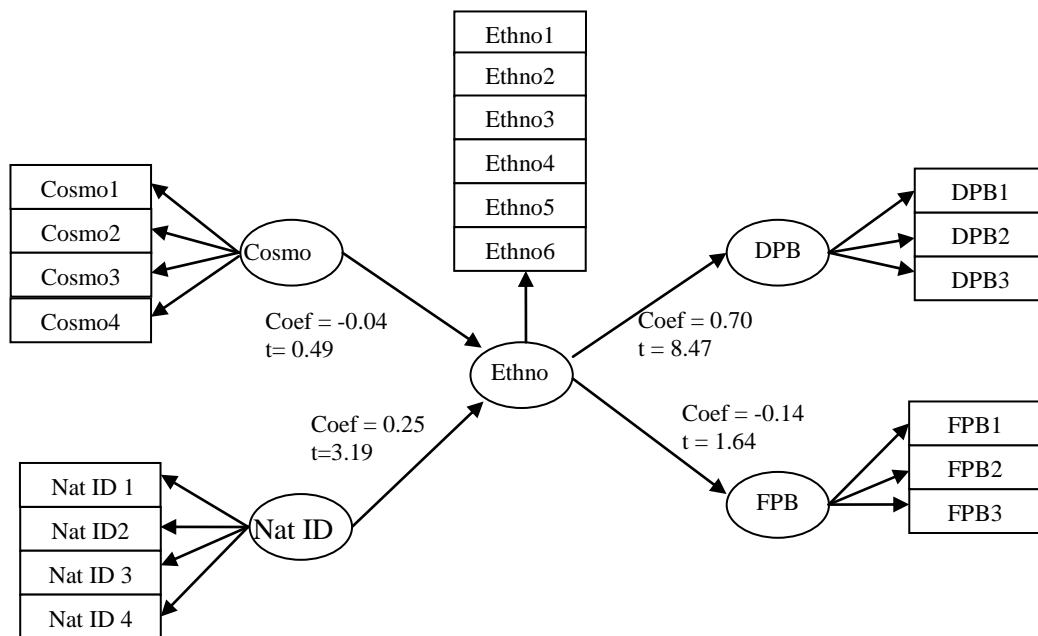

Figure 3. Estimation and t-test results

The hypotheses are tested by examining the individual structural paths of the model (Table 3).

Table 3

**Hypotheses Results**

Hypotheses	Linkage	Estimate	t/p-value	Result
H1a:	CET→ BuyDom (+)	0.70	8.47, p<.001	Supported
H1b:	CET→ BuyFor (-)	-0.14	1.64, p=.052	Marginal
H2:	NatID → CET (+)	0.25	3.19, p<.001	Supported
H3:	Cosmo → CET (-)	-0.04	0.49, p=.312	Rejected

Hypothesis H1a is supported, hypothesis H1b is marginally supported, hypothesis H2 is supported, hypothesis H3 is rejected. The result of the research shows that ethnocentric attitudes of consumers have a positive effect on domestic purchase behavior, while only marginally negative effect on foreign purchase behavior. National identification has positive effect on ethnocentricity while negative effect of cosmopolitanism on ethnocentricity was not supported.

Concerning the theoretical background of how ethnocentricity, national identity and cosmopolitanism are defined and understood within the marketing field and our paper. It seems there is a very interesting aspect to be observed. National Identity has a positive effect on domestic purchase behavior but we cannot say that cosmopolitanism would act in the other direction.

As expected, H1a was supported. Interestingly, support for H1b was only marginal. This is in line with previous research findings that suggest that CE affects domestic product preferences more than foreign. It is also somewhat intuitive given the nature of the study. Smaller CEE countries would be expected to have residual preferences for foreign goods, thus even under conditions of recession there would be a tendency to buy local rather than the tendency to become protectionist.

As suggested by the logic of the development of H2, it is unsurprising to find relatively strong effects of National Identity on CE. However, more interesting is the lack of effect of H3 – Cosmo on CE. In hindsight, we might suggest that the relatively high level of cosmopolitanism in small CEE countries results in a more uniform distribution, and thus a lack of variance, relatively, within the country. Thus, integration of CEE countries simply may not reduce CE, but rather act in some other manner on the decision process – even potentially ignoring the CE construct in general by taking a wide view of ‘citizen of the world’ – in which case CE simply cannot exist.

Having a deeper look on the Czech Republic and the CEE more generally, there might be a couple of explanatory factors of these results. The Czech Republic or the Czech nation has quite a long and fruitful history concerning, culture, industry, education and so on. Still it has most often been a part of a bigger kingdom, state or groups of states. Czechs found a way to stay Czech and simultaneously to succeed within the current environment. In the recent history it became a small open economy situated in the heart of Europe, where consumers are facing

foreign elements in their daily life on different levels, for example foreign TV & radio broadcasting, proportion of foreign movies and other programmers within the regular national broadcasting, local cross-border social (e.g. health care) and economic cooperation (employment, shopping), spending vacation abroad. Interestingly, the same is true for most small CEE countries.

**Conclusions**

Czech ethnocentricity supports buying of domestic products, we see that one of the best ways to mitigate sharpened competition serving players on both sides – supply and demand – supporting better recognition of Czech products of good quality was foundation of a brand KLASA, awarding the best quality food and agricultural products. It is being awarded by ministry of agriculture of the Czech Republic as of 2003. Up to date 1300 products from 2022 Bohemian and Moravian producers gained this prestigious award which is valid for three years. (ČTK, 2010b)

According to the research by STEM/MARK agency (ČTK, 2010b) “...the sales of Klasa products increased by 20-43 % in retail chains between 2008 and 2010.” 71 % of respondents think that Klasa helps them to select food products and 67 % are directly buying Klasa products. More than two-thirds of women prefer Klasa food products to others. 76 % of producers claim that Klasa logo has a positive effect on sales of their food products.

More than two-thirds of them are making effort to gain this brand for other of their products. Even in times of recent economic crisis which is strongly pressuring food prices downwards, Czech consumers appreciate freshness as factor number one and quality as factor number two during the purchasing process. Regarding comparison of quality of Czech versus foreign food products 81 % of respondents assume that Czech products are mostly of higher quality than the ones from foreign producers.

The results of the research reflect resent field survey among Czech consumers. According to GfK research (ČTK, 2011): Czech customers prefer domestic products, mainly foodstuff: 84 % prefer Czech beer, 83 % domestic meat and meat products, 78 % domestic dairy products; while only 5 % at cosmetics. “Domestic food product preferences demonstrate strongly older respondents, 79 % of respondents over 55 years claimed that they prefer Czech brands, while only 67 % of respondents aged 15 to 35 claimed the same.” In the same research 86 % of respondents stated “it is important for me that Czech good is produced in the Czech Republic” and 61% stated “I am interested whether the Czech product has a Czech owner”. 97 % of respondents named as key decision buying criteria freshness and quality.

Concerning the success of long-term campaign Klasa within the food market, and recent economic situation, also producers of non-food consumer goods and services launched activities supporting quality and its promotion addressing consumers. The program is labeled Czech Quality; while a program branded Local Food Product (lokální potravina) is expected to be launched soon.

Key findings provide useful information to marketing specialists in designing their marketing strategies for “Czech

made” versus foreign products, as well as, for retailers to evaluate their profitability given the consumer preferences.

According to the results of the research shortly saying that Czech consumer prefers to buy Czech products, and simultaneously believes that Czech products are of good quality and positively is willing to exploit the initiative of Klasa and similar brands guaranteeing Czech quality goods marketing executives as well as state policy makers should deepen this activity and continue in similar support of this trend.

Should we build on the positive influence of Czech CE on buying behavior of domestic products versus foreign, and preference for freshness and quality of goods, there are options to appear in economic potential for job creation and employment, especially within the area of small local producers, self-employment, development of local agriculture, as well as countryside maintenance.

Given these results, the companies should cooperate and with the assistance of national economic policy support prosperous retail environment, using the national identification which has a positive effect (through ethnocentricity – please see our hypotheses) on buying domestic products.

Ideally, the Czech Republic will be successful in creation and maintenance of magical circle of quality products (producing quality goods - willingness to buy quality goods - continuous profit of companies - resources for quality improvement - producing quality goods).

Concerning all the variables coming into the decision making process of building retail strategies product is the core around which everything revolves and so needs to be

paid attention. Resulting from today’s world globalization one of the significant questions (among many others) heading as a golden line throughout both management and marketing issues which such companies are facing is the following one: “What product should we sell and what image should our products reach?” Or to make it even more specific: “What brand should be chosen to label our products, while placed in the store to make them be attractive enough to be desired, wanted, bought and consumed in a maximum volume possible by customers on various markets. This article is focusing on the principle differences in appropriate management and marketing strategies which arise between the domestic and foreign markets from the point of view of international corporations trying to find the best solution for satisfying consumer needs resulting in positive consumer preferences and of course in increased popularity and sales through the appropriate product image and labeling.

### **Limitations and future research**

Possible limitation represents the fact that the research was designed and carried out using a sample of university students and a single country analysis. Both of which were intentionally chosen as appropriate for the particular tasks of the research.

Given the results of the research further investigation could focus on the results of testing of the hypothesis H1b (H1b: Ethnocentric attitudes of consumers have a negative effect on foreign purchase behavior) which only was marginally supported.

### **References**

- Al-Sulaiti, K. I., & Baker, M. J. (1998). Country of: Origin Effects: a Literature Review. *Marketing Intelligence & Planning*, 16(3), 150-199. <http://dx.doi.org/10.1108/02634509810217309>
- AutoFox. (2010). AAA Auto: Cesti Spotrebitele se Vraceji od Zahranicnich Znacek ke Skode. *Autofox*, 2.11.2010, [www.Autofox.cz](http://www.Autofox.cz).
- Balabanis, G., & Diamantopoulos, A. (2008). Brand Origin Identification by Consumers: A Classification Perspective. *Journal of International Marketing*, 16(1), 39-71. <http://dx.doi.org/10.1509/jimk.16.1.39>
- Balabanis, G., & Diamantopoulos, A. (2004). Domestic Country Bias, Country-of-Origin Effects, and Consumer Ethnocentrism: a Multidimensional Unfolding Approach. *Journal of Academy of Marketing Science*, 32(1), 80-95. <http://dx.doi.org/10.1177/0092070303257644>
- Balabanis, G., Diamantopoulos, A., Mueller, R. D., & Melewar, T. C. (2001). The Impact of Nationalism, Patriotism and Internationalism on Consumer Ethnocentric Tendencies. *Journal of International Business Studies*, (32), 157-175. <http://dx.doi.org/10.1057/palgrave.jibs.8490943>
- Batra, R., Ramaswamy, V., Alden, D., Steenkamp, J., & Ramachander, S. (2000). Effects of Brandlocal and Nonlocal Origin on Consumer Attitudes in Developing Countries. *Journal of Consumer Psychology*, 9(2), 83-95. [http://dx.doi.org/10.1207/S15327663JCP0902\\_3](http://dx.doi.org/10.1207/S15327663JCP0902_3)
- Baughn, C., & Yaprak, A. (1993). Mapping Country-of-Origin Research: Recent Developments and Emerging Avenues. In Papadopoulos, N., & Heslop, L. A., (Eds.), *Product-Country Images: Impact and Role in International Marketing*, 89-116. New York: International Business Press.
- Bawa, A. (2004). Consumer Ethnocentrism: CETSCALE Validation and Measurement of Extent. *Vikalpa*, 29(3), 43-58.
- Browne, M. W., & Cudeck, R. (1993). *Alternative Ways in Assessing Model Fit. Testing Structural Equations Models*. eds. Bollen and Long; Sage Publications.
- Burgess, S., & Steenkamp, J. B. (2006). Marketing Renaissance: How Research in Emerging Markets Advances Marketing Science and Practice. *International Journal of Research in Marketing*, 23(4), 337-356. <http://dx.doi.org/10.1016/j.ijresmar.2006.08.001>
- Cannon H. M., & Yaprak, A. (2002). Will the Real-World Citizen Please Stand Up! Many Facets of Cosmopolitan Consumer behavior. *Journal of International Marketing*, 10(4), 30-52. <http://dx.doi.org/10.1509/jimk.10.4.30.19550>

- Cleveland, M., Laroche, M., & Papadopoulos, N. (2009). Cosmopolitanism, Consumer Ethnocentrism, and materialism: An Eight-Country Study of Antecedents and Outcomes. *Journal of International Marketing*, 17(1), 116-146. <http://dx.doi.org/10.1509/jimk.17.1.116>
- Coulter, R., Price, L., Feick, L., & Micu, C. (2005). The Evolution of Consumer Knowledge and Sources of Information: Hungary in Transition. *Journal of the Academy of Marketing Science*, 33(4), 604-619. <http://dx.doi.org/10.1177/0092070305278512>
- Craig, C. S., & Douglas, S. P. (1999). *International Marketing Research*. New York, NY: John Wiley & Sons, LTD.
- Crawford, J. C., & Lamb, C. W. (1982). Effect of Worldmindedness Among Professional Buyers Upon their Willingness to Buy Foreign Products. *Psychological Reports*(50), 859-862. <http://dx.doi.org/10.2466/pr0.1982.50.3.859>
- CZSO. (2011a). Macroeconomic Indicators. 1.4.2011, <http://www.czso.cz/>.
- CZSO. (2011b). Population. 1.4.2011, [http://www.czso.cz/csu/redakce.nsf/i/obyvatelstvo\\_lide/](http://www.czso.cz/csu/redakce.nsf/i/obyvatelstvo_lide/).
- CZSO. (2011c). Zmeny v zamestnanosti a nezamestnanosti v Ceske republice v porovnani s ostatnimi zememi EU. 1.2.2011, <http://www.czso.cz/csu/csu.nsf/informace/czam020111.doc>.
- ČTK. (2010a). Kvalita potravin podle spotřebitelu stoupa. *Marketing&Media*, 14.6.2010, <http://mam.ihned.cz/>.
- ČTK. (2010b). Prodej potravin se znackou kvality Klasa roste. *Marketing&Media*. 14.12.2010, <http://mam.ihned.cz/>.
- ČTK. (2011). Cesi pri nakupu preferuji domaci zbozi hlavne u potravin. 28.1.2011, <http://mam.ihned.cz/>.
- EURO.CZ. (2010). Logo Klasa ma vliv na lepší prodej potravin. 13.12.2010, [www.euro.cz](http://www.euro.cz).
- Cumberland, F., Solgaard, H.S., & Nikodemska-Wolowik, A.M. (2010). The Effects of Consumer Ethnocentrism and Country of Origin on Polish Consumers' Evaluation of Foreign Manufactured Products. *Journal of East-West Business*, 16(3), 231-252. <http://dx.doi.org/10.1080/10669868.2010.523374>
- de Mooij, M., & Hofstede, G. (2002). Convergence and Divergence in Consumer Behavior: Implications for International Retailing. *Journal of Retailing*, 78(1), 61-69. [http://dx.doi.org/10.1016/S0022-4359\(01\)00067-7](http://dx.doi.org/10.1016/S0022-4359(01)00067-7)
- Dedeoglu, A. O., Savasci, I., & Ventura, K. (2005). Consumer Ethnocentrism Portrayed in the Advertising and Meanings Actualized by Consumers: A case of turkey. *Asia Pacific Advances in Consumer Research*, (6), 274-279.
- DeVellis, R. F. (2003). *Scale Development: Theory and Applications*, 2<sup>nd</sup> Ed., Sage Publications, Thousand Oaks.
- Dinnie, K. (2004). Country-of-Origin 1965-2004: A Literature Review. *Journal of Customer Behavior*, (3), 165-213. <http://dx.doi.org/10.1362/1475392041829537>
- Dmitrovic, T., Vida, I., & Reardon, J. (2009). Purchase behavior in favor of domestic products in West Balkans. *International Business Review* (18), 523-535. <http://dx.doi.org/10.1016/j.ibusrev.2009.05.003>
- Douglas, S., & Craig, C. S. (2006). On Improving the Conceptual Foundations of International Marketing Research. *Journal of International Marketing*, 14(1), 1-22. <http://dx.doi.org/10.1509/jimk.14.1.1>
- Elliott, G., & Cameron, R. (1994). Consumer Perception of Product Quality and the Country of Origin Effect'. *Journal of International Marketing*, 2(2), 49-62.
- Gidley, J. (2002). Global Youth Culture: A Transdisciplinary Perspective, in Jennifer Gidley and Sohail Inayatullah, eds., *Youth Futures: Comparative Research and Transformative Visions*, Santa Barbara, CA: Praeger Publishers, 3-18.
- Good, L. K., & Huddleston, P. (1995). Ethnocentrism of Polish and Russian Consumers: Are Feelings and Intentions Related? *International Marketing Review*, 12(5), 35-48. <http://dx.doi.org/10.1108/02651339510103047>
- Granzin, K. L., & Olsen, J. E. (1998). Americans' Choice of Domestic over Foreign Products: A Matter of Helping Behavior? *Journal of Business Research* (43), 39-54. [http://dx.doi.org/10.1016/S0148-2963\(97\)00101-X](http://dx.doi.org/10.1016/S0148-2963(97)00101-X)
- Han, C. M. (1988). The Role of Consumer Patriotism in the Choice of Domestic Versus Foreign Products. *Journal of Advertising Research*, (June/July), 25-32.
- Herche, J. (1994). Ethnocentric Tendencies, Marketing Strategies and Import Purchase behavior. *International Marketing Review*, 11(3), 4-16. <http://dx.doi.org/10.1108/02651339410067012>
- Huddleston, P., Good, L. K., & Stoel, L. (2000). Consumer Ethnocentrism, Product Necessity and Quality Perceptions of Russian Consumers. *International Review of Retail, Distribution and Consumer Research*, 10(2), 167-181. <http://dx.doi.org/10.1080/095939600342343>
- Kaynak, E., & Cavusgil, S. T. (1983). Consumer Attitudes Toward Products Of Foreign Origin: Do They Vary Across Product Classes? *International Journal of Advertising* (2), 147-157.
- Keillor, B. D., Hult, G. T. M., Erffmeyer, R. C., & Babakus, E. (1996). NATID: The Development and Application of a National Identity Measure for Use in International Marketing. *Journal of International Marketing*, 4(2), 57-73.
- Kjeldgaard, D., & Askegaard, S. (2006). The Globalization of Youth Culture: The Global Youth Segment as Structures of Common Differences. *Journal of Consumer Research*, 33(2), 231-247. <http://dx.doi.org/10.1086/506304>



- Laroche M., Papadopoulos N., Heslop L. A., & Mourali M. (2005). The Influence of Country Image Structure on Consumer Evaluations of Foreign Products. *International Marketing Review*, 22(1), 96-115. <http://dx.doi.org/10.1108/02651330510581190>
- Levitt, T. (1983). The Globalization of Markets. *Harvard Business Review*, May-June, 92-102.
- Lichtenstein, D., Ridgway, N., & Netemeyer, R. (1992). Price Perceptions and Consumer Shopping behavior: A Field Study. *Journal of Marketing Research*, 30(May), 234-245.
- Liefeld, J. P. (2004). Consumer Knowledge and use of Country-of-Origin Information at the Point of Purchase. *Journal of Consumer Behaviour* 4(2), 85-96. <http://dx.doi.org/10.1002/cb.161>
- Linguist, J. D., Vida, I., Plank, R., & Fairhurst, A. (2001). The Modified CETSCALE: Validity Tests in the Czech Republic, Hungary and Poland. *International Business Review*, 10(5), 505-516. [http://dx.doi.org/10.1016/S0969-5931\(01\)00030-0](http://dx.doi.org/10.1016/S0969-5931(01)00030-0)
- Hsu, J. L., & Nien, H.-P. (2008). Who are ethnocentric? Examining Consumer Ethnocentrism in Chinese Societies. *Journal of Consumer Behaviour* (7), 436-447. <http://dx.doi.org/10.1002/cb.262>
- Merton, R. K. (1957). Pattern of Influence: Local and Cosmopolitan Influentials. In R. K. Merton (Ed.). *Social Theory and Social Structure* (pp. 387-420), Glencoe, Ill, the Free Press.
- Khan, M.N., & Rizvi, S.R. (2008). Consumer Ethnocentrism: Relevance and Implications for Marketers. *ICFAI Journal of Consumer Behaviour*, 3(1), 52-65.
- Nijssen, E. J., & Douglas, S. P. (2004). Examining the Animosity Model in a Country with a High Level of Foreign Trade. *International Journal of Research in Marketing*, (21), 23-38. <http://dx.doi.org/10.1016/j.ijresmar.2003.05.001>
- Parameswaran, R., & Pisharodi, R. M. (1994). Facets of Country of Origin Image: An Empirical Assessment. *Journal of Advertising*, 23(1), 43-56.
- Parts, O. (2007). The Measurement of Consumer Ethnocentrism and COO Effect in consumer research. *Transformations in marketing Applications: The Baltics*, 6(1), 139-54.
- Peterson, R. A., & Jolibert, A. J. P. (1995). A Meta-Analysis of Country-Of-Origin Effects. *Journal of International Business Studies*, 26(4), 157-175. <http://dx.doi.org/10.1057/palgrave.jibs.8490824>
- Pharr, J.M. (2005). Synthesizing Country-of-Origin Research From the last Decade: Is the Concept Still Salient in an Era of Gglobal Brands? *Journal of Marketing Theory and Practice*, 13(4), 34-45.
- Phillippou, S., & Klerides, E. (2010). On Community and Change in National Identity Construction: An Initial Note on Greek- Cypriot Education, 1960-2010. *The Cyprus review*, 22(2).
- Puzakova, M., Kwak, H., & Andras, T. L. (2010). Brand Anthropomorphization: A Homocentric Knowledge Activation Perspective. Association for Consumer Research, Jacksonville, FL.
- Rawwas, M. Y. A., Rajendran, K. N., & Wuehrer, G. A. (1996). The Influence of Worldmindness and Nationalism on Consumer Evaluation of Domestic and Foreign Products. *International Marketing Review*, 13(2), 20-38. <http://dx.doi.org/10.1108/02651339610115746>
- Reardon, J., Miller, C., Vida, I., & Kim, I. (2005). The Effects of Ethnocentrism and Economic Development on the Formation of Brand and ad Attitudes in Transitional Economies. *European Journal of Marketing*, 39(7/8), 737-754. <http://dx.doi.org/10.1108/03090560510601743>
- Riefler, P., & Diamantopoulos, A. (2009). Consumer Cosmopolitanism: Review and Replication of the CYMYC Scale. *Journal of Business Research* (62), 407-419. <http://dx.doi.org/10.1016/j.jbusres.2008.01.041>
- Samiee S., Shimp T., & Sharma S. (2005). Brand Origin Recognition Accuracy: Its Antecedents and Consumers' Cognitive Limitations. *Journal of International Business Studies*, 36(4), 379-398. <http://dx.doi.org/10.1057/palgrave.jibs.8400145>
- Shankarmahesh, M. N. (2006). Consumer Ethnocentrism: an Integrative Review of its Antecedents and Consequences. *International Marketing Review*, 23(2), 146-172. <http://dx.doi.org/10.1108/02651330610660065>
- Sharma, S., Shimp, T.A., & Shin, J. (1995). Consumer Ethnocentrism: A Test of Antecedents and Moderators. *Journal of Academy of Marketing Science*, 23(1), 26-37. <http://dx.doi.org/10.1007/BF02894609>
- Shimp, T. A., & Sharma, S. (1987). Consumer Ethnocentrism: Construction and Validation of the CETSCALE. *Journal of Marketing Research*, (24), 280-289. <http://dx.doi.org/10.2307/3151638>
- Strizhakova, Y., Counter, R., & Price, L. (2008). The Meanings of Branded Products: A Cross-National Scale Development and Meaning Assessment. *International Journal of Research in Marketing*, 25(2), 82-93. <http://dx.doi.org/10.1016/j.ijresmar.2008.01.001>
- Suh T., Kwon I-W.G. (2002). Globalization and Reluctant Buyers. *International Marketing Review*, 19(6), 663-80. <http://dx.doi.org/10.1108/02651330210451962>
- Thompson, C. J., & Tambya, S. K. (1999). Trying to be Cosmopolitan. *Journal of Consumer Research*, (26), 214-241. <http://dx.doi.org/10.1086/209560>

- Verlegh, P. W. J., & Steenkamp, J. B. E. M. (1999). A Review and Meta-Analysis of Country-Of-Origin Research. *Journal of Economic Psychology*(20), 521-546. [http://dx.doi.org/10.1016/S0167-4870\(99\)00023-9](http://dx.doi.org/10.1016/S0167-4870(99)00023-9)
- Vida, I. T., & Reardon, J. (2008). Domestic Consumption: Rational, Affective, or Normative Choice? *Journal of Consumer Marketing*, 25(1), 34-44. <http://dx.doi.org/10.1108/07363760810845390>
- Vida, I., & Damjan, J. (2000). The Role of Consumer Characteristics and Attitudes in Purchase behavior of Domestic vs. Foreign Made Products: The Case of Slovenia. *Journal of East-West Business*, 6(3), 111-131. [http://dx.doi.org/10.1300/J097v06n03\\_06](http://dx.doi.org/10.1300/J097v06n03_06)
- Vida, I., & Dmitrovic, T. (2001). An Empirical Analysis of Consumer Purchasing behavior in Southeastern European Markets. *Economic and Business Review* 3(3/4), 191-207.
- Vida, I., Dmitrovic, T., & Obadia, C. (2008). The Role of Ethnic Affiliation in Consumer Ethnocentrism. *European Journal of Marketing*, 42(3/4), 327-343. <http://dx.doi.org/10.1108/03090560810852968>
- Yelkur, R., Chakrabarty, S., & Bandyopadhyay, S. (2006). Ethnocentrism and Buying Intentions: Does Economic Development Matter? *Marketing Management Journal*, 16(1), 26-37.
- Yoon S. J., Cannon H. M., & Yaprak, A. (1996). Evaluating the CYMYC Cosmopolitanism Scale on Korean Consumers. *Advances in International Marketing*, (7), 211-32.

Zuzana Kreckova, Jitka Odehnalova, James Reardon

### Vartotojo etnocentriškumas ekonominės krizės aplinkoje

Santrauka

Iki nepriklausomybės, prekių tiekimas Centrinės ir Rytų Europos šalyse dėl centralizuotos planinės ekonomikos buvo labai ribotas. Taigi, 1989 metais, kirtus „Geležinei uždangai“, vartotojai turėjo didžiulę aistrą užsienio gaminiams, o jų pirkimą palaikė aukštos kokybės rinkodaros užsienio kompanijos, kurios buvo sukurtos ir išmokytos dirbti labai konkurencingoje rinkoje. Žvelgiant iš pastarųjų dešimtmečių perspektyvos matyti, kad daugelis Centrinės ir Rytų Europos gamintojų, mažmenininkų ir kitų dalyvių bei vartotojų pradėjo konkuruoti su kolegomis iš vakarų. Taip prasidėjo grįžimas prie savoje šalyje pagamintų produktų.

Rinkodaros specialistai yra susidūrę su vartotojais, turinčiais savo nuomonę apie gaminį, pagamintą kitose šalyse. Pagaminimo vieta turi didžiulę reikšmę vartotojui. Tai patvirtino ir atliktas, dešimtmečius trukęs tyrimas, kuris tik patvirtino, kad kilmės šalis, kurioje pagamintas produktas ar gaminys yra labai svarbi vartotojų požiūriui, jų pasirinkimui ir ketinimui pirkti (Pharr, 2005; Laroche ir kt., 2005). Laikui bėgant buvo atliktas tyrimas dviem kryptim. Pirmoji sutelkė dėmesį į vartotojo pasirinkimą perkant tam tikrų šalių gaminius (t.y., šalies-įvaizdžio tyrimai; Dmitrovic, Vida, 2010; Roth, Diamantopoulos, 2009), antroji tyrimo kryptis sutelkė dėmesį į veiksmus, kurie turi įtaką vartotojams renkantiems vietinius ar užsienio gaminius (Vida ir kt., 2008; Sharma ir kt., 1995; Crawford, Lamb, 1982). Šis tyrimas skirtas antrajai tyrimo krypciai.

Šiame darbe nagrinėjamas vartotojų gaminių pasirinkimas Centrinės ir Rytų Europos šalyse, esant ekonominei krizei. Tiksliau sakant, kokiam produktui: savam ar pagamintam kitoje šalyje pirmenybę teikia vartotojas. Šio darbo tikslas yra išnagrinėti Čekijos vartojimo tendencijas ekonominės krizės metu, nustatyti vartotojo etnocentriškumo lygį bei veiksmus, darančius įtaką perkant/ pasirenkant vietinių ir užsienio gamintojų gaminius. Remiantis literatūros apžvalga ir išsiaiškinus kai kuriuos trūkumus, dėmesys buvo sutelktas į etnocentrizmo analizę. Buvo išnagrinėti veiksniai, lemiantys vietinių gaminių pirkimo pasirinkimą ir palyginami su užsienio gaminių pirkimu ekonominės krizės metu Centrinėje ir Rytų Europoje. Atsižvelgiant į konceptualią struktūrą, buvo iškeltos šios tyrimo hipotezės: H1a: ekonominės krizės Centrinėje ir Rytų Europoje sąlygomis, etnocentriškumas daro teigiamą įtaką vietinių gaminių pirkimui.

H1b: ekonominės krizės Centrinėje ir Rytų Europoje sąlygomis, Etnocentriškumas daro neigiamą įtaką užsienio gaminių pirkimui.

H2: ekonominės krizės Centrinėje ir Rytų Europoje sąlygomis, nacionalinė identifikacija daro teigiamą įtaką etnocentriškumui.

H3: ekonominės krizės Centrinėje ir Rytų Europoje sąlygomis, kosmopolitizmas daro neigiamą įtaką etnocentriškumui.

Hipotezės buvo patikrintos panaudojant struktūrinės lygties modeliavimą. Analizuotą pavyzdį sudarė 199 Čekijos respondentai. Rezultatai patvirtina vartotojo etnocentriškumą įtaką pirkimo elgesiui ir nacionalinės tapatybės įtaką vartotojo etnocentriškumui. Čekijoje vartotojo etnocentriškumas daro didelę, teigiamą įtaką pasirenkant vietinių gamintojų pirkinius, o vartotojo etnocentriškumo įtaka užsienio gaminiams pirkti buvo gan nežymi. Kosmopolitizmas neturėjo įtakos Čekijoje.

Remiantis tyrimo rezultatais, įrodančiais didelę vartotojo etnocentriškumo įtaką Čekijos vartotojo pirkimo elgesiui, naudinga toliau tirti Čekijos etnocentriškumo įtaką paslaugų ir darbo rinkai. Gauti rezultatai leis geriau suprasti etnocentrizmo reiškinį ir veiksmus, lemiančius didesnę vietinių gaminių pirkimo pasirinkimą nei užsienio gaminių Čekijoje. Darbe susitelkiama ties sritimi, kurią labiausiai pažeidė ekonominė krizė Centrinėje ir Rytų Europoje. Atlikto tyrimo rezultatai naudingi rinkos specialistams, kuriantiems savo rinkodaros strategijas. Tai naudinga taip pat ir mažmenininkams, norintiems įvertinti, išsiaiškinti savo asortimentą atsižvelgiant į vartotojų poreikius. Pirmenybę savai produkcijai, o ne užsienio turi daug privalumų. Atsiranda galimybė kurti daugiau naujų darbo vietų, ypač srityse, kur yra smulkūs vietiniai gamintojai. Poreikis vietinei produkcijai skatina ir šalies žemės ūkio plėtrą, taip pat tai turi įtaką ir gaunant kaimo paramą. Ši tema atrodo tampa vis svarbesne, todėl būtų labai įdomu ateityje pasiekti kaip dabartiniai integracijos procesai tiesiogiai ir netiesiogiai daro įtaką Centrinės ir Rytų Europos šalims.

Atidžiau pažvelgus į Čekijos respubliką ir Centrinės ir Rytų Europos šalis, galima pamatyti keletą šių rezultatų paaiškinančių veiksnių. Čekijos respublika arba čekų tauta turi pakankamai ilgą ir turtingą kultūros, pramonės, švietimo istoriją, tačiau ji visada buvo kurios nors didesnės karalystės, valstybės ar valstybių grupės dalis. Nepaisant to, Čekija rado būdą kaip likti čekais ir tuo pat metu klestėti esamoje aplinkoje. Visai neseniai ji tapo maža atvira šalimi, esančia Europos viduryje, kur gyventojai susiduria su globalizacija savo gyvenime pvz.: užsienio televizijos ir radijo transliacijos, užsienio filmų ir kitų programų dalis įprastinėje šalies televizijoje, vietinis socialinis (pvz., sveikatos apsauga) ir ekonominis (įdarbinimas, apsipirkimas) bendradarbiavimas su užsieniu, atostogos užsienyje. Įdomiausia, kad tai yra ir daugumoje kitų, mažų Centrinės ir Rytų Europos šalių.

Čekų etnocentriškumas akivaizdus. Jie remia vietinius gamintojus pirkdami savo šalies produkciją. Tačiau konkurencija išlieka. Todėl manoma, kad vienas iš geriausių būdų norint palaikyti Čekijos gaminius, kurių kokybė visuotinai pripažinta, sukurti prekių ženklą. Taip buvo sukurtas prekių ženklas KLASA. Jis Čekijoje skiriamas apdovanojant geriausios kokybės maisto ir žemės ūkio gaminius. Juo nuo 2003 metų apdovanoja Čekijos Respublikos žemės ūkio ministerija.

Remiantis tyrimo rezultatais, galima teigti, kad Čekijos vartotojai renkami pirkti čekiškus gaminius todėl, kad čekų gaminiai yra geros kokybės. Rinkodaros vadovai ir valstybės politikai turėtų įvertinti KLASA ir panašių prekių ženklų reikšmę ir svarbą Čekijos ekonomikai ir prisidėti prie šios veiklos plėtros ir skatinimo.

Esant tokiems rezultatams, kompanijos galėtų bendradarbiauti tarpusavyje ir, pasinaudodamos šalies pritarimu, kuris daro teigiamą įtaką (dėl etnocentriškumo – prašome žiūrėti mūsų hipotezes) vietinių gaminių pirkimui, palaikyti klestinčią mažmeninės prekybos aplinką.

Būtų geriausia, kad Čekijos respublika sėkmingai kurtų ir išlaikytų gaminių kokybės asortimentą (kokybiškų prekių gamyba – noras pirkti kokybiškas prekes – besitęsiantis kompanijų pelnas – resursai kokybės gerinimui – kokybiškų prekių gamyba).

Dėl visų kintamųjų sudarančių mažmeninės prekybos strategijos kūrimo sprendimų priėmimo procesą, gaminyje visada yra centras, apie kurį visas sukasi, todėl į jį reikia nuolat atkreipti dėmesį. Vienas iš svarbiausių ir daugelio klausimų šiais globalizacijos laikais, valdymo, ir rinkodaros leidiniuose vadinamas auksine linija, ir su kuriuo susiduria įvairios kompanijos, yra: „Koki gaminį mes parduotume ir kokią reputaciją pasiektų mūsų gaminiai?“ Arba suformuluokime jį dar tiksliau: „Kokį prekės ženklą reiktų pasirinkti mūsų gaminiams žymėti, kad jiems esant parduotuvėje jie atrodytu pakankamai patrauklūs, kad jų trokštų, norėtų, pirktų ir vartotų didžiausiais galimais kiekiais įvairių rinkų vartotojai“. Šis straipsnis sutelkia dėmesį į pagrindinius skirtumus valdymo ir rinkodaros strategijose, kurie atsiranda tarp vietinės ir užsienio rinkos tarptautinių korporacijų, bandančių rasti geriausią sprendimą kaip patenkinti vartotojų poreikius. O viso to rezultatas yra teisingas vartotojų pasirinkimas ir žinoma didesnis populiarumas ir pardavimai dėl atitinkamo gaminio įvaizdžio ir žymėjimo.

Galimi darbo apribojimai buvo tokie, kad tyrimas atliktas naudojant kaip pavyzdį universiteto studentų ir atskiros šalies analizę, iš kurių abu buvo iš anksto pasirinkti kaip tinkantys tam tikroms tyrimo užduotims. Atsižvelgiant į tyrimo rezultatus, tolesni tyrimai galėtų sutelkti dėmesį į hipotezės H1b tikrinimo rezultatus (H1b: Etnocentriškas vartotojų požiūris daro neigiamą įtaką užsienio pirkėjų elgesiui) kuris buvo paremtas tik nežymiai.

Rakatažodžiai: *etnocentrizmas, kosmopolitizmas, nacionalinis identiškumas, vartotojo elgsena, kilmės šalis, Čekijos vartotojas.*

The article has been reviewed.

Received in May, 2011; accepted in June, 2012.