

## **General Disclaimer**

### **One or more of the Following Statements may affect this Document**

- This document has been reproduced from the best copy furnished by the organizational source. It is being released in the interest of making available as much information as possible.
- This document may contain data, which exceeds the sheet parameters. It was furnished in this condition by the organizational source and is the best copy available.
- This document may contain tone-on-tone or color graphs, charts and/or pictures, which have been reproduced in black and white.
- This document is paginated as submitted by the original source.
- Portions of this document are not fully legible due to the historical nature of some of the material. However, it is the best reproduction available from the original submission.

NASA Technical Memorandum 86927

(NASA-TM-86927) CONTACT ANGLE AND SURFACE  
TENSION MEASUREMENTS OF A FIVE-RING  
POLYPHENYL ETHER (NASA) 25 p HC A02/MF A01  
CSCL 11G

N85-15897

Unclas

G3/27 13459

# Contact Angle and Surface Tension Measurements of a Five-Ring Polyphenyl Ether

William R. Jones, Jr.  
*Lewis Research Center  
Cleveland, Ohio*



Prepared for the  
1985 Annual Meeting of the American Society of Lubrication Engineers  
Las Vegas, Nevada, May 6-9, 1985

**NASA**

CONTACT ANGLE AND SURFACE TENSION MEASUREMENTS  
OF A FIVE-RING POLYPHENYL ETHER

William R. Jones, Jr.  
National Aeronautics and Space Administration  
Lewis Research Center  
Cleveland, Ohio 44135

ABSTRACT

Contact angle measurements were performed for a five-ring polyphenyl ether isomeric mixture on M-50 steel in a dry nitrogen atmosphere. Two different techniques were used: (1) a tilting plate apparatus, and (2) a sessile drop apparatus. Measurements were made for the temperature range 25 to 190 °C. Surface tension was measured by a differential maximum bubble pressure technique over the range 23 to 220 °C in room air. The critical surface energy of spreading ( $\gamma_c$ ) was determined for the polyphenyl ether by plotting the cosine of the contact angle ( $\theta$ ) versus the surface tension ( $\gamma_{LV}$ ). The straight line intercept at  $\cos \theta = 1$  is defined as  $\gamma_c$ .  $\gamma_c$  was found to be 30.1 dyn/cm for the tilting plate technique and 31.3 dyn/cm for the sessile drop technique. These results indicate that the polyphenyl ether is inherently autophobic (i.e., it will not spread on its own surface film until its surface tension is less than  $\gamma_c$ ). This phenomenon is discussed in light of the wettability and wear problems encountered with this fluid.

INTRODUCTION

Polyphenyl ethers are among the most thermally and oxidatively stable organic fluids known. Therefore, they have often been considered as possible high temperature lubricants (1 and 2). However, these fluids have exhibited poor boundary lubricating characteristics in friction and wear tests (3 to 5), pump loops (6) and bearing tests (7). They are particularly poor lubricants under dry inert conditions (3, 6, 8, and 9).

In addition, an important condition in the lubrication of bearings is the distribution of lubricant near the conjunction region. The location of the lubricant boundary determines where the hydrodynamic pressure is generated. As this boundary approaches the conjunction region, lubricant starvation (10) can occur which lowers the lubricant film thickness, alters traction characteristics, and may eventually lead to bearing surface distress and failure (11). The distribution of a lubricant in a bearing can be affected by wettability (3) and surface tension (12). Therefore, the objective of this study was to determine the wettability properties of a five-ring polyphenyl ether (5P-4E) by measuring contact angles on M-50 steel as a function of temperature.

Tests were performed from 25 to 190 °C in a dry nitrogen atmosphere using a tilting plate and a sessile drop apparatus. Surface tension was measured by the maximum bubble pressure technique from 23 to 220 °C in air.

## EXPERIMENTAL MATERIALS

### Lubricant

The polyphenyl ether used in these studies was an isomeric mixture of five-ring components. This fluid contained no additives. Typical properties of this fluid appear in Table 1. Its structure is shown in Fig. 1. This fluid is the base stock for the lubricant meeting military specification MIL-L-87100 (13). It will be referred to as 5P-4E. Symbols and abbreviations appear in the appendix.

### Contact Angle Specimens

Specimens for contact angle measurements were made of CVM M-50 tool steel, having a Rockwell C hardness of 62 to 64. Specimens were ground and lapped to a surface finish of about  $10 \times 10^{-8}$  m ( $4 \mu\text{in}$ )  $R_a$ . This particular material was chosen because it is the most common material for making balls and races of high temperature bearings.

## APPARATUS

### Surface Tension

A differential maximum bubble pressure apparatus was used to measure surface tension as a function of temperature. It is shown schematically in Fig. 2.

The apparatus consists of two parts. The lower part is a heat-resistant glass tube which acts as a reservoir for the test fluid. The upper part contains two capillary tubes and one open tube. It is sealed to the lower part by a ground-glass joint. The two capillary tubes are of the same length but different diameters, and both may be opened or closed with stopcocks. The capillary diameters are approximately 1 and 0.02 mm. The open tube is connected to a 2000 cm<sup>3</sup> flask which acts as a pressure damping device. The flask is connected to a vacuum line and a differential strain-gage pressure transducer. This transducer measures the differential pressure between the test chamber and the ambient room pressure. The bubble apparatus is placed in a constant-temperature circulator containing glycerol as the heat-transfer fluid. Temperature control in the circulator is specified to be  $\pm 0.01$  °C from 40 to 200 °C. However, because of the high viscosity of the glycerol, temperature control is poorer from 40 to 80 °C.

### Contact Angle

Two different techniques were used to measure contact angle as a function of temperature (1) a tilting plate apparatus, and (2) a sessile drop apparatus.

The tilting plate apparatus is shown schematically in Fig. 3. It consists of a stainless steel fluid reservoir (~0.5 l) and a small M-50 steel plate (4.1x1.3x0.24 cm) which can dip into the liquid in the reservoir at various angles. The plate is attached to a lever arm which is rotated at slow speed by a motor. The reservoir and plate are contained in a chamber for atmosphere control. Contact angles are measured with a goniometer through a

side window. The fluid is heated by a variable resistance heater located in the base of the reservoir. Temperature is monitored by a thermometer immersed in the fluid.

A sessile drop apparatus was also used to measure contact angles. This apparatus is shown in Fig. 4. It consists of a low power microscope for horizontal observation of a fluid drop. A drop is placed on the test specimen which is in turn placed on a heated platen. A light source allows for back illumination of the drop. A cover allows for atmosphere control. Specimen temperature is sensed by a contact thermocouple and maintained by a temperature controller. Contact angles are measured by a goniometer eyepiece.

#### PROCEDURE

##### Surface Tension Apparatus

The bubble apparatus is cleaned in hot chromic acid solution and rinsed with tap water and then with distilled water. Approximately  $100 \text{ cm}^3$  of test fluid ( $1 \times 10^{-4} \text{ m}^3$ ) are placed in the reservoir. The test fluid itself acts as a lubricant for the ground-glass joint. The apparatus is placed in the circulator, and the desired temperature is set. Then 10 to 15 min are allowed for temperature equilibrium to be established.

The large capillary tube is opened, and a slight vacuum is pulled in the test chamber. The pressure differential across the chamber causes air to be drawn through the capillary and results in the formation of a stream of bubbles. The pressure is regulated so that one or two bubbles a second are formed. The differential pressure rises to a maximum as the bubble is being formed and drops sharply as the bubble breaks away from the capillary tip and travels to the surface. Then the pressure differential increases again and the process is repeated. These pressure changes are recorded on an x,y-recorder. A schematic of a typical recorder trace appears in Fig. 5.

After several pressure spikes have been recorded for the large capillary, the small tube is opened and the large tube is closed. The procedure is repeated. The smaller capillary, of course, requires a greater pressure difference for bubble formation. The manner of bubble formation is also different. The pressure difference rises to a maximum, and then a stream of bubbles appears. This process decreases the pressure difference, and bubble formation stops. The pressure difference increases again, and the process is repeated. A recorder trace for this behavior also appears in Fig. 5.

#### Calculation of Surface Tension

The surface tension is calculated by using the equation developed by Sudgen (14):

$$\gamma_{LV} = AP\varphi \quad (1)$$

where  $A$  is the apparatus constant,  $P$  is the pressure difference between the two capillaries ( $H_1 - H_2$ , from Fig. 5) in newtons per square centimeter, and  $\varphi$  is a correction factor, which is given by the following equation:

$$\varphi = 1 + \frac{0.69 r_2 g D}{p} \quad (2)$$

The apparatus constant is determined by using distilled water as the calibrating fluid. The constant  $A$  for the apparatus was determined by this method to be  $3.32 \times 10^{-3}$  cm. To check the accuracy of this constant, the surface tension as a function of temperature was determined for two other pure compounds, benzene, and bromobenzene. Both were of reagent grade purity. The benzene and bromobenzene surface tensions were compared to literature values, and a maximum error of 1.9 percent and an average error of less than 1.0 percent were obtained.

#### Tilting Plate Apparatus

The fluid reservoir and M-50 steel plate were thoroughly cleaned by scrubbing with a paste of levigated alumina and water, rinsed with tap water

and finally distilled water and allowed to air dry. The plate was then positioned in the chamber. Approximately 0.5 l of polyphenyl ether was thoroughly degassed by heating to 150 °C under a vacuum. The degassed fluid was transferred to the reservoir after the chamber had been purged for 30 min with dry nitrogen. A continuous nitrogen purge was maintained during the test. The reservoir heater was set for the proper fluid temperature. After temperature stabilization, the plate was tilted so that the fluid recedes off the plate and a curved meniscus formed. The plate is continuously rotated at slow speed (~1 rpm) until the meniscus becomes straight as it contacts the plate. At this point, the angle of the plate is measured with a goniometer. Then the temperature is increased (normally 25 °C), allowed to stabilize, and the procedure repeated. Only advancing angles were measured.

#### Sessile Drop Apparatus

For tests with this apparatus, the M-50 steel plate was cleaned as previously described. It was then placed on the platen and the cover closed. A nitrogen flow is maintained over the specimen. Several drops of degassed polyphenyl ether were placed on the specimen through a port in the top of the cover. This was accomplished by dipping a flamed platinum wire in the degassed lubricant and touching the plate. Drop size varied but typically was in the range of 0.5 to 1.5 ul.

The light source and microscope stage were then adjusted to produce a sharp silhouette of the drop. Then a goniometer eyepiece was used to measure the contact angle as illustrated in Fig. 6. The temperature was then increased by 5 °C and the measurement repeated.

## RESULTS

### Surface Tension

Surface tension as a function of temperature for 5P-4E, measured by the maximum bubble pressure technique, appears in Fig. 7. A maximum value of



46 dyn/cm was obtained at 23 °C. The surface tension then decreases linearly with increasing temperature which occurs with most organic liquids (15). A temperature coefficient of surface tension ( $d\gamma/dT$ ) of 0.088 dyn/cm C was obtained.  $\gamma_{LV}$  at 23 °C and  $d\gamma/dT$  for a series of other liquid lubricants appear in Table 2 for comparison.

#### CONTACT ANGLES

Contact angles for various temperatures for 5P-4E using both test devices appear in Table 3. Values range from a high contact angle of 50° at 70 and 90 °C for the plate apparatus to a low contact value of 5° at 180 °C for the sessile drop technique. Values for the plate apparatus are consistently higher than from the sessile drop measurements. There is no apparent reason for these differences, other than that two completely different techniques were used. Reproducibility of contact angles at any particular condition was about  $\pm 2^\circ$ . Error in angle measurement using a goniometer is considered to be  $\pm 1^\circ$ . These variations are similar to those reported in the literature (16 and 17).

#### DISCUSSION

When a liquid forms a finite contact angle on a surface ( $\theta \neq 0$ ), we say the liquid is nonspreading. If the contact angle is zero, the liquid wets the surface completely and spreads freely over the surface at a rate depending on viscosity and surface roughness.

At room temperature, the surface-free energies of organic liquids and lubricants are less than 100 ergs/cm<sup>2</sup>. Metals have surface-free energies ranging from 500 to 5000 ergs/cm<sup>2</sup>. Theoretically, one would then expect all organic liquids to spread freely on any high energy solid. This is because the spreading would result in a large decrease in the free energy of the system.

If one considers low energy solids such as polymers, the situation could, and does, exist where the surface energy (surface tension) of a fluid is greater than that of the surface. For that situation, the fluid would not spread and a drop having a finite contact angle would occur. An analogous situation could occur if low energy contaminant films are present on the high energy solid surface (16).

Considering the materials in this study, 5P-4E and M-50 steel, one would predict that this fluid type should spread freely on a clean M-50 surface. However, it has been well documented (3, 6, and 8) that this does not always occur. Another class of chemically similar fluids, the C-ethers, have exhibited similar wetting problems (6 and 18). This nonspreading phenomenon occurred in spite of procedures to remove polar impurities which might have produced oleophobic films.

Many years ago, Hare and Zisman (19) reported similar nonwetting properties for certain pure organic fluids such as 1-octanol, trichlorodiphenyl, and tri-o-cresyl phosphate. It was hypothesized that these fluids were nonspreading because the molecules adsorbed on the solid surface formed a film whose critical surface energy was less than the surface tension of the fluid itself. Hare and Zisman coined a term "autophobic liquids" to describe this behavior.

Since two of the fluids mentioned by Hare and Zisman were aromatic and thus were chemically somewhat similar to the aromatic polyphenyl ether (5P-4E), it seemed plausible that 5P-4E may also be autophobic.

To check this possibility, two things are needed: surface tension as a function of temperature and the critical surface energy of spreading,  $\gamma_c$ . The surface tension for 5P-4E is easily measured and appears in Fig. 7 for temperatures from 23 to 220 °C.

The critical surface energy of spreading,  $\gamma_c$ , of an adsorbed monolayer is more difficult to measure. The classical technique to measure  $\gamma_c$  for low energy polymer surfaces is to plot the cosine of the contact angle ( $\cos \theta$ ) for a homologous series of organic liquids as a function of their surface tension ( $\gamma_{LV}$ ). Empirically, a rectilinear relationship was established. The  $\gamma_c$  was defined by the intercept of the horizontal line  $\cos \theta = 1$  with the extrapolated straight line plot of  $\cos \theta$  versus  $\gamma_{LV}$ . A typical plot for the wettability of polytetrafluoroethylene (PTFE) by a series of n-alkanes appears in Fig. 8 (16). This yields a  $\gamma_c$  for PTFE of approximately 18.5 dyn/cm at 20 °C. Essentially, this means that, at 20 °C, a n-alkane having a surface tension >18.5 dyn/cm will not spread on a PTFE surface. On the other hand, a n-alkane with a surface tension <18.5 dyn/cm or less will spread spontaneously.

To determine the  $\gamma_c$  of an adsorbed surface film, a modification of this technique can be used. If one were to use a series of organic liquids of varying surface tensions, the possibility exists for chemical or physical interaction with the adsorbed surface film. This could alter the wetting properties of the surface.

Another way to determine  $\gamma_c$  for the surface film would be to measure contact angle as a function of temperature. As temperature varies, the surface tension varies and an analogous plot of  $\cos \theta$  versus  $\gamma_{LV}$  could be plotted for one fluid. One problem using this procedure is that  $\gamma_c$  can also change with temperature. Surface film density will decrease with increasing temperature. However, this effect is not great and  $\gamma_c$  will increase only slightly as temperature rises (16).

A second consideration is the possibility of lubricant and metal oxidation and lubricant degradation at high temperatures. The contact angle measurements were all performed in a nitrogen atmosphere to preclude any

oxidation problems. Surface tension measurements were made in air. This, in part, was done because of experimental difficulties involved in supplying nitrogen to the bubble pressure apparatus. However, it is not felt that an air atmosphere presented any problems for these tests. 5P-4E is oxidatively stable at the highest temperature (220 °C) reached in the surface tension measurements.

Therefore, the contact angle data from Table 2 has been plotted in the standard  $\cos \theta$  versus  $\gamma_{LV}$  format. The data for the tilting plate apparatus appears in Fig. 9 and for the sessile drop apparatus in Fig. 10. A least squares technique was used to determine the best straight line for each set of data. Extrapolated to  $\cos \theta = 1$ ,  $\gamma_c$  was determined to be 30.1 dyn/cm for the tilting plate technique and 31.3 dyn/cm for the sessile drop technique. This is good agreement considering that two completely different techniques were used.

These values indicate that the polyphenyl ether will not spread on its own surface film until its surface tension falls below about 30 to 31 dyn/cm. This surface tension corresponds to a fluid temperature of approximately 190 to 200 °C.

Therefore, 5P-4E is inherently nonspreading on steel surfaces over most of its practical temperature range. This fact may contribute to some of the wear problems (8) associated with this fluid. This may partially explain the order of magnitude drop in wear that occurs at temperatures above 200 °C, as shown in Fig. 11 for a dry nitrogen atmosphere. A similar drop in wear occurs above 100 °C for dry air but here oxidation effects on the metal surface may come into play. It seems likely that the C-ethers are also autophobic. Chemically, the C-ethers are very similar to the polyphenyl ethers since they

are mixtures of thiophenyl ethers. Thus, the wetting problems associated with this fluid (6 and 13) may be explained by a similar phenomenon. Preliminary contact angle measurements of C-ethers on steel support this supposition.

It should be noted that additives can alter the chemistry of absorbed surface films and thus their wetting characteristics. Some studies along this line have been reported (3).

#### SUMMARY OF RESULTS

A tilting plate and a sessile drop technique were used to determine contact angles of a five-ring polyphenyl ether (5P-4E) on M-50 steel in dry nitrogen. A maximum bubble pressure technique was used to determine surface tension. The major results were:

1. The critical surface energy of spreading ( $\gamma_c$ ) was determined to be 30.1 and 31.3 dyn/cm from the tilting plate and sessile drop techniques, respectively.

2. It was concluded that 5P-4E is inherently autophobic (i.e., it is unable to spread on its own surface film.)

3. This phenomenon is discussed in light of the wettability and wear problems encountered with this fluid.

APPENDIX - SYMBOLS

A	bubble-pressure apparatus constant, cm
D	liquid density, g/cm <sup>3</sup>
g	acceleration due to gravity, 981 cm/s <sup>2</sup>
H	H <sub>1</sub> - H <sub>2</sub> , N/cm <sup>2</sup>
H <sub>1</sub>	differential pressure for bubble evolution from small capillary, N/cm <sup>2</sup>
H <sub>2</sub>	differential pressure for bubble evolution from large capillary, N/cm <sup>2</sup>
P	pressure, N/cm <sup>2</sup>
r <sub>2</sub>	large capillary radius, mm
γ <sub>LV</sub>	surface tension, N/cm; dyn/cm
φ	correction factor, $1 + \frac{0.69r_2gD}{p}$ , dimensionless
γ <sub>c</sub>	critical surface energy of spreading, dyn/cm
5P-6E	five-ring polyphenyl ether
$\frac{d\gamma_{LV}}{dT}$	temperature rate of change of surface tension, dyn/cm-C°
PTFE	polytetrafluoroethylene
C-ether	thiophenyl ether

## REFERENCES

1. Gunderson, R.C., and Hart, A.W., eds., Synthetic Lubricants. Reinhold Publishing Corp., 1962.
2. Mahoney, G.L., Barnum, E.R., Kerlin, W.W., and Sax, K.J., "Meta-Linked Polyphenyl Ethers as High-Temperature Radiation-Resistant Lubricants," ASLE Trans., 3, (1) 83-92 (1960).
3. Jones, W.R., Jr., and Hady, W.F., "Effect of Humidity and a Wettability Additive on Polyphenyl Ether Boundary Lubrication of Steel in Air and Nitrogen to 350 °C," NASA TN D-6055, 1970.
4. Spar, C., and Damasco, F., "High-Temperature Fluid Lubrication," ASLE Trans., 7, (2) 211-217 (1964).
5. Montgomery, R.S., "Lubrication of Bearing Aluminum With Polyphenyl Ethers," Wear, 14, 213-217 (1969).
6. Jones, W.R., Jr., Hady, W.F., and Swikert, M.A., "Lubrication With Some Polyphenyl Ethers and Superrefined Mineral Oils in a 600 °F (316 °C) Inerted Vane Pump Loop," NASA TN D-5096, 1969.
7. Bamberger, E.N., Zaretsky, E.V., and Anderson, W.J., "Effect of Three Advanced Lubricants on High-Temperature Bearing Life," J. Lubr. Technol., 92, (1) 23-33 (1970).
8. Jones, W.R., Jr., "The Effect of Oxygen Concentration on the Boundary Lubricating Characteristics of a C-Ether and a Polyphenyl Ether to 300 °C," Wear, 73, 123-136 (1981).
9. Jones, W.R., Jr., "Ferrographic Analysis of Wear Debris from Boundary Lubrication Experiments with a Five-Ring Polyphenyl Ether," NASA TN D-7804, 1974.
10. Wedeven, L.D., Evans, D., and Cameron, A., "Optical Analysis of Ball Bearing Starvation," J. Lubr. Technol., 93, (3) 349-363 (1971).

11. Wedeven, L.D., "Traction and Film Thickness Measurements Under Starved Elastohydrodynamic Conditions," J. Lubr. Technol., 97 (2) 321-329 (1975).
12. Prah1, J.M., and Hamrock, B.J., "The Mechanics of a Gaseous Film Barrier to Lubricant Wetting of Elastohydrodynamically Lubricated Conjunctions, paper presented at the 11th Leeds-Lyon Symposium on Tribology, Leeds, U.K., Sept. 4-7, 1984.
13. "Lubricating Oil, Aircraft Turbine Engine, Polyphenyl Ether Base," Military Specification, MIL-L-87100 (USAF), 12 Nov. 1976.
14. Sugden, S., "Determination of Surface Tension From Maximum Pressure in Bubbles," J. Chem. Soc., 121, (1), 858-866 (1922).
15. Adamson, A.W., Physical Chemistry of Surfaces, Second edition, Interscience Publishers, 1967, pp. 54-56.
16. Zisman, W.A., "Relation of the Equilibrium Contact Angle to Liquid and Solid Constitution," Contact Angle, Wettability, and Adhesion, R.F. Gould, ed., American Chemical Society, 1964, pp. 1-15.
17. Fox, H.W., and Zisman, W.A., "The Spreading of Liquids on Low-Energy Surfaces. III Hydrocarbon Surfaces," J. Colloid. Sci., 7, 428-442 (1952).
18. Shim, J., and Leonard1, S.J., "Microfog Lubricant Application System for Advanced Turbine Engine Components, Phase II: Tasks 1 and 2: Wettabilities of Microfog Streams of Various Lubricants and Optimization of Microfog Lubrication," NASA CR-72743, 1970.
19. Hare, E.F., and Zisman, W.A., "Autophobic Liquids and the Properties of Their Adsorbed Films," J. Phys. Chem., 59, (4) 335-340 (1955).



TABLE 1. - SOME PROPERTIES OF A FIVE-RING POLYPHENYL ETHER

Kinematic viscosity, m <sup>2</sup> sec (cS)	
at 38 °C (100 °F)	3.6x10 <sup>-4</sup> (360)
at 99 °C (210 °F)	1.3x10 <sup>-5</sup> (13)
at 350 °C (662 °F)	7.2x10 <sup>-7</sup> (0.72)
Pour point, °C (°F)	5 (40)
Flash point, °C (°F)	288 (550)
Fire point, °C (°F)	350 (662)
Density at 38 °C (100 °F), kg/m <sup>3</sup> (g/ml)	1.19x10 <sup>3</sup> (1.19)
Thermal decomposition (isoteniscope), °C (°F)	443 (830)
Vapor pressure at 343 °C (650 °F), torr	12
Surface tension at 25 °C (77 °F), N/cm (dyn/cm)	5x10 <sup>-4</sup> (50)

TABLE 2. - SURFACE TENSION AT 23 °C AND TEMPERATURE COEFFICIENT OF SURFACE TENSION FOR SEVERAL LIQUID LUBRICANTS

Test lubricant	Temperature coefficient of surface tension, -dγ <sub>L</sub> /dt, N/(cm)(°C)	Surface tension at 23 °C	
		N/cm	dyn/cm
Five-ring polyphenyl ether	0.088x10 <sup>-5</sup>	46.0x10 <sup>-5</sup>	46.0
Four-ring polyphenyl ether	.088	44.8	44.8
Modified polyphenyl ether (C-ether)	.088	44.8	44.8
Synthetic paraffinic oil	.064	30.3	30.3
Superrefined naphthenic mineral oil	.064	30.3	30.3
Superrefined paraffinic mineral oil	.077	29.8	29.8
Fluorosilicone	.063	25.0	25.0
Fluorinated polyether	.053	17.3	17.3

TABLE 3. - CONTACT ANGLES FOR A FIVE-RING POLYPHENYL ETHER ON M-50 STEEL AT VARIOUS TEMPERATURES IN A DRY NITROGEN ATMOSPHERE

Temperature, °C	Contact angle, deg	
	Tilting plate apparatus	Sessile drop apparatus
25	-----	30,32,34
50	-----	27,27,29
70	47,50	-----
75	-----	24,24,27
80	40	-----
90	50	-----
100	40,42	22,23,24
110	37,38	-----
115	41	-----
120	33,36	-----
125	-----	19,20,22
130	29,33	-----
140	31,36	-----
145	37	-----
150	29,34	15,16,17
155	34	-----
160	27,28	-----
165	31	-----
170	22,27	-----
175	24	7,9,11
180	18,20	5,5,11
185	20	-----
190	22	-----

ORIGINAL PAGE IS  
OF POOR QUALITY

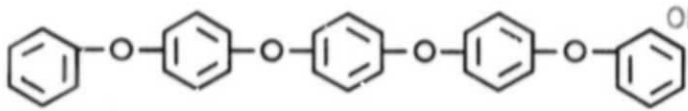

MIX - BIS (MIX - PHENOXYPHENOXY) BENZENE

Figure 1. - Experimental lubricant structure of five ring polypheny ether (5P-4E).

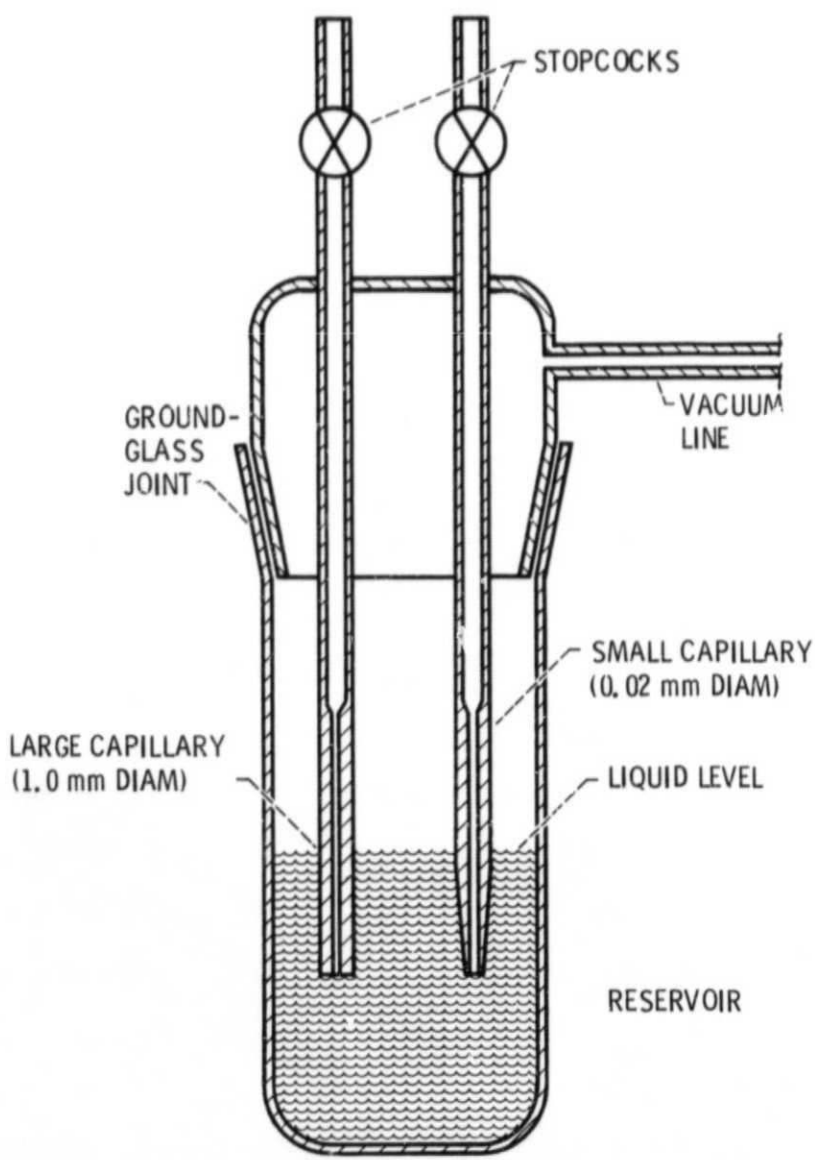

Figure 2. - Surface tension apparatus (maximum bubble pressure).

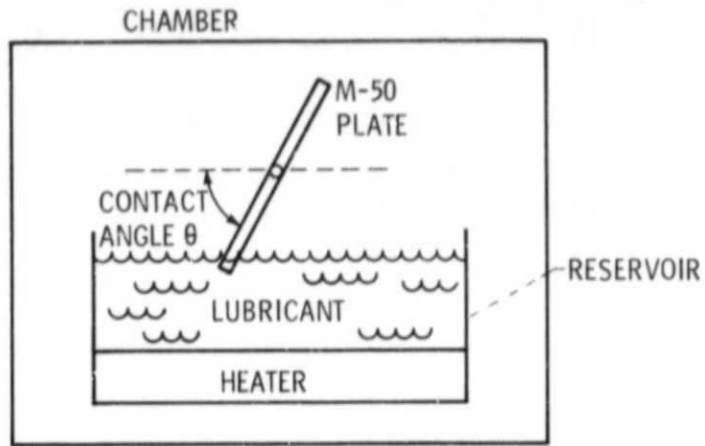

Figure 3. - Schematic diagram of tilting plate contact angle device.

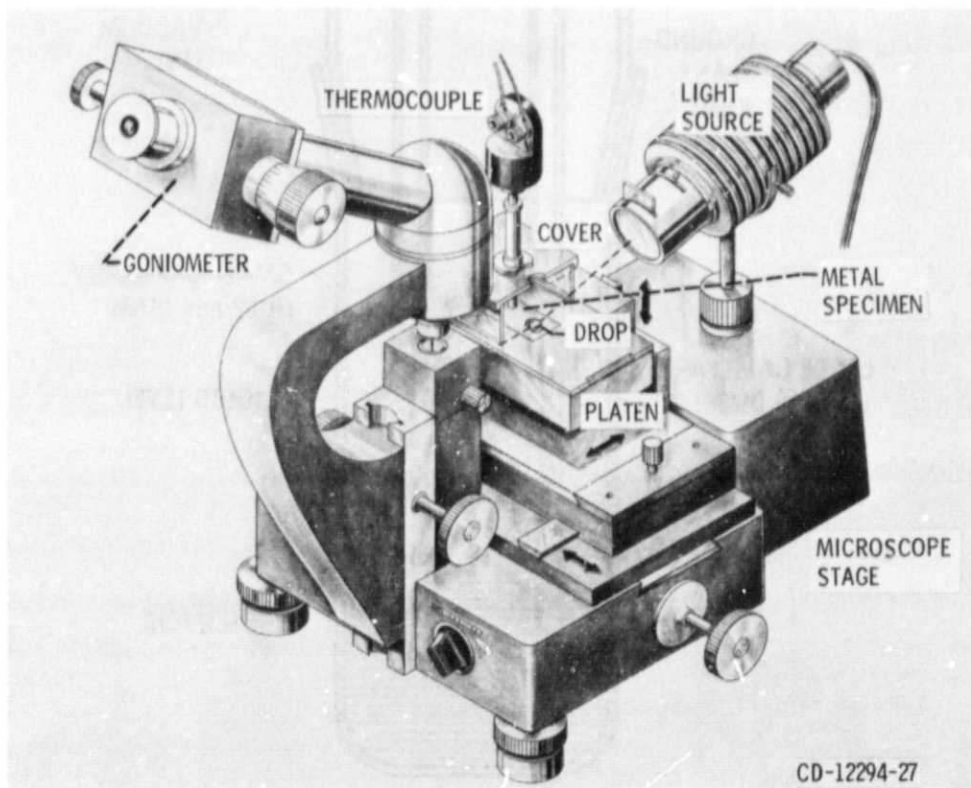

Figure 4. - Sessile drop contact angle apparatus.

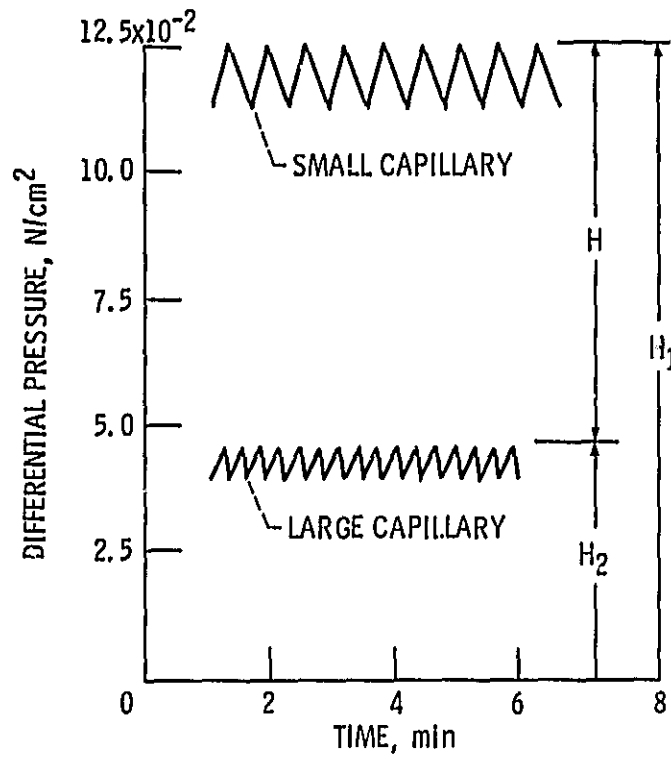

Figure 5. - Typical differential pressure measurements for large and small capillary tubes from maximum bubble pressure apparatus.

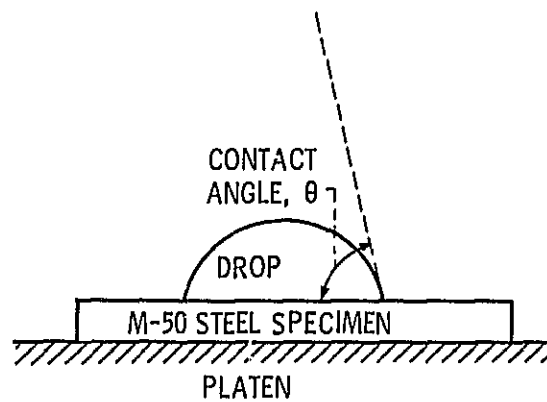

Figure 6. - Representation of contact angle measurement from sessile drop apparatus.

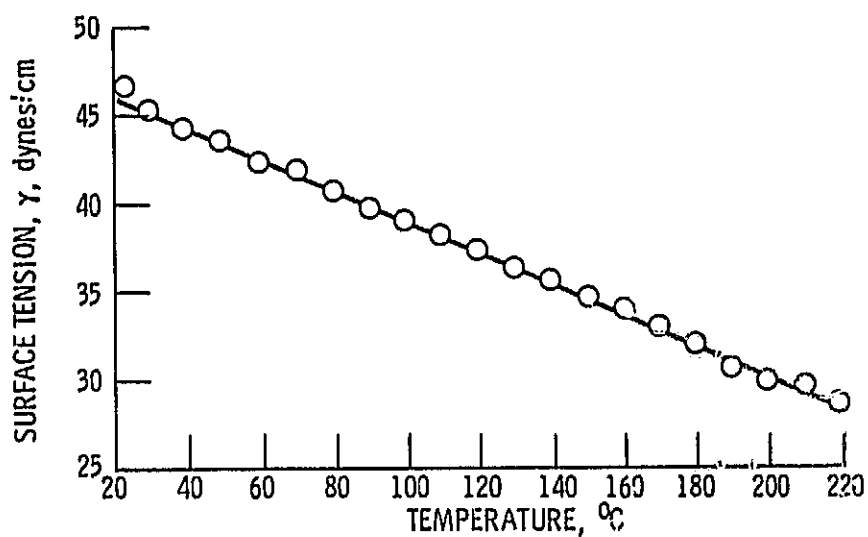

Figure 7. - Surface tension as a function of temperature for a five ring polyphenyl ether (5P-4E) using the maximum bubble pressure technique.

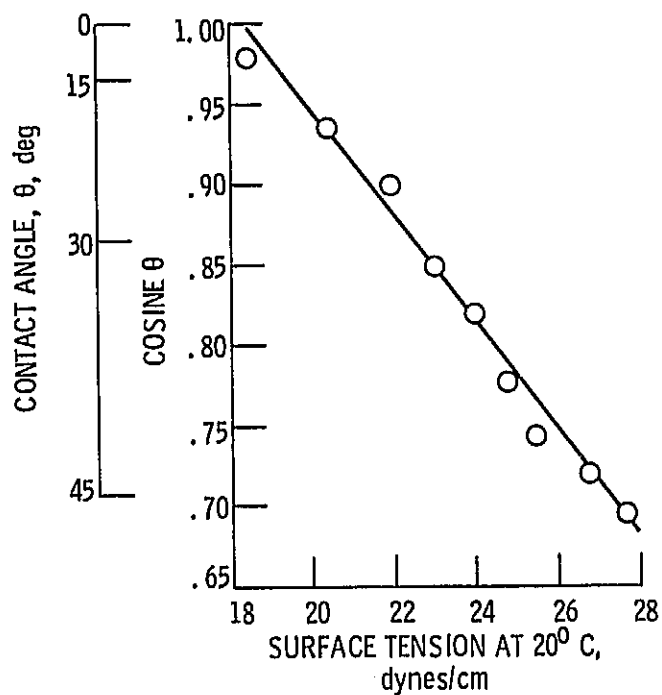

Figure 8. - Wettability of polytetrafluoroethylene by n-alkanes (from ref. 12).

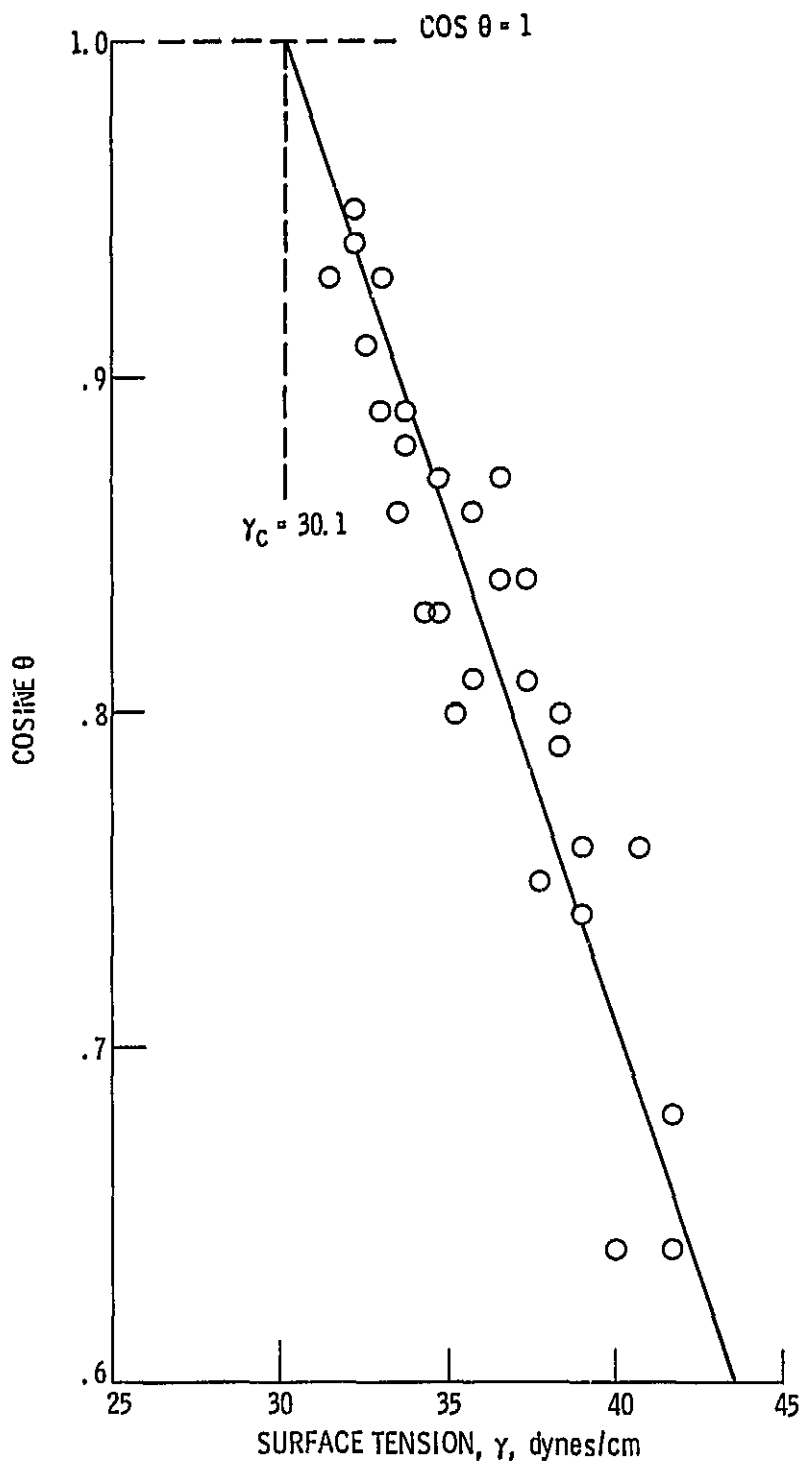

Figure 9. - Cosine of the contact angle of 5P-4E on M-50 steel as a function of surface tension - tilting plate apparatus (dry nitrogen atmosphere).

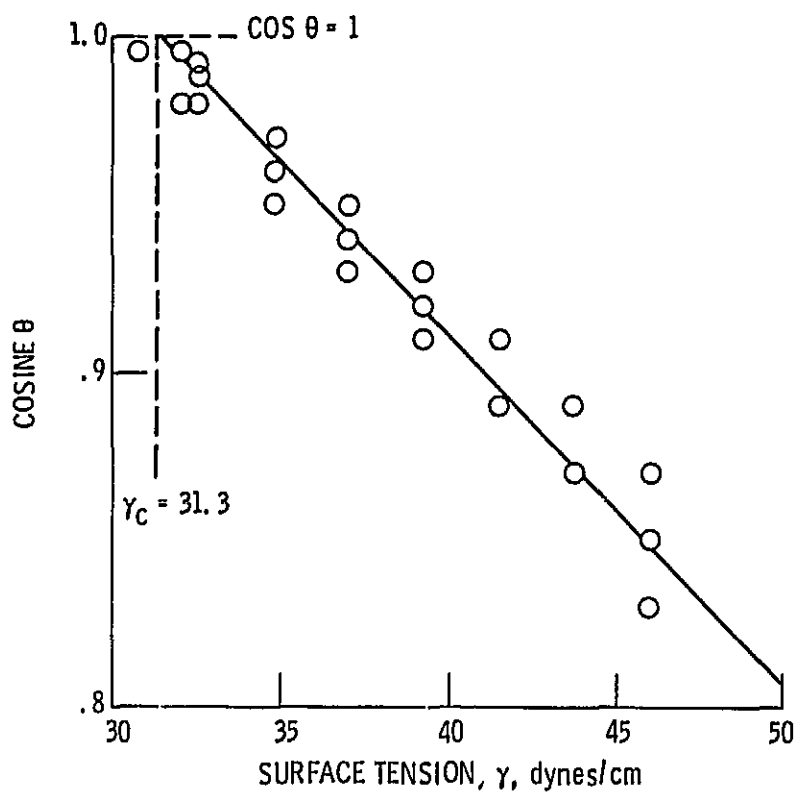

Figure 10. - Cosine of the contact angle of 5P-4E on M-50 steel as a function of surface tension - sessile drop apparatus (dry nitrogen atmosphere).



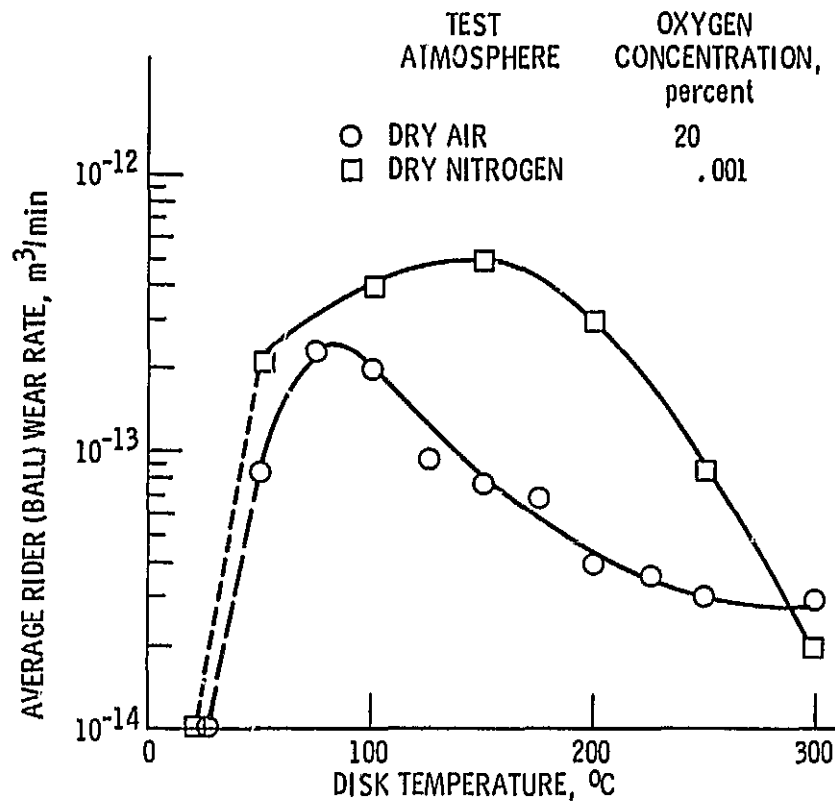

Figure 11. - Average rider wear rate as a function of temperature for a five ring polyphenyl ether in atmospheres with two oxygen concentrations. (specimen material, M-50 steel; 1 kg load; sliding speed, 17 m/min; test duration, 25 min) (from ref. 8).