

CONTINUOUS ASSESSMENT OF A DRINKING WATER PVC PIPE

A. M. Arsénio^{1,2}, J. H. G. Vreeburg^{1,2}, M. P. C. Wielinga³, J. C. van Dijk²

1. KWR – Watercycle Research Institute, Nieuwegein, the Netherlands, andre.arsenio@kwrwater.nl, jan.vreeburg@kwrwater.nl

2. Technische Universiteit Delft, Delft, the Netherlands, j.c.vandijk@tudelft.nl

3. PWN Waterleidingbedrijf Noord-Holland, Velsbroek, the Netherlands, marcel.wielinga@pwn.nl

INTRODUCTION

In 2010 the Dutch drinking water network stretched for almost 116,000 km supplying water to more than 16 million people. Almost 50% was made of PVC. The analysis of the failure registration of 5 Dutch drinking water companies showed that ca. 29 % of the total number of failures in the PVC Dutch network is detected at joints. In the Netherlands, the PVC joints are single pieces with two rubber rings. This system is used instead of the bell-and-spigot and allows more rotation on the joint.

The present work discusses the installation of sensors for real-time monitoring of a newly installed PVC pipe that serves ca. 1250 customers. The objectives are:

- Study of influence of environmental factors in the behaviour of the pipe and joints: effect of seasonal changes in soil temperature, soil moisture and soil pressure on the stress that is applied on the pipe,
- Monitor a pipe that will also be inspected in different occasions. The results of this condition assessment will be compared with the results of the real-time monitoring. This will be used to validate the pipe monitoring with visual condition assessment.

METHODOLOGY

Location and setup

The pipe is located in the region of North Holland (the Netherlands). The instrumented pipe is newly installed DN250 biaxial PVC with 10 m pipe sections. The pipe sections are connected using non-restrained joints. The installation of the sensors was performed on the 27 September 2011. All sensors were placed while the pipe was being installed. The objective is studying the way the pipe reacts to environmental and operational changes.

The environmental changes will be monitored with thermistors (soil temperature), water content reflectometers (soil moisture content) and earth pressure cells (soil pressure). The reaction of the pipe and joints will be monitored with strain gauges. For this, three joints and four pipe barrels in a row are instrumented with strain gauges:

- Location I: pipe A, joint 1 and point B,
- Location II: point C, joint 2 and point D,
- Location III: point E, joint 3 and point F.

Thermistors were installed at each location to monitor the soil's temperature during the monitoring period. Water content reflectometers (WCR) are used to determine soil's moisture content at each location. Thermistors and WCR were installed 50 cm next to each joint (Figure 1). Soil pressure cells have also been installed 50 cm below each one of the three joints (Figure 2).

Axial strain gauges were installed to monitor the expansion and contraction of the PVC pipes and joints. Expansion and contraction occurs either due to environmental or operational changes. A scheme with the locations of the installed strain gauges at location I is given on Figure 3. This setup is equivalent for locations II and III.

All sensors were tested in the laboratory before installation. A complete list of the installed sensors (per monitoring location) is given on Table 1.

Condition assessment of the pipe

The pipe was inspected on 27 January 2012 using closed-circuit television. At each joint the gap width (distance between the two pipes inside the joint) was measured at four locations: crown (12 h), invert (6 h) and both springlines (3 h and 9 h). The inspection was duplicated and results of the two runs (run 1 and run 2) are presented in Figure 4. This was the first of a set of inspections that are planned to be performed throughout 2012 on this pipe. This set of inspections will be used to validate the results of the pipe monitoring.

RESULTS

- Results for location II are given in Figure 5. Point C is located 7 cm before the joint and point D is located 7 cm after the joint. Joint 2 is the monitoring point on the joint's outer wall. The setup is similar to the one presented in Figure 3. On the X-axis is given the date, on the left Y-axis is given soil temperature and on the right Y-axis is given average axial strain (microstrain) recorded on the outer joint and pipe walls. The date of the equipment's installation, the date when the pipe started to be used and a day when a valve on the pipe was used are highlighted on the plot.
- The analysed data shows that the strain gauges, can detect daily variations in strain related to water demand patterns, water pressure fluctuations and environmental variations.
- In fact, for example, with an increase of the temperature the pipe will expand (increase of strain), and the opposite occurs with a decrease of the temperature (decrease of strain), that can be easily detected from the presented data.
- The results from the CCTV inspection are given on Figure 4. On the x-axis is given axial location inside the pipe. On the y-axis is given the angle between the two pipes determined inside the joint. This angle was determined using the gap widths at the top (12 h) and bottom (6 h) of the pipe obtained from CCTV and the following formula:

$$\text{angle}_{12h-6h} = 2 \times \arcsin \left(\frac{\text{gap width}_{12h} - \text{gap width}_{6h}}{2 \text{ Pipe diameter}} \right)$$

- These results show that the installation procedure was correctly performed as far as pipe alignment is concerned. In fact, no extreme joint angle was detected.
- The reproducibility of CCTV inspection's can be discussed considering that, for some of the inspected joints, the results of both inspections differ significantly.

TABLES AND FIGURES

Table 1 – List of installed sensors at each location

Type of sensor	Supplier	Model	Amount	Data	Location
Strain gauges	Geokon	VK-415	12	Axial strain	4 gauges on the pipe immediately before the joint at 12h, 3, 6h and 9h, 7cm away from the beginning of the joint 4 gauges on the joint also at 12h, 3, 6h and 9h exactly at the centre of the joint, 4 gauges on the pipe wall at 12h, 3, 6h and 9h, 7cm away from the end of the joint.
Dummy strain gauges	Geokon	VK-415	1	Axial strain	One next to the pipe
Thermistor	Campbell Scientific	107	1	Temperature	One next to the pipe
Water content reflectometer	Campbell Scientific	CS616	1	Moisture content	One next to the pipe
Earth pressure cells	Geokon	4800	1	Soil pressure	One 50 cm below the joint

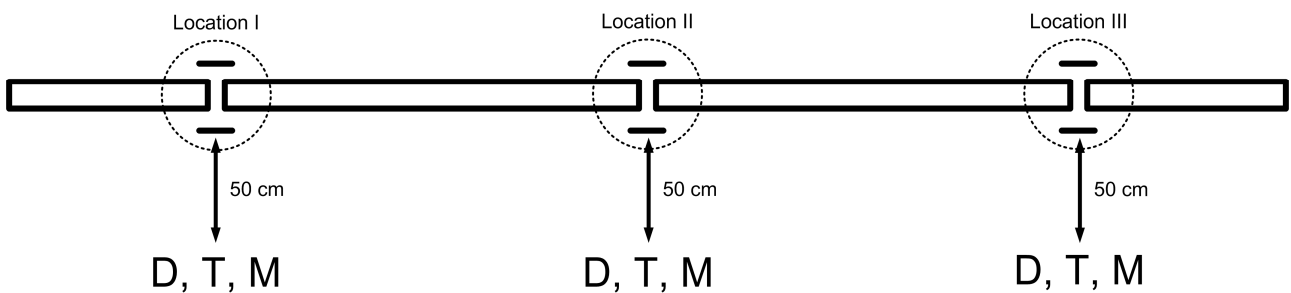

Figure 1- Top view of the monitoring setup. Each pipe section has a length of 10 m. D=dummy strain gauge. T=thermistor. M= Water content reflectometer. Image not to scale.

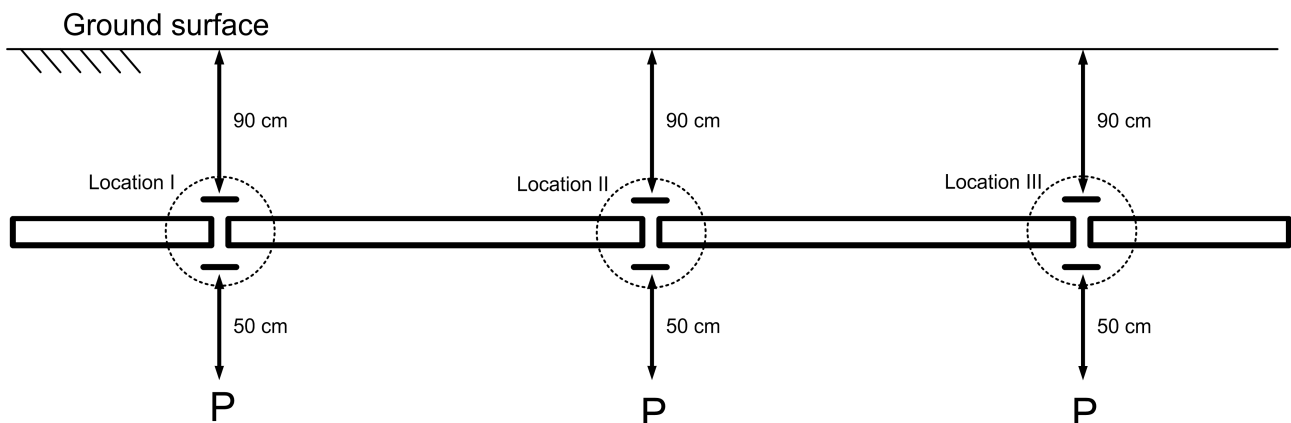

Figure 2- Side view of the monitoring setup. Each pipe section is 10 m long. P=earth pressure cells. Image not to scale.

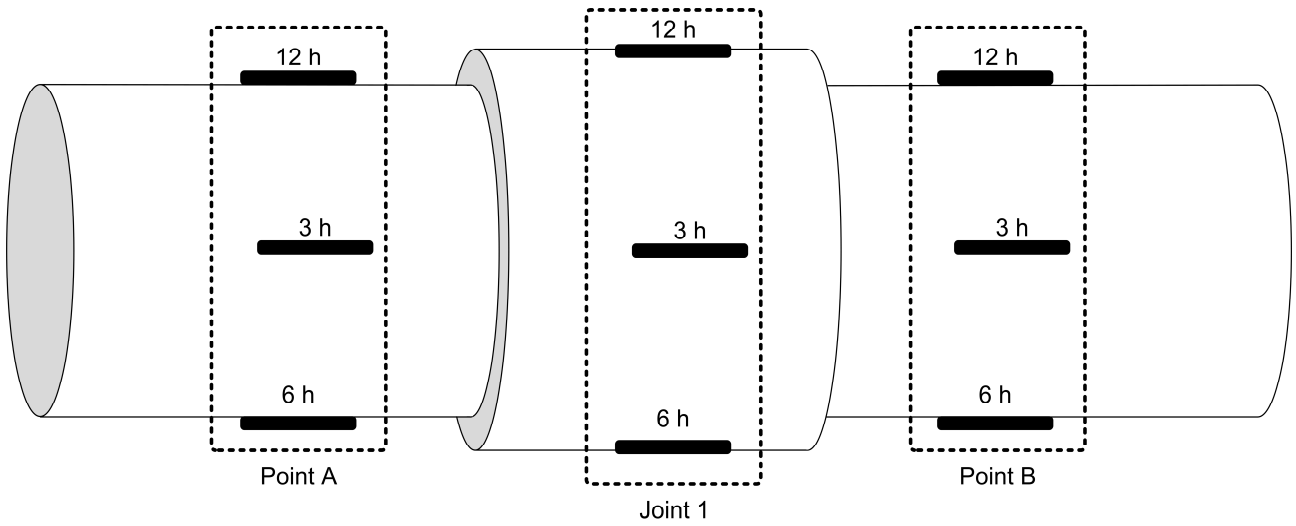

Figure 3 – Scheme of the installed strain gauges on location I. The thick horizontal black-bars represent the strain gauges. The strain gauges at points A and B were installed 7 cm away from the joint. The strain gauges installed on the joint were installed exactly on the middle. In the scheme, the strain gauges installed at 9h are on the other side of the pipe. The setup is equivalent for locations II and III. Image not to scale.

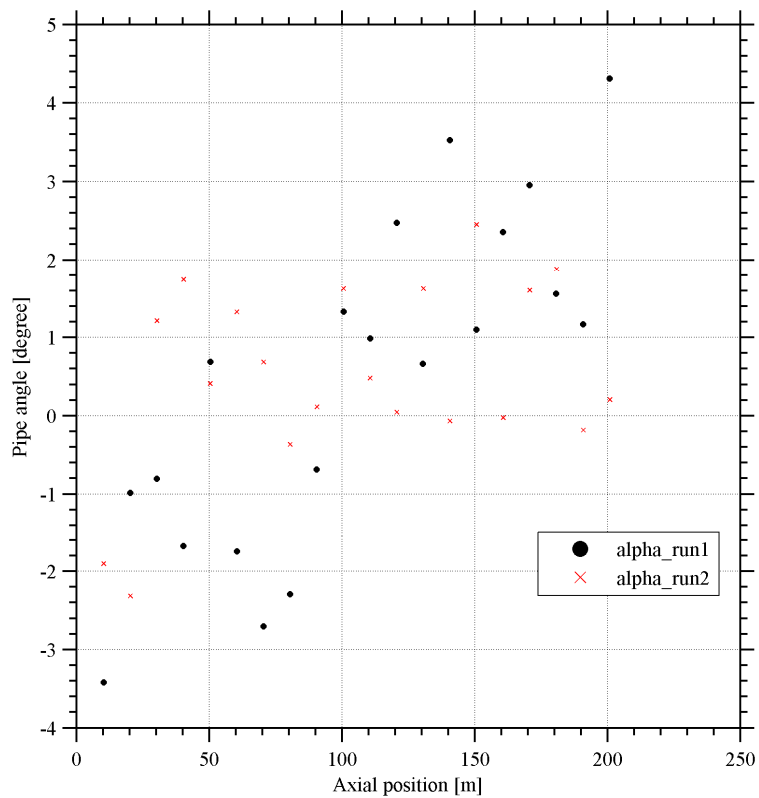

Figure 4 – Results of the CCTV inspections. On the x-axis is given axial location inside the pipe (m). On the y-axis is given pipe angle inside the joints (degree). Only angles calculated from the measured gaps for the pipe's invert and crown are presented (alpha). The inspection was duplicated (run 1 and run 2). A negative angle indicates that the gap at the pipe's invert is wider than the gap at the pipe's crown.

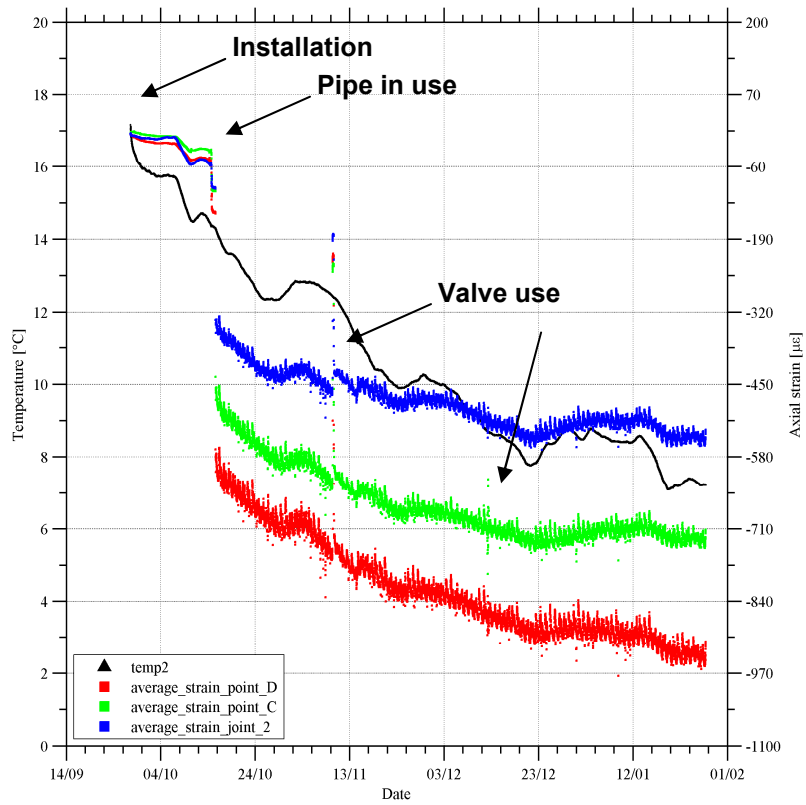

Figure 5 – Data from location II: average axial strain at points D, C and joint 2 together with temperature from thermistor installed next to joint 2.