

Control and Adjustment of Linear Induction Motor Starting Force

A. J. Poška, Z. Savickienė, A. Šlepikas

*Department of Automation, Vilnius Gediminas Technical University,
 Naugarduko str. 41, LT-03227 Vilnius, Lithuania, phone: +370 5 2744763, e-mail: algimantas.poska@el.vgtu.lt,
 zita.savickiene@el.vgtu.lt, alvydas.slepikas@el.vgtu.lt*

Introduction

Although application areas of linear induction motors (LIM) and on it base designed linear electric drives expand [1-6], LIM and linear electric drives are not mass-produced, because every time LIM and linear electric drives need to be adjusted to specific control equipment to make linear electric drives more advanced then movement produced by rotary asynchronous motor and connecting links used to change rotary to linear motion. Therefore it is necessary to design new LIM and produce new linear electric drives for each application.

The force-speed characteristics of designed and produced new LIM and linear electric drives frequently do not fit the specification and they require some adjustment. The industry automatics uses small power LIM widely with linear force-speed characteristics.

There is evaluated [7] that this kind of motors has a current asymmetry with an influence of the end effect at low slip region it has different influence to force-speed characteristic. And it can be said that LIM force-speed characteristic crosses speed axis at synchronous speed point.

Force-speed characteristic of LIM is determined by two parameters: fixed synchronous speed and starting force. Therefore, correction or regulation of LIM (in cylindrical construction case – CLIM) starting force can be adjusted in the way its static and dynamic characteristics corresponds designed.

Adjustment of cylindrical construction linear induction motor (CLIM) starting force

Linear electric drives with CLIM (Fig. 1) work in short-time duty and power indexes (inductor current intensity, power and efficiency coefficient are secondary factors). Therefore, starting force of CLIM can be corrected with untraditional method – by creating phase asymmetry with CLIM connected in specific method.

Assuming short time duty mode of CLIM it's starting force can be varied in this way [8]: a) by changing polarity of one coil of CLIM phase winding; b) by changing polarity of two coils connected to different phase

windings; c) by changing polarity of all three marginal coils connected to different phase windings (to intercross the ends of these coils); d) to intercross ends of two coils in one phase and change polarity of one coil in the other two phases; to shorten marginal coil of one phase winding; f) to disconnect one coil from a phase winding.

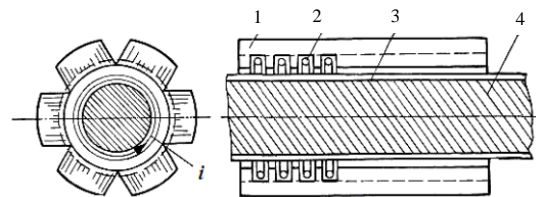

Fig. 1. Construction of CLIM: 1 – magnet of inductor; 2 – winding coil; 3 – LIM secondary element; 4 – core

Connection of coils by: a, b, c, d decrease starting force to: 0,841; 0,825; 0,81; 0,518, relative to starting force obtained with normal connection of coils. The connections of e, f increase starting force until relatively to 1,032 and 1,127.

The advantages of correction of CLIM starting force when the drive works in short-term mode (switch, breakers,) encourages analyzing other CLIM winding connection methods (Fig. 2).

From Fig. 3 we can observe that new CLIP (Fig. 2.) coil winding connection methods expands opportunities of earlier analyzed methods.

Adjustment and control of starting force of flat construction linear induction motors (LIM)

Starting force of flat construction LIM can be adjusted with shifting magnetically double sided LIM with respect to another LIM (Fig. 4).

For longitudinal shift (direction 6; Fig. 4 [9]) is also equivalent discrete control available, while upper inductor supply, who's phase sequence is *A B C*, and bottom inductor windings are connected to three phase voltage supply, who's phase sequence is *B C A* or *C A B* (Fig. 5).

Electrically and magnetically double sided LIM starting force can be controlled while switching windings

from parallel to serial or disconnecting one inductor winding [10].

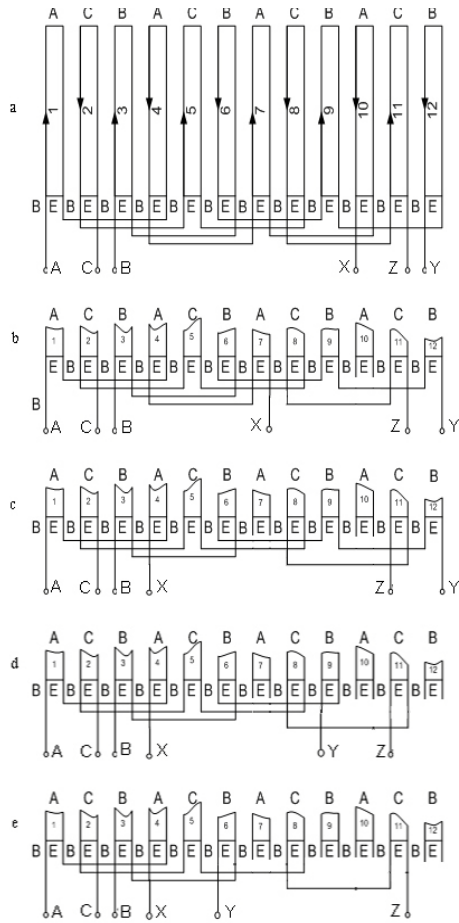

Fig. 2. Connection diagrams of CLIM coil windings

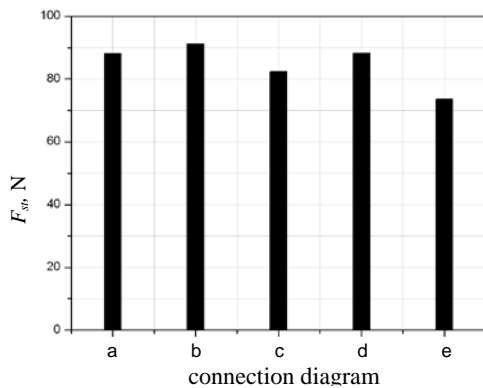

Fig. 3. Dependence of CLIM relative starting force to CLIM coil winding connection diagrams (Fig. 2)

It appear from the analysis of low power LIM [10], that after the disconnecting of one LIM winding when distance between LIM inductors (not magnetical interval) changes from 8 to 13 mm, LIM starting force decreases 2,066 times, it is around twice. This shows force created by

two inductors be multiplied by 2 calculated electrically one-sided or magnetically double-sided LIM starting forces that mean we can use superposition low. This allows us to calculate starting force of the LIM whose inductors are shifted longitudinally to each other by vectorically adding separate fluxes created by different inductors.

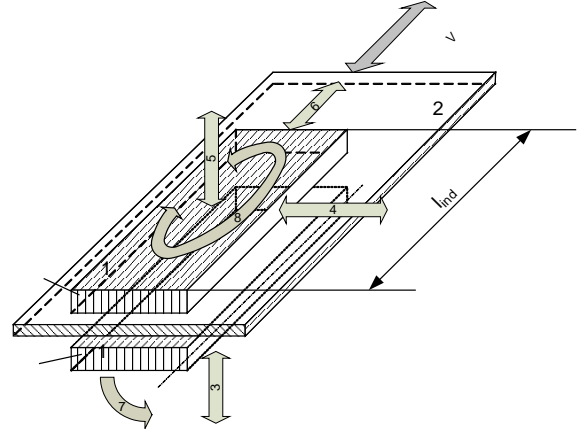

Fig. 4. Starting force control methods of flat construction LIM: 1 – LIM inductor; 2 – LIM secondary element; 3, 5 – control of starting force, while changing direction between inductors; 4 – control, while shifting inductor traverse direction; 6 – control, while shifting inductors longitudinally; 7 – control by tilting one inductor with respect to the other; 8 – control by turning one inductor with respect to other; v – direction of movement of LIM secondary element

Work [3] presents expressions for LIM inductor created force and magnetic flux in air-gap. After reconstruction dependence of LIM starting force and flux can be presented as:

$$F = \frac{m_1 a_1}{v_{1N}} \cdot \frac{\epsilon_{0N} \Phi^2 c_1^2 f_{1N}^2}{I + \epsilon_{0N}^2 (I - 2a_2 + a_1^2) \cdot X_{P1N}}, \quad (1)$$

where m_1 – number of LIM inductor phases; a_1 and a_2 – approximation coefficient; ϵ_{0N} – magnetic number of Reynolds of stopped LIM; Φ – sum of magnetic flux; c_1 – coefficient of LIM phase winding; f_{1N} – phase frequency of power supply; X_{P1N} – resistance of main inductance.

When magnetic flux is created by two inductors, flux Φ in (1) corresponds to resultant flux, it depends on inductor shift relative to each other or phase sequence (Fig. 5).

Fig. 6 shows fundamental evaluation of LIM resultant flux when inductors are shifted with respect to each other by third of pole step τ , corresponds to 180° .

Theoretical and experimental characteristics of LIM starting force dependence on inductor shift angle are presented in Fig. 7. From the curves we can see that calculation errors, increases LIM inductor supply voltage because inductor magnetic circuit is finite length (Fig. 5) and increased voltage strength's leakage flux.

Then resultant flux can be expressed by formula:

$$\Phi_\Sigma = 2\Phi_{1(2)} \cos \frac{\alpha}{2}, \quad (2)$$

where Φ_{Σ} – sum of magnetic flux; $\Phi_{1(2)}$ – fluxes of separate inductors; α – angle of inductors shifted with respect to each other.

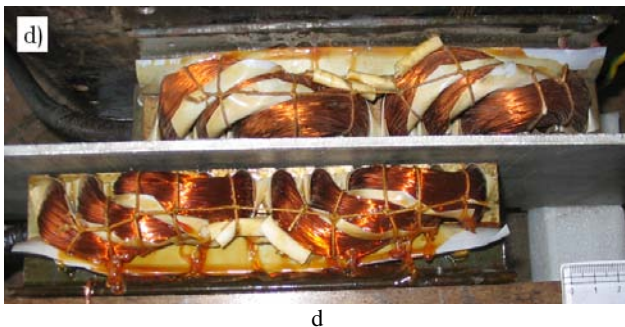
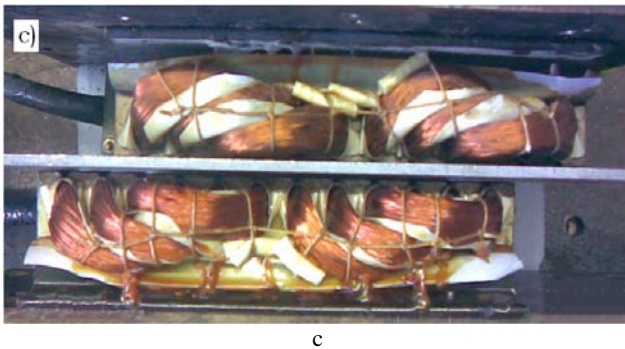
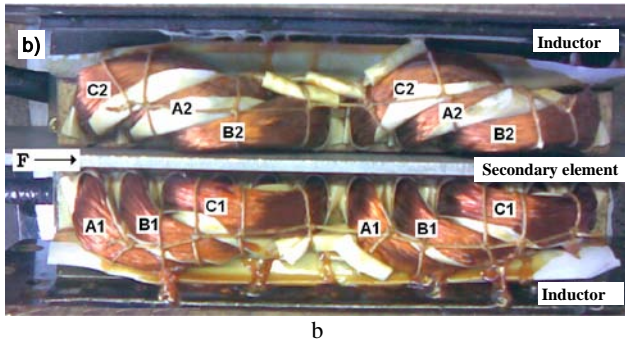
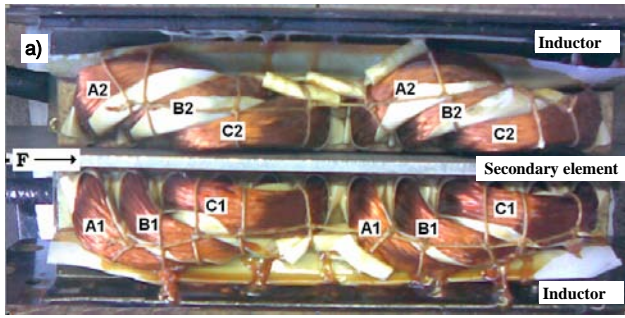

Fig. 5. Control of TAV starting force, while changing phase sequence (a, b) and shifting inductors with respect to each other (c, d)

Fig. 8 is experimental characteristics of starting force produced by LIM over the inductor shift, while one inductor supply voltage U_{AB}, U_{BC}, U_{CA} system, and phase sequence are changed: 1) U_{AB}, U_{BC}, U_{CA} ; 2) U_{BC}, U_{CA}, U_{AB} ; 3) U_{CA}, U_{AB}, U_{BC} .

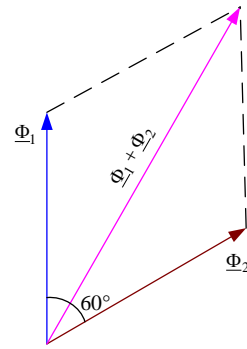

Fig. 6. Diagrams of LIM flux when LIM inductors are shifted over third of the pole step

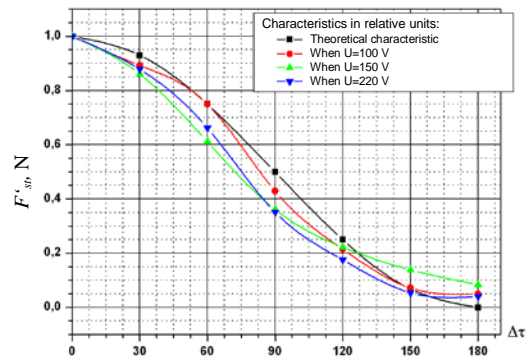

Fig. 7. Theoretical and experimental LIM starting force dependence on angle between shifted inductors

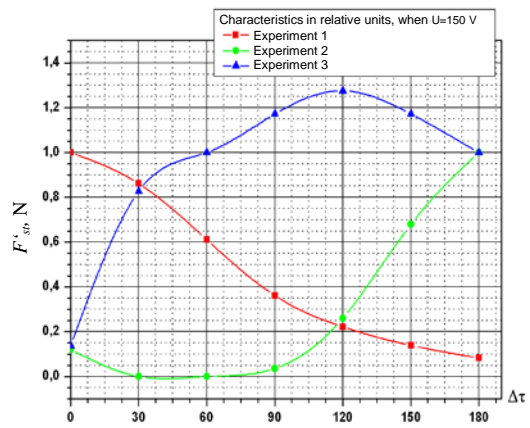

Fig. 8. Experimental characteristics of starting force produced by LIM over the inductor shift, while one inductor supply voltage U_{AB}, U_{BC}, U_{CA} system, and phase sequence are changed: 1) U_{AB}, U_{BC}, U_{CA} ; 2) U_{BC}, U_{CA}, U_{AB} ; 3) U_{CA}, U_{AB}, U_{BC} .

These characteristics show that there are big control opportunities of LIM starting force. For example, starting force of LIM can be controlled by discrete method by

switching LIM phase sequence. This control is convenient for load (goods) push from the carrier.

Conclusions

1. The construction of linear induction motor enables us to control starting force by methods, which cannot be used for rotary asynchronous motor torque control.

2. Theoretical characteristics of LIM starting force dependence on inductor shift over each other expresses real process with sufficient accuracy.

3. It is proposed new control method of LIM starting force, when position of inductors are defined in advance (for slow processes) or desired force – when switching one of the winding phase of LIM inductor (fast process).

References

1. Rinkevičienė R., Poška A., Smilgevičius A. Problems of Investigations and Development of Mechatronic Systems with Linear Induction Motors // Proceedings of the 11 International Conference EPE – PESC. Riga, Latvia. – 2004. – P. 3-296–3-300.
2. Budig P. K. The application of linear motors // Proceedings of the International Conference on Power Electronics and Motion Control. – 2000. – Vol.3. – P. 1336–1341.
3. Poška A. J. Specialiosios automatinės sistemos. Habilitacinis darbas. Technikos mokslai, elektronika ir elektrotechnika (7C). – Vilnius: Technika, 1995. – 204 p.
4. Savickienė Z., Poška A. J. Simplified Calculation of Linear Induction Electric Drives Characteristics // Electronics and Electrical Engineering. – Kaunas: Technologija, 2007. – No. 5(77). – P. 15–18.
5. Rinkevičienė R., Batkauskas V. Modeling and investigation of vector controlled induction drive // Electronics and Electrical Engineering. – Kaunas: Technologija, 2008. – No. 1 (81). – P. 53–56.
6. Smilgevičius A. Tiesiaeigių elektros variklių tyrimai Lietuvoje // Elektronika ir elektrotechnika. – Kaunas: Technologija, 2004. – Nr. 1(50). – P. 22–27.
7. Rinkevičienė R., LISAUSKAS S. Tiesiaeigių mechatroninių sistemų modeliai // Elektronika ir elektrotechnika. – Kaunas: Technologija, 2003. – Nr. 4 (46). – P. 69–73.
8. Poška A.; Rinkevičienė, R. Dynamics of electric drive of high voltage circuit-breaker for shunting phase fault // EMD'2003. Proceedings of the XIII International Conference on Electromagnetic Disturbances. ISBN 83-88229-46-X. Bialystok, Poland, 2004. – P. 155–158.
9. Радзявичюс Л. Ю. Линейный асинхронный двигатель с расслоенным вторичным элементом. Автореферат дис. канд. техн. наук. Харьковский ордена Ленина политехн. ин-т. им. В. И. Ленина. – Харьков, 1981. – 20 с.
10. Savickienė Z., Poška A. J. Sklendžių tiesiaeigės elektros pavaros // Elektrotechnika. 20(29). Mokslo darbai. – Kaunas: Technologija, 1996. – P. 141–146.

Received 2009 10 21

A. J. Poška, Z. Savickienė, A. Šlepikas. Control and Adjustment of Linear Induction Motor Starting Force // Electronics and Electrical Engineering. – Kaunas: Technologija, 2010. – No. 2(98). – P. 21–24.

Methods of adjustment and control of small power tubular and flat construction linear induction motors starting force are considered. Experimental results of starting force adjustment of short time duty cylindrical linear induction motor by disconnecting its separate coils and combination of them are analysed. The theoretical and experimental results of electrically and magnetically double sided flat linear induction motor starting force adjustment and control by shifting one inductor with respect other in the secondary element movement direction and changing inductors supply voltage phase combinations. III. 8, bibl. 10 (in English; summaries in English, Russian and Lithuanian).

A. Ю. Пошка З. Савицкене, А. Шляпикас. Управление и настройка пусковой силы линейных асинхронных двигателей // Электроника и электротехника. – Каunas: Технология, 2010. – № 2(98). – P. 21–24.

Анализируются способы управления и настройка пусковой силой низкоскоростных маломощных линейных асинхронных двигателей (ЛЯД) цилиндрической и плоской конструкции (ЦЛЯД и ПЛЯД). Приведены результаты экспериментального исследования возможности изменения пусковой силы ЦЛЯД, предназначенных для кратковременного режима работы, путем выключения отдельных катушек трехфазной обмотки индуктора ЦЛЯД. Анализируются результаты экспериментального и теоретического исследования способов коррекции и управления пусковой силой электрически и магнитно - двухстороннего ПЛЯД путем смещения одного индуктора относительно другого в направлении движения вторичного элемента ПЛЯД и путем изменения чередования фаз питающего напряжения ПЛЯД. Ил. 8, библи. 10 (на английском языке: рефераты на английском, русском и литовском яз.).

A. J. Poška, Z. Savickienė, A. Šlepikas. Tiesiaeigių asinchroninių variklių paleidimo jėgos valdymas ir reguliavimas // Elektronika ir elektrotechnika. – Kaunas: Technologija, 2010. – Nr. 2(98). – P. 21–24.

Nagrinėjami cilindrinės ir plokščios konstrukcijos mažos galios ir greičių tiesiaeigių asinchroninių elektros variklių (TAV: CTAV ir PTAV) paleidimo jėgos valdymo ir korekcijos būdai. Pateikiami trumpalaikiam darbo režimui skirtų CTAV paleidimo jėgos koregavimo, išjungiant trifazio CTAV atskiras rites ar jų derinius (kombinacijas), eksperimentinio tyrimo rezultatai. Analizuojami elektriškai ir magnetiškai dvipusio PTAV paleidimo jėgos korekcijos ir valdymo, perstumiant PTAV vieną induktorių kito atžvilgiu antrinio elemento judėjimo kryptimi ir keičiant induktoriaus maitinimo įtampų fazių kombinacijas teorinio ir eksperimentinio tyrimo rezultatai. II. 8, bibl. 10 (anglų kalba; santraukos anglų, rusų ir lietuvių k.).