

Control Design and Simulation of Unified Power Flow Controller

K.R. Padiyar, Senior Member
Department of Electrical Engineering
Indian Institute of Science
Bangalore, India 560012

A.M.Kulkarni

Abstract—The UPFC is a solid state controller which can be used to control active and reactive power flows in a transmission line. In this paper we propose a control strategy for UPFC in which we control real power flow through the line, while regulating magnitudes of the voltages at its two ports. We design a controller for this purpose which uses only local measurements. The control strategy is evaluated using digital simulation for a case study.

1 Introduction

The Unified Power Flow Controller (UPFC) [1,2] is the most versatile of the FACTS controllers envisaged so far. It can not only perform the functions of the STATCON, TCSC, and the phase angle regulator but also provides additional flexibility by combining some of the functions of the above controllers. The main function of the UPFC is to control the flow of real and reactive power by injection of a voltage in series with the transmission line. Both the magnitude and the phase angle of the voltage can be varied independently. Real and reactive power flow control can allow for power flow in prescribed routes, loading of transmission lines closer to their thermal limits and can be utilized for improving transient and small signal stability of the power system. The schematic of the UPFC is shown in Fig.1. The UPFC consists of 2 branches. The series branch consists of a voltage source converter which injects a voltage in series through a transformer. Since the series branch of the UPFC can inject a voltage with variable magnitude and phase angle it can exchange real

power with the transmission line. However the UPFC as a whole cannot supply or absorb real power in steady state (except for the power drawn to compensate for the losses) unless it has a power source at its DC terminals. Thus the shunt branch is required to compensate (from the system)

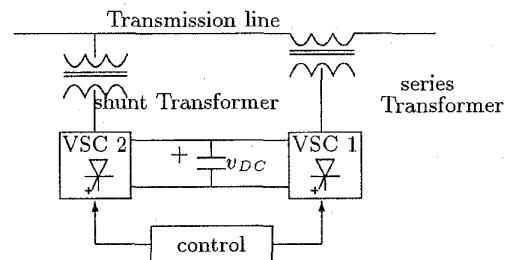

Figure 1: UPFC

for any real power drawn/ supplied by the series branch and the losses. If the power balance is not maintained, the capacitor cannot remain at a constant voltage. The relationship can be expressed mathematically as (see Fig. 2):

$$\Re(\sqrt{V_{u1}} \bar{I}_1^* + \sqrt{V_{u2}} \bar{I}_2^*) - P_{loss} = 0 \quad (1)$$

In addition to maintaining the real power balance, the

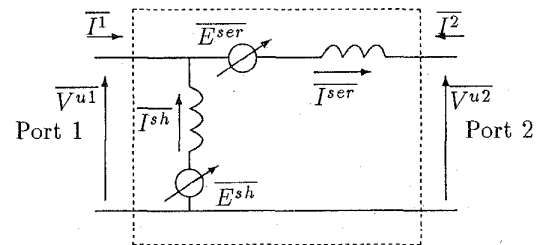

Figure 2: UPFC as a two port device

shunt branch can *independently* exchange reactive power with the system.

The main advantage of the power electronics based FACTS controllers over mechanical controllers is their speed. Therefore the capabilities of the UPFC need to

PE-172-PWRD-0-12-1997 A paper recommended and approved by the IEEE Transmission and Distribution Committee of the IEEE Power Engineering Society for publication in the IEEE Transactions on Power Delivery. Manuscript submitted June 5, 1997; made available for printing December 12, 1997.

be exploited not only for steady state load flow control but also to improve stability. However it is not obvious as to how to use the series voltage and shunt current (subject to the power balance constraint) for UPFC control. It is in this context that suitable control strategies and controller design to achieve the same is of importance.

A control strategy, in general, should preferably have the following attributes :

1. Steady state objectives (ie. real and reactive power flows) should be readily achievable by setting the references of the controllers.

2. Dynamic and transient stability improvement by appropriate modulation of the controller references.

While the application of UPFC for load flow control and in stability improvement has been discussed in [3,4], a detailed discussion on control strategies backed by performance evaluation is not yet reported in literature. In this paper we propose a control strategy for UPFC in which we control real power flow through the line, while regulating magnitudes of the voltages at its two ports. We design a controller for this purpose which uses only *local* measurements. The control strategy is evaluated using transient digital simulation for a case study.

2 Control Strategy

The UPFC allows us three “degrees of freedom”

1. Magnitude and angle of series voltage
2. Shunt reactive current.

The real and reactive power flow in the line can be controlled independently using the series injected voltage (see [1] for an elaborate exposition).

It should be noted that the UPFC uses Voltage Source Converters (VSCs) for series voltage injection as well as shunt current control. The injection of series voltage can respond almost instantaneously to an order. The shunt current, however, is controlled indirectly by varying the shunt converter voltage (closed loop control of shunt current is required).

2.1 Series injected voltage control

To achieve real and reactive power flow control we need to inject series voltage of the appropriate magnitude and angle. The injected voltage can be split into two components which are in phase (“real voltage”) and in quadrature (“reactive voltage”) with the line current. It is to be noted that the line current measurement is *locally available*. The real power can be effectively controlled by varying the series reactance of the line. Reactive voltage injection is like series insertion of reactance except that the injected voltage can be independent of the transmission line current. Thus we control active power flow using the reactive voltage. It should be kept in mind that real and reactive power references are obtained from (steady state) power flow requirements. The real power reference can also be modulated to improve damping and transient sta-

bility. In addition, reactive power can be controlled to prevent dynamic over/undervoltages. In fact, instead of having closed loop control of reactive power using the real voltage, the voltage at port 2 (see Fig. 2) of the UPFC can be controlled readily by *calculating* the required real voltage to be injected. We can control reactive power indirectly by changing the voltage reference for port 2.

2.2 Shunt Current Control

It is well known that shunt reactive power injection can be used to control bus voltage. Thus the shunt current is split into real (in phase with bus voltage) and reactive current components. The reference value for the real current is set so that the capacitor voltage is regulated (which implies power balance). The reactive current reference is set by a bus voltage magnitude regulator (for port 1 of the UPFC). The voltage reference of the voltage regulator itself can be varied (slowly) so as to meet steady state reactive power requirements.

3 Controller Design

To simplify the design procedure we carry out the design for the series and shunt branches separately. In each case, the external system is represented by a simple equivalent. The design has to be validated when the various subsystems are integrated.

The design tasks are listed below:

1. Series injected voltage control
 - a. Power Flow control using reactive voltage.
 - b. UPFC port 2 voltage control using real voltage.
2. Shunt converter voltage control
 - a. Closed loop current (real and reactive) control.
 - b. UPFC port 1 voltage control using reactive current.
 - c. Capacitor voltage regulation using real current.

The basic design considerations are illustrated using simplified system models. The performance of all the controllers is subsequently evaluated using detailed simulations for a case study.

4 Series injected voltage controller

4.1 Power flow control

In this section we consider the control of real power using reactive voltage (real voltage injection is assumed to be zero). We carry out the analysis on the simplified system shown below in Fig. 3. The differential equations for the current at port 2 in the D-Q (synchronously rotating at system frequency ω_s) frame of reference [5] are given by:

$$\frac{di_D^{ser}}{dt} = -\frac{r_{ser}\omega_b}{x_{ser}}i_D^{ser} - \omega_o i_Q^{ser} + \frac{\omega_o}{x_{ser}}(v_D^{u2} - v_D^R) \quad (2)$$

$$\frac{di_Q^{ser}}{dt} = -\frac{r_{ser}\omega_b}{x_{ser}}i_Q^{ser} + \omega_o i_D^{ser} + \frac{\omega_o}{x_{ser}}(v_Q^{u2} - v_Q^R) \quad (3)$$

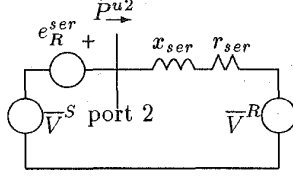

Figure 3: Simplified system

where,

$$v_D^{u2} = v_D^{u1} + e_D^{ser} \quad (4)$$

$$v_Q^{u2} = v_Q^{u1} + e_Q^{ser} \quad (5)$$

and, ω_b is the base frequency. The subscripts 'D' and 'Q' denote the variables in the D-Q frame. (v_D^R, v_Q^R) , (v_D^{u1}, v_Q^{u1}) and (v_D^{u2}, v_Q^{u2}) are the components of the voltages at the receiving end bus, UPFC port 1 and port 2 respectively. We assume in this section that $\overline{V^s} = \overline{V^{u1}} = \text{constant}$. Power at receiving bus P^R is approximately equal to that at port 2 (P^{u2}) of the UPFC in the steady state; therefore we control the power at port 2 since the feedback signal is readily available.

$$P^{u2} = v_D^{u2} i_D^{ser} + v_Q^{u2} i_Q^{ser} \quad (6)$$

Injected reactive and real voltages are written in terms of injected voltages in the D-Q frame (e_D^{ser}, e_Q^{ser}) as,

$$e_R^{ser} = e_D^{ser} \cos(\phi^i) - e_Q^{ser} \sin(\phi^i) \quad (7)$$

$$e_P^{ser} = e_D^{ser} \sin(\phi^i) + e_Q^{ser} \cos(\phi^i) \quad (8)$$

where $\phi^i = \tan^{-1} \frac{i_D^{ser}}{i_Q^{ser}}$

For the design of the control of power flow by reactive voltage using output feedback, we examine the transfer function $(\frac{\Delta P^{u2}(s)}{\Delta u(s)})$ of the linearized system at various operating points. $u(s)$ is the reactive voltage order obtained from the output feedback controller. Since the injection of voltage can respond almost instantaneously to an order, we can assume $e_{Rord}^{ser} = e_R^{ser}$.

In Fig. 4, we show the Bode plot of the transfer function for quiescent voltage injection = 0. The main concern in the design of an output feedback controller is the stability of the oscillatory mode (in the D-Q frame of reference: nearabout ω_o rads/s) associated with the series inductance.

To make the system more amenable to feedback control we use an auxiliary feedback using the signal,

$$-k\phi^i(s) \frac{sT_w}{1+sT_w}$$

as shown in Fig. 5. Note that the contribution of this auxiliary feedback is zero in steady state. An advantage of using the auxiliary feedback instead of conventional cascade compensators is that even if the output feedback control of active power is not used, the auxiliary signal can still be used to improve stability of network mode.

From the Bode plot it is seen that the transfer function

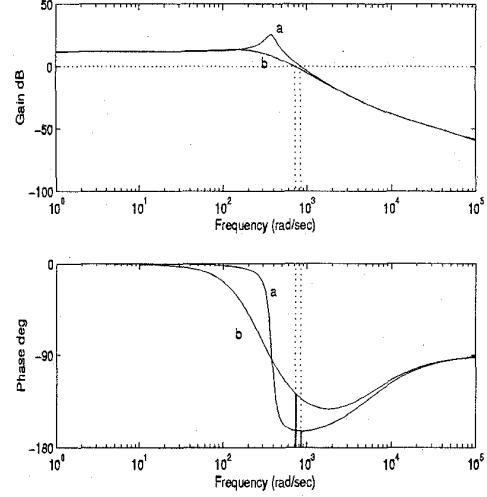

Figure 4: Bode Plots of $\frac{\Delta P^{u2}(s)}{\Delta u(s)}$ (a) without auxiliary feedback (b) with auxiliary feedback

$(\frac{\Delta P^{u2}(s)}{\Delta u(s)})$ with the auxiliary feedback has a vastly improved phase margin. This allows larger gains to be used in the output feedback controller with a consequent speeding up of the response.

While the plots are shown for one operating point: $e_{R0}^{ser} = 0$, the improvement is there for positive and negative e_{R0}^{ser} also.

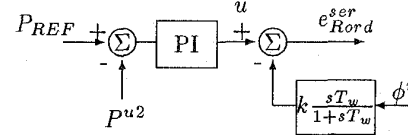

Figure 5: Real Power Controller

4.2 Port 2 voltage control

The voltage at port 2 of the UPFC is algebraically related to that at port 1 and the reactive voltage injected (e_R^{ser}) for power flow control. (For simplicity the series transformer reactance is clubbed with the line impedance). The voltage relation is given by:

$$\begin{aligned} V^{u2} &= \sqrt{(v_D^{u2})^2 + (v_Q^{u2})^2} \\ &= \sqrt{(v_D^{u1} + e_D^{ser})^2 + (v_Q^{u1} + e_Q^{ser})^2} \\ &= \sqrt{(v_R^{u1} + e_R^{ser})^2 + (v_P^{u1} + e_P^{ser})^2} \end{aligned} \quad (9)$$

$$v_R^{u1} = v_D^{u1} \cos(\phi^i) - v_Q^{u1} \sin(\phi^i) \quad (10)$$

$$v_P^{u1} = v_D^{u1} \sin(\phi^i) + v_Q^{u1} \cos(\phi^i) \quad (11)$$

Since all quantities are locally available, we can easily calculate real voltage e_P^{ser} to be injected to obtain desired

magnitude of V^{u2} (see Fig. 6). Note that there are two solutions of e_P^{ser} ; the solution which has a lower magnitude is chosen.

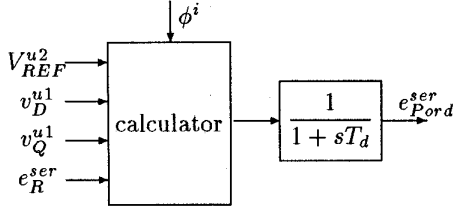

Figure 6: Port 2 Voltage Controller

5 Shunt Current Control

The shunt current is controlled by varying the magnitude and angle of the shunt converter voltage (see Fig. 2). The dynamical equations in the D-Q frame are given by,

$$\frac{di_D^{sh}}{dt} = -\frac{r_{sh}\omega_b}{x_{sh}}i_D^{sh} - \omega_o i_Q^{sh} + \frac{\omega_b}{x_{sh}}(e_D^{sh} - v_D^{u1}) \quad (12)$$

$$\frac{di_Q^{sh}}{dt} = -\frac{r_{sh}\omega_b}{x_{sh}}i_Q^{sh} + \omega_o i_D^{sh} + \frac{\omega_b}{x_{sh}}(e_Q^{sh} - v_Q^{u1}) \quad (13)$$

where,

r_{sh}, x_{sh} =shunt transformer resistance and leakage reactance respectively

e_D^{sh}, e_Q^{sh} =converter output voltage components

v_D^{u1}, v_Q^{u1} =voltage components at the bus into which current is injected (port 1 of the UPFC)

Reactive and Real current are defined as

$$i_R^{sh} = i_D^{sh} \cos(\theta^{u1}) - i_Q^{sh} \sin(\theta^{u1}) \quad (14)$$

$$i_P^{sh} = i_D^{sh} \sin(\theta^{u1}) + i_Q^{sh} \cos(\theta^{u1}) \quad (15)$$

where,

$$\theta^{u1} = \tan^{-1} \frac{v_D^{u1}}{v_Q^{u1}}$$

$$V^{u1} = \sqrt{(v_D^{u1})^2 + (v_Q^{u1})^2}$$

For control of shunt current we proceed in a way similar to the one outlined by Schauder and Mehta[6]. We can rewrite the differential equations as

$$\frac{di_R^{sh}}{dt} = -\frac{r_{sh}\omega_b}{x_{sh}}i_R^{sh} - \omega i_P^{sh} + \frac{\omega_b}{x_{sh}}e_R^{sh} \quad (16)$$

$$\frac{di_P^{sh}}{dt} = -\frac{r_{sh}\omega_b}{x_{sh}}i_P^{sh} + \omega i_R^{sh} + \frac{\omega_b}{x_{sh}}(e_P^{sh} - V^{u1}) \quad (17)$$

Note that,

$$e_R^{sh} = e_D^{sh} \cos(\theta^{u1}) - e_Q^{sh} \sin(\theta^{u1}) \quad (18)$$

$$e_P^{sh} = e_D^{sh} \sin(\theta^{u1}) + e_Q^{sh} \cos(\theta^{u1}) \quad (19)$$

$$\omega = \omega_o + \frac{d\theta^{u1}}{dt} \quad (20)$$

If we vary the inverter output voltages as follows,

$$e_R^{sh} = e_{Rord}^{sh} = \frac{\omega}{\omega_b} x_{sh} i_P^{sh} + \frac{x_{sh}}{\omega_b} u_R \quad (21)$$

$$e_P^{sh} = e_{Pord}^{sh} = -\frac{\omega}{\omega_b} x_{sh} i_R^{sh} + V^{u1} + \frac{x_{sh}}{\omega_b} u_P \quad (22)$$

the differential equations (16) and (17) get decoupled as follows,

$$\frac{di_R^{sh}}{dt} = -\frac{r_{sh}\omega_b}{x_{sh}}i_R^{sh} + u_R \quad (23)$$

$$\frac{di_P^{sh}}{dt} = -\frac{r_{sh}\omega_b}{x_{sh}}i_P^{sh} + u_P \quad (24)$$

Independent output feedback control of the currents is achieved by varying u_R, u_P as,

$$u_R(s) = G_{sh}(s)(i_{RREF}^{sh}(s) - i_R^{sh}(s)) \quad (25)$$

$$u_P(s) = G_{sh}(s)(i_{PREF}^{sh}(s) - i_P^{sh}(s)) \quad (26)$$

$G_{sh}(s)$ is the transfer function of the controller (we have used a PI controller).

The reactive current reference is set by a voltage regulator (PI type) for the UPFC bus (port 1).

The dynamical equation for the capacitor voltage is given by

$$\frac{dv_{DC}}{dt} = -\frac{g_{cap}\omega_b}{b_{cap}}v_{DC} - i_{DC}^{sh} - i_{DC}^{ser} \quad (27)$$

g_{cap}, b_{cap} are the conductance and susceptance of the capacitor respectively.

Any real power drawn/supplied by the series branch (due to e_P^{ser}) or by the shunt branch (due to real current injection i_P^{sh}) manifests as DC side currents i_{DC}^{ser} and i_{DC}^{sh} respectively. Since we allow variable real series voltage injection, and due to the losses, the capacitor voltage tends to change. To compensate this by i_{DC}^{sh} , we set the real current reference (i_{PREF}^{sh}) as the output of a PI type capacitor voltage regulator.

The controller block diagram is shown in Fig. 7.

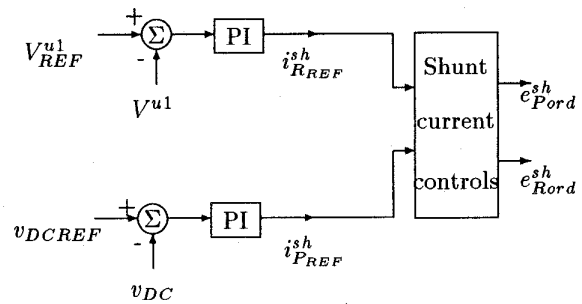

Figure 7: Shunt current controller

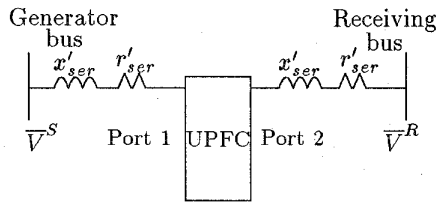

Figure 8: System under study

6 Case Study

We consider the system shown in Fig. 8 .

Nominal System Data:

$$r'_{ser} = 0.0075, x'_{ser} = 0.075, x_{sh} = 0.15, r_{sh} = 0.01.$$

$$b_{cap} = 2.0, g_{cap} = 0.02, \bar{V}^S = 1.0\angle 30, \bar{V}^R = 1.0\angle 0$$

All quantities are on the UPFC MVA base which is assumed to be $(\frac{1}{3})^{rd}$ of the transmission line MVA base.

Both the shunt and series branches of the UPFC consist of two 12- pulse converters each. Magnitude control is achieved by *vector addition* of the output of the 2 twelve pulse converters [7]. The magnitude (E) is varied by displacing the output of one 12 pulse converter with respect to the other while maintaining the required phase (ϕ) of the resultant voltage. This is done as shown in Fig. 9. The resultant voltage is given by,

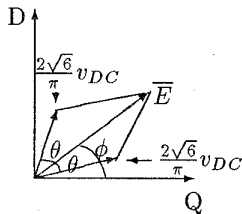

Figure 9: Magnitude control

$$\begin{aligned} \bar{E} &= \frac{2\sqrt{6}}{\pi} v_{DC} \angle(\phi + \theta) + \frac{2\sqrt{6}}{\pi} v_{DC} \angle(\phi - \theta) \\ &= \frac{4\sqrt{6}}{\pi} v_{DC} \cos(\theta) \angle\phi \end{aligned} \quad (28)$$

Note that the factor $\frac{2\sqrt{6}}{\pi}$ relates the capacitor voltage (v_{DC}) to the line to line rms inverter output voltage for a 12 pulse converter. With the knowledge of the capacitor voltage and the inverter voltage order, θ can be calculated. While this scheme of magnitude control may not be optimal from the point of view of equipment utilization and harmonics, we use it to here only to validate the control strategy.

6.1 Simulation Results

Digital simulation has been carried out using SIMULINK [8] dynamic system simulation software. The switchings of the converters are modelled as switching functions (the switches are assumed to be ideal) in the differential equations. The simulation method used is Runge-Kutta 4th order method (this is an *explicit* integration method and is recommended for systems with discontinuities) with variable time step feature.

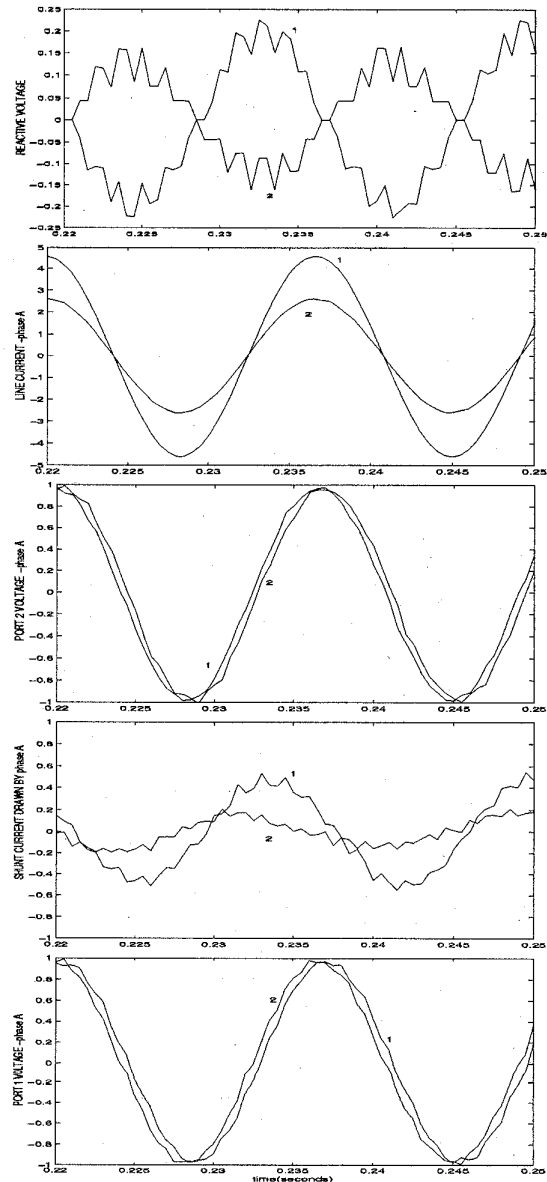

Figure 10: Steady state Waveforms

(a) STEADY STATE WAVEFORMS

In Fig.10 we show the steady state waveforms for 2 cases:

$$1. V^S = 0.975, P_{REF} = 4.5, V_{REF}^{u1} = V_{REF}^2 = 0.975$$

To allow for a power flow of 4.5 pu the UPFC injects a

“capacitive” voltage in series with the line. Also, to maintain the voltage at port1 the shunt branch injects reactive power in addition to drawing real current to maintain power balance.

2. $V^S = 1.0$, $P_{REF} = 2.5$, $V_{REF}^{u1} = V_{REF}^{u2} = 0.975$
Here the UPFC injects an “inductive” voltage in order to maintain a power flow of 2.5 pu.

(b) RESPONSE FOR A PULSE DISTURBANCE IN POWER REFERENCE

The UPFC can respond rapidly (order of one cycle) to a pulse change in power reference (4.5 to 2.5 to 4.5 pu) (Fig. 11). At the same time it maintains its port voltages constant. While reactive voltage is changed in order to change the power flow, the real voltage injection and the shunt reactive current maintain the port voltage magnitudes constant.

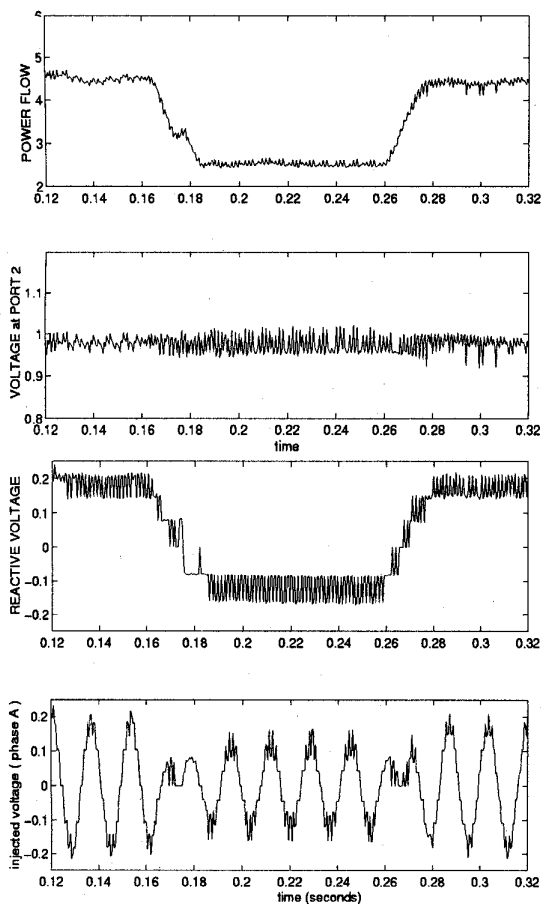

Figure 11: Response to pulse change in P_{REF}

(c) RESPONSE FOR A PULSE DISTURBANCE IN SENDING END VOLTAGE

The capability of the UPFC to regulate both the power and voltages at both ports is clearly seen for a pulse disturbance in sending end voltage magnitude (1.05 to 0.975 to 1.05 pu) (see Fig. 12). The response time is of the order of a cycle.

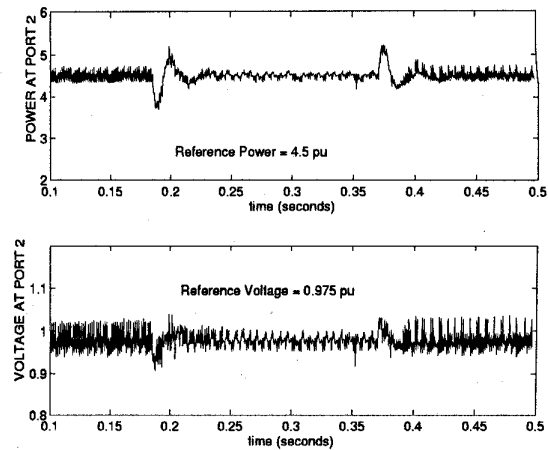

Figure 12: Response to pulse change in sending end voltage

The high frequency oscillations observed in steady state in Figs. 11 and 12 are due to the presence of voltage harmonics introduced by the converters.

7 Modulation Controller [9]

The fast response time of the UPFC can be utilised to improve damping and transient stability of the power system. If we consider the case of a SMIB system where the generator rotor is oscillating sinusoidally, restoring torques are set up which oppose the motion. The component of the torque in phase with the rotor angle is called the synchronising torque and the component in phase with the rotor velocity is called the damping torque. Assuming the small signal rotor oscillations are governed by an approximate second order equation

$$Mp^2\Delta\delta + \frac{T_D}{\omega_B}p\Delta\delta + T_S\Delta\delta = 0 \quad (29)$$

where M is the inertia constant, p is the differential operator d/dt and ω_B is the base speed, T_S and T_D are the synchronising and damping torque coefficients, it is essential for the system to be stable that both T_S and T_D be positive. Trying to maintain a constant power in the line during contingencies prevents the flow of synchronising and damping torques. To damp power oscillations it is necessary to enhance damping torque and to improve transient stability it is necessary to enhance the synchronising torque. Hence, during a contingency the real power demand is changed to enhance both the damping and synchronising torques.

We consider the system of Fig. 8, where one of the voltage sources (V^S) is replaced by a generator (1.1 model; stator transients included). The generator rating is compatible with the transmission line rating.

The modulation controller structure is shown in Fig. 13 which supplements the controller shown in Fig. 5.

Since we consider a single radial line exporting power from

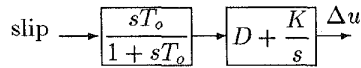

Figure 13: Modulation controller

the generator, power flow control is not meaningful; hence reactive voltage is modulated directly. The auxiliary control to damp network mode in the power flow controller is retained. D and K are constants to provide damping and synchronising powers in the line. A washout circuit is provided to eliminate any steady state bias in the controller.

The transient simulation results for a pulse in the input mechanical torque is shown in Fig. 14. While this disturbance is not realistic, the improvement brought in the system response is clearly seen both in maximum generator angle deviation as well as damping.

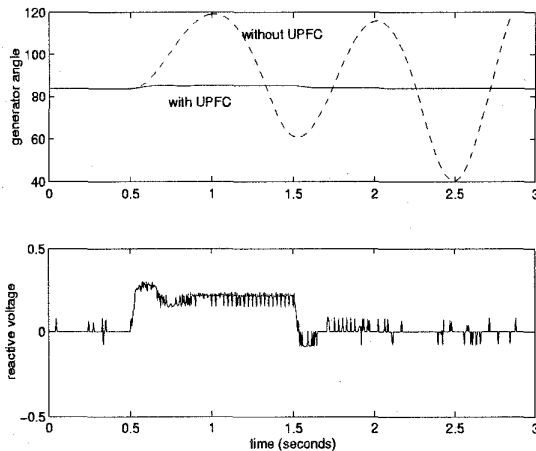

Figure 14: Response for pulse disturbance in input torque

8 Conclusions

In this paper we have proposed a control strategy for the UPFC. The salient features are:

1. Real power flow control by reactive voltage injection.
2. Indirect reactive power flow control by control of voltage at the two ports of the UPFC.

The controllers are designed independently and use locally available measurements. The simulation results for a case study indicate that this is a viable control scheme. By modulating the active power it is possible to bring a vast improvement in transient stability and damping.

While this paper gives the basic strategy and design considerations, further refinement is possible in the context of the recent advances in control theory. Also, performance evaluation considering effect of torsional dynamics of the generator is another aspect to be studied.

9 Acknowledgement

The financial support received from the Dept. of Science and Technology, Govt. of India under the project titled "Flexible AC Transmission Systems (FACTS) controllers" is gratefully acknowledged.

10 References

1. L.Gyugyi, C.D.Schauder, S.L.Williams, T.R.Rietman, D.R.Torgerson, A.Edris, "The Unified Power Flow Controller: A new Approach to Power Transmission Control", *IEEE Trans. on Power Delivery*, Vol. 10, No.2 April 1995, pp. 1085-1097.
2. L. Gyugyi, "Unified power flow concept for flexible AC transmission systems", *IEE Proc-C*, Vol.139, No.4, July 1992, pp.323-332.
3. D. Povh, R.Mihalic, I.Papic, "FACTS equipment for Load Flow Control in High Voltage Systems", *Cigre Symposium, Power Electronics in Power Systems*, Tokyo, May 1995.
4. R.Mihalic, P.Zunko, D.Povh, "Modelling of Unified Power Flow Controller and its impact on power oscillation damping", *Cigre Symposium, Power Electronics in Power Systems*, Tokyo, May 1995.
5. K.R.Padiyar, *Power System Dynamics - Stability and Control*, John Wiley and Sons (SEA) Pte Ltd, Singapore, 1996.
6. C.Schauder and H.Mehta, "Vector Analysis and Control of Advanced Static Var Compensator", *IEE Proc.-C*, Vol. 140, No.4, July 1993., pp.299-306.
7. Loren H. Walker, "10-MW GTO Converter for Battery Peaking Service", *IEEE Trans. on Industry Applications*, Vol. 26, No. 1, Jan/Feb 1990, pp. 63-72.
8. SIMULINK Users Guide, The Math Works Inc., Natick, Mass., 1993.
9. K.R.Padiyar and K. Uma Rao, "A Control Scheme for Unified Power Flow Controller to improve Stability of Power Systems", paper presented at the *Ninth National Power Systems Conference*, Kanpur, India, Dec. 1996.

Biographies

K.R.Padiyar: is Professor of Electrical Engineering at Indian Institute of Science, Bangalore, India. He obtained his BE degree in Electrical Engineering from Poona University in 1962, ME degree from I.I.Sc. in 1964, and PhD degree from University of Waterloo, Canada in 1972. He was with I.I.T, Kanpur from 1976-1987 prior to joining I.I.Sc..

His research interests are in the area of HVDC and FACTS, System Dynamics and Control. He has authored two books and over 150 papers. He is a Fellow of National Academy of Engineering (India).

A.M.Kulkarni: received his B.E. degree from the University of Roorkee and M.E. degree from Indian Institute of Science in Electrical Engineering in 1992 and 1994 respectively. He is currently working towards a PhD degree at the Indian Institute of Science. His research interests are in the area of FACTS and power system dynamics.