

Controlling Home Appliances Remotely Through Voice Command

Marriam Butt ^{#1}, Mamoona Khanam ^{#2}, Aihab Khan ^{#3}, Malik Sikandar Hayat Khiyal ^{#4}

[#]Department of software engineering Fatima Jinnah women university, FJWU, Rawalpindi, Pakistan

¹marriambuttfjwu@gmail.com, ³aihabkhan@yahoo.com, ⁴m.sikandarhayat@yahoo.com,

Abstract— the main concern in systems development is the integration of technologies to increase customer satisfaction. Research presented in this paper focuses mainly in three things first to understand the speech or voice of user second is to control the home appliances through voice call and third is to find intrusion in the house. The user can make a voice call in order to perform certain actions such as switching lights on/off, getting the status of any appliance etc. And when system finds intrusion it sends an alert voice message to preconfigured cell when the user is away from the place. The proposed system is implemented using voice Global System for Mobile Communications (GSM) and wireless technology based on .NET framework and Attention (AT) commands. Microsoft speech reorganization engine, speech SDK 5.1 is used to understand the voice command of user. As it is wireless so more cost effective and easy to use. The GSM technology used in system provide the everywhere access of the system for security. Experimental results show that the system is more secure and cost effective as compared to existing systems. We conclude that this system provides solution for the problems faced by home owner in daily life and make their life easy and comfortable by proposing cost effective and reliable solution.

Keywords-component; Voice GSM; Voice message; radio frequency (RF); AT commands.

I. INTRODUCTION

Home automation control system (HACS) is not a new concept a lot of work has done in this field and many solutions has proposed. Some of them have used internet and wireless technology to communicate and control the appliances [1, 2]. Others have used the Bluetooth or GSM technology to send the command for controlling the home appliances [3, 4].

Problem domain related to proposed technique is telecommunication remote automation of home appliances thorough telecom technology. The proposed research provides the cost effective system that helps to satisfy their security concerns of home related to daily life such as controlling the home appliances and intrusion detection through voice message. This system can be used in any environment. It is free from the geographical limitations and can be used every where being the GSM network available.

It is affordable to everyone as no expansive hardware is used in it. Cell phones are very common these days and almost everyone can make a call very easily. That's why cell phone is used in this system that makes it real world application. It is free from the geographical boundaries and can be used from anywhere where GSM is available. The proposed solution is to implement the HACS through voice command that controls

the home appliances by making a call from the preconfigured number to system and receive the voice message from the system to preconfigured number about the status of appliances over the GSM network.

AT commands are used to automatically receive the call on system from the preconfigured number and system also sends the voice message to preconfigured number about the status of appliances and intrusion through AT commands. Microsoft speech SDK 5.1 is used to reorganization of speech. Hence it is a research based real world project and is useful for working people and for those who live alone or stay out of their homes most of the time.

The system is implemented using .NET framework. AT commands set supporting voice as:

AT+FCLASS=8	for Voice Mode
ATD03004108768;	for making a call
ATA	for receiving a call
AT+VSM=128,8000	for Compression Mode
AT+ VTX	for Voice Transmition

The paper is organized in such a way that: section 2 discusses related work to proposed schemes, section 3 committed to proposed framework, section 4 discuss proposed technique along with algorithm ,section 5 discuss results and finally concluding remarks are given in section 6.

II. RELATED WORK

Nguyen et al. [1] proposed a Home appliance control system. Infrared ray and power line communication are used to control the home appliances system. This system helps user to checks the status of appliances and controls them remotely from everywhere. And this is done through their cellular phone or Internet. The simple approach to control the home appliances is given in this paper.

Haque et al. [2] proposed a system that controls the home appliances using the personal computer. This system is developed by using the Visual Basic 6.0 as programming language and Microsoft voice engine tools for speech recognition purpose. Appliances can be either controlled by timer or by voice command.

Khiyal et al. [3] proposed a system for controlling home appliances remotely that is useful for the people who are not at home mostly. The main objective of the system is to provide

security and control the home appliances such as AC, lights and alarms. The system is implemented by SMS technology that is used to transfer data from sender to receiver over GSM network. One or more computers can be used to control the home appliances. System send an alert SMS to authorized user when any intrusion is detected and user can in turn respond in order to overcome the situation. Moreover user can send SMS to system to get the status of home appliances and controlling them.

Jawarkar et al. [5] proposed the software system for communication between mobile and computer. UART 16550A chip is programmed using appropriate control format to support AT command. The mobile in this system is used for receiving and executing commands from preconfigured users and informing status about change in input to the user through SMS. The system can also send SMS to specified mobile user if there is a change in the status of the input ports. This system is not for time critical systems.

III. PROPOSED FRAMEWORK

The proposed model is the two way communication system user can send the voice command to change the state of home appliances and system sends the voice message to inform the user about intrusion.

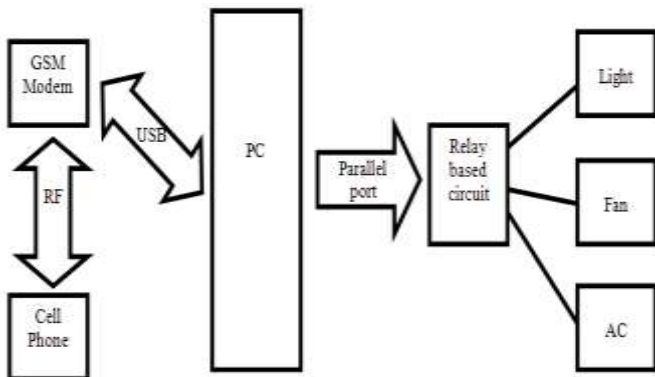

Figure 1: Block diagram of controlling home appliances through voice commands

The block diagram of proposed model is shown in fig. 1. It works in a way that the user with a specific cell number can make a call through GSM technology. System receives the call and performs the respective action as instructed by the user such as controlling the light through relay based circuit. System also sends the voice message to the preconfigured cell number to tell the status of appliances or if it finds any kind of intrusion at home.

A. hardware design

USB voice GSM modem is used to send the return voice message to preconfigured number. Voice GSM is used to send the wav file to preconfigured number through AT commands.

A relay based circuit is used to control the appliances this circuit is attached with system through DB-23 male parallel port [9]. The circuit diagram is shown in fig. 2

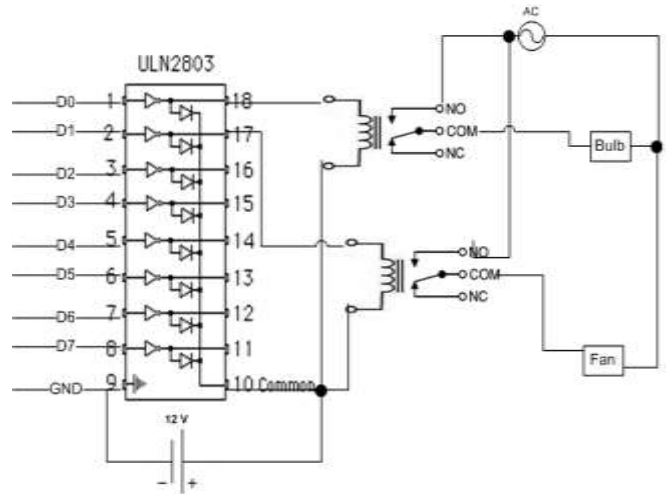

Figure 2: circuit diagram

Two relays are used to control two appliances but as there are eight data pins of parallel port so relays can be increased to control up to eight appliances. 12 volt adapter is used to give voltage to relay. An IC ULN2803 is used to interface the relay with parallel port. It is 18 pin IC whose 1 to 8 pins are data pins and 18 to 11 are corresponding output pins, pin 9 in ground and 10 is supplied with required voltage here it is supplied with 12 volts.

B. software design

This application is develop in .Net framework using the language C#. Microsoft speech SDK 5.0 is used for speech reorganization purpose.

This application has three main parts. One is to understand the speech or the voice of user. This is done through speech reorganization engine. There are many speech reorganization engines available but here Microsoft speech SDK5.1 is used. Second is to control the appliances according to the user demand. This can be done through relay based circuit that is attached with computer through parallel port. And third is to sense the intrusion in the home and sends voice message to preconfigured number. This can be done through sensors attach to the system with parallel port and AT commands respectively.

C. System overview

User from anywhere being GSM available can make a call to system to check the status of appliances or control them as describe in fig 3(a). System in return checks the authenticity of the number and if it is from the preconfigured number then it follows the instruction otherwise it discard the call. As computer receives a call timer starts and it automatically discard the call after few seconds. The voice is understood by the Microsoft speech reorganization engine that is installed in the system. If the command is about changing the status of appliances it passes the signal to parallel port to follow the instruction like turn the appliances on or off. This can be done through relay based circuit. If command is to check the status of appliances the system returns the voice message to preconfigured number using AT Commands telling the status of appliances.

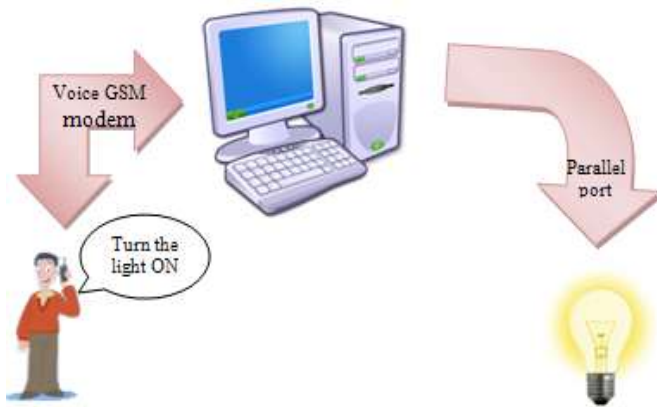

Figure 3(a): System overview

On the other hand if system finds any kind of intrusion like opening of entrance door etc in the home it sends the voice message to user telling him about the intrusion as describe in fig 3(b).

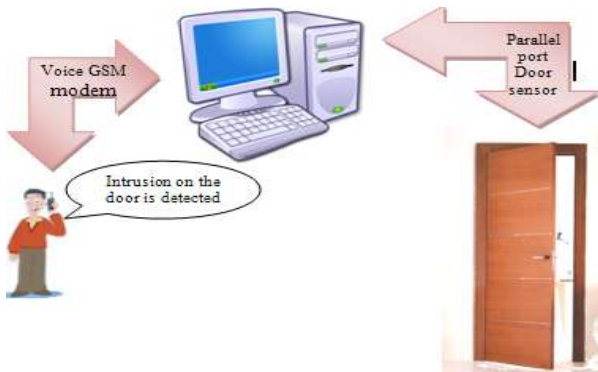

Figure 3(b): system overview

IV. PROPOSED TECHNIQUE

The proposed technique is simple and cost effective and is available to almost every one. The proposed system is given in Fig. 1 shows that GSM technology and voice messages and calls are used in the system and a relay based circuit is attach to the pc through parallel port. It enables the user to control home appliances such as turning the light on or off remotely. It detects the intrusion also.

Algorithm:

Pseudo code of proposed model is given in fig.4

```

Begin
If hardware test fails
Return
End
Else if hardware tests succeed then
Successful communication
If system gets a call
Check the authenticity
If call not from the preconfigured number
Aboard the call
Else
Receive the call and listen the command
If command is about controlling the appliances
Send the signal to parallel port and control them
sends the respective voice message
If command is about knowing the status of appliances
Check the parallel port status of appliances and
sends the status to that number
If system sense some intrusion in the home
Return the voice message to preconfigured number
End
    
```

Figure 4: Algorithm of controlling home appliances through voice commands

Test Case 2

Title: Check the authenticity of number.

System: Home Appliance Control System (HACS).

Input Instructions: make a call from any number.

Output: the system did not receive the call and discard it.

Result: Test Succeeded.

Test Case 3

Title: Check for Light Control.

System: Home Appliance Control System (HACS).

Input Instructions: make a call from preconfigured number and ask to turn the light on.

Output: the light turns on and a confirmation voice message is received on the number

Result: Test Succeeded.

Test Case 4

Title: Check for fan Control.

System: Home Appliance Control System (HACS).

Input Instructions: make a call from preconfigured number and ask to turn the fan on.

Output: the fan turns on and a confirmation voice message is received on the number.

Result: Test Succeeded.

Test Case 5

Title: Check for fan Control.

System: Home Appliance Control System (HACS).

Input Instructions: make a call from preconfigured number and ask to turn the fan off.

Output: the fan turns off and a confirmation voice message is received on the number.

Result: Test Succeeded.

Test Case 6

Title: Test for Security Check.

System: Home Appliance Control System (HACS).

Input Instructions: sensors sense the light.

Output: the light sensor turns red and a voice command is received alerting about intrusion at home on user cell phone.

Result: Test Succeeded

A. Graph of experimental results:

As user makes a call to the system the timer starts and when user says a command regarding the appliances the system match the command with its vocabulary if it finds match it follows the instruction. If the timer exceeds from certain limit the system discard the call or if system does not find the match it sends the message to preconfigured number "sorry could not understand your message".

B. Comparison of proposed system with other systems:

The graphs of average response time of appliances and intrusion are given. These have been taken from the test cases given above.

As soon as the system receives the voice command from the preconfigured cell phone number regarding any appliances like light, AC or Fan to change the status of them or to know the current status of them the system response in 4, 6 and 3.5 seconds respectively. This is the average response time of appliances. Graph of response time of appliances like light, AC and fan are shown in the fig 3.

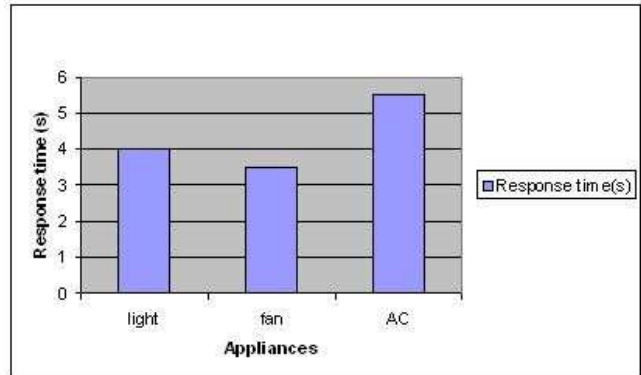

Figure 5: average response time of appliances

As soon as the system senses the intrusion through sensors attach with it, on the Main gate, Living room window or Entrance door it sends the signal to computer and computer then sends a voice message to the preconfigured cell phone number in 3.6, 4 and 3.9 seconds respectively. This is the average intrusion detection time in the home.

Graph of response time of intrusion deduction in the home is shown in the fig 4.

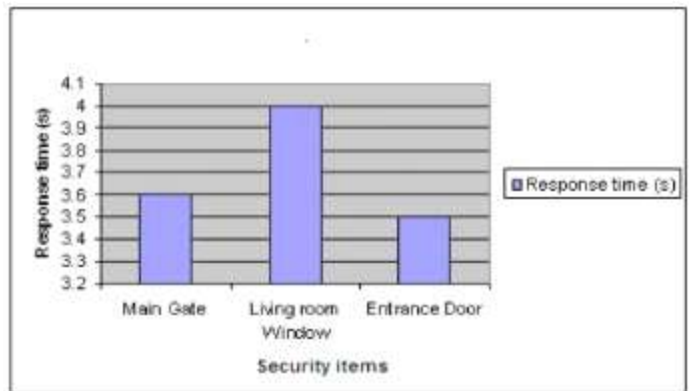

Figure 6: Average intrusion deduction time

TABLE 1: COMPARISON OF SYSTEMS

No.	System	Technique	characteristics		
			Cost effective	highly Accessible	security
1.	Ubiquitous Access to Home Appliance Control System using Infrared Ray and Power Line Communication [1]	Power Line Communication (PLC),IR	No	Yes	available
2.	Remote Control using Mobile through Spoken Commands [5]	GSM technology	Yes	No	Not available
3.	Friendly Home Automation System Using Cell Phone and J2ME with Feedback Instant Voice Messages[6]	GSM technology	Yes	Yes	available
4.	Homes Appliances Controlled Using Speech Recognition in Wireless Network Environment[7]	wireless technology	No	No	Not available
5.	Proposed System	Voice GSM technology, AT command	Yes	Yes	available

The comparison of different systems with proposed system is given in table 1. Proposed system is using voice GSM technology and AT commands for sending and receiving the voice command to control the home appliances. This is cost effective and provides security and is highly accessible. While the other system [1] is not cost effective and [5] does not provide security and every where access. In [6] the system is proposed that controls the home appliances remotely. Two cell phones are used for communication. This system is developed by using the J2ME language. The system [7] is not cost effective since it uses the internet for communication.

V. CONCLUSION

Controlling home appliances with wireless technology has revolutionized our way of living. Home owners can come to an ideal environment coming from their daily activities. Technique used in this system is not complex. It is the location independent system being GSM available for the ease of user. In future many more features can be added in it like home appliances can be controlled by using voice call by implementing more secure and efficient techniques.

REFERENCES

- [1] Tam Van Nguyen, Dong Gun Lee, Yong Ho Seol, Myung Hwan Yu, Deokjai Choi, "Ubiquitous Access to Home Appliance Control System using Infrared Ray and Power Line Communication", ICI 2007, 3rd IEEE/IFIP International Conference in Central Asia, Tashkent, Uzbekistan, vol 1, pp1-4,26-28 Sept.2007
- [2] S. M. Anamul Haque, S. M. Kamruzzaman and Md. Ashraful Islam1 "A System for Smart-Home Control of Appliances Based on Timer and Speech Interaction" Proceedings of the 4th International Conference on Electrical Engineering & 2nd Annual Paper Meet 26-28 , pp. 128-131,January, 2006
- [3] Malik Sikandar Hayat Khoyal, Aihab Khan, and Erum Shehzadi "SMS Based Wireless Home Appliance Control System (HACS) for Automating Appliances and Security". Issue in Information Science and Information Technology Vol 6., Pp 887-894, 2009.
- [4] Jia-Ren Chang Chien, Cheng-Chi Tai "The Information Home Appliance Control System—A Bluetooth Universal Type Remote Controller" Proceedings of the 2004 IEEE. International Conference on

Networking, Sensing & Control. Taipei, Taiwan, vol. 1,pp. 399-400, March 21-23. 2004

- [5] N.P.Jawarkar, Vasif Ahmed and R.D. Thakare. "Remote Control using Mobile through Spoken Commands". IEEE - International Consortium of Stem Cell Networks (ICSCN) 2007. 22-24,Pp.622-625, 2007
- [6] Mahmoud shaker Nasr, Fahtha H. A.salem Azwai, "Friendly home automation system using cell phone and J2ME with feedback instant voice messages," aiccsa, 2009 IEEE/ACS International Conference on Computer Systems and Applications, pp.531-538,2009
- [7] Mardiana B., Hazura H., Fauziyah S., Zahariah M., Hanim A.R., Noor Shahida M.K., "Homes Appliances Controlled Using Speech Recognition in Wireless Network Environment," ICCTD, vol. 2, pp.285-288, 2009 International Conference on Computer Technology and Development, 2009
- [8] Yoshiro Imai, Yukio Hori, Shin'ichi Masuda, "A Mobile Phone-Enhanced Remote Surveillance System with Electric Power Appliance Control and Network Camera Homing," ICAS, pp.51, Third International Conference on Autonomic and Autonomous Systems (ICAS'07), 2007
- [9] <http://jaspreetscodezone.blogspot.com/2008/01/interfacing-relays-using-parallel-port.html>

AUTHOR'S PROFILE

Marriam butt is a graduate from Dept. of Software Engineering, Fatima Jinnah Women University, Pakistan.

Mr.Aihab Khan works in Dept. of Computer Sciences at Fatima Jinnah Women University, Pakistan. His research interests are in the field of Data Mining, Data Warehousing as well as Information security.

Dr. M. Sikandar H. Khoyal born at Khushab, Pakistan. He is Chairperson Dept. Computer Sciences and Software Engineering in Fatima Jinnah Women University Pakistan. He served in Pakistan Atomic Energy Commission for 24 years and involved in different research and development program of the PAEC. He developed software of underground flow and advanced fluid dynamic techniques. He was also involved at teaching in Computer Training Center, PAEC and International Islamic University. His area of interest is Numerical Analysis of Algorithm, Theory of Automata and Theory of Computation. He has more than one hundred research publications published in National and International Journals and Conference proceedings. He has supervised more than one hundred and thirty research projects at graduate and postgraduate level. He is member of SIAM, ACM, Informing Science Institute, IACSIT. He is Co editor of the journals JATIT and International Journal of Reviews in Computing and associate editor of IJCTE. He is reviewer of the journals, IJCSIT, JIISIT, IJCTE, IJCEE, JCIE and CEE of Elsevier.