

Lawrence Berkeley National Laboratory

Recent Work

Title

Coupling indoor airflow, HVAC, control and building envelope heat transfer in the Modelica Buildings library

Permalink

<https://escholarship.org/uc/item/8xx161c8>

Journal

Journal of Building Performance Simulation, 9(4)

ISSN

1940-1493

Authors

Zuo, W
Wetter, M
Tian, W
[et al.](#)

Publication Date

2016-07-03

DOI

10.1080/19401493.2015.1062557

Peer reviewed

Coupling Indoor Airflow, HVAC, Control and Building Envelope Heat Transfer in the Modelica Buildings Library

Wangda Zuo¹, Michael Wetter², Wei Tian¹, Dan Li¹, Mingang Jin³, Qingyan Chen^{3,4}

1. Department of Civil, Architectural and Environmental Engineering, University of Miami, Coral Gables, FL 33146, USA

2. Building Technology and Urban Systems Division, Lawrence Berkeley National Laboratory, Berkeley, CA 94720, USA

3. School of Mechanical Engineering, Purdue University, West Lafayette, IN 47905, USA

4. Tianjin Key Lab of Indoor Air Environmental Quality Control, School of Environmental Science and Engineering, Tianjin University, Tianjin 300072, China

This paper describes a coupled dynamic simulation of indoor environment with HVAC systems, controls and building envelope heat transfer. The coupled simulation can be used for the design and control of ventilation systems with stratified air distributions. Those systems are commonly used to reduce building energy consumption while improving the indoor environment quality. The indoor environment was simulated using the fast fluid dynamics (FFD) simulation program. The building fabric heat transfer, HVAC and control system were modelled using the Modelica *Buildings* library. After presenting the concept, the mathematical algorithm and the implementation of the coupled simulation were introduced. The coupled FFD-Modelica simulation was then evaluated using three examples of room ventilation with complex flow distributions with and without feedback control. Further research and development needs were also discussed.

Keywords: FFD, Modelica, Coupled Simulation, Building Energy Simulation

1. Introduction

Ventilation systems with non-uniform air distributions are common in buildings with large spaces, such as theatres and auditoria, buildings with non-uniform heat generation, such as data center rooms, and buildings with displacement ventilation, natural ventilation, and hybrid ventilation. One can use computer simulations of the indoor environment and ventilation system to explore different system design and control strategies. Building energy simulation (BES) tools, such as EnergyPlus (Crawley et al. 2001), can simulate the building ventilation performance. However, those BES tools often adopt multizone airflow network models which are based on the well-mixed assumption, which are not suitable for simulating ventilation systems with non-uniform air distributions (Gu 2007; Wang and Chen 2007). To address this limitation, coupled simulations between BES and computational fluid dynamics (CFD) tools were proposed to study the energy performance for buildings with stratified air distributions. For instance, Zhai et al. (2002) found that there was a considerably large difference in predicting the cooling load for an auto racing complex between a standard BES using the multizone airflow network model and a coupled BES and CFD. Zhang et al. (2013) studied the performance of natural ventilation by coupling BES and CFD. Fan et al. (2012) investigated the performance of energy recovery ventilator in a real office with coupled simulation of BES and CFD. More details about the coupled BES and CFD simulation can be found at a recent literature review (Tian and Zuo 2013).

Unfortunately, none of the above coupled simulation of BES and CFD can be used to perform controls evaluation for the feedback control of building ventilation systems due to the limitations of the conventional BES and CFD tools. First, conventional BES tools, such as EnergyPlus, are designed for a whole building energy performance simulation over a long period. To reduce the computing time, those tools

often use idealized controls and there is no local feedback control implemented.

Therefore, those BES tools cannot be used for the design and evaluation of ventilation systems with local feedback control.

Second, conventional CFD tools are too slow to perform unsteady simulations for a room in real time or faster-than-real-time. Instead, most coupled BES-CFD simulations usually perform only a few steady-state CFD simulations to compute the indoor environment, assuming the indoor environment does not change over a long period. This strategy is appropriate for estimating building energy performance with limited computing time. However, using only a few steady-state CFD simulations is not appropriate for the design and optimization of an HVAC control for a stratified indoor environment as it does not account for the dynamics of the feedback control.

The contribution of this research is to develop a coupled dynamic simulation that can simulate the dynamic interaction between the room airflow, HVAC, building envelope and feedback control. By simulating the dynamic process of the ventilation control, the coupled simulation can realistically represent the behaviour of the building ventilation system with feedback control. Therefore, the coupled simulation can be used for the controls design and evaluation to improve the performance of building ventilation.

To implement the coupled simulation, we selected a Modelica modelling language (Fritzon 1998) to model the building envelope, HVAC system, and feedback control. Modelica is an equation-based, object-oriented modelling language for the simulation of multi-domain dynamic systems. In this study, our implementation was done based on the Modelica *Buildings* library (Wetter et al. 2014), which is an open-source, freely available Modelica library for building energy and control systems. The Modelica *Buildings* library has been used for the design and performance evaluation of

various building energy and control systems (Kim et al. 2013; Ansuini et al. 2012; Zuo and Wetter 2011; Huang and Zuo 2014).

For the indoor environment simulation, we choose the Fast Fluid Dynamics (FFD) program (Zuo and Chen 2009; Jin, Zuo, and Chen 2012b) written in the C language. The FFD solves the same Navier-Stokes equation and other governing equations as CFD does. However, by employing different numerical algorithms and sacrificing some accuracy, FFD simulations have been shown to be around 50 times faster than their CFD counterparts (Zuo and Chen 2009). In addition, parallel computing on a graphics processing unit further accelerates the FFD (30 times faster) (Zuo and Chen 2010a). Consequently, this results in a total speedup of 1,500 times faster than CFD (Zuo and Chen 2010a). The FFD program has been validated and used to study various airflows inside and around buildings (Zuo and Chen 2010c, 2010b; Jin, Zuo, and Chen 2013; Jin, Chen, and Zuo 2013; Jin, Zuo, and Chen 2012a; Zuo and Chen 2007). At the same time, other researchers also implemented the coupled FFD-Modelica simulation based on the Aachen Room models (Flieger et al. 2014).

This paper is structured as follows: The next section introduces the mathematical algorithms for data exchange in the coupled simulation between the FFD program and the Modelica *Buildings* library. We present the implementation of the FFD programs and Modelica models. Next, the accuracy is quantitatively evaluated using a case of mixed convection and qualitatively studied using the other two cases with feedback control. We also measured the computing time for all three cases.

2. Mathematical Algorithms for Data Exchange

2.1. Data Synchronization

To exchange the data between FFD and Modelica during the coupled simulation, we

used a data synchronization strategy with a zero-order hold of the respective input signals. The zero-order hold means that the program holds the received data constant until the next synchronization time step. To reduce the computing time, the data exchange is performed only once for every synchronization. This synchronization strategy is semantically equivalent to the one used by the Building Controls Virtual Test Bed (BCVTB) (Wetter 2011). The BCVTB is a middleware used to facilitate the data exchange between two programs while we, on the other hand, applied direct data exchanges to reduce the overhead of passing information through the middleware.

Figure 1 illustrates our data synchronization strategy. At time step t_n , FFD sends data $x_1(t_n)$ to Modelica and Modelica sends data $x_2(t_n)$ to FFD. The $x_1(t_n)$ and $x_2(t_n)$ are then kept constant in each program that receives the data until the next synchronization point. Each program may use smaller time step sizes (Δt_{ffd} or Δt_{mod}) for its own integration between synchronization points. It is possible that Δt_{mod} will vary during the simulation since it is determined by an adaptive time step integration algorithm.

The above data synchronization strategy was implemented in the FFD program and the Modelica *Buildings* library using a master-slave method. The Modelica is the master of the coupled simulation and FFD is the slave. Modelica defines the coupled simulation period and the next synchronization point. It also launches and terminates the FFD simulation.

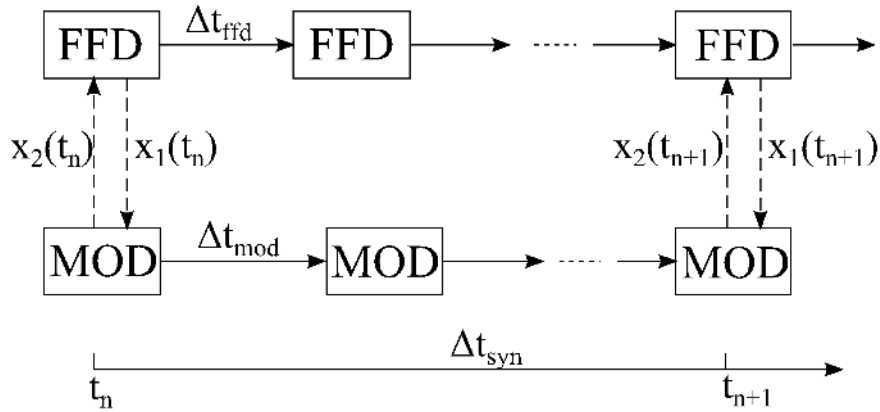

Figure 1. Data synchronization between FFD and Modelica.

2.2. Exchanged Physical Quantities

This section describes the exchanged physical quantities between the FFD program and the Modelica models. Compared to coupling the CFD and conventional building energy simulation programs, a major challenge of coupling FFD and Modelica models is that in Modelica, flow directions in the HVAC system can reverse based on the computed pressure difference. Therefore, an air inlet in FFD may become an outlet if the room pressure is higher than the supply air duct pressure, and vice-versa. Thus, the FFD program has to be able to change boundary conditions for the inlet and outlet during the simulation. This is achieved by two steps: First, the FFD program checks the newly received mass flow rates at all inlets and outlets at the synchronization point. Second, the FFD sets the “inlet” boundary condition for those having positive mass flow rates and the “outlet” for those with negative values. The new boundary conditions are then applied to the FFD simulation until next synchronization point. The following part presents the detailed implementation.

2.2.1. Fluid Ports

In the Modelica *Buildings* library, the fluid flow into and out of models is modelled

using fluid ports. These fluid ports include variables for pressure, mass flow rate, enthalpy, mass fractions (such as water vapour), and optional trace substances (such as carbon dioxide) that are carried by the mass flow. The fluid ports in the Modelica models correspond to the inlet and outlet boundaries in FFD. The Modelica fluid port implementation allows the direction of the mass flow to reverse in order to satisfy the pressure and flow equations. Therefore, in the FFD program, air inlets or outlets need to be dynamically assigned according to the direction of the flow during the coupled simulation.

For the inlet fluid port, the Modelica model defines inlet boundary conditions for FFD. At the time of the data exchange, t_n , FFD converts the averaged mass airflow rate at the inlet received from Modelica to the inlet velocity $u_{in}(t_n)$. FFD assumes a uniform velocity distribution on the inlet surface. Hence

$$u_{in}(t_n) = \frac{1}{\rho S_{in} \Delta t} \int_{t_{n-1}}^{t_n} \dot{m}_{in}(t) dt, \quad (1)$$

where ρ is the fluid density, S_{in} is the inlet surface area, and $\Delta t = t_n - t_{n-1}$ is the time interval between two data exchanges. In addition, Modelica sends FFD the temperature, concentration of species, and trace substances at the inlet by using their corresponding time-averaged quantities at the Modelica fluid ports.

For the outlet fluid port, FFD defines the boundary conditions for the Modelica models. The FFD computes a time averaged mass flow rate as

$$\dot{m}_{out}(t_n) = \frac{\rho}{\Delta t} \int_{t_{n-1}}^{t_n} \int_{S_{out}} u_n(s, t) ds dt, \quad (2)$$

where $u_n(s, t)$ is the velocity normal to the mesh surface s at the outlet and S_{out} is the

total outlet area. The time averaged air temperature at the outlet $T_{out}(t_n)$ is computed as

$$T_{out}(t_n) = \frac{\rho}{\dot{m}_{out}(t_n)\Delta t} \int_{t_{n-1}}^{t_n} \int_{S_{out}} u_n(s, t) T(s, t) ds dt, \quad (3)$$

where $T(s, t)$ is the air temperature on the mesh surface. Other scalar variables, such as mass fraction and trace substances concentration, are calculated similarly.

2.2.2. Walls and Windows

For the FFD simulation, thermal boundary conditions of solid surfaces, such as surfaces of walls and windows, can either be a given temperature or a given heat flux. In our implementation, if Modelica provides to FFD the time-averaged temperature of an solid surface $T_{sur}(t_n)$ as

$$T_{sur}(t_n) = \frac{1}{\Delta t} \int_{t_{n-1}}^{t_n} T(t) dt, \quad (4)$$

FFD will compute the surface heat flux $\dot{q}_{sur}(s, t)$ and provide Modelica the heat flow rate $\dot{Q}_{sur}(t_n)$ as

$$\dot{Q}_{sur}(t_n) = \frac{1}{\Delta t} \int_{t_{n-1}}^{t_n} \int_{S_{sur}} \dot{q}_{sur}(s, t) ds dt. \quad (5)$$

Alternatively, if Modelica computes the time-averaged heat flow rate $\dot{Q}_{sur}(t_n)$ as

$$\dot{Q}_{sur}(t_n) = \frac{1}{\Delta t} \int_{t_{n-1}}^{t_n} \dot{Q}_{sur}(t) dt, \quad (6)$$

FFD will convert it to a heat flux $\dot{q}_{sur}(t_n)$ using

$$\dot{q}_{sur}(t_n) = \frac{\dot{Q}_{sur}(t_n)}{S_{sur}}. \quad (7)$$

In addition, FFD computes the time-and-surface-averaged temperature $T_{sur}(t_n)$ as

$$T_{sur}(t_n) = \frac{1}{\Delta t} \int_{t_{n-1}}^{t_n} \frac{1}{S_{sur}} \int_{S_{sur}} T(s, t) ds dt. \quad (8)$$

2.2.3. Sources

For internal heat sources, our current implementation assumes that the heat flow rate $\dot{Q}_{sou}(t_n)$ that is injected into the space to be uniformly distributed. Hence, the heat flow rate in FFD is

$$\dot{q}_{sou}(t_n) = \frac{\dot{Q}_{sou}(t_n)}{V}, \quad (9)$$

where V is the volume of the room air.

Furthermore, if a heat source needs to be modelled at a certain location, such as for computing the plume caused by a person, we can use one or several surfaces and prescribe their temperature or heat flux as described in the previous section.

2.2.4. Sensors

FFD allows users to add “virtual sensor” to get the information such as temperature, flow velocity and contaminant concentration at any user defined location (e.g. the room center) or space (e.g. the room or the occupied zone). The value can be instantaneous or time-averaged. By default, the standard FFD sensor output provides the time and

volume averaged room air temperature to Modelica as

$$T_{room}(t_n) = \frac{1}{V_{room}\Delta t} \int_{t_{n-1}}^{t_n} \int_{V_{room}} T(V, t) dV dt. \quad (10)$$

Users can also add their own sensors by adding codes to the FFD program. For instance, FFD can send to Modelica the average temperature of the occupied zone defined as

$$T_{occ}(t_n) = \frac{1}{V_{occ}\Delta t} \int_{t_{n-1}}^{t_n} \int_{V_{occ}} T(V, t) dV dt, \quad (11)$$

where V_{occ} is the volume of a user-defined occupied zone.

3. Implementation

3.1. Implementation in the Modelica Buildings Library

The Modelica *Buildings* library version 1.6 couples the well-mixed indoor environment and the HVAC system through the connection of fluid ports and/or heat ports of the room model and HVAC component models. The room model named *Rooms.MixedAir* simulates the indoor environment with the assumption of completely mixed air. This model can have any number of constructions and surfaces that participate in the heat exchange through convection, conduction, infrared radiation and solar radiation. The model *Rooms.MixedAir* and its window model have been validated (Nouidui et al. 2012; Nouidui, Wetter, and Zuo 2012). Based on the existing *Rooms.MixedAir* model, we introduced the new *Rooms.CFD* model to compute the room air using coupled simulation with CFD/FFD. The term ‘‘CFD’’ is used in the related Modelica model names because most of the implementation in the Modelica models can be also used for

coupled simulation with other CFD programs.

As shown in Figure 2, the model icons of the *Rooms.MixedAir* and *Rooms.CFD* models are similar. This model similarity allows users to easily switch the two room models for different modelling purposes. For instance, *Rooms.MixedAir* can be used during a preliminary design to reduce the computing time. Subsequently, during a detailed design, one can replace the *Rooms.MixedAir* model by *Rooms.CFD* to increase accuracy. It is worth to note that there are two differences in the model icons between *Rooms.MixedAir* and *Rooms.CFD*. One is that *Rooms.CFD* does not have the input for the shading control signal because a movable shade would require the CFD/FFD program to change the surface area of the boundaries for the shaded and unshaded window during the simulation which is not implemented in FFD. Thus, modifications will be needed to use the current *Rooms.CFD* model to simulate the room airflow with shading control. The other is that *Rooms.CFD* has extra outputs *yCFD* for output sensor data as discussed in section 2.2.4.

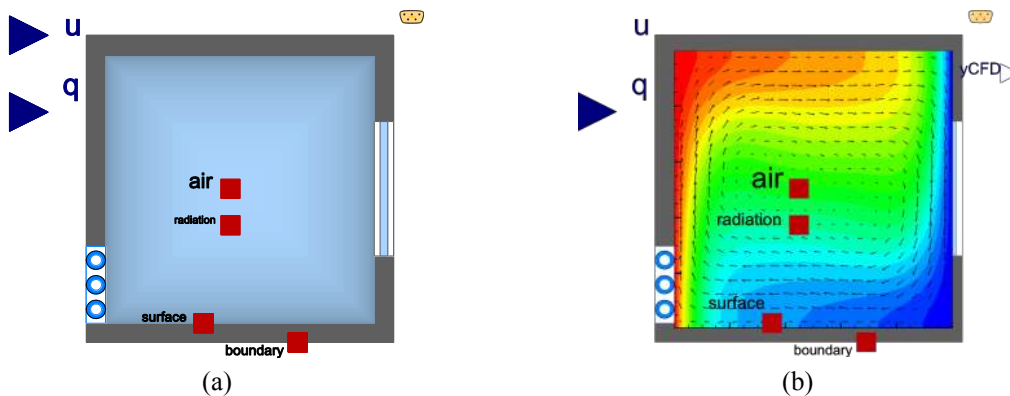
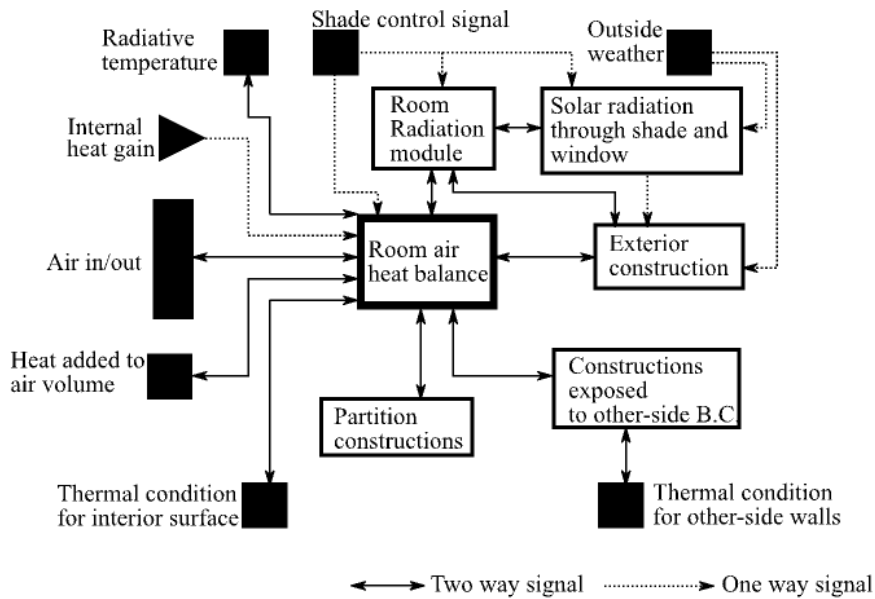

Figure 2 Icons of the two room models (a) *Rooms.MixedAir* and (b) *Rooms.CFD*.

Figure 3 shows the schematic and Modelica implementation of the model *Rooms.CFD* that is extended from *Rooms.BaseClasses.RoomHeatMassBalance*. The *RoomHeatMassBalance* model is largely based on the room model described by Wetter

et al. (2011) However, it was redesigned to be a based model for both *Rooms.MixedAir* and *Rooms.CFD*. The major modification is to model the radiative heat balance in the *RoomHeatMassBalance* while computing the convective heat balance using the mixed air model or the CFD/FFD model, as they use different approaches to calculate the convective heat flow rate.



(a) Schematic

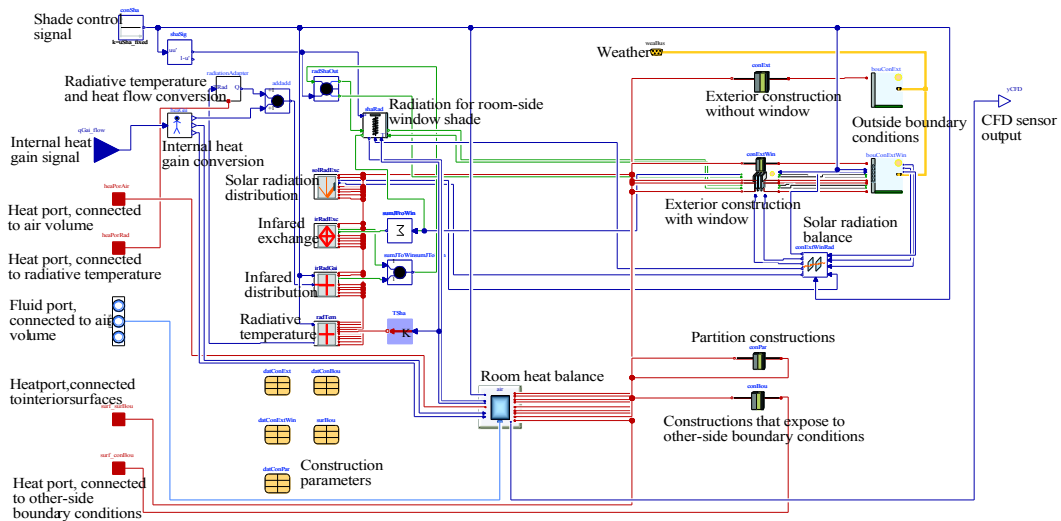

(b) Diagram of the Modelica model

Figure 3 Schematic and diagram of the Modelica model *Rooms.CFD*

The key component of the *Rooms.CFD* model is the model *Rooms.BaseClasses.CFDAirHeatMassBalance* that calculates the heat and mass balance of the air using CFD/FFD. It provides an interface between the causal modelling of CFD/FFD and the acausal modelling of Modelica. As shown in Figure 4, the co-simulation data exchange is managed by a block called *cfid*. To generate inputs and process outputs from the block *cfid*, there is one block named *fluInt* at the bottom center that interfaces the fluid ports. There are also nine blocks on the right that are the interfaces to the heat ports.

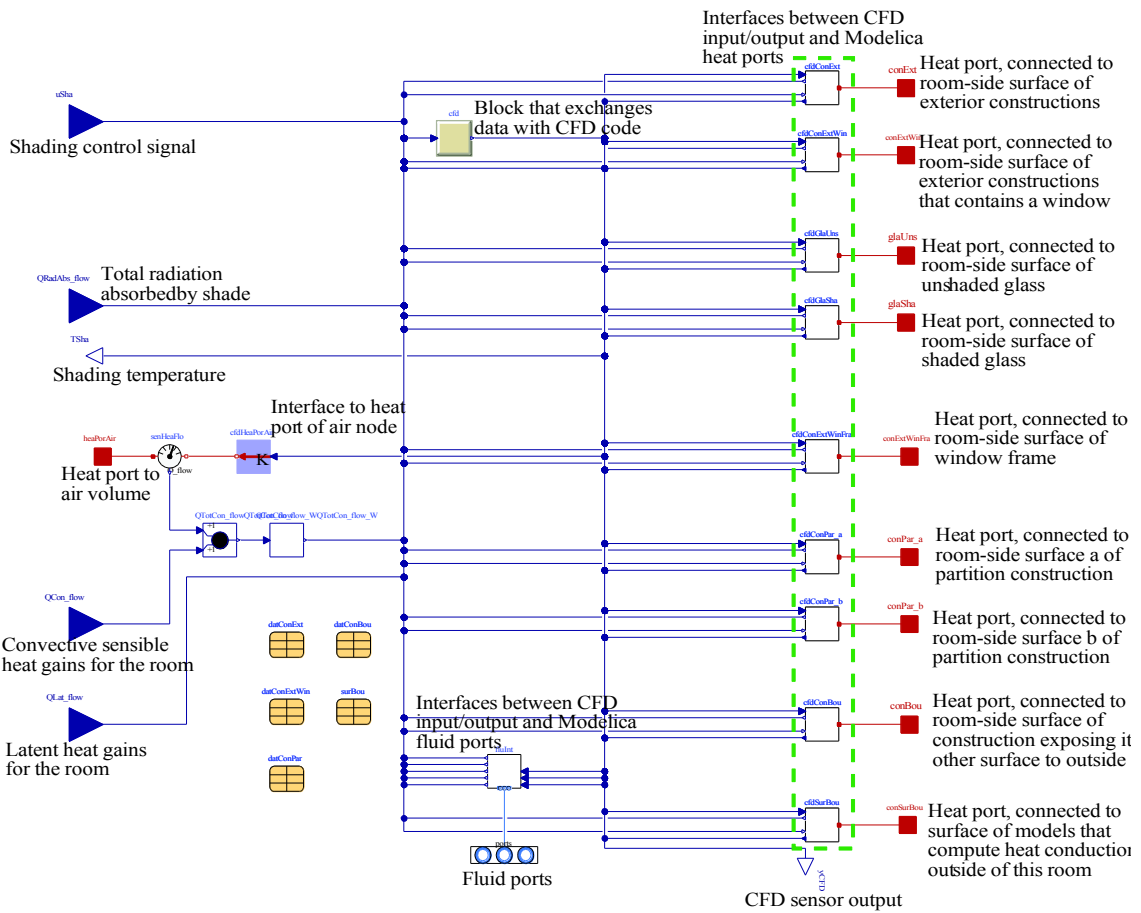

Figure 4 Diagram of Modelica model *Rooms.BaseClasses.CFDAirHeatMassBalance*.

3.2. Implementation in FFD

We also revised the FFD code in order to perform the coupled simulation with

Modelica. The key change is to revise the boundary conditions at FFD so that they can change according to direction of the air flow rate sent by Modelica. As mentioned before, fluid ports in Modelica allow the flow to change direction any time during the simulation. Since the Modelica model defines the inlet and outlet boundary conditions for FFD, it is possible that an inlet will become an outlet or vice versa during the simulation. This is realized by implementing a dynamic flow boundary definition in FFD. Immediately after each data synchronization, the FFD program will reset the inlet and outlet boundary conditions according to the signs of the mass flow rates as received from Modelica. The new boundary conditions will then be used for the FFD simulation until the next data synchronization.

To conduct the coupled simulation, Modelica calls C functions that initiate the FFD simulation, synchronize data during the simulation and terminate the FFD simulation at the end of the coupled simulation. The FFD program is compiled to a dynamically linked library (.dll on Windows or .so on Linux). This library will be loaded by the compiled Modelica code to access the C functions.

4. Case Study

Our previous paper (Zuo et al. 2014) introduced some preliminary work and validated the implementation by simulating simple airflow in an empty room without HVAC equipment and feedback control. This study further improved the implementation and evaluated the performance of the coupled simulation by using more realistic flow conditions and adding a HVAC system and its control. We first quantitatively validated the coupled simulation by modelling ventilation in a space with high air exchange rate and heat load (such as in an aircraft cabin). Then we studied a feedback control for space heating with an idealized HVAC input. After that, we reduced the air exchange

rate and heat load and replaced the idealized HVAC inputs with a constant air volume system to mimic the feedback control of space cooling in an office. To compare the difference in performance, we also simulated the same cases using the standalone Modelica simulation with *Rooms.MixedAir* model.

4.1. Mixed Convection in Space

This case simulates the ventilation for a space (2.44 m × 2.44 m × 2.44 m) with a heated rectangular box (1.22 m × 1.22 m × 1.22 m) inside and its center is located at X = 1.22m, Y = 1.22 m, and Z = 0.61m (Figure 5). The heated box is to mimic a heat source, like occupants. The experiment (Wang and Chen 2009) was designed to study the airflow inside an aircraft cabin with a high internal heat load (about 700 W) and a high air flow exchange rate (ACH = 28.3). The inlet is located on the west wall with a height of 0.03 m and the outlet on the east wall with a height of 0.08 m. The velocity and temperature of the inlet flow are 0.455 m/s and 22.2 °C, respectively. The temperature is 25.8 °C on the ceiling, 26.9 °C on the floor and 27.4 °C on other walls. The temperature on the surface of the box is 36.7 °C. The flow structure is complex because the internal obstacle and the airflow is under the strong interaction of inertia force and buoyance force. The detailed description and experimental data are available in (Wang and Chen 2009).

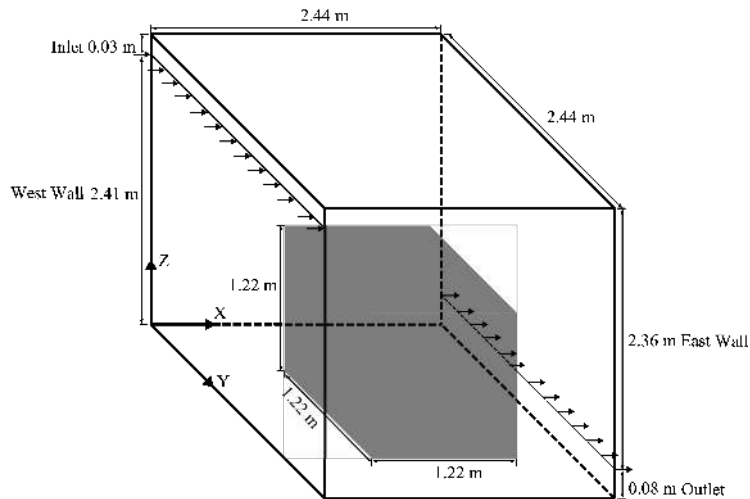

Figure 5 Schematic of the mixed convection in an empty room with a box.

Figure 6 shows the diagram of the Modelica models. In Modelica, we define the wall temperatures and the mass flow rate and temperature of the air into the room. The radiative, convective and latent heat gains were set to zero. For the FFD simulation, a non-uniform $20 \times 20 \times 20$ mesh was used and the time step size was 0.1 s. The data between the two programs was synchronized every 4 s. The same settings of the FFD and data synchronization were applied to all the three cases in the paper.

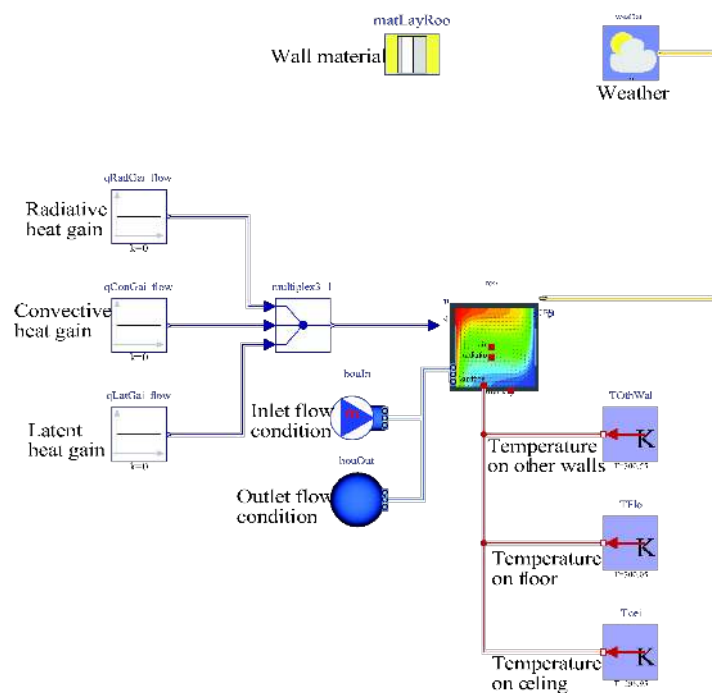

Figure 6 Diagram of Modelica models for the mixed convection.

The detailed experimental data from the floor to the ceiling at ten locations were available (Figure 7). Here we showed the comparison at four locations that were at the front, top, back and side of the box. Figure 8 compares the velocity profiles normalized by a maximum velocity of $U_{\max} = 1.5$ m/s. In general, the FFD prediction agrees with the experimental data. The relatively large discrepancy in prediction at point 5 is due to the complex flow structure that was also discovered in a previous study (Jin, Zuo, and Chen 2012a). It is noteworthy that the studied flow is unstable flow with high turbulence intensity. Even state-of-the-art CFD models could not precisely capture all the flow details (Wang and Chen 2009). Since the FFD is a simplified CFD model, it is not expected to have higher accuracy than state-of-the-art CFD models.

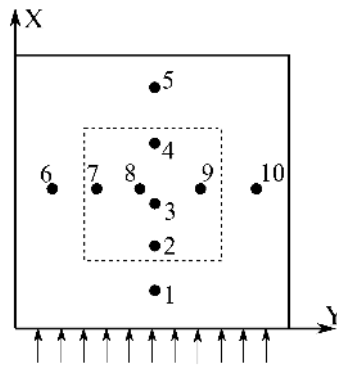

Figure 7 the distribution of ten locations with experimental data available.

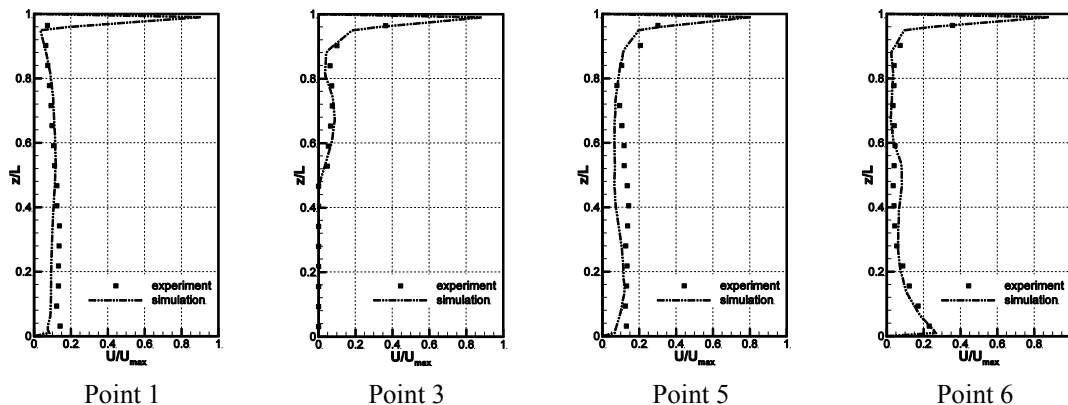

Figure 8 Comparison of normalized velocity profiles calculated by the Modelica-FFD coupled simulation with the experiment data by (Wang and Chen 2009).

Figure 9 compares the temperature profiles calculated by the coupled simulation and the experimental data. The temperature was normalized as

$$T^* = \frac{T - T_{min}}{T_{max} - T_{min}}, \quad (12)$$

where $T_{min} = 22.2$ °C and $T_{max} = 36.7$ °C. FFD made a good prediction for point 1 which is in the front of the box. Due to the impact of box, FFD did not calculate the temperature precisely for the locations behind (point 5) and around the obstacle (point 6). However, it still captured the stratification of the temperature along the line from the floor to the ceiling.

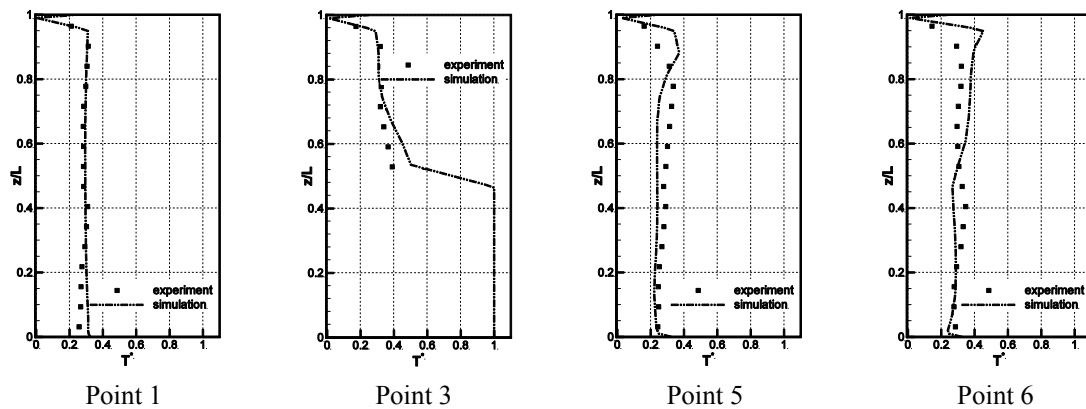

Figure 9 Comparison of normalized temperature profiles calculated by the Modelica-FFD coupled simulation with the experimental data by (Wang and Chen 2009).

Figure 10 shows the side view of velocity vectors and temperature contours on the cross-section at $Y = 1.22$ m computed by FFD. The cold air was injected from the upper-left corner and a circulation was formed between the box and the east wall after the inlet air hit the east wall and then constrained by the box. The thermal plume rose up due to the impact of both buoyance force and air circulation. We put five virtual temperature sensors (s1 to s5) at different locations. The temperatures were then extracted from the FFD simulation and sent to Modelica during the coupled simulation.

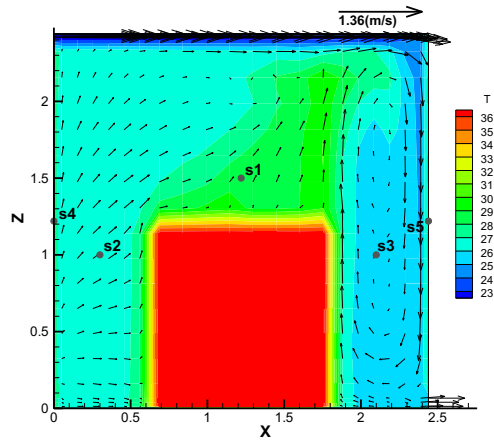

Figure 10 Velocity vectors and temperature contour on a cross-section at $Y = 1.22$ m for the mixed convection.

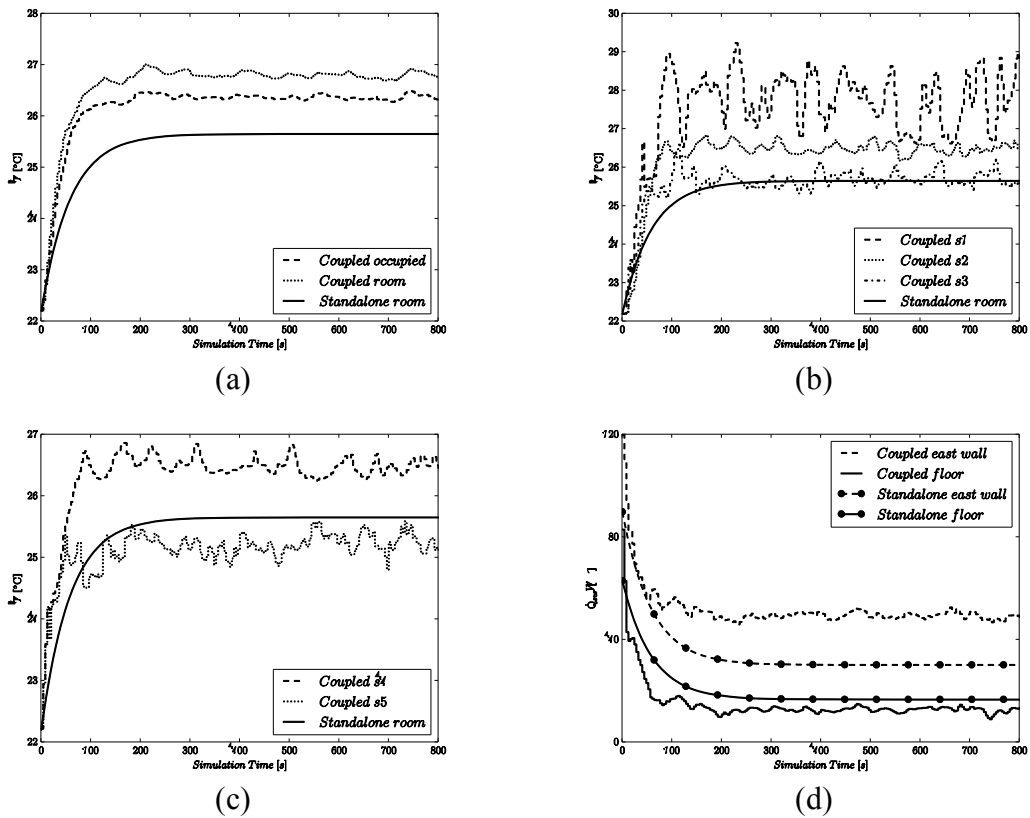

Figure 11 Comparison of the coupled FFD-Modelica simulation and the standalone Modelica simulation for the mixed convection

Figure 11 shows time series from the coupled FFD-Modelica simulation using the *Rooms.CFD* model and the standalone Modelica simulation using the *Rooms.MixedAir* model. Figure 11(a) compares the room temperatures predicted by both simulations and the temperature of the occupied zone ($Z \leq 1.22$ m) by the coupled FFD-Modelica simulation. Ignoring the temperature stratification in the standalone simulation led to the predicted room temperature approximately 1.5 °C lower than the one by the coupled FFD-Modelica simulation. In addition, the FFD-Modelica simulation computed an occupied zone temperature that was lower than the averaged room temperature. Due to the thermal plume generated by the heated box, the temperature at s1 (1.22 m, 1.22 m, 1.5 m), which was above the heated box, was the highest among the temperatures obtained from all five locations (Figures 11 b). Because the box blocked the access of cool air for locations s2 (0 m, 1.22 m, 1.22 m) and s4 (0.3 m, 1.22 m, 1.0 m), they also had higher temperatures than the room temperature computed by the standalone simulation using *Rooms.MixedAir* model. Locating on the path of supplied cool air, s5 (2.44 m, 1.22 m, 1.22 m) had the lowest temperature among the 5 locations (Figure 11c). Due to the dynamic characteristics of the flow, all temperatures showed in the coupled FFD-Modelica simulation were oscillating during the entire simulation although they were fully developed and their time-averaged value were almost constant. This reflects the actual flow condition in the reality. On the other side, the temperature predicted by the standalone simulation reached steady state with a constant value over time after about 300 s.

Figure 11(d) compares the heat flows from the wall to the air. In the coupled FFD-Modelica simulation the heat flow rates were calculated by FFD and passed to the Modelica model *Rooms.CFD*. Both the coupled and standalone simulations showed the declining heat flow rates over time because the room air was heated from a low initial

temperature of 22.2 °C. When the room airflow fully developed, the heat flow rates became almost constant. The coupled FFD-Modelica simulation showed a higher heat flow rate between the east wall and air than the standalone simulation because the coupled simulation captured a layer of cool air near the east wall which the standalone simulation was not capable to predict. Similarly, the coupled simulation also calculated a smaller temperature difference between the floor and air, which then led to a smaller heat flow rate compared to the standalone simulation.

The agreement in prediction between the coupled FFD-Modelica simulation and experimental data shows that the coupled simulation is able to predict the three dimensional distribution of indoor airflow and the difference in the heat exchange with different parts of the building envelope. The next step is to evaluate the coupled simulation using HVAC system with feedback control.

4.2. Feedback Control for Space Heating

In order to illustrate the capability of the coupled FFD-Modelica simulation for ventilation control, we simulated a case with air temperature control for a space under ventilation and heating. The study was based on the previous case with an additional PI control for adding heat uniformly to the space. The control object was to maintain the room temperature at 30 °C. The implementation of the Modelica model is shown in Figure 12.

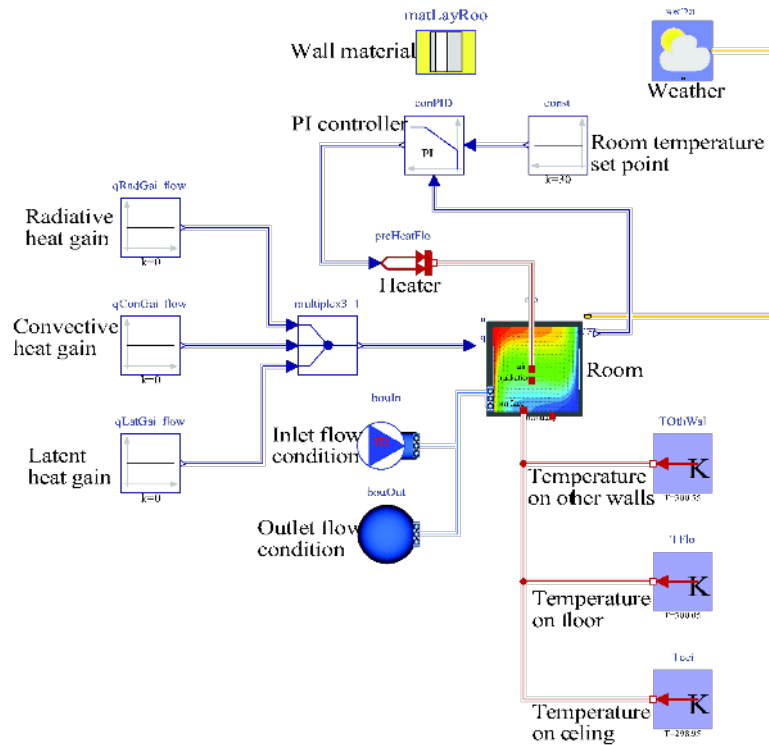

Figure 12 Diagram of Modelica models for space heating.

Figure 13 shows a non-uniform temperature distribution in the room computed by FFD. The temperature of the room air at the lower part (occupied zone) was lower than the upper part. The hottest spots occurred above the heated box. There was also a cold air layer near the ceiling and east wall formed by the cold inlet air.

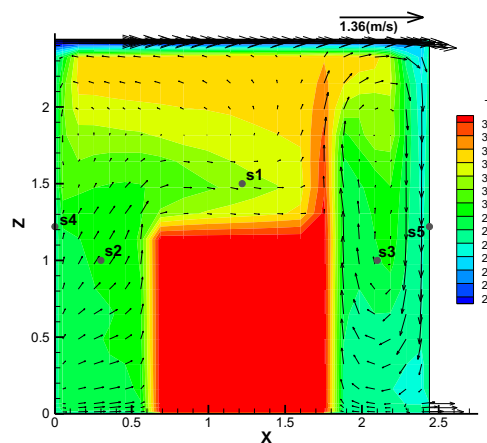

Figure 13 Velocity vectors and temperature contour on a cross-section at $Y = 1.22\text{m}$ for space heating).

As shown in Figure 14(a), the room temperature was maintained at 30 °C in the standalone simulation using *Rooms.MixedAir* model. The coupled FFD-Modelica simulation calculated a transient flow pattern and the controlled temperature was oscillating within ± 1 °C around the set point during the entire simulation. As a response, it was constantly adjusting the injected heat flow in order to maintain the room temperature (Figure 14b). There are three possible causes for the oscillations in temperature and heat injections: First, the airflow is dynamic in nature as discussed in the previous case. Second, synchronizing the sensor data from FFD and the control action from Modelica for every 6 s introduces a delay that may cause instability. Third, the controller is unstable for this process. The coupled simulation predicted temperatures of the occupied zone, s2 and s3 locations (Figure 14c) slightly lower than the average room temperature of 30 °C, which realistically represented the temperature stratification in the space.

The standalone simulation predicted a uniform temperature of 30 °C that was higher than the temperatures of the east wall (27.4 °C) and the floor (26.9 °C). Consequently, it predicted that the heat flow direction was from the air to the wall, as shown in Figure 14(d). In comparison, the coupled FFD-Modelica simulation computed a layer of cold air along the east wall due to the cold inlet air (Figure 13). Therefore, it predicted that the direction of heat flow through the east wall is from the wall to the air, which is opposite to the prediction of the standalone simulation.

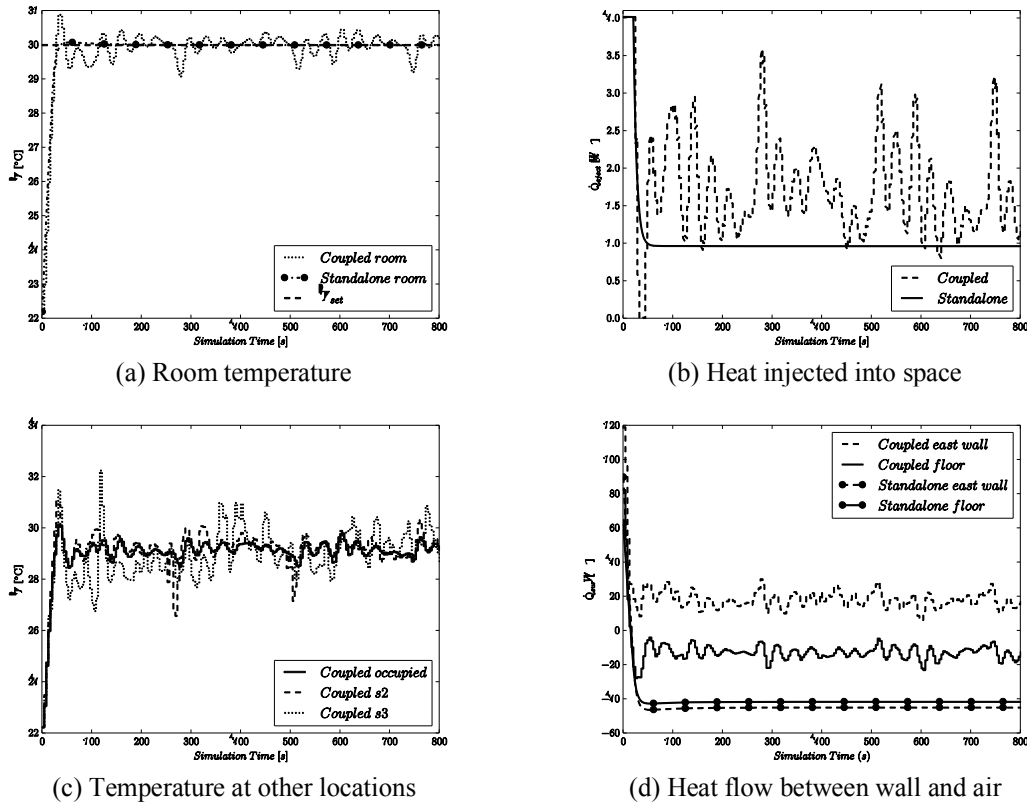

Figure 14 Comparison of the coupled FFD-Modelica simulation and the standalone Modelica simulation for the space heating.

4.3. Feedback Control of Space Cooling

The previous case of space heating control used an idealized HVAC system. In this case, we connected a constant air volume air conditioning system to the room for space cooling. In order to make the flow condition close to an office room, the supply air flow rate was reduced to 5.6 ACH (0.02 m³/s). The surface temperature of the internal box was decreased to 27.4 °C to reduce the internal heat load. As shown in Figure 15, the warm outdoor air was first cooled by the exhaust air through a heat recovery device. Then it was further cooled by chilled water in a cooling coil. The control objective was to maintain the room temperature at a set point of 26 °C. The chilled water supply was controlled by an on-off controller which behaves accordingly based on the difference between set point and measured room temperature. A deadband of 1 K was applied to

avoid short cycling. The simulation was performed for a physical process of 800 s.

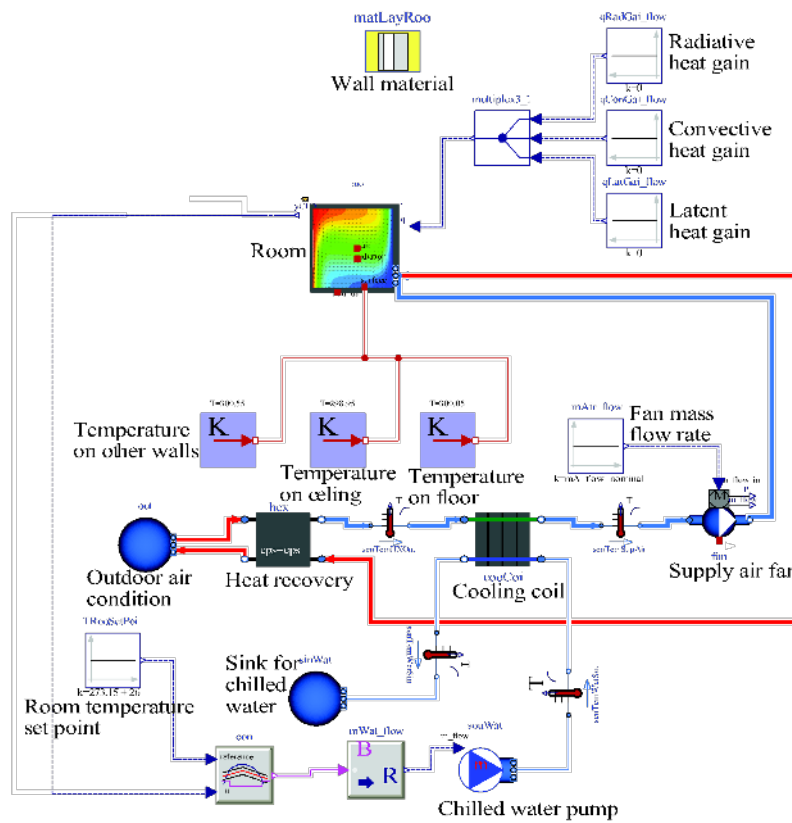

Figure 15 Diagram of Modelica models for space cooling.

Figure 16 shows the results from FFD at 800 s. Cold air was injected into the room through the inlet and sunk into the lower left corner of the room. The upper right corner, since heavily impacted by the thermal plume generated by the heated box and far less affected by the cold airflow air, remained at a higher temperature.

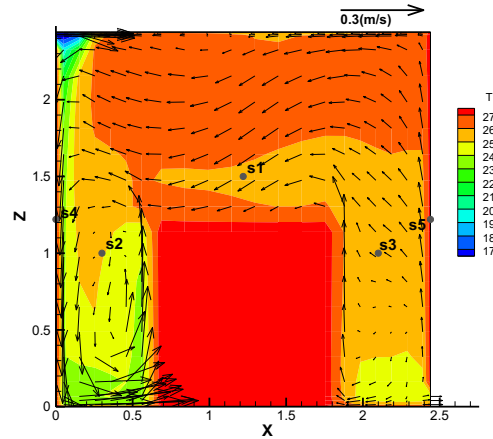
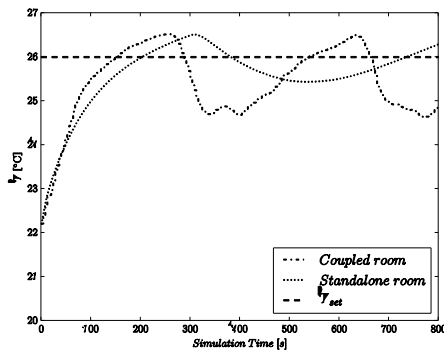

Figure 16 Velocity vectors and temperature contour on a cross-section at $Y = 1.22\text{m}$ for space cooling.

Figure 17(a) shows the room temperatures in both simulations. The room temperature calculated by the standalone simulation using the *Rooms.MixedAir* model was oscillating within $\pm 0.5\text{ }^{\circ}\text{C}$ around the set point. The coupled FFD-Modelica simulation predicted a room temperature varying about $-1.5\text{ }^{\circ}\text{C}$ to $+0.5\text{ }^{\circ}\text{C}$ around the set point. The coupled simulation predicted a quicker rise of the room air temperature than the standalone simulation. As a response, the FFD-Modelica simulation predicted an earlier turning-on for the chilled water valve to cool the supply air than that in the standalone simulation (Figures 17 b and c).

By getting the spatial air temperature distribution for the near wall region, the coupled simulation can better estimate the heat flow rates between the air and wall than the stand-alone simulation (Figure 17a). Based on a uniform room air temperature, the standalone simulation predicted the difference between heat flow rates on the east wall and floor is only due to the difference in the surface temperatures. On the other side, the FFD-Modelica coupled simulation considered that the air temperature near the east wall was actually higher than the one near the floor, so the difference in heat flow rates

through these two surfaces was smaller than the one predicted by the standalone simulation.



(a) Room temperature

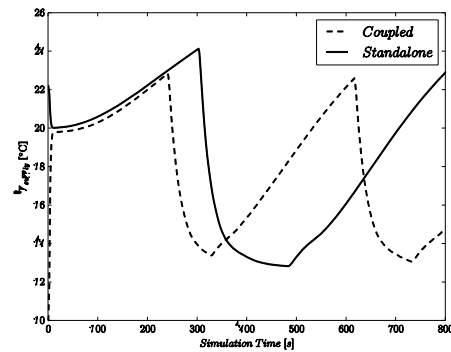

(b) Supply air temperature

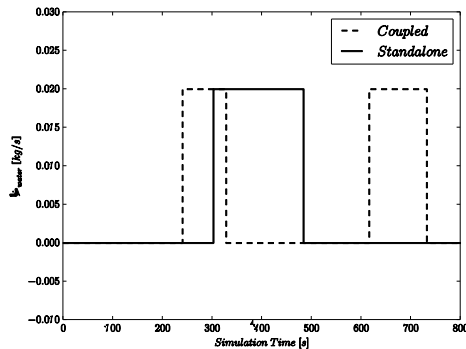

(c) Chilled water flow rate

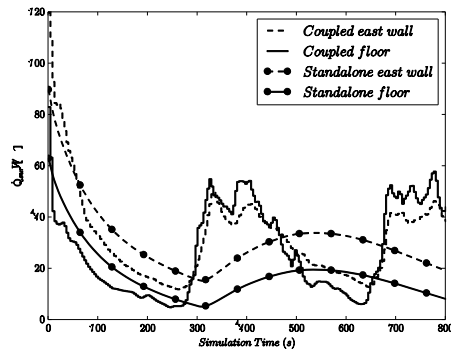

(d) Heat flow rate between wall and air

Figure 17 Temperature at sensor location of room, supply air temperature and chilled water flow rate for the space cooling.

4.4. Computing Time

The Modelica models were simulated using a Modelica simulation environment called Dymola 2015 FD01 (www.dynasim.se). The Radau solver with a tolerance of 10^{-6} in Dymola was applied in all simulations. The simulation was performed using a workstation with an Intel Xeon Processor E5-1603 with a four-core CPU at 2.8 GHz. The results showed that the coupled FFD-Modelica simulation using the *Rooms.CFD* model provided detailed flow information with a significant cost on computing time (about 430 s for each of the three cases) compared to about 0.2 s required by the

standalone simulation using the *Rooms.MixedAir* model. However, the coupled FFD-Modelica simulation was still faster than the real time since the simulated physical process was 800 s.

5. Conclusion

In this study, we implemented and validated a coupled simulation between the FFD and the Modelica Buildings library for the dynamic simulation of building ventilation system with stratified air distributions. The coupled simulation was implemented as a new *Rooms.CFD* model in the Modelica *Buildings* library. For the mixed convection case, the coupled simulation could calculate the air velocity and temperature distribution close to the experimental data. For the cases of space cooling and space heating with feedback control, the coupled FFD-Modelica simulation could also realistically represent the dynamic non-uniform air distributions in the room that was not captured by the standalone Modelica simulation using the *Rooms.MixedAir* model. This difference resulted in different heat exchange rates with building envelopes and different control actions between the coupled and standalone simulations. For the three cases, the coupled FFD-Modelica simulation using the *Rooms.CFD* model was faster than the real time, but significantly slower than the standalone Modelica simulation using the *Rooms.MixedAir* model. Thus, it is recommended to use the standalone Modelica simulation in the preliminary design/evaluation and the FFD-Modelica simulation for the specific room in the detailed design/evaluation if spatial distributions of the air properties are of interest.

The oscillations in indoor air temperature can be attributed to the following factors: frequency of data synchronization in the simulation, which can be a reflection of sensor sampling frequency in a real system; the placement of temperature sensors,

and the tuning of control parameters. With the capability of dynamic simulation of stratified air distribution and HVAC system, our tool provides a more realistic environment for control engineers and researchers to study the control of stratified ventilation systems.

Performing the CFD simulation in parallel using graphics processing units or multicore CPUs could further reduce the simulation time (Zuo and Chen 2010a), although we have not yet implemented this feature in the current work.

Nomenclature

g Acceleration due to gravity

\dot{m} Mass flow rate

\overline{Nu} Averaged Nusselt number

\dot{Q} Heat flow rate

\dot{q} Heat flux

Ra Rayleigh number

S Surface area

T Temperature

t Time

u Velocity

V Volume

β Thermal expansion coefficient

ν Kinematic viscosity

Subscripts:

in Inlet

n Normal to the surface

out Outlet

sur Solid surface

sou Source

Acknowledgments

This research was supported by the Assistant Secretary for Energy Efficiency and Renewable Energy, Office of Building Technologies of the U.S. Department of Energy, under Contract No. DE-AC02-05CH11231.

This work emerged from the Annex 60 project, an international project conducted under the umbrella of the International Energy Agency (IEA) within the Energy in Buildings and Communities (EBC) Programme. Annex 60 will develop and demonstrate new generation computational tools for building and community energy systems based on Modelica, Functional Mockup Interface and BIM standards.

References

Ansuini, R., R. Larghetti, M. Vaccarini, A. Carbonari, A. Giretti, S. Ruffini, H. Guo, and S. L. Lau. 2012. "Hybrid Modeling for Energy Saving in Subway Stations."

- In *Proceedings of the the First Building Simulation and Optimization Conference*, Loughborough, UK.
- Crawley, D. B., L. K. Lawrie, F. C. Winkelmann, W. F. Buhl, Y. J. Huang, C. O. Pedersen, R. K. Strand, R. J. Liesen, D. E. Fisher, and M. J. Witte. 2001. "EnergyPlus: Creating a New-Generation Building Energy Simulation Program." *Energy and Buildings* 33 (4): 319-331.
- Fan, Y. Q., and K. Ito. 2012. "Energy Consumption Analysis Intended for Real Office Space with Energy Recovery Ventilator by Integrating BES and CFD Approaches." *Building and Environment* 52: 57-67.
- Flieger, B., M. Jin, P. Steinhoff, M. Schmidt, D. Müller, and Q. Chen. 2014. "Fluid Flow Simulation for Building Performance Evaluation." In *Proceedings of the BauSIM 2014 IBPSA Germany Conference*, Aachen, Germany.
- Fritzson, P. 1998. "Modelica - A Language for Equation-Based Physical Modeling and High Performance Simulation." *Applied Parallel Computing* 1541: 149-160.
- Gu, L. 2007. "Airflow Network Modeling in EnergyPlus." In *Proceedings of the Building Simulation 2007*.
- Huang, S., and W. Zuo. 2014. "Optimization of the Water-Cooled Chiller Plant System Operation." In *Proceedings of the 2014 ASHRAE/IBPSA-USA Building Simulation Conference*, Atlanta, GA.
- Jin, M., Q. Chen, and W. Zuo. 2013. "Validation of A Fast Fluid Dynamics Program for Simulating Natural Ventilation in Buildings." In *Proceedings of the CLIMA 2013, the 11th REHVA World Congress and the 8th Conference on Indoor Air Quality, Ventilation and Energy Conservation in Buildings*, Prague, Czech, June 16-19.
- Jin, M., W. Zuo, and Q. Chen. 2012a. "Improvement of Fast Fluid Dynamics for Simulating Airflow in Buildings." *Numerical Heat Transfer, Part B Fundamentals* 62 (6): 419-438.
- Jin, M., W. Zuo, and Q. Chen. 2012b. "Validation of Three Dimensional Fast Fluid Dynamics for Indoor Airflow Simulations." In *Proceedings of the the 2nd International Conference on Building Energy and Environment (COBEE2012)*, Boulder, CO.
- Jin, M., W. Zuo, and Q. Chen. 2013. "Simulating Natural Ventilation in and around Buildings by Fast Fluid Dynamics." *Numerical Heat Transfer, Part A: Applications* 64 (4): 273-289.
- Kim, D., W. Zuo, J. E. Braun, and M. Wetter. 2013. "Comparison of Building System Modeling Approaches for Control System Design." In *Proceedings of the the 13th International Conference of the International Building Performance Simulation Association (Building Simulation 2013)*, Chambéry, France.
- Nouidui, T., K. Phalak, W. Zuo, and M. Wetter. 2012. "Validation and Application of the Room Model of the Modelica Buildings Library." In *Proceedings of the the 9th International Modelica Conference*, Munich, Germany, September 3-5.
- Nouidui, T., M. Wetter, and W. Zuo. 2012. "Validation of the Window and the Room Models of the Modelica Buildings Library." In *Proceedings of the the 5th National Conference of International Building Performance Simulation Association -USA (SimBuild2012)*, Madison, WI, August 1-3.
- Tian, W., and W. Zuo. 2013. "Literature Review and Research Needs to Couple Building Energy and Airflow Simulation." In *Proceedings of the the APEC Conference on Low-carbon Towns and Physical Energy Storage*, Changsha, China, May 25-26.

- Wang, L., and Q. Chen. 2007. "Analysis on the Well-Mixing Assumptions Used in Multizone Airflow Network Models." In *Proceedings of the the 10th International Building Performance Simulation Association Conference and Exhibition (Building Simulation 2007)*, Beijing, China.
- Wang, M., and Q. Chen. 2009. "Assessment of Various Turbulence Models for Transitional Flows in an Enclosed Environment (RP-1271)." *HVAC&R Research* 15 (6): 1099-1119.
- Wetter, M. 2011. "Co-Simulation of Building Energy and Control Systems with the Building Controls Virtual Test Bed." *Journal of Building Performance Simulation* 4 (3): 185-203.
- Wetter, M., W. Zuo, and T. Noudui. 2011. "Modeling of Heat Transfer in Rooms in the Modelica "Buildings" Library." In *Proceedings of the the 12th International Conference of the International Building Performance Simulation Association (Building Simulation 2011)*, Sydney, Australia, November 14-16.
- Wetter, M., W. Zuo, T. S. Noudui, and X. Pang. 2014. "Modelica Buildings Library." *Journal of Building Performance Simulation* 7 (4): 253-270.
- Zhai, Z., Q. Chen, P. Haves, and J. Klems. 2002. "On Approaches to Couple Energy Simulation and Computational Fluid Dynamics Programs." *Building and Environment* 37 (8-9): 857-864.
- Zhang, R., K. P. Lam, S.-c. Yao, and Y. Zhang. 2013. "Coupled EnergyPlus and Computational Fluid Dynamics Simulation for Natural Ventilation." *Building and Environment* 68: 100-113.
- Zuo, W., and Q. Chen. 2007. "Validation of Fast Fluid Dynamics for Room Airflow." In *Proceedings of the The 10th International IBPSA Conference (Building Simulation 2007)*, Beijing, China.
- Zuo, W., and Q. Chen. 2009. "Real-Time or Faster-Than-Real-Time Simulation of Airflow in Buildings." *Indoor air* 19 (1): 33-44.
- Zuo, W., and Q. Chen. 2010a. "Fast and Informative Flow Simulations in A Building by Using Fast Fluid Dynamics Model on Graphics Processing Unit." *Building and Environment* 45 (3): 747-757.
- Zuo, W., and Q. Chen. 2010b. "Fast Simulation of Smoke Transport in Buildings." In *Proceedings of the the 41st International HVAC&R congress*, Beograd, Serbian, December 1-3.
- Zuo, W., and Q. Chen. 2010c. "Simulations of Air Distribution in Buildings by FFD on GPU." *HVAC&R Research* 16 (6): 783-796.
- Zuo, W., and M. Wetter. 2011. "Advanced Simulations of Building Energy and Control Systems with An Example of Chilled Water Plant Modeling." In *Proceedings of the The 8th International Forum and Workshop on Combined Heat, Air, Moisture and Pollutant Simulations (CHAMPS 2011)*, Nanjing, China.
- Zuo, W., M. Wetter, D. Li, M. Jin, W. Tian, and Q. Chen. 2014. "Coupled Simulation of Indoor Environment, HVAC and Control System by Using Fast Fluid Dynamics and Modelica." In *Proceedings of the 2014 ASHRAE/IBPSA-USA Building Simulation Conference*, Atlanta, GA, Sep. 10-12.