

Kent Academic Repository

Full text document (pdf)

Citation for published version

Sanz-Izquierdo, Benito and Huang, F. and Batchelor, John C. (2006) Covert Dual-Band Wearable Button Antenna. *Electronics Letters*, 42 (12). pp. 668-670.

DOI

<https://doi.org/10.1049/el:20060482>

Link to record in KAR

<http://kar.kent.ac.uk/425/>

Document Version

Author's Accepted Manuscript

Copyright & reuse

Content in the Kent Academic Repository is made available for research purposes. Unless otherwise stated all content is protected by copyright and in the absence of an open licence (eg Creative Commons), permissions for further reuse of content should be sought from the publisher, author or other copyright holder.

Versions of research

The version in the Kent Academic Repository may differ from the final published version.

Users are advised to check <http://kar.kent.ac.uk> for the status of the paper. **Users should always cite the published version of record.**

Enquiries

For any further enquiries regarding the licence status of this document, please contact:

researchsupport@kent.ac.uk

If you believe this document infringes copyright then please contact the KAR admin team with the take-down information provided at <http://kar.kent.ac.uk/contact.html>

COVERT DUAL BAND WEARABLE BUTTON ANTENNA

B. Sanz-Izquierdo, F. Huang and J.C. Batchelor

This paper is a postprint of a paper submitted to and accepted for publication in IET Microwaves, Antennas and Propagation and is subject to Institution of Engineering and Technology Copyright. The copy of record is available at IET Digital Library

COVERT DUAL BAND WEARABLE BUTTON ANTENNA

B. Sanz-Izquierdo, F. Huang and J.C. Batchelor

INDEXING TERMS

Wearable Antennas, Dual band antennas, WLAN, Pervasive computing

ABSTRACT

This letter introduces a novel dual band antenna for wearable WLAN computing applications. This antenna comprises 3 discs and a coaxial post. Its appearance is of a standard metal button of the type used in denim jeans. The antenna is easily disguised and is less sensitive to clothing than printed patches which use the textile fabric as a substrate or superstrate. The antenna requires no external matching circuitry and operates at 2400MHz and 5200MHz. The radiation patterns are omni-directional around the central post of the antenna.

INTRODUCTION

The trend for mobile systems is to evolve into pervasive computing networks, communicating directly with other worn devices and to access points off the body. Microstrip antennas mounted on textile substrates have been proposed to serve these mobile distributed systems [1 and 2] and PIFAs have been assessed for performance when used in close proximity to the human body, [3]. Additionally, a study has been carried out to assess propagation around a user's body and identify suitable antenna sites, [4]. This study used standard monopole and coil antennas. This letter introduces a novel structure for a wearable antenna that has the appearance of a metal button for fastening clothing. The structure of the button antenna is shown in Fig.1.

The choice of a button shape offers certain benefits. Firstly, clothing fabric does not fill a resonant cavity of the antenna as it does with patch antennas. This alleviates uncertainties in characterising the substrate due to poor permittivity quantification and stability. For instance moisture uptake will vary markedly with time and the compression and flexing of the material will also affect the

antenna performance. Secondly, the small area of the button means that it does not need to be conformal to the fabric surface and is therefore immune to variations due to flexing. Thirdly, a large ground plane is not necessary and finally, the structure is simple to integrate with clothing using ordinary sewing. It may even be possible to fit retrospectively.

DESIGN AND MEASUREMENT

The principle button antenna dimensions are illustrated in Figs.1 and 2 and tabulated in Table I. The overall size is virtually identical to that of a standard trouser button. It has a 50Ω input impedance at both bands and is side fed by a microstrip line connected to the bottom disc. A flexible plastic layer forms a dielectric layer between the base disc and the ground plane. Vecro® was used for the dielectric layer due to its flexibility and potential good resistance to compression. It is possible to rear feed the antenna with a coaxial line should it be preferred to side feeding.

The 2 bands of operation can be seen in the measured and simulated S11 curves are given in Fig.3. The matched frequencies cover the WLAN/Bluetooth and HiperLAN/2 systems. The measured -10dB S11 bandwidths at 2.4GHz and 5.2GHz were 6% and 27% respectively. Results obtained from CST Microwave Studio simulations are summarised in Table II. It was demonstrated that the lower band is tuned by the diameter of the upper disc (Dd) and the bandwidth is influenced by the gap (G) between the upper discs. Both bands were affected by the antenna height (Th) affected both bands but mainly widened the upper bandwidth.

Examination of the current distributions presented in Fig.4a and b for the lower and upper modes respectively indicates that it is currents in the post between the upper plates that contribute most to radiation at the lower band. At the upper band it is the currents that flow up the outside of the centre post that radiate. These currents are excited by fields beneath the base disc.

The measured x-y plane radiation patterns for the button antenna are shown in Fig.5 where good omni-directionality is observed. The z-axis is normal to the user's body, meaning some radiation will be tangential to the user's body. It is shown in [4] that electromagnetic body modes are

influential in guiding signals around the user. Therefore connection may be made to other worn devices and also to elevated external access points.

Preliminary measurements taken with the antenna in situ in the centre of the chest of a human body show an expected frequency reduction in the lower band of no more than 40MHz and no significant change for the higher band. Some nulls in the radiation pattern were observed to be filled due proximity of the human body.

CONCLUSIONS

A novel dual-band antenna has been presented with the overall dimensions and appearance of a standard jeans button. The button antenna is resonant at both the 2.4GHz and 5.2-5.5GHz WLAN bands. Capacitance between the upper plates largely determines the lower band frequencies while the lower disc size controls the upper band. The upper bandwidth is strongly determined by capacitance between the upper and lower discs. A simulation study has indicated that the modes may be tuned independently by varying the diameter of the top disc and the gap between the two discs. Good omni-directional patterns are measured and the gain is predicted to be around 2.4dB.

ACKNOWLEDGEMENT

The authors would like to thank Terry Rockhill and Clive Birch for helping in the fabrication and Nigel Simpson for help with the measurement of the antennas.

AUTHORS' AFFILIATION:

Department of Electronics,
The University of Kent
Canterbury, Kent, CT2 7NT, UK.
Tel: +44 1227 827004, Fax: +44 1227 456084

Email: j.c.batchelor@kent.ac.uk

REFERENCES

- [1] Salonen, P., Kim, J., and Rahmat-Samii, Y.: “Dual-Band E-Shaped Patch Wearable Textile Antenna”, IEEE Proc. AP-S, Washington DC, 2005.
- [2] Ouyang, Y., Karayianni, E. and Chappell, W.J.: “Effect of Fabric Patterns on Electrotexile Patch Antennas”, IEEE Proc. AP-S, Washington DC, 2005.
- [3] Terence, S.P. See and Zhi Ning Chen: “Effects of Human Body on Performance of Wearable PIFAs and RF Transmission”, IEEE Proc. AP-S, Washington DC, 2005.
- [4] Kamarudin, M.R., Nechayev, Y.I., and Hall, P.S.: “Performance of Antennas in the On-Body Environment”, IEEE Int. Workshop on Antenna Technology, IWAT, pp.17-20, Singapore, March 2005.

List of Tables:

Table I. Principle antenna dimensions

Table II. Frequency dependence on principle antenna dimensions.

List of Figures:

Figure 1. Button Antenna Geometry.

Figure 2. Antenna Elevation with principle dimensions.

Figure 3. Measured and computed S11 curves for dual band button antenna.

Figure 4. Surface currents at, (a) 2450 MHz and (b) 5250 MHz

Figure 5. Measured x-y plane radiation patterns of Button Antenna. (a) 2.4GHz; (b) 5.2GHz; (c) 5.5GHz.

— Co-polarisation
— Cross polarisation

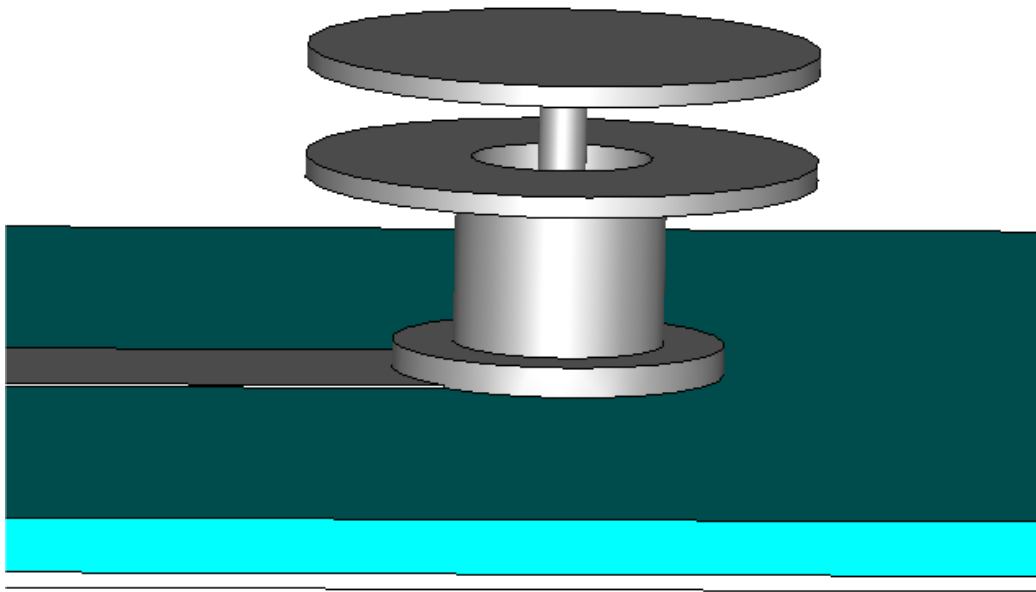

Figure 1. Button Antenna Geometry

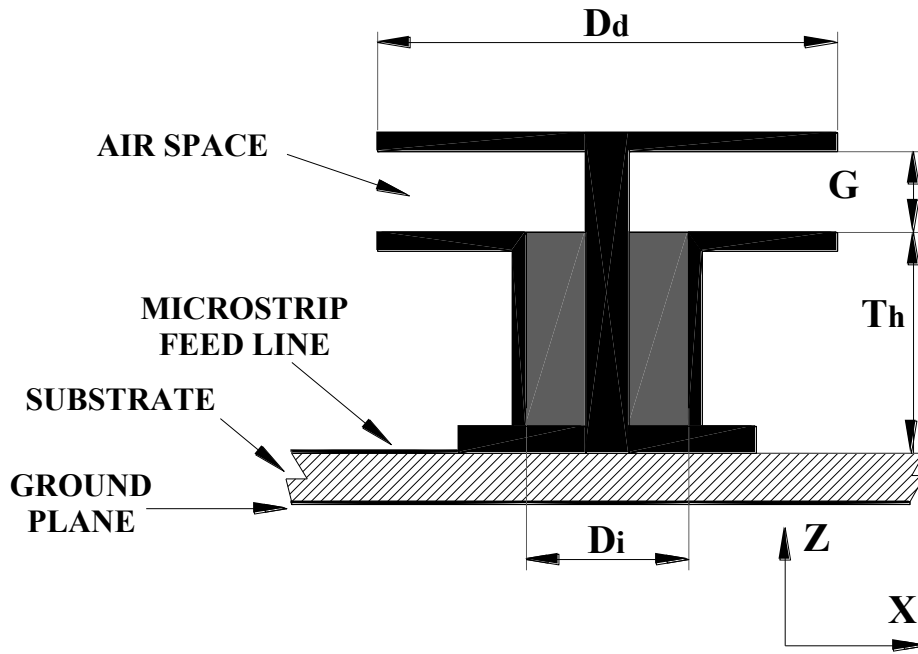

Figure 2. Antenna Elevation with principle dimensions

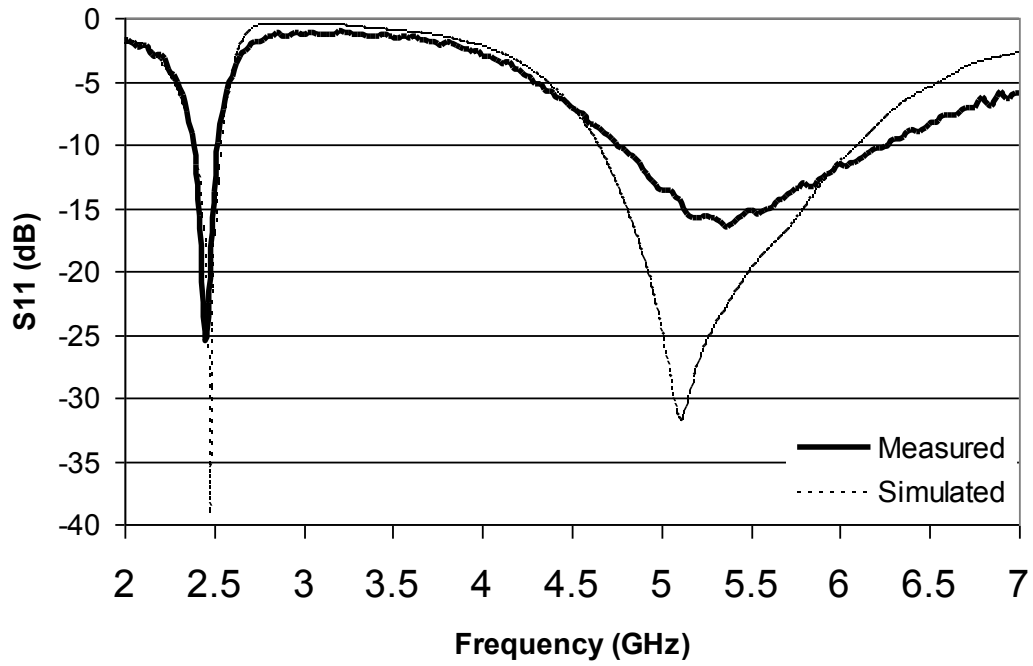

Figure 3. Measured and computed S_{11} curves for dual band button antenna.

Min: 0 / Max: 10

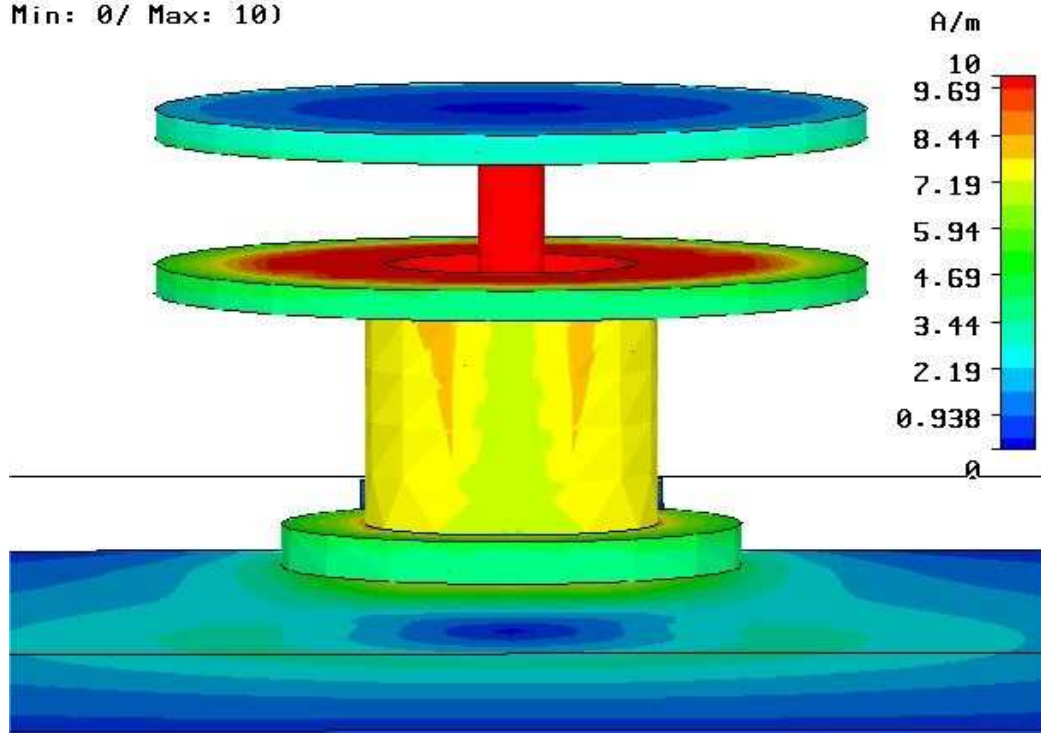

Figure 4a. Surface currents at 2450 MHz

Min: 0 / Max: 10)

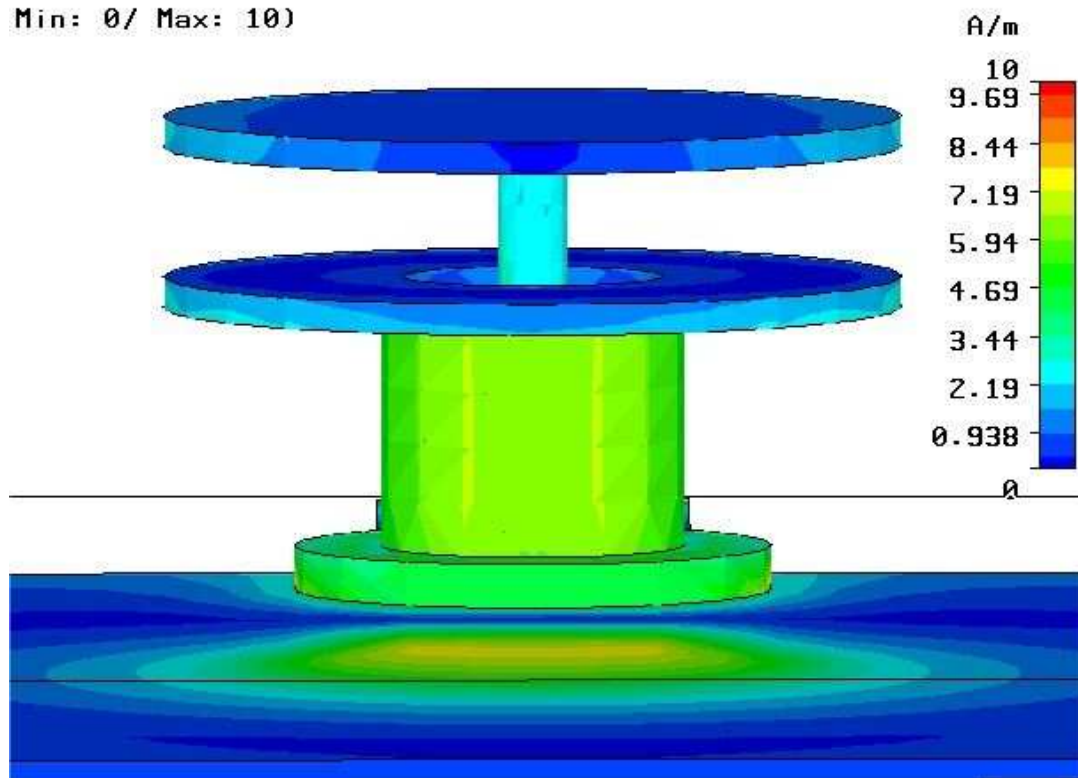

Figure 4b. Surface currents at 5250 MHz

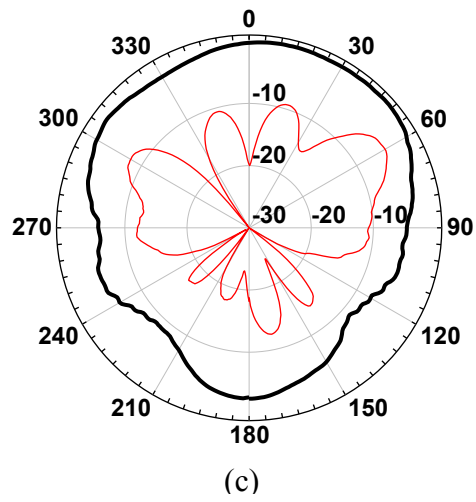
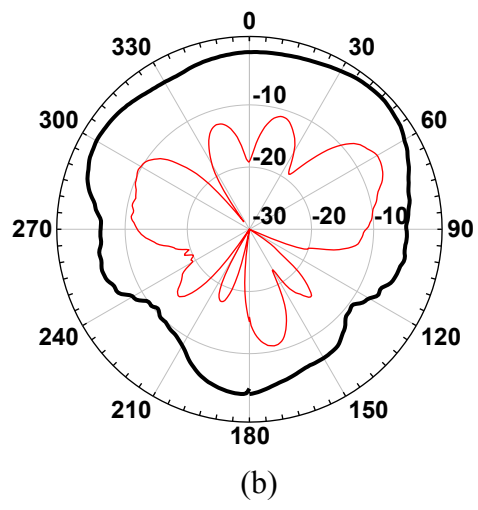
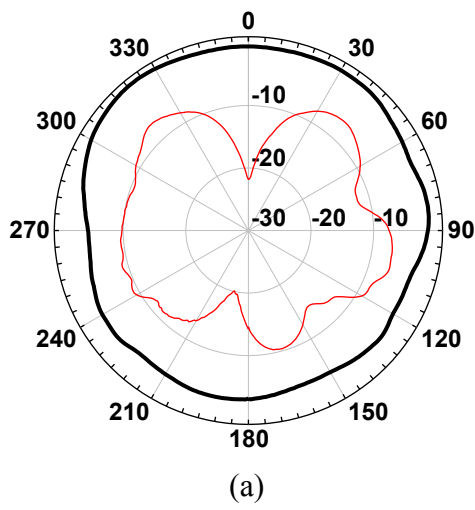

Figure 5. Measured x-y plane radiation patterns of Button Antenna. (a) 2.4GHz; (b) 5.2GHz; (c) 5.5GHz.

Co-polarisation
 Cross polarisation

Table I. Principle antenna dimensions

Parameter	Size (mm)
Top disc diameter, Dd	17
Air space between plates, G	3
Height of main cylinder, Th	8
Diameter of main cylinder, Di	6

Table II. Frequency dependence on principle antenna dimensions.

Dimension	Change in dimension (%)	Lower band Frequency deviation (%)	Change in lower bandwidth (%)	Upper band frequency deviation (%)	Change in upper bandwidth (%)
<i>Dd</i>	+13	-7	+13	0	+3
<i>G</i>	+300	+16	+200	+2	-10
<i>Th</i>	+36	-10	+6	-1	+110