



LUND UNIVERSITY

Crank Angle Resolved HC Detection Using LIF in the Exhausts of Small Two-Stroke Engines Running at High Engine Speed

Andersson, Öivind; Juhlin, Greger; Ekenberg, Martin; Johansson, Bengt; Aldén, Marcus

Published in:
SAE Transactions, Journal of Engines

1996

[Link to publication](#)

Citation for published version (APA):

Andersson, Ö., Juhlin, G., Ekenberg, M., Johansson, B., & Aldén, M. (1996). Crank Angle Resolved HC Detection Using LIF in the Exhausts of Small Two-Stroke Engines Running at High Engine Speed. *SAE Transactions, Journal of Engines*, 105(961927). <http://www.sae.org/technical/papers/961927>

Total number of authors:
5

General rights

Unless other specific re-use rights are stated the following general rights apply:
Copyright and moral rights for the publications made accessible in the public portal are retained by the authors and/or other copyright owners and it is a condition of accessing publications that users recognise and abide by the legal requirements associated with these rights.

- Users may download and print one copy of any publication from the public portal for the purpose of private study or research.
- You may not further distribute the material or use it for any profit-making activity or commercial gain
- You may freely distribute the URL identifying the publication in the public portal

Read more about Creative commons licenses: <https://creativecommons.org/licenses/>

Take down policy

If you believe that this document breaches copyright please contact us providing details, and we will remove access to the work immediately and investigate your claim.

LUND UNIVERSITY

PO Box 117
221 00 Lund
+46 46-222 00 00

Crank Angle Resolved HC-Detection Using LIF in the Exhausts of Small Two-Stroke Engines Running at High Engine Speed

**Öivind Andersson, Greger Juhlin, Martin Ekenberg,
Bengt Johansson, and Marcus Aldén**
Lund Institute of Technology

**Reprinted from: Diagnostics and Modeling in SI Engines
(SP-1212)**

The appearance of the ISSN code at the bottom of this page indicates SAE's consent that copies of the paper may be made for personal or internal use of specific clients. This consent is given on the condition however, that the copier pay a \$7.00 per article copy fee through the Copyright Clearance Center, Inc. Operations Center, 222 Rosewood Drive, Danvers, MA 01923 for copying beyond that permitted by Sections 107 or 108 of the U.S. Copyright Law. This consent does not extend to other kinds of copying such as copying for general distribution, for advertising or promotional purposes, for creating new collective works, or for resale.

SAE routinely stocks printed papers for a period of three years following date of publication. Direct your orders to SAE Customer Sales and Satisfaction Department.

Quantity reprint rates can be obtained from the Customer Sales and Satisfaction Department.

To request permission to reprint a technical paper or permission to use copyrighted SAE publications in other works, contact the SAE Publications Group.



GLOBAL MOBILITY DATABASE

All SAE papers, standards, and selected books are abstracted and indexed in the Global Mobility Database.

No part of this publication may be reproduced in any form, in an electronic retrieval system or otherwise, without the prior written permission of the publisher.

ISSN 0148-7191

Copyright 1996 Society of Automotive Engineers, Inc.

Positions and opinions advanced in this paper are those of the author(s) and not necessarily those of SAE. The author is solely responsible for the content of the paper. A process is available by which discussions will be printed with the paper if it is published in SAE Transactions. For permission to publish this paper in full or in part, contact the SAE Publications Group.

Persons wishing to submit papers to be considered for presentation or publication through SAE should send the manuscript or a 300 word abstract of a proposed manuscript to: Secretary, Engineering Meetings Board, SAE.

Crank Angle Resolved HC-Detection Using LIF in the Exhausts of Small Two-Stroke Engines Running at High Engine Speed

Öivind Andersson, Greger Juhlin, Martin Ekenberg,
Bengt Johansson, and Marcus Aldén

Lund Institute of Technology

Copyright 1996 Society of Automotive Engineers, Inc.

ABSTRACT

In order to separate the HC-emissions from two-stroke engines into short-circuit losses and emissions due to incomplete combustion, Laser Induced Fluorescence (LIF) measurements were performed on the exhaust gases just outside the exhaust ports of two engines of different designs.

The difference between the two engines was the design of the transfer channels. One engine had "finger" transfer channels and one had "cup handle" transfer channels. Apart from that they were similar. The engine with "finger" transfer channels was earlier known to give more short-circuiting losses than the other engine, and that behavior was confirmed by these measurements.

Generally, the results show that the emission of hydrocarbons has two peaks, one just after exhaust port opening and one late in the scavenging phase.

The spectral information shows differences between the two peaks and it can be concluded that the latter peak is due to short-circuiting and the earlier due to incomplete combustion.

The flow outside the exhaust port was measured with Laser Doppler Velocimetry (LDV). These measurements confirm the occurrence of two emission peaks.

INTRODUCTION

The two-stroke spark-ignition engine is a very simple and light engine concept which finds its greatest use as a portable power source where these advantages are important. However, one inherent weakness is that fresh fuel-air mixture short-circuits the cylinder directly to the exhaust system during the scavenging process. This constitutes a significant fuel consumption penalty as well as excessive emissions of unburned hydrocarbons (HC). HC-emissions from carbureted two-stroke engines are about five times as

high as those of equivalent four-stroke engines due to scavenging losses of fresh fuel-air mixture [1].

Due to environmental and fuel-economy considerations it is desirable to minimize the scavenging losses of fuel. The transfer channel geometry is of great importance as to achieve the longest possible path for the fuel to travel in the cylinder before it reaches the exhaust port. Proper flow patterns for the fresh charge are extremely important for good scavenging and charging of the cylinder [1]. To detect when during the scavenging process HC is emitted, some form of fast detector is necessary. The conventional method for cycle-resolved measurements of HC emissions from spark ignition engines is using a fast-response flame ionization detector (Fast-FID). This detector is fast enough to resolve the engine cycle at low engine speed but has a response time of more than 4 ms [2]. This response time corresponds to 34 crank angle degrees (CAD) at 9000 rpm. As the working speed of handheld two-stroke engines is very high (9000-20000 rpm) this method can hardly be used to accurately measure what happens during different phases of the engine cycle.

Investigations of engine behavior have been carried out with increasing success during the last decade using different laser techniques. Some of the advantages of laser measuring techniques are their ability to offer high spatial and temporal resolution, in combination with a favorable non-intrusiveness. The Laser-Induced Fluorescence (LIF) technique e.g. offers a great potential for measurements of species concentrations without disturbing the gas flow as would a probe.

LIF is based on absorption of laser radiation by a species followed by spontaneous emission of light. The emitted spectrum is characteristic for the fluorescing molecule. If short laser pulses are used it is possible to make instantaneous concentration measurements of emissions in the exhaust gases during the engine working cycle [3].

The aim of the present experiment was to investigate the composition of exhaust gases from small, carbureted two-stroke engines. Quantitative measurements were not attempted. To get quantitative results a thorough calibration procedure must be made, taking quenching and temperature effects into account. The scavenging losses were to be separated from other emissions by means of crank angle resolved LIF measurements just outside the exhaust port.

Two measuring strategies were followed. To visualize the overall abundance of HC emissions during different phases of the engine cycle, imaging measurements were carried out outside the exhaust port at different crank angle degrees (CAD). The fluorescence signal could thus be evaluated and resolved over the engine cycle. Spectral measurements were also carried out, allowing crank angle resolved analysis of the composition of the emissions.

EXPERIMENTAL APPARATUS

ENGINE - The engine was a 60 cc carbureted two-stroke engine run with two different cylinders. The difference between the cylinders was the design of the transfer channels. One had cup-handle transfer channels, the other one had channels of finger-type, see figure 1. The engine was run with wide open throttle at 9000 rpm. To enable optical access, the silencer was removed. This has an impact on the in-cylinder gas dynamics. The engine type studied does, however, not use a tuned exhaust system. According to the engine manufacturer this reduces the effect of exhaust system on gas exchange.

LIF SETUP - The setup was built up around the engine which had a crank angle encoder attached to the crank shaft. A pulsed laser and a CCD detection system was triggered at the desired crank-angle by means of the encoder and a pulse counter. The laser beam thus intersected the flow of emissions just outside the exhaust port and the fluorescence signal hereby achieved was collected by the CCD system.

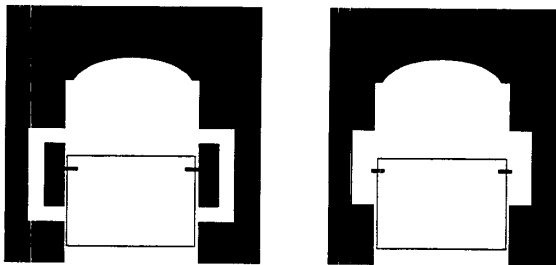

Figure 1: The design of cup-handle transfer channels (to the left) and finger transfer channels (to the right).

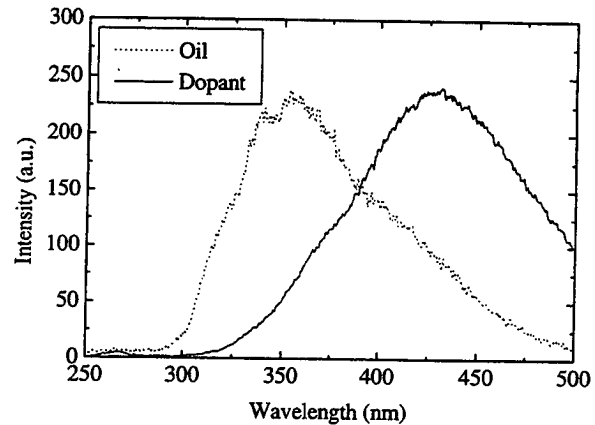

Figure 2: The feature to the right is the fluorescence from 3-pentanone. The left feature is oil fluorescence. The features overlap, but can be resolved.

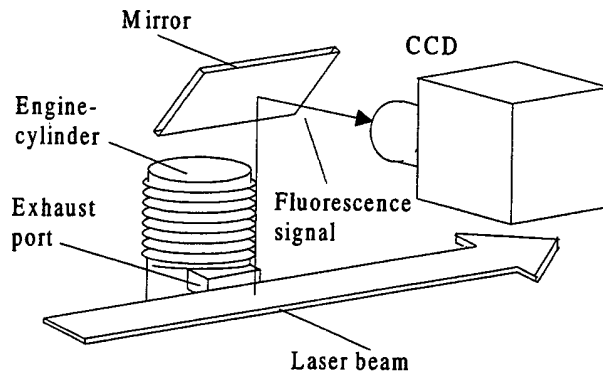

Figure 3a: Experimental setup for imaging measurements. The horizontal laser sheet was focused with a cylindrical lens.

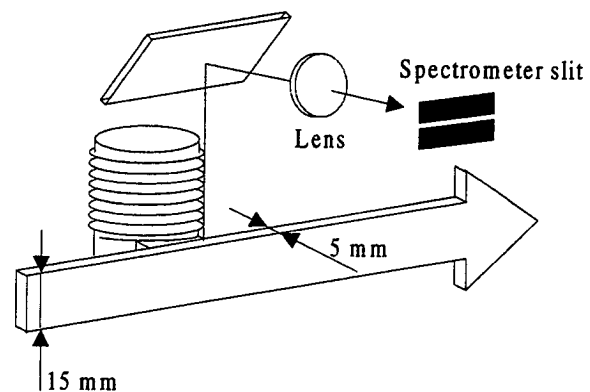

Figure 3b: Experimental setup for spectral measurements. The vertical laser sheet was unfocused.

Laser - A tunable KrF excimer laser was used (Lambda Physik EMG 150 MSC) with a maximum pulse energy of 250 mJ at 248 nm and a pulse duration of 17 ns. The emitted beam had a rectangular cross section (5 mm × 15 mm). During the imaging measurements the thickness of the laser sheet was decreased by means of a cylindrical quartz lens from 5 mm to 250 μm, as to increase the signal intensity and to decrease the depth of the imaged plane (i.e. increasing the spatial resolution).

Detector - The fluorescence signal was detected with an image intensified CCD camera (ICCD 576S/RB-T from Princeton Instruments). It consists of an image intensifier and a CCD chip. By gating the photo cathode voltage of the image intensifier, temporal resolution down to 5 ns is feasible.

FUEL - To simplify the data analysis it was desirable to minimize the number of species occurring in the exhaust gases. Since gasoline contains a variety of hydrocarbons, a simpler fuel containing fewer molecular species had to be used. Isooctane has a number of features in common with gasoline and was decided to be a suitable replacement.

Dopant - To be able to monitor the emission of unburned fuel a fluorescing dopant must be added to the isooctane, which does not fluoresce in itself [4]. Important features of the dopant are vaporization characteristics [5] and solubility in the fuel [5, 6]. Examples of dopants that have been used are acetaldehyde [7, 8], acetone [8] and biacetyl [9, 10]. The vaporization characteristics are described by the dependence of the vapor pressure on temperature. Both acetaldehyde and acetone have excessive differences in vaporization characteristics compared with isooctane [11]. Also biacetyl differs from isooctane in this respect [4]. There is, however, an almost perfect correspondence between the isooctane and 3-pentanone vaporization characteristics [4]. An added amount of 3-pentanone will thus be likely to follow the isooctane during the scavenging process. During the last years there have been LIF applications using 3-pentanone as a dopant [4, 12, 13]. The absorption spectrum of 3-pentanone is ranging from 220 to 320 nm with a maximum at 280 nm [14]. As can be seen in figure 2, 3-pentanone (diethyl ketone) has an emission spectrum between 330 and 600 nm, with a peak at 430 nm.

Lubrication oil - Due to the simple construction of this engine-type, engine lubricant must be added to the fuel. After some investigations an oil was found that fluoresces between 300 nm and 500 nm with a peak at 350 nm. Using this oil and 3-pentanone in principle allows separate detection of the emission of oil and fuel.

IMAGING MEASUREMENTS

Imaging measurements were performed by placing the laser sheet horizontally just outside the engine's exhaust port, see figure 3a. The fluorescence signal emitted as the exhaust gases passed through the sheet was mirrored and imaged from above with a commercial Nikon camera lens (70 - 210 mm zoom). If the imaging system had been placed in front of the port, the signal would have had to be viewed through the exhaust gases. Imaging from above avoids this and thus minimizes scattering and absorption of the signal.

The images were achieved by triggering the laser at a certain crank angle position and accumulating the LIF signal from 100 laser shots. This minimizes the effect of shot-to-shot fluctuations in laser power and fluctuations in the engine behavior.

Apart from HC the exhaust gases contain a number of species of which CO₂ and H₂O are most abundant. CO₂ does not absorb at 248 nm and thus gives no contribution to the fluorescence [3]. Water fluorescence can, however, be induced via a two-photon transition at 124 nm (1/2 × 248 nm) [15]. This process is weak and a possible contribution from water will be negligible. N₂, O₂, and low levels of CO and NO_x are also present, but neither of these species contribute to the fluorescence signal when using this laser [3]. NO can potentially interfere, but its absorption lies near the edge of the tuning range of the laser and is easily avoided. As it turns out, only the HC components of the emissions will give important contributions to the fluorescence signal.

DATA PROCESSING - Evaluation of the imaging measurements was performed by subtracting a background image from each image in the measuring series. The background image was acquired without the engine running.

RESULTS - Four examples of two-dimensional LIF images are shown in figures 4a-4d. The bottom of each image corresponds to the location of the exhaust port. The two images taken before bottom dead center (BDC) shows that the cup handle geometry gives a higher intensity peak at blowdown and has more fuel concentrated in the center of the port. After BDC the opposite trend is shown. Here the finger type geometry has much higher intensity and a much more uneven distribution of signal over the image. Images were acquired at several different crank angles. The average signal intensity within the image, confined by the edges of the laser sheet and the exhaust port, was calculated for all images acquired at various crank angle degrees. This area was 12 by 25 mm. When plotting the hereby achieved average fluorescence signal as a function of crank angle, a characteristic curve resulted.

A striking similarity between the two cylinder geometries investigated was the of two more or less pronounced peaks in signal intensity.

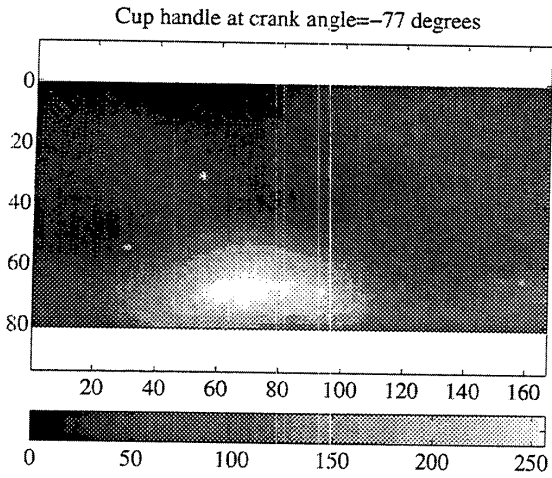

Figure 4a: Image of LIF signal intensity for the cup handle geometry during blowdown.

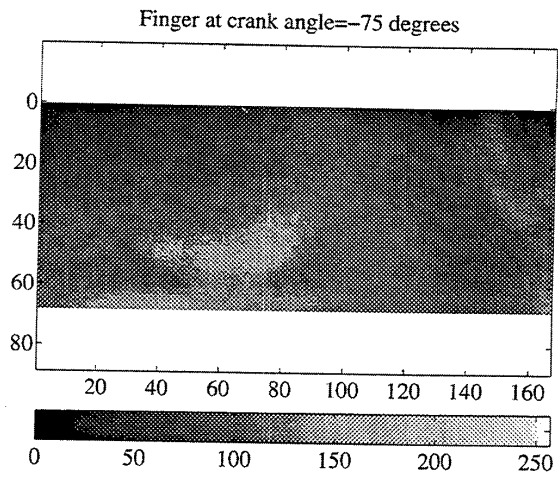

Figure 4b: Image of LIF signal intensity for the finger geometry during blowdown.

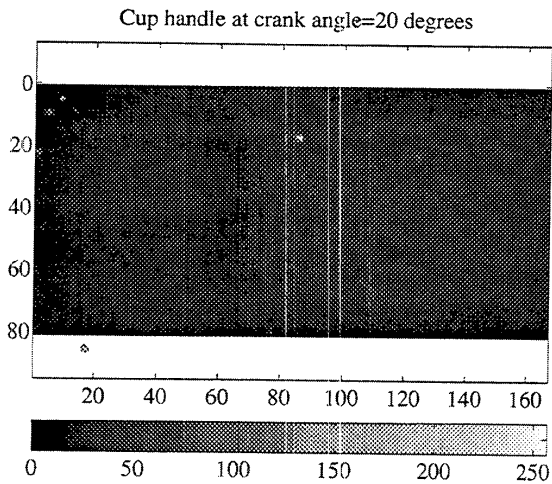

Figure 4c: Image of LIF signal intensity for the cup handle geometry in the scavenging process.

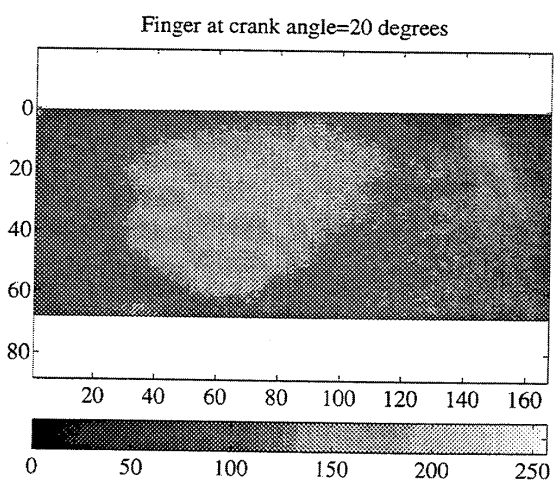

Figure 4d: Image of LIF signal intensity for the finger geometry later in the scavenging process.

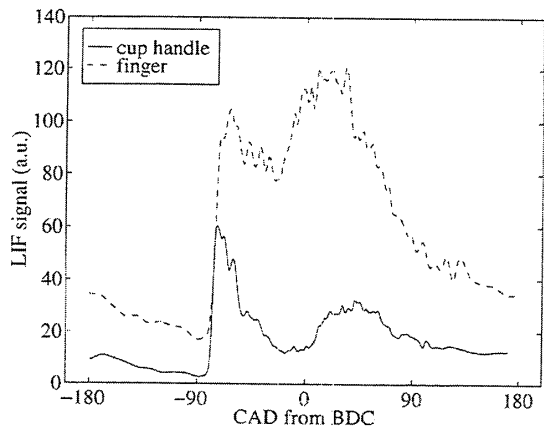

Figure 5: Mean LIF intensity in the evaluation area outside exhaust port.

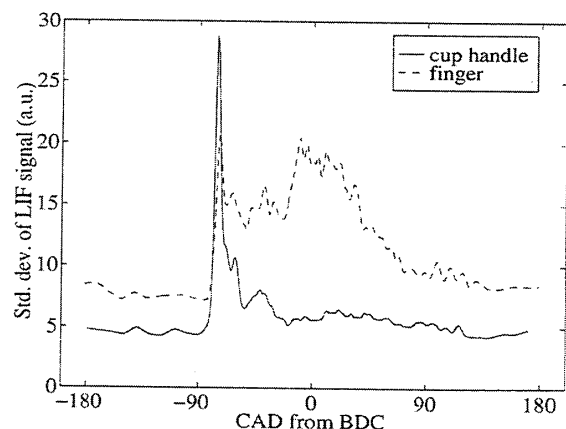

Figure 6: Standard deviation of intensity within the images

The first peak occurred during the blowdown phase directly after the opening of the exhaust port, whereas the position of the second peak varied between the cylinder geometries. The first peak was believed to mainly contain burned gases and the second to consist of fresh fuel-air mixture. This interpretation was later confirmed by the spectral measurements. In figure 5 these typical curves are shown, where the solid curve is the result of measurements on the cup-handle type cylinder and the dashed curve is the result of the simpler finger geometry. Note that there is a delay of more than 10 CAD between the instant where the emissions leave the cylinder and the point where they reach the measurement region. This delay is due to the finite velocity of the exhaust gases, see figure 14.

The absence of a sharp separation between the peaks for the finger-type engine is interpreted as an earlier beginning of the scavenging losses in comparison to the cup-handle engine, for which the second peak starts after the bottom dead center (BDC). This indicates that the cup-handle geometry is more efficient in retaining the fresh charge. If it is assumed that the course of combustion is the same in both cylinder geometries, the combustion products and emission temperature should be the same. As an effect, the first peak should be of equal height for both engines in figure 5. As can be observed this is not the case. The difference in height can be explained by variations in laser power between the measurements and slight changes in the alignment of the experimental setup. It can, however, be concluded that the height of the second peak not only is higher in relation to the first peak for the finger-type cylinder (dashed curve in figure 5); it is also higher than the second peak for the cup-handle geometry (solid curve). Based on our assumptions it can be concluded that the absolute level of emissions of short-circuiting fuel is higher in the finger geometry than in the cup-handle geometry. This is also known from other types of measurements on these engines.

Figure 6 shows the standard deviation of the LIF signal within individual images as a function of crank angle position. The standard deviation of all pixels within each image gives a measure of how much the signal level varies with respect to the mean intensity. It thus tells us how homogeneous the HC-distribution is across the imaged region¹. It is observed that the standard deviation is high during the blowdown phase for both engines, due to the exhaust gases being emitted in the form of a more or less well defined jet. During the scavenging phase the finger geometry is more inhomogeneous than the cup-handle geometry. This is due to the presence of particles (droplets) which has also been observed in LDV measurements on these engines, see figure 15.

¹ The standard deviation used here should not be mistaken for the cycle to cycle variation of mean LIF intensity.

SPECTRAL MEASUREMENTS

As can be seen in figure 3b, the laser sheet was placed vertically outside the exhaust port during the spectral measurements. The fluorescence was mirrored in the same manner as during the imaging measurements. The slit of the spectrometer was placed parallel to the beam and the sheet was imaged on the slit by means of a 200 mm spherical, fused silica lens. Emission from the entire height of the sheet was thus imaged onto the spectrometer slit. This increased the signal level. Just as during the imaging measurements, the LIF signal from 100 laser shots were accumulated.

SIGNAL DETECTED - When the laser light passes through a gas it can be elastically scattered by molecules (Rayleigh scattering) or particles (Mie scattering). Due to the strong nature of these scattering processes at short wavelengths [2], a peak at the laser wavelength in some cases dominates the spectrum and limits the sensitivity of the detection system if it is not spectrally filtered. Therefore a 10 mm thick liquid butyl acetate filter was placed in front of the detection system during all measurements. Butyl acetate has a steep cutoff between 250 nm and 260 nm [16], thus suppressing the laser wavelength (248 nm) by two orders of magnitude.

The oil added to isooctane for lubrication was found to fluoresces between 300 nm and 500 nm with a peak at 350 nm. This is shifted from the wavelength interval in which 3-pentanone fluoresces. Hence a spectral separation of oil and short-circuiting fuel can be obtained. A separation between fresh fuel and partially burned fuel originating from the combustion can be found due to the very reactive nature of 3-pentanone. Fuel/air-mixture that has taken part in the high-pressure cycle will not contain any significant amount of 3-pentanone afterwards.

During the spectral measurements spectra were collected at various crank angles. A background spectrum was acquired without the engine running and subtracted. The resulting spectra had a wide peak around 350 nm and superposed on this a wide distribution around 430 nm. The feature at 350 nm consists to a great extent of oil and probably also of partially burned hydrocarbons [1]. The distribution around 430 nm originates from the added dopant, 3-pentanone, and indicates the occurrence of unburned fuel.

As predicted, spectra recorded at different crank angles reveal differences in the chemical composition of the emissions. Unfortunately the oil- and 3-pentanone features could not be fully resolved.

Spectra from the emission peak around 70 CAD before BDC are shown in figure 7a and spectra from the peak occurring around 70 CAD after BDC are shown in figure 7b. The data comes from the cup-handle type cylinder, running on two different fuel mixtures. Isooctane with a 5% (vol) concentration of 3-pentanone was used during one measuring series, a 2% content was used

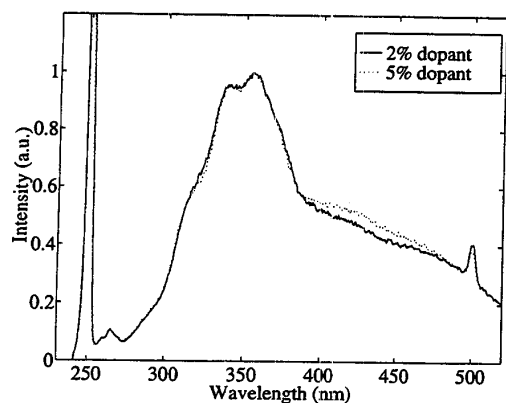

Figure 7a: Spectra recorded at 70 CAD before BDC with cup-handle geometry

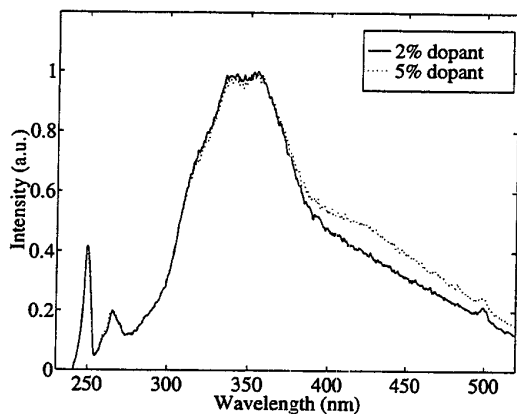

Figure 7b: Spectra recorded at 70 CAD after BDC (peak II in figure 5).

during the other. The upper (dotted) curves in figure 7a and 7b correspond to the higher concentration of 3-pentanone; whereas the lower (solid) curves correspond to the lower concentration. Diagram 7a shows almost no difference between the spectra. Diagram 7b, however, has a greater intensity around 430 nm in the case of higher 3-pentanone content. It can clearly be seen that the second emission peak contains a considerable amount of unburned fuel, whereas the first peak does not. Note that the peak at 248 nm is higher in figure 7a than in figure 7b. This is due to strong Mie-scattering of the laser wavelength from particles/droplets present in the exhaust gases. These particles can actually be seen in figure 4a. This conclusion is also confirmed by the LDV measurements, see figure 15. RESULTS - The spectra from different crank angle positions were separated in to three different regimes, called region A, B and C. Region A is ranging from 240 to 265 nm, and contains the Mie-scattering signal. Region B is the wavelength interval from 265-390 nm, i.e. mostly covering the LIF signal from oil and partially burned fuel. The last region, C, covers the signal from 3-pentanone and

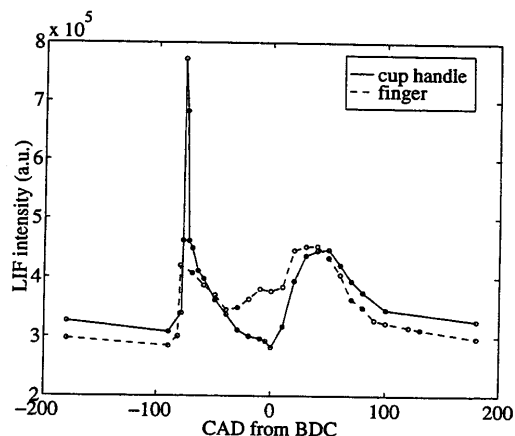

Figure 8a: LIF intensity over the entire wavelength interval measured. Two per cent 3-pentanone was used.

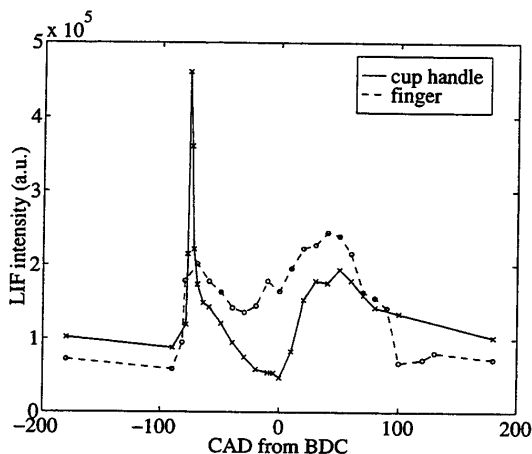

Figure 8b: LIF intensity over the entire wavelength interval measured. Five per cent 3-pentanone was used

ranges from 390 to 525 nm. Figure 8 to 11 shows the intensity within the different regions as well as the total signal intensity for the two cylinders.

It can be seen that the Mie-scattering trend, region A, is rather similar for the two cylinders, except for the first blowdown peak found for the cup handle cylinder. The percentage of 3-pentanone does not change the trends significantly. Region B also reveals rather similar trends for the two geometries. Two distinct peaks can be observed. The first originates from the blowdown phase. The reasons for the second peak is less clear. It can be signal from fresh charge oil in combination with partially burned residuals.

Region C shows a significant difference between the two cylinders. Here the cup handle type also has two distinct peaks whereas the finger type has a continuous high level during the gas exchange process. The first peak for the cup handle geometry is somewhat unexpected.

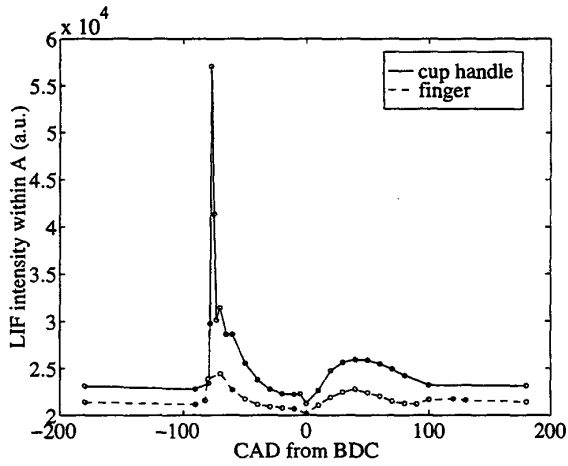

Figure 9a: Signal level from Mie scattering. Two percent 3-pentanone added to fuel..

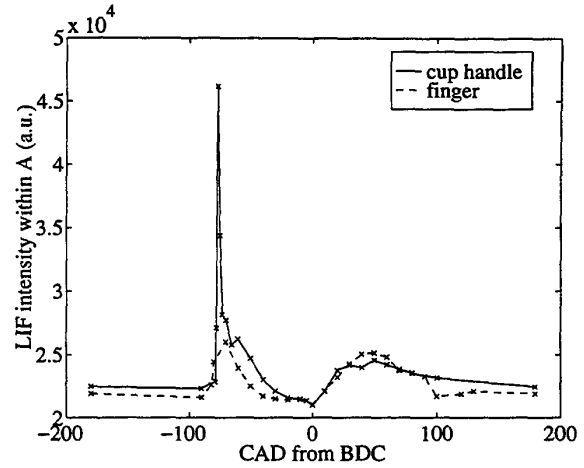

Figure 9b: Signal level from Mie scattering. Five percent 3-pentanone added to fuel..

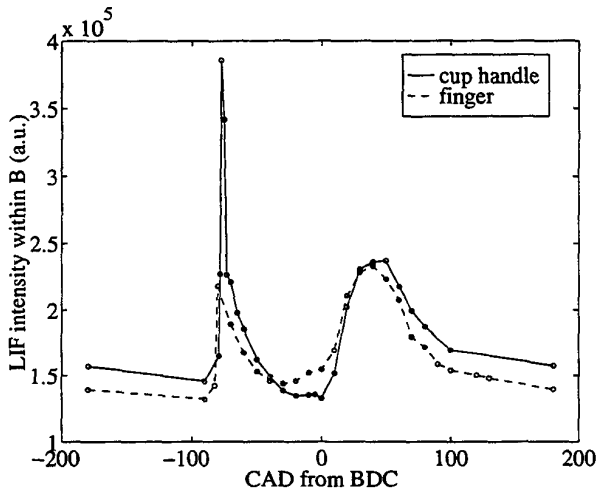

Figure 10a: Signal from mostly oil and partially burned fuel. Two percent 3-pentanone added to fuel..

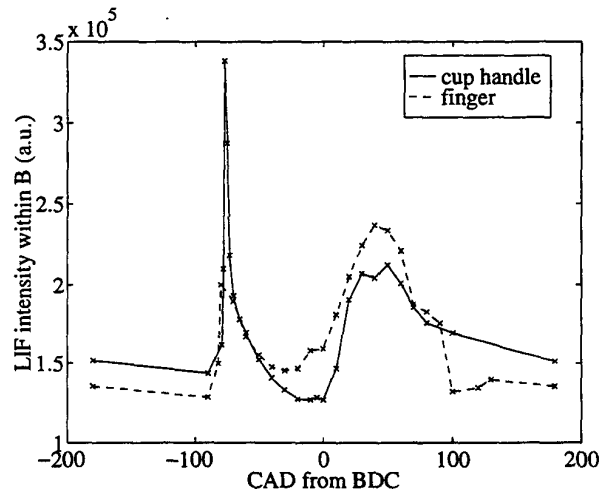

Figure 10b: Signal from mostly oil and partially burned fuel. Five percent 3-pentanone added to fuel..

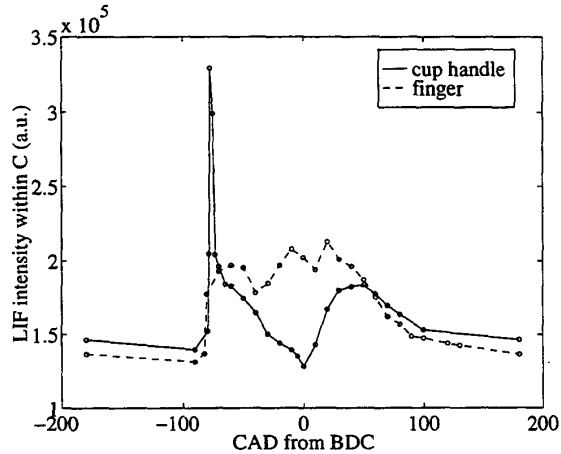

Figure 11a: Signal mainly from 3-pentanone. Two percent 3-pentanone added to fuel

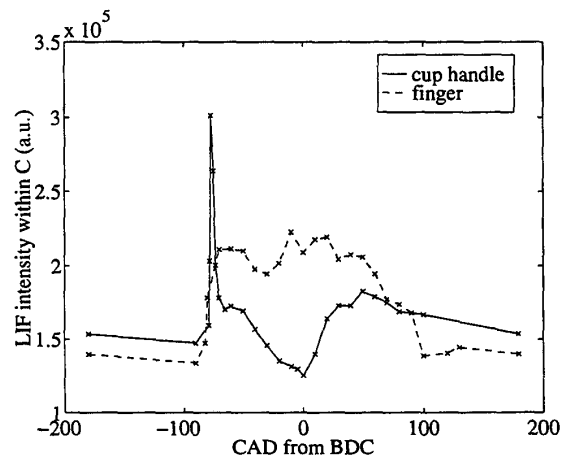

Figure 11b: Signal mainly from 3-pentanone. Five percent 3-pentanone added to fuel.

It was expected that signal would occur only late at the gas exchange where fresh gas is expected. The first peak can be the result of the tail of the spectral feature in region B, corresponding to oil and partially burned fuel. This tail reaches into region C, "leaking" information to this higher wavelength region. The higher level from the finger type indicates again that more short circuiting occurs in this cylinder. It can be noted that the signal level is increased with five per cent 3-pentanone compared to two per cent. This shows that the signal detected in this interval is mostly 3-pentanone.

As can be seen in the figures, the signal level continues to be high even after the closing of the exhaust port. This is due to the high working speed of the engine - the emissions do not have time to escape the measuring region before the next cycle begins and the exhaust port opens again.

VELOCITY MEASUREMENTS

In a former study on the two cylinder types, laser doppler velocimetry (LDV) was used to study the in-cylinder flow during gas exchange [17]. The same system has also been used to measure the flow outside the exhaust port. The measurement volume had the shape of an ellipsoid with a diameter of 0.1 mm and a length of approximately 7.5 mm. The system used was a DANTEC fiber-flow with BSA signal processors. More information on the system can be found in [17].

The measurement volume was placed in the center of the exhaust port and traversed over the port height. 196588 samples of velocity and crank angle position were collected for four different heights. The average horizontal velocity can be found in figure 12. The vertical component is lower and thus the velocity vector from both horizontal and vertical components has a shape similar to that of only the horizontal component, see figure 13.

The mean velocity can be used to estimate the time delay between events occurring at the exhaust port and detection 300 mm outside the port. With the engine speed set to 9000 rpm the time delay can be expressed in crank angle degrees. Figure 14 shows that the delay is smallest during the blowdown phase, resulting from a high mean velocity. In the latter stages, the mean velocity is lower and a substantial delay exists between the port and the measurement location.

PARTICLE FLUX - The LDV system needs particles to scatter light from the beam crossing. In these experiments, no addition of special particles was necessary. A fairly high data rate could be achieved on the naturally occurring particles. It is believed that these particles mainly consist of unburned or partially burned lubricating oil. The fuel used during the LDV measurements was commercial gasoline with a 2% oil content. The highest peak of data rate occurs during the blowdown phase for both cylinders, see figure 15.

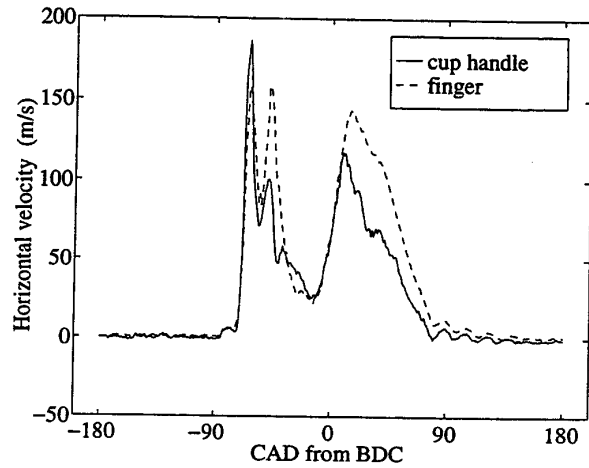

Figure 12: Horizontal velocity outside the exhaust port..

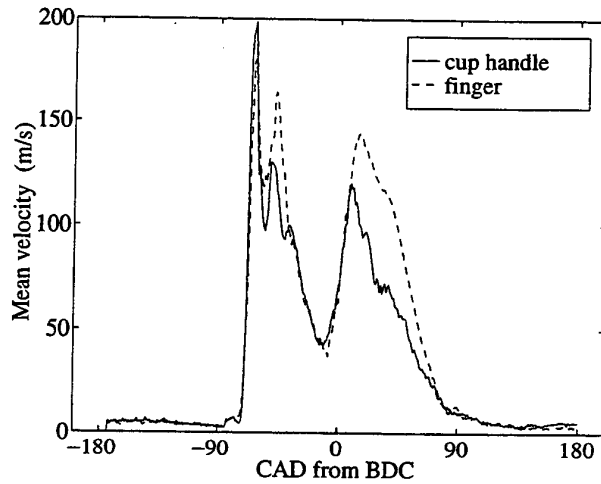

Figure 13: Mean velocity outside the exhaust port..

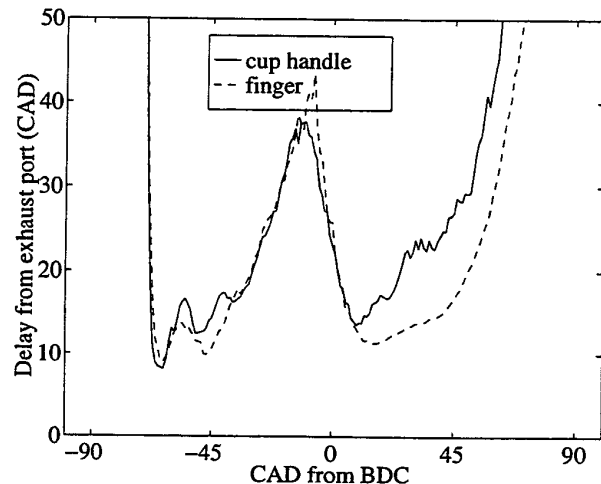

Figure 14: Delay from exhaust port to measurement location 30 mm from cylinder.

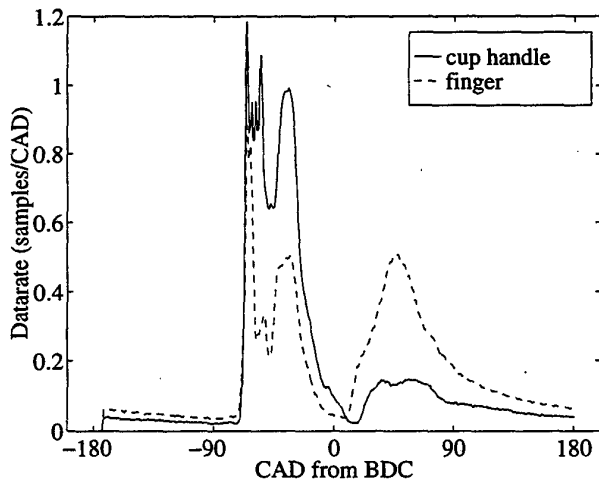

Figure 15: Data rate for LDV measurements, indicating the flux of naturally occurring particles.

This is somewhat surprising as charge escaping the cylinder during the blowdown phase has taken part in the combustion. Hence the oil should have been burned or at least evaporated. This is not the case. The latter peak in particle flux most likely originates from gas exchange short circuiting of fresh charge from transfer ports to exhaust port. The data rate from LDV is, however, only a very crude estimate on droplet flux. LDV is very sensitive to particle size and velocity bias [18] can play a major role. Despite these uncertainties some information can be obtained from the data rate.

Figure 15 shows that the cup-handle transfer channels have a lower secondary peak compared to the finger type. This is in agreement with the LIF measurements of the fuel concentration at the same location. The phasing between LIF and LDV data is, however, not the same. The second peak shows up later with LDV, than it does with LIF. This difference can be the result of several differences between the LDV and LIF measurements. The most important of these is the phase detected. LDV detects only the presence of particles. LIF on the other hand, detects a signal from both liquid and gas phase.

DISCUSSION

The results presented shows that LIF can be used to obtain information on the gas exchange process for high speed two-stroke engines. The imaging results are very similar to the spectral and an agreement can be found between Mie measurements with LIF and data rate detected with LDV.

There are, however, clear limitations. No attempt to calibrate the LIF signal levels to concentration of HC was performed. This can be a major difficulty as the

temperature of the exhaust gas will change significantly during the cycle. This means that we still must investigate how to relate the signal detected at the blowdown phase to that of the later second intensity peak.

The overall LIF signal as a function of crank angle position is shown in both figure 5, which comes from the imaging measurements, and figure 8a-b, which comes from the spectral measurements. These curves should in theory be identical. The reason why they differ from each other is explained by interferences from C_2 . During the imaging measurements the laser sheet was so tightly focused that the laser flux was sufficient to dissociate hydrocarbons and produce excited C_2 radicals [3]. During the spectral measurements these interferences were avoided by using a non focused laser sheet. However, a correlation between the strength of the C_2 fluorescence and the Mie scattering was observed. When the focusing lens was removed, the C_2 interference disappeared and the Mie scattering was enhanced. There is thus a possibility that C_2 fluorescence can be used for detecting the presence of fuel droplets.

CONCLUSIONS

Cycle resolved LIF measurements have been performed on simple, carbureted two-stroke engines working at 9000 rpm. There are two phases in the exhaust process of these engines. During the first phase combustion products are emitted, whereas fresh fuel is emitted during the second phase. This is due to fresh fuel-air mixture short circuiting the cylinder during the scavenging process. Two transfer channel configurations were investigated; one of finger type and one of cup-handle type. In the cup-handle case the two phases can be clearly separated, whereas for the finger-type cylinder there is an overlap between the phases. It has been shown that the finger geometry is less efficient in retaining the fresh charge in the cylinder than the cup-handle geometry.

ACKNOWLEDGEMENTS

We are indebted to the Swedish Board for Technical Development, NUTEK, for their financial support of this work.

REFERENCES

- [1] Heywood, J. B, Internal Combustion Engine Fundamentals, Mcgraw-Hill, 1988.
- [2] T. Summers and N. Collings, "Signal Reconstruction Applied to a Fast Response Flame Ionization Detector", SAE 952541, 1995.
- [3] Eckbreth, A.C. Laser Diagnostics for Combustion Temperature and Species, Abacus Press, 1987.

- [4] H. Neij, B. Johansson and M. Aldén, "Development and Demonstration of 2D-LIF for Studies of Mixture Preparation in SI Engines", *Combustion and Flame* 99:449-457, 1994.
- [5] C.H. Wang, X. Q. Liu and C. K. Law, *Combust. Flame* 56:175-197, 1984.
- [6] T. A. Baritaud and T. A. Heinze, "Gasoline Distribution Measurements with PLIF in a SI Engine", SAE 922355, 1992.
- [7] A. Arnold, H. Becker, R. Suntz, P. Monkhouse, J. Wolfrum, R. Maly and W. Pfitzer, *Opt. Lett.* 15:831-833, 1990.
- [8] N. P. Tait and D. A. Greenhalgh, *Twenty-Fourth Symposium (International) on Combustion*, The Combustion Institute, 1992, p. 1621-1628.
- [9] D. A. Stephenson, *Proceedings of the Scientific Applications of Lasers Symposium ICALEO '83*, laser institute of America, 1983, vol. 42, p.1.
- [10] P. H. Paul, I. Van Cruyningen, R. K. Hanson and G. Kychakoff, *Exp. Fluids* 9:241-251, 1990.
- [11] B. D. Smith and R. Srivastava, *Thermodynamic Data for Pure Compounds, Part A, Hydrocarbons and Ketones*, Elsevier, 1986.
- [12] W. Lawrentz, J. Köhler, F. Meijer, W. Stolts, R. Wirth, W. H. Bloss, R. R. Maly, E. Wagner and M. Zahn, SAE 922320, 1992.
- [13] M. Berckmüller, N. P. Tait, R. D. Lockett and D. A. Greenhalgh, K. Iishi, Y. Urata, H. Umiyama and K. Yoshida, *Twenty-Fifth Symposium (International) on Combustion*, The Combustion Institute, 1994, pp.151-156.
- [14] D. A. Hansen and E. K. C. Lee, *J. Chem. Phys.* 62:183-189, 1975.
- [15] P. Andresen, A. Bath, W. Gröger, H. W. Lülff, G. Meijer and J.J. ter Meulen, *Appl. Opt.* 27, 365, 1988.
- [16] P. J. Hargis, Jr., Paper published in *SPIE Proceedings* vol. 286 on *Laser Spectroscopy for Sensitive Detection*,
- [17] M. Ekenberg and B. Johansson, "The Effect of Transfer port Geometry on Scavenge Flow Velocities at High Engine Speed", SAE 960366, 1996.
- [18] D.K. McLaughlin, W.G. Tiederman: "Biasing correction for individual realization of laser anemometer measurements in turbulent flows", *The Physics of Fluids*, Vol. 16, Dec. 1973, pp2082-2088