

Crawling Ajax-based Web Applications through Dynamic Analysis of User Interface State Changes

Ali Mesbah, Arie van Deursen, and Stefan Lenselink

Report TUD-SERG-2011-033

TUD-SERG-2011-033

Published, produced and distributed by:

Software Engineering Research Group
Department of Software Technology
Faculty of Electrical Engineering, Mathematics and Computer Science
Delft University of Technology
Mekelweg 4
2628 CD Delft
The Netherlands

ISSN 1872-5392

Software Engineering Research Group Technical Reports:
<http://www.se.ewi.tudelft.nl/techreports/>

For more information about the Software Engineering Research Group:
<http://www.se.ewi.tudelft.nl/>

Note: *This paper is a pre-print of:*

Ali Mesbah, Arie van Deursen, and Stefan Lenselink, Crawling Ajax-based Web Applications through Dynamic Analysis of User Interface State Changes. *ACM Transactions on the Web*, 2012.

© copyright 2011, by the authors of this report. Software Engineering Research Group, Department of Software Technology, Faculty of Electrical Engineering, Mathematics and Computer Science, Delft University of Technology. All rights reserved. No part of this series may be reproduced in any form or by any means without prior written permission of the authors.

Crawling AJAX-based Web Applications through Dynamic Analysis of User Interface State Changes

ALI MESBAH, University of British Columbia
ARIE VAN DEURSEN, Delft University of Technology
STEFAN LENSELINK, Delft University of Technology

Using JAVASCRIPT and dynamic DOM manipulation on the client-side of web applications is becoming a widespread approach for achieving rich interactivity and responsiveness in modern web applications. At the same time, such techniques, collectively known as AJAX, shatter the metaphor of web ‘pages’ with unique URLs, on which traditional web crawlers are based. This paper describes a novel technique for crawling AJAX-based applications through automatic dynamic analysis of user interface state changes in web browsers. Our algorithm scans the DOM-tree, spots candidate elements that are capable of changing the state, fires events on those candidate elements, and incrementally infers a state machine modelling the various navigational paths and states within an AJAX application. This inferred model can be used, for instance, in program comprehension, analysis and testing of dynamic web states, or for generating a static version of the application. In this paper, we discuss our sequential and concurrent AJAX crawling algorithms. We present our open source tool called CRAWLJAX, which implements the concepts and algorithms discussed in this paper. Additionally, we report a number of empirical studies in which we apply our approach to a number of open-source and industrial web applications and elaborate on the obtained results.

Categories and Subject Descriptors: H.5.4 [Information Interfaces and Presentation]: Hypertext/Hypermedia—Navigation; H.3.3 [Information Search and Retrieval]: Search process; D.2.2 [Software Engineering]: Design Tools and Techniques

General Terms: Design, Algorithms, Experimentation.

Additional Key Words and Phrases: Crawling, ajax, web 2.0, hidden web, dynamic analysis, dom crawling

ACM Reference Format:

Mesbah, A., van Deursen, A., and Lenselink, S. 2011. Crawling AJAX-based Web Applications through Dynamic Analysis of User Interface State Changes ACM Trans. Web 0, 0, Article 0 (2011), 30 pages. DOI = 10.1145/0000000.0000000 <http://doi.acm.org/10.1145/0000000.0000000>

1. INTRODUCTION

The web as we know it is undergoing a significant change. A technology that has gained a prominent position lately, under the umbrella of *Web 2.0*, is AJAX (Asynchronous JAVASCRIPT and XML) [Garrett 2005], in which the combination of JAVASCRIPT and Document Object Model (DOM) manipulation, along with asynchronous server com-

This is a substantially revised and expanded version of our paper ‘Crawling AJAX by Inferring User Interface State Changes’, which appeared in the *Proceedings of the 8th International Conference on Web Engineering (ICWE)*, IEEE Computer Society, 2008 [Mesbah et al. 2008].

Authors’ address: A. Mesbah is with the department of Electrical and Computer Engineering, University of British Columbia, 2332 Main Mall, V6T1Z4 Vancouver, BC, Canada. E-mail: amesbah@ece.ubc.ca

A. van Deursen and S. Lenselink are with the Faculty of Electrical Engineering, Mathematics and Computer Science, Delft University of Technology, Mekelweg 4, 2628CD Delft, The Netherlands. E-mail: arie.vandeursen@tudelft.nl and S.R.Lenselink@student.tudelft.nl

Permission to make digital or hard copies of part or all of this work for personal or classroom use is granted without fee provided that copies are not made or distributed for profit or commercial advantage and that copies show this notice on the first page or initial screen of a display along with the full citation. Copyrights for components of this work owned by others than ACM must be honored. Abstracting with credit is permitted. To copy otherwise, to republish, to post on servers, to redistribute to lists, or to use any component of this work in other works requires prior specific permission and/or a fee. Permissions may be requested from Publications Dept., ACM, Inc., 2 Penn Plaza, Suite 701, New York, NY 10121-0701 USA, fax +1 (212) 869-0481, or permissions@acm.org.

© 2011 ACM 1559-1131/2011/-ART0 \$10.00

DOI 10.1145/0000000.0000000 <http://doi.acm.org/10.1145/0000000.0000000>

munication is used to achieve a high level of user interactivity. Highly visible examples include Gmail and Google Docs.

With this new change in developing web applications comes a whole set of new challenges, mainly due to the fact that AJAX shatters the metaphor of a web ‘page’ upon which many web technologies are based. Among these challenges are the following:

- Searchability.* ensuring that AJAX sites are crawled and indexed by the general search engines, instead of (as is currently often the case) being ignored by them because of the use of client-side scripting and dynamic state changes in the DOM;
- Testability.* systematically exercising dynamic user interface (UI) elements and analyzing AJAX states to find abnormalities and errors;

One way to address these challenges is through the use of a crawler that can automatically walk through different states of a highly dynamic AJAX site and create a model of the navigational paths and states.

General web search engines, such as Google and Bing, cover only a portion of the web called the *publicly indexable web* that consists of the set of web pages reachable purely by following hypertext links, ignoring forms [Barbosa and Freire 2007] and client-side scripting. The web content behind forms and client-side scripting is referred to as the *hidden-web*, which is estimated to comprise several millions of pages [Barbosa and Freire 2007]. With the wide adoption of AJAX techniques that we are witnessing today this figure will only increase. Although there has been extensive research on crawling and exposing the data behind forms [Barbosa and Freire 2007; de Carvalho and Silva 2004; Lage et al. 2004; Ntoulas et al. 2005; Raghavan and Garcia-Molina 2001], crawling the hidden-web induced as a result of client-side scripting has gained very little attention so far.

Crawling AJAX-based applications is fundamentally more difficult than crawling classical multi-page web applications. In traditional web applications, states are explicit, and correspond to pages that have a unique URL assigned to them. In AJAX applications, however, the state of the user interface is determined dynamically, through changes in the DOM that are only visible after executing the corresponding JAVASCRIPT code.

In this paper, we propose an approach to analyze these user interface states automatically. Our approach is based on a crawler that can exercise client-side code and identify clickable elements (which may change with every click) that change the state within the browser’s dynamically built DOM. From these state changes, we infer a *state-flow graph*, which captures the states of the user interface and the possible transitions between them. The underlying ideas have been implemented in an open source tool called CRAWLJAX.¹ To the best of our knowledge, CRAWLJAX is the first and currently the only available tool that can detect dynamic contents of AJAX-based web applications automatically without requiring specific URLs for each web state.

The inferred model can be used, for instance, to expose AJAX sites to general search engines or to examine the accessibility [Atterer and Schmidt 2005] of different dynamic states. The ability to automatically exercise all the executable elements of an AJAX site gives us a powerful test mechanism. CRAWLJAX has successfully been used for conducting automated model-based and invariant-based testing [Mesbah and van Deursen 2009], security testing [Bezemer et al. 2009], regression testing [Roest et al. 2010], and cross-browser compatibility testing [Mesbah and Prasad 2011] of AJAX web applications.

We have performed a number of empirical studies to analyze the overall performance of our approach. We evaluate the effectiveness in retrieving relevant clickables and as-

¹ <http://crawljax.com>

Crawling AJAX-based Web Applications through Dynamic Analysis of User Interface State Changes 0:3

sess the quality and correctness of the detected states and edges. We also examine the performance of our crawling tool as well as the scalability in crawling AJAX applications with a large number of dynamic states and clickables. The experimental benchmarks span from open source to industrial web applications.

This paper is a revised and extended version of our original paper in 2008 [Mesbah et al. 2008]. The extensions in this paper are based on three years of tool usage and refinements. In addition, we report on our new multi-threaded, multi-browser crawling approach as well as a new (industrial) empirical study, evaluating its influence on the runtime performance. The results of our study show that by using 5 browsers instead of 1, we can achieve a decrease of up to 65% in crawling runtime.

The paper is further structured as follows. We start out, in Section 2 by exploring the difficulties of crawling AJAX. In Section 3 we present a detailed discussion of our AJAX crawling algorithm and technique. In Section 4, we extend our sequential crawling approach to a concurrent multiple-browser crawling algorithm. Section 5 discusses the implementation of our tool CRAWLJAX. In Section 6, the results of applying our techniques to a number of AJAX applications are shown, after which Section 7 discusses the findings and open issues. We conclude with a survey of related work, a summary of our key contributions and suggestions for future work.

2. CHALLENGES OF CRAWLING AJAX

AJAX-based web applications have a number of properties that make them very challenging to crawl automatically.

2.1. Client-side Execution

The common ground for all AJAX applications is a JAVASCRIPT engine, which operates between the browser and the web server [Mesbah and van Deursen 2008]. This engine typically deals with server communication and user interface modifications. Any search engine willing to approach such an application must have support for the execution of the scripting language. Equipping a crawler with the necessary environment complicates its design and implementation considerably. The major search engines such as Google and Bing currently have little or no support for executing scripts and thus ignore content produced by JAVASCRIPT,² due to scalability and security issues.

2.2. State Changes and Navigation

Traditional web applications are based on the multi-page interface paradigm consisting of multiple pages each having a unique URL. In AJAX applications, not every state change necessarily has an associated REST-based [Fielding and Taylor 2002] URI. Ultimately, an AJAX application could consist of a single-page with a single URL [Mesbah and van Deursen 2007]. This characteristic makes it difficult for a search engine to index and point to a specific state in an AJAX application. Crawling traditional web pages constitutes extracting and following the hypertext links (the src attribute of anchor tags) on each page. In AJAX, hypertext links can be replaced by events which are handled by JAVASCRIPT; i.e., it is not possible any longer to navigate the application by simply extracting and retrieving the internal hypertext links.

2.3. Dynamic Document Object Model (DOM)

Crawling and indexing traditional web applications consists of following links, retrieving and saving the HTML source code of each page. The state changes in AJAX applications are dynamically represented through the run-time changes on the DOM-tree in the browser. This means that the initial HTML source code retrieved from the server

² <http://code.google.com/web/ajaxcrawling/docs/getting-started.html>

0:4

Mesbah et al.

```

1 <A href="javascript:OpenNewsPage();">...
2 <A href="#" onClick="OpenNewsPage();">...
3 <DIV onClick="OpenNewsPage();">...

5 <DIV class="news"/>
6 <SPAN id="content"/>
7 <!-- jQuery function attaching events to elements having attribute class="news".
8 The news contents are injected into the SPAN element -->
9 <script>
10 $(".news").click(function() {
11     $("#content").load("news.html");
12 });
13 </script>

```

Fig. 1: Different ways of attaching events to elements.

does not represent the state changes. An AJAX crawler will need to have access to this run-time dynamic document object model of the application.

2.4. Delta-communication

AJAX applications rely on a delta-communication [Mesbah and van Deursen 2008] style of interaction in which merely the state changes are exchanged asynchronously between the client and the server, as opposed to the full-page retrieval approach in traditional web applications. Retrieving and indexing the data served by the server, for instance, through a proxy between the client and the server, could have the side-effect of losing the context and actual meaning of the changes because most of such updates become meaningful after they have been processed by the JAVASCRIPT engine on the client and injected into the runtime DOM-tree.

2.5. Clickable Elements Changing the Internal State

To illustrate the difficulties involved in crawling AJAX, consider Figure 1. It is a highly simplified example, showing different ways in which a news page can be opened. The example code shows how in AJAX, it is not just the hypertext link element that forms the doorway to the next state. Note the way events (e.g., `onClick`, `onMouseOver`) can be attached to DOM elements at run-time. As can be seen, a `DIV` element (line 3) can have an `onClick` event attached to it so that it becomes a *clickable* element capable of changing the internal DOM state of the application when clicked.

Event handlers can also be dynamically registered using JAVASCRIPT. The jQuery³ code (lines 5–13) attaches a function to the `onClick` event listener of the element with `class` attribute `news`. When this element is clicked, the news content is retrieved from the server and injected into the `SPAN` element with `ID` `content`.

There are different ways to attach event listeners to DOM elements. For instance, if we have the following handler:

```
var handler = function() { alert('Element clicked!') };
```

we can attach it to an `onClick` listener of a DOM element `e` in the following ways:

```

(1) e.onclick = handler;

(2) if(e.addEventListener) {
    e.addEventListener('click', handler, false)
  } else if(e.attachEvent) { // IE
    e.attachEvent('onclick', handler)
  }

```

³ <http://jquery.com>

Crawling AJAX-based Web Applications through Dynamic Analysis of User Interface State Changes0:5

The first case presents the traditional way of attaching handlers to DOM elements. In this case, we can examine the DOM element at runtime and find out that it has the handler attached to its `onClick` attribute. The second case show how handlers could be attached to DOM elements through the DOM Level 2 API. In this case, however, by examining the DOM element it is not possible to find information about the handler, since the event model (DOM Level 2 Events [Pixley 2000]) maintaining the handler registration information is separated from the DOM core model itself. Hence, automatically finding these clickable elements at runtime is another non-trivial task for an AJAX crawler.

3. A METHOD FOR CRAWLING AJAX

The challenges discussed in the previous section should make it clear that crawling AJAX is more demanding than crawling the classical web. In this section, we propose a *dynamic analysis* approach, in which we open the AJAX application in a browser, scan the DOM-tree for candidate elements that are capable of changing the state, fire events on those elements, and analyze the effects on the DOM-tree. Based on our analysis, we infer a *state-flow graph* representing the user interface states and possible transitions between them.

In this section, we first present the terminology used in this paper followed by a discussion of the most important components of our crawling technique, as depicted in Figure 3.

3.1. Terminology

3.1.1. User Interface State and State Changes. In traditional multi-page web applications, each state is represented by a URL and the corresponding web page. In AJAX however, it is the internal structure of the DOM-tree of the (single-page) user interface that represents a state. Therefore, to adopt a generic approach for all AJAX sites, we define a state change as a change on the DOM tree caused by (1) either client-side events handled by the AJAX engine; (2) or server-side state changes propagated to the client.

3.1.2. State Transition and Clickable. On the browser, the end-user can interact with the web application through the user interface: click on an element, bring the mouse-pointer over an element, and so on. These actions can cause events that, as described above, can potentially change the state of the application. We call all DOM elements that have event-listeners attached to them and can cause a state transition, *clickable* elements. For the sake of simplicity, we use the *click* event type to present our approach, note, however, that other event types can be used just as well to analyze the effects on the DOM in the same manner.

3.1.3. The State-flow Graph. To be able to navigate an AJAX-based web application, the application can be modelled by recording the click trails to the various user interface state changes. To record the states and transitions between them, we define a *state-flow graph* as follows:

DEFINITION 1. A **state-flow graph** G for an AJAX site A is a labeled, directed graph, denoted by a 4 tuple $\langle r, V, E, \mathcal{L} \rangle$ where:

- (1) r is the root node (called *Index*) representing the initial state after A has been fully loaded into the browser.
- (2) V is a set of vertices representing the states. Each $v \in V$ represents a runtime DOM state in A .
- (3) E is a set of (directed) edges between vertices. Each $(v_1, v_2) \in E$ represents a *clickable* c connecting two states if and only if state v_2 is reached by executing c in state v_1 .

0:6

Mesbah et al.

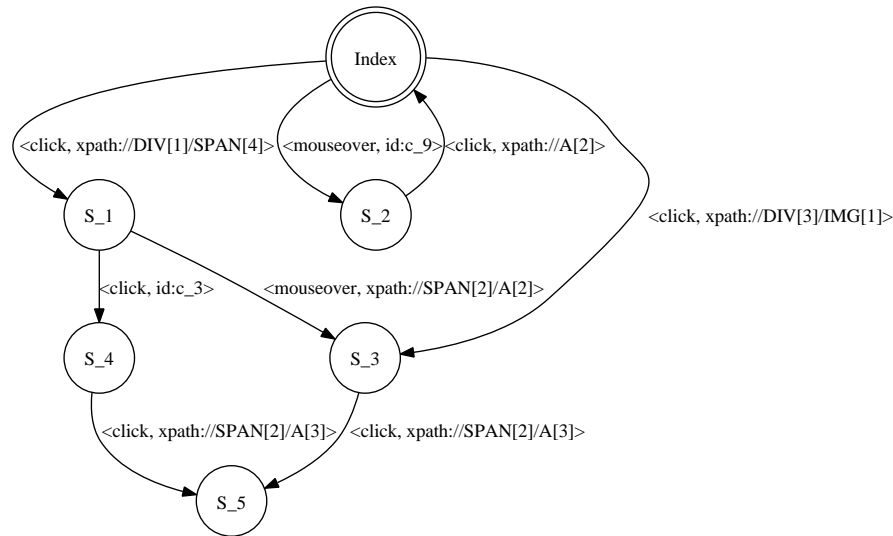

Fig. 2: The state-flow graph visualization.

- (4) \mathcal{L} is a labelling function that assigns a label, from a set of event types and DOM element properties, to each edge.
 (5) G can have multi-edges and be cyclic.

As an example of a state-flow graph, Figure 2 depicts the visualization of the state-flow graph of a simple AJAX site. The edges between states are labeled with an identification (either via its ID-attribute or via an XPath expression) of the clickable. Thus, clicking on the `//DIV[1]/SPAN[4]` element in the Index state leads to the S_1 state, from which two states are directly reachable namely S_3 and S_4.

The state-flow graph is created incrementally. Initially, it only contains the root state and new states are created and added as the application is crawled and state changes are analyzed.

The following components, also shown in Figure 3, participate in the construction of the state-flow graph:

- **Embedded Browser:** The embedded browser provides a common interface for accessing the underlying engines and runtime objects, such as the DOM and JAVASCRIPT.
- **Robot:** A robot is used to simulate user actions (e.g., `click`, `mouseover`, `text input`) on the embedded browser.
- **Controller:** The controller has access to the embedded browser's DOM. It also controls the Robot's actions and is responsible for updating the state machine when relevant changes occur on the DOM.
- **DOM Analyzer:** The analyzer is used to check whether the DOM-tree is changed after an event has been fired by the robot. In addition, it is used to compare DOM-trees when searching for duplicate-states in the state machine.
- **Finite State Machine:** The finite state machine is a data component maintaining the state-flow graph, as well as a pointer to the state being currently crawled.

Crawling AJAX-based Web Applications through Dynamic Analysis of User Interface State Changes

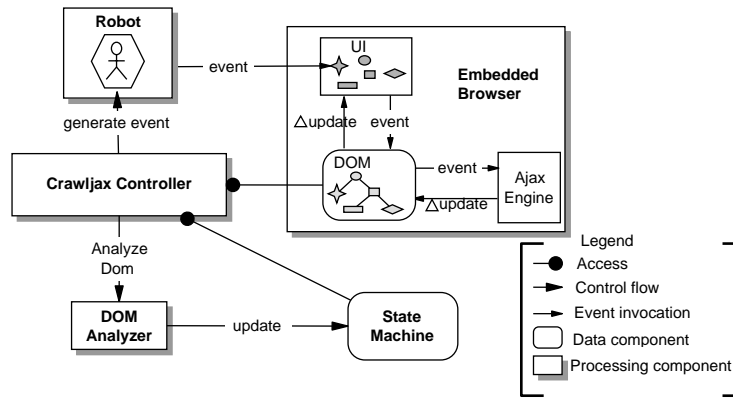

Fig. 3: Processing view of the crawling architecture.

3.2. Inferring the State Machine

The algorithm used by these components to actually infer the state machine is shown in Algorithm 1. The main procedure (lines 1-5) takes care of initializing the various components and processes involved. The actual, recursive, crawl procedure starts at line 6. The main steps of the crawl procedure are explained below.

ALGORITHM 1: Crawling AJAX

```

input : URL, tags, browserType
1 Procedure MAIN()
2 begin
3   global browser ← INITEMBEDDEDBROWSER(URL, browserType)
4   global robot ← INITROBOT()
5   global sm ← INITSTATEMACHINE()
6   CRAWL(null)

7 Procedure CRAWL(State ps)
8 begin
9   cs ← sm.GETCURRENTSTATE()
10  Δupdate ← DIFF(ps, cs)
11  f ← ANALYSEFORMS(Δupdate)
12  Set C ← GETCANDIDATECLICKABLES(Δupdate, tags, f)
13  for c ∈ C do
14    robot.ENTRFORMVALUES(c)
15    robot.FIREEVENT(c)
16    dom ← browser.GETDOM()
17    if STATECHANGED(cs.GETDOM(), dom) then
18      xe ← GETXPATHEXPR(c)
19      ns ← sm.ADDSTATE(dom)
20      sm.ADDEEDGE(cs, ns, EVENT(c, xe))
21      sm.CHANGETOSTATE(ns)
22      if STATEALLOWEDTOBECRAWLED(ns) then
23        CRAWL(cs)
24      sm.CHANGETOSTATE(cs)
25      BACKTRACK(cs)

```

3.3. Detecting Clickables

There is no feasible way of automatically obtaining a list of all clickable elements on a DOM-tree, due to the reasons explained in Section 2. Therefore, our algorithm makes use of a set of *candidate elements*, which are all exposed to an event type (e.g., click, mouseOver). Each element on the DOM-tree that meets the labelling requirements is selected as a candidate element.

In automated mode, the candidate clickables are labeled as such based on their HTML tag element name. In our implementation, all elements with a tag `<A>`, `<BUTTON>`, or `<INPUT type='submit'>` are considered as candidate clickables, by default. The selection of candidate clickables can be relaxed or constrained by the user as well, by defining element properties such as the XPATH position on the DOM-tree, attributes and their values, and text values. For instance, the user could be merely interested in examining DIV elements with attribute `class='article'`. It is also possible to exclude certain elements from the crawling process.

Based on the given definition of the candidate clickables, our algorithm scans the DOM-tree and extracts all the DOM elements that meet the requirements of the definition (line 12). For each extracted candidate element, the crawler then instructs the robot to fill in the detected data entry points (line 14) and fire an event (line 15) on the element in the browser. The robot is currently capable of using either self-generated random values, or custom values provided by the user to fill in the forms (for more details on the form filling capabilities see [Mesbah and van Deursen 2009]).

DEFINITION 2. *Let D_1 be the DOM-tree of the state before firing an event e on a candidate clickable cc and D_2 the DOM-tree after e is fired, then cc is a clickable if and only if D_1 differs from D_2 .*

3.4. State Comparison

After firing an event on a candidate clickable, the algorithm compares the resulting DOM-tree with the DOM-tree as it was just before the event fired, in order to determine whether the event results in a state change (line 17).

To detect a state change, the DOM-trees need to be compared. One way of comparing them is by calculating the *edit distance* between two DOM-trees is calculated, using the Levenshtein [1996] method. A similarity threshold τ is used under which two DOM trees are considered clones. This threshold (0.0–1.0) can be given as input. A threshold of 0 means two DOM states are seen as clones if they are *exactly* the same in terms of structure and content. Any change is, therefore, seen as a state change.

Another way of comparing the states we have proposed recently [Roest et al. 2010], is the use of a series of *comparators*, each capable of focusing on and comparing specific aspects of two DOM-trees. In this technique, each comparator filters out specific parts of the DOM-tree and passes the output to the next comparator. For instance, a `Datetime` comparator looks for any date/time patterns and filters those. This way, two states containing different timestamps can be marked similar automatically.

If a state change is detected, according to our comparison heuristics, we create a new state and add it to the state-flow graph of the state machine (line 19).

The `ADDSTATE` call works as follows: In order to recognize an already met state, we compare every new state to the list of already visited states on the state-flow graph. If we recognize an identical or similar state in the state machine (based on the same similarity notion used for detecting a new state after an event) that state is used for adding a new edge, otherwise a new state is created and added to the graph.

As an example, Figure 4a shows the full state space of a simple application, before any similarity comparison heuristics. In Figure 4c, the states that are identical (S_4)

Crawling AJAX-based Web Applications through Dynamic Analysis of User Interface State Changes 0:9

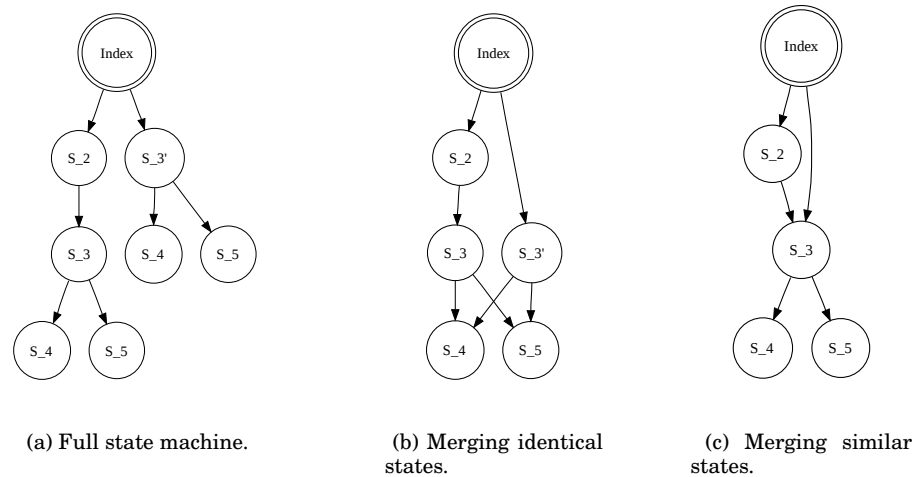

Fig. 4: State Machine Optimization.

are merged and Figure 4c presents the state space after similar states (S_3 and S_3') have been merged.

For every detected state, a new edge is created on the graph between the state before the event and the current state (line 20). Using properties such as the XPATH expression, the clickable causing the state transition is also added as part of the new edge (line 18).

Moreover, the current state pointer of the state machine is updated to this newly added state at that moment (line 21).

3.5. Processing Document Tree Deltas

After a clickable has been identified, and its corresponding state transition created, the CRAWL procedure is recursively called (line 23) to find possible states reachable from the newly detected state.

Upon every new (recursive) entry into the CRAWL procedure, the first action taken (line 10) is computing the differences between the previous document tree and the current one, by means of an enhanced *Diff* algorithm [Chawathe et al. 1996; Mesbah and van Deursen 2007]. The resulting differences are used to find new candidate clickables, which are then further processed by the crawler. Such “delta updates” may be due, for example, to a server request call that injects new elements into the DOM.

It is worth mentioning that in order to avoid a loop, a list of visited elements is maintained to exclude already checked elements in the recursive algorithm. We use the tag name, the list of attribute names and values, and the XPath expression of each element to conduct the comparison. Additionally, a depth-level number can be defined to constrain the depth level of the recursive function.

3.6. Backtracking to the Previous State

Upon completion of the recursive call, the browser should be put back into the state it was in before the call, at least if there are still unexamined clickable elements left on that state.

Unfortunately, navigating (back and forth) through an AJAX site is not as easy as navigating a classical multi-page one. A dynamically changed DOM state does not reg-

0:10

Mesbah et al.

ALGORITHM 2: Backtracking

```

input :
1 Procedure BACKTRACK(State s)
2 begin
3   cs ← s
4   while cs.HASPREVIOUSSTATE() do
5     ps ← cs.GETPREVIOUSSTATE()
6     if ps.HASUNEXAMINEDCANDIDATECLICKABLES() then
7       if browser.history.CANGOBACK() then
8         | browser.history.GOBACK()
9       else
10        | browser.RELOAD()
11        | List E ← sm.GETPATHTO(ps)
12        | for e ∈ E do
13          | re ← RESOLVEELEMENT(e)
14          | robot.ENTERFORMVALUES(re)
15          | robot.FIREEVENT(re)
16        | return
17      else
18        | cs ← ps

```

ister itself with the browser history engine automatically, so triggering the ‘Back’ function of the browser usually does not bring us to the previous state. Saving the whole browser state is also not feasible due to many technical difficulties. This complicates traversing the application when crawling AJAX. Algorithm 2 shows our backtracking procedure.

The backtracking procedure is called once the crawler is done with a certain state (line 25 in Algorithm 1). Algorithm 2 first tries to find the relevant previous state that still has unexamined candidate clickables (lines 4-18 in Algorithm 2).

If a relevant previous state is found to backtrack to (line 6 in Algorithm 2), then we distinguish between two situations:

Browser History Support It is possible to programmatically register each state change with the browser history through frameworks such as the jQuery history/remote plugin⁴, the Really Simple History library,⁵ or the recently proposed HTML5 history manipulation API (e.g., `history.pushState()` and `history.replaceState()`).⁶ If an AJAX application has support for the browser history (line 7), then for changing the state in the browser, we can simply use the built-in history back functionality to move backwards (line 8 in Algorithm 2).

Clicking Through From Initial State In case the browser history is not supported, which is the case with many AJAX applications currently, the approach we propose to get to a previous state is by saving information about the clickable elements, the event type (e.g., click), and the order in which the events fired on the elements results in reaching to a particular state. Once we possess such information, we can reload the application (line 10 in Algorithm 2) and fire events on the clickable elements from the initial state to the desired state, using the *exact* path taken to reach that state (line 11 in Algorithm 2). However, as an optimization step, it is also possible to use Dijkstra’s shortest path algorithm [Dijkstra 1959] to find the shortest element/event

⁴ <http://stilbuero.de/jquery/history/>

⁵ <http://code.google.com/p/reallysimplehistory/>

⁶ www.w3.org/TR/html5/history.html

Crawling AJAX-based Web Applications through Dynamic Analysis of User Interface State Changes 0:11

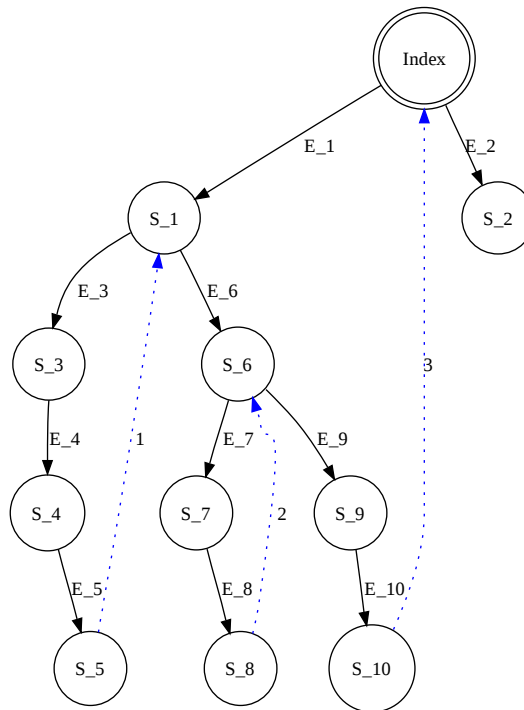

Fig. 5: Backtracking to the previous relevant state.

path on the graph to a certain state. For every element along the path, we first check whether the element can be found on the current DOM-tree and try to resolve it using heuristics to find the best match possible (line 13 in Algorithm 2). Then, after filling in the related input fields (line 14 in Algorithm 2), we fire an event on the element (line 15 in Algorithm 2).

We adopt XPath along with its attributes to provide a better, more reliable, and persistent element identification mechanism. For each clickable, we reverse engineer the XPath expression of that element, which gives us its exact location on the DOM (line 18 in Algorithm 1). We save this expression in the state machine (line 20 in Algorithm 1) and use it to find the element after a reload, persistently (line 13 in Algorithm 2).

Figure 5 shows an example of how our backtracking mechanism operates. Lets assume that we have taken the (E_1, E_3, E_4, E_5) path and have landed on state S_5. From S_5, our algorithm knows that there are no candidate clickables left in states S_4 and S_3 by keeping the track of examined elements. S_1, however, does contain an unexamined clickable element. The dotted blue line annotated with 1 shows our desired path for backtracking to this relevant previous state. To go from S_5 to S_1, the algorithm reloads the browser so that it lands on the index state, and from there it fires an event on the clickable E_1.

0:12

Mesbah et al.

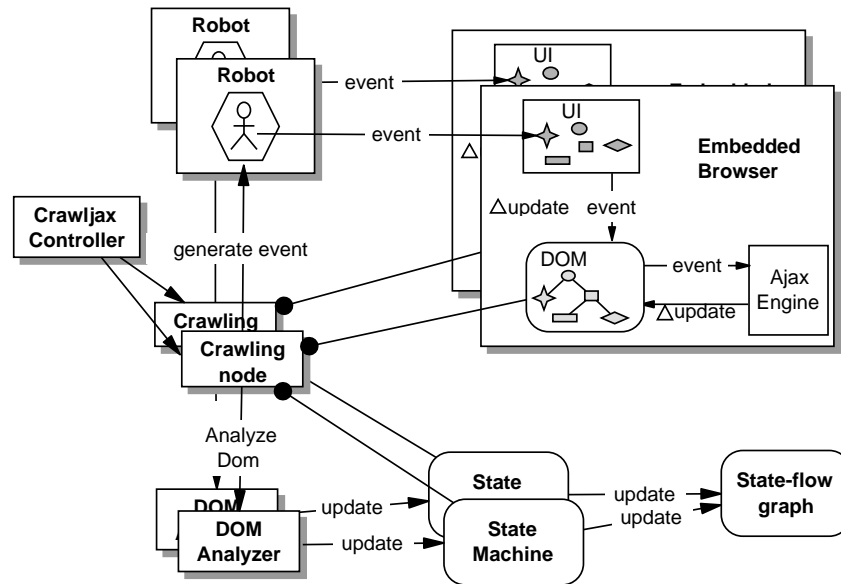

Fig. 6: Processing view of the concurrent crawling architecture.

4. CONCURRENT AJAX CRAWLING

The algorithm and its implementation for crawling AJAX as just described is sequential, depth-first, and single-threaded. Since we crawl the web application dynamically, the crawling runtime is determined by:

- (1) the speed at which the web server responds to HTTP requests;
- (2) network latency;
- (3) the crawler's internal processes (e.g., analyzing the DOM, firing events, updating the state machine);
- (4) the speed of the browser in handling the events and request/response pairs, modifying the DOM, and rendering the user interface,

We have no influence on the first two factors and we already have many optimization heuristics for the third step (See Section 3). Therefore, in this section we focus on the last factor, the browser. Since the algorithm has to wait some considerable amount of time for the browser to finish its tasks after each event, our hypothesis is that we can decrease the total runtime by adopting concurrent crawling through multiple browsers.

4.1. Multi-threaded, Multi-Browser Crawling

Figure 6 shows the processing view of our concurrent crawling. The idea is to maintain a single state machine and split the original *controller* into a new controller and multiple *crawling nodes*. The controller is the single main thread monitoring the total crawl procedure. In this new setting, each crawling node is responsible for deriving its corresponding robot and browser instances to crawl a specific path.

Compared with Figure 3, the new architecture is capable of having multiple crawler instances, running from a single controller. All the crawlers share the same state machine. The state machine makes sure every crawler can read and update the state machine in a synchronized way. This way, the operation of discovering new states can be executed in parallel.

Crawling AJAX-based Web Applications through Dynamic Analysis of User Interface State Changes0:13

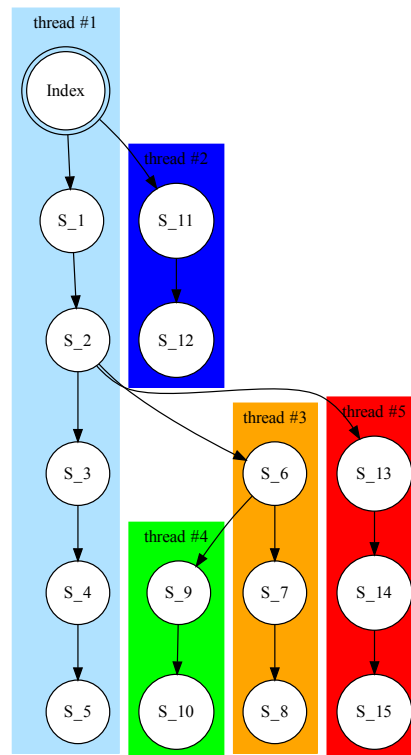

Fig. 7: Partitioning the state space for multi-threaded crawling.

4.2. Partition Function

To divide the work over the crawlers in a multi-threaded manner, a partition function must be designed. The performance of a concurrent approach is determined by the quality of its partition function [Garavel et al. 2001]. A partition function can be either static or dynamic. With a static partition function the division of work is known in advance, before executing the code. When a dynamic partition function is used, the decision of which thread will execute a given node is made at runtime. Our algorithm infers the state-flow graph of an AJAX application dynamically and incrementally. Thus, due to this dynamic nature we adopt for a dynamic partition function.

The task of our dynamic partition function is to distribute the work equally over all the participating crawling nodes. While crawling an AJAX application, we define *work* as: Bringing the browser back into a given state and exploring the first unexplored candidate state from that state. Our proposed partition function operates as follows: After the discovery of a new state, if there are still unexplored candidate clickables left in the previous state, that state is assigned to another thread for further exploration. The processor chosen will be the one with the least amount of work left.

Figure 7 visualizes our partition function for concurrent crawling of a simple web application. In the Index state, two candidate clickables are detected that can lead to: S_1 and S_11. The initial thread continues with the exploration of the states S_1,

0:14

Mesbah et al.

S₂, S₃, S₄ and finishes in S₅ in a depth-first manner. Simultaneously, a new thread is branched off to explore state S₁₁. This new thread (thread #2) first reloads the browser to Index and after that goes into S₁₁. In state S₂ and S₆ this same branching mechanism happens, which results in a total of 5 threads.

Now that the partition function has been introduced, the original sequential crawling algorithm (Algorithm 1) can be changed into a concurrent version.

4.3. The Concurrent Crawling Algorithm

The concurrent crawling approach is shown in Algorithm 3. Here we briefly explain the main differences with respect to the original sequential crawling algorithm, as presented in Algorithm 1 and discussed in Section 3.

Global State-flow Graph The first change is the separation of the state-flow graph from the state machine. The graph is defined in a global scope (line 3), so that it can be centralized and used by all concurrent nodes. Upon the start of the crawling process, an initial crawling node is created (line 5) and its RUN procedure is called (line 6).

Browser Pool The robot and state machine are created for each crawling node. Thus, they are placed in the local scope of the RUN procedure (lines 10-11).

Generally, each node needs to acquire a browser instance and after the process is finished, the browser is killed. Creating new browser instances is a process-intensive and time-consuming operation. To optimize, a new structure is introduced: the BrowserPool (line 4), which creates and maintains browsers in a pool of browsers to be re-used by the crawling nodes. This reduces start-up and shut-down costs. The BrowserPool can be queried for a browser instance (line 9), and when a node is finished working, the browser used is released back to the pool.

In addition, the algorithm now takes the desired number of browsers as input. Increasing the number of browsers used can decrease the crawling runtime, but it also comes with some limitations and trade-offs that we will discuss in Section 6.5.

Forward-tracking In the sequential algorithm, after finishing a crawl path, we need to bring the crawler to the previous (relevant) state. In the concurrent algorithm, however, we create a new crawling node for each path to be examined (see Figure 7). Thus, instead of bringing the crawler back to the desired state (backtracking) we must take the new node forward to the desired state, hence, forward-tracking.

This is done after the *browser* is pointed to the URL (line 12). The first time the RUN procedure is executed, there is no forward-tracking taking place, since the event-path (i.e., the list of clickable items resulting to the desired state) is empty, so the initial crawler starts from the Index state. However, if the event-path is not empty, the clickables are used to take the browser forward to the desired state (lines 13-16). At that point, the CRAWL procedure is called (line 17).

Crawling Procedure The first part of the CRAWL procedure is unchanged (lines 21-24). To enable concurrent nodes accessing the candidate clickables in a thread-safe manner, the body of the for loop is synchronized around the candidate element to be examined (line 26). To avoid examining a candidate element multiple times by multiple nodes, each node first checks the examined state of the candidate element (line 28). If the element has not been examined previously, the robot executes an event on the element in the browser and sets its state as examined (line 31). If the state is changed, before going into the recursive CRAWL call, the PARTITION procedure is called (line 38).

Partition Procedure The partition procedure, called on a particular state *cs* (line 44), creates a new crawling node for every unexamined candidate clickable in *cs* (line

Crawling AJAX-based Web Applications through Dynamic Analysis of User Interface State Changes 0:15

ALGORITHM 3: Concurrent AJAX Crawling

```

input : URL, tags, browserType, nrOfBrowsers
1 Procedure MAIN()
2 begin
3   global sfg ← INITSTATEFLOWGRAPH()
4   global browserPool ← INITBROWSERPOOL(nrOfBrowsers, browserType)
5   crawlingNode ← CRAWLINGNODE()
6   crawlingNode.RUN(null, null)
7 Procedure RUN(State s, EventPath ep)
8 begin
9   browser ← browserPool.GETEMBEDDEDBROWSER()
10  robot ← INITROBOT()
11  sm ← INITSTATEMACHINE(sfg)
12  browser.GOTO(URL)
13  for e ∈ ep do
14    re ← RESOLVEELEMENT(e)
15    robot.ENTERFORMVALUES(re)
16    robot.FIREEVENT(re)
17  CRAWL(s, browser, robot, sm)
18
19 Procedure CRAWL(State ps, EmbeddedBrowser browser, Robot robot, StateMachine sm)
20 begin
21  cs ← sm.GETCURRENTSTATE()
22   $\Delta$ update ← DIFF(ps, cs)
23  f ← ANALYSEFORMS( $\Delta$ update)
24  Set C ← GETCANDIDATECLICKABLES( $\Delta$ update, tags, f)
25  for c ∈ C do
26    SYNCH(c)
27    begin
28      if cs.NOTEXAMINED(c) then
29        robot.ENTERFORMVALUES(c)
30        robot.FIREEVENT(c)
31        cs.EXAMINED(c)
32        dom ← browser.GETDOM()
33        if STATECHANGED(cs.GETDOM(), dom) then
34          xe ← GETXPATHEXPR(c)
35          ns ← sm.ADDSTATE(dom)
36          sm.ADDEDGE(cs, ns, EVENT(c, xe))
37          sm.CHANGETOSTATE(ns)
38          PARTITION(cs)
39          if STATEALLOWEDTOBECRAWLED(ns) then
40            CRAWL(ns)
41            sm.CHANGETOSTATE(ns)
42    end
43 Procedure PARTITION(State cs)
44 begin
45  while SIZEOF(cs.NOTEXAMINEDCLICKABLES()) > 0 do
46    crawlingNode ← CRAWLINGNODE(cs, GETEXACTPATH())
47    DISTRIBUTEPARTITION(crawlingNode)
48

```

0:16

Mesbah et al.

46). The new crawlers are initialized with two parameters, namely, (1) the current state *cs* (2) the execution path from the initial *Index* state to this state. Every new node is distributed to the work queue participating in the concurrent crawling (line 47). When a crawling node is chosen from the work queue, its corresponding *RUN* procedure is called in order to spawn a new crawling thread.

5. TOOL IMPLEMENTATION

We have implemented the crawling concepts in a tool called *CRAWLJAX*. The development of *CRAWLJAX* originally started in 2007. There have been many extension and improvement iterations since the first release in 2008. *CRAWLJAX* has been used by various users and applied to a range of industrial case studies. It is released under the Apache open source license and is available for download. In 2010 alone, the tool was downloaded more than 1000 times. More information about the tool can be found on <http://crawljax.com>.

CRAWLJAX is implemented in Java. We have engineered a variety of software libraries and web tools to build and run *CRAWLJAX*. Here we briefly mention the main modules and libraries.

The embedded browser interface supports three browsers currently (IE, Chrome, Firefox) and has been implemented on top of the Selenium 2.0 (WebDriver) APIs.⁷ The *state-flow graph* is based on the JGraphT⁸ library.

CRAWLJAX has a *Plugin*-based architecture. There are various extension points for different phases of the crawling process. The main interface is *Plugin*, which is extended by the various types of plugin available. Each plugin interface serves as an extension point that is called in a different phase of the crawling execution, e.g., *preCrawlingPlugin* runs before the crawling starts, *OnNewStatePlugin* runs when a new state is found during crawling, *PostCrawlingPlugin* runs after the crawling is finished. More details of the plugin extension points can be found on the project homepage.⁹ There is a growing list of plugins available for *CRAWLJAX*,¹⁰ examples of which include a static mirror generator, a test suite generator, a crawl overview generator for visualization of the crawled states, a proxy to intercept communication between client/server while crawling, and a cross-browser compatibility tester.

Through an API (*CrawljaxConfiguration*), the user is able to configure many crawling options such as the elements that should be examined (e.g., clicked on) during crawling, elements that should be ignored (e.g., logout), crawling depth and time, the maximum number of states to examine, the state comparison method, the plugins to be used, and the number of desired browsers that should be used during crawling.

6. EVALUATION

Since 2008, we and others have used *CRAWLJAX* for a series of crawling tasks on different types of systems. In this section, we provide an empirical assessment of some of the key properties of our crawling technique. In particular, we address the *accuracy* (are the results correct?), *scalability* (can we deal with realistic sites?), and *performance*, focusing in particular on the performance gains resulting from concurrent crawling.

We first present our findings concerning accuracy and scalability, for which we study six systems, described next (Section 6.1). For analyzing the performance gains from concurrent crawling, we apply *CRAWLJAX* to Google's *ADSENSE* application (Section 6.5).

⁷ <http://code.google.com/p/selenium/wiki/GettingStarted>

⁸ <http://jgraph.t.sourceforge.net>

⁹ <http://crawljax.com/documentation/writing-plugins/>

¹⁰ <http://crawljax.com/plugins/>

Crawling AJAX-based Web Applications through Dynamic Analysis of User Interface State Changes0:17

Table I: Experimental benchmarks and examples of their clickable elements.

Case	AJAX site	Sample Clickable Elements
C1	spci.st.ewi.tudelft.nl/demo/aowe/	<pre>testing span 2 2nd link Topics of Interest</pre>
C2	PETSTORE	<pre> Hairy Cat</pre>
C3	www.4launch.nl	<pre><div onclick="setPrefCookies('Gaming', 'DESTROY', 'DESTROY'); loadHoofdCatsTree('Gaming', 1, '')">Gaming</div> <td onclick="open_url(..producteninfo.php?productid= 037631',..)">Harddisk Skin</td></pre>
C4	www.blindtextgenerator.com	<pre><input type="radio" value="7" name="radioTextname" class="js-textname iradio" id="idRadioTextname-EN-li-european"/> </pre>
C5	site.snc.tudelft.nl	<pre><div class="itemtitlelevel1 itemtitle" id="menuitem.189.e">organisatie</div> ... booties</pre>
C6	www.gucci.com	<pre><div id="thumbnail.7" class="thumbnail highlight"></div> <div class="darkening">...</div></pre>

6.1. Subject Systems

In order to assess the accuracy (Section 6.3) and scalability (Section 6.4), we study the six systems C1–C6 listed in Table I. For each case, we show the site under study, as well as a selection of typical clickable elements. We selected these sites because they adopt AJAX to change the state of the application, using JAVASCRIPT, assigning events to HTML elements, asynchronously retrieving delta updates from the server, and performing partial updates on the DOM-tree.

The first site C1 in our case study is an AJAX test site developed internally by our group using the jQuery AJAX library. Although the site is small, it is a case where we are in full control of the AJAX features used, allowing us to introduce different types of dynamically set clickables as shown in Figure 1 and Table I.

Our second case, C2, is Sun's Ajaxified PETSTORE 2.0¹¹ which is built on Java ServerFaces and the Dojo AJAX toolkit. This open-source web application is designed to illustrate how the Java EE Platform can be used to develop an AJAX-enabled Web 2.0 application and adopts many advanced rich AJAX components.

The other four cases are all real-world external public AJAX applications. Thus, we have no access to their source-code. C4 is an AJAX-based application that can function as a tool for comparing the visual impression of different typefaces. C3 (online shop), C5 (sport center), and C6 (Gucci) are all single-page commercial applications with numerous clickables and dynamic states.

¹¹ <http://java.sun.com/developer/releases/petstore/>

Table II: Results of running CRAWLJAX on 6 AJAX applications.

Case	DOM string size (byte)	Candidate Clickables	Detected Clickables	Detected States	Crawl Time (s)	Depth	Tags
C1	4590	540	16	16	14	3	A, DIV, SPAN, IMG
C2	24636	1813	33	34	26	2	A, IMG
C3	262505	150	148	148	498	1	A
		19247	1101	1071	5012	2	A, TD
C4	40282	3808	55	56	77	2	A, DIV, INPUT, IMG
C5	165411	267	267	145	806	1	A
		32365	1554	1234	6436	2	A, DIV
C6	134404	6972	83	79	701	1	A, DIV

6.2. Applying CRAWLJAX

The results of applying CRAWLJAX to C1–C6 are displayed in Table II. The table lists key characteristics of the sites under study, such as the average DOM size and the total number of candidate clickables. Furthermore, it lists the key configuration parameters set, most notably the tags used to identify candidate clickables, and the maximum crawling depth.

The performance measurements were obtained on a laptop with Intel Pentium M 765 processor 1.73GHz, with 1GB RAM and Windows XP.

6.3. Accuracy

6.3.1. Experimental Setup. Assessing the correctness of the crawling process is challenging for two reasons. First, there is no strict notion of “correctness” with respect to state equivalence. The state comparison operator part of our algorithm (see Section 3.4) can be implemented in different ways: the more states it considers equal, the smaller and the more abstract the resulting state-flow graph is. The desirable level of abstraction depends on the intended use of the crawler (regression testing, program comprehension, security testing, to name a few) and the characteristics of the system that is being crawled.

Second, no other crawlers for AJAX are available, making it impossible to compare our results to a “gold standard”. Consequently, an assessment in terms of *precision* (percentage of correct states) and *recall* (percentage of states recovered) is impossible to give.

To address these concerns, we proceed as follows. For the cases where we have full control, C1 and C2, we inject specific clickable elements:

- For C1, 16 elements were injected, out of which 10 were on the top-level index page. Furthermore, to evaluate the state comparison procedure, we intentionally introduced a number of identical (clone) states.
- For C2, we focused on two product categories, CATS and DOGS, from the five available categories. We annotated 36 elements (product items) by modifying the JAVASCRIPT method which turns the items retrieved from the server into clickables on the interface.

Subsequently, we manually create a reference model, to which we compare the derived state-flow graph.

Crawling AJAX-based Web Applications through Dynamic Analysis of User Interface State Changes 0:19

To assess the four external sites C3–C6, we inspect a selection of the states. For each site, we randomly select 10 clickables in advance, by noting their tag names, attributes, and XPath expressions. After crawling of each site, we check the presence of these 10 elements among the list of detected clickables.

In order to do the manual inspection of the results, we run CRAWLJAX with the *Mirror* plugin enabled. This post-crawling plugin creates a static mirror based on the derived state-flow graph, by writing all DOM states to file, and replacing edges with appropriate hyperlinks.

6.3.2. Findings. Our results are as follows:

- For C1, all 16 expected clickables were correctly identified, leading to a precision and recall of 100% for this case. Furthermore, the clone states introduced were correctly identified as such.
- For C2, 33 elements were detected correctly from the annotated 36. The three element that were not detected turn out to be invisible elements requiring multiple clicks on a scroll bar to appear. Since our default implementation avoids clicking the same element multiple times (see Section 3.5), these invisible elements cannot become visible. Hence they cannot be clicked in order to produce the required state change when the default settings are used. Note that multiple events on the same element is an option supported in the latest version of CRAWLJAX.
- For C3–C6, 38 out of the $4 \times 10 = 40$, corresponding to 95% of the states were correctly identified. The reasons for not creating the missing two states is similar to the C2-case: the automatically derived navigational flow did not permit reaching the two elements that had to be clicked in order to generate the required states.

Based on these findings, we conclude that (1) states detected by CRAWLJAX are correct; (2) duplicate states are correctly identified as such; but that (3) not all states are necessarily reached.

6.4. Scalability

6.4.1. Experimental Setup. In order to obtain an understanding of the scalability of our approach, we measure the time needed to crawl, as well as a number of site characteristics that will affect the time needed. We expect the crawling performance to be directly proportional to the input size, which is composed of (1) the average DOM string size, (2) number of candidate elements, and (3) number of detected clickables and states, which are the characteristics that we measure for the six cases.

To test the capability of our method in crawling real sites and coping with unknown environments, we run CRAWLJAX on four external cases C3–C6. We run CRAWLJAX with depth level 2 on C3 and C5 each having a huge state space to examine the scalability of our approach in analyzing tens of thousands of candidate clickables and finding clickables.

6.4.2. Findings. Concerning the time needed to crawl the internal sites, we see that it takes CRAWLJAX 14 and 26 seconds to crawl C1 and C2 respectively. The average DOM size in C2 is 5 times and the number of candidate elements is 3 times higher.

In addition to this increase in DOM size and in the number of candidate elements, the C2 site does not support the browser's built-in Back method. Thus, as discussed in Section 3.6, for every state change on the browser CRAWLJAX has to reload the application and click through to the previous state to go further. This reloading and clicking through naturally has a negative effect on the performance.

Note that the performance is also dependent on the CPU and memory of the machine CRAWLJAX is running on, as well as the speed of the server and network properties

0:20

Mesbah et al.

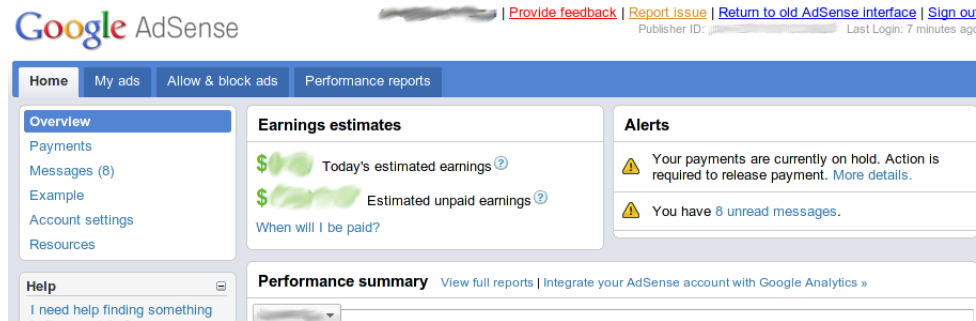

Fig. 8: Google ADSENSE.

of the case site. C6, for instance, is slow in reloading and retrieving updates from its server, which increases the performance measurement numbers in our experiment.

CRAWLJAX was able to run smoothly on the external sites. Except a few minor adjustments (see Section 7) we did not witness any difficulties. C3 with depth level 2 was crawled successfully in 83 minutes resulting in 19247 examined candidate elements, 1101 detected clickables, and 1071 detected states. For C5, CRAWLJAX was able to finish the crawl process in 107 minutes on 32365 candidate elements, resulting in 1554 detected clickables and 1234 states. As expected, in both cases, increasing the depth level from 1 to 2 expands the state space greatly.

Section 6.5 presents our case study conducted on Google ADSENSE, which shows the scalability of the approach on a real-world industrial web application.

6.5. Concurrent Crawling

In our final experiment, the main goal is to assess the influence of the concurrent crawling algorithm on the crawling runtime.

6.5.1. Experimental Object. Our experimental object for this study is *Google ADSENSE*¹², an AJAX application developed by *Google*, which empowers online publishers to earn revenue by displaying relevant ads on their web content. The ADSENSE interface is built using GWT (Google Web Toolkit) components and is written in Java.

Figure 8 shows the index page of ADSENSE. On the top, there are four main tabs (Home, My ads, Allow & block ads, Performance reports). On the top-left side, there is a box holding the anchors for the current selected tab. Underneath the left-menu box, there is a box holding links to help related pages. On the right of the left-menu we can see the main contents, which are loaded by AJAX calls.

6.5.2. Experimental Design. Our research questions can be presented as follows:

RQ1. Does our concurrent crawling approach positively influence the performance?

RQ2. Is there a limit on the number of browsers that can be used to reduce the runtime?

Based on these two research questions we formulate our two null hypotheses as follows:

H1₀. The availability of more browsers does not impact the time needed to crawl a given AJAX application.

¹² <https://www.google.com/adsense/>

Crawling AJAX-based Web Applications through Dynamic Analysis of User Interface State Changes0:21

$H2_0$. There is no limit on the number of browsers that can be added to reduce the runtime.

The alternative hypotheses that we use in the experiment are the following:

$H1$. The availability of more browsers reduces the time needed to crawl a given AJAX application.

$H2$. There is a limit on the number of browsers that can be added to reduce the runtime.

Infrastructure To derive our experimental data we use the *Google* infrastructure, which offers the possibility to run our experiments either on a local workstation or on a distributed testing cluster.

On the distributed testing cluster, the number of cores varies between clusters. Newer clusters are supplied with 6 or 8 core CPU's, while older clusters include 2 or 4 cores. The job-distributor ensures a minimum of 2 Gb of memory per job at minimum. The cluster is shared between all development teams, so our experiment data were gathered while other teams were also using the cluster. To prevent starvation on the distributed testing cluster, a maximum runtime of one hour is specified, i.e., any test running longer than an hour is killed automatically.

To achieve a repeatable experiment, we initiate a new *AdSense* front-end with a clean database server for every experimental test. The test-data is loaded into the database during the initialization phase of the *AdSense* front-end.

Tool Configuration To crawl ADSENSE, we configured CRAWLJAX 2.0 to click on all anchor-tags and fill in form inputs with custom data.

To inform the user that the interface is being updated, ADSENSE displays a loading icon. While crawling, to determine whether the interface was finished with loading the content after each fired event, CRAWLJAX analyzed the DOM-tree to check for this icon.

Due to the infrastructure we were restricted to use Linux as our operating system and we chose Firefox 3.5 as our embedded browser.

Variables and Analysis The *independent variable* in our experiment is the number of browsers used for crawling. We use the same crawl configuration for all the experiments. The only property that changes is the number of browsers used during crawling: 1-10.

The *dependent variable* that we measure is the time needed to crawl the given crawl specification, calculated from the start of the crawling until the (last) browser finishes. To compare, we also measure the actual number of examined clickables, crawled states, edges, and paths.

We run every experiment multiple times and take the average of the runtime. On the distributed cluster all resources are shared. Hence, to get reliable data we executed every experiment 300 times.

Since we have 10 independent samples of data with 2953 (see Table III) data points, we use the One-Way ANOVA statistical method to test the first hypothesis ($H1_0$). Levene's test is used for checking the homogeneity of variances. Welch and Brown-Forsythe are used as tests of equality of means [Maxwell and Delaney 2004].

If $H1$ turns out to be true, we proceed with our second hypothesis. To test $H2_0$, we need to compare the categories to find out which are responsible for runtime differences. Thus, we use the Post Hoc Tukey test if the population variances are equal, or

0:22

Mesbah et al.

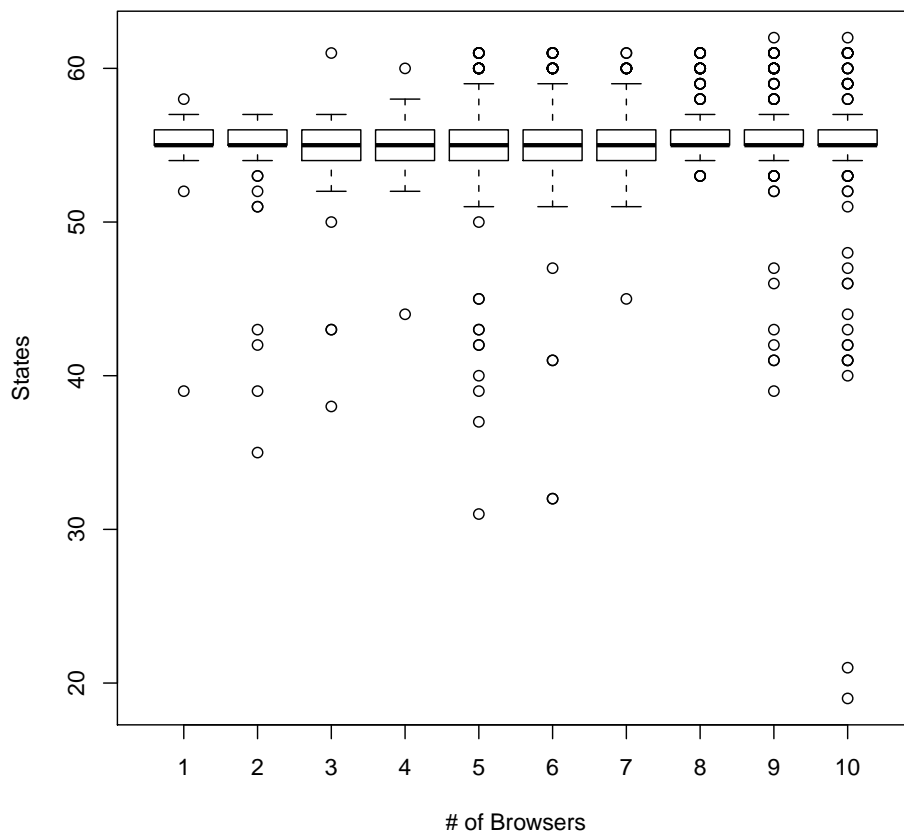

Fig. 9: Boxplots of detected states versus the number of browsers. Distributed setting (300 measurements for each category of browsers).

the Games-Howell test if that does not turn out to be the case. We use SPSS¹³ for the statistical analysis and R¹⁴ for plotting the graphs.

6.5.3. Results and Evaluation. We present our data and analysis on the data from the distributed infrastructure. We obtained similar results with different configurations. Our experimental data can be found on the following link.¹⁵

Figures 9-11 depict boxplots of the detected states, detected edges, and runtime (minutes) respectively versus the number of browsers used during crawling, on the distributed infrastructure. The number of detected states and edges is constant, which means our multi-browser crawling and state exploration is stable.

¹³ <http://www.spss.com>

¹⁴ <http://www.r-project.org>

¹⁵ <http://tinyurl.com/3d5km3b>

Crawling AJAX-based Web Applications through Dynamic Analysis of User Interface State Changes0:23

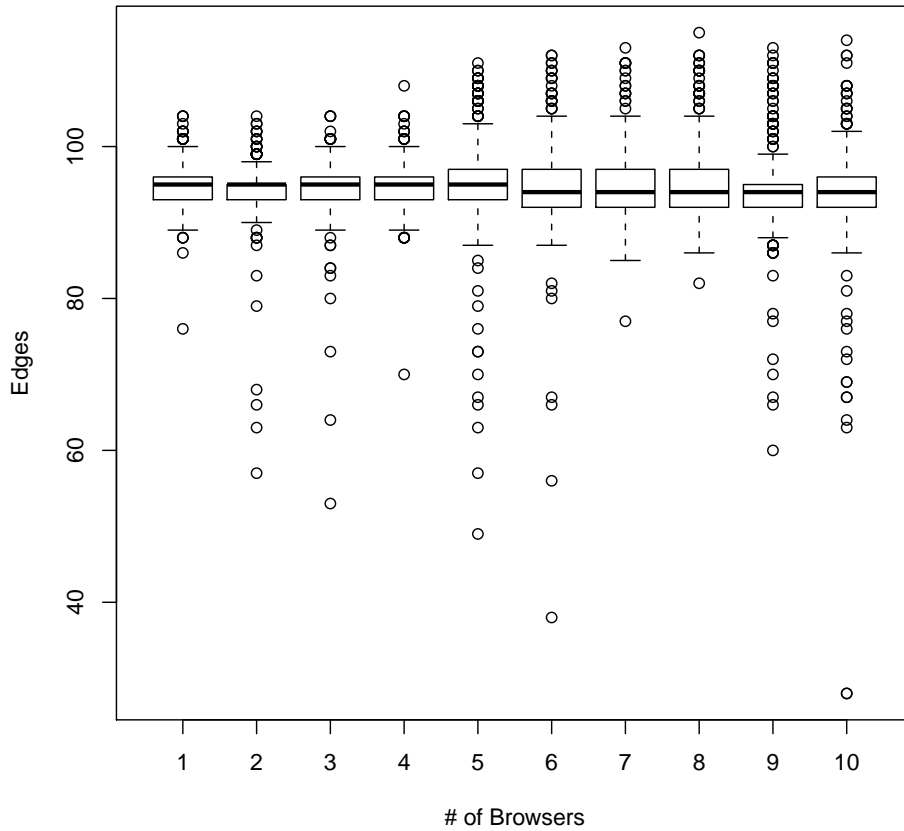

Fig. 10: Boxplots of detected edges versus the number of browsers. Distributed setting (300 measurements for each category of browsers).

Table III: Descriptive statistics of the runtime (in minutes) for the 10 categories of browsers. * 95% Confidence Interval for Mean.

	N	Mean	Std. Dev.	Std. Err.	Lower Bound*	Upper Bound*	Min	Max
1	2953	7.4871	3.70372	.06816	7.3535	7.6207	2.33	22.15
2	299	5.4721	1.14160	.06602	5.3422	5.6020	2.33	10.55
3	295	5.5521	1.26716	.07378	5.4069	5.6973	3.38	11.83
4	297	5.6404	1.11101	.06447	5.5135	5.7673	3.78	11.12
5	291	5.6744	1.15004	.06742	5.5417	5.8070	3.69	10.75
6	290	5.6920	.99718	.05856	5.5767	5.8072	4.20	11.01
7	294	5.9806	1.05696	.06164	5.8593	6.1020	4.13	10.72
8	297	6.2338	1.03936	.06031	6.1151	6.3525	4.74	10.32
9	292	7.4651	1.04823	.06134	7.3444	7.5858	5.35	10.56
10	299	9.9243	1.28598	.07437	9.7779	10.0707	7.05	13.37
Total	299	17.0613	2.31540	.13390	16.7978	17.3249	10.17	22.15

Figure 11 shows that there is a decrease in the runtime when the number of browsers is increased. Table III presents the descriptive statistics of the runtime for the 10 categories of browsers.

0:24

Mesbah et al.

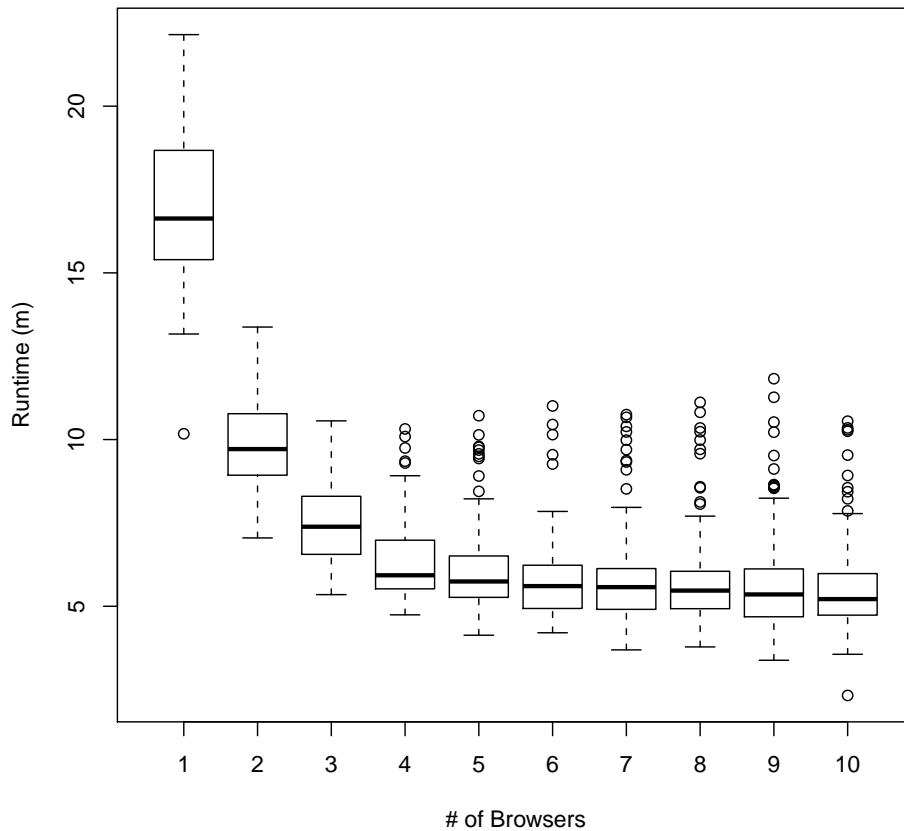

Fig. 11: Boxplots of runtime versus the number of browsers. Distributed setting (300 measurements for each category of browsers).

Table IV shows the main ANOVA result. The significance value comparing the groups is $< .05$. The significance value for homogeneity of variances, as shown in Table V, is $< .05$, which means the variances are significantly different. The Welch and Brown-Forsythe are both 0, so we can reject the first null hypothesis. Thus, we can conclude that our concurrent crawling approach positively influences the performance.

To test for the second hypothesis, we need to compare the groups to find out if the differences between them is significant. Table VI shows our post hoc test results. a * means that the difference in runtime is significant. It is evident that there is a limit on the number of browsers that can significantly decrease the runtime. The optimal number for our ADSENSE study is 5 browsers. By increasing the number of browsers from 1 to 5, we can achieve a decrease of up to **65%** in runtime. Increasing the number of browsers beyond 5 has no significant influence on the runtime in our current impementation.

Crawling AJAX-based Web Applications through Dynamic Analysis of User Interface State Changes0:25

Table IV: One-way ANOVA.

	Sum of Squares	df	Mean Square	F	Sig.
Between Groups	35540.225	9	3948.914	2345.919	000
Within Groups	4953.987	2943	1.683		
Total	40494.212	2952			

Table V: Tests for Homogeneity of Variances and Equality of Means.

Method	Statistic	df1	df2	Sig.
Levene	55.884	9	2943	0.000
Welch	1060.017	9	1198.048	0.000
Brown-Forsythe	2355.528	9	1914.845	0.000

Table VI: Post Hoc Games-Howell multiple comparisons. * indicates the mean difference is significant at the 0.05 level.

	1	2	3	4	5	6	7	8	9	10
1	-	*	*	*	*	*	*	*	*	*
2	*	-	*	*	*	*	*	*	*	*
3	*	*	-	*	*	*	*	*	*	*
4	*	*	*	-	*	*	*	*	*	*
5	*	*	*	*	-	*	*	*	*	*
6	*	*	*	*	*	-	*	*	*	*
7	*	*	*	*	*	*	-	*	*	*
8	*	*	*	*	*	*	*	-	*	*
9	*	*	*	*	*	*	*	*	-	*
10	*	*	*	*	*	*	*	*	*	-

6.6. Threats to Validity

As far as the repeatability of the studies is concerned, CRAWLJAX is open source and publicly available for download. The experimental applications in Section 6.1 are composed of open source and public domain websites. In the concurrent crawling experiment (Section 6.5), the study was done at Google using Google's ADSENSE, which is also publicly accessible. More case studies are required to generalize the findings on correctness and scalability. One concern with using public domain web applications as benchmarks is that they can change and evolve over time, making the results of the study irreproducible in the future.

7. DISCUSSION

7.1. Detecting DOM Changes

An interesting observation in C2 in the beginning of the experiment was that every examined candidate element was detected as a clickable. Further investigation revealed that this phenomenon was caused by a piece of JAVASCRIPT code (banner), which constantly changed the DOM-tree with textual notifications. Hence, every time a DOM comparison was done, a change was detected. We had to use a higher similarity threshold so that the textual changes caused by the banner were not seen as a relevant state change for detecting clickables. In CRAWLJAX, it is also possible to ignore certain parts of the DOM-tree through, for instance, regular expressions that capture the recurring patterns. How the notion of a dynamic *state change* is defined can poten-

0:26

Mesbah et al.

tially influence the crawling behaviour. The automatic crawler ignores subtle changes in the DOM that we believe are not of significant importance (such as case sensitivity and timestamps). We also provide the user with different mechanisms to define their own notion of state similarity. Push-based techniques such as Comet [Russell 2006] in which data is constantly pushed from the server could also cause state comparison challenges. Such push-based updates are usually confined to a specific part of the DOM tree and hence can be controlled using custom DOM change filters.

7.2. Back and forward tracking

Because of side effects of back-end state changes, there is no guarantee that we reach the exact same state when we traverse a click path a second time. This non-determinism characteristic is inherent in dynamic web applications. Our crawler uses the notion of state similarity, thus as long as the revisited state is similar to the state visited before, the crawling process continues without side-effects. In our experiments, we did not encounter any problems with this non-deterministic behaviour.

When the crawling approach is used for testing web applications, one way to ensure that a state revisited is the same as the state previously visited (e.g., for regression testing [Roest et al. 2010]), is by bringing the server-side state to the previous state as well, which could be challenging. More research is needed to adopt ways of synchronizing the client and server side state during testing.

Cookies can also cause some problems in crawling AJAX applications. C3 uses Cookies to store the state of the application on the client. With Cookies enabled, when CRAWLJAX reloads the application to navigate to a previous state, the application does not start in the expected initial state. In this case, we had to disable Cookies to perform a correct crawling process. The new features of HTML5 such as web storage [Hickson 2011] could possibly cause the same problems by making parts of the client-side state persistent between backtracking sessions. It would be interesting future work to explore ways to get around these issues.

7.3. State Space

The set of found states and the inferred state machine is not complete i.e., CRAWLJAX creates an instance of the state machine of the AJAX application but not necessarily *the* instance. Any crawler can only crawl and index a snapshot instance of a dynamic web application in a given point of time. The order in which clickables are chosen could generate different states. Even executing the same clickable twice from an state could theoretically produce two different DOM states depending on, for instance, server-side factors.

The number of possible states in the state space of almost any realistic web application is huge and can cause the well-know *state explosion problem* [Valmari 1998]. Just as a traditional web crawler, CRAWLJAX provides the user with a set of configurable options to constrain the state space such as the maximum search depth level, the similarity threshold, maximum number of states per domain, maximum crawling time, and the option of ignoring external links (i.e., different domains) and links that match some predefined set of regular expressions, e.g., mail:*, *.ps, *.pdf.

The current implementation of CRAWLJAX keeps the DOM states in the memory. As an optimization step, next to the multi-browser crawling, we intend to abstract and serialize the DOM state into the file system and only keep a reference in the memory. This saves much space in the memory and enables us to handle much more states. With a cache mechanism, the essential states for analysis can be kept in the memory while the other ones can be retrieved from the file system when needed in a later stage.

Crawling AJAX-based Web Applications through Dynamic Analysis of User Interface State Changes0:27

7.4. DOM Settling

Determining when a DOM is fully loaded into the browser after a request or an event is a very difficult task. Partially loaded DOM states can adversely influence the state exploration accuracy during crawling. The asynchronous nature of AJAX calls and the dynamic DOM updates make the problem even more challenging to handle. Since the major browsers currently do not provide APIs to determine when a DOM-tree is fully loaded, we wait a specific amount of time after each event or page reload. This waiting time can be adjusted by the user through the CRAWLJAX configuration API. By choosing a high enough waiting time, we can be certain that the DOM is fully settled in the browser. As a side effect, a too high waiting period, can make the crawling process slow.

An alternative way that is more reliable is when the web application provides a completion flag in the form of a DOM element either visible or invisible to the end user. Before continuing with its crawling operations, CRAWLJAX can be configured to wait for that specific DOM flag to appear after each state transition. This flag-based waiting approach is in fact what we used during our experiments on ADSENSE.

7.5. Applications of CRAWLJAX

As mentioned in the introduction, we believe that the crawling and generating capabilities of our approach have many applications for modern web applications.

We believe that the crawling techniques that are part of our solution can serve as a starting point and be adopted by general search engines to expose the hidden-web content induced by JAVASCRIPT in general and AJAX in particular.

In their proposal for making AJAX applications crawlable,¹⁶ Google proposes using URLs containing a special hash fragment, i.e., #!, for identifying dynamic content. Google then uses this hash fragment to send a request to the server. The server has to treat this request in a special way and send a HTML snapshot of the dynamic content, which is then processed by Google's crawler. In the same proposal, they suggest using CRAWLJAX for creating a static snapshot for this purpose. Web developers can use the model inferred by CRAWLJAX to automatically generate a static HTML snapshot of their dynamic content, which then can be served to Google for indexing.

The ability to automatically detect and exercise the executable elements of an AJAX site and navigate between the various dynamic states gives us a powerful web analysis and test automation mechanism. In the recent past, we have applied CRAWLJAX in the following web testing domains: (1) invariant-based testing of AJAX user interfaces [Mesbah and van Deursen 2009], (2) spotting security violations in web widget interactions [Bezemer et al. 2009] (3) regression testing of dynamic and non-deterministic web interfaces [Roest et al. 2010], and (4) automated cross-browser compatibility testing [Mesbah and Prasad 2011].

8. RELATED WORK

Web crawlers, also known as web spiders and (ro)bots, have been studied since the advent of the web itself [Pinkerton 1994; Heydon and Najork 1999; Cho et al. 1998; Brin and Page 1998; Burner 1997].

More recently, there has been extensive research, on the hidden-web behind forms [Raghavan and Garcia-Molina 2001; de Carvalho and Silva 2004; Lage et al. 2004; Ntoulas et al. 2005; Barbosa and Freire 2007; Dasgupta et al. 2007; Madhavan et al. 2008]. The main focus in this research area is to detect ways of accessing the web content behind data entry points.

¹⁶ <http://code.google.com/web/ajaxcrawling/docs/getting-started.html>

0:28

Mesbah et al.

On the contrary, the hidden-web induced as a result of client-side scripting in general and AJAX in particular has gained very little attention so far.

Alvares *et al.* [2004; 2006] discuss some challenges of crawling hidden content generated with JAVASCRIPT, but focus on hypertext links.

To the best of our knowledge, our initial work on CRAWLJAX [Mesbah et al. 2008] in 2008 was the first academic research work proposing a solution to the problem of crawling AJAX, in the form of algorithms and an open source tool that automatically crawls and creates a finite state-machine of the states and transitions.

In 2009, Duda et al. [2009] discussed how AJAX states could be indexed. The authors present a crawling and indexing algorithm. Their approach also builds finite state models of AJAX applications, however, there is no accompanying tool available for comparison. The main difference between their algorithm and ours seems to be in the way clickable elements are detected, which is through JAVASCRIPT analysis.

The work of Memon *et al.* [2001; 2003] on GUI Ripping for testing purposes is related to our work in terms of how they reverse engineer an event-flow graph of desktop GUI applications by applying dynamic analysis techniques.

There also exists a large body of knowledge targeting challenges in parallel and distributed computing. Specifically for the web, Cho and Garcia-Molina [2002] discuss the challenges of parallel crawling and propose an architecture for parallel crawling the classical web. Boldi et al. [2004] present the design and implementation of UbiCrawler, a distributed web crawling tool. Note that these works are URL-based and as such not capable of targeting event-based AJAX applications.

9. CONCLUDING REMARKS

Crawling modern AJAX-based web systems requires a different approach than the traditional way of extracting hypertext links from web pages and sending requests to the server.

This paper proposes an automated crawling technique for AJAX-based web applications, which is based on dynamic analysis of the client-side web user interface in embedded browsers. The main contributions of our work are:

- An analysis of the key challenges involved in crawling AJAX-based applications;
- A systematic process and algorithm to drive an AJAX application and infer a state machine from the detected state changes and transitions. Challenges addressed include the identification of clickable elements, the detection of DOM changes, and the construction of the state machine;
- A concurrent multi-browser crawling algorithm to improve the runtime performance;
- The open source tool called CRAWLJAX, which implements the crawling algorithms;
- Two studies, including seven AJAX applications, used to evaluate the effectiveness, correctness, performance, and scalability of the proposed approach.

Although we have been focusing on AJAX in this paper, we believe that the approach could be applied to any DOM-based web application.

The fact that the tool is freely available for download will help to identify exciting case studies. Furthermore, strengthening the tool by extending its functionality, improving the accuracy, performance, and the state explosion algorithms are directions we foresee for future work. We will conduct controlled experiments to systematically analyze and find new ways of optimizing the back tracking algorithm and implementation. Many AJAX applications use hash fragments in URLs nowadays. Investigating how such hash fragments can be utilized during crawling is another interesting direction. Exploring the hidden-web induced by client-site JAVASCRIPT using CRAWLJAX

Crawling AJAX-based Web Applications through Dynamic Analysis of User Interface State Changes0:29

and continuing with automated web analysis and testing are other application domains we will be working on.

REFERENCES

- ALVAREZ, M., PAN, A., RAPOSO, J., AND HIDALGO, J. 2006. Crawling web pages with support for client-side dynamism. In *Advances in Web-Age Information Management*. Lecture Notes in Computer Science Series, vol. 4016. Springer, 252–262.
- ALVAREZ, M., PAN, A., RAPOSO, J., AND VINA, A. 2004. Client-side deep web data extraction. In *CEC-EAST '04: Proceedings of the IEEE International Conference on E-Commerce Technology for Dynamic E-Business*. IEEE Computer Society, 158–161.
- ATTERER, R. AND SCHMIDT, A. 2005. Adding usability to web engineering models and tools. In *Proceedings of the 5th International Conference on Web Engineering (ICWE'05)*. Springer, 36–41.
- BARBOSA, L. AND FREIRE, J. 2007. An adaptive crawler for locating hidden-web entry points. In *WWW '07: Proceedings of the 16th international conference on World Wide Web*. ACM Press, 441–450.
- BEZEMER, C.-P., MESBAH, A., AND VAN DEURSEN, A. 2009. Automated security testing of web widget interactions. In *Proceedings of the 7th joint meeting of the European Software Engineering Conference and the ACM SIGSOFT symposium on the Foundations of Software Engineering (ESEC-FSE'09)*. ACM, 81–91.
- BOLDI, P., CODENOTTI, B., SANTINI, M., AND VIGNA, S. 2004. Ubicrawler: A scalable fully distributed web crawler. *Software: Practice and Experience* 34, 8, 711–726.
- BRIN, S. AND PAGE, L. 1998. The anatomy of a large-scale hypertextual Web search engine. *Comput. Netw. ISDN Syst.* 30, 1-7, 107–117.
- BURNER, M. 1997. Crawling towards eternity: Building an archive of the world wide web. *Web Techniques Magazine* 2, 5, 37–40.
- CHAWATHE, S. S., RAJARAMAN, A., GARCIA-MOLINA, H., AND WIDOM, J. 1996. Change detection in hierarchically structured information. In *SIGMOD '96: Proceedings of the 1996 ACM SIGMOD international conference on Management of data*. ACM Press, 493–504.
- CHO, J. AND GARCIA-MOLINA, H. 2002. Parallel crawlers. In *Proceedings of the 11th international conference on World Wide Web*. ACM, 124–135.
- CHO, J., GARCIA-MOLINA, H., AND PAGE, L. 1998. Efficient crawling through URL ordering. *Computer Networks and ISDN Systems* 30, 1-7, 161–172.
- DASGUPTA, A., GHOSH, A., KUMAR, R., OLSTON, C., PANDEY, S., AND TOMKINS, A. 2007. The discoverability of the web. In *WWW '07: Proceedings of the 16th international conference on World Wide Web*. ACM Press, 421–430.
- DE CARVALHO, A. F. AND SILVA, F. S. 2004. Smartcrawl: a new strategy for the exploration of the hidden web. In *WIDM '04: Proceedings of the 6th annual ACM international workshop on Web information and data management*. ACM Press, 9–15.
- DIJKSTRA, E. W. 1959. A note on two problems in connexion with graphs. *Numerische Mathematik* 1, 1, 269–271.
- DUDA, C., FREY, G., KOSSMANN, D., MATTER, R., AND ZHOU, C. 2009. Ajax crawl: making Ajax applications searchable. In *25th International Conference on Data Engineering (ICDE'09)*. IEEE, 78–89.
- FIELDING, R. AND TAYLOR, R. N. 2002. Principled design of the modern Web architecture. *ACM Trans. Inter. Tech. (TOIT)* 2, 2, 115–150.
- GARAVEL, H., MATEESCU, R., AND SMARANDACHE, I. 2001. Parallel state space construction for model-checking. *Model Checking Software 2007*, 217–234.
- GARRETT, J. February 2005. Ajax: A new approach to web applications. Adaptive path. <http://www.adaptivepath.com/publications/essays/archives/000385.php>.
- HEYDON, A. AND NAJORK, M. 1999. Mercator: A scalable, extensible web crawler. *World Wide Web* 2, 4, 219–229.
- HICKSON, I. 2011. W3C Web Storage. <http://dev.w3.org/html5/webstorage/>.
- LAGE, J. P., DA SILVA, A. S., GOLGHER, P. B., AND LAENDER, A. H. F. 2004. Automatic generation of agents for collecting hidden web pages for data extraction. *Data Knowl. Eng.* 49, 2, 177–196.
- LEVENSHTEIN, V. L. 1996. Binary codes capable of correcting deletions, insertions, and reversals. *Cybernetics and Control Theory* 10, 707–710.
- MADHAVAN, J., KO, D., KOT, L., GANAPATHY, V., RASMUSSEN, A., AND HALEVY, A. 2008. Google's deep web crawl. *Proc. VLDB Endow.* 1, 2, 1241–1252.

0:30

Mesbah et al.

- MAXWELL, S. AND DELANEY, H. 2004. *Designing experiments and analyzing data: A model comparison perspective*. Lawrence Erlbaum.
- MEMON, A., BANERJEE, I., AND NAGARAJAN, A. 2003. GUI ripping: Reverse engineering of graphical user interfaces for testing. In *10th Working Conference on Reverse Engineering (WCRE'03)*. IEEE Computer Society, 260–269.
- MEMON, A., SOFFA, M. L., AND POLLACK, M. E. 2001. Coverage criteria for GUI testing. In *Proceedings ESEC/FSE'01*. ACM Press, 256–267.
- MESBAH, A., BOZDAG, E., AND VAN DEURSEN, A. 2008. Crawling Ajax by inferring user interface state changes. In *Proceedings of the 8th International Conference on Web Engineering (ICWE'08)*. IEEE Computer Society, 122–134.
- MESBAH, A. AND VAN DEURSEN, A. 2007. Migrating multi-page web applications to single-page Ajax interfaces. In *Proc. 11th Eur. Conf. on Sw. Maintenance and Reengineering (CSMR'07)*. IEEE Computer Society, 181–190.
- MESBAH, A. AND PRASAD, M. R. 2011. Automated cross-browser compatibility testing. In *Proceedings of the 33rd ACM/IEEE International Conference on Software Engineering (ICSE'11)*. ACM, 561–570.
- MESBAH, A. AND VAN DEURSEN, A. 2008. A component- and push-based architectural style for Ajax applications. *Journal of Systems and Software* 81, 12, 2194–2209.
- MESBAH, A. AND VAN DEURSEN, A. 2009. Invariant-based automatic testing of Ajax user interfaces. In *Proceedings of the 31st International Conference on Software Engineering (ICSE'09)*. IEEE Computer Society, 210–220.
- NTOULAS, A., ZERFOS, P., AND CHO, J. 2005. Downloading textual hidden web content through keyword queries. In *JCDL '05: Proceedings of the 5th ACM/IEEE-CS joint conference on Digital libraries*. ACM Press, 100–109.
- PINKERTON, B. 1994. Finding what people want: Experiences with the web crawler. In *Proceedings of the Second International World Wide Web Conference*. Vol. 94. 17–20.
- PIXLEY, T. 2000. W3C Document Object Model (DOM) Level 2 Events Specification. <http://www.w3.org/TR/DOM-Level-2-Events/>.
- RAGHAVAN, S. AND GARCIA-MOLINA, H. 2001. Crawling the hidden web. In *VLDB '01: Proceedings of the 27th International Conference on Very Large Data Bases*. Morgan Kaufmann Publishers Inc., 129–138.
- ROEST, D., MESBAH, A., AND VAN DEURSEN, A. 2010. Regression testing Ajax applications: Coping with dynamism. In *Proceedings of the 3rd International Conference on Software Testing, Verification and Validation (ICST'10)*. IEEE Computer Society, 128–136.
- RUSSELL, A. 2006. Comet: Low latency data for the browser. <http://alex.dojotoolkit.org/?p=545>.
- VALMARI, A. 1998. The state explosion problem. In *LNCS: Lectures on Petri Nets I, Basic Models, Advances in Petri Nets*. Springer-Verlag, 429–528.

Received 2010; revised ; accepted

TUD-SERG-2011-033
ISSN 1872-5392

