



AALBORG UNIVERSITY
DENMARK

Aalborg Universitet

Critical Review of PV Grid-Tied Inverters

Santhoshi, B. Kavya; Sundaram, K. Mohana; Padmanaban, Sanjeevikumar; Holm-Nielsen, Jens Bo; Prabhakaran, K. K.

Published in:
Energies

DOI (link to publication from Publisher):
[10.3390/en12101921](https://doi.org/10.3390/en12101921)

Creative Commons License
CC BY 4.0

Publication date:
2019

Document Version
Publisher's PDF, also known as Version of record

[Link to publication from Aalborg University](#)

Citation for published version (APA):
Santhoshi, B. K., Sundaram, K. M., Padmanaban, S., Holm-Nielsen, J. B., & Prabhakaran, K. K. (2019). Critical Review of PV Grid-Tied Inverters. *Energies*, 12(10), [1921]. <https://doi.org/10.3390/en12101921>

General rights

Copyright and moral rights for the publications made accessible in the public portal are retained by the authors and/or other copyright owners and it is a condition of accessing publications that users recognise and abide by the legal requirements associated with these rights.

- Users may download and print one copy of any publication from the public portal for the purpose of private study or research.
- You may not further distribute the material or use it for any profit-making activity or commercial gain
- You may freely distribute the URL identifying the publication in the public portal -

Take down policy

If you believe that this document breaches copyright please contact us at vbn@aub.aau.dk providing details, and we will remove access to the work immediately and investigate your claim.

Review

Critical Review of PV Grid-Tied Inverters

B. Kavya Santhoshi ¹, K. Mohana Sundaram ^{1,*} , Sanjeevikumar Padmanaban ² ,
Jens Bo Holm-Nielsen ² and Prabhakaran K. K. ³ 

¹ Department of Electrical and Electronics, Vel Tech Multi Tech, Chennai 600062, Tamil Nadu, India; kavyabe2010@gmail.com

² Center for Bioenergy and Green Engineering, Aalborg University, 6700 Esbjerg, Denmark; san@et.aau.dk (S.P.); jhn@et.aau.dk (J.B.H.-N.)

³ Center for System Design, National Institute of Technology Karnataka, Surathkal 575025, India; k7prabhakaran@gmail.com

* Correspondence: kumohanasundaram@gmail.com; Tel.: +91-960-004-7399

Received: 12 March 2019; Accepted: 15 May 2019; Published: 20 May 2019



Abstract: Solar Photovoltaic (PV) systems have been in use predominantly since the last decade. Inverter fed PV grid topologies are being used prominently to meet power requirements and to insert renewable forms of energy into power grids. At present, coping with growing electricity demands is a major challenge. This paper presents a detailed review of topological advancements in PV-Grid Tied Inverters along with the advantages, disadvantages and main features of each. The different types of inverters used in the literature in this context are presented. Reactive power is one of the ancillary services provided by PV. It is recommended that reactive power from the inverter to grid be injected for reactive power compensation in localized networks. This practice is being implemented in many countries, and researchers have been trying to find an optimal way of injecting reactive power into grids considering grid codes and requirements. Keeping in mind the importance of grid codes and standards, a review of grid integration, the popular configurations available in literature, Synchronization methods and standards is presented, citing the key features of each kind. For successful integration with a grid, coordination between the support devices used for reactive power compensation and their optimal reactive power capacity is important for stability in grid power. Hence, the most important and recommended intelligent algorithms for the optimization and proper coordination are peer reviewed and presented. Thus, an overview of Solar PV energy-fed inverters connected to the grid is presented in this paper, which can serve as a guide for researchers and policymakers.

Keywords: ancillary services; grid; inverter; PV; reactive power; solar; Quasi-Z source inverter (QZSI); Y source inverter (YSI)

1. Introduction

Grid-tied photovoltaic systems are power-generating systems that are connected with grids. Solar PV energy that is generated must be processed with the help of a grid-connected inverter before putting it to use. This inverter is present between the solar PV arrangement and the utility grid; it could be a single unit or a collection of small inverters attached to the individual PV units. Due to the lowered cost of power electronic devices and advancements in renewable energy technology, there is significant encouragement for the power industry to utilize PV solar energy and to attach it to a medium or low voltage distribution grid. The renewable electrical energy market has experienced an extraordinary increase in scope in recent years. Its main catalyst in 2016 was solar photovoltaics, which are boosting the capacity of renewables all over the world. Due to reductions in costs, solar and wind energy are playing an increasingly important role and are proving to be competitive with fossil fuels in many

countries. Two-thirds of overall electricity additions in 2016 were from renewable sources of energy [1]. According to the International Energy Agency, solar is leading in additions compared to wind and hydropower. The statistics of net additions and retirements in electricity capacity are shown in Figure 1.

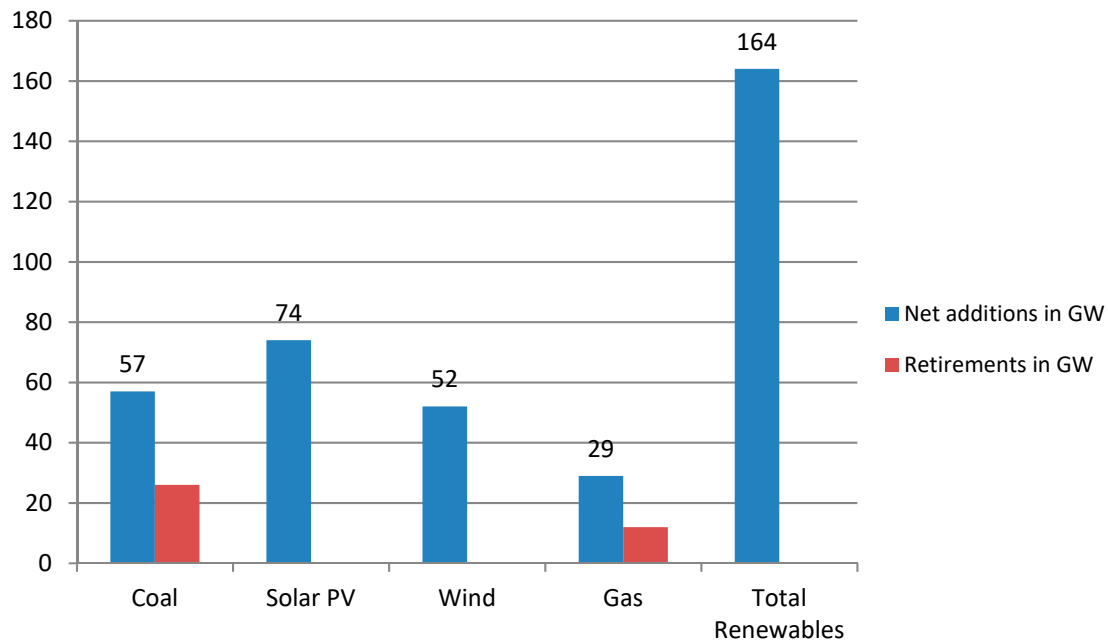

Figure 1. Net additions and retirements of Electricity capacity in 2016. Reproduced from [1], International Energy Agency: 2017.

From [2], it is noted that Solar PV has dominated all other forms of electricity production. Its capacity comprises almost 600 Giga Watt (GW) more than all other forms of energy combined. Thus, with this increasing trend in use of Solar PVs, it becomes even more important to study the obstacles faced in extracting energy from solar PV systems and then exporting it or integrating it with the grid. The primary factors to be borne in mind while integrating PV solar energy with the grid are:

1. Reducing the cost during power conversion stage
2. Improving the reliability of the converter in use
3. Reducing the harmonics in the output current obtained
4. Reducing the number of switches/components used in grid integration
5. Ensuring continuity in supply by providing back up power for PVs.
6. Controlling the real and reactive power
7. Maintaining a constant direct current (DC) link voltage via a suitable control scheme
8. Detecting the maximum power point of PV panel using Maximum Power Point Tracking (MPPT) techniques.

Henceforth, a detailed review is done, keeping in mind the current trend and effectiveness of energy produced, and the simplicity of its integration with the grid. This paper is organized as follows:

Section 2: Ancillary services in electric market

Section 3: PV-grid inverters—A summary of different topologies

Section 4: A Review on Intelligent Algorithms and Optimization Techniques

Section 5: Conclusion & future scope

Section 6: References

2. Ancillary Services in Electric Market

2.1. Definitions of Ancillary Service

In this section, a brief introduction to ancillary services has been given with standard definitions from the literature. An insight to Reactive Power (Q) being an ancillary service is provided. In order to understand the concept of ancillary services, a few definitions from the literature have been listed here.

- * As per International Electro technical Commission (IEC) 60050-617, ancillary services are “services necessary for the operation of an electric power system provided by the system operator and/or by power system users” [3].
- * According to the Union of Electric Industry EURELECTRIC: “Ancillary Services are those services provided by generation, transmission and control equipment which are necessary to support the transmission of electric power from producer to purchaser. These services are required to ensure that the System Operator meets its responsibilities in relation to the safe, secure and reliable operation of the interconnected power system. The services include both mandatory services and services subject to competition” [3].
- * Federal Energy Regulatory Commission (FERC) defined ancillary services as those “necessary to support the transmission of electric power from seller to purchaser given the obligations of control areas and transmitting utilities within those control areas to maintain reliable operations of the interconnected transmission system” [4].

2.2. Popular Ancillary Services in Electric Power Market

Figure 2 shows some popular ancillary services in electric power market. They are:

1. Q Management: Q Management is a service that is unbundled to both suppliers and consumers. A system operator can control this service but the control is limited to local control area. Q management is the same ancillary service as voltage control. Voltage control is done to balance voltages in accordance with the prescribed limits during different time slots of power transmission. Q injection and absorption leads to system stability and yields protection against unforeseen events that may cause voltage breakdown. Hence, reactive-power must be made available to meet the expected demand and serve as a reserve margin during emergencies.
2. Real power (P) loss replacement: P loss is the variation in P generated and delivered. Due to resistance in each active and passive element in the transmission line, loss is unavoidable. International Organization for Standardization (ISO) should generate power online in order to cope up with P losses although suppliers also make up for the losses.
3. Supplemental operating reserve: Supplemental-operating reserve includes generating units, which must supply power within ten minutes and must be completely available within thirty minutes.
4. Reliability reserve: Reliability reserve includes generating units and spinning reserves, which must be made available completely within ten minutes.
5. Operating reserve: Operating reserve ancillary service is used to balance the power generation to the load because of unexpected outages.
6. Load following: Load-following ancillary service includes two functions performed by the control area (interconnection frequency maintenance and load balance) and two more functions performed by customer (monitoring fluctuations in load and keeping in track of long-term changes). Thus, there are four different components in load following ancillary service.
7. Scheduling and dispatch: Scheduling is a separate ancillary service and not connected to dispatch, but they are lumped together since they are less expensive and coordinated by ISO. Scheduling is to anticipate load requirement and assign generating units accordingly. Dispatch is the actual control of generation units and transmission units, which are available in order to satisfy the load demand. Scheduling, as well as dispatch, are quite inexpensive.

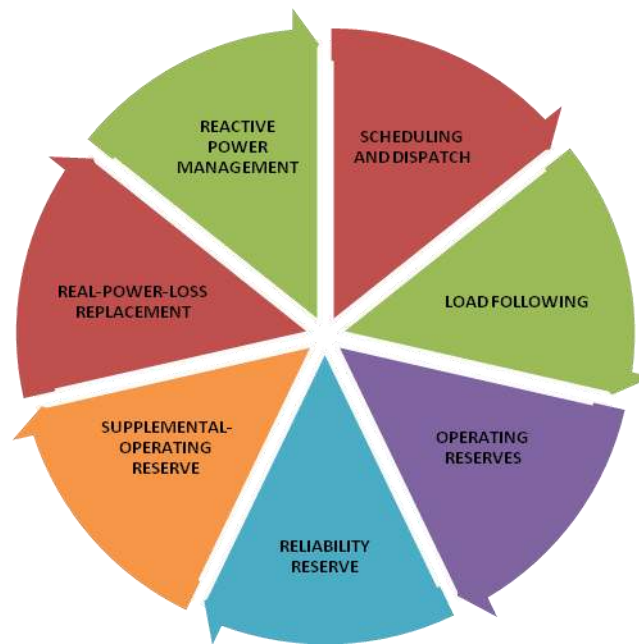

Figure 2. Popular ancillary services in electric power market suggested by FERC.

2.3. Additional Services in Electric Power Market

Figure 3 shows additional services in electric power market suggested by FERC. They are:

1. **Black start capability:** Under certain conditions in which the system collapses, drawing power from the grid becomes an impossible event. Thus, some special generating units called black start units are used to restart devoid of taking power from grid.
2. **Time correction:** Generally, most of the electrical clocks work by means of counting the cycles in the frequency of power. Although this frequency is kept constant, there will be an error of 0.01 Hz. If time correction were not done, there would be an error of roughly 10 s a day considering 50 Hz cycle.
3. **Standby Service:** Standby service serves as a generating capacity, which is kept at reserve to supply energy when emergencies occur. Standby capacity is used in circumstances in which a customer's power is interrupted due to an outage or when the generating unit is under scheduled maintenance or when a customer's power demand exceeds the actual contracted one.
4. **Planning Reserve:** It serves as a planned generating unit based on customer requirement. Hence, it is a customized one and cannot be the same for all customers.
5. **Redispatch:** Due to transmission losses and constraints, least cost power dispatch is not possible. This is known as congestion. In order to avoid congestion, redispatch is done to adjust the power that is input to the transmission line. This method is applied within control areas.
6. **Transmission Services:**
 - Transmission system monitoring and control
 - Transmission reserves
 - Repair and maintenance of the transmission network
 - Metering, billing and communications.
7. **Power Quality:** Power quality means provision of uninterrupted power which is purely sinusoidal to customers
8. **Planning, Engineering & Accounting Services:**
 - a. **Planning services:**

- Load forecasting
 - Scheduling
 - Coordination of the maintenance of generating units
 - Coordination of power transmission maintenance and power outages.
- b. Engineering services:
- Black-start studies
 - Load-flow analysis
 - Planning for bulk-power system expansion.
- c. Accounting services:
- Scheduling
 - Billing
 - Contract administration
 - Reporting to several regulatory bodies.



Figure 3. Additional services in electric power market suggested by FERC.

2.4. Q Injection to Grid

One of the primary ancillary services that is necessary for a power system operator is Q injection to grid [5]. In Figure 4, the red curve indicates the capability of the PV inverter to provide Q. Furthermore, based on the voltage at point of common coupling (PCC), freedom of having higher current distortion is permissible. Several countries have added Reactive power injection to grid into the countries' standard grid code (GC) requirements. In general, if a country follows standard GC, power generation by PVs is required to cease immediately when there is a fault occurring in the grid. However, because of high level of penetration of PVs into grid, a sudden and quick power interruption due to a fault in the grid would cause severe problems. For to this reason, many countries like Spain, Italy, Germany and Japan have modified their GCs [6–9].

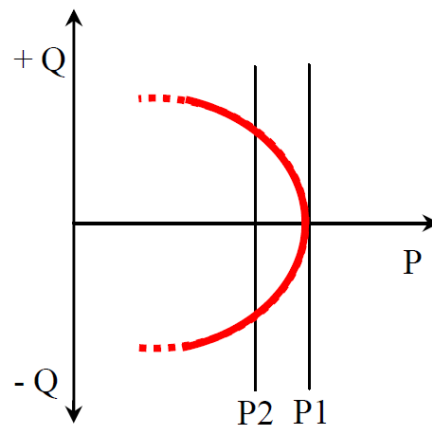

Figure 4. PV inverter reactive power capability based on current limits.

There are numerous services that can be extracted with the use of PVs. Figure 5 shows some of the important ancillary services involving solar PVs. It can be noted that ancillary services provided by PV systems open an important pathway in electric power market and Q injection to grid has been area of research for the last three decades [10–22].

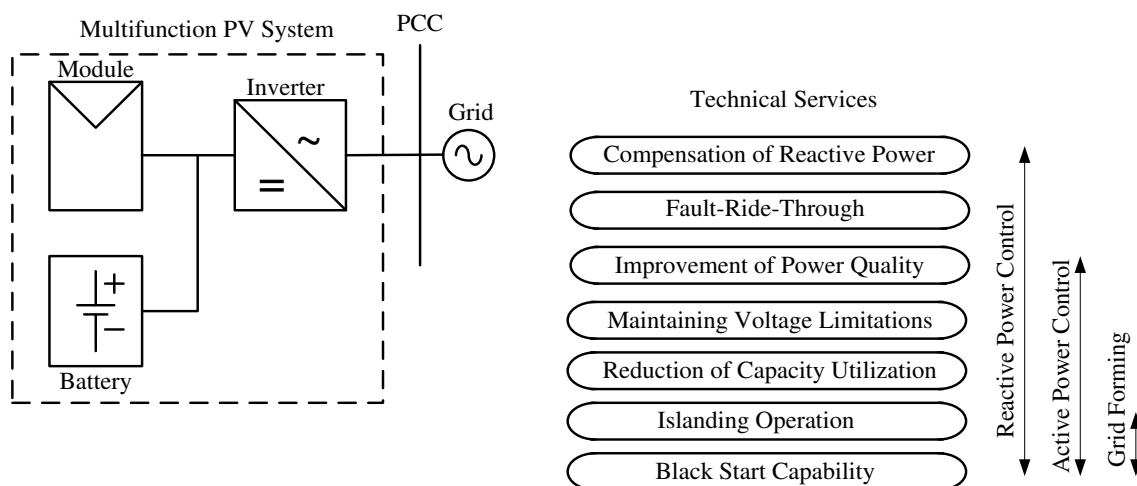

Figure 5. Services provided by PV systems.

Solar-PV panels do not possess Q, since they provide electric power by using PV effect. The power conversion from DC of solar panels to AC injected to grid takes place due to inverter circuitry. This inverter has the capability of providing Q support in fault/normal conditions. Inverters could provide various other ancillary services. Some of these such as low-voltage ride-through (LVRT) and MPPT have become necessary. Although, Q support has not been made mandatory for grid connected PV systems, the higher penetration levels of PVs indicate more accessibility to control of P and Q. Hence, it would become a code included in GCs of all countries using more renewable form of power conversion. In general, for PV-grid topologies, the inverter converts the DC of PV panels to alternating current (AC) that is to be supplied to grid. Figure 6 shows a single-phase PV-grid system that can be used for requirements up to 7 kW. There are many types of inverters that are used in a PV-grid scenario. In the following section, a brief summary of inverter topologies for use in grid-connected systems is provided.

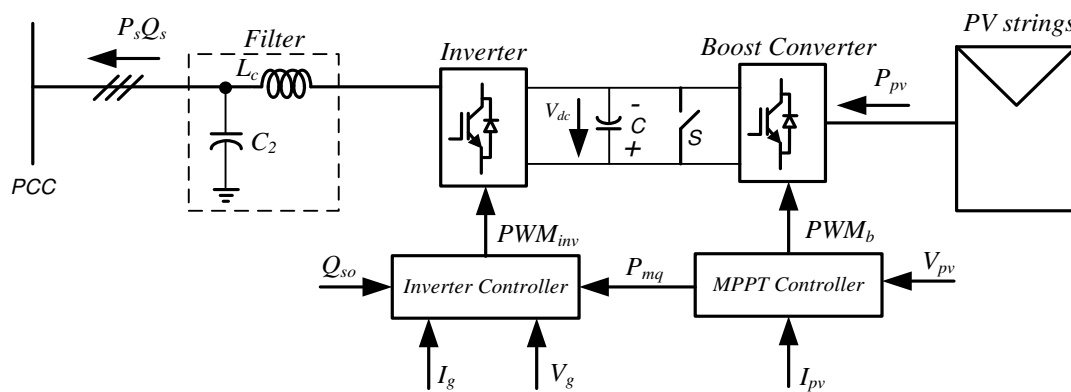

Figure 6. A sketch of single-phase PV-grid system.

3. PV-Grid Inverters—A Summary of Different Topologies

Numerous works have been proposed in literature to illustrate various topologies of inverters including state-of-art review [23]. Traditional inverters such as voltage source inverter (VSI) and current source inverter (CSI) have a major drawback, i.e., voltage buck and boost actions cannot take place simultaneously. In order that buck and boost actions take place collectively, an additional converter has to be added in the circuitry, making the whole system more expensive. Popular impedance source inverters (ZSIs) have been discussed in the literature; they have the ability to overcome the major disadvantage of involving a two-stage topology in power conversion. Both boosting and bucking actions are possible with this topology. ZSI is a combination of VSI and CSI. Boosting of voltage takes place at the DC link with the help of a unique technique called shoot-through [24,25]. In recent years, an interesting inverter topology namely admittance source inverter (YSI) was introduced. The following section gives an overview on different inverter topologies available in literature.

3.1. Traditional Inverters Vs Multilevel Inverters

One of the traditional configurations of inverters that is connected to power grid is VSI (shown in Figure 7). In VSIs, the output voltage is always lesser than the input voltage. VSIs have the ability to introduce currents with low harmonics into the grid. When a CSI (shown in Figure 8) is used instead of VSI, current injection to grid can take place without the need of an additional converter. The output from a VSI and CSI comprises of two unique levels of voltage, but it suffers from higher switching losses. The rate of change of voltage (dv/dt) is higher for traditional two-level inverters. The frequency of switching is also high. They are most suited for low voltage applications.

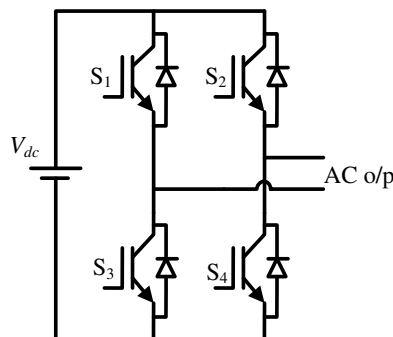

Figure 7. Voltage source inverter.

Multilevel inverters (MLIs) were introduced to overcome the drawbacks of traditional inverters. The classification of MLIs is given in Figure 9. Switching losses are a main factor of concern in two level inverters. Using MLIs, they can be minimized. MLIs aid to reduce switching losses and harmonics.

They can be used for high voltage applications. The rate of change of voltage (dv/dt) is lesser for MLIs. The levels of voltage could be increased to greater than two. Hence, a pure sinusoidal waveform is obtained as the output of the inverter. The harmonics in the output are mitigated and losses could be reduced largely. With the introduction of multilevel topology in CSI (shown in Figure 10), low harmonic currents are obtained. The frequency at which the switching action takes place is reduced with the introduction of a multilevel topology for a current source inverter. A brief comparison between traditional inverters and multilevel inverters is presented in Table 1. Table 2 summarizes the state of art PV grid inverter topologies of MLIs.

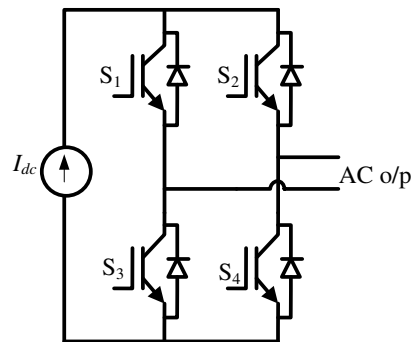

Figure 8. Current source inverter.

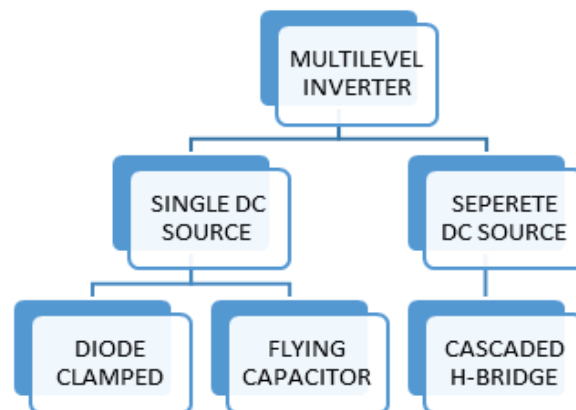

Figure 9. Classification of multilevel inverter topologies.

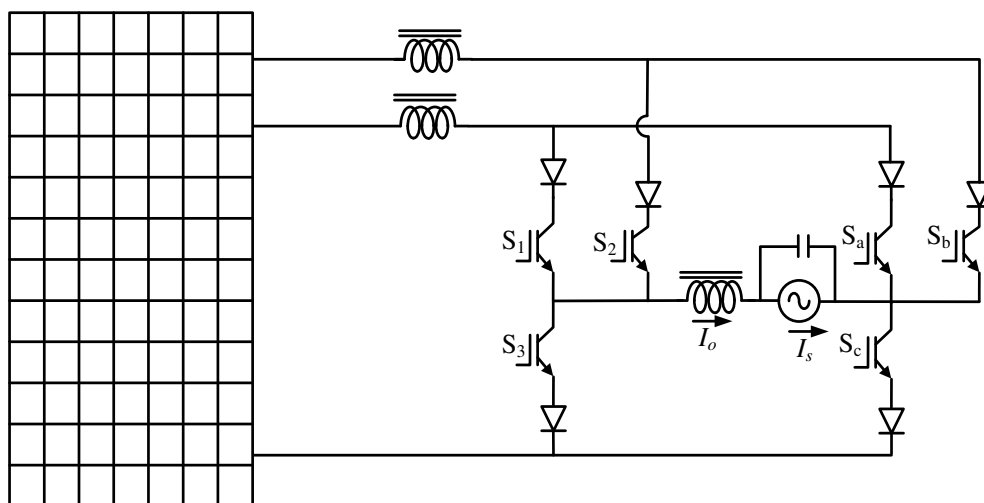

Figure 10. A multilevel CSI topology.

Table 1. Traditional two-level inverters Vs MLI.

Factor under Consideration	Two Level Inverter	Multilevel Inverter
Switching loss	High	Low
dv/dt	High	Low
Voltage stress on switches	More	Less
Switching frequency	High	Low
Levels of voltage in output	Two	more than two
Harmonics	More	Less

Table 2. State of art PV grid inverter topologies of MLIs.

Network Structure	Advantages	Disadvantages
Diode-Clamped	<ul style="list-style-type: none"> Control of Reactive power flow is possible. High efficiency. Filters are not essential to reduce harmonics. 	<ul style="list-style-type: none"> For high levels of diode-clamped structure, the number of diodes required is more. Control of Real power flow for individual converter is tedious.
Flying Capacitors	<ul style="list-style-type: none"> Extra ride through capability during power outage. It gives proper switching combination to balance different voltage levels. Real and reactive power flow can be controlled No need of filters to reduce harmonics. 	<ul style="list-style-type: none"> The number of capacitors required is high for high level. For real power transmission, losses and switching frequency are high
Cascade Multilevel Inverter With Separate DC Sources	<ul style="list-style-type: none"> Because of same structure, it allows the scalable, modularized circuit layout and packaging. Less number of components is needed for getting same number of voltage level. No need of extra diodes and capacitors. 	<ul style="list-style-type: none"> Separate DC sources are required for the real power conversion.

3.2. Concept of Z Source and Its Application in Solar Industry

Even though multilevel inverters have shown better performance than traditional inverters, they still have drawbacks. The number of switches is quite high in an MLI. Although the switches required need smaller rating, the number of required switches is high, thus making the circuit complex and costly. Thus, ZSIs with several advantages over the aforementioned inverters were introduced. Figure 11 shows a voltage fed ZSI.

A ZSI is a combination of inductors and capacitors. A ZSI would operate as a VSI or CSI depending on the application. The output voltage ranges from zero to infinity. Many researchers have adapted impedance source topologies and many advances in the topologies have been listed in literature like YSIs and their advancements [26,27] and ZSIs and their advancements [28–65]. Figure 12a–c give an overall classification of topologies of impedance source networks. A summary of these topologies, as presented in different literature works, is presented in the following section.

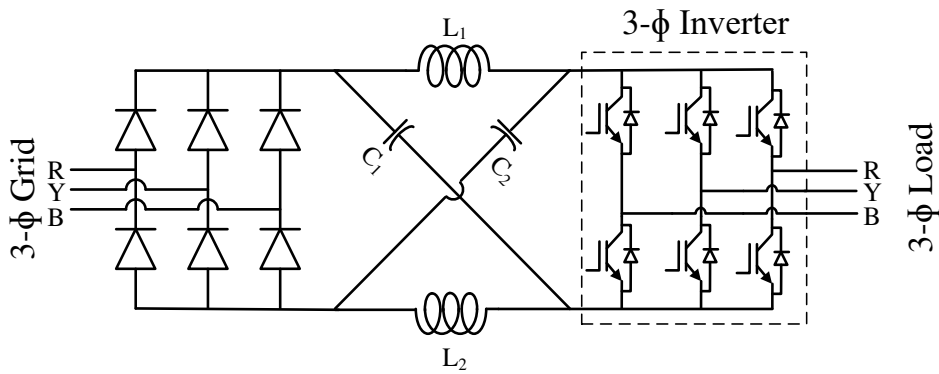

Figure 11. A voltage fed ZSI.

Solar modules are widely preferred in both residential and commercial applications. PV cells are connected in parallel and series in order to form one module. Many such modules in combination is a panel. To develop economical and efficient PV systems, MPPT algorithms are used. Generally, the inverter portion of the PV-inverter-grid structure comprises of a boost circuit and a filter. MPPT algorithms may or may not be used depending upon the application. In PV systems, in order to obtain dc-ac conversion, ZSI is an intelligent choice [66]. ZSIs can boost the voltage levels with a very compact structure. For a 10 kilowatt (kW) PV system, 20 kW inverter is required with a traditional inverter but by using ZSIs, a 10 kW inverter is enough for a 10 kW PV system with same kilo volt-ampere (KVA) maintained. Traditional inverters pose challenges in their control and modulation mechanisms. These issues are eradicated using ZSIs.

The boost factor for a simple boost control method can be obtained from Equations (1) and (2) where M is the modulation index, and B is the Boost factor, T is the total time-period, which is one complete cycle. T0 is the time-period for which the output waveform is obtained.

$$B = 1 / (2M - 1) \tag{1}$$

$$1 - M = T_0 / T \tag{2}$$

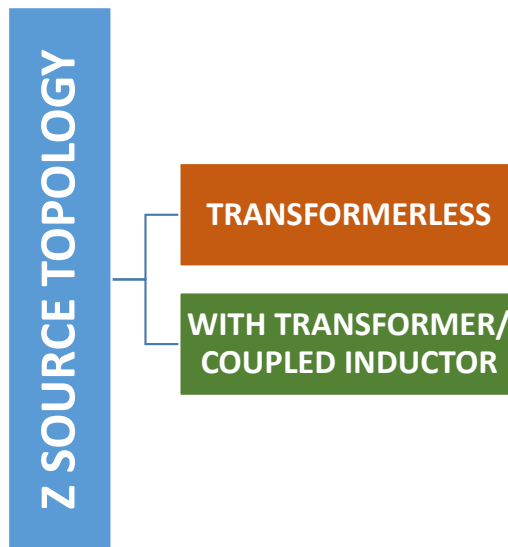

(a)

Figure 12. Cont.

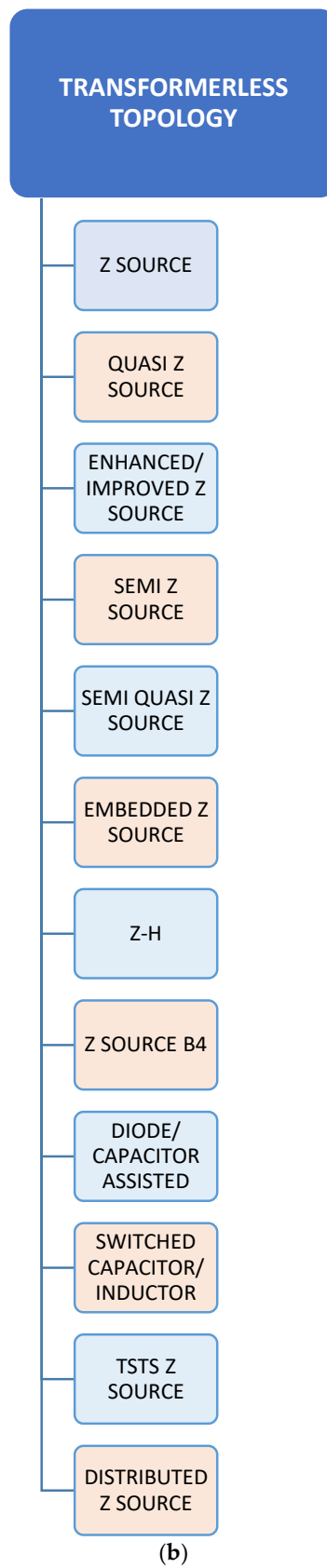

Figure 12. Cont.

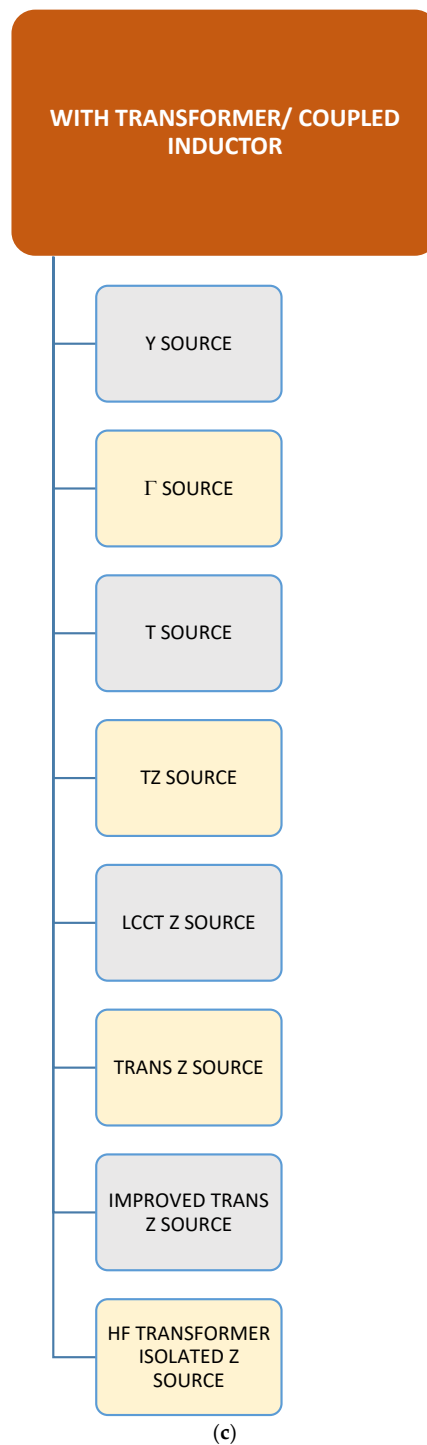

Figure 12. (a) Broad classification of Z source network topologies. (b) Classification of Z source transformerless topologies. (c) Classification of Z source topologies with transformer/coupled inductor.

Summaries of state of the art PV-grid inverter topologies of Z source networks without transformer and with transformer/coupled inductor are presented in Tables 3 and 4 respectively. The features of each structure with components used, including passive elements and semiconductor devices peer reviewed from different literature works are listed. Detailed topological figures can be obtained from the respective reference papers cited for each structure listed in the tables.

Table 3. State of art PV grid inverter topologies of transformer less Z source networks.

Network Structure	NOS	NOC	NOL	Features
Z-Source [67]	1 Diode	2	2	<ul style="list-style-type: none"> • The first introduced, basic circuit to overcome conceptual and theoretical barriers of VSI and CSI. • The inductor of current-fed ZSI must sustain high currents. • Many topologies are derived from this topology. • Discontinuous input current and higher voltage stress on capacitors.
Quasi Z-Source [68]	1 Diode	2	2	<ul style="list-style-type: none"> • The very first change of Z-source network. • Continuous input current. • Reduced passive component ratings. • Reduced component count.
Improved Z-Source [31,32]	1 Diode	2	2	<ul style="list-style-type: none"> • Reduced capacitor voltage stress. • Limit inrush current at start up.
Semi Z-Source, Semi Quasi Z-source [33–35]	2 Switches	2	2	<ul style="list-style-type: none"> • Higher voltage stress across switches compared to ZSI/qZSI. • Reduced count of active components. • Lower cost. • Eliminates leakage currents • Most suitable for grid-connected PV system.
Embedded Z-Source [36–38,48]	1 Diode	2	2	<ul style="list-style-type: none"> • Extracts smooth current from the source without adding additional components or passive filter
Z-H Converter [39]	4 Switches	2	2	<ul style="list-style-type: none"> • Shoot through state is not required for voltage boosting. • Diode at front-end is eliminated.
Z-Source B4 [43]	1 Diode	2	2	<ul style="list-style-type: none"> • Reduced number of active semiconductors. • Simplify the control and gating circuitries.
Diode/Capacitor assisted [41,51]	3 diodes 2 diodes	3 4	3 3	<ul style="list-style-type: none"> • Higher voltage boost and lower voltage stress across the capacitor compared to ZSI/QZSI • Number of components increases based on number of stages
Switched capacitor/inductor [17,50]	7 diodes	2	4	<ul style="list-style-type: none"> • Higher voltage boost capability. • Component count increases based on corresponding size and cost • Lower voltage stress across the capacitor compared to ZSI/QZSI
TSTS Z source [45,55]	3 switches	2	3	<ul style="list-style-type: none"> • Reduced number of active semiconductors • Common ground. • Lower device stress. • It has Buck-boost capability. • High power density
Distributed Z source [60]		Distributed Z		<ul style="list-style-type: none"> • Removes discrete passive and active components for Z source design. • Eliminates parasitic effect. • High frequency operation and better efficiency

Table 4. State of art PV grid inverter topologies of Z source networks with transformer/coupled inductor.

Network Structure	NOS	NOC	NOL	Features
Y SOURCE [27]	1 diode	1	Integrated three windings	<ul style="list-style-type: none"> • Better utilization of input voltage • THD is reduced • Versatile • More degrees of freedom for choice of gain of converter • Higher voltage boost and higher modulation index could be achieved • Very high gain could be achieved with small duty cycle
Γ SOURCE [45,53,65]	1 diode	2	One inductor and one two-winding coupled inductor	<ul style="list-style-type: none"> • Higher gain could be achieved by reducing the turns ratio of the coupled inductor • Better spectral performance at the inverter output
T SOURCE [59,61]	1 diode	1	Integrated two windings	<ul style="list-style-type: none"> • Increased voltage gain compared to ZSI and QZSI. • Reduced component stress • Fewer reactive components compared to ZSI and QZSI • Common ground with load
TZ SOURCE [62]	1 diode	2	Two integrated two windings	<ul style="list-style-type: none"> • Produces higher voltage boost with N
LCCT Z SOURCE [54,64]	1 diode	2	One inductor and one two-winding coupled inductor	<ul style="list-style-type: none"> • Continuous input current despite light load condition • Capable of filtering high frequency ripple from input current
TRANS Z SOURCE [46,49,52,58]	1 diode	1	Integrated two windings	<ul style="list-style-type: none"> • Reduced component stress • Increased voltage gain compared to ZSI and QZSI. • Fewer reactive components compared to ZSI and QZSI • Common ground with load
IMPROVED TRANS Z SOURCE [56]	1 diode	2	1 inductor and 1 transformer	<ul style="list-style-type: none"> • Higher boost factor compared to LCCT-ZSIs, QZSI with input LC filter and trans ZSIs • Resonant current suppression is achieved
HF TRANSFORMER ISOLATED Z SOURCE [57]	1 diode 1 switch	4	Two integrated two windings	<ul style="list-style-type: none"> • Input-output isolation • Lower component stress

In Tables 3 and 4, the following abbreviations were used

- NOS—Number of semiconductor devices
- NOC—Number of capacitors
- NOL—Number of inductors

3.3. Grid Integration Configurations, Synchronization & Standards

Grid-integrated PV systems could be of various power levels and sizes. They are designed for specific applications and needs, with a scope ranging from one PV module to over 100 MW [69]. Hence, a generic PV-inverter-grid structure, as shown in Figure 13, could vary for each plant.

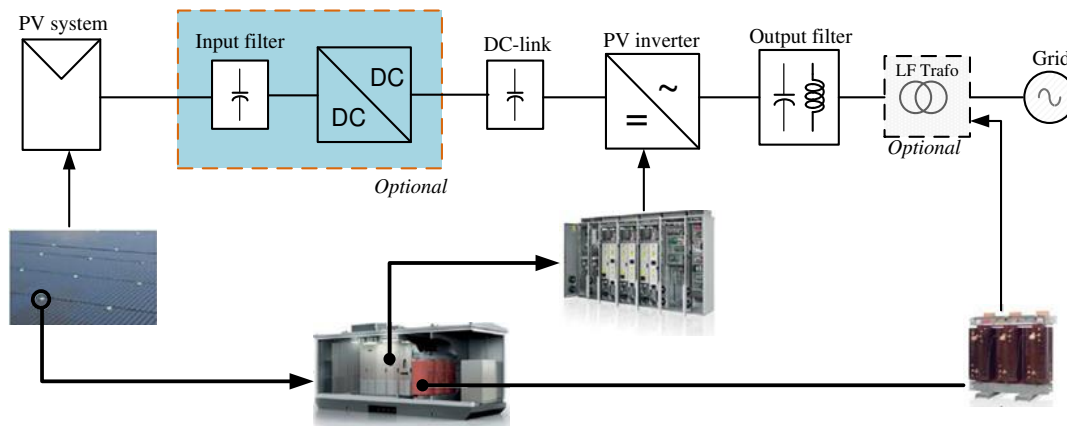

Figure 13. A generic structure of a PV-inverter-grid structure (Picture courtesy of ASEA Brown Boveri).

In order to make things seem less complex, PV-grid systems are divided based on power rating into

- Small scale (a few Ws a few tens of kW)
- Medium scale (a few tens of kW to a few hundreds of kW) and
- Large scale (a few hundred kW to several hundreds of MW).

Table 5 gives a summary of PV-grid-inverter configurations along with pros and cons of each configuration to provide a clear-cut guidance in choosing the type of system depending upon the requirements.

Table 5. PV grid inverter configurations—An Overview.

Comparative index	Small Scale	Medium Scale	Large Scale
Power range	<350 W	<10 kW	<850 kW
Configuration	AC module	String	Central
Power semiconductor device(PSD)	MOSFET	MOSFET, IGBT	IGBT
Inverter efficiency	Lowest	High	Highest
Pros	<ul style="list-style-type: none"> • Flexible/modular • Highest MPPT efficiency • Easy installation 	<ul style="list-style-type: none"> • Good MPPT efficiency • Reduced dc wiring • Transformerless (most common) 	<ul style="list-style-type: none"> • Simple structure • Highest inverter efficiency • Reliable
Cons	<ul style="list-style-type: none"> • Higher losses • Higher cost per watt • Two stage is mandatory 	<ul style="list-style-type: none"> • High component count • One string, one inverter 	<ul style="list-style-type: none"> • Needs blocking diodes (for array) • Not flexible

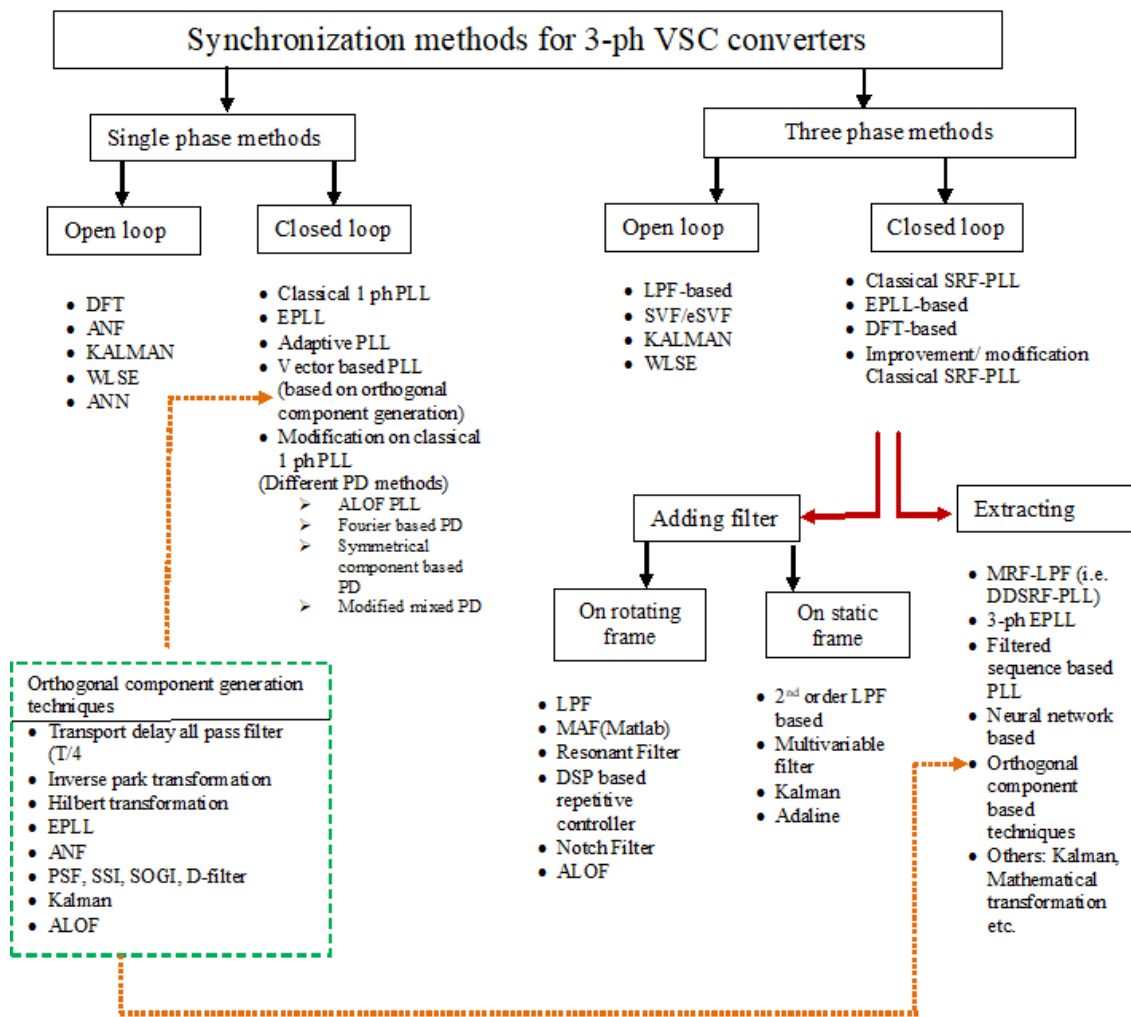

Figure 14. PV-Grid Synchronization methods. Reproduced from [70], 14th European Conference on Power Electronics and Applications (EPE): 2011.

Synchronization of the inverter with the grid is a major challenge in grid integration. Typically, inverters operate like current sources that inject the current in phase with grid voltage [71]. Therefore, pf needs to be maintained at unity or near to unity while the grid is connected to an inverter system. The most important thing is the synchronization of the inverter with the grid voltage. The rule of thumb for synchronization is that the total real power of the grid must be equal to the voltage of the grid and current of the inverter summed. Based on the synchronization rule, the Equation (3) is derived.

$$P(\text{grid}) = V(\text{grid}) + I(\text{inverter}) \tag{3}$$

Several methodologies can be studied from literature for synchronization of grid and PV inverter. Figure 14 gives a brief of literature works surveyed in this regard. Grid integration and the injection of current into the grid play a critical role in the operation of a grid connected PV system. Different works have highlighted current injection into the grid in accordance with recommended standards [72–87].

Due to the increase in PV-grid applications, many standards and GCs are proposed in order to have secure transmission of power into grid. Some of the well-known bodies that develop the standards are Institute of Electrical and Electronic Engineers (IEEE) of USA, IEC of Switzerland and Deutsche Kommission Elektrotechnik (DKE) of Germany. A summary of these standards and GCs is given in Table 6.

Table 6. A Summary of International codes for PV applications.

Category	Codes	Area of Implication
Grid connected	IEC 61727, IEC 60364-7-712	Installations of buildings.
	IEC 61683, IEC 62093, IEC 62116	Utility interface Measuring efficiency.
	UL 1741, IEC 62446	Interconnected PV inverters, system documentation & commissioning tests Useful in independent power systems
EMI	EN61000	European Union EMC directive for residential, private sectors, light industrial and commercial facilities.
	FCC Part 15	U.S. EMC directive for residential, commercial, light industrial, and industrial facilities
Low voltage ride through (LVRT)	IEC 61727	$V < 50\%$ at 0.1s $50\% \leq V < 85\%$ at 2.0 s
Anti-islanding	IEEE 1547/UL 1741 IEC 62116	Island detection
	VDE 0126-1-1	Impedance measurement
Monitoring	IEC 61850-7, IEC 60870, IEC 61724,	Transmission grids and systems for power service automation Distributed energy resources and logical nodes Measurement, data exchange, and analysis
Off grid	IEC 62509, IEC 61194, IEC 61702	Battery charge controllers
	IEEE Standard 1526, IEC/PAS 62111	Stand-alone systems
	IEC 62124	Rating of direct-coupled pumping systems Specifications for rural decentralized electrification.
Rural systems	IEC/TS 62257	Medium-scale renewable energy and hybrid systems. Safeguard from electrical hazards. Choice to select generator sets and batteries. Micro power systems and microgrids.

4. A Summary of Intelligent Algorithms & Optimization Techniques in Grid-Tied Inverters

Due to a rapid increase in complexity, optimization has become necessary in the design of every system. When PVs are involved, it means that there is going to be intermittency in the output power. In order that the load is fed without any fluctuation, optimization techniques must be incorporated to get smoother and better output. In order to understand modern intelligent algorithms and optimization techniques, one must have an understanding on the computational intelligence, which is used along with optimization techniques. Figure 15 lists the computational intelligence platforms that are discussed briefly in the following section.

1. Artificial Neural Network (ANN): The ANN was originally introduced by Rosenblatt [85]; it is a replica of human brain, and is useful for forecasting the availability of renewable energy [86].
2. Fuzzy Logic (FL): FL is used in decision making. The theory behind its application pertaining to current area of study can be found in [87], and the methodology for practical application in Renewable energy systems can be inferred from [88].
3. Multiagent system (MAS): Every component in the system is represented as an agent with unique objectives. A detailed review on the subject can be studied in [89].

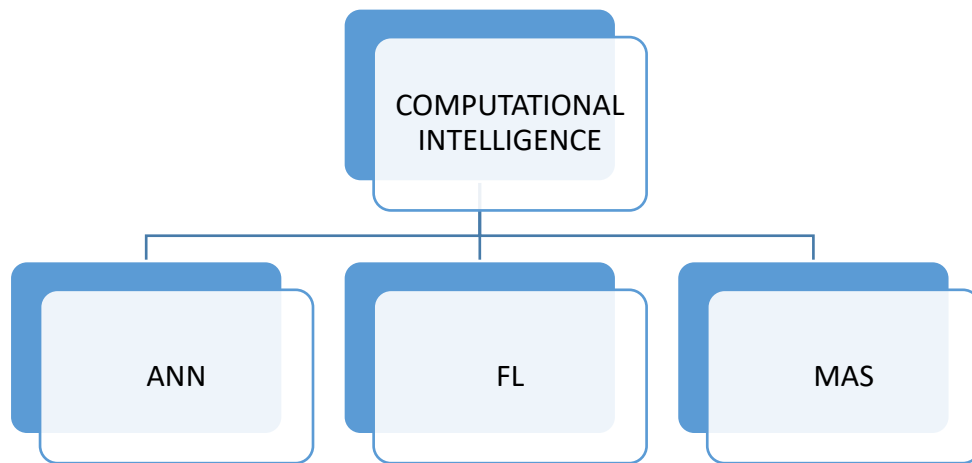
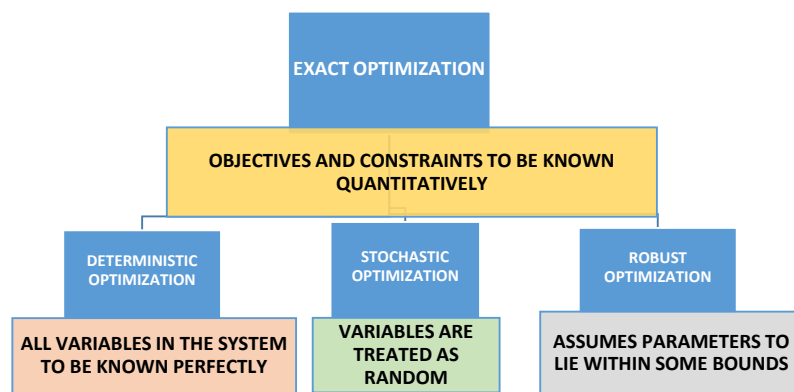
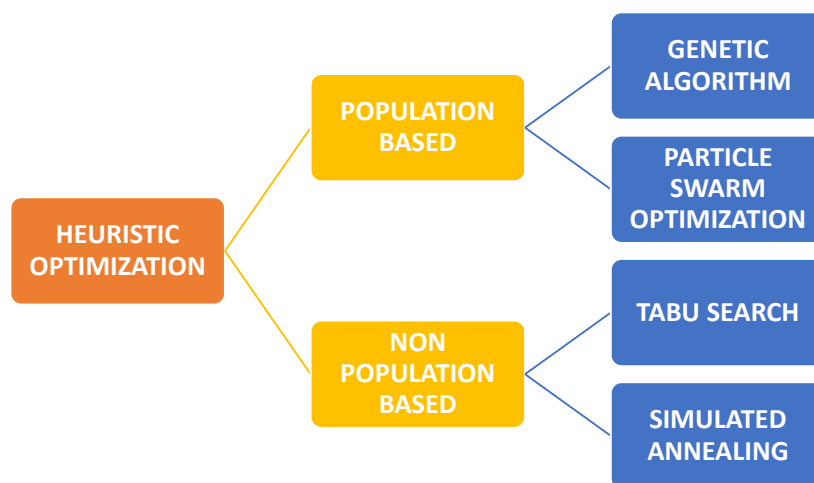

Figure 15. Computational intelligence techniques.

Figure 16a shows the classification of exact optimization depending on treatment of uncertainties. Figure 16b shows the classification of heuristic optimization. Table 7 lists the optimization techniques used in transmission and distribution systems with Q as one of the control variables. Table 8 summarizes various Q control techniques applied to the different sets of surveyed configurations.



(a)



(b)

Figure 16. (a) Classification of exact optimization depending on treatment of uncertainties. (b) Classification of Heuristic optimization.

Table 7. A summary of literature works surveyed related to optimization.

Objective Function	Optimization Tool	Control Variables	System Type
Minimize P loss [90]	SO (SOCP)	Q of PV, subject to stochastic P of PV	Distribution
Minimize total cost of a distribution system [91]	PSO	Q of PV, Q of EV	Distribution
Minimize P loss [92]	ES	Generator bus voltages, tap positions of transformer, Q of capacitor banks	Transmission
Minimize P loss [93]	Ant colony optimization (ACO)	Generator bus voltages, tap positions of transformer, Q of capacitor banks	Transmission
Minimize P loss [94]	PSO	Q of PV, P and Q of Battery Energy storage system (BESS), CL, tap positions of transformer	Distribution

Table 8. A summary of control techniques surveyed.

Configuration	Features/Control Scheme Employed
AC stacked PV inverter architecture [87]	<ul style="list-style-type: none"> No need for communications between inverters Combined Constant Peak Current Control and Constant Active Power Control Grid inductor is very small (50 micro Henry)
8 bus radial test feeder used for sensitivity analysis [95]	<ul style="list-style-type: none"> $\cos\phi(P,U)$ and $Q(U)$ methods employed pf control in terms of injected active power and local grid-voltage dependent reactive power is illustrated.
Distributed PV Generators [86]	<ul style="list-style-type: none"> Decentralized method for Q flow control is adapted Inverter Q is produced as a function of P [Q(P)] German GC is followed
16 bus and 81 bus distribution systems [96]	<ul style="list-style-type: none"> A Q planning model is proposed Provides extra VAR capacity Short-term planning and decision Uses APL and UC for control
1 main feeder and 6 laterals. 4 loads connected to main feeder at different points. 10 loads are derived from 6 laterals [76].	<ul style="list-style-type: none"> Auto-adaptive controller is used. During daylight, PV generates P; Q injection is reduced. During the absence of sunlight, Q equal to rated power is injected into the grid. Sensitivity theory and Lyapunov theorem are used.
Cigré 32 bus system [63,78]	<ul style="list-style-type: none"> GAMS/MINOS5 solver is used for solving Non-linear programming (NLP) Emphasis is laid on design of a competitive market for Q ancillary service from generator.
7 level QZSI with TSC and TSR [97,98]	<ul style="list-style-type: none"> A unique master-slave controller is proposed This topological advancement saves 42 percent of inverter rating.

5. Conclusions and Future Scope

Grid-tied inverter topologies are important components for the interface between the RER and the utility grid. Now, single-phase, transformerless configurations of range 1–10 kW are gaining interest. When compared to transformer-based configurations, the main advantages of transformerless configurations are:

- Less complexity
- Lower cost
- Higher efficiency
- Lighter weight
- Smaller volume

Thanks to the technological advancements in the area of power electronics, numerous transformerless inverters derived from conventional H-bridge topology have been developed. These inverters offer high efficiency and reliability. They also have lower electromagnetic interference, since transformers or coupled inductors are not involved in the design. In recent times, low-efficiency PV arrays have been widely used. In order to achieve maximal efficiency, the materials involved in fabrication of PV panels need to be carefully investigated and used. In this paper, a critical review of grid connected PV systems was performed. The definition of ancillary services and the reactive power market with reactive power as an ancillary service was examined. A review of the different topologies of inverters with special reference to state of art topologies such as γ source inverter derivatives was presented. Unique aspects of each topology in terms of structure and functional merits/demerits were presented in detail. In the coming era, a basic understanding of power converters becomes necessary for the successful integration of PVs with grid. Fulfilling the GC requirements also becomes a major challenge. Hence, in this paper, the synchronization between the inverter and the grid was examined, with the aim of outlining important concepts in grid synchronization and standards. Finally, intelligent algorithms and optimization techniques surveyed from different literature works were listed. A summary of different works available in the literature has been presented with the aim of providing researchers with an overview of grid-connected architectures. With the advent of Perovskite material used in solar cells, solar technology has seen tremendous advances. Future work may focus on the manufacturing side of solar cells, since this is currently an area of great discussion.

Author Contributions: All authors contributed equally in this research activities for its final presentation as full research article.

Funding: This research received no external funding.

Conflicts of Interest: The authors declare no conflict of interest.

Nomenclature

Acronyms

AC	Alternating current
ACO	Ant colony optimization
ANN	Artificial neural network
BESS	Battery Energy storage system
CSI	Current source inverter
DC	Direct Current
DO	Deterministic Optimization
DVR	Dynamic voltage restorer
DKE	Deutsche Kommission Elektrotechnik
EA	Evolutionary algorithm
EMF	Electromotive force
EMI	Electromagnetic interference
ESS	Energy storage system
FACTS	Flexible AC transmission system
FERC	Federal Energy Regulatory Commission
FL	Fuzzy logic
FRT	Fault ride-through
GA	Genetic algorithm
GC	Grid code
GW	Giga Watt
HF	High frequency
HVRT	High voltage ride-through
IEC	International Electro technical Commission

IEEE	Institute of Electrical and Electronic Engineers
IGBT	Insulated gate bipolar transistor
ISO	International Organization for Standardization
KVA	Kilo volt ampere
Kw	Kilo watt
LCCT	inductor–capacitor–capacitor–transformer
LVRT	Low voltage ride-through
MAS	Multiagent System
MFAPSO	Multi-function agent based particle swarm optimization
MLI	Multilevel inverter
MOSFET	Metal oxide semiconductor field effect transistor
MPC	Model predictive control
MPPT	Maximum power point tracking
NER	National electricity rules
NLP	Non-linear programming
NSGA	Non-dominated sorting GA
OLTC	On-load tap changer
OPF	Optimal power-flow
PCC	Point of common coupling
PEC	Power electronic converter
PLL	Phase Locked loop
PSD	Power semiconductor device
PSO	Particle swarm optimization
PV	Photovoltaic
PWM	Pulse-width modulation
RO	Robust Optimization
SA	Simulated annealing
SO	Stochastic Optimization
THD	Total Harmonic Distortion
TS	Tabu search
TSC	Thyristor switched capacitor
QZSI	Quasi impedance Source Inverter
VSI	Voltage source inverter
YSI	Admittance source inverter
ZSI	Impedance source inverter
Variables	
X	Reactance
δ	Angle between stator voltage and internal emf
ϕ	Angle between voltage and current
S	Apparent power
P	Real power
Q	Reactive power
V	Voltage
I	Current
E	Electromotive force
D	Duty cycle
T	Time period
m	Modulation index
W	Watt
kW	Kilowatt
MW	Megawatt

References

1. International Energy Agency. Renewables 2017: Analysis and Forecasts to 2022. Available online: <https://www.iea.org/renewables/> (accessed on 31 October 2018).
2. International Energy Agency. Renewables 2018: Analysis and Forecasts to 2023. Available online: <https://webstore.iea.org/market-report-series-renewables-2018> (accessed on 1 November 2018).
3. Pierno, A.; di Noia, L.P.; Rubino, L. Ancillary services provided by PV power plants. *Leonardo Electron. J. Pract. Technol.* **2016**, *28*, 57–76.
4. Hirst, E.; Kirby, B. *Electric-Power Ancillary Services*; ORNL/CON-426; Oak Ridge National Laboratory: Oak Ridge, TN, USA, 1996.
5. Xavier, L.S.; Cupertino, A.F.; Pereira, H.A. Ancillary services provided by photovoltaic inverters: Single and three phase control strategies. *Comput. Electr. Eng.* **2018**, *70*, 102–121. [[CrossRef](#)]
6. Yang, Y.; Blaabjerg, F.; Wang, H. Low-voltage ride-through of single-phase transformerless photovoltaic inverters. *IEEE Trans. Ind. Appl.* **2014**, *50*, 1942–1952. [[CrossRef](#)]
7. Comitato Elettrotecnico Italiano. *Reference Technical Rules for Connecting Users to the Active and Passive LV Distribution Companies of Electricity*; CEI: Milan, Italy, 2011.
8. Stetz, T.; Marten, F.; Braun, M. Improved low voltage grid-integration of photovoltaic systems in Germany. *IEEE Trans. Sustain. Energy* **2013**, *4*, 534–542. [[CrossRef](#)]
9. Miyamoto, Y. Technology for high penetration residential PV systems. In Proceedings of the 5th International Conference on Integration of Renewable and Distributed Energy Resources, Berlin, Germany, 4–6 December 2012.
10. Patel, U.N.; Patel, H.H. An Effective Power Management Strategy for Photovoltaic based Distributed Generation. In Proceedings of the 2016 IEEE 16th International Conference on Environment and Electrical Engineering (EEEIC), Florence, Italy, 7–10 June 2016.
11. Xiao, W.; Edwin, F.; Spagnuolo, G.; Jatskevich, J. Efficient Approaches for Modeling and Simulating Photovoltaic Power Systems. *IEEE J. Photovolt.* **2013**, *3*, 500–508. [[CrossRef](#)]
12. Trabelsi, M.; Abu-Rub, H.; Ge, B. 1-MW Quasi-Z-Source based Multilevel PV Energy Conversion System. In Proceedings of the 2016 IEEE International Conference on Industrial Technology (ICIT), Taipei, Taiwan, 14–17 March 2016.
13. Meraj, M.; Rahman, S.; Iqbal, A.; Ben-Brahim, L.; Alammari, R.; Abu-Rub, H. A Hybrid Active and Reactive Power Control with Quasi Z-Source Inverter in Single-Phase Grid-Connected PV systems. In Proceedings of the IECON 2016—42nd Annual Conference of the IEEE Industrial Electronics Society, Florence, Italy, 23–26 October 2016.
14. Sarkar, M.N.I.; Meegahapola, L.G.; Datta, M. Reactive Power Management in Renewable Rich Power Grids: A Review of Grid-Codes, Renewable Generators, Support Devices, Control Strategies and Optimization Algorithms. *IEEE Access* **2018**, *6*, 41458–41489. [[CrossRef](#)]
15. Liu, L.; Li, H.; Zhao, Y.; He, X.; Shen, Z.J. 1MHz cascaded Z-source inverters for scalable grid-interactive photovoltaic (PV) applications using GaN device. In Proceedings of the 2011 IEEE Energy Conversion Congress and Exposition, Phoenix, AZ, USA, 17–22 September 2011; pp. 2738–2745.
16. Jabr, R.A. ‘Linear decision rules for control of reactive power by distributed photovoltaic generators. *IEEE Trans. Power Syst.* **2017**, *33*, 2165–2174. [[CrossRef](#)]
17. Jafarian, H.; Enslin, J.; Parkhideh, B. On Reactive Power Injection Control of Distributed Grid-tied AC-stacked PV Inverter Architecture. In Proceedings of the 2016 IEEE Energy Conversion Congress and Exposition (ECCE), Milwaukee, WI, USA, 18–22 September 2016.
18. Yang, Y.; Wang, H.; Blaabjerg, F. Reactive power injection strategies for single-phase photovoltaic systems considering grid requirements. *IEEE Trans. Ind. Appl.* **2014**, *50*, 4065–4076. [[CrossRef](#)]
19. Ouldamouche, S.; Bouchakour, S.; Arab, H.; Abdeladim, K.; Cherfa, F.; Kerkouche, K. Reactive Power issues in Grid Connected Photovoltaic Systems. In Proceedings of the International Conference on Nuclear and Renewable Energy Resources, Antalya, Turkey, 26–29 October 2014.
20. Gandhi, O.; Rodríguez-Gallegos, C.D.; Brahmendra, N.; Bieri, M.; Reindl, T.; Srinivasan, D. Reactive Power Cost from PV Inverters Considering Inverter Lifetime Assessment. *IEEE Trans. Sustain. Energy* **2018**, *10*, 738–747. [[CrossRef](#)]

21. Solanki, N.; Patel, J. Photovoltaic Solar Farms Operating in VAR Mode: A Review. *J. Power Electron. Power Syst.* **2016**, *6*, 73–85.
22. Pvp, I. *Task 14: Transition from Uni-Directional to Bi-Directional Distribution Grids*; International Energy Agency: Paris, France, 2014.
23. Gupta, A.K.; Samuel, P.; Kumar, D. A state of art review and challenges with impedance networks topologies. In Proceedings of the 2016 IEEE 7th Power India International Conference (PIICON), Bikaner, India, 25–27 November 2016; pp. 1–6. [[CrossRef](#)]
24. Kavya Santhoshi, B.; Kuppusamy, M.; Sivasubramanian, M.; Akila, S. A Novel Multiport Bidirectional Dual Active Bridge Dc-dc Converter for Renewable Power Generation Systems. *Indian J. Sci. Technol.* **2016**, *9*. [[CrossRef](#)]
25. Santhoshi, B.K.; Divya, S.; Kumar, M.S. Selective harmonic elimination for a PV based Quasi—Z Source Inverter for drive systems. In Proceedings of the 2014 IEEE National Conference on Emerging Trends in New & Renewable Energy Sources and Energy Management (NCET NRES EM), Chennai, India, 16–17 December 2014; pp. 143–147.
26. Siwakoti, Y.P.; Blaabjerg, F.; Loh, P.C. Quasi-Y-source inverter. In Proceedings of the 2015 Australasian Universities Power Engineering Conference (AUPEC), Wollongong, Australia, 27–30 September 2015; pp. 1–5. [[CrossRef](#)]
27. Siwakoti, Y.P.; Loh, P.C.; Blaabjerg, F.; Town, G. Y-source impedance network. *IEEE Trans. Power Electron.* **2014**, *29*, 3250–3254. [[CrossRef](#)]
28. Abdelhakim, A.; Davari, P.; Blaabjerg, F.; Mattavelli, P. Analysis and Design of the Quasi-Z-Source Inverter for Wide Range of Operation. In Proceedings of the 2018 IEEE 19th Workshop on Control and Modeling for Power Electronics (COMPEL), Padova, Italy, 25–28 June 2018.
29. Li, Y.; Anderson, J.; Peng, F.Z.; Liu, D. Quasi Z-source inverter for photovoltaic power generation systems. In Proceedings of the 2009 Twenty-Fourth Annual IEEE Applied Power Electronics Conference and Exposition, Washington, DC, USA, 15–19 February 2009; pp. 918–924.
30. Ge, B.; Abu-Rub, H.; Peng, F.Z.; Lei, Q.; de Almeida, A.T.; Ferreira, F.J.T.E.; Sun, D.; Liu, Y. An energy stored quasi-Z-source inverter for application to photovoltaic power system. *IEEE Trans. Ind. Electron.* **2013**, *60*, 4468–4481. [[CrossRef](#)]
31. Tang, Y.; Xie, S.; Zhang, C. An improved Z-source inverter. *IEEE Trans. Power Electron.* **2011**, *26*, 3865–3868. [[CrossRef](#)]
32. Tang, Y.; Xie, S.; Zhang, C.; Xu, Z. Improved Z-source inverter with reduced Z-source capacitor voltage stress and soft-start capability. *IEEE Trans. Power Electron.* **2009**, *24*, 409–415. [[CrossRef](#)]
33. Cao, D.; Jiang, S.; Yu, X.; Peng, F.Z. Low cost single-phase semi-Z source inverter. In Proceedings of the 2011 Twenty-Sixth Annual IEEE Applied Power Electronics Conference and Exposition (APEC), Fort Worth, TX, USA, 6–11 March 2011; pp. 429–436.
34. Cao, D.; Jiang, S.; Yu, X.; Peng, F.Z. Low-cost semi-Z-source inverter for single-phase photovoltaic systems. *IEEE Trans. Power Electron.* **2011**, *26*, 3514–3523. [[CrossRef](#)]
35. Haimovich, H.; Middleton, R.H.; de Nicolo, L. Large-signal stability conditions for semi-quasi-Z-source inverters: Switched and averaged models. In Proceedings of the 52nd IEEE Conference on Decision and Control, Florence, Italy, 10–13 December 2013.
36. Loh, P.C.; Gao, F.; Blaabjerg, F. Embedded EZ-source inverter. *IEEE Trans. Ind. Appl.* **2010**, *46*, 256–267.
37. Gao, F.; Loh, P.C.; Li, D.; Blaabjerg, F. Asymmetrical and symmetrical embedded Z-source inverters. *IET Power Electron.* **2011**, *4*, 181–193. [[CrossRef](#)]
38. Gao, F.; Loh, P.C.; Blaabjerg, F.; Gajanayake, C.J. Operational analysis and comparative evaluation of embedded Z-source inverters. In Proceedings of the 2008 IEEE Power Electronics Specialists Conference, Rhodes, Greece, 15–19 June 2008; pp. 2757–2763.
39. Zhang, F.; Peng, F.Z.; Qian, Z. Z-H converter. In Proceedings of the 2008 IEEE Power Electronics Specialists Conference, Rhodes, Greece, 15–19 June 2008; pp. 1004–1007.
40. Nguyen, M.K.; Lim, Y.C.; Cho, G.B. Switched-inductor quasi-Zsource inverter. *IEEE Trans. Power Electron.* **2011**, *26*, 3183–3191. [[CrossRef](#)]
41. Gajanayake, C.J.; Luo, F.L.; Gooi, H.B.; So, P.L.; Siow, L.K. Extended-boost Z-source inverters. *IEEE Trans. Power Electron.* **2010**, *25*, 2642–2652. [[CrossRef](#)]

42. Loh, P.C.; Blaabjerg, F. Magnetically coupled impedance-source inverters. *IEEE Trans. Power Electron.* **2013**, *49*, 2177–2187. [[CrossRef](#)]
43. Loh, P.C.; Duan, N.; Liang, C.; Gao, F.; Blaabjerg, F. Z-source B4 inverter. In Proceedings of the 2007 IEEE Power Electronics Specialists Conference, Orlando, FL, USA, 17–21 June 2007; pp. 1363–1369.
44. Nguyen, M.K.; Lim, Y.C.; Choi, J.H. Two switched-inductor quasi- Z-source inverters. *IET Power Electron.* **2012**, *5*, 1017–1025. [[CrossRef](#)]
45. Loh, P.C.; Li, D.; Blaabjerg, F. Current-type flipped- Γ -source inverters. In Proceedings of the 7th International in Power Electronics and Motion Control Conference, Harbin, China, 2–5 June 2012; pp. 594–598.
46. Li, D.; Loh, P.C.; Zhu, M.; Gao, F.; Blaabjerg, F. Cascaded multicell trans-Z-source inverters. *IEEE Trans. Power Electron.* **2013**, *28*, 826–836.
47. Zhu, M.; Yu, K.; Luo, F.L. Switched inductor Z-source inverter. *IEEE Trans. Power Electron.* **2010**, *25*, 2150–2158.
48. Itozakura, H.; Koizumi, H. Embedded Z-source inverter with switched inductor. In Proceedings of the IECON 2011—37th Annual Conference of the IEEE Industrial Electronics Society, Melbourne, Australia, 7–10 November 2011; pp. 1342–1347.
49. Qian, W.; Peng, F.Z.; Cha, H. Trans-Z-source inverters. *IEEE Trans. Power Electron.* **2011**, *26*, 3453–3463. [[CrossRef](#)]
50. Li, D.; Loh, P.C.; Zhu, M.; Gao, F.; Blaabjerg, F. Generalized multicell switched-inductor and switched-capacitor Z-source inverters. *IEEE Trans. Power Electron.* **2013**, *28*, 837–848. [[CrossRef](#)]
51. Gajanayake, C.J.; Gooi, H.B.; Luo, F.L.; So, P.L.; Siow, L.K.; Vo, Q.N. Simple modulation and control method for new extended boost quasi Z-source. In Proceedings of the TENCON 2009—2009 IEEE Region 10 Conference, Singapore, 23–26 January 2009; pp. 1–6.
52. Shin, D.; Cha, H.; Lee, J.P.; Yoo, D.W.; Peng, F.Z.; Kim, H.G. Parallel operation of trans-Z-source inverter. In Proceedings of the 8th International Conference on Power Electronics—ECCE Asia, Jeju, Korea, 30 May–3 June 2011; pp. 744–748.
53. Loh, P.C.; Li, D.; Blaabjerg, F. Γ -Z-source inverters. *IEEE Trans. Power Electron.* **2013**, *28*, 4880–4884. [[CrossRef](#)]
54. Adamowicz, M.; Strzelecki, R.; Peng, F.Z.; Guzinski, J.; Rub, H.A. New type LCCT-Z-source inverters. In Proceedings of the 2011 14th European Conference on Power Electronics and Applications, Birmingham, UK, 30 August–1 September 2011; pp. 1–10.
55. Huang, L.; Zhang, M.; Hang, L.; Yao, W.; Lu, Z. A family of three switch three-state single-phase Z-source inverters. *IEEE Trans. Power Electron.* **2013**, *28*, 2317–2329. [[CrossRef](#)]
56. Nguyen, M.K.; Lim, Y.C.; Park, S.J. Improved trans-Z-source inverter with continuous input current and boost inversion capability. *IEEE Trans. Power Electron.* **2013**, *28*, 4500–4510. [[CrossRef](#)]
57. Jiang, S.; Cao, D.; Peng, F.Z. High frequency transformer isolated Z-source inverters. In Proceedings of the 2011 Twenty-Sixth Annual IEEE Applied Power Electronics Conference and Exposition (APEC), Fort Worth, TX, USA, 6–11 March 2011; pp. 442–449.
58. Jiang, S.; Peng, F.Z. Modular single-phase trans-Z-source inverter for multi-input renewable energy system. In Proceedings of the 2012 Twenty-Seventh Annual IEEE Applied Power Electronics Conference and Exposition (APEC), Orlando, FL, USA, 5–9 February 2012; pp. 2107–2114.
59. Kumar, S.P.; Shailaja, P. T-shaped Z-source inverter. *Int. J. Eng. Res. Technol.* **2012**, *1*, 1–6.
60. Peng, F.Z. Z-source network for power conversion. In Proceedings of the 2008 Twenty-Third Annual IEEE Applied Power Electronics Conference and Exposition, Austin, TX, USA, 24–28 February 2008; pp. 1258–1265.
61. Strzelecki, R.; Adamowicz, M.; Strzelecka, N.; Bury, W. New type T-source inverter. In Proceedings of the 2009 Compatibility and Power Electronics, Badajoz, Spain, 20–22 May 2009; pp. 191–195.
62. Nguyen, M.K.; Lim, Y.C.; Kim, Y.G. TZ-source inverters. *IEEE Trans. Ind. Electron.* **2013**, *60*, 5686–5695. [[CrossRef](#)]
63. Bhattacharya, K.; Zhong, J. Reactive power as an ancillary service. *IEEE Trans. Power Syst.* **2001**, *16*, 294–300. [[CrossRef](#)]
64. Adamowicz, M.; Strzelecki, R.; Peng, F.Z.; Guzinski, J.; Rub, H.A. High step-up continuous input current LCCT-Z-source inverters for fuel cells. In Proceedings of the 2011 IEEE Energy Conversion Congress and Exposition, Phoenix, AZ, USA, 17–22 September 2011; pp. 2276–2282.
65. Mo, W.; Loh, P.C.; Blaabjerg, F. Asymmetrical Γ -source inverters. *IEEE Trans. Ind. Electron.* **2014**, *61*, 637–647. [[CrossRef](#)]

66. Kavya Santhoshi, B.; Mohana Sundaram, K. Hybrid Converter with Simultaneous AC and DC Output for Nano-Grid Applications with Residential System. *J. Eng. Appl. Sci.* **2018**, *13*, 3289–3293.
67. Peng, F.Z. Z-source inverter. *IEEE Trans. Ind. Appl.* **2003**, *39*, 504–510. [[CrossRef](#)]
68. Anderson, J.; Peng, F.Z. Four quasi-Z-source inverters. In Proceedings of the 2008 IEEE Power Electronics Specialists Conference, Rhodes, Greece, 15–19 June 2008; pp. 2743–2749.
69. First Solar Sarnia PV Power Plant, Ontario, Canada. Available online: <http://www.firstsolar.com/en/Projects/Sarnia-Solar-Project> (accessed on 19 December 2013).
70. Boyra, M.; Thomas, J.-L. A review on synchronization methods for grid-connected three phase VSC under unbalanced and distorted conditions. In Proceedings of the 2011-14th European Conference on Power Electronics and Applications (EPE), Birmingham, UK, 30 August–1 September 2011; pp. 1–10.
71. Mohana Sundaram, K.; Anandhraj, P.; Vimalraj Ambeth, V. PV-Fed Eleven-Level Capacitor Switching Multi-Level Inverter for Grid Integration. In *Advances in Smart Grid and Renewable Energy*; Sen Gupta, S., Zobaa, A., Sherpa, K., Bhoi, A., Eds.; Lecture Notes in Electrical Engineering; Springer: Singapore, 2018; Volume 435.
72. IEEE 929-2000. *IEEE Recommended Practice for Utility Interface of Photovoltaic (PV) Systems*; IEEE: Piscataway, NJ, USA, 2000.
73. Committee EL-042. AS 4777.2—2005. *Grid Connection of Energy Systems via Inverters. Part 2: Inverter Requirements*; Australian Standard: Sydney, Australia, 2005.
74. Oliva, A.; Chiacchiarini, H.; Aymonino, A.; Mandolesi, P. Reduction of Total Harmonic Distortion in Power Inverters. *Lat. Am. Appl. Res.* **2005**, *35*, 89–93.
75. Çelebi, A.; Çolak, M. The effects of harmonics produced by Grid connected photovoltaic systems on electrical networks. Available online: http://www.emo.org.tr/ekler/0172ea66506f59c_ek.pdf (accessed on 25 November 2018).
76. Watson, N.R.; Miller, A. Power Quality Indices: A Review. In Proceedings of the EEA Conference & Exhibition, Wellington, Newzealand, 24–26 June 2015.
77. IEEE Standard 519-2014. *IEEE Recommended Practices and Requirements for Harmonic Control in Electric Power Systems*; IEEE Power and Energy Society: Piscataway, NJ, USA, 2014.
78. Dartawan, K.; Austria, R.; Le, H.; Suehiro, M. Harmonic issues that limit solar photovoltaic generation on distribution circuits. In Proceedings of the World Renewable Energy Forum, Denver, CO, USA, 13–17 May 2012.
79. Abdurrahman, A.; Zakary, A.; A shazly, A. Simulation and Implementation of Grid-connected Inverters. *Int. J. Comput. Appl.* **2012**, *60*, 41–49.
80. Romero-Caravel, E.; Spagnuolo, G.; Tranquillo, L.G.; Ramos-Puja, C.A.; Santino, T.; Xiao, W.M. Grid-Connected Photovoltaic Generation Plants: Components and Operation. *IEEE Ind. Electron. Mag.* **2013**, *7*, 6–20. [[CrossRef](#)]
81. Koura, S.; Leon, J.I.; Vinnikov, D.; Tranquillo, L.G. Grid-Connected Photovoltaic Systems: An Overview of Recent Research and Emerging PV Converter Technology. *IEEE Ind. Electron. Mag.* **2015**, *9*, 47–61. [[CrossRef](#)]
82. Cagnano, A.; Torelli, F.; Alfonzetti, F.; de Tuglie, E. Can PV plants provide a reactive power ancillary service? A treat offered by an on-line controller. *Renew. Energy* **2011**, *36*, 1047–1052. [[CrossRef](#)]
83. Sousa, J.L.; Brito, C.J.; Fernaldo Pires, V. Impact of Photovoltaic Systems with ancillary services in low voltage grids. In Proceedings of the 15th Biennial Baltic Electronics Conference (BEC2016) Tallinn, Estonia, 3–5 October 2016.
84. Zhong, J.; Bhattacharya, K. Toward a Competitive Market for Reactive Power. *IEEE Trans. Power Syst.* **2002**, *17*, 1206–1215. [[CrossRef](#)]
85. Rosenblatt, F. The perceptron: A probabilistic model for information storage and organization in the brain. *Psychol. Rev.* **1958**, *65*, 386–408. [[CrossRef](#)]
86. Yuce, B.; Li, H.; Rezgüi, Y.; Petri, I.; Jayan, B.; Yang, C. Utilizing artificial neural network to predict energy consumption and thermal comfort level: An indoor swimming pool case study. *Energy Build.* **2014**, *80*, 45–56. [[CrossRef](#)]
87. Kovacic, Z.; Bogdan, S. *Fuzzy Controller Design: Theory and Applications, Volume 19 of Automation and Control Engineering*; CRC Press: Boca Raton, FL, USA, 2006.
88. Radhakrishnan, B.M.; Srinivasan, D. A multi-agent based distributed energy management scheme for smart grid applications. *Energy* **2016**, *103*, 192–204. [[CrossRef](#)]

89. Khare, A.R.; Kumar, B.Y. Multiagent structures in hybrid renewable power system: A review. *J. Renew. Sustain. Energy* **2015**, *7*, 063101. [[CrossRef](#)]
90. Kekatos, V.; Wang, G.; Conejo, A.J.; Giannakis, G.B. Stochastic Reactive Power Management in Microgrids With Renewables. *IEEE Trans. Power Syst.* **2014**, *30*, 3386–3395. [[CrossRef](#)]
91. Gandhi, O.; Zhang, W.; Rodríguez-Gallegos, C.D.; Srinivasan, D.; Reindl, T. Continuous optimization of reactive power from PV and EV in distribution system. In Proceedings of the 2016 IEEE Innovative Smart Grid Technologies—Asia (ISGT-Asia), Melbourne, Australia, 28 November–1 December 2016; pp. 281–287. [[CrossRef](#)]
92. Kumar, D.S.; Srinivasan, D.; Reindl, T. Optimal power scheduling of distributed resources in Smart Grid. In Proceedings of the 2013 IEEE Innovative Smart Grid Technologies-Asia (ISGT Asia), Bangalore, India, 10–13 November 2013; Volume 9, pp. 1–6.
93. Abbasy, A.; Hosseini, S. Ant Colony Optimization-Based Approach to Optimal Reactive Power Dispatch: A Comparison of Various Ant Systems. In Proceedings of the 2007 IEEE Power Engineering Society Conference and Exposition in Africa—Power Africa, Johannesburg, South Africa, 16–20 July 2007; pp. 16–20.
94. Ziadi, Z.; Taira, S.; Oshiro, M.; Funabashi, T. Optimal power scheduling for smart grids considering controllable loads and high penetration of photovoltaic generation. *IEEE Trans. Smart Grid* **2014**, *5*, 2350–2359. [[CrossRef](#)]
95. Demirok, E.; Gonzalez, P.C.; Frederiksen, K.H.B.; Sera, D.; Rodriguez, P.; Teodorescu, R. Local Reactive Power Control Methods for Overvoltage Prevention of Distributed Solar Inverters in Low-Voltage Grids. *IEEE J. Photovolt.* **2011**, *1*, 174–182. [[CrossRef](#)]
96. Alkaabi, S.; Zeineldin, H.; Khadkikar, V. Short-Term Reactive Power Planning to Minimize Cost of Energy Losses Considering PV Systems. *IEEE Trans. Smart Grid* **2018**, *10*, 2923–2935.
97. Rahman, S.; Meraj, M.; Iqbal, A.; Ben-Brahim, L.; Alammari, R. Thyristor based SVC and multilevel qZSI for Active and Reactive power management in solar PV system. In Proceedings of the 2017 11th IEEE International Conference on Compatibility, Power Electronics and Power Engineering (CPE-POWERENG), Cadiz, Spain, 4–6 April 2017; pp. 528–533. [[CrossRef](#)]
98. Wang, T.; O'Neill, D.; Kamath, H. Dynamic Control and Optimization of Distributed Energy Resources in a Microgrid. *IEEE Trans. Smart Grid* **2015**, *6*, 2884–2894. [[CrossRef](#)]



© 2019 by the authors. Licensee MDPI, Basel, Switzerland. This article is an open access article distributed under the terms and conditions of the Creative Commons Attribution (CC BY) license (<http://creativecommons.org/licenses/by/4.0/>).