

Cryostat and CCD for MEGARA at GTC

Castillo-Domínguez, E.^a, Ferrusca Rodríguez, D.^a, Tulloch, S.^b, Velázquez, M.^a, Carrasco E.^a, Gallego, J.^c, Gil de Paz, A.^c, Sánchez, F.M.^d, Vílchez, J.M.^e & MEGARA Team

^aInstituto Nacional de Astrofísica, Óptica y Electrónica, A.P.51 y 216, Puebla, México

^bFRACTAL SLNE, C/ Tulipán 2 Portal 13 1A, 28231, Las Rozas, Madrid, Spain

^cUniversidad Complutense de Madrid, ^dUniversidad Politécnica de Madrid, ^eInstituto de Astrofísica de Andalucía

ABSTRACT

MEGARA (Multi-Espectrógrafo en GTC de Alta Resolución para Astronomía) is the new integral field unit (IFU) and multi-object spectrograph (MOS) instrument for the GTC. The spectrograph subsystems include the pseudo-slit, the shutter, the collimator with a focusing mechanism, pupil elements on a volume phase holographic grating (VPH) wheel and the camera joined to the cryostat through the last lens, with a CCD detector inside.

In this paper we describe the full preliminary design of the cryostat which will harbor the CCD detector for the spectrograph. The selected cryogenic device is an LN₂ open-cycle cryostat which has been designed by the “Astronomical Instrumentation Lab for Millimeter Wavelengths” at INAOE. A complete description of the cryostat main body and CCD head is presented as well as all the vacuum and temperature sub-systems to operate it. The CCD is surrounded by a radiation shield to improve its performance and is placed in a custom made mechanical mounting which will allow physical adjustments for alignment with the spectrograph camera. The 4k x 4k pixel CCD231 is our selection for the cryogenically cooled detector of MEGARA. The characteristics of this CCD, the internal cryostat cabling and CCD controller hardware are discussed. Finally, static structural finite element modeling and thermal analysis results are shown to validate the cryostat model.

Keywords: MEGARA, Cryostat, CCD231

1. INTRODUCTION

MEGARA (*Multi-Espectrógrafo en GTC de Alta Resolución para Astronomía*)^{1, 2} is an optical IFU and MOS designed for the GTC 10.4m telescope in La Palma. MEGARA offers two IFU-type modes with two different bundles, one covering 14 arcsec x 12 arcsec with a spaxel size of 0.685 arcsec (Large Compact Bundle; LCB, which makes use of 100 μ m-core optical fibers) and another one covering 10 arcsec x 8 arcsec with a spaxel size of 0.480 arcsec (Small Compact Bundle; SCB, with 70 μ m-core fibers). The MEGARA MOS mode will allow observing up to 100 objects in a region of 3.5 arcmin x 3.5 arcmin around the two IFU bundles. Both the LCB IFU and MOS capabilities of MEGARA will provide intermediate-to-high spectral resolutions ($R_{FWHM} \sim 6,250, 11,000$ and $19,100$). When the SCB is used the resolving powers provided by MEGARA are $R_{FWHM} \sim 8,100, 14,400$ and $24,700$.

MEGARA Spectrograph has a fully refractive optical system. It has a pseudo-slit, where fibers are placed simulating a long slit 119mm length. Following the light path we find then the collimator which is composed by 1 singlet and 2 doublets, a slit shutter is placed beyond the first collimator lens. The pupil is the location for the VPH-gratings; once the beam passes through the grating it goes to the camera, composed by 2 doublets and 3 singlets, being the last lens the cryostat window and finally focuses on the detector.

In the following sections we describe the different subsections that integrate the custom made design of the MEGARA cryostat³ which fulfills technical and physical requirements of the spectrograph and the location of the instrument itself at the Nasmyth platform at the telescope.

2. CRYOSTAT DESIGN AND DESCRIPTION

Liquid nitrogen (LN₂) cryostat design was proposed as the container for the MEGARA CCD to operate at cryogenic temperatures. Cryostat mounting is horizontal and it is designed to be kept static, as well as all the MEGARA

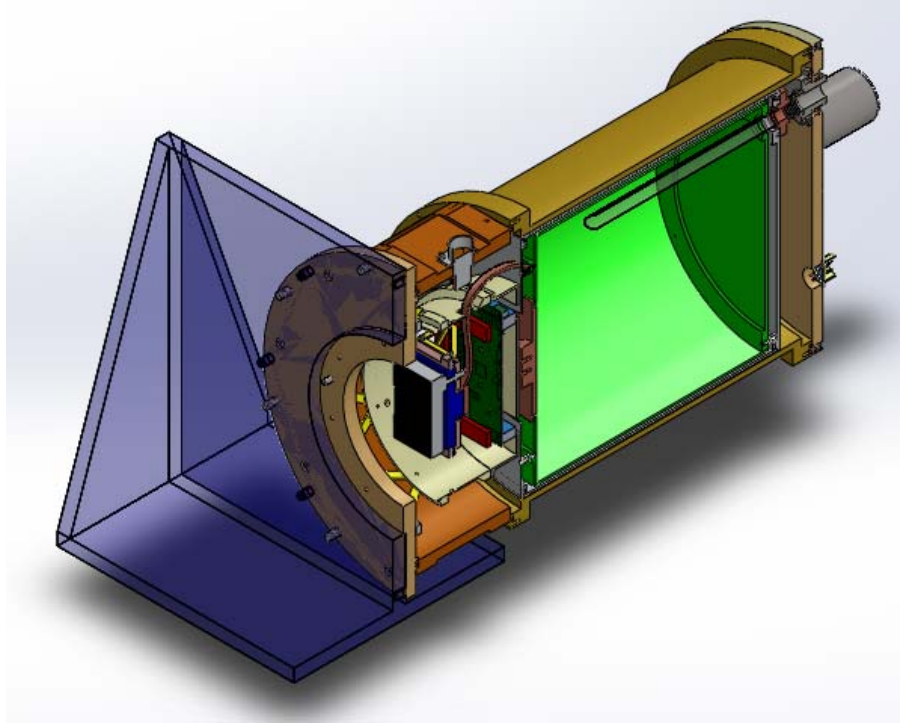

Figure 1. LN2 cryostat main body and CCD head support 3D model (cross section view). The right side of the image shows the vacuum jacket containing in the inside the LN2 tank and its filling tube; on the left side is the CCD head which contains the CCD, its mountings, copper strap, G10 supports, and PCB for electronics.

components. We divided the cryogenic system in two main parts: *i) Dewar main body* which provides the vacuum chamber and the space to contain the LN2 tank; *ii) CCD head* is the mechanical support of the CCD attached to the main body of the cryostat and contains all the associated electronics and hermetic feedthroughs for the read-out cabling. These components are described on the following subsections.

2.1 Dewar main body

Main body serves as vacuum jacket and contains the liquid nitrogen tank; it also has on the rear part the liquid nitrogen fill tube, an electrical port for temperature monitor and two vacuum ports. Aluminum has been selected as the primary material for the vacuum jackets which offers a good structural choice and very low degassing rate. LN2 tank will be made of stainless steel which offers a good thermal behavior when cooling down and will be surrounded by an aluminum radiation shield and MLI super-insulation maybe used to increase the performance of the device. The filling tube has a bellow system which helps to reduce thermal loading on the cryogenes. Cold plate will be made of gold plated OFHC copper to increase thermal conductivity.

The cryostat has a 6.96 liter LN2 tank made of stainless steel (6 liters usable), the consumption it is expected to be at least ~ 3.4 liter/day. The radiation shield will be fabricated from aluminum 6061 and will be highly polished to improve its reflectivity. It will be operated at intermediate temperature between room temperature (through the vacuum jacket) and the liquid nitrogen tank by a weak thermal link and it will be supported in the front and back sides by a set of G10 rods and aluminum mountings.

The main body of the cryostat is cylindrical whilst the CCD head support is cylindrical with flat faces around it to allow easy mounting of electrical connectors and other type of ports. The maximum diameter and length of the complete assembled cryogenic open-cycle system is 270 mm and 385 mm respectively. The mass is ~ 17 kg without LN2.

It is expected to operate the cryostat at high-vacuum levels ($\leq 10^{-4}$ mbar) in order to maximize the LN2 hold time. The cryostat will be equipped with a sorption pump filled with activated charcoal which is activated at cryogenic temperatures and has a huge surface/volume ratio (typically ~ 700 m²/cm³), this device will help to reach the ultimate vacuum level and maintain it during its operation.

The dewar has two CFF vacuum ports: one is used together with a right-angle solenoid operated valve to do the vacuum inside the cryostat whilst the other port is for connecting a vacuum measurement device. Vacuum sensor can be read by using a vacuum gauge controller and then send these signals to the general signal reading interface of MEGARA. Figure 1 shows a 3D model of the cryostat main body with all these components included.

2.2 CCD head

The CCD mechanical head support is attached to cryostat main body. This stage will support the CCD and any associated electronics as well as all the necessary cabling to redistribute the CCD signals from the flex cables (see figure 2) to the hermetic connectors. The CCD support will make the thermal link with the LN2 vessel through a high purity copper strap. The CCD head support is designed to allow easy de-attachment from the cryostat main body thus allowing independent tests, inspection or replacement of components of this section without the necessity of carrying the complete cryostat. Figure 1 also shows the 3D model of the CCD head concept.

On the lid of the CCD head it will be mounted the last lens of the MEGARA spectrograph; consequently it will act as a vacuum window. The external parts (body and lids) of the CCD head serve as a vacuum jacket for the cryostat and they are vacuum assured by using O-rings. The front side allows interfacing with the optical barrel of the spectrograph thus completing the optical path proposed in the overall spectrograph optical design.

The CCD and mountings inside this mechanical support are kept in its position by G10 supports, which have very low thermal conductivity. The CCD is mounted directly over an aluminum plate to allow good thermal conductivity with the copper strap thermal link connected to the bath temperature, while the weight in the CCD mounting is kept reduced to avoid bending or stress at G-10 supports; finally the metallic plate is located on top of a G10 plate. The operating temperature is initially trimmed by adjustments to the length and width of the thermal strap linking CCD and LN2 tank. During operation the CCD temperature is then regulated using a heater resistor. Behind the detector mounting there is enough room to hold a printed circuit board (PCB) to connect the CCD flex cables and redistribute the cabling from the detector to the hermetic connectors located on the vacuum jacket.

The radiation shield will be highly polished aluminum 6061 and it is used to cover the CCD and its mountings in order to improve the cryostat hold time and to keep the adequate operation temperature of the CCD electronics. The assembly consists of two parts: *i) A main body*, which is a cylinder attached to the vacuum lid of the CCD head by means of G10 supports and *ii) A back lid*; both pieces attach together. The radiation shield main body will have an access hole where the thermal link will go through, and the lid will have two exit ports for electrical connectors. Radiation shield will serve also as support for mounting the necessary G10 structures to hold the CCD and its metallic mounting as well as the CCD PCB.

Rectangular metallic mounting plate will be held by G10 lateral supports on the four edges, these supports will be attached to a metallic circular ring that will be connected to the radiation shield main structure. The use of G10 (garolite) allows floating the detector so its temperature can be adjusted by the copper thermal link. The proposed G10 lateral supports and the metallic ring where they are attached will provide enough stiffness to hold the CCD in the desired orientation (cryostat horizontal by requirement). A secondary purpose of the metallic ring is to provide four posts to hold the PCB. The CCD mounting plate is directly connected to an adjustable mechanism that allows to correct in X,Y, Z, tip and tilt.

3. CCD 231-84

We have chosen the E2V technologies CCD231-84-0-E74 as the detector⁴ for the MEGARA instrument. This device uses deep-depletion Silicon to maximize red-end quantum efficiency and minimize fringing. It uses an astro multi-2 coating that gives >90% quantum efficiency between 400 and 770nm. The device comes in a SiC package and is mounted onto the baseplate via three M4 studs. This ensures good thermal contact. Crucially, the distance between the active Silicon and the base of the CCD package is specified to +/-10µm. This greatly aids the assembly of the camera given that the separation of the CCD and the active cryostat window is tightly constrained if optical quality is to be maintained. The CCD has 4k x 4k 15µm pixels and has a low noise amplifier at each corner. We intend to use a diametrically opposed pair of these amplifiers to achieve a 40s readout at < 3e- noise whilst minimizing cross talk within the device.



Figure 2. The CCD231-84 detector showing the two low-thermal-conductivity flex ribbons.

3.1 Electronics readout

The CCD controller will be mounted some 30cm from the detector cryostat. Some additional electronics will be placed within the cryostat vessel to simplify the cabling but primarily to provide anti-static protection. The electronics will take the form of a 110 x 98mm 4-layer printed circuit board (PCB). For protection, all CMOS gates on the CCD are connected to the substrate via 100 K resistors and also through active-clamp SP720 integrated circuits. Connections to the CCD output transistor, dump and reset transistor drains are connected to ground via Zener diodes. The PCB has two connectors that mate directly to the CCD flex-ribbons. Signals from these ribbons are commoned up where possible and routed to a 51-way Glenair micro-D connector. A single cable bundle then leads from this micro-D to a hermetic connector on the cryostat wall. The PCB also contains an LED that can be used for calibration measurements and a Pt100 temperature sensor. The SP720 integrated circuit is only specified down to 233K and for this reason the PCB sits within its own radiation shield to prevent the high-emissivity circuitry from cooling excessively. This Pt100 sensor then allows us to confirm our thermal design. The board also contains removable links that disconnect the Zener diodes. This is necessary during the optimization phase of the instrument when we intend to use diode-mode quantum efficiency measurements. The Zener diodes have high reverse leakage currents that would otherwise divert the photo-current generated by the CCD in these diode-mode measurements. The PCB contains no pre-amplification circuitry. It is not needed given the short length of cabling between CCD and controller.

3.2 Temperature control

The temperature servo system will use a Lakeshore Model 336 Temperature Controller. This is a stand alone unit capable of reading 4 temperature channels and supplying servoed heater power to two separate outputs. Its two heater output channels are capable of supplying 100W. The cable between Lakeshore and cryostat will therefore be fused to avoid the risk of damaging the CCD through excessive heating. The temperature sensor will be the Lakeshore PT-103-AM device which is a Pt100 sensor. The heater used to servo the CCD will be a 50 Ω power resistor mounted in a TO220 package and screwed directly to the CCD baseplate close to the CCD itself. There will be a small thermal differential between the CCD and its baseplate due to the thermal resistance introduced by the SiC and Invar mounting points. This thermal step will be analysed by mounting a Pt100 sensor on the back of the engineering sensor that we intend to buy together with the final science CCD. The radiative load on the CCD will be 1.6W. Conductive and dissipative loads will add a further 400mW approximately. The thermal resistance between CCD and LN2 reservoir will be adjusted so that when servoing at the operational temperature of 158K the heater resistor does not dissipate more than 200mW. This will maximise LN2 hold time whilst ensuring a reasonably fast (4-5 hour) cool-down time. It will be necessary to mount the temperature controller some 4m from the CCD cryostat. Tests have already been done, using a shielded cable between Lakeshore 336 and Pt100 sensor, to demonstrate that temperature accuracy is not compromised. The Lakeshore can be programmed to account for lead resistances and the shielding of the cable maintains the precision of the temperature

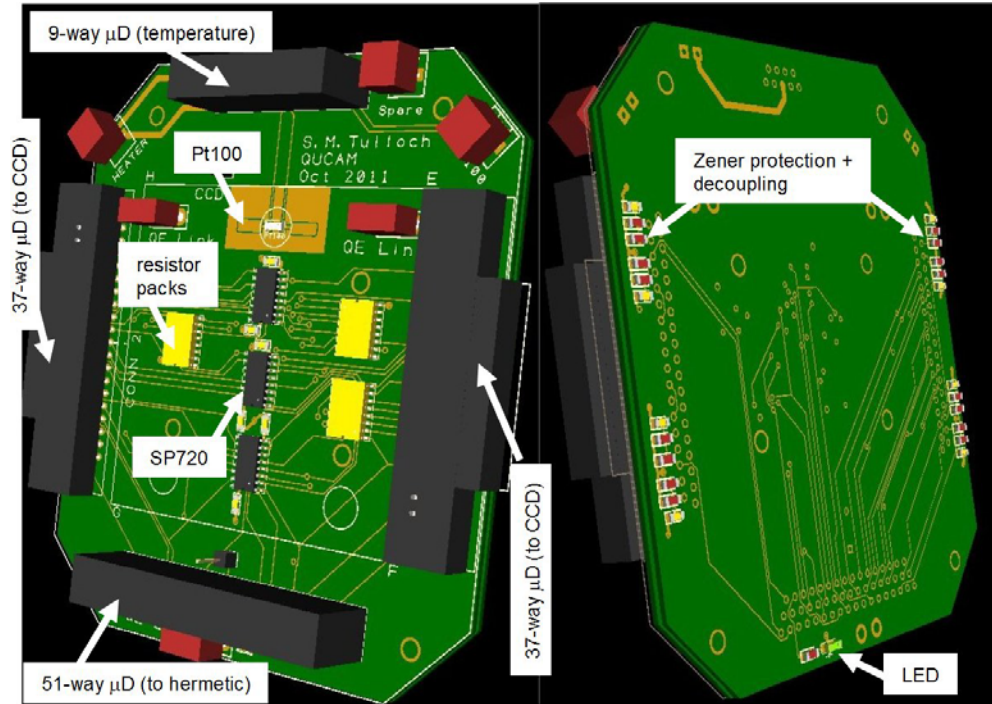

Figure 3. The printed circuit board (front and back) that will be placed within the camera cryostat to protect the CCD.

readings at 10mK. One of the additional temperature input channels will be utilised to monitor the LN2 tank temperature in order to give pre-warning of it boiling dry. Another will be used to monitor PCB temperature, as described in the previous section. The final sensor will be used to monitor the Getter temperature when it is being heated during its reactivation cycle. At 158K the CCD dark current will be below $2e^-$ per hour. The servo stability of the Lakeshore, which in the lab is well below 0.1K, will thus be more than sufficient to maintain dark current stability.

The Lakeshore 336 comes with an Ethernet interface allowing all temperature data and servo power levels to be read across the network. Servo parameters can also be programmed across the network although in the MEGARA instrument we intend to restrict reprogramming access to the front panel buttons only. Temperature servo data will be read by the detector data acquisition system and included in the image file headers. This could provide a useful diagnostic should the cryostat encounter thermal or vacuum related problems during operation.

4. CRYOSTAT MODELING AND DESIGN VALIDATION

A full 3D model of the cryostat was developed for visualization, development of manufacturing drawings and design validation purposes. Through assignation of physical characteristics to all pieces of the model or sub-models we were able to simulate its behavior with certain initial conditions such as fix parts, materials, direction of gravity vector, temperature, etc., as a result of these characteristics some parameters of the pieces, as their weight, volume or deformations can be computed and displayed. Figure 4 shows an exploded view of the CCD head with the main subassemblies and the simplified model used for the static and vibrations analysis which includes the front lid, CCD mounting structure and CCD housing.

Besides the weight calculation, other advantage of the addition of physical characteristics to the 3D model is the conversion of a simple 3D model into a real physical model. The physical model can be used to calculate the behavior of the system under normal operation conditions or to know the operative limits before failure. The CCD head system has three critical parameters: the first is how much the CCD is bending down its supporting structure under the gravity influence, the second is how the system responds to mechanical vibration and the third is the thermal behavior of the CCD and PCB stages. The results of these calculations are described in the next subsections.

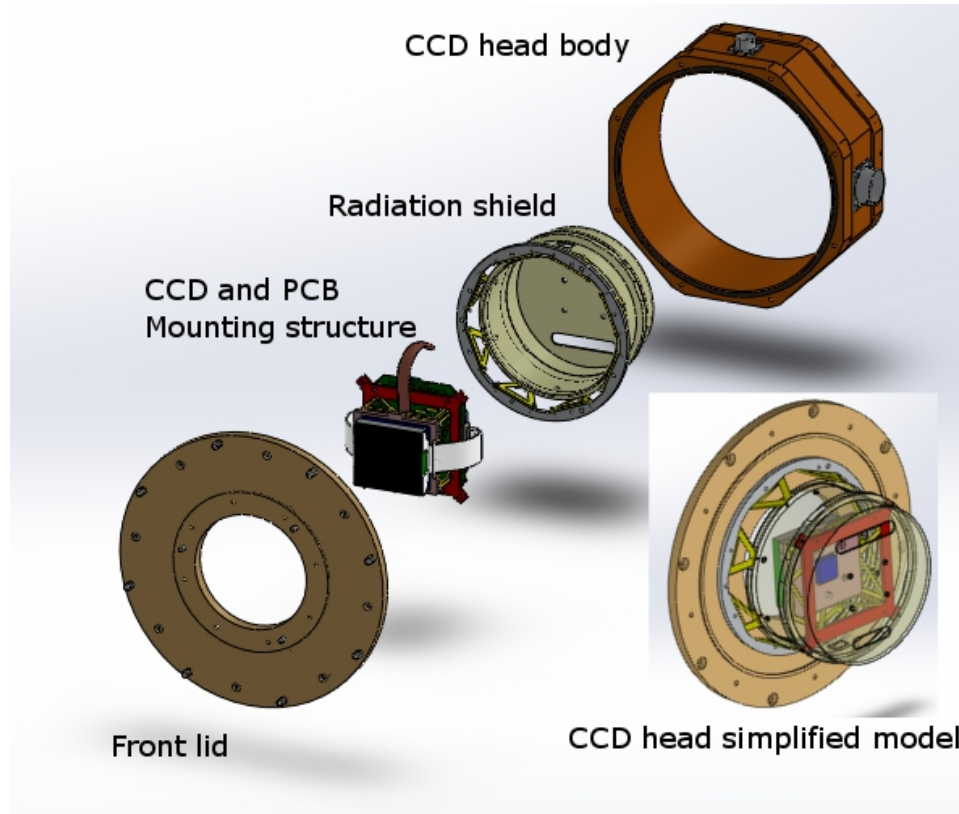

Figure 4. Explode view of the CCD head main components. At the right bottom is shown the simplified version of the model used for vibration and thermal analysis. Material, weight and mechanical properties of the materials were used in the FEA modeling.

4.1 Static analysis

The static analysis was performed with finite element analysis (FEA) for three reasons: *i*) Displacement of CCD out of defined tolerances (7.5 microns, half of pixel size); *ii*) displacement of the CCD or the CCD base larger than the gap between them and the radiation shield, this will bring a thermal short circuit, if this occurs the temperature and hold time will be compromised; *iii*) finally the last reason is the breaking possibility of some of the structural element under the CCD weight. These analyses allow us to find any possible major displacement in the support structure and develop solutions.

The mechanical FEA includes meshing the 3D model, which can be appreciated in figure 5, the selected shape for the mesh procedure is curved, and the whole model is affected by gravity. Gravity vector is defined opposite to the Y direction, and the front lid is the only part which is fixed in the analysis.

The results of the static analysis are mainly two: stress and displacement parameters. In figure 6 we show a typical result of displacement in the CCD head when is affected by gravity. It can be seen that the displacement result is about 2 microns. Stress results shows that the maximum value is 0.8 N/mm^2 (for the materials used in the CCD head). These results prove the feasibility of the proposed design, including geometries and selected materials.

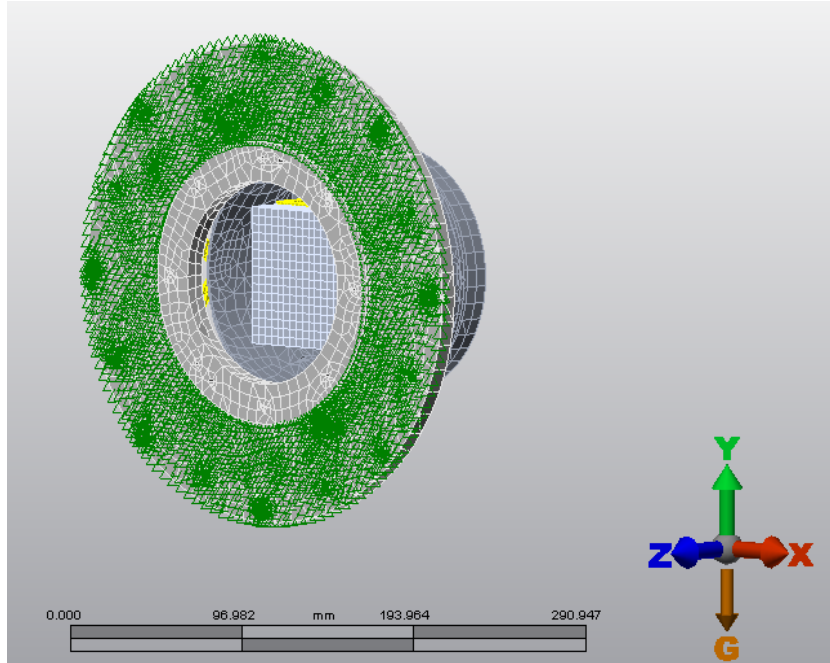

Figure 5: Front view of the meshed CCD head assembly of the MEGARA cryostat analyzed with FEA. Front lid flange is kept fixed, whilst the other parts are affected by gravity load (orange vector 'G').

4.2 Vibration analysis

Two main motivations were taken into account to perform the vibration analysis: the possible breakage of any structural component due resonance and the PSF degradation. The first one is self-explanatory, if the CCD supporting structure resonates, there is a large chance of stress increase until the component breaks, which can become a thermal short circuit or damage the detector; another possibility is an extreme bending causing intermittent thermal short circuit, which can degrade the hold time of the cryostat and may alter the CCD temperature, this issue can be difficult to find due its intermittent nature. The second one is the degradation of the PSF due the change of position of the detector pixels. The extreme result could be the blending of adjacent lines or/and adjacent spectra depending on the vibration axis.

Table 1. Summary of results from vibration analysis. Six modal frequencies that affect the CCD head assembly are shown.

Mode number	Frequency (Hertz)	Period (sec)
1	3.8E2	2.6E-3
2	3.9E2	2.6E-3
3	6.1E2	1.6E-3
4	8.1E2	1.2E-3
5	8.2E2	1.2E-3
6	8.2E2	1.2E-3

In order to have a complete vibration analysis two finite element analyses are necessary. The first calculation is the modal analysis (study of the dynamic properties of structure under vibrational excitation) and the second one is the response spectrum which needs the results of the first analysis and a mechanical vibration measurement of the place where the system under study will be installed. The results of this last calculation are the displacements on each axis. The MEGARA spectrograph is going to be stationary at the Nasmyth (or the sub-Nasmyth) platform on the telescope, estimations of mechanical vibrations at GTC telescope might be necessary to conclude this study; however modal frequencies results (see table 1) suggest that the proposed CCD mounting structure is safe to keep stable the detector.

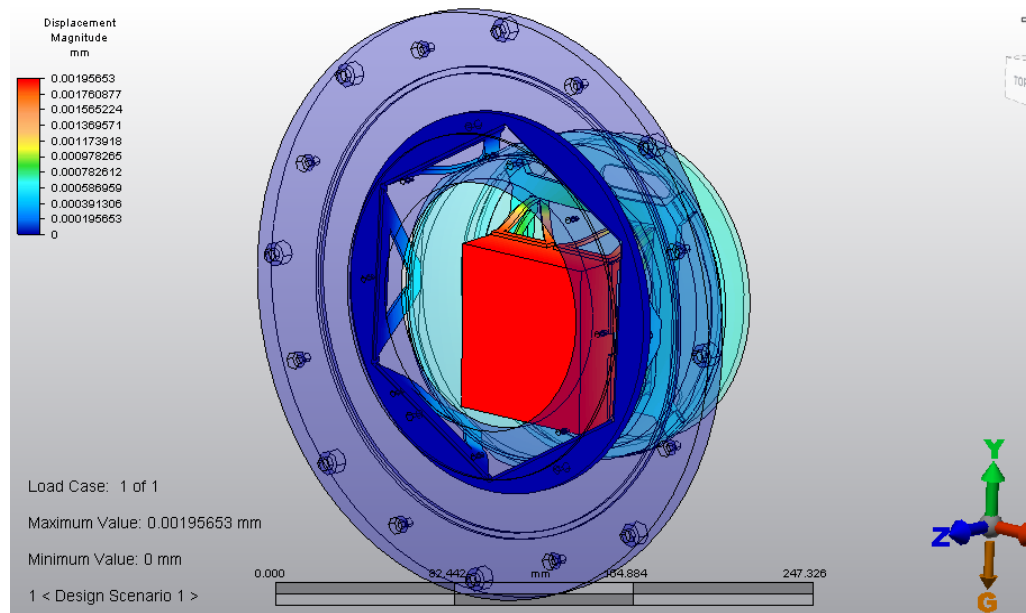

Figure 6. Total displacement analysis plot from X, Y, Z contributions. The maximum displacement is located in the CCD and the value is 2 microns, this displacement is not significant due the pixel size is 15 micron.

4.3 Thermal analysis

Heat transfer is a critical stage in cryogenic designs. The analysis considered for the MEGARA cryostat includes conductive heat transfer through solids and radiative heat transfer through space. Conductive heat transfer can be predicted very well and theory can be found elsewhere⁵, whilst radiative transfer analysis can give us reasonable estimates. The challenge is variability among materials, handbook values of the surface emissivity for radiation can differ significantly from material to material, depending on surface texture, tarnish, and so on.

Values of thermal conductivity $\lambda(T)$ for typical cryostat materials can be found in the literature⁶, covering a wide range of over six orders of magnitude depending on the material. Because of the strong temperature dependence of $\lambda(T)$, cryostat design can be simplified with general tabulations of the thermal conductivity integral. Most of the handbooks values of thermal conductivity or the integrals do not vary much among different samples of the same material, except for high-purity metals. The conductivity of a pure metal at low temperatures varies all over the map depending on their defect content.

The radiative transfer of heat into the test section of the cryostat can be significant because of the great difference in temperature between the various parts of the cryostat; this thermal contribution can be calculated by the Stephan-Boltzmann equation⁵. To minimize these effects radiation shields are inserted between hot and cold surfaces to intercept the heat flow. Radiative heat transfer strongly depends on the surfaces' emissivity which can varies from values near the unity for heavily oxidized surfaces to low values approaching zero for polished metallic surfaces. The emissivity of highly polished, highly conducting metallic surfaces (such as those of Ag, Cu, Au and Al) are very low, about 0.01 to 0.03 (that is, they are highly reflecting and excellent materials for radiation shields).

According to the theory described before, figure 7 shows the schematic thermal model used in the MEGARA cryostat whilst table 2 shows the results obtained from thermal analysis.

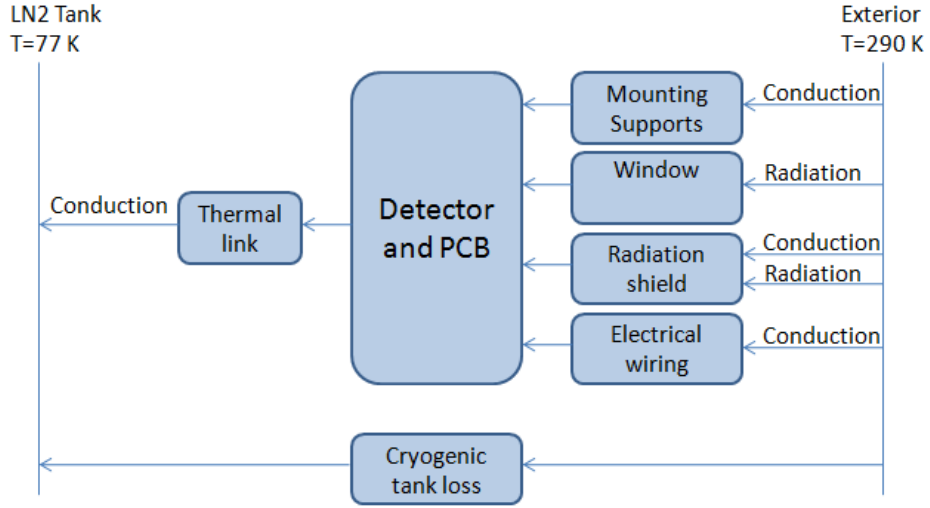

Figure 7. Simplified thermal model for the CCD-head of MEGARA cryostat. Detector and PCB are placed in its own supports.

Table 2: Main parameters obtained from thermal modeling for open-cycle MEGARA cryostat

Parameter	Total value	Units
Copper braid thermal link (6 braids) thermal conductance	48×10^{-3}	W/K
G10 CCD legs (8)	2.6×10^{-3}	W/K
G10 Radiation shield legs (4)	4.2×10^{-3}	W/K
Nylon PCB legs (4)	2.1×10^{-3}	W/K
CCD equilibrium temperature	154	K
CCD Radiation shield equilibrium temperature	256	K
PCB equilibrium temperature	235	K
Copper braid dissipated power	3.7	W
LN2 Radiation shield equilibrium temp	250	K
LN2 tank absorbed radiation heat	1.2	W
LN2 tank hold time	45.5	Hours

5. CONCLUSIONS

An open-cycle cryostat using liquid nitrogen has been chosen as the cryogenic device to maintain the CCD detector at the operating temperature of ~ 158 K for the MEGARA spectrograph. Main parameters considered in this decision include:

- Feasibility of fabrication and use of proven technologies.
- Risks can be overcome by using good design practices, which include simulations and finite element models, as well as experimental tests of critical parts.
- Low-cost of fabrication for cryostats in the MEGARA overall long term plan.
- Current facilities at GTC can be used without the need of modifications or special requirements.

- Current technicians and telescope staff can operate the cryostat without the need of specialized training.
- All the vacuum and thermometry accessories are commercial and standard for this type of purposes thus can be found easily and costs are reduced.

MEGARA LN2 cryostat design fulfills all the technical requirements, can be designed, tested and fabricated within the timescale defined by the GTC for the MEGARA project, and it fits the budget for the two different scenarios (MEGARA-Basic and MEGARA-Advanced) proposed.

On the other hand the MEGARA cryogenic system uses the E2V CCD231-84-0-E74 which is the highest performance 4k x 4k CCD available, in terms of QE, noise, mechanical flatness and suitability of packaging. The CCD is specified "grade 0" (the highest available) which means it is guaranteed to have less than 5 defective columns but typically has none. Read out noise is claimed to be 2e- at 50kpix s-1 and 3e- at the proposed MEGARA read-out speed of 300kpix s-1. The CCD is manufactured on deep depletion Silicon in order to minimise fringing and maximise red-end QE. Its full well is 350ke- and CTE in both axes is 0.999995 minimum. The CCD will use the Astro Multi-2 AR coat.

REFERENCES

- [1] Gil de Paz, A, et Al., "MEGARA Preliminary Design: Instrument Overview", TEC/MEG/059 2.B MEGARA consortium internal technical report, 14-18 (2012)
- [2] Gil de Paz, A, et Al., "MEGARA: the future optical IFU and multi-object spectrograph for the 10.4m GTC telescope", Proc. SPIE 8446, (2012).
- [3] Ferrusca, D., Castillo, E., Velázquez, M., et Al., "MEGARA Preliminary Design: Cryostat", TEC/MEG/028 1.D MEGARA consortium internal technical report, 1-50 (2012)
- [4] Tulloch, S., et Al., "MEGARA Preliminary Design: Detector and DAS", TEC/MEG/051 1.D MEGARA consortium internal technical report, 11-39 (2012)
- [5] Ekin, J.W., [Experimental Techniques for Low-Temperature Measurements], Oxford University Press, Oxford & New York, 50-52,55,516 (2006).
- [6] White, G.K., [Experimental Techniques in Low-Temperature Physics], Oxford Science Publications, Oxford & New York, 84-87 (2002).