

## Cycloconverters and cycloconverter-fed drives : A review

AJIT K. CHATTOPADHYAY\*

FIEEE, FNAE, Department of Electrical Engineering, Bengal Engineering College (Deemed University), Howrah-711 103, India.

### Abstract

Significant developments have taken place in control, analysis, modelling and practical implementation aspects of cycloconverters and their applications to the adjustable-speed ac drives. This paper attempts to make a comprehensive and chronological review on the progress of research and industrial development, all over the world, to provide a background information on the present status of cycloconverters and cycloconverter-fed drives. In the process, it highlights the substantial research work done at the Indian Institute of Technology (IIT), Kharagpur towards developing practical control schemes and simulation models for cycloconverter-fed induction and synchronous motor drives.

**Keywords:** Cycloconverters, Drives, Power Electronics, Induction motor drives, Synchronous motor drives.

**Major Discipline:** Electrical Engineering (Adjustable-speed drives).

### 1. Introduction

The cycloconverter is a power-electronic equipment designed to convert constant voltage constant frequency ac power to adjustable voltage adjustable frequency ac power without any intermediate dc link. The basic principle of this converter, conceived and patented by Hazeltine<sup>1</sup> in 1926 is to construct an alternating voltage wave of lower frequency from successive voltage waves of a higher frequency multiphase ac supply by a switching arrangement. Grid-controlled mercury arc rectifiers were used in these converters in 1930's to obtain 1-phase  $16\frac{2}{3}$  Hz supplies for ac traction motors in Germany from a 3-phase 50 Hz system<sup>2</sup> while at the same time a cycloconverter using thyatron<sup>3</sup> for supplying a 400 hp synchronous motor was in operation for some years as a power station auxiliary drive in USA. However, the practical and commercial utilisation of these schemes waited until the thyristors became available in the 1960's. With the availability of large rating SCRs and later the development of microprocessor-based control, the cycloconverter today is a practical proposition in large power applications with synchronous or induction motors like gearless mill drive in cement industry<sup>4-12</sup>, centrifugal pump and compressors<sup>13</sup>, electric traction<sup>14-15</sup>, rolling mills<sup>16-18</sup>, variable-speed constant frequency (VSCF) systems<sup>19</sup>, static Scherbius drives<sup>20-22</sup>, mine winders<sup>23-24</sup>, ship propellers<sup>25</sup> etc.

A cycloconverter is a naturally commutated converter with inherent capability of bidirectional power flow and there is no real limitations on its size which is otherwise restricted in the case of a thyristor inverter due to the size of commutating elements. Here the switching losses are considerably low, the regenerative operation at full power over complete speed range is inherent and it delivers a nearly sinusoidal waveform resulting in minimum torque pulsations and harmonic heating effects. It is capable of operation even with blowing out of individual

\*Formerly with the Department of Electrical Engineering, Indian Institute of Technology, Kharagpur 731 302, India.

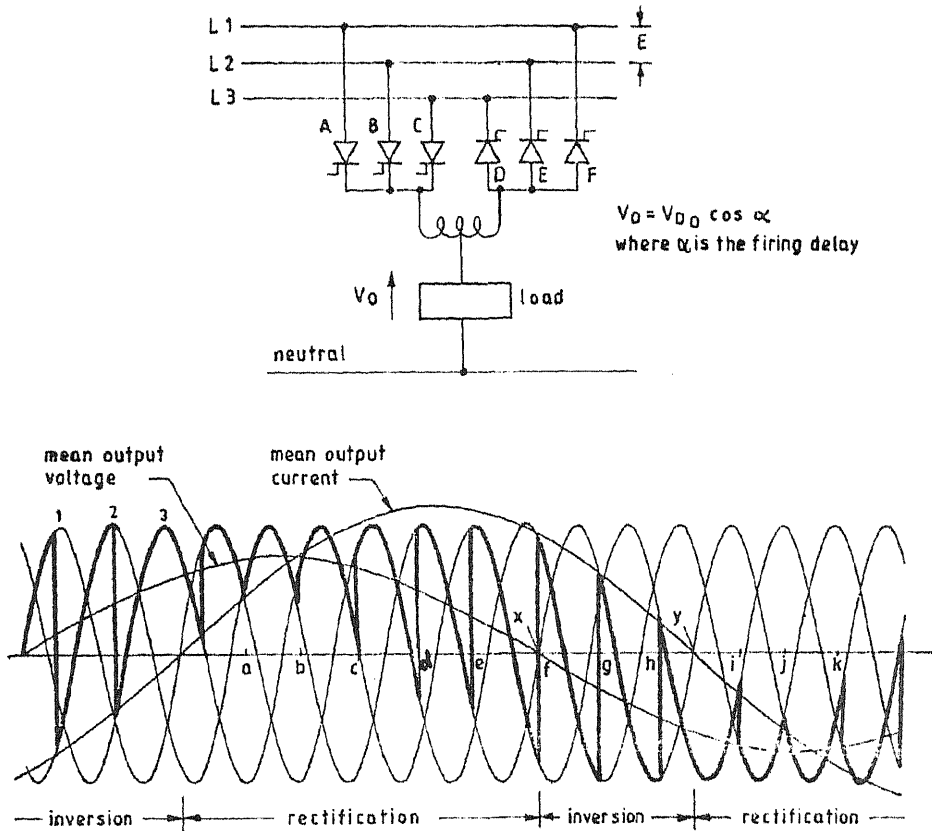

Fig. 1. Output voltage waveform for one phase of a three phase cycloconverter operating at 15 Hz from 50 Hz supply. 0.6 p. f. lagging load<sup>30</sup>.

thyristor fuse (unlike inverter) and the requirements regarding turn-off time, current rise time and  $dv/dt$  sensitivity of thyristors are low. The main limitations of the naturally commutated cycloconverters are (1) limited frequency range (less than half of the input frequency) for sub-harmonic-free and efficient operation and (2) poor input displacement and power factor, particularly at low output voltages. However, with improved control techniques<sup>26-29</sup>, these problems are being overcome.

Significant developments, that have taken place in control, modelling and analysis, and application aspects of cycloconverter drives are focussed in the next few sections here.

## 2. Cycloconverter control

### 2.1. Basic Principle of Operation

The process of cycloconversion is illustrated in Fig. 1<sup>30</sup> for a 3-pulse cycloconverter at 15 Hz, 0.6 p.f. lagging load from 50 Hz supply. As the firing delay angle  $\alpha$  is cycled from zero at 'a' to 180 at 'j', half a cycle of output frequency is produced. For this load, it can be seen that al-

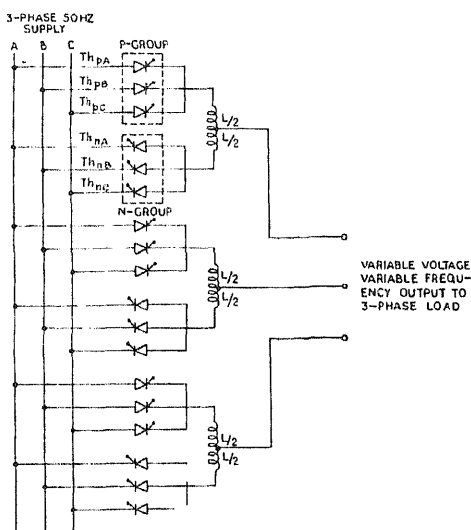

FIG. 2. Three-phase half-wave cycloconverter power circuit.

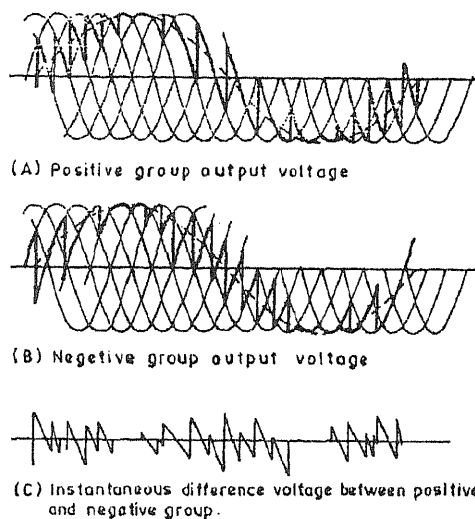

FIG. 3. Voltage waveforms for a six-pulse circulating current cycloconverter.

though the mean output voltage reverses at X, the current (assumed sinusoidal) remains positive until Y. During XY the positive group of rectifier thyristors A,B,C are 'inverting'. A similar period exists at the end of the negative half-cycle of the output voltage when D, E and F thyristors will be 'inverting'. Thus, the operation of the groups follows in the order of 'rectification' and 'inversion' in a cyclic manner, the relative durations being dependent on load p.f. The output frequency is that of the firing delay oscillation about the quiescent point of  $90^\circ$  (condition when the mean output voltage is zero). Actually, the firing angle of each arm of the converter is defined by the time at which a control or reference voltage of output frequency and a modulating voltage of input frequency are identical. Variation of  $\alpha$  within the limits of  $180^\circ$  automatically provides for 'natural' line commutation of the thyristors. The P-group or N-group thyristors (Fig. 2 shows the basic 3-pulse or 3-phase half wave cycloconverter with 18 thyristors with 3 thyristors in each group while use of full-wave 3 phase bridge will need 36 thyristors with 6 thyristors in each group) receive firing pulses which are timed such that each group delivers the same mean terminal voltage. This is achieved by maintaining the firing angle constraints of the two groups as  $\alpha_p = (180^\circ - \alpha_n)$ . However, the instantaneous voltages of the two groups are not identical and large circulating current may result as shown in Fig. 3 for a six pulse cycloconverter unless limited by intergroup reactors (circulating current cycloconverter) or completely suppressed by removing the gate pulses from non-conducting group by intergroup blanking logic (circulating current-free cycloconverter). These developments are concurrent with the similar developments in dual converters for supplying reversing dc motor drives.

## 2.2. Control Schemes: Analog

Various possible analog control schemes for deriving triggering signals for controlling the basic cycloconverter (Fig. 2) as developed in late 60's and early 70's are described in literature<sup>30-40</sup>. It

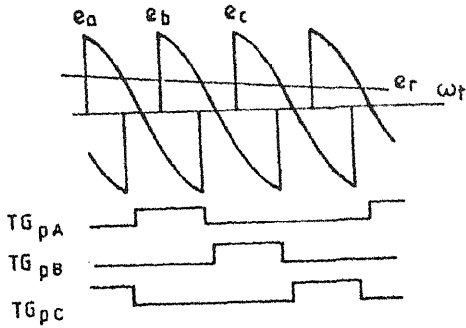

FIG. 4. Deriving firing signals for one group<sup>38</sup>.

has been shown that a cosinusoidal reference signal ( $e_r = E_r \cos \omega_0 t$ ) at desired output frequency  $f_0$  and a cosine modulating signal ( $e_m = E_m \cos \omega_1 t$ ) at input frequency  $f_1$  is the best combination possible to derive the trigger signals (Fig. 4) which produces the output waveform with the lowest total harmonic distortion. The modulating voltages can be obtained as the phase-shifted supply voltages (B-phase voltage for A-phase thyristors, C-phase voltage for B-phase thyristors and so on) as explained in Fig. 5<sup>40</sup>, when the cycloconverter output voltage  $V_o$  can be shown as

$$V_o = V_{d0} \cos \alpha = V_{d0}(E_r / E_m) \sin (\omega_1 t - \phi) \tag{1}$$

which equation shows that the amplitude, frequency and phase of the output voltage can be controlled by controlling the corresponding parameters of the reference voltages, thus making the transfer-characteristic of the cycloconverter linear. The derivation of two complementary voltage waveforms for the P-group and N-group converter 'banks' in this way is illustrated in Fig. 6. The final cycloconverter output waveshape is composed of alternate half-cycle segments of the complementary P-type and N-type output voltage waveforms which coincide with the positive or negative current half cycles.

2.2.1. Typical Control Implementation

Fig. 7 shows a simplified block diagram of the circulating current-free control circuit of the cycloconverter implemented with IC's using cosine control<sup>38</sup> in the early seventies at the

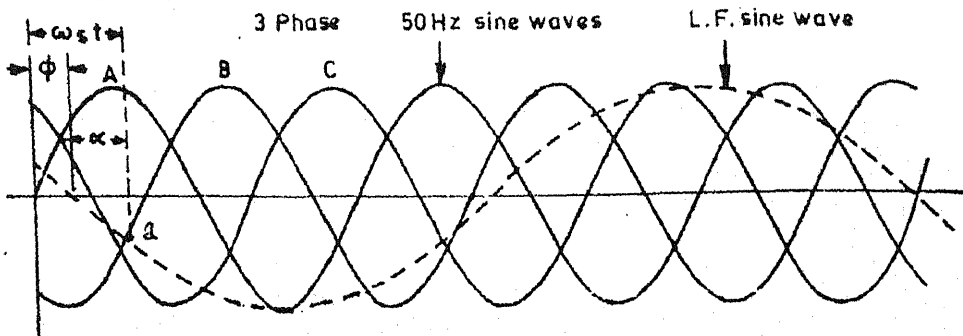

FIG. 5. Derivation of cosine modulating voltages<sup>40</sup>.

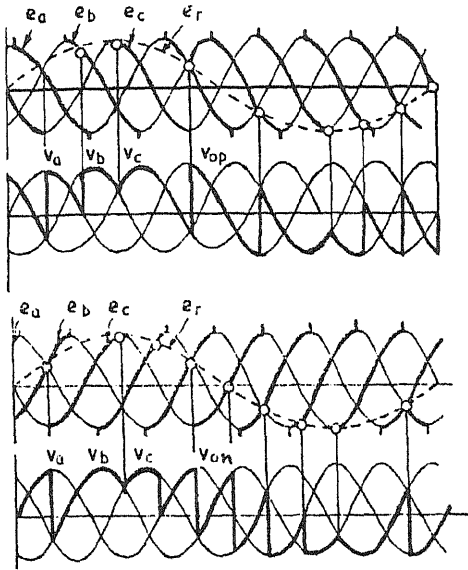

Fig. 6. Derivation of P-group and N-group output voltages.

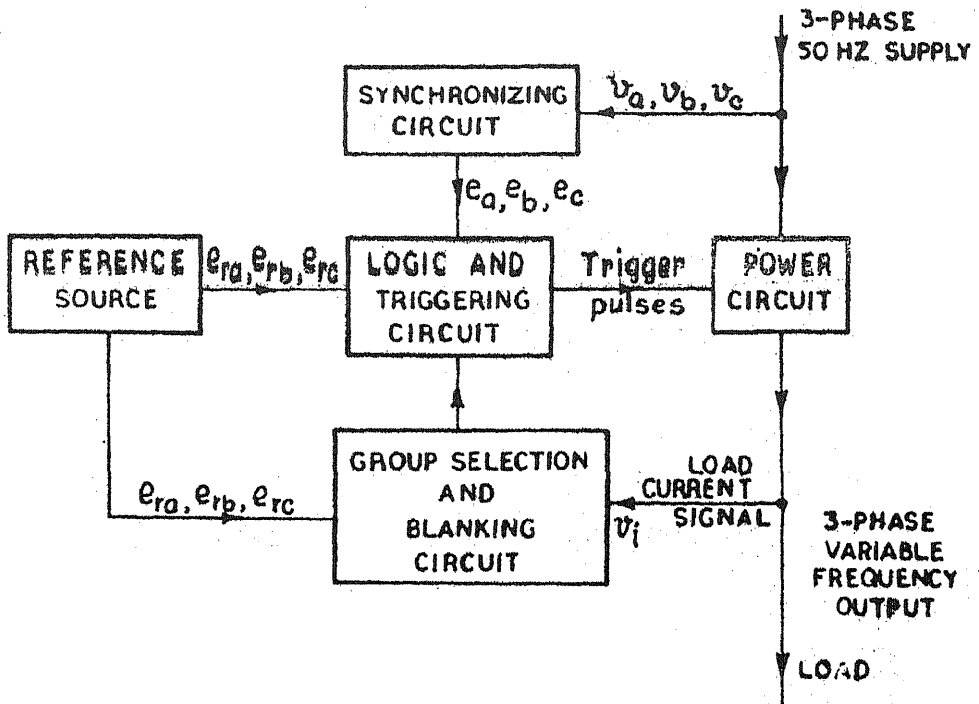

Fig. 7. Block diagram for a circulating current-free cycloconverter control circuit.<sup>38</sup>

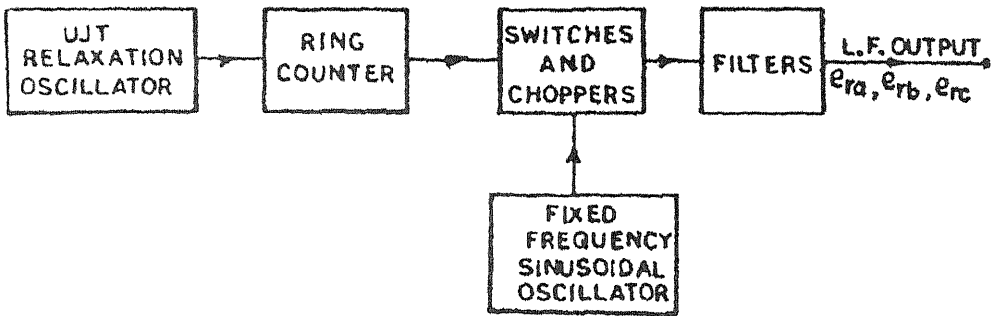

FIG. 8. Block diagram of the variable voltage, variable frequency three phase reference source<sup>38</sup>.

Power Electronics Laboratory in IIT Kharagpur. Out of the various blocks shown, the group selection and blanking circuit is not needed for the circulating current mode operation of the cycloconverter.

The synchronising circuit produces the modulating voltages of the input frequency through step-down transformers. One of the ways of obtaining 3-phase variable voltage variable fre-

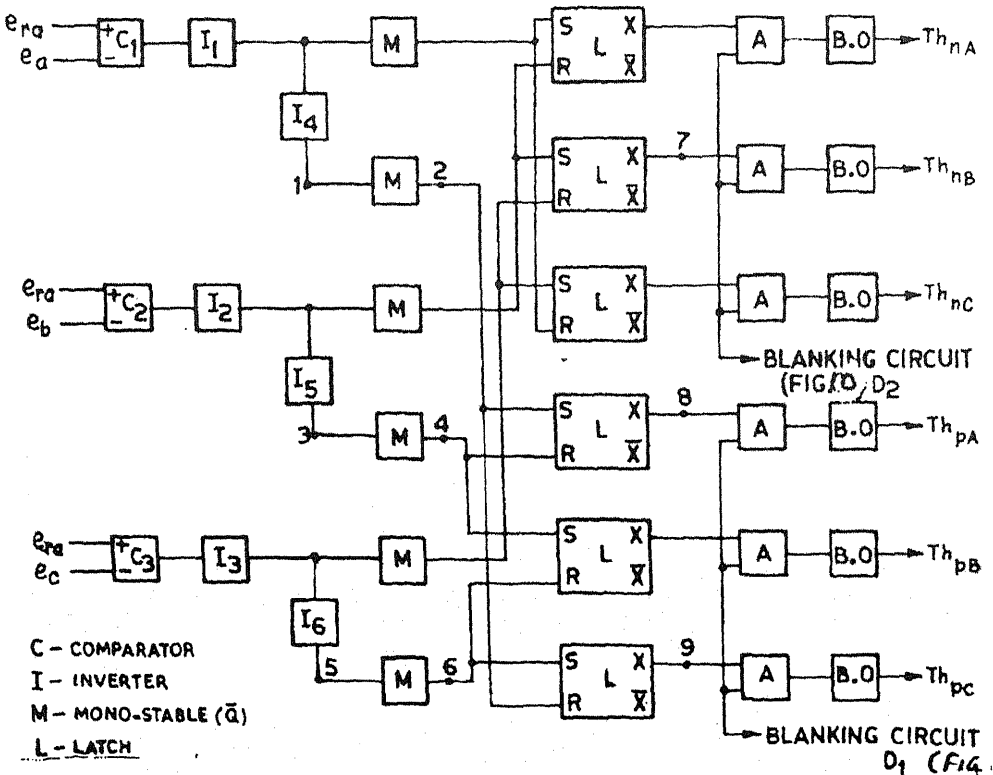

FIG. 9. Block diagram of the main logic and triggering circuit (for phase a of the output only)<sup>38</sup>.

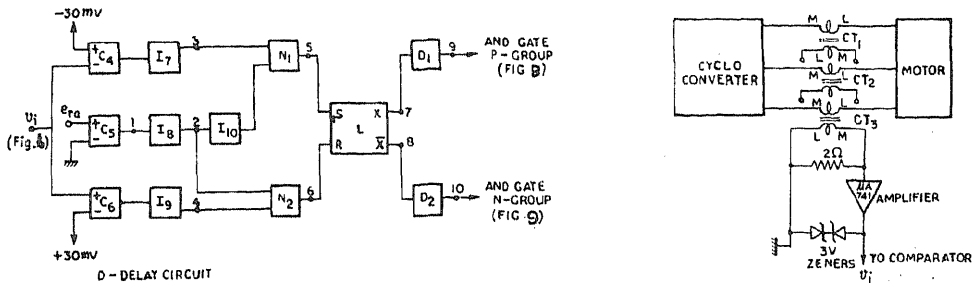

FIG. 10a. Group selection and blanking logic circuit for phase a, b. Current sensing circuit<sup>38</sup>.

frequency reference source using a simple hardware circuit is shown in Fig. 8, when a variable-frequency UJT relaxation oscillator of frequency  $6f_d$  triggers a 3-stage ring counter to produce 3-phase square-wave output of frequency  $f_d$  which is used to modulate a 1-phase fixed frequency ( $f_c$ ) variable amplitude sinusoidal voltage in a 3-phase full-wave transistor chopper. The 3-phase output contains  $(f_c - f_d)$ ,  $(f_c + f_d)$ ,  $(3f_d + f_c)$  etc. frequency components from where the 'wanted' frequency component ( $f_c - f_d$ ) is filtered out by using low pass filters. For example, with  $f_c = 500$  Hz and frequency of the relaxation oscillator varying between 2820 to 3180 Hz, a 3-phase 0-30 Hz reference output can be obtained with the facility for phase-sequence reversal. The block diagram of Fig. 9 shows the main logic and triggering circuits for one of the phases - where comparators are used to compare the reference voltages with modulating voltages and the inverters shown act as buffer stages. Outputs from the latches feed the thyristor gates through AND gates and blocking oscillators, the second input to the AND gates being from the group-selection and blanking circuit. The 'first zero' crossing of the current which may be discontinuous at the end of each half cycle is detected by a current-sensing circuit and processed through the group-selection and blanking circuit (Fig. 10, for one of the phases) where comparators also monitor the reference voltage source apart from load currents to ensure proper group switching. The delay circuits delay the gate signals to the N-group thyristors until the already conducting P-group thyristors are completely off to avoid circulating currents.

Fig. 11 shows typical oscillograms of the output currents of the implemented cycloconverter feeding induction motors at two different frequencies.

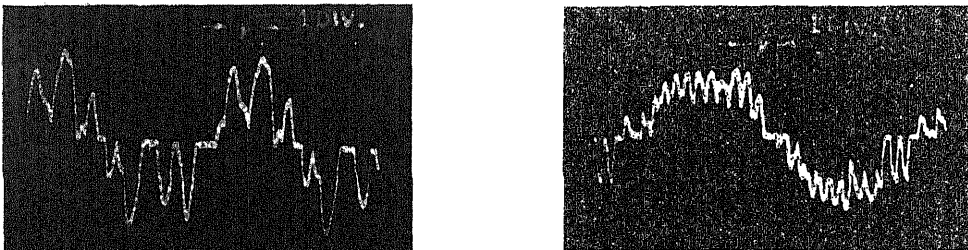

FIG. 11. Typical oscillograms of cycloconverter-fed induction motor current at (a).  $16\frac{2}{3}$  Hz (b) 5 Hz.

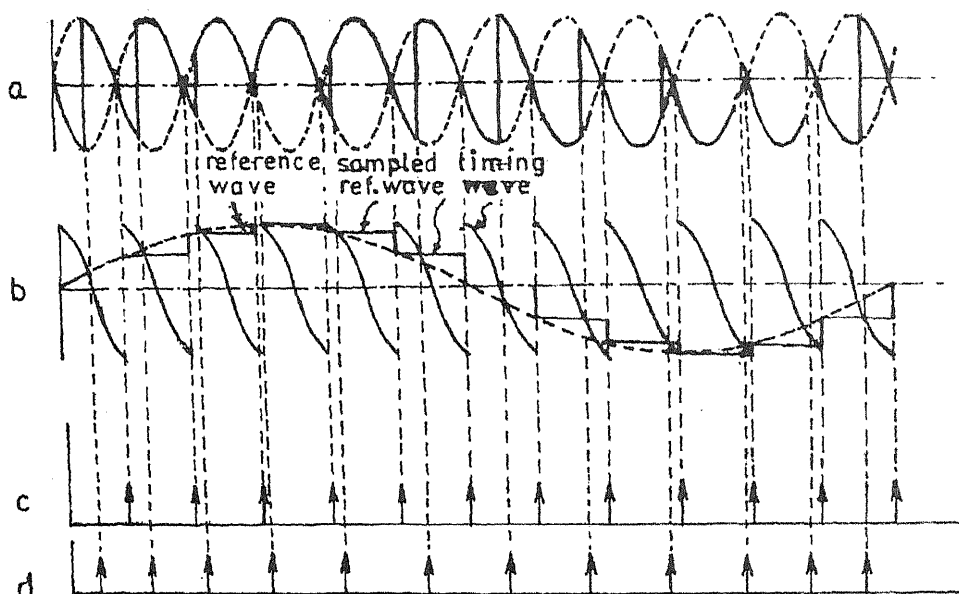

FIG. 12. Cycloconverter operation with regular sampling [26].

### 2.2.2. Improved control schemes

The output voltage of the cycloconverter contains a complex harmonic pattern given by  $k_1 n f_1 \pm k_2 f_2$ , where  $n$  = pulse number and  $k_1$  and  $k_2$  are integers<sup>31</sup>. Although the high frequency harmonics are low with 'cosine wave control', significant subharmonics are produced whose magnitudes are high enough to cause objectionable current in a motor and restrict the output frequency range (e.g., with 50 Hz input frequency and 35 Hz output frequency, a subharmonic of  $3 \times 50 - 4 \times 35 = 10$  Hz is produced whose magnitude is 12.5% of 35 Hz component). Modification of the firing control using communication principles like 'regular sampling' (Fig. 12) in preference to 'natural sampling' (Fig. 4) of the reference voltage waveform before comparison with the cosine wave has been shown<sup>26-27</sup> to reduce the subharmonics with circulating current cycloconverters leading to expansion of the operating frequency range. A microprocessor-based digital cycloconverter control implementing this scheme is reported in<sup>51</sup>. The application of a fast current control loop in circulating current cycloconverters and reducing the non-current delay during cross-over also lead to the increase the output frequency range<sup>28</sup>. Another method to improve performance is to use a 12-pulse cycloconverter using 72 thyristors<sup>47,48</sup> which can be only cost-effective for very large (say, 3 MW) drives.

The generation and synchronisation of low frequency three phase sine-waves over a wide range is a difficult problem and several techniques, analog and digital have been presented in the literature<sup>41,45</sup>. An all digital approach which overcomes the poor frequency stability problems is to use EPROM devices to store a digitized representation of the desired output waveform<sup>45,46</sup>. A recent development is to use a hybrid-firing controlled incorporating both digital and analog methods<sup>46</sup>. Current-zero detection schemes with current transformers may not be



sufficient for very low frequencies. Alternative schemes like continuous monitoring of voltage across each thyristor<sup>37</sup> or conduction state of each SCR series thyristor-diode circuits<sup>6</sup> may simplify the requirements of an accurate bank selection signal for eliminating the need of large interphase reactors.

### 2.3. *Microprocessor-based control schemes*

With the rapid development of microprocessors, software control of cycloconverters has been attempted<sup>49-60</sup> to reduce cost and complexity and increase the accuracy and reliability of the controllers. Early attempt<sup>49</sup> was to directly implement the conventional cosine timing wave approach in connection with sinusoidal reference voltage - in which case it was recognised that the digital comparison of two trigonometric functions as proposed by the numerical technique was too slow to be practical. An efficient algorithm was presented in<sup>51</sup> using regular sampling method with desirable output performance. Experimental arrangement was built around M6800 evaluation kit with MC 6840 timer module and an MC6820 pia unit. There was no need to generate three actual timing waves, nor a continuous reference signal and six channel comparator circuits as in the analog case.

Later developments includes the digital cycloconverter control (DCC) based on the subdivided interval principle<sup>54</sup> where a sinusoidal output voltage is approximated by a stepped waveform to get a suitable amplitude for the mean output voltage at each subdivided interval - the mean value of which was utilised to determine the firing angles. New methods are suggested in<sup>56,59,60</sup> where all the input cosine waves are transferred with a set of parallel lines by means of co-ordinate transformation or a phase plane called a 'time process chart'. The straight line approximations avoid the use of trigonometric or inverse trigonometric functions. Some improvements in implementing cosine wave crossing pulse timing methods in microcomputer-based cycloconverter have been suggested<sup>58</sup> recently.

### 2.4. *PC-based hybrid control scheme*

For a six pulse non-circulating current cycloconverter-fed synchronous motor drive with a vector control scheme and flux observer, a combination of analog and digital control (called hybrid control scheme) has been recently developed at IIT Kharagpur<sup>94</sup>. Here the function such as comparison, group selection, blanking between the groups and the triggering signal generation, filtering and phase conversion are left to the analog controller and the digital controller takes care of more serious tasks like voltage decoupling for current regulation, flux estimation using observer, speed, flux and field current regulators using PI-controllers, position and speed calculation leading to an improvement of sampling time and design accuracy. The scheme as shown in block diagram form in Fig.13 has been implemented with a 386-DX PC based system with 387 support<sup>94</sup>.

## 3. Cycloconverter-controlled induction motor drives

In earlier applications<sup>63</sup>, cycloconverter fed multiple induction motor drives were used to drive hot-strip mill run out table motors. In one installation, 300 motors of 2.6 hp, 212 rpm each were used and the speed range (13-0-13 Hz) with 6 pole was suitable for the application with a 60 Hz system. Individual induction motor drive for high performance servo applications with in-

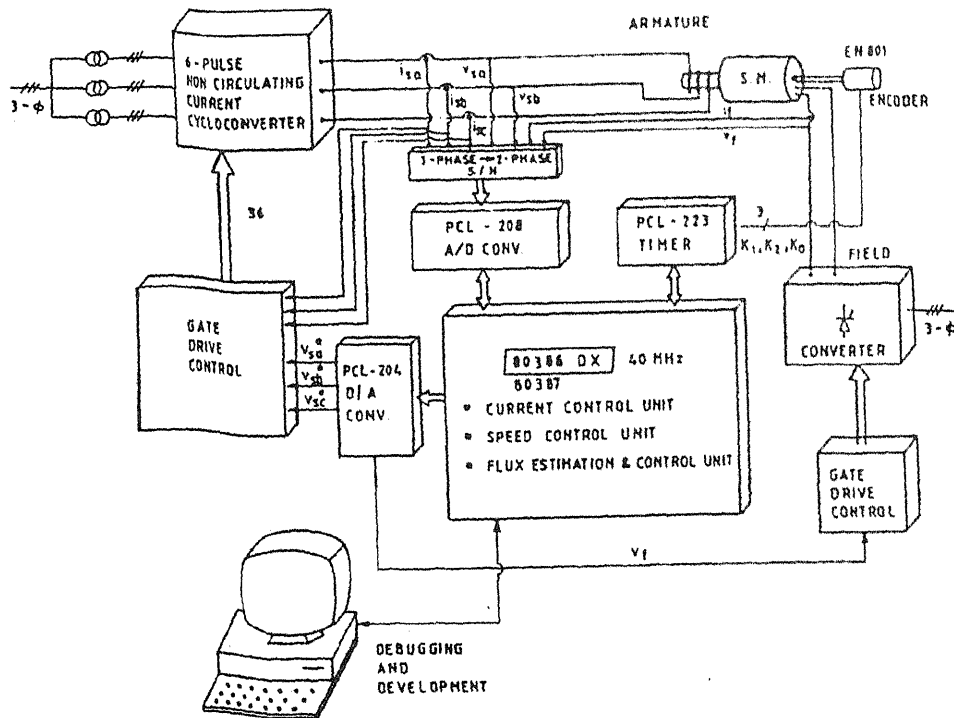

Fig. 13. Hybrid implementation of a cycloconverter-fed synchronous motor with a 386 PCAT<sup>74</sup>.

incorporated 'slip-limit' device<sup>30</sup>, 'flux controller'<sup>65</sup> and controlled slip-frequency drive for diesel electric locomotive<sup>66</sup> were developed in 1960's. Slip power controller drives with slipping induction motors either in the form of a cycloconverter type thyristor commutator<sup>31</sup> in the rotor to inject a slip-frequency emf as in the case of a stator-fed commutator motor (Fig. 14) or with a normal cycloconverter<sup>21-22</sup> were also developed. Another interesting application of cycloconverter was in realising the dc series motor characteristics with stator and rotor windings connected in series<sup>69</sup> where the torque angle was controlled by a shaft coupled transducer which manipulates the firing of the thyristors (Fig. 15) to provide a stabilised operation.

The development of vector-control or field orientation control in Germany<sup>77</sup> and its implementation<sup>67</sup> with microprocessors for both induction and synchronous motor control boosted up their applications for large capacity (> 1 MW) cycloconverter drives. This method of control permits optimum transient response of the drive. Though synchronous motors have been preferred in these schemes as described in the next section, with the improvements of their ratings and development of large capacity reactive power compensated cycloconverter<sup>93</sup> and absence of excitation control loop, the induction motor having a simple and robust structure, easy maintainability and quick response is now being favoured for cycloconverter applications in rolling mill drives, particularly in Japan<sup>17,71</sup>. A microcomputer-based cycloconverter-fed induction motor drive for seamless tube piercing mill is described in<sup>17</sup> where a squirrel cage 6 pole, 3 MW, 188/300 rpm, 9.6/15.38 Hz, 2700 V motor with overload capacity of 200% for 60 secs is controlled by a cycloconverter bank of capacity 3750 KVA and output voltage 3190 volts. The

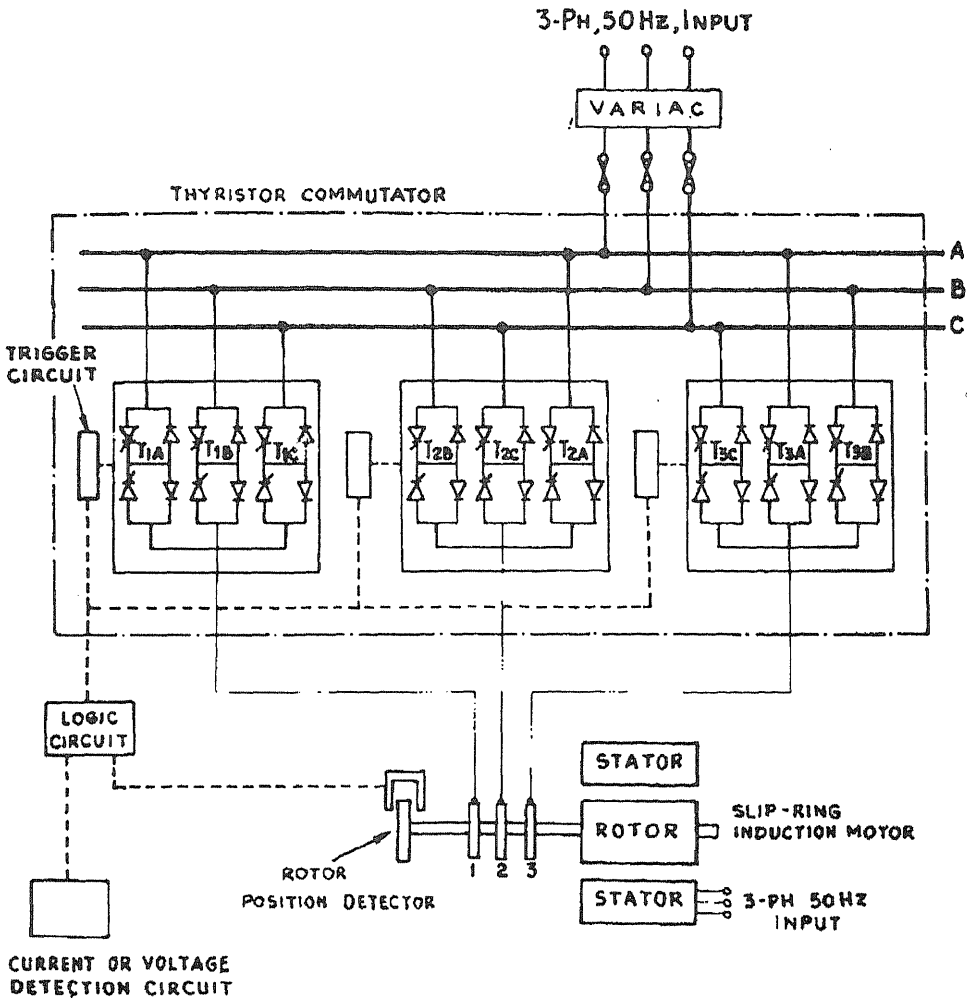

FIG. 14. Cycloconverter-type thyristor commutator motor<sup>20</sup>.

control scheme as developed by Toshiba with Sumitomo Industries of Japan consists of three 16-bit microprocessors and six single chip microcomputers for executing various control functions and firing of 72 thyristors. A high performance cross-current type cycloconverter configuration, controlled by two 16-bit microprocessors was suggested in<sup>62</sup> where the output voltage waveform is built up by simultaneously using positive and negative converters and allowing the mean voltage of the two converters to appear across the load. The advantages claimed are increase of output frequency limit and high input pf.

#### 4. Cycloconverter-controlled synchronous motor drives

The first ever experimental semiconductor cycloconverter variable drive began with a synchronous motor drive<sup>91</sup>. The cycloconverter-fed synchronous motor proved itself successful in

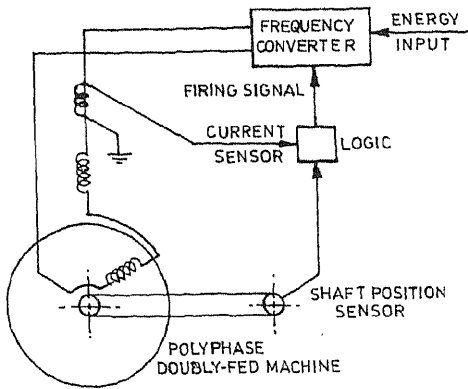

FIG. 15. Cycloconverter control of a doubly-fed induction motor<sup>60</sup>.

practice in the cement industry for large gearless Tube or Ball mills (8 MW) since early 1970's as developed by Siemens and Brown Boveri. One of the early installations (1969) employs a motor rating of 8700 hp, having a rotor drum 5 m in diameter and 16.5 m long while the stator

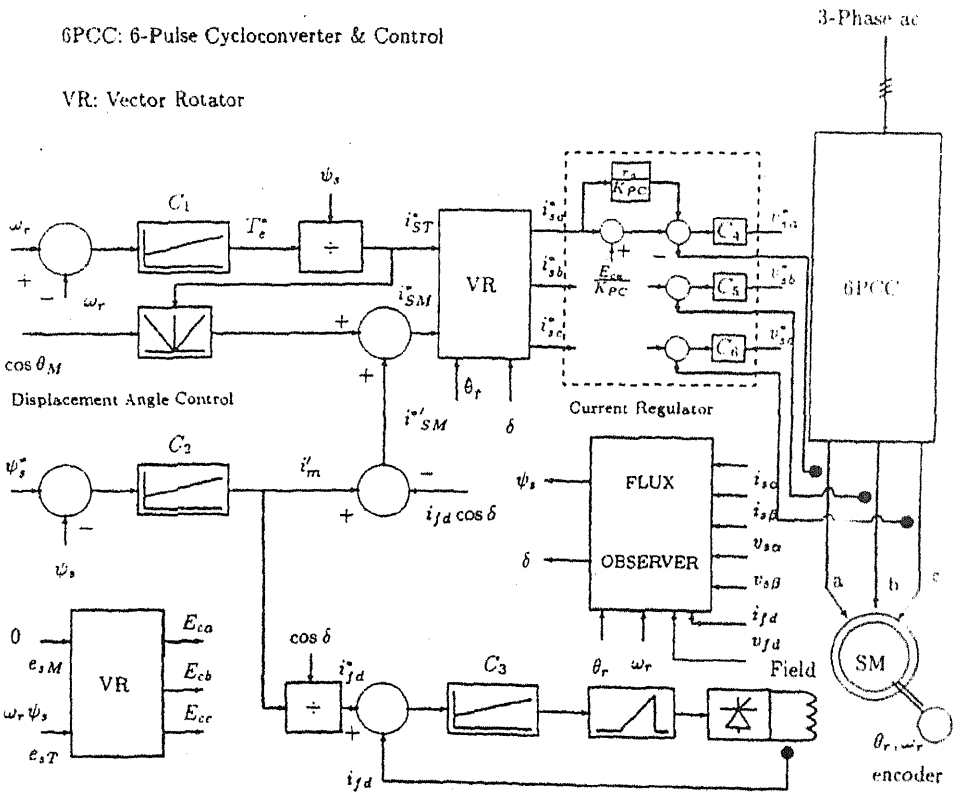

FIG. 16. Block diagram of the stator flux oriented vector control scheme with flux observer for a cycloconverter-fed synchronous motor<sup>61</sup>.

construction was similar to that of a hydroelectric generator with 44 poles requiring 5.5 Hz for maximum speed of 15 rpm. The motor is flanged into the mill cylinder without any additional bearings or 'wrapped' directly round it - known as 'ring motor'<sup>10</sup>. With 'self control mode' or as 'commutatorless ac motor'<sup>95</sup>, hunting and stability problems are eliminated and the torque is not limited to pull out value.

With field control, the operation can be at unity power factor. With 'field orientation' or vector control<sup>18,25,92,94</sup> (Fig. 16), the transient magnetizing current demand to maintain the rated flux can temporarily be supplied from the stator side to improve the response time instead of the field current control which is sluggish because of large time constant. A stator flux oriented vector control scheme for a 6-pulse non-circulating current cycloconverter-fed synchronous motor with a flux observer as developed recently at I.I.T. Kharagpur for a rolling mill drive is reported in Reference<sup>94</sup>. Fig. 16 shows the implementation scheme which aims at a stator flux oriented vector control that maintains a spatial orthogonality between the flux vector  $\psi_s$  and the armature current vector  $i_a$  as shown in the space phasor diagram of Fig. 17. The reference speed and the reference flux commands are given to the vector controller that generates the reference analog voltages for the cycloconverter and the field converter. The stator flux is estimated by a closed loop robust reduced order flux observer. Referring to Fig. 16,  $C_1$  is the speed controller that generates the torque command which is divided by the stator flux to generate the torque component of current  $i_{ST}$ . The magnetising current along the flux axis ( $i'_m$ ) is obtained from a flux controller  $C_2$ . The transient stator flux component of current  $i_{SM}^*$  is obtained from the relationship,  $i_{SM}^* = i'_m - I_{fd} \cos \delta$  which decays down to zero in the steady state. The steady state displacement angle is decided by the displacement angle controller. The set value of the field current is obtained from the relation  $i_{fd}^* = i'_m / \cos \delta$ .  $C_3$  is the field current controller that generates the control voltage for triggering the field converter. The vector rotator (VR) transforms the vectors from the two-axes flux-torque reference frame to abc stationary reference frame. The observer and the controller design aspects together with a PC-based implementation are detailed in Reference<sup>94</sup>.

The application of cycloconverter-fed synchronous motor drive with vector control have been extended to rolling Mills<sup>16</sup> (2/4 MW), mine-winders and haulage<sup>24</sup> and traction<sup>15</sup> which were dominated by dc drives due to requirements of speed accuracy and dynamic speed control. Methods of compensating armature reaction and control delay of current control circuit were suggested in Reference<sup>75</sup>.

Two different modes of operation were used to control the cycloconverter over the entire speed or frequency range for a cycloconverter-fed synchronous motor drive<sup>18</sup>: sinusoidal and trapezoidal. The trapezoidal mode is employed to improve the mains power factor in the upper speed range where the cycloconverter also has to supply higher voltages. Closed loop control methods with static and dynamic flux models were also described in Reference<sup>70</sup>.

Synchronous machines have been preferred as they can be built for higher capacity at low speed and their speed can be maintained constant for a particular frequency regardless of load or line voltage variation and the line power factor can be improved through excitation control with possible dual method of commutation<sup>14</sup>.

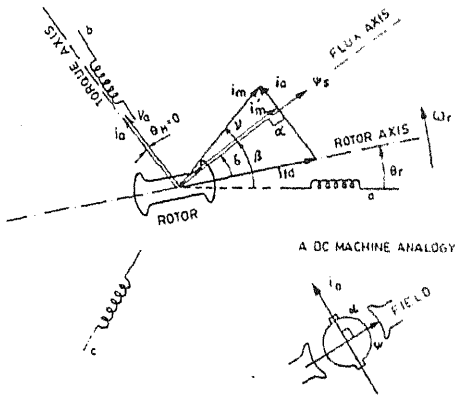

Fig. 17. Space phasor diagram of a vector controlled synchronous motor<sup>74</sup>.

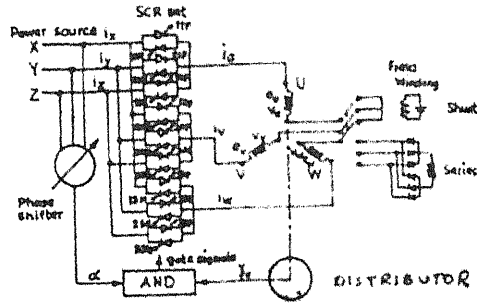

Fig. 18. Cycloconverter fed commutatorless motor.

An extremely flexible drive arrangement of a cycloconverter-type commutatorless motor with no theoretical speed limit was reported in<sup>72</sup>, Fig. 18, where both line and load commutation are employed and thyristors are triggered by a shaft position sensor. Depending on how the machine-field is connected, the machine characteristics can be 'series' or 'shunt' type.

**5. Modelling and simulation analysis of cycloconverters drives**

The non-linearity and discrete time nature of the cycloconverter-machine system makes an exact analysis quite complex. An ac equivalent circuit (Fig. 19) was developed earlier<sup>75</sup> with simplifying assumptions for a cycloconverter and was proposed for use with motor equivalent circuit to determine the performance of the cycloconverter-fed drives. However, a valuable design tool is the simulation of the drive system in an analog/digital/hybrid computer by which the effects of parameter variation can be readily examined and different open loop and closed loop designs may be tested by studying the dynamic performance without costly and time-consuming experiments with hardware.

Digital and hybrid computer simulation of induction motor drive fed from group - triggered mode cycloconverter which provides a trapezoidal waveform have been studied earlier<sup>81,82</sup>. A comprehensive two-axes digital model of a 3-pulse phase controlled cycloconverter-induction motor system suitable for dynamic and steady state analysis of the systems was presented<sup>83,84</sup>.

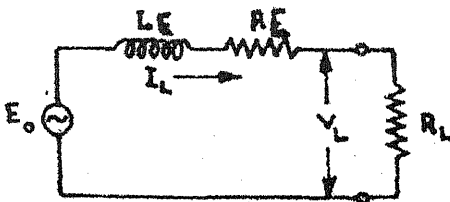

FIG. 19. Cycloconverter equivalent circuit<sup>79</sup>,  $R_E = (p/2\pi)\omega_s L$ ;  $L_E = L$ ;  $E_o = KE_{db} \sin \omega_s t$ .

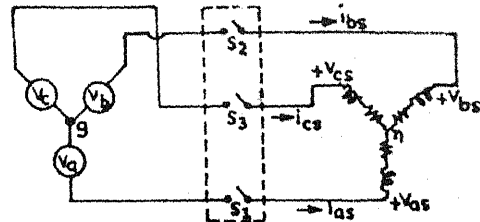

FIG. 20. Representation of induction motor with switchings in the stator<sup>83</sup>.

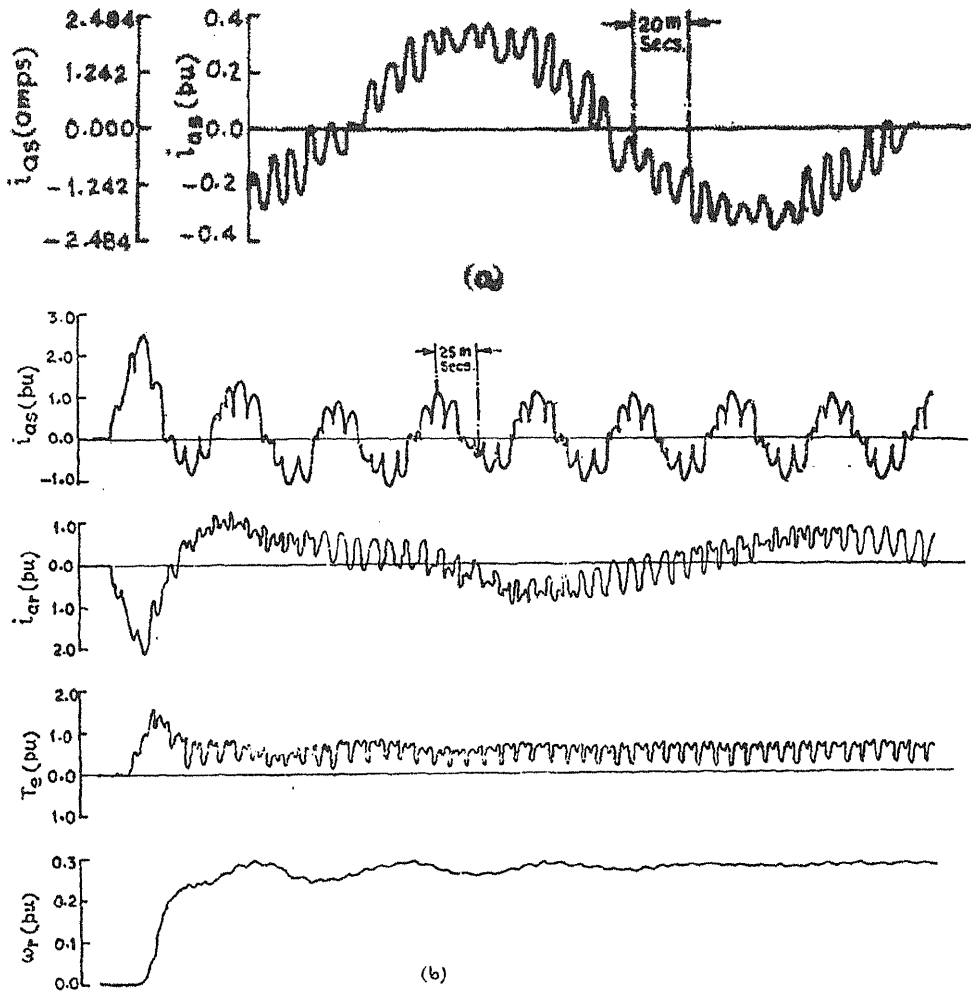

FIG. 21a. Digitally computed steady-state current waveform for 5 Hz. b. Dynamic performance of induction motor with 3-pulse cycloconverter. Digital simulation results.  $f_s = 16$  Hz,  $k_r = 0.806$ ,  $V_r = 0.5$  pu,  $T_L = 0.5$  pu (Non-circulating current mode)<sup>82</sup>.

for both continuous and discontinuous current operation under circulating as well as non-circulating current operation. The induction motor model used follows the approach suitable for any reference frame<sup>84</sup>. A generalized mathematical model has been derived in Reference<sup>83</sup> for this purpose using switching variables to represent thyristors' conducting states (Fig. 20) and combining five sets of equations in five relevant modes of operation involving only a  $4 \times 4$  matrix without need of any matrix inversion. The cycloconverter model for digital computation of output waveforms is discussed in Reference<sup>85</sup>. One of the methods which is very fast and convenient is the 'cross-over points' method - which gives the cross-over points (intersections of modulating and reference waves) and the conducting phase numbers for both P- and N groups

from which the output waveforms for a particular load current may be digitally computed at any interval of time as in a practical cycloconverter. Typical computer results presented in Fig. 21, show the dynamic and steady state performance of the system as computed. An experimental oscillogram recorded for the same condition has been shown in Fig. 11 earlier. An attempt to obtain directly (without iteration) the steady state performance of the same drive by using state variable technique has also been reported<sup>86</sup>. Both analog and digital computer simulations of an induction motor drive with cycloconverter-type thyristor-commutator in the rotor have been presented earlier<sup>87,88</sup>. Analysis of dynamics of a cycloconverter-fed squirrel cage motor for mine winders by computer simulation was reported quite early<sup>89</sup>. A simulation study of an optimal numerical control of a cycloconverter is reported in Reference<sup>90</sup>.

A simulation method for cycloconverter-fed 3-phase and 6-phase synchronous motors based on equivalent voltage sources during discontinuous stator current was presented in Reference<sup>91</sup>. Digital simulations as developed for a vector-controlled six-pulse cycloconverter-fed synchronous motor drive with flux observer are detailed in<sup>94,100</sup>, and for a a.c. commutator motor with

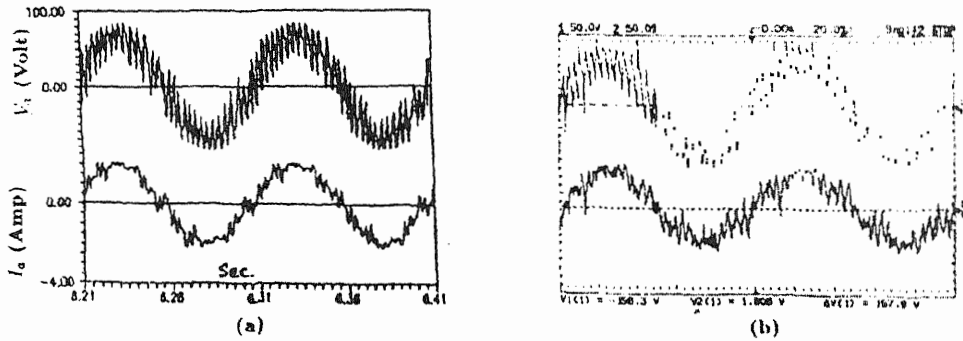

FIG. 22a. Sinusoidal mode of operation (a) Simulated (b) Experimental<sup>95</sup> 6-pulse cycloconverter-fed synchronous motor drive, 300 rpm, U.P.F.

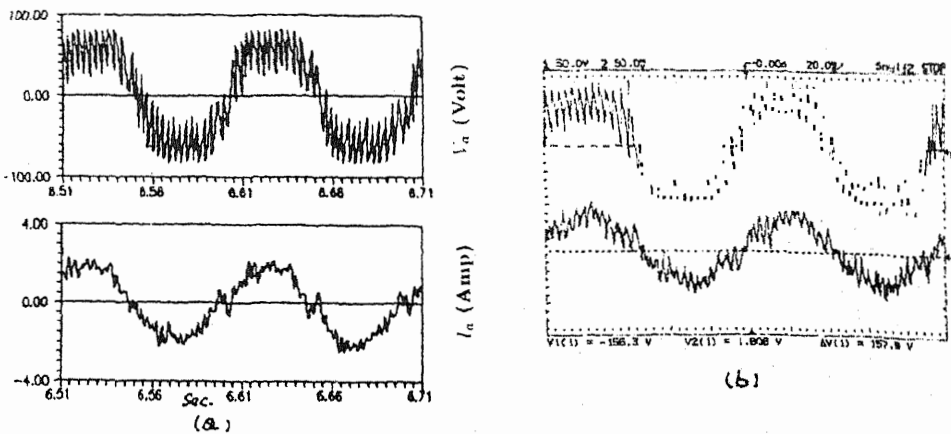

FIG. 22b. Trapezoidal mode of operation (a) Simulated (b) Experimental<sup>95</sup>.



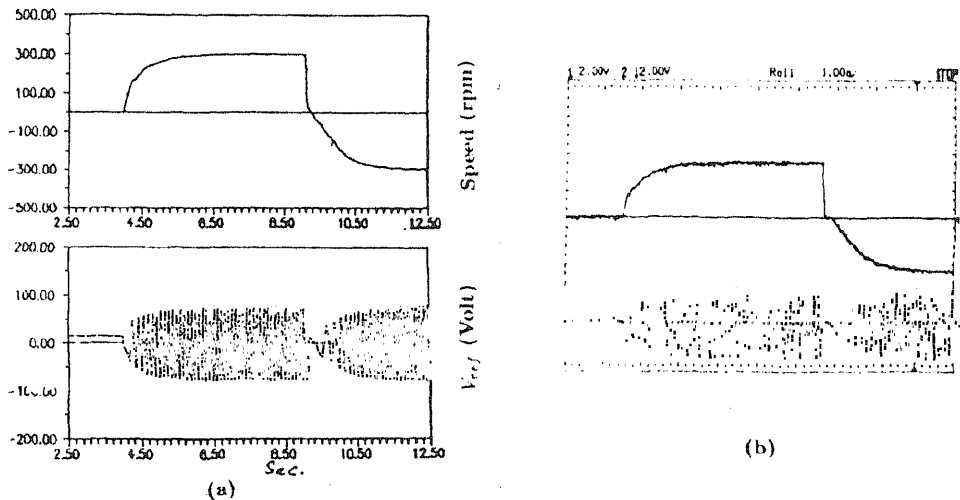

FIG. 22c. Response of the drive to step speed changes (a) Simulated (b) Experimental<sup>95</sup> +300 to -300 rpm.

out vector control<sup>95</sup>. Fig.22 shows typical simulated and experimental results (for sinusoidal and trapezoidal mode of operation). The factors to be considered for selecting either a synchronous motor or an induction motor for cycloconverter use have been discussed in a recent paper<sup>99</sup>.

## 6. Conclusions

A comprehensive but brief survey of cycloconverters and their applications to the control of ac drives has been presented here to provide background information regarding the present research and development trends in the area. Systems employing cycloconverter are gaining ground steadily with inclusion of microcomputers and literature on them have proliferated. Only some salient features and significant developments have been highlighted here and for proper design and evaluation for a particular application, one has to study in depth many trade-off considerations and relevant texts given in the references.

## References

1. HAZELTINE, L. A.,  
An improved method of and apparatus for converting electric power, British Patent No. 218. 695, 1926.
2. RISSIK, H.,  
*Mercury Arc Converters*, Sir Issac Pitman & Sons, 1935.
3. ALEXANDERSON, E. AND MITTAG, A.,  
The Thyatron Motor, *Elec. Engg. (AIEE)*, 1934, **53**, pp 1517-1523.
4. RICH, E. A. E.,  
Concepts of gearless Ball-Mill drives, *IEEE Trans.*, 1969, Vol. IGA-5, pp 13-17.
5. BLAUENSTEIN, E.,  
The first gearless drive for a Tube Mill, *Brown Boveri Review*, 1970, **57**, pp 96-105.

6. LANGER, J., Static Frequency changer supply system for synchronous motor driving tube mills, *Brown Boveri Review*, 1970, **57**, pp 112-119.
7. Stemmler, H., Drive system and electric control equipment of the gearless tube mill, *Brown Boveri Review*, 1970, **57**, pp 120-128.
8. WURGLER, H. V., The World's First Gearless Mill Drive, *IEEE Trans. IGA-6*, 1970, pp 524-527.
9. Richlein, D., Gearless Drive for a Cement Mill, *Siemens Review*, 1971, **38**, pp 398-401.
10. ALLEN, J. A., WYETH, W. A., HERZOG, G. W. AND YOUNG, J. A. I., Electrical aspects of the 8950 hp Gearless Ball Mill Drive at St. Lawrence Cement Company, *IEEE, IA-11*, 1975, pp 681-687.
11. Salzmann, T., Cycloconverter and automatic control of Ring Motors driving tube mill, *Siemens Review*, XLV, 1978, pp 3-8.
12. MUSIL, R., State of development of Gearless drives of Ball Mill, *Siemens Review*, Vol.XLIII, **3**, 1976, pp. 542-546.
13. Weiss, H. W., Adjustable-speed ac drive systems for pump and compressor applications, *IEEE Trans. IA*, Vol. IA-10, 1, 1975, pp 162-167.
14. JACOVIDES, L. J., MATOUKA, M. F., Shimer, D. W., A cycloconverter synchronous drive for traction applications, *IEEE Trans. IA* Vol. IA-12, 4, July/Aug 1981 pp 407-418.
15. SAJJO, T., *et al.*, Characteristics of linear synchronous motor drive cycloconverter for Maglev Vehicle ML-500 at Miyazaki Test Track', *IEEE Trans. IA-17*, 1981, pp. 533-543.
16. TIMPE, W., Cycloconverter drives for rolling mills, *IEEE Trans. IA-18*, 1982, **41**, pp. 401-404.
17. SUGI, K., *et al.*, A microcomputer-based high capacity cycloconverter drive for main rolling mill, *Proc. IPEC*, Tokyo, 1983, pp 744-755.
18. NAKANO, T., OHSAWA, H. AND Endoh, K., A high performance cycloconverter-fed synchronous machine drive system', *IEEE Trans. IA-20*, 1984, **5**, pp. 1278-1284.
19. CHIRGWIN, K. M. AND STRATON, L. J., Variable-speed constant frequency generator system for aircraft, *AIEE Trans.* Vol. 78, pt II, 1959, pp. 304-310.
20. CHATTOPADHYAY, A. K., An adjustable-speed induction motor drive with a cycloconverter-type thyristor commutator in the rotor, *IEEE Trans. IA-14*, 1978, **2**, pp. 116-122.
21. SMITH, G. A., Static Scherbius System of induction motor control, *Proc. IEE*, Vol. 124, 1973, pp. 557-560.
22. DIRR, R., *et al.*, New Electronic control equipment for Doubly -fed induction motors of high rating, *Siemens Rev.* 3, 1972, pp. 121-126.
23. GIBBS, F. S., Power Engineering for tomorrow's industry-plant, *Electronics and Power*, 1982, pp. 41-45.
24. MADISETTI, V. K. AND RAMLU, M. A., Trends in the Electronic Control of Mine Hoists, *IEEE Trans. IA-22*, 1986, **6**, pp. 1105-1112.
25. HILL, W. A., *et al.*, A vector-controlled cycloconverter drive for an ice-breaker, *IEEE Trans. IA-23*, 1987, **6**, pp. 1036-1041.

26. BIRD, B. M. AND FORD, J. S. Improvement in phase-controlled circulating current cycloconverter using communication principles, *Proc. IEE*, Vol. 121, 1974, **10**, pp. 1146–1149.
27. SMITH, G. P. AND RAMSDEN, V. S., A study of new technologies for the control of cycloconverters with reference to ac machine control, *Proc. Inst. of Engineers (Australia)*, EE-14, 1978, **2**, pp. 92–96.
28. TAMURA, Y. *et al.*, Control method and upper limit frequency in circulating - current type cycloconverter, *IEEE - IAS Ann. Meeting Conf. Rec.*, 1982, pp. 313–323.
29. SHIMER, P. W. AND JACOVIDES, L. J. An improved triggering method for a high power cycloconverter-induction motor drive, *IEEE-IA-15*, 1979, **5**, pp. 472–481.
30. BOWLER, P., The application of cycloconverter to the control of induction motors, *IEE Conf. Pub.*, 1965, **17**, pp. 137–145.
31. PELLY, B. R., *Thyristor phase-controlled converters and Cycloconverters*, Wiley Interscience, 1971.
32. McMurray, W., *The Theory and design of cycloconverters*, The MIT Press, Cambridge, 1972.
33. GYUGI, L. AND PELLY, B. R., *Static Power Frequency Changers*, John Wiley & Sons Inc. New York, 1976.
34. BLAND, R. J., Factors affecting the operation of a phase-controlled cycloconverter, *Proc. IEE*, Vol. 114, 1967, **12**, pp. 1908–1916.
35. LAWSON, L. J., The Practical Cycloconverter, *IEEE Trans.* Vol. IGA-4, 1968, pp. 141–144.
36. TAKAHASI, I. AND MIYARI, S., Triggering schemes and waveform analysis of cycloconverter, *Elec. Engg. in Japan*, Vol. 90, 1970, **2**, pp. 95–104.
37. HAMBLIN, T. M. AND BARTON, T. H., Cycloconverter control circuits, *IEEE Trans. IA-8*, 1972, pp. 443–453.
38. CHATTOPADHYAY, A. K. AND RAO, T. J. Simplified control electronics for a practical cycloconverter, *Int. J. Electronics*, Vol. 43, 1977, **2**, pp. 137–150.
39. SCHONUNG, A. AND STEMMLER, H., Static frequency changer with subharmonic control in conjunction with reversible speed ac drives, *Brown Boveri Review*, Vol. 51, 1964, pp. 555–599.
40. REVANKAR, G. N. AND NALLATHAMBI, K., Three phase half wave cycloconverter, *JITE(I)*, Vol. 18, 1972 **2**, pp. 79–84.
41. WALDEN, J. P. AND TURNBULL, F. G., Adjustable voltage and frequency polyphase sine wave signal generator, *IEEE IAS Conf. Rec.*, 1974, pp. 1015–1019.
42. PARASURAM, M. K. AND RAMASWAMI, B., A three phase sine wave reference generator for thyristorized motor controllers, *IEEE Trans. IECEI-23*, 1976, **3**, pp. 270–276.
43. RAHAMAN, A. AND Haque, S. E., A simple three-phase variable frequency oscillator, *Int. J. Electronics*, 1982, Vol. 53, **1**, pp 83–89.
44. CLARKE, D. J. AND SEN, P. C., A versatile three phase oscillator, *IEEE Trans. IECEI-24*, 1977, **1**, pp. 57–60.

45. MATOUKA, M. F. Read only Memory (ROM) trigger generator for phase controlled cycloconverter, *IEEE Trans. IECI-25*, 1978, 2, pp. 155-164. 6
46. BROWN, G. M. AND Szebades, B. A flexible hybrid firing controller for cycloconverter drives, *IEEE Trans. IE-33*, 1986, 3, pp. 297-303. 6
47. TADAKUMA, S. AND TAMURA, Y., Current response simulation in six phase and twelve-phase cycloconverters, *IEEE Trans. IA-15*, 1979, 4, pp. 411-420. 6
48. ISSAWI, A. M. *et al.*, A novel twelve pulse cycloconverter for the speed control of induction motors, *IEE Conf.on Power Elect. and Variable Speed drives*, London, 1984, pp. 257-260. 6
49. CHEN, H. H., A microprocessor control of a three pulse cycloconverter, *IEEE Trans. IECI-24*, 1977, 4, pp. 226-230. 6
50. SINGH, D. AND HOFT, G. R., Microprocessor-controlled single phase cycloconverter, *IEEE Trans. IECI-25*, 1978, 3, pp. 233-246. 6
51. TSO, S. K. AND SPOONER, E. D., Efficient Microprocessor based cyclonconverter control, *Proc. IEE.*, Vol. 127, 1980, B3, pp. 190-196. 6
52. TSO, S. K. AND LAUNG, C. C., Microprocessor control of triac cycloconverter, *Proc. IEE*, Vol. 130, 1983, B3, pp. 193-200. 7
53. BETZ, R. E. AND EVANS, R. J., Microprocessor control of a cycloconverter, *IEEE Trans.*, Vol. IECI-32, 1985, 2, pp. 120-130. 7
54. ICHIDA, H., *et al.*, Microprocessor-based digital control (DCC) cycloconverter application to induction motor speed control, *IEEE Trans. IECI-32*, 1985, 4, pp. 414-421. 7
55. SHARDE, N. K., *et al.*, Microprocessor control of cycloconverter Techniques for implementation and testing, *IEEE Trans. IE-33*, 1986, pp. 281-291. 7
56. MIWAZARA, S., *et al.*, A new method for developing the control scheme of a CVVF cycloconverter, *IEEE Trans. IE-33*, 1982, pp. 304-309. 7
57. TSO, S. K. AND Tang, K. H., Digital control stratagies for sinewave - output cycloconverters, *IEEE Trans. IE-37*, 1990, pp. 70-76. 7
58. ARSOV, G., A novel algorithm for microcomputer based digitally controlled cycloconverter, *IEEE Trans. IE-38*, 1991, pp. 404-405. 7
59. MIYAZAWA, S., *et al.*, Effective approximations suitable for the control algorithm of microprocessor-based control of a single-phase output cycloconverter, *IEEE Trans. IE-30*, 1989, pp. 560-567. 7
60. MIYAZAWA, S., *et al.*, A novel strategy for microcomputer based control of a single-phase output cycloconverter, *IEEE Trans. IE-36*, 1989, pp. 560-567. 7
61. VEDA, R., *et al.*, Stabilization of bank selection in no-circulating cycloconverter by means of reliable current zero and current polarity detection, *IEEE Trans. IA-20*, 1984, pp. 827-833. 7
62. Hosada, H., *et al.*, A high performance cross current type cycloconverter-fed induction motor drive system, *IEEE Trans. IA-24*, 1988, pp. 479-486. 8
63. HAMILTON, R. A. AND LEZAN, G. R., Thyristor adjustable frequency power supplies for hot strip mill run-out table, *IEEE trans. IGA-3*, 1967, pp. 168-175. 8

64. SLABIAK, W. AND LAWSON, L. J., Precise control of a three phase squirrel cage induction motor using a practical cycloconverter, *IEEE Trans. IGA-2*, 1966, pp. 274-280.
65. HCCK, R. AND MEYER, M., A static frequency changer-fed squirrel cage motor drive for variable-speed and reversing, *Siemens Review*, 1963, pp. 401-405.
66. PINTER, G. E., The cycloconverter adjustable-speed drives, *Machine Design*, 1966, pp. 150-157.
67. HASSE, K., Control of cycloconverters for feeding of asynchronous machines, *Proc. IFAC Control of Power Electronics and Elect. Drives*, 1977, pp. 537-546.
68. MAYER, C. B., High response control of stator watts and vars for large wound rotor induction motor adjustable speed drives, *IEEE-IAS 1979 Ann. Meet. Rec.*, 1979, pp. 817-823.
69. LONG, W. F. AND Schmitz, N. D., Cycloconverter control of the doubly-fed induction motor, *IEEE Trans. IGA-6*, 1990, pp. 349-356.
70. HUNTER, G. P. AND Ramsden, V. S., New improved modulation method for a cycloconverter driving an induction motor, *Proc. IEE*, Vol. 135, pt B, 1988, pp. 324-333.
71. KURUSOWA, R., *et al.*, A microcomputer based high power cycloconverter-fed induction motor drive, *IEEE-IAS Ann. Meet. Rec.*, 1982, pp. 462-467.
72. TSUCHIYA, T., Basic characteristics of cycloconverter type commutator less motors, *IEEE Trans. IGA-6*, 1970, pp. 349-356.
73. MAENO, T. AND KOBATA, M., AC commutatorless and brushless motors, *IEEE Trans. PAS-91*, 1972, pp. 1476-1484.
74. FINLAYSON, P. T. AND WASHBURN, D. C., Cycloconverter-controlled synchronous machines for load compensation on ac power systems, *IEEE Trans. IA-10*, 1974, pp. 806-813.
75. OKUYOUMA, T., *et al.*, Cycloconverter-fed synchronous motor drive for steel rolling mill, *IEEE-IAS Ann. Meet.*, 1978, pp. 820-827.
76. TERENS, L., *et al.*, The cycloconverter-fed synchronous motor, *Brown Boveri Review* 4/5, 1982, pp. 122-132.
77. BLASCHKE, F., The principle of field orientation as applied to the new transvector closed loop control system for rotating machine, *Siemens Review*, Vol. 39, 5, 1972, pp. 217-220.
78. BAYER, K. H., *et al.*, Field orientated close-loop control of a synchronous machine with the new Transvector control system, *Siemens Review*, Vol. 39, 1972, pp. 220-223.
79. AMATO, C. J., An ac equivalent circuit for a cycloconverter, *IEEE Trans. IGA-2*, 5, 1966, pp. 358-362.
80. RAJAN, S. D., *et al.*, Digital simulation of a high performance ac drive system, *IEEE Trans. IA-10*, 3, 1974, pp. 391-396.
81. Krause, P. C., *et al.*, Application of analog and hybrid computers in Electrical Power system, *Proc. IEEE*, Vol. 62, 1974, pp. 994-1009.

82. CHATTOPADHYAY, A. K. AND RAO, T. J., Digital simulation of a phase - controlled cycloconverter induction motor drive system, *IEEE-IAS Ann. Meeting Rec.*, 1978, pp. 853-860.
83. CHATTOPADHYAY, A. K. AND RAO, T. J., A generalised method of computer simulation of induction motors with stator current discontinuities and its application to a cycloconverter-fed drive, *IEEE Trans. Vol. IA-16*, 1980, pp. 234-241.
84. KRAUSE, P. C. AND THOMAS, C. H., Simulation of symmetrical induction machinery, *IEEE Trans. PAS-84*, 1965, pp. 1038-1053.
85. CHATTOPADHYAY, A. K. AND RAO, T. J., Methods of digital computation of phase-controlled cycloconverter performance, *IEEE-IAS Ann. Meet Rec.*, 1978, pp. 432-439.
86. CHATTOPADHYAY, A. K. AND RAO, T. J., State variable steady state analysis of a phase-controlled cycloconverter induction motor drive, *IEEE Trans. IA-15*, 1979, pp. 313-319.
87. CHATTOPADHYAY, A. K., Analog computer simulation of an adjustable speed induction motor drive with cycloconverter type thyristor commutator in the rotor, *IEEE Trans. IECE-22*, 1975, pp. 433-440.
88. CHATTOPADHYAY, A. K., Digital computer simulation of an adjustable speed induction motor drive with cycloconverter type thyristor commutator in the rotor, *IEEE Trans. IECE-23*, 1976, pp. 89-92.
89. SZKLARSKI, L. M. AND DZIADZECKI, A., The analysis of dynamics of induction motor drives of mine-winders with frequency control, *Proc. IFAC- Sympo. on Control of Power Elec. and Drives*, 1977, pp. 699-709.
90. MAHMOUD, S. AND LEDOEUFF, R., A simulation study of an optimal numerical control of a three-phase cycloconverter, *Electric Machines and Power Systems*, 1984, pp. 325-334.
91. GRIFFITH, D. C. AND ULMER, R. M., A semi-conductor variable speed ac motor drive, *Elect. Engg.*, 1961, pp. 350-353.
92. BOSE, B. K., *Power Electronics & AC Drives*, Prentice Hall, New Jersey, 1986.
93. FUJIWARA, M., *et al.*, Development of large capacity reactive power compensated cycloconverter, *Proc. IPEC*, Tokyo, 1983, pp. 1420-1430.
94. DAS, S. P. AND CHATTOPADHYAY, A. K., Observer based state flux oriented vector control of cycloconverter-fed synchronous motor drive, *Proc. PEDES'96*, New Delhi, 1996, pp. 236-242. *IEEE Trans. on Ind. Appl.*, (IA-33, 1997, 4, pp. 943-955)
95. DAS, S. P. AND CHATTOPADHYAY, A. K., Comparison of simulation and test results for an ac commutatorless motor drive, *Proc. PEVD'96 (IEE)*, 1996, pp. 294-299.
96. DAS, S. P. AND CHATTOPADHYAY, A. K., Modelling of a cycloconverter fed synchronous motor drive under field co-ordinate control, *Conf. Proc. INTRONICS'94*, Bangalore, 1994, pp. 17-113.
97. DAS, S. P. AND CHATTOPADHYAY, A. K., Design and simulation of a robust reduced order observer for a synchronous motor drive, *Conf. Proc. NSC'94*, Dayalbagh (Agra), 1995, pp. 619-622.

98. NIIRANEN, J.,  
Simulation of cycloconverter-fed three- and six-phase synchronous motors during discontinuous stator current, *Proc. Int. Conf. on Evolution and Modern aspects of Syn. Machines*, Zurich, 1991, pp. 367–372.
99. LEWIS, E. A.,  
Cycloconverter drive systems, *IEE Conf. Proc. PEVD'96*, 1996, pp. 382–389.
100. DAS, S. P.,  
*Design, simulation and PC-based implementation of a high performance cycloconverter-fed synchronous motor drive system.* PhD Thesis, submitted to Elec. Engg. Dept., IIT Kharagpur, September. 1996.