

27  
4/16/79  
2-48  
VTL5

SAND78-1972  
Unlimited Release

# Data Acquisition and Test System Software

Nick A. Bourgeois, Jr.



Sandia Laboratories

SF 2900 Q(7-73)

**MASTER**

DISTRIBUTION OF THIS DOCUMENT IS UNLIMITED

SAND78-1972  
Unlimited Release  
Printed March 1979

DATA ACQUISITION AND TEST SYSTEM SOFTWARE

Nick A. Bourgeois, Jr.  
Advanced Systems Development Division 1736  
Sandia Laboratories  
Albuquerque, NM 87185

ABSTRACT

A number of programs have been written for the Data Acquisition and Test System (DATS). These include both real time signal processing algorithms as well as data acquisition programs.

NOTICE  
This report was prepared as an account of work sponsored by the United States Government. Neither the United States nor the United States Department of Energy, nor any of their employees nor any of their contractors, subcontractors, or their employees, make any warranty, express or implied, or assumes any legal liability or responsibility for the accuracy, completeness or usefulness of any information, apparatus, product or process disclosed, or represents that its use would not infringe privately owned rights.

This document is issued by Sandia Laboratories, operated for the United States Department of Energy by Sandis Corporation.

NOTICE

This document was sponsored by the United States government. Neither the United States government nor the United States Department of Energy, nor any of their employees, nor any of their contractors, subcontractors, or their employees makes any warranty, express or implied, or assumes any legal liability or responsibility for the accuracy, completeness or usefulness of any information, apparatus, product or process disclosed, or represents that its use would not infringe privately owned rights.

This work was sponsored and funded by:  
Base and Installation Security Systems Program Office  
Electronic Systems Division  
Air Force Systems Command  
Hanscom Air Force Base, MA 01731

\*\*\*\*\*  
\*                   \*  
\* UNCLASSIFIED \*  
\*                   \*  
\*\*\*\*\*

## DATA ACQUISITION AND TEST SYSTEM SOFTWARE

### INTRODUCTION

Sandia Laboratories has been assigned the task by the Base and Installation Security Systems (BISS) Program Office to develop various aspects of perimeter security systems. One part of this effort involves the development of advanced signal processing techniques to reduce the false and nuisance alarms from sensor systems while improving the probability of intrusion detection. Hence, the need existed for both data acquisition hardware and software. Also, the hardware is used to implement and test the signal processing algorithms<sup>1-6</sup> in real time.

The hardware developed for this signal processing task is the Data Acquisition and Test System (DATS).<sup>7</sup> Descriptions of the programs developed for use on DATS appear in the following pages. The descriptions are taken directly from the documentation included within the source programs themselves.

The RT-11 V02C floppy disk monitor and handler as obtained from Digital Equipment Corporation (DEC)<sup>\*</sup> has been modified to increase the maximum data rate.<sup>9</sup>

DXMNSJ/DX: 24-Sector Floppy Disk Operating System

The original data acquisition programs are written partly in FORTRAN and partly in assembly language.

---

\*DEC is a registered trademark of Digital Equipment Corporation, Maynard, MA 0174.

DATS1.FOR/ADAC1.MAC: Single Channel Sampler  
DATS2.FOR/ADAC2.MAC: Dual Channel Sampler

These two data recording programs are written entirely in assembly language. They may be triggered either manually or automatically. The dual channel transient recorder makes more efficient use of the data disk than the dual channel sampler.

TROSMP.MAC: Single Channel Transient Recorder  
TRISMP.MAC: Dual Channel Transient Recorder

The playback programs may be used to deliver previously recorded data to another processor. Also, the single channel program is useful for visual display of such data.

BSDOUT.MAC: Data Playback Program  
DBSDOT.MAC: Dual Channel Data Playback Program

The real time adaptive algorithms contain many bells and whistles which may be enabled at assembly time. Diagnostic code and file input/output are among these additional features incorporated as conditional assembly code.

WDWDAS.MAC: Real Time Widrow Adaptive Filter  
TRANSFR.MAC: Real Time Adaptive Transfer Filter  
AFMATD.MAC: Real Time Adaptive Filter, Moving  
Average Filter and Adaptive Threshold  
Detector

Dual channel input signal and internal status data of the Sensor Signal Processor Development Unit (SSPDU II)<sup>9</sup> are recorded in transient recorder mode either when SSPDU II detects an alarm or on manual command.

SPDUVL.MAC: Real time SSPDU II Monitor

DXMNSJ/DX  
24-Sector Floppy Disk Operating System<sup>8</sup>

A requirement existed to do real time data acquisition at a sample rate of 1024 Hz. The standard RT-11 floppy disk handler, DX.SYS, was unable to keep abreast of this data rate. It required about 7.5 seconds to transfer 2 seconds of data from memory to disk. The data transfer between the disk and memory occurs in two steps, a memory-controller transaction and a controller-disk transaction. When using the LSI-11<sup>10</sup> computer the memory-controller transaction takes about twice as much time as the controller-disk transaction. Therefore, only one memory-disk transfer can be achieved during a single rotation of the disk. The modifications described here allow up to six memory-disk transfers per disk revolution.

Certain components of the floppy disk software within the RT-11 operating system have been modified to permit a real time thru-put in excess of 1024 Hz. This was accomplished by changing the sector interleave, track skew and sectors per track parameters.

In standard RT-11 configuration a 2:1 sector interleave is used on a single track, a 6-sector skew is used across tracks and each track contains 26 sectors. The modifications change these parameters to 4:1 interleave, 8-sector skew and 24 sectors per track. This reduces the capacity of the disk by about 8 percent.

In order to implement the 24-sector floppy disk software, an RT-11 operating system must have an RK01 as an auxiliary device and a system device such as an RK05. A copy of the modified handler is installed on this host machine via PATCH. The modified handler is then used to build floppy disk copies which are bootable on an LSI-11 machine.

The following RT-11 modules have been modified and renamed as shown. All modifications require the definition of a conditional assembly switch.

DXSYS.MAC	D4SYS.MAC
BSTRAP.MAC	B4STRP.MAC
KMON.MAC	K4MON.MAC
RMONSJ.MAC	R4MNSJ.MAC
DX.MAC	D4.MAC

The D4SYS.MAC module contains the conditional switch definitions used by the MACRO assembler to select the code for the floppy disk and the 24-sector modifications contained in the other modules.

The B4STRP.MAC module is the software bootstrap program. The hardware boot reads the first part of the software boot from block 0 sector 1 of the disk. The software bootstrap program has been modified to continue reading itself into memory from absolute sectors 5, 9, and 13 (block 0, logical sectors 2, 3, and 4). Reading then continues using a subroutine which has been modified for 4:1 sector interleave, 8-sector skew and 24 sectors per track.

K4MON.MAC is the keyboard monitor. The 'HSIZE' MACRO call has been modified to reflect the change in the size of the floppy handler, D4.MAC.

R4MNSJ.MAC is the resident monitor module. The 'DEVICE' MACRO call has been modified to reflect the reduced size of the disk.

The D4.MAC module is the floppy disk handler. The read/write routine has been modified for 4:1 sector interleave, 8-sector skew and 24 sectors per track.

Details of these modifications are flagged in all source files. Batch streams are available to control the assembly and linking operations. Batch streams are also available to control the building of operating systems for BASIC, FORTRAN, and MACRO.

DATS1.FOR/ADAC1.MAC  
Single Channel Sampler

The program consists of the following modules:

DATS1.FOR: User level FORTRAN program to acquire a sample set with the ADAC-LSI-11<sup>11</sup> system.  
ADAC1.MAC: FORTRAN callable assembly language driver for the ADAC-SLI-11 system.

DATS1.FOR

This program will operate DATS<sup>7</sup> under 24-sector RT-11<sup>8</sup> to obtain single channel data at a maximum sample rate of 1024 Hz. After identifying itself the program states the maximum sample rate and the data record size. One data record consists of 2048 samples. It then asks the operator to enter the required number of data records, the name for the data file and the ADAC gain. The operator is then asked to command the start of sampling. The program so indicates, when sampling is done. A number of diagnostic messages are available for output should the need arise. An empty disk can hold a maximum of 55 data records. This corresponds to the following data window times:

Sample Rate	Data Window
Hz	MIN:SEC
1024	1:50
512	3:40
256	7:20
128	14:40

ADAC1.MAC

This routine starts the ADAC clocked sampling and interrupt driven data transfers. It also writes the data to the file in double buffered fashion while maintaining sampling activity. The calling sequence is as follows:



CALL ADACDR(NSMPLS, IDATA, IWORD, ICHAN)

Where	NSMPLS	number of records to be taken
	IDATA	name of the data array
	IWORD	data record size
	ICHAN	output channel number

DATS2.FOR/ADAC2.MAC  
Dual Channel Sampler

The program consists of the following modules:

DATS2.FOR: User level FORTRAN program to acquire two  
sample sets with the ADAC-LSI-11<sup>11</sup> system.  
ADAC2.MAC: FORTRAN callable assembly language driver  
for the ADAC-SLI-11 system.

DATS2.FOR

This program will operate DATS<sup>7</sup> under 24-sector RT-11<sup>8</sup> to obtain dual channel data at a maximum sample rate of 512 Hz. After identifying itself, the program states the maximum sample rate and the data record size. One data record consists of 2048 samples. It then asks the operator to enter the required number of data records per channel, the names for the data files and the ADAC gain. The operator is then asked to command the start of sampling. The data is first recorded and packed into a single temporary file. The program indicates when sampling is done. Then the data is unpacked and put into separate permanent files. A number of diagnostic messages are available for output should the need arise. An empty disk can hold a maximum of thirteen data records per channel. This corresponds to the following data window times:

Sample Rate	Data Window
Hz	MIN:SEC
512	0:52
256	1:44
128	3:28

ADAC2.MAC

This routine starts the ADAC clocked sampling and interrupt driven data transfers. It also writes the data to the temporary file in double buffered fashion while maintaining sampling activity. The calling sequence is as follows:

CALL ADACDR(NSMPLS, IDATA, IWORD, ICHANT)

Where	NSMPLS	number of records to be taken
	IDATA	name of the data array
	IWORD	data record size
	ICHANT	output channel number

TROSMP.MAC  
Single Channel Transient Recorder

This program is used to acquire single channel data both preceding and following a trigger event using the Data Acquisition and Test System, Model 2 (DATS2).<sup>7</sup> The system consists of a Digital Equipment Corporation (DEC) Model PDP-11/03 or LSI-11 computer system<sup>10</sup> with 20K words of semiconductor memory, dual floppy disks, a parallel I/O card, a Texas Instruments Incorporated (TI) Model 745 portable terminal,<sup>12</sup> and an ADAC Corporation Model 600-LSI-11 data acquisition and control system.<sup>11</sup> The ADAC device contains an analog-to-digital converter (ADC) and a pair of digital-to-analog converters (DAC). The sampled data may be displayed on any convenient X-Y display monitor.<sup>13</sup>

Data may be acquired at any of six selectable sample rates from 32 Hz to 1024 Hz. This program executes under DEC's RT-11 operating system as modified to use 24 sectors per track<sup>8</sup> on the floppy disk. The program will operate satisfactorily at or below a 256 Hz sample rate under the standard (26-sector) RT-11 operating system.<sup>14</sup> An empty 24-sector disk can hold a maximum of 55 data records.

Data are taken in a transient recorder (TR) mode of operation. At least one record of data is always recorded prior to the triggering event. Both the trigger and the sampling are interrupt driven. Data transfers to the disk are double buffered in data records of "RCLEN" length. The value of "RCLEN" is given in the assignments section of the source program.

*The output file name and length are entered from the terminal keyboard following suitable prompting messages. The gain for the ADAC is also entered in this fashion. The trigger event is announced with a message as is the end of sampling. Numerous error messages are also available should the need arise.*

It is possible to reexecute the program without repeating the lengthy initial ID and general user information messages. The restart command syntax is different for the single job and the foreground/background monitors and is as follows:

```
SJ START 1000
FB REENTER
```

TRISMP.MAC  
Dual Channel Transient Recorder

This program is used to acquire dual channel data both preceding and following a trigger event using the Data Acquisition and Test System, Model 2 (DATS2).<sup>7</sup> The system consists of a Digital Equipment Corporation (DEC) Model PDP-11/03 or LSI-11 computer system<sup>10</sup> with 20K words of semiconductor memory, dual floppy disks, a parallel I/O card, a Texas Instruments Incorporated (TI) Model 745 portable terminal,<sup>12</sup> and an ADAC Corporation Model 600-LSI-11 data acquisition and control system.<sup>11</sup> The ADAC device contains an analog-to-digital converter (ADC) and a pair of digital-to-analog converters (DAC). The sampled data may be displayed on any convenient X-Y display monitor.<sup>13</sup>

Data may be acquired at any of six selectable sample rates from 16 Hz to 512 Hz. This program executes under DEC's RT-11 operating system as modified to use 24 sectors per track<sup>8</sup> on the floppy disk. The program will operate satisfactorily at or below a 128 Hz sample rate under the standard (26-sector) RT-11 operating system.<sup>14</sup> An empty 24-sector disk can hold a maximum of 27 data records.

Data are taken in a transient recorder (TR) mode of operation. At least one record of data is always recorded for each channel prior to the triggering event. Both the trigger and the sampling are interrupt driven. Data transfers to the disk are double buffered in data records of "RCDLEN" length. The value of "RCDLEN" is given in the assignments section of the source program.

The output file names and lengths are entered from the terminal keyboard following suitable prompting messages. The gain for the ADAC is also entered in this fashion. The trigger event is announced with a message as is the end of sampling. Numerous error messages are also available should the need arise.

It is possible to reexecute the program without repeating the lengthy initial ID and general user information messages. The restart command syntax is different for the single job and the foreground/background monitors and is as follows:

```
SJ START 1000
FB REENTER
```

BSDOUT,MAC  
BISS Data Playback

This program reads BISS data files and outputs the data in real time to a digital-to-analog converter (DAC) used as the Y-axis. A second DAC used as the X-axis is also driven. Both DAC outputs range from +10V to -10V. The DAC outputs are displayed and are also available for external use.

BISS data files consist of an integer number of data records. Each data record contains 2048 data points or samples. Each sample is in 12-bit two's complement form.

Prompting messages guide the operator in making the several keyboard entries. The operator first enters the input file specification. Operator selectable gains of 1, 2, 4, or 8 are available with one being the default value. The operator then chooses 256, 512, or 1024 points per frame with a default of 1024 points per frame. The choice of continuous output or pausing at the end of each frame is available. Continuous real time output is the default. A panel switch on the data acquisition and test system (DATS) allows the choice of plot rates.<sup>7</sup> The available rates are 32, 64, 128, 256, 512, or 1024 points per second. The two highest plot rates require the use of the modified 24-sector monitor and handler.<sup>8</sup> Execution of the program may be aborted by issuing two Control-C's.

The program is designed to execute under the RT-11 operating system on a Digital Equipment Corporation (DEC) Model PDP-11/03 (LSI-11) computer 10, 14, 15 16, 17.<sup>15-17</sup> The two DAC's are part of an ADAC Corporation Model 600-LSI-11 data acquisition and control system.<sup>11</sup> The output is displayed on a Tektronix Incorporated Model 603 storage display monitor.<sup>13</sup>

The following is typical of the terminal input/output when executing this program. The operator's terminal input is underlined.



.R BSDOUT

BSDOUT: BISS DATA OUT  
VERSION 78G10A

ENTER THE INPUT FILE NAME IN THE FOLLOWING FORM:  
<DEV:FILNAM.EXT

\*<DX1:7F12C4

ENTER THE GAIN: 1, 2, 4, OR 8  
\*

ENTER THE POINTS PER FRAME: 256, 512, OR 1024  
\*

ENTER CONTINUOUS OR PAUSE: C OR P

\*P  
\_

PRESS RETURN TO PROCEED  
PRESS RETURN TO PROCEED  
PRESS RETURN TO PROCEED  
PRESS RETURN TO PROCEED

BSDOUT: END OF DATA REACHED

DBSDOT MAC  
Dual Channel BISS Data Playback

This program reads BISS data files and outputs the data in real time to a pair of digital-to-analog converters (DAC). Both DAC outputs range from +10V to -10V. The DAC outputs are available for external use.

BISS data files consist of an integer number of data records. Each data record contains 2048 data points or samples. Each sample is in 12-bit two's complement form.

Prompting messages guide the operator in making the several keyboard entries. The operator first enters the input file specification. Operator selectable gains of 1, 2, 4, or 8 are available with one being the default value. A panel switch on the Data Acquisition and Test System (DATS) allows the choice of plot rates.<sup>7</sup> The available rates are 32, 64, 128, 256, 512, or 1024 points per second. The three highest plot rates require the use of the modified 24-sector monitor and handler.<sup>8</sup> Execution of the program may be aborted by issuing two Control-C's.

The program is designed to execute under the RT-11 operating system on a Digital Equipment Corporation (DEC) Model PDP-11/03 (LSI-11) computer 10, 14, 15 16, 17. The two DAC's are part of an ADAC Corporation Model 600-LSI-11 data acquisition and control system.<sup>11</sup>

The following is typical of the terminal input/output when executing this program. The operator's terminal input is underlined. The default gain is enclosed in brackets.

.R DBSDOT

DBSDOT: DUAL CHANNEL BISS DATA PLAYBACK  
VERSION 78G31A

ENTER THE INPUT FILE NAMES IN THE FOLLOWING FORM:  
<DEV:FILNAM.EXT,DEV:FILNAM.EXT

\*DX1:7K12C4,7K12C5

ENTER THE GAIN:10 2, 4, OR 8  
\*

DBSDOT: END OF DATA REACHED

WDWDAS.MAC  
Real Time Widrow Adaptive Filter

This program functions as a real time nonrecursive adaptive Widrow filter followed by an averaging detector.<sup>18</sup> The algorithm implemented is described by the following equations and diagram 1.

$$E(m) = 16 * ( [1/L] * \sum_{i=0}^{L-1} O(m-i) ) ** 2$$

$$O(m) = \Delta(m) - H(m)$$

$$H(m) = \sum_{n=1}^K [ B(n,m) * S(m-J-n) ]$$

$$B(n,m+1) = Q * [ B(n,m) + [ V * O(m) * S(m-J-n) ] ]$$

where

B(n,m)	dynamic filter coefficients
E(m)	outputs from the detector
O(m)	outputs from the filter
S(m)	signal input samples
J	number of signal time delays
K	number of filter sections
L	number of detector elements
m	sample number
n	filter coefficient number
Q	Ahmed-Jackin coefficient
V	control coefficient

All mathematic operations are performed in fixed point arithmetic using the extended instruction set (EIS) integer instructions.<sup>10</sup> In the following tabulation the binary point is located to the left of the most significant "1" or to the left of the "v." The "1's" indicate significant information to the right of the binary point. The "m's" indicate possible significant information to the left of the binary point. The "0's" indicate the absence of significant information. The "v" indicates a virtual digit that carries no significant information. The sign bit is indicated by an "s." The "p's" and "q's" represent the number of bits to the left and to the right of the binary point, respectively.

Variable	Where	Bit Assignments	p/q
B	Memory	s mmm 111 111 111 111	4/12
E	R5	s mmm 111 111 111 111	4/12
E	Display	s 0mm m11 111 111 111	5/11
H	R0	s mmm 111 111 111 111	4/12
O	R5	s mmm 111 111 111 111	4/12
S	ADAC	s 000 011 111 111 111	5/11
S	Memory	s 111 111 111 110 000	1/15
Q	Memory	s 111 111 111 111 111	1/15
V	Memory	vs 111 111 111 111 111	-1/17
B * S	R4	s mmm 111 111 111 111	4/12
V * O	R0	s mm1 111 111 111 111	3/13
V * O * S	R4	s mmm 111 111 111 111	4/12

When executing on a Digital Equipment Corporation (DEC) Model PDP-11/03 (LSI-11) computer<sup>10</sup> the sample rate with this program is 128 samples per second. The input samples are obtained from an ADAC Corporation Model 600-LSI-11 data acquisition and control system.<sup>11</sup> The ADAC device contains a 12-bit analog-to-digital converter and a pair of 12-bit digital-to-analog converters. The output of the detector is displayed on a Tektronix Incorporated Model 603 storage display monitor<sup>13</sup> at 4096 points per frame. An antialiasing filter should precede the analog-to-digital converter. The filter characteristics should be as follows:

40 Hz cutoff frequency  
12 db per octave rolloff.

The filter coefficients must be modified by the "Q" coefficient to prevent the adaptive filter from adapting to the low level quantization noise that is always present on the input.

The following paragraphs describe the effects of using the several conditional code sets contained in this program. The name of each of the conditional assembly switches appears at the beginning of each paragraph.

DIAG. The output display is changed to 1024 points per frame. Diagnostic code is inserted to count the number of input signal samples, to detect and count overflows and to add threshold detectors and counters for all inputs and outputs. Also, code establishing the number of points per frame is modified to make this value variable via PATCH or ODI. A 100-word block of memory is reserved for patching.

FAKE. The real time read routine is replaced to permit operation from data stored in memory.

FILE. The real time read routine is replaced to permit input from a file and output to a file. The signal and output file names are entered from the console keyboard during initializing.

RCRD. Code is added to rcrd both the input to the filter and the output from the averaging detector. The file names are entered from the console keyboard during initialization. Minimum and maximum file lengths are as follows:

Memory	Records	Blocks	Time
12K	1	8	16 seconds
16K	2	16	32 seconds
20K	3	24	48 seconds
24K	4	32	64 seconds
28K	5	40	80 seconds

NSCP. Code addressing the display registers is disabled to permit execution on the PDP-11/34 which has no such device.

TIME. An instruction to clear the X-axis DAC is issued at the end of each pertinent module for execution time measuring purposes. This instruction is also issued twice at the end of each pass through the program.

SKVS. The code is modified to run in a memory only machine with no RT-11 operating system and no terminal.

WGHT. Code is added to record the filter weights or coefficients following the processing of each 64th sample. If the file space required exceeds the capacity of the floppy disk also use the conditional "NDSP=1." This will permit execution on the PDP-11/34 with its larger disks. When using this "WGHT=1" conditional the number of filter sections must not exceed 64. This is specified when using the conditional "CNFG=1" with the label "SECTNS". The "TIME=1" conditional may not be used if both the "WGHT=1" and the "NDSP=1" conditionals are used.

JSSSE. The adaptive filter requires the input of an impulse function once each "2\*K" samples to prevent it from adapting to the low level quantization noise that is always present on the input. This is in lieu of the "Q" coefficient.

PRTM. Code is included to cause the time of day to be printed on the console terminal for each alarm that is detected. The date is also printed with the first detected alarm following a midnight rollover.

Schematic Diagram

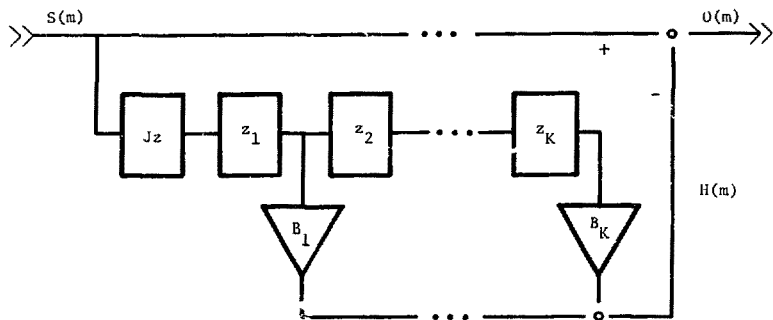

Diagram 1



TRNSFR.MAC  
Real Time Adaptive Transfer Filter

This program functions as a real time nonrecursive adaptive transfer filter.<sup>3</sup> The filter weights for the signal filter are copied from those of the reference filter. The algorithm implemented is described by the following equations and diagram 2.

$$O(m) = S(m-C) - H(m)$$

$$H(m) = \sum_{n=1}^K [ B(n,m) * S(m-C-J-n) ]$$

$$B(n,m+1) = B(n,m) + [ V * E(m) * R(m-D-I-n) ]$$

$$E(m) = R(m-D) - G(m)$$

$$G(m) = \sum_{n=1}^K [ B(n,m) * R(m-D-I-n) ]$$

where

B(n,m)	dynamic filter coefficients
E(m)	outputs from the predictor
O(m)	outputs from the filter
R(m)	reference input samples
S(m)	signal input samples
C	number of signal time delays outside the filter loop
D	number of reference time delays outside the filter loop
I	number of reference time delays inside the filter loop
J	number of signal time delays inside the filter loop
K	number of filter sections
m	sample number
n	filter coefficient number
V	control coefficient

All mathematic operations are performed in fixed point arithmetic using the extended instruction set (EIS) integer instructions.<sup>10</sup> In the following tabulation the binary point is located to the left of the most significant "1" or to the left of the "v." The "1's" indicate significant information to the right of the binary point. The "m's" indicate

significant information to the left of the binary point. The "0's" indicate the absence of significant information. The "v" indicates a virtual digit that carries no significant information. The sign bit is indicated by an "s." The "p's" and "q's" represent the number of bits to the left and to the right of the binary point, respectively.

Variable	Where	Bit Assignments	p/q
B	Memory	s mmm 111 111 111 111	4/12
E	R5	s mmm 111 111 111 111	4/12
G	Stack	s mmm 111 111 111 111	4/12
H	Stack	s mmm 111 111 111 111	4/12
O	Display	s 0mm ml1 111 111 111	5/11
O	R5	s mmm 111 111 111 111	4/12
R	ADAC	s 000 011 111 111 111	5/11
R	Memory	s 111 111 111 110 000	1/15
S	ADAC	s 000 011 111 111 111	5/11
S	Memory	s 111 111 111 110 000	1/15
V	Memory	vs 111 111 111 111 111	-1/17
B * R	R4	s mmm 111 111 111 111	4/12
B * S	R4	s mmm 111 111 111 111	4/12
V * E	Stack	s mml 111 111 111 111	3/13
V * E * R	R4	s mmm 111 111 111 111	4/12
V * E * S	R4	s mml 111 111 111 111	3/13

When executing on a Digital Equipment Corporation (DEC) Model PDP-11/03\* (LSI-11) computer<sup>10</sup> the sample rate with this program is 128 samples per second. Since samples are taken on alternate clock pulses for the signal and the reference inputs, the clock must be set to run at twice the sample rate. The input samples are obtained from an ADAC Corporation Model 600-LSI-11 data acquisition and control system.<sup>11</sup> The signal is on channel one and the reference is on channel two. The ADAC device contains a 12-bit analog-to-digital converter and a pair of 12-bit digital-to-analog converters. The output of the filter is displayed on a Tektronix Incorporated Model 603 storage display monitor<sup>13</sup> at 4096 points per frame.

The following paragraphs describe the effects of using the several conditional code sets contained in this program. The name of each of the conditional assembly switches appears at the beginning of each paragraph.

DIAG. Diagnostic code is inserted to count the number of input signal samples, to detect and count overflows, and to add threshold detectors and counters for all inputs and outputs. Also, code establishing the display magnitude and the number of points per frame is modified to make these values variable via PATCH or ODT. A 100-word block of memory is reserved for patching. The sample rate must be reduced below 128 Hz.

FAKE. The real time read routines are replaced to permit operation from data stored in memory. Separate buffers of data are supplied for the signal and the reference.

FILE. The real time read routines are replaced to permit input from files and output to a file. The signal, reference and output file names are entered from the console keyboard during initialization. The output display is changed to 1024 points per frame.

Schematic Diagram

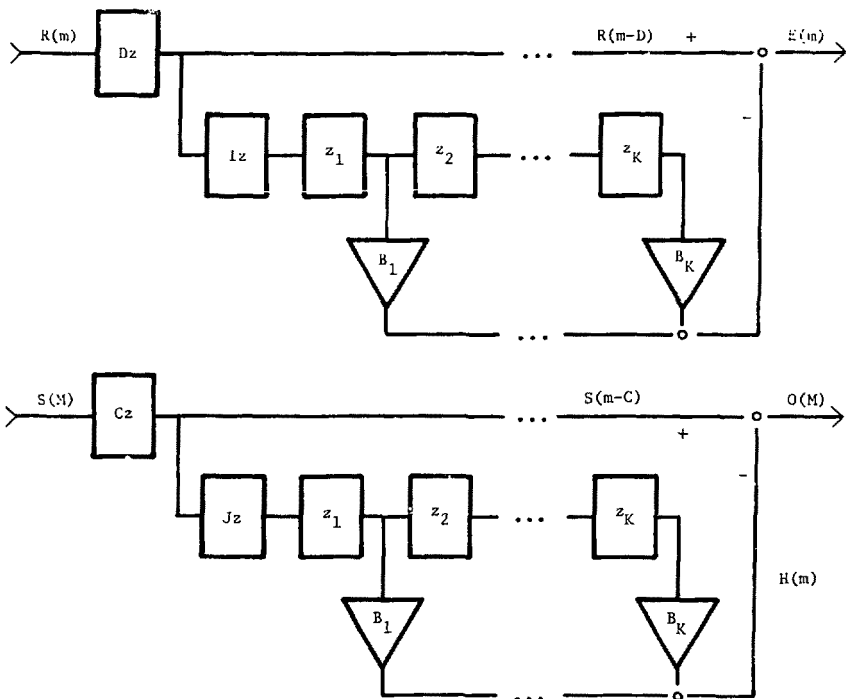

Diagram 2

AFMATD.MAC  
 Real Time Adaptive Filter,  
 Moving Average Filter and  
 Adaptive Threshold Detector

This program functions as a real time nonrecursive adaptive filter (ADF) followed by a moving average filter (MAF) and an adaptive threshold detector (ATD).<sup>1,2</sup> The algorithm implemented is described by the following expressions and by diagrams 3, 4, 5 and 6.

```

If P(m)  Theta
then     E(m) = 1 - 2**-11
else     E(m) = 0

P(m) = [ W0 * C(m-1) ] + [ W1 * C(m) ]

G(m) = A(m) - C(m-D)

C(m) = [ ( TK / F ) * Summation A(m-i) ]
        i=0

A(m) = ( |1/L| * Summation [ O(m-i) ] ) ** 2
        i=0

O(m) = S(m) - H(m)

H(m) = Summation [ B(n,m) * S(m-J-n) ]
        n=1

B(n,m+1) = Q * [ B(n,m) + [ V * O(m) * S(m-J-n) ] ]

where  A(m)  outputs from moving average filter
        B(n,m) ATD coefficients
        C(m)  internal ATD value
        E(m)  outputs from ATD
        O(m)  outputs from ADF
        S(m)  signal input samples
        Theta ATD offset
        TK   ATD threshold constant
        W0, W1 ATD filter coefficients
        D    number of ATD delays
        F    number of ATD elements
  
```

J        number of ADF delays  
 K        number of ADF sections  
 L        number of MAF and ATD elements  
 m        sample number  
 n        ADF coefficient number  
 Q        Ahmed-Jacklin coefficient  
 V        ADF feedback control coefficient

All mathematic operations are performed in fixed point arithmetic using the extended instruction set (EIS) integer instructions.<sup>10</sup> In the following tabulation the binary point is located to the left of the most significant "1" or to the left of the "v." The "1's" indicate significant information to the right of the binary point. The "m's" indicate possible significant information to the left of the binary point. The "0's" indicate the absence of significant information. The "v" indicates a virtual digit that carries no significant information. The sign bit is indicated by an "s." The "p's" and "q's" represent the number of bits to the left and to the right of the binary point, respectively.<sup>18</sup>

Variable	Where	Bit Assignments	p/q
A	R1	s mmm 111 111 111 111	4/12
B	Memory	s mmm 111 111 111 111	4/12
E	R5	s mmm m11 111 111 111	5/11
H	R0	s mmm 111 111 111 111	4/12
O	Memory	s mmm 111 111 111 111	4/12
Q	Memory	s 111 111 111 111 111	1/15
S	ADAC	s 000 011 111 111 111	5/11
S	Memory	s 111 111 111 110 000	1/15
Theta	Memory	s mmm 111 111 111 111	4/12
TK	Memory	s mmm m11 111 111 111	5/11
W0, W1	Memory	s 111 111 111 111 111	1/15
V	Memory	vs 111 111 111 111 111	-1/17
B * S	R4	s mmm 111 111 111 111	4/12
V * O	R0	s mml 111 111 111 111	3/13
V * O * S	R4	s mmm 111 111 111 111	4/12

The "p's" and "q's" resulting from the arithmetic instructions in this program are as shown below. For all operations:

$$p + q = p_1 + q_1 = p_2 + q_2 = 16.$$

## Addition and Subtraction

$$\begin{aligned} p &= p1 + p2 \\ q &= q1 - q2 \end{aligned}$$

## Multiplication

$$\begin{aligned} p &= p1 * p2 \\ q &= q1 * q2 - 16 \end{aligned}$$

## Division

$$\begin{aligned} p &= p1 / p2 \\ q &= q1 / q2 + 16. \end{aligned}$$

When executing on a Digital Equipment Corporation (DEC) Model PDP-11/03\* (LSI-11) computer<sup>10,15,17</sup> the sample rate with this program is 128 samples per second. The input samples are obtained from an ADAC Corporation Model 600-LSI-11 data acquisition and control system.<sup>11</sup> The ADAC device contains a 12-bit analog-to-digital converter and a pair of 12-bit digital-to-analog converters. The input signal and the outputs of the ADF, MAF, and ATD are displayed on a Tektronix Incorporated Model 603 storage display monitor<sup>13</sup> at 1024 points per trace. An antialiasing filter should precede the analog-to-digital converter. The filter characteristics should be as follows:

40 Hz cutoff frequency  
12 db per octave rolloff.

The following paragraphs describe the effects of using the several conditional code sets contained in this program. The name of each of the conditional assembly switches appears at the beginning of each paragraph.

DIAG. Diagnostic code is inserted to count the number of input signal samples and to detect and count overflows. A 100-word block of memory is reserved for patching.

DIAG. Diagnostic code is inserted to count the number of input signal samples and to detect and count overflows. A 100-word block of memory is reserved for patching.

FAKE. The real time read routine is replaced to permit operation from data stored in memory.

FILE. The real time read routine is replaced to permit input from a file and output to a file. The signal and output file names are entered from the console keyboard during initializing.

RCRD. Code is added to record both the input to the filter and the output from the averaging detector. The file names are entered from the console keyboard during initialization. Minimum and maximum file lengths are as follows:

Memory	Records	Blocks	Time
12K	1	8	16 seconds
16K	2	16	32 seconds
20K	3	24	48 seconds
24K	4	32	64 seconds
28K	5	40	80 seconds

NDSP. Code addressing the display registers is disabled to permit execution on the PDP-11/34 which has no such device.

TIME. An instruction to clear the X-axis DAC is issued at the end of each pertinent module for execution time measuring purposes. This instruction is also issued twice at the end of each pass through the program.

SKVS. The code is modified to run in a memory only machine with no RT-11 operating system and no terminal.

WGHT. Code is added to record the filter weights or coefficients following the processing of each 64th sample. If the file space required exceeds the capacity of the floppy disk also use the conditional "NDSP=1".



This will permit execution on the PDP-11/34 with its larger disks. When using this "WGHT=1" conditional the number of filter sections must not exceed 64. This is specified when using the conditional "CNFG=1" with the label "KKKK." The "TIME=1" conditional may not be used if both the "WGHT=1" and the "NDSP=1" conditionals are used.

JSSS. The adaptive filter is given an impulse function once each "2\*K" samples to prevent it from adapting to the low level quantization noise that is always present. This is in lieu of the "Q" coefficient.

PRTM. Code is included to cause the time of day to be printed on the console terminal for each alarm that is detected. The date is also printed with the first detected alarm following startup and subsequent midnight rollovers.

Block Diagram



Diagram 3

ADF Schematic Diagram

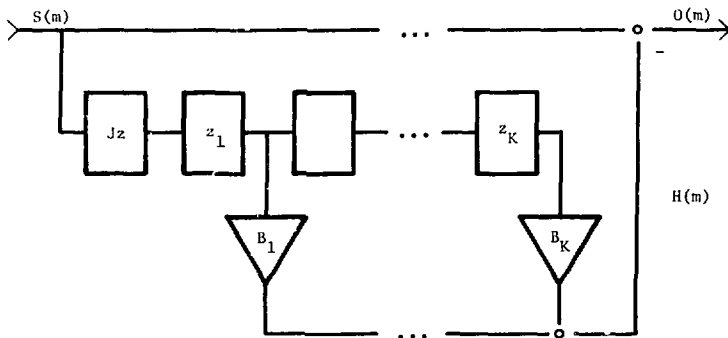

Diagram 4

MAF Schematic Diagram

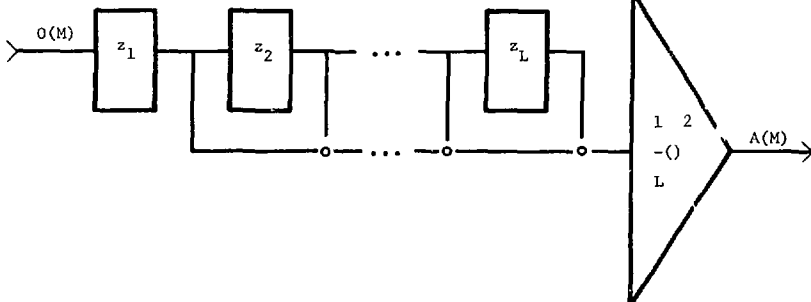

Diagram 5

ATD Schematic Diagram

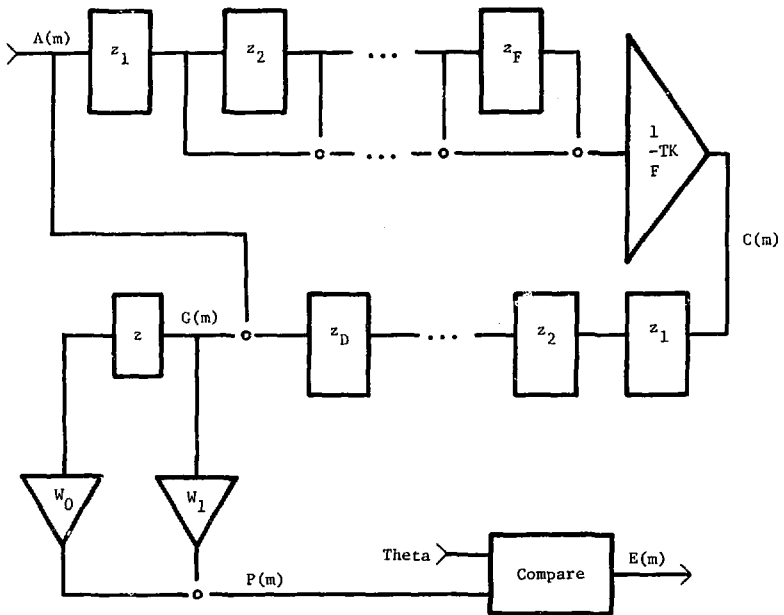

Diagram 6

.SPDUVL.MAC  
Real Time SSPDU II Monitor

This program is used to record the dual channel analog signal data being processed by the Dual Channel Sensor Signal Processor Development Unit (SSPDU II)<sup>9</sup> using the Data Acquisition and Test System, Model 2 (DATS2)<sup>7</sup>. The program also records SSPDU II status data either on command from SSPDU II or from DATS2. The program is terminated after recording an operator-determined number of SSPDU II and/or DATS2 initiated triggers. It may also be aborted at any time by the operator without loss of any data by issuing double Control-C. The sampled signal data may be displayed on any convenient X-Y display monitor.<sup>13</sup>

The program is written in Digital Equipment Corporation's (DEC) PDP-11 MACRO-11 assembly language.<sup>10,15,17</sup> It is designed to execute under the RT-11 V03 operating system using the foreground/background monitor.<sup>14,16</sup>

Each recording Command results in the recording of one signal data record and one status data record. The channel 0 and 1 commands record signal and status data for channels 0 and 1, respectively. The snapshot command records signal and status data for both channels. The signal data are recorded in the standard DATS integer format. This format consists of records of 2048 samples where each sample is a right justified 12-bit two's complement integer. The signal data are recorded in transient recorder mode such that the recording command or trigger always occurs during the second half of the signal's data record. The status data are recorded in records of 256 16-bit words. The contents of the status data are given in Table I.<sup>19</sup> Each word of this status data is made up as follows:

Bits 15-4	Data, two's complement integer
Bits 3-1	not used
Bit 0	Validity indicator

The data are all recorded in files on floppy disks. It is not necessary, although desirable, to start with an initialized (empty) disk. However, the disk must be in a compressed or "SQUEEZEd" condition. The file names for the signal and status data are the same for a given channel. The file name extension for signal data is ".DAT" and for status data is ".STS." The output file names and lengths are entered from the console keyboard following suitable prompting messages. The gain for the analog-to-digital converter (ADAC) is also entered in this fashion. Trigger events are indicated by printing the number of unrecorded records (alarms) remaining for each channel on the terminal. Program termination is identified with a message. Following program termination the data disk is "SQUEEZEd" and its directory is printed on the console terminal. Numerous error messages are also available should the need arise. A block diagram of the system appears in diagram 7.

TABLE I  
Status Data

<u>Word</u>	<u>Source</u>	<u>Description</u>
0	SSPDU	ADF delays (J)
1-16	SSPDU	ADF B coefficients
17	SSPDU	ADF B coefficients scale factor
18	SSPDU	ADF V coefficients
19	SSPDU	ADF V coefficients scale factor
20	SSPDU	ADF Q coefficients
21	SSPDU	ADF Q coefficients scale factor
22	SSPDU	MAF elements (L)
23	SSPDU	ATD elements (F)
24	SSPDU	ATD delays (D)
25	SSPDU	ATD offset (TK)
26	SSPDU	ATD offset scale factor
27	SSPDU	ATD threshold (Theta)
28	SSPDU	ATD threshold scale factor
29-31	SSPDU	ATD not defined
32	DATS	ATD Alarm Trigger date bits 14-10 month bits 9-5 day bits 4-0 year - 72.
33-34	DATS	Alarm trigger time high order word 33 low order word 34
35	DATS	Integer sample count from start of record to trigger
36	DATS	Trigger source 0=SSPDU (alarm) 1=DATS (snapshot)
37	DATS	Integer sample rate in Hz
38	DATS	Program start up date bits 14-10 month bits 9-5 day bits 4-0 year - 72.
39-40	DATS	Program start up time high order word 39 low order word 40
41-255	DATS	not defined

Note: RT-11 does not support month and year rollover.

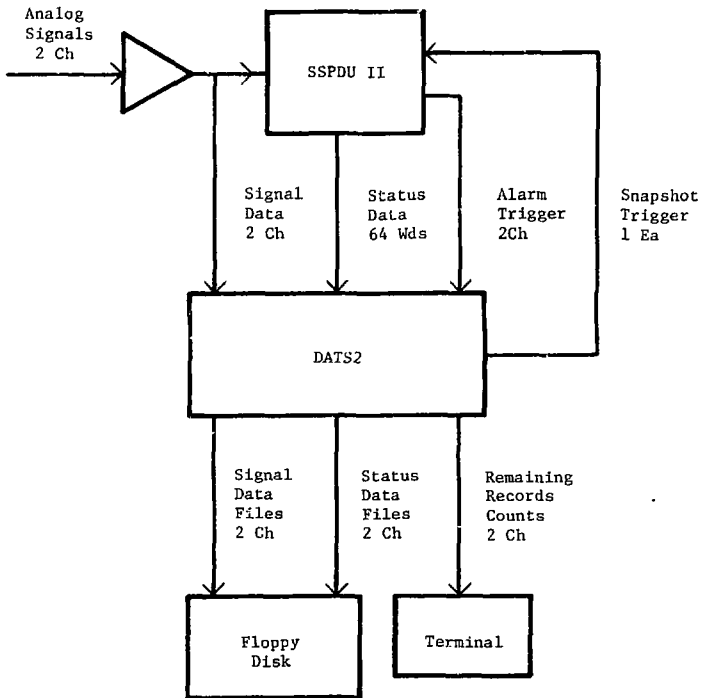

Diagram 7

The following is typical of the terminal input/output when executing this program. The operator's terminal input is underlined.

.R SPDUVL

SPDUVL: SSPDU II DATA ACQUISITION  
VERSION 78G06A

SAMPLE RATE	CLOCK RATE	TIME WINDOW
Hz	Hz	MIN:SEC/RCD
128	256	0:16
64	128	0:32
32	64	1:04
16	32	2:08

EACH RECORD CONTAINS 2048 SAMPLES

SET THE CLOCK AND ENTER THE SAMPLE RATE

\*128

ENTER THE 1-6 CHARACTER FILE NAME FOR CHANNEL 0

\*8G06A0

ENTER THE 1-6 CHARACTER FILE NAME FOR CHANNEL 1

\*8G06A1

ENTER THE NUMBER OF ALARMS: 1, 2, ... , 25 OR 26

\*3

ENTER THE ADAC GAIN: 1, 2, 5 OR 10

\*1

DISK SPACE REMAINING

CH0/CH1

3/3

3/2

3/1

2/1

2/0

SPDUVL: PROGRAM TERMINATING

06-Jul-78

8G06A0.DAT 8 06-Jul-78 8G06A1.DAT 24 06-Jul-78

8G06A0.STS 1 06-Jul-78 8G06A1.STS 3 06-Jul-78

<UNUSED> 444

4 Files, 36 Blocks

444 Free Blocks



## References

1. G. R. Elliott, W. L. Jacklin, S. D. Stearns, "The Adaptive Digital Filter," SAND76-0360, Sandia Laboratories, Albuquerque, NM 87185, Aug 76.
2. N. Ahmed, letter to G. R. Elliott, Kansas State University, Manhattan, KA 66505, 20-Aug 76.
3. G. R. Elliott, S. D. Stearns, N. Ahmed, "Adaptive Transfer Filter Considerations," Conference Record, Eleventh Asilomar Conference on Circuits, Systems and Computers, Nov 77.
4. N. Ahmed, "A Study of Adaptive Digital Filters," SAND77-0102, Sandia Laboratories, Albuquerque, NM 87185, Aug 77.
5. G. R. Elliott, "Selective Digital Filtering," SAND77-1297, Sandia Laboratories, Albuquerque, NM 87185, Nov 77.
6. N. Ahmed, "On Intrusion-Detection Via Adaptive Prediction," SAND77-1591, Sandia Laboratories, Albuquerque, NM 87185, Apr 78.
7. R. P. Kromer, "A Small Portable Data Acquisition System," SAND77-1845C, Sandia Laboratories, Albuquerque, NM 87185, Dec 77.
8. N. A. Bourgeois, Jr. "24-Sector Floppy Disk System," SAND77-0228, Sandia Laboratories, Albuquerque, NM 87185, Jan 77.
9. J. E. Simpson, "Preliminary Design Definition for the Dual Input Processor Module, Phase I," unpublished, Sandia Laboratories, Albuquerque, NM 87185, 7 Mar 76.
10. "Microcomputer Handbook," second edition, EB 07948, Digital Equipment Corporation, Maynard, MA 01754, 1977.
11. "Instruction Manual for Data Acquisition and Control System," 600-LSI-11, ADAC Corporation, Woburn, MA 01754.
12. "Model 745 Portable Data Terminal Operating Instructions," 984024-9701, Texas Instruments Incorporated, Houston, TX 77001, 15 Dec 75.
13. "Instruction Manual, 603/604 Monitor," 070-1259-01, Tektronix Incorporated, Beaverton, OR 97005, Jul 76.
14. "Software Product Description, DEC 11 XPDAS-G-D, Digital Equipment Corporation, Maynard, MA 01754, Aug 77.
15. "PDP11 MACRO-11 Language Reference Manual," AA-50775A-TC, Digital Equipment Corporation, Maynard, MA 01754, Aug 77.
16. "RT-11 System User's Guide," DEC-11-ORGDA-A-D, Digital Equipment Corporation, Maynard, MA 01754, Aug 77.

17. "RT-11 Advanced Programmer's Guide," DEC-11-ORAPA-A-D, Digital Equipment Corporation, Maynard, MA 01754, Oct 77.
18. N. A. Bourgeois, Jr. "The Software Development of a Real Time Signal Processing System," SAND77-1684, Sandia Laboratories, Albuquerque, NM 87185, Dec 77.
19. J. E. Simpson, "SSPDU II Status Data Formats," unpublished, Sandia Laboratories, Albuquerque, NM 87185, 27 Jul 78.

DISTRIBUTION:

HEADQUARTERS (3)  
ESD/MCB/STOP 36  
HANSCOM AFB, MA 01731  
ATTN: CUL. R. T. KOZUMA, OCB  
LT. COL. P. E. PECO, OCBE  
B. ALLEN, OCBE

HEADQUARTERS  
ROME AIR DEVELOPMENT CENTER (AFCS)  
GRIFFISS AFB, NY 13441  
ATTN: R. ALLEN, OCDS

US ARMY MOBILITY EQUIPMENT RESEARCH AND DEVELOPMENT COMMAND  
FT. BELVOIR, VA 22060  
ATTN: D. KEEHAN, DRXFB-XS

NAVAL UNDERSEA CENTER (2)  
SAN DIEGO, CA 92132  
ATTN: J. RFDERN  
J. ZIEDLER

INSTITUTE FOR COMPUTER SCIENCES AND TECHNOLOGY  
US DEPARTMENT OF COMMERCE  
NATIONAL BUREAU OF STANDARDS  
WASHINGTON, DC 20234  
ATTN: R. T. MOORE, CHIEF  
COMPUTER SYSTEMS SECTION

DEPARTMENT OF THE NAVY  
NAVAL COASTAL SYSTEMS LABS  
PANAMA CITY, FL 32401  
ATTN: R. FORBUS

DIRECTOR  
DEFENSE NUCLEAR AGENCY  
WASHINGTON, DC 20305  
ATTN: M. BEASLEY, NSSO

KANSAS STATE UNIVERSITY  
DEPARTMENT OF ELECTRICAL ENGINEERING  
MANHATTAN, KS 66506  
ATTN: N. SIMMED

NEW MEXICO STATE UNIVERSITY  
DEPARTMENT OF COMPUTER SCIENCE  
LAS CRUCES, NM 88003  
ATTN: D. DEARHOLT

1000	G. A. FOWLER
1111	S. D. STEARNS (15)
1241	R. N. HORTON
1426	A. J. ROTH
1483	D. M. MORRISON
1521	J. L. MORILEY
1523	F. I. MAGEE
1523	R. E. TRELLE
1554	N. J. POLLARD
1584	T. M. SCHULTHEIS
1700	W. C. MYRE
1710	V. E. BLAKE, JR.
1730	C. H. MAUNEY
1730A	R. K. PETERSEN
1731	E. R. JULIUS
1732	R. P. SYLER
1733	T. J. HOBAN, JR.
1734	W. N. CAUDLE
1736	D. C. HANSON
1736	N. A. BOURGEOIS, JR. (6)
1736	G. W. DONOHOE
1736	G. R. ELLIOTT (15)
1736	R. J. GOSSETT
1736	W. L. JACKLIN
1736	R. P. KROMER
1736	L. W. MASCHOFF
1736	J. E. SCHEIBNER
1736	J. E. SIMPSON
1736	R. A. WAYNE
1739	J. D. WILLIAMS
1750	J. E. STIEGLER
1759	M. J. EATON
1760	J. JACOBS
2351	T. C. BRYANT, JR.
2355	D. H. JENSEN
2532	R. A. HAYENGA
2534	R. W. ROBERTS
2627	R. M. JAMES
2648	L. F. TOLENDINO
2648	T. M. UNKELHAEUSER
4722	B. STIEFELD
5613	J. H. GRAHAM
8450	D. N. TANNER
8266	E. A. AAS
3141	T. L. WERNER (5)
3151	W. L. GARNER (3)

FOR DOE/TIC (UNLIMITED RELEASE)

DOE/TIC (25)

(R. P. Campbell, 3172-3)