

Wahab, Lisa and Katebi, Reza (2010) Data-driven adaptive model-based predictive control with application to wastewater systems. IET Control Theory and Applications . ISSN 1751-8644

<http://strathprints.strath.ac.uk/27489/>

This is an author produced version of a paper published in IET Control Theory and Applications . ISSN 1751-8644. This version has been peer-reviewed but does not include the final publisher proof corrections, published layout or pagination.

Strathprints is designed to allow users to access the research output of the University of Strathclyde. Copyright © and Moral Rights for the papers on this site are retained by the individual authors and/or other copyright owners. You may not engage in further distribution of the material for any profitmaking activities or any commercial gain. You may freely distribute both the url (<http://strathprints.strath.ac.uk>) and the content of this paper for research or study, educational, or not-for-profit purposes without prior permission or charge. You may freely distribute the url (<http://strathprints.strath.ac.uk>) of the Strathprints website.

Any correspondence concerning this service should be sent to The Strathprints Administrator: eprints@cis.strath.ac.uk

**Data-driven Adaptive Model-Based Predictive Control with
Application to Wastewater Systems**

Journal:	<i>IET Control Theory & Applications</i>
Manuscript ID:	CTA-2010-0068.R2
Manuscript Type:	Regular Paper
Date Submitted by the Author:	n/a
Complete List of Authors:	Abdul Wahab, Norhaliza; Universiti Teknologi Malaysia, Electrical Engineering
Keyword:	Adaptive Control, Model Predictive Control, Process Control, System Identification

SCHOLARONE™
Manuscripts

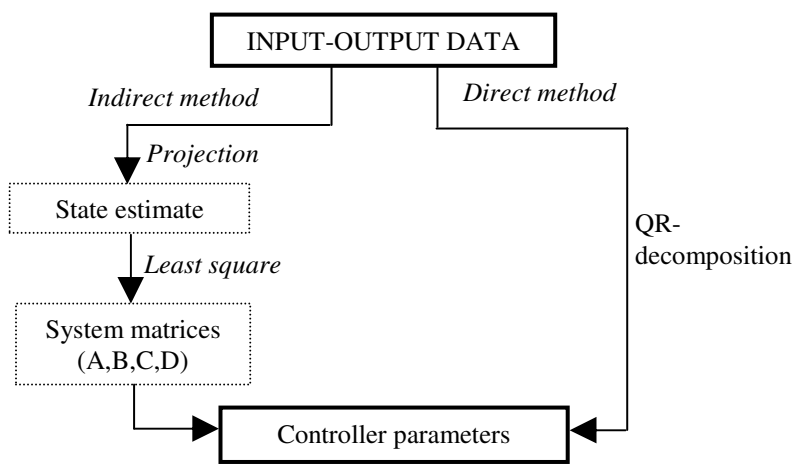

Fig. 1: Comparison between direct and indirect methods

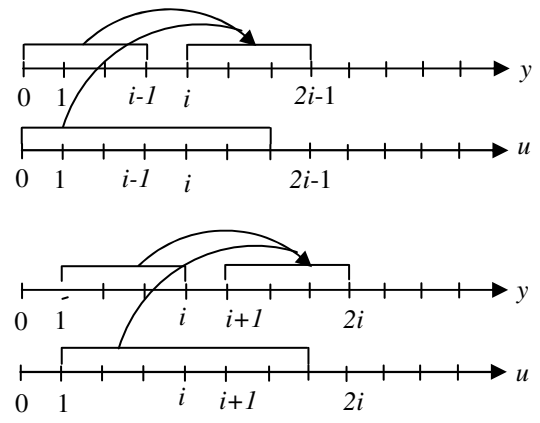

Fig. 2: Sliding window for $i=4$

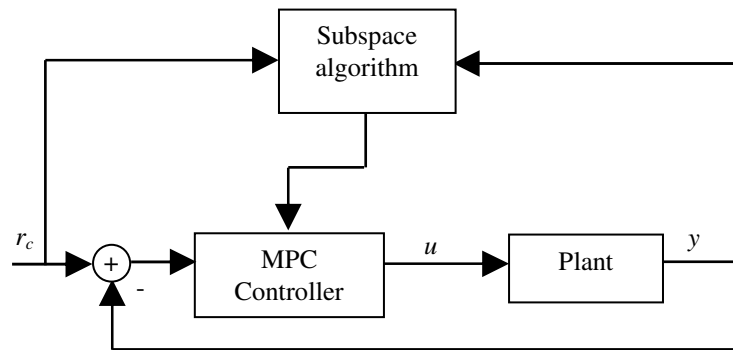

Fig. 3: Direct Adaptive Control

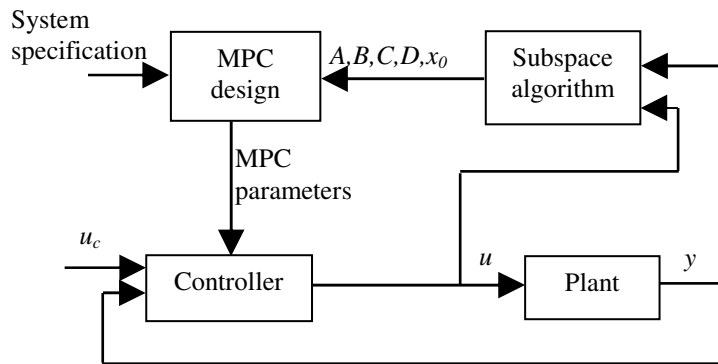

Fig. 4: Indirect Adaptive Control

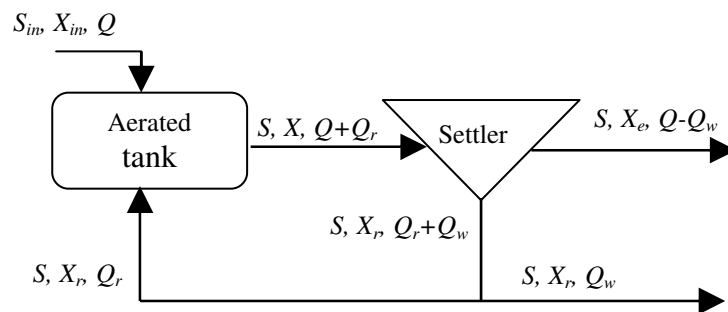

Fig. 5: Activated Sludge Reactor

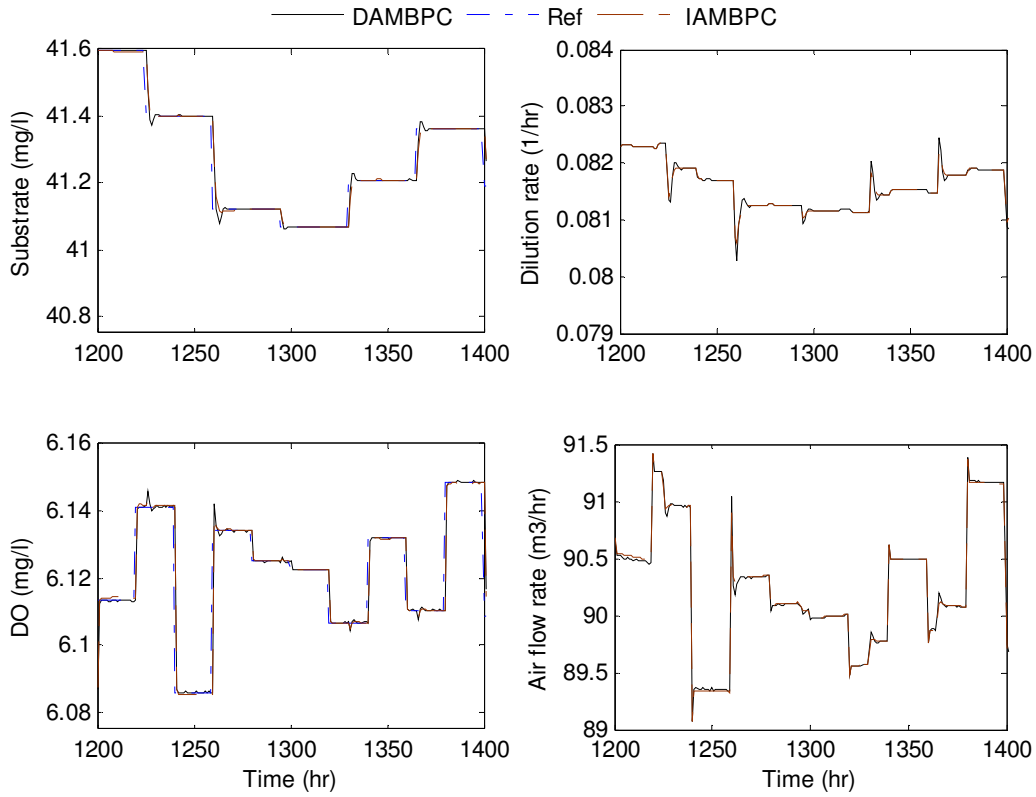

Fig. 6 : Performance comparison between DAMBPC and IAMBPC: set point tracking

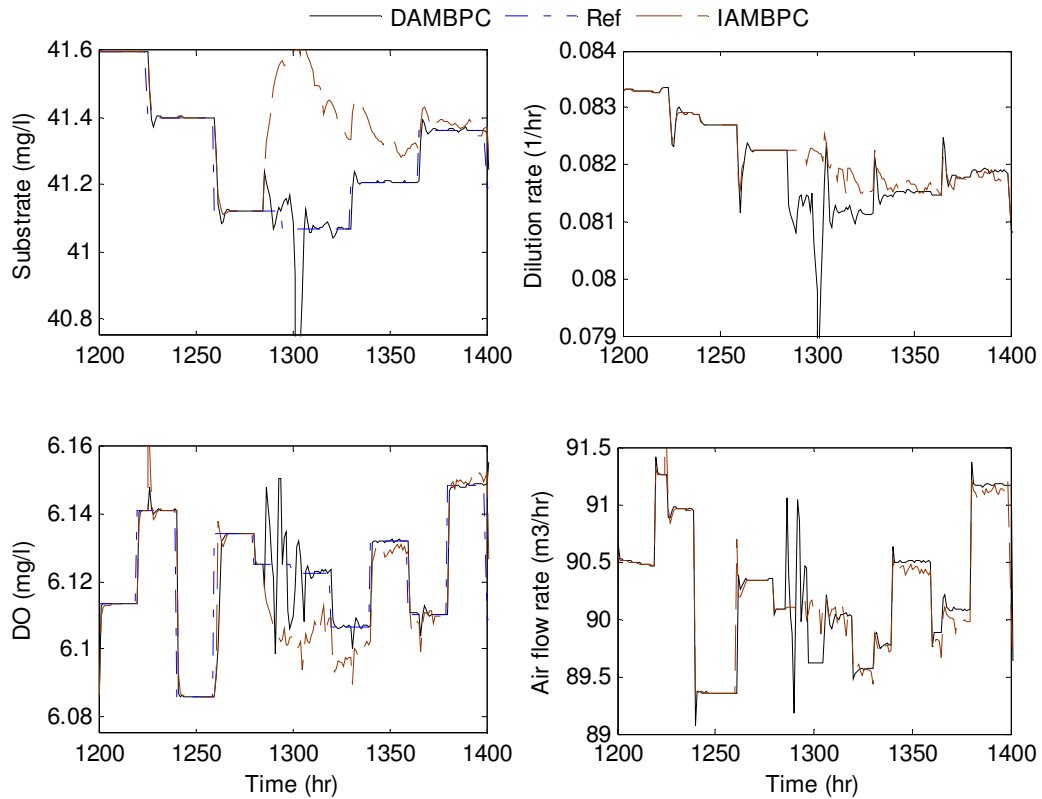
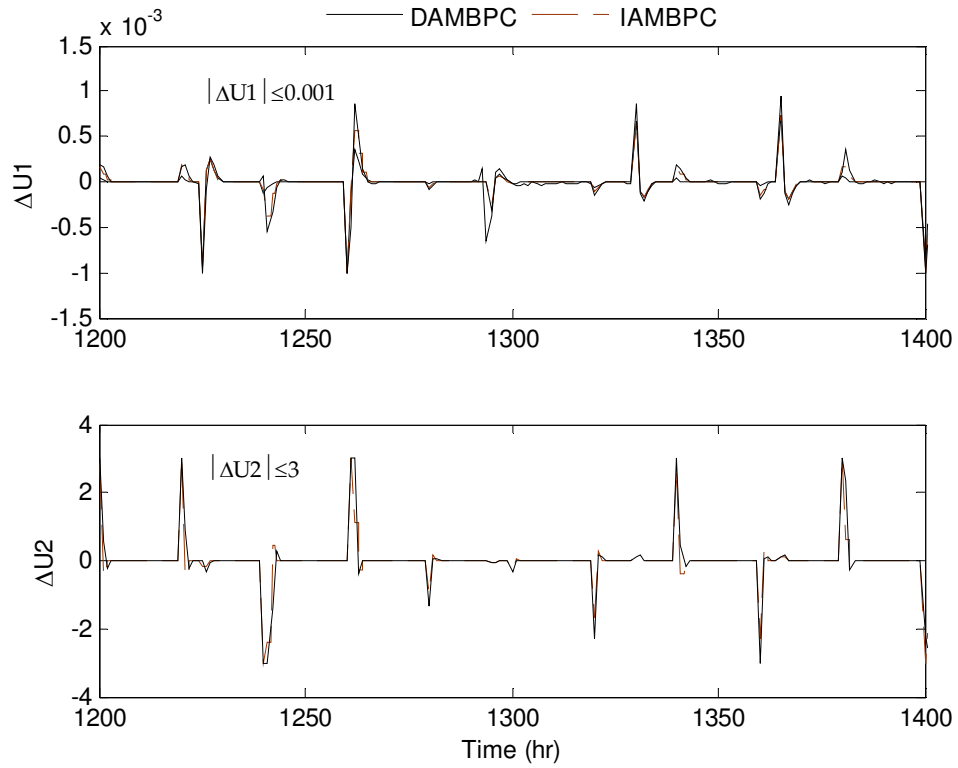
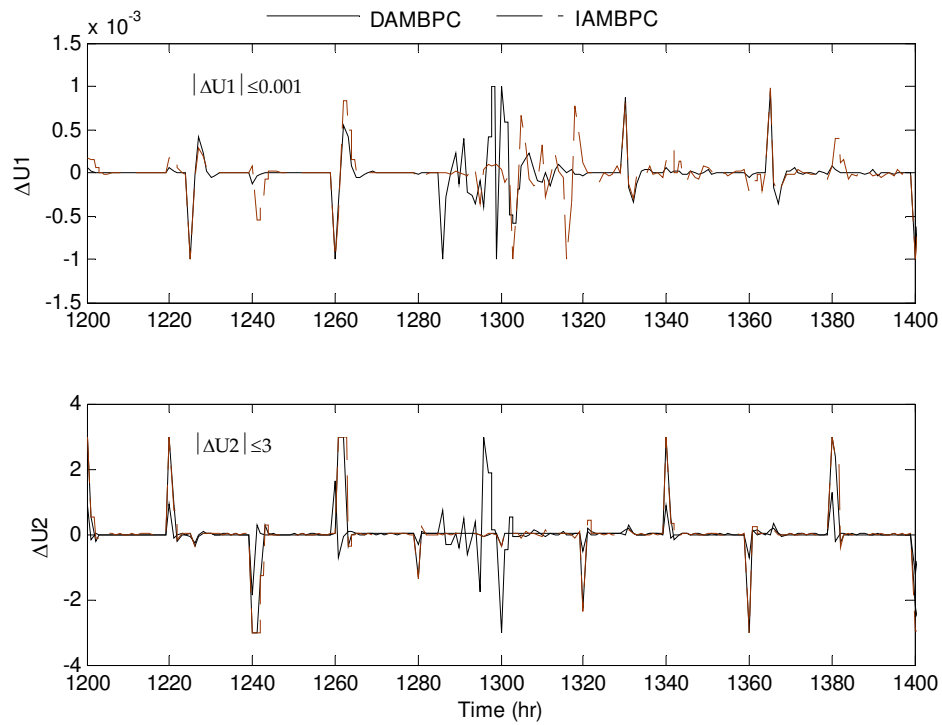

Fig. 7: Performance comparison between DAMBPC and IAMBPC: disturbance rejection



(a) Set point tracking



(b) Disturbance rejection

Fig.8: Performance comparison for increment input responses

Data-driven Adaptive Model-Based Predictive Control with Application to Wastewater Systems

Norhaliza A Wahab^{a*}, Reza Katebi^b, Jonas Balderud^c, M. Fuaad Rahmat^a

^a *Department of Control and Instrumentation Engineering, Faculty of Electrical Engineering, Universiti Teknologi Malaysia, Johor, Malaysia*

^b *Industrial Control Centre, Dept of Electronic and Electrical Engineering, University of Strathclyde, Glasgow, UK*

^c *Outokumpu Stainless AB, SE-693 81 Degerfors, Sweden*

Abstract: This paper is concerned with the development of a new data-driven adaptive model-based predictive controller (MBPC) with input constraints. The proposed methods employ subspace identification technique and a Singular Value Decomposition (SVD) based optimisation strategy to formulate the control algorithm and incorporate the input constraints. Both Direct Adaptive Model-Based Predictive Controller (DAMBPC) and Indirect Adaptive Model-Based Predictive Controller (IAMBPC) are considered. In DAMBPC, the direct identification of controller parameters is desired to reduce the design effort and computational load whilst the IAMBPC involves a two-stage process of model identification and controller design. The former method only requires a single QR decomposition for obtaining the controller parameters and uses a receding horizon approach to process input/output data for the identification. A suboptimal SVD-based optimisation technique is proposed to incorporate the input constraints. The proposed techniques are implemented and tested on a 4th order nonlinear model of a wastewater system. Simulation results are presented to compare the direct and indirect adaptive methods and to demonstrate the performance of the proposed algorithms.

Keywords: Activated sludge process, Adaptive control, Model-based predictive control, Subspace identification.

1. Introduction

The classical control design problem is to start with building a model of the systems using physical laws to derive a presentation of the system in forms such as transfer function, matrix fraction, state space, impulse response, etc. While this approach works well for many systems, it has several disadvantages. The process of model building is expensive and cumbersome. Moreover, the models are valid only for a limited operating range and hence cannot capture the time varying or nonlinear behavior of many dynamic systems. As a consequence, many solution methods and algorithms were developed to design more effective controllers. The gain scheduling controllers were formally introduced in the sixties [1], followed by adaptive control approach in the seventies [2], neuro-fuzzy controllers in the eighties [2] and H-infinity robust control design in the nineties [3]. Most of these methods were however model-based and hence requires expensive effort to develop accurate models. Data driven methods use the process input/output data to design a stabilizing controller with satisfactory performance. This can include many of the adaptive control algorithms as well as neuro-fuzzy control design techniques. The data driven approach allows the controller to be designed using data from the actual system to be controlled under realistic operating conditions. Hence, the controller will stabilize the actual system instead of a model of that system. This procedure avoids the needs for modeling the plant under all hypothetical disturbances, and operating conditions, but considers only those that actually occur. A good background and application of data driven control are presented in [4] and [5], respectively.

This paper demonstrates the use of subspace-based techniques for the implementation of indirect and direct adaptive model-based predictive controller with input constraints. Subspace identification techniques have emerged as one of the more popular identification methods for the estimation of state space models. Using these techniques, subspace matrices, which obtained directly from input/output data, are used to obtain prediction of the process outputs. These predictions can subsequently serve as a basis for MBPC design. By continuously updating these predictions models, an adaptive predictive control method can be obtained. In IAMBPC, the controller is designed in two separate steps of model identification and control design. A more attractive alternative to the two-step method is to estimate the control parameters directly from the measurements (*i.e.* DAMBPC). The direct adaptive control method was developed in the early 70s [6] and widely deployed because of low computation requirement as it combines system identification and control design.

Some previous work has been reported on the design of MBPC using data driven control design method such as model-free Linear Quadratic Gaussian (LQG) and subspace predictive controller [7; 8; 9; 10], or controller designs using the state space model identified through subspace approach [11; 12]. It is shown in [7; 8] that the system identification and the calculation of controller parameters may be replaced by a single QR decomposition and hence a data driven controller can be formulated. Although the idea of combined subspace methods and MBPC as a data driven control design method has been around for few years, designing an adaptive subspace-based MBPC is still an open area of research. Existing methods in subspace-based adaptive MBPC does not include constraints [10], and hence one of the main attraction of predictive control design technique is missing from these methods. Therefore, the objective of this paper is to develop subspace based adaptive MBPC, which includes input constraints, as well as soft nonlinear dynamics. Wang et al. [14] have also employed similar approach but their work differs in term of the identification approach for the design of subspace controller, (e.g. the prediction of the future outputs presented by the past available measurements and past input signals.). Moreover, this paper highlights the advantage of using a suboptimal SVD-based optimisation technique to incorporate the input constraints as compared to QP method. Other approaches for dealing with these types of processes include nonlinear MBPC [13] and neural network based MBPC approaches [14]. The latter method has made few inroads in practice due to its complexity and computational load typically associated with these methods. For industrial applications, however, multiple model linear MBPC approaches tend to be more favoured [15; 16].

The proposed direct adaptive MBPC method can offer an attractive alternative to existing methods for slowly time-varying and nonlinear systems. The method combines the simplicity of linear MBPC with the power of a self-tuning controller to incorporate the hard input constraints. The main advantages are that the usually tedious and time-consuming modelling task can be relaxed and the controller can adapt to changing process conditions while the physical constraints are satisfied. The use of an SVD based method for optimisation reduces the computation burden and ensures that a solution can be found in a desired sampling time. The performance of DAMBPC is compared with IAMBPC using a 4th order nonlinear model of a wastewater system. Simulation results are presented to investigate the effect of prediction horizon on the tracking and disturbance rejection properties of the proposed algorithms.

The paper is organised as follows: Section 2 briefly recapitulates the main concepts of subspace identification and QR decomposition. The proposed constrained adaptive model-based predictive control approach is developed in Section 3, both for DAMBPC and IAMBPC methods. Section 4 describes the application of the proposed method to an activated sludge wastewater treatment plant. Section 5 presents the

simulation results where the performances of the proposed control strategies are compared. The paper ends with some conclusion.

2. The subspace identification method

A linear discrete time-invariant state space system can be represented as:

$$x(k+1) = Ax(k) + Bu(k) + Kv(k) \quad (1)$$

$$y(k) = Cx(k) + Du(k) + v(k) \quad (2)$$

where $u(k)$, $y(k)$ and $x(k)$ are the inputs, outputs and states respectively and $v(k)$ is a white noise sequence with zero-mean and variance $E[v_p v_q^T] = S \delta_{pq}$. A, B, C, D and K are system matrices with appropriate dimensions. We assume that (A, B) is controllable and (C, A) is observable. The following matrix input-output equations [17] play an important role in the problem treated in linear subspace identification and it can be obtained by recursive substitution of Eq. (1) into Eq. (2):

$$Y_f = \Gamma_i X_f + H_i U_f \quad \text{and/or} \quad Y_p = \Gamma_i X_p + H_i U_p \quad (3)$$

where the data block Hankel matrices for $u(k)$ represented as U_p and U_f defined as:

$$U_p = \begin{pmatrix} u_0 & u_1 & \cdots & u_{j-1} \\ u_1 & u_2 & \cdots & u_j \\ \vdots & \vdots & \ddots & \vdots \\ u_{i-1} & u_i & \cdots & u_{i+j-2} \end{pmatrix} \quad (4)$$

$$U_f = \begin{pmatrix} u_i & u_{i+1} & \cdots & u_{i+j-1} \\ u_{i+1} & u_{i+2} & \cdots & u_{i+j} \\ \vdots & \vdots & \ddots & \vdots \\ u_{2i-1} & u_{2i} & \cdots & u_{2i+j-2} \end{pmatrix} \quad (5)$$

The subscripts p and f represent ‘past’ and ‘future’ time. The outputs block Hankel matrices Y_p and Y_f can also be defined in the same way. i is the prediction horizon (or so called H_p). Then, the data set is broken into j prediction problem. The following shorthand notation is used for the past input-output data:

$$W_p = \begin{pmatrix} U_p \\ Y_p \end{pmatrix} \quad (6)$$

The future state sequence is defined as:

$$X_f = (x_i \quad x_{i+1} \quad \cdots \quad x_{i+j-1})^T \quad (7)$$

The extended observability matrix, Γ_i and the lower block triangular Toeplitz matrix, H_i are defined as:

$$\Gamma_i = \begin{pmatrix} C \\ CA \\ \vdots \\ CA^{i-1} \end{pmatrix}, \quad H_i = \begin{pmatrix} CB & 0 & \cdots & 0 \\ CAB & CB & \cdots & 0 \\ \vdots & \vdots & \ddots & \vdots \\ CA^{i-1}B & CA^{i-2}B & \cdots & CB \end{pmatrix} \quad (8)$$

The basic idea of subspace identification method is that, from the previously defined matrix input-output Eq. (3), it can be observed that the block data Hankel matrix containing the future outputs, Y_f is linearly related to the future state sequences, X_i and the future inputs, U_f . Therefore, the main framework of subspace model identification is to recover the term $\Gamma_i X_f$, whereby from the knowledge of either Γ_i or X_f , the state space system matrices can be retrieved in a least square sense [18]. Once the system parameters are obtained, they can be used to design the controller.

This identification method is implemented for IAMBPC where the state space system matrices are obtained using online subspace identification algorithm, i.e. Numerical algorithms for Subspace State Space System IDentification (N4SID). For the DAMBPC controller parameters (subspace matrices) are directly derived from the input-output measurement. The difference between two approaches is schematically shown in Fig. 1. The following derivation is focused only for identifying the subspace matrices for the DAMBPC method. The detail derivation on the subspace identification and the use of projection in subspace identification are not presented here. They can be found in [18].

In the case when no noise is present, the actual future output Y_f lies in the combined row space and the linear predictor equation can be written as:

$$\hat{Y}_f = L_w W_p + L_u U_f \quad (9)$$

where W_p and U_f are the past inputs and outputs and future inputs, respectively. L_w and L_u are subspace matrices corresponding to the states and inputs, respectively. By solving the following least square problem, the output prediction, \hat{Y}_f can be extracted:

$$\min_{L_w, L_u} \left\| Y_f - (L_w, L_u) \begin{pmatrix} W_p \\ U_f \end{pmatrix} \right\|_F^2 \quad (10)$$

The orthogonal projection of the row space of Y_f into the row space spanned by W_p and U_f applied in Eq. (10) gives:

$$\hat{Y}_f = Y_f / \left(\begin{matrix} W_p \\ U_f \end{matrix} \right) \quad (11)$$

$$\hat{Y}_f = \underbrace{Y_f /_{L_w} W_p}_{L_w} + \underbrace{Y_f /_{L_u} U_f}_{L_u} \quad (12)$$

from which we have two projections involved in the right hand side in the above equations. The first projection of $Y_f /_{L_w} W_p$ relates to Kalman filter state of the system and the second projection of $Y_f /_{L_u} U_f$ relates to Toeplitz matrix. Now, Eq. (12) can be solved efficiently via QR decomposition:

$$\begin{pmatrix} W_p \\ U_f \\ Y_f \end{pmatrix} = \begin{pmatrix} R_{11} & 0 & 0 \\ R_{21} & R_{22} & 0 \\ R_{31} & R_{32} & R_{33} \end{pmatrix} \begin{pmatrix} Q_1^T \\ Q_2^T \\ Q_3^T \end{pmatrix} \quad (13)$$

By posing:

$$L = \begin{pmatrix} R_{31} & R_{32} \end{pmatrix} \begin{pmatrix} R_{11} & 0 \\ R_{21} & R_{22} \end{pmatrix}^\dagger \quad (14)$$

where $L = (L_w \quad L_u)$ and \dagger denotes the Penrose-Moore pseudo inverse, Eq. (12) can be written as:

$$\hat{Y}_f = Y_f / \left(\begin{matrix} W_p \\ U_f \end{matrix} \right) = L \begin{pmatrix} W_p \\ U_f \end{pmatrix} \quad (15)$$

where L_w and L_u in Eq. (12) can be obtained by partitioning L in Eq. (15):

$$\begin{bmatrix} L_w & L_u \end{bmatrix} = Y_f \begin{bmatrix} W_p \\ U_f \end{bmatrix}^+ \quad (16)$$

$$\begin{bmatrix} L_w & L_u \end{bmatrix} = Y_f \begin{bmatrix} W_p^T & U_f^T \end{bmatrix} \left(\begin{bmatrix} W_p \\ U_f \end{bmatrix} \begin{bmatrix} W_p^T & U_f^T \end{bmatrix} \right)^{-1} \quad (17)$$

where N_u and N_y denote the number of input and output, respectively. It can be observed that, the subspace matrices L_w and L_u can be retrieved directly from matrix R . The system matrices A, B, C, D do not have to be calculated explicitly. To enable an adaptive sliding window, QR-updating is performed. A combination of updating and down dating the QR decomposition is performed making use of the rank-one modification [19]. The subspace matrices are updated online throughout the updated R factor from the implemented QR updating.

As mentioned previously, the most interesting part in subspace model identification is that we can obtain Kalman filter state directly from input-output data without having knowledge of system

parameters. The link between Kalman filtering and the projection of the future outputs Y_f into the combined row space of the past inputs and outputs W_p and the future inputs U_f is demonstrated in Eq. (12). We can now exploit the duality between Kalman filter and MBPC controller. For $i, j \rightarrow \infty$, we obtain:

$$Y_f /_{U_f} W_p = L_w W_p = \Gamma_i \hat{X}_f \quad (18)$$

$$L_u = H_i \quad (19)$$

In general, L_w correspond to the determination of Kalman filter state and L_u represents the controller parameters. It can be seen that there is a link between subspace projection and the Kalman filter estimates, \hat{X}_f of the state sequence X_f given by Eq. (18). When L_w is approximated to a lower order matrix using singular value decomposition, it would be a rank deficient matrix of order n if there were no noise. This description gives $L_w \approx U_1 \Sigma_1 V_1^T$. Therefore, for $\Gamma_i \approx U_1 \Sigma_1^{1/2}$ and $\hat{X}_f \approx \Sigma_1^{1/2} V_1^T W_p$:

$$\begin{aligned} \Gamma_i \hat{X}_f &= U_1 \Sigma_1^{1/2} \cdot \Sigma_1^{1/2} V_1^T W_p \\ &= U_1 \Sigma_1 V_1^T W_p \\ &= L_w W_p \end{aligned} \quad (20)$$

where $\hat{X}_f = \hat{x}_1$ is the steady state Kalman filter estimate and Γ_i is the extended observability matrix.

To obtain offset-free tracking, an integral action is included. Previous works that include integrator in the design of subspace controller are given in [9; 11]. The matrix input-output in Eq. (3) can be changed to include an integrator in the predictor and this can be expressed as follows:

$$\Delta Y_f = \tilde{\Gamma}_i S_f + \tilde{H}_i \Delta U_f \quad (21)$$

$$\Delta \hat{Y}_f = \tilde{\Gamma}_i S_f + \tilde{H}_i \Delta U_f \quad (22)$$

and

$$\Delta \hat{Y}_f = \tilde{L}_w \Delta W_p + \tilde{L}_u \Delta U_f \quad (23)$$

where \tilde{L}_w and \tilde{L}_u are obtained directly from the previous identification of L_w and L_u . Thus:

$$\hat{Y}_f = Y_t + \tilde{L}_w \Delta W_p + \tilde{L}_u \Delta U_f \quad (24)$$

where the current output Y_t has the same dimension as prediction horizon and is defined as:

$$Y_i = [y_i \quad y_i \quad \cdots \quad y_i]^T \quad (25)$$

It should be noted that in any closed-loop parameter identification scheme, the input signal should be persistently exciting to perturb the main dynamics of the system. This can be usually achieved by injecting a Pseudo Random Binary Sequence Signal (PRBS) at the process set points. In practice for adaptive control algorithm, a degree of perturbation and excitation are also achieved during the identification and control design as the controller parameters changes as the control design is updated.

3. Adaptive Model-Based Predictive Control

The adaptive control scheme investigated here uses subspace identification technique described above. The measured data is collected over a sliding (receding) window. The procedure of using a sliding window for identification is illustrated in Fig. 2. Note that, data window used to identify subspace predictor parameters should be expressed in term of future inputs $u_f = (u_{i-1} \quad \dots \quad u_{2i-2})^T$ and measurement (past) inputs $u_p = (u_0 \quad \dots \quad u_{i-1})^T$ and outputs $y_p = (y_0 \quad \dots \quad y_{i-1})^T$ as described in Eq. (9). Here, the two prediction problems should be solved at current time instant i and $i+1$ as shown in Fig. 2. The first prediction problem ($t=i$) represents the case for obtaining the optimal prediction of i future outputs $\hat{y}_f = (\hat{y}_i \quad \dots \quad \hat{y}_{2i-1})^T$ using the information given in the previously stated data window u_p , y_p and u_f . The second prediction problem shows that the time instant slides ($t=i$ to $t=i+1$) and similar meaning can be observed, only difference is the data window (u_p , y_p and u_f), which is, now slides from left to right. At every time step, for the new input-output data obtained, the subspace predictor parameters are updated online and the new control action is computed. Note that, the linear predictor in Eq. (24) is directly driven by input-output data and contains an integral action. The main advantage of this approach is that the controller parameters are updated at each sample time, which usually means a quicker response to process changes. The main drawback of this method is that a QR-decomposition needs to be computed at each sample instance, which increases the computation load.

In the constraint case, the computational burden is an important issue to be considered. The constrained control problem is usually solved using standard Quadratic Programming (QP) method. This requires heavy computational effort and hence is not suitable for online adaptive control design scheme. To reduce the computational load, an SVD based strategy is proposed here [20]. The structure of the

performance index is exploited using SVD analysis within the context of subspace adaptive frameworks. We Two methods of subspace adaptive control scheme (DAMBPC and IAMBPC) are developed for the constrained case using SVD analysis

3.1. Direct method (DAMBPC)

A possible structure for direct adaptive control using MBPC is depicted in Fig. 3. To implement the DAMBPC, consider the linear predictor equation given in Eq. (24):

$$\hat{y}_f = \tilde{L}_w w_p + \tilde{L}_u \Delta u_f \quad (26)$$

The following MBPC performance index is minimised to calculate the control input increment, Δu_f :

$$\begin{aligned} J &= \sum_{i=1}^{H_p} (r(k+i) - y(k+i))^T Q (r(k+i) - y(k+i)) + \sum_{i=0}^{H_c-1} \Delta u(k+i)^T R \Delta u(k+i) \\ &= (r_f - \hat{y}_f)^T Q (r_f - \hat{y}_f) + \Delta u_f^T R \Delta u_f \end{aligned} \quad (27)$$

where H_p and H_c denote the prediction horizon and control horizon, respectively. The output and input weighting matrices are $Q = \text{diag}(Q_1 \mathbf{1} \dots Q_{H_p}) > 0$ and $R = \text{diag}(R_1 \mathbf{1} \dots R_{H_c} - 1) \geq 0$. Substituting Eq. (26) into Eq. (27) gives:

$$J = (r_f - \tilde{L}_w w_p - \tilde{L}_u \Delta u_f)^T Q (r_f - \tilde{L}_w w_p - \tilde{L}_u \Delta u_f) + \Delta u_f^T R \Delta u_f \quad (28)$$

where $r_f - \tilde{L}_w w_p = e$ is the tracking error, thus:

$$J = e^T Q e - 2 \Delta u_f^T \tilde{L}_u^T Q e + \Delta u_f^T \Omega \Delta u_f \quad (29)$$

where $\Omega = \tilde{L}_u^T Q \tilde{L}_u + R \in \mathbf{R}^{H_c N_u \times H_c N_u}$. To find the minimum of J , its derivative is set to zero:

$$\frac{\partial J}{\partial \Delta u_f} = 0 \quad (30)$$

The DAMBPC control law is therefore defined as:

$$\Delta u_f = \Omega^{-1} \tilde{L}_u^T Q e \quad (31)$$

Eq. (31) gives the unconstrained optimal solution and the controller parameter \tilde{L}_u is directly obtained from experimental data.

The implementation of SVD based optimisation for the constrained case is discussed next. This makes the adaptive control scheme considerably faster and easier to implement as compared to QP method, since the Hessian Ω can be formed directly from the identification step. At each sampling instant, a feasible control sequence is determined by selecting a variable subset of the SVD basis representation. This sequence defined as Δu satisfies the gain and rate input constraints of the optimisation problem (Eq. (29)) defined as $u(k)^{\min} \leq u(k) \leq u(k)^{\max}$ and $\Delta u(k)^{\min} \leq \Delta u(k) \leq \Delta u(k)^{\max}$.

To calculate the control input, let the SVD of Ω be defined as [18]:

$$\Omega = U\Sigma V^T = U\Sigma U^T = V\Sigma V^T \quad (32)$$

where $\Sigma \in \mathbb{R}^{H_c N_u \times H_c N_u}$ is given as:

$$\Sigma = \begin{pmatrix} \sigma_1 & 0 & \dots & 0 \\ 0 & \sigma_2 & \dots & 0 \\ \vdots & \vdots & \ddots & \vdots \\ 0 & 0 & \dots & \sigma_{H_c N_u} \end{pmatrix} \quad (33)$$

and $\sigma_1 \geq \sigma_2 \geq \dots \geq \sigma_{H_c N_u} \geq 0$. The σ_i are the singular values of Σ and the vectors u_i and v_i are the i^{th} left singular vector and the i^{th} right singular vector, respectively. In this case, since Ω is symmetric, the left and right singular vectors are identical. This in turn, yields an important property that is the singular vector matrix V is orthogonal *i.e.* $V^T V = V V^T = I_{H_c N_u}$. If $V = (v_1, \dots, v_{H_c N_u})$ is orthogonal, then the v_i form an orthonormal basis vector for $\mathbb{R}^{H_c N_u}$. Therefore, the following control input increment vectors:

$$\Delta u = (\Delta u(k) \quad \Delta u(k+1) \quad \dots \quad \Delta u(k+H_c-1))^T \quad (34)$$

can be expressed as a linear combination of the singular vectors, v_i of Ω given as:

$$\Delta u = V \Delta \tilde{u} = \sum_{i=1}^{H_c N_u} v_i \Delta \tilde{u}_i \quad (35)$$

where $v_i = (v_1, \dots, v_{H_c N_u})$ are the columns of V , and $\Delta \tilde{u}_i$ are the entries of the input increment vector $\Delta \tilde{u}$.

The performance index, J , can now be written in terms of the new increment input vectors as:

$$J = e^T Q e - 2 \Delta \tilde{u}^T V^T \tilde{L}_u^T Q e + \Delta \tilde{u}^T \Sigma \Delta \tilde{u} \quad (36)$$

This gives the optimal unconstrained control input increment sequence:

$$\Delta \tilde{u}_{uc} = \Sigma^{-1} V^T \tilde{L}_u^T Q e \quad (37)$$

The increment input vectors for the constrained case can be constructed by considering the modification of the unconstrained solution, $\Delta\tilde{u}_{uc}$ in Eq. (37). Let us first define the performance index, J as:

$$\min_{\Delta u} J = J_{uc} + \sum_{i=1}^{H_c N_u} \sigma_i \left(\Delta\tilde{u}_i - \Delta\tilde{u}_{uc,i} \right)^2 \quad (38)$$

where $\Delta\tilde{u}_{uc,i}$ is the i^{th} entry of vector $\Delta\tilde{u}_{uc}$. From Eq. (38), it can be observed that whenever $\Delta\tilde{u}_i = \Delta\tilde{u}_{uc,i}$, we obtain $J = J_{uc}$, which is the unconstrained value. Note that the entries of Δu in Eq. (38) are arranged in decreasing order of magnitude, since $\sigma_1 \geq \sigma_2 \geq \dots \geq \sigma_{H_c N_u} \geq 0$, which starting from the one that influences the performance index the most and ending with the one that influences the performance index the least.

Therefore, to find a feasible solution to the constrained optimisation problem J , we need to consider the components in the entries of vector $\Delta\tilde{u}_{uc}$ with highest contribution in reducing the magnitude of J , i.e. use those elements of $\Delta\tilde{u}_{uc}$ with the biggest singular values. $\Delta\tilde{u}_{uc}$ for the unconstrained solution is:

$$\Delta u_{uc} = V \Delta\tilde{u}_{uc} = \sum_{i=1}^{H_c N_u} v_i \Delta\tilde{u}_{uc,i} \quad (39)$$

The vector $\Delta\tilde{u}_{uc}$ in Eq. (37) will be ordered from the highest to the smallest singular values and progressively discarding smaller components, until the constraints are satisfied, i.e.:

$$\Delta u_{uc} = V \left(\Delta\tilde{u}_{1,uc} \quad \dots \quad \Delta\tilde{u}_{m,uc} \quad 0 \quad \dots \quad 0 \right)^T \quad (40)$$

where $m \in I_{H_c N_u} \square \{1 \quad \dots \quad H_c N_u\}$. This does not necessarily gives the best control performance, hence the following control increment vector is defined:

$$\Delta u_{svd} = \sum_{i=1}^m v_i \Delta\tilde{u}_{i,uc} + \left(v_{m+1} \alpha \Delta\tilde{u}_{m+1,uc} \right) \quad (41)$$

where $0 \leq \alpha \leq 1$ and $m \in I_{H_c N_u} \square \{1 \quad \dots \quad H_c N_u\}$. To obtain the best solution α should be as large as possible while the constraints are satisfied. For $m = H_c N_u$, $\alpha = 0$ and the solution is unconstrained. The proposed SVD-based DAMBPC is summarised here:

Algorithm 3.1 (Direct method)

Step 1: Construct data block Hankel matrix, i.e. U_β , U_p , Y_p , Y_f from a given input-output data.

Step 2: Compute L by using Eq. (14), then partitioning L into L_w and L_u using Eqs. (16) and (17).

Step 3: Compute unconstrained solution, i.e. $\Delta\tilde{u}_{uc} = \Sigma^{-1} V^T \tilde{L}_u^T Q e$

Step 4: Find the ‘‘largest’’ $\theta = m + \alpha$, where $0 \leq \alpha \leq 1$ such that the vector:

$$\Delta u_{svd} = V \Delta \tilde{u}_{svd} = V \left(\Delta \tilde{u}_{1,uc} \quad \dots \quad \Delta \tilde{u}_{m,uc} \quad \alpha \Delta \tilde{u}_{m+1,uc} \quad 0 \quad \dots \quad 0 \right)^T$$

lies on the boundary of the constraint set in $\square^{H_c N_u}$ and $\Delta u_{svd} \in \Delta \square$. The parameters m and α are tuned for the best performance whilst the constraints are satisfied

Step 5: At time k , only $\Delta u_{svd}(1)$ is implemented and the calculation is repeated at each time instant, i.e.

$$u(k) \text{ is implemented as: } u(k) = u(k-1) + \Delta u(k)$$

Step 6: Update the Hankel matrix using the newest data and go to step 2 and repeat.

3.2. Indirect method (IAMBPC)

For IAMBPC, the classical two-step of system identification and control design is performed. Firstly, a suitable model is estimated using subspace algorithm and then the controller parameters are calculated from a design method as shown in Fig. 4. The Numerical Algorithm for Subspace State Space System IDentification (N4SID) [20] is employed here for process identification.

By iterating the model in Eq. (1) - (2), the prediction output is defined as:

$$\hat{y}_f = \Gamma x + H \Delta u \quad (42)$$

The quadratic performance index can be expressed as follows:

$$J = e^T Q e - 2 \Delta u^T H^T Q e + \Delta u^T \square \Delta u \quad (43)$$

where $\square = H^T Q H + R \in \square^{H_c N_u \times H_c N_u}$ and $e = r_f - \Gamma x$. The IAMBPC control law can be found by making the gradient of J zero, therefore:

$$\Delta u = \square^{-1} H^T Q e \quad (44)$$

By using SVD-based strategy, the performance index, J can now be rewritten as:

$$J = e^T Q e - 2 \Delta \tilde{u}^T V^T H^T Q e + \Delta \tilde{u}^T \Sigma \Delta \tilde{u} \quad (45)$$

Thus, the unconstrained optimal Δu is:

$$\Delta \tilde{u}_{uc} = \Sigma^{-1} V^T H^T Q e \quad (46)$$

The derivation of the constrained solution using SVD-based optimisation strategy is similar to the one described in Section 3.1 and it is not repeated here. The IAMBPC algorithm is summarised here.

Algorithm 3.2: Indirect method

Step 1: Construct data block Hankel matrix, i.e. U_f, U_p, Y_p, Y_f from a given input-output data.

Step 2: Compute the matrices A, B, C, D by solving the least square problem.

Step 3: Compute the optimal unconstrained solution $\Delta \tilde{u}_{uc} = \Sigma^{-1} V^T H^T Q e$

Step 4 – 6: Similar to Algorithm 3.1

4. Control of Activated Sludge Processes (ACT)

In this study, the proposed methods are applied to control a nonlinear activated sludge wastewater treatment plant. This process comprises an aerated tank and a settler as shown in Fig. 5. The bioreactor includes a secondary clarifier that serves to retain the biomass in the system while producing a high quality effluent. Part of the settled biomass is recycled to allow the right concentration of microorganisms in the aerated tank. A component mass balance that yields the following set of nonlinear differential equations was used [22]:

$$\dot{X}(t) = \mu(t)X(t) - D(t)(1+r)X(t) + rD(t)X_r(t) \quad (47)$$

$$\dot{S}(t) = -\frac{\mu(t)}{Y}X(t) - D(t)(1+r)S(t) + D(t)S_{in} \quad (48)$$

$$C(t) = \frac{K_o \mu(t) X(t)}{Y} - D(t)(1+r)C(t) + K_{La}(C_s - C(t) + D(t)C_{in}) \quad (49)$$

$$\dot{X}_r(t) = D(t)(1+r)X(t) - D(t)(\beta+r)X_r(t) \quad (50)$$

where the state variables, $X(t)$, $S(t)$, $C(t)$ and $X_r(t)$ represent the concentrations of biomass, substrate, dissolved oxygen (DO) and recycled biomass respectively. $D(t)$ is the dilution rate, while S_{in} and C_{in} correspond to the substrate and DO concentrations of influent stream. The parameters r and β represent the ratio of recycled and waste flow to the influent flow rate, respectively. The kinetics of the cell mass production is defined in terms of the specific growth rate μ and the yield of cell mass Y . The term K_o is a constant. C_s and K_{La} denote the maximum DO concentration and the oxygen mass transfer coefficient, respectively. The quantity (W) appears in Eq. (49) through the oxygen transfer rate coefficient K_{La} :

$$K_{La} = \rho W \quad (51)$$

where $\rho > 0$. The Monod equation gives the growth rate related to the maximum growth rate, to the substrate concentration, and to DO concentration:

$$\mu(t) = \mu_{max} \frac{S(t)}{K_s + S(t)} \frac{C(t)}{K_c + C(t)} \quad (52)$$

where μ_{max} is the maximum specific growth rate, K_s is the affinity constant and K_c is the saturation constant.

In this simulation, two controlled outputs substrate (S) and DO and two manipulated inputs dilution rate (D) and airflow rate (W) are considered. The sampling rate of the MBPC controller and the activated sludge process is chosen as $T_s=1$ hr.

An adaptive control design scheme is required for this process as the dynamic is nonlinear and time varying. This is usually caused by the variation in the concentration and composition of the influent to the plant as well as 24-hrs changes in the influent flow. The process exhibits different dynamic under varying weather of dry, rain or storm conditions as well as variation in the daily temperature.

5. Evaluation and simulation results

Simulations were carried out for the two proposed control strategies that is, DAMBPC and IAMBPC methods. Both control methods use sliding identification window to update the parameters. The objective of the control algorithm is to regulate the substrate and DO concentrations from a steady state operating point at outputs 41.23 mg/l and 6.11 mg/l, respectively. For a fair comparison of both methods, the horizons are set to $H_p = 20$ and $H_c = 5$. The weighting matrices were chosen as $Q = \text{diag}(1,10)$ and $R = \text{diag}(10^4, 10^{-4})$. The length of window is set to $n=400$. The constraints on the input change were allowed to be $|\Delta U_1| \leq 0.001$ and $|\Delta U_2| \leq 3.0$.

Fig. 6 compares the set point tracking performance of the two control strategies. It can be seen that both methods exhibit similar response to set point changes as expected but the first control strategy has a slight overshoot. To be able to see that the controller achieves good disturbance rejection, the measurements of substrate and DO are corrupted with step input disturbance (Amp=0.01) at $t=1285$ and the performance of both design methods are compared as shown in Fig. 7.

It can be clearly seen that the DAMBPC design method is able to track back to the set point quickly. The controller also rejects the disturbance in a reasonable time. The IAMBPC design method takes longer to reach the set point. This is also evident from large peak in the first output signals (Substrate) before it is slowly track back to the set point. The control signals are also given as shown in Fig. 8. Both control methods can handle constraint effectively, as shown in Fig. 8.

In summary, the disturbance rejection can be improved using DAMBPC design method. This can be seen in Fig. 7 and Fig. 8, whereby for a given input disturbance at $t=1285$, the DAMBPC reacts quickly and able to compensate the disturbance much faster compared to IAMBPC design method. Regarding the computational issue, it is shown by simulation that the DAMBPC outperform IAMBPC, both for SVD and QP methods. To be able to see the effect of computational load that results from directly calculating the

controller parameters, the summary of computation times (in sec) per sampling instant for different n and H_p for both methods is presented in [Table 1](#) and [Table 2](#), respectively. It can be clearly seen that the computation time required for SVD-based strategy is much lower (10 to 15 times) than the QP method. The SVD-based method shows an excellent performance, both for varying n and H_p . The tables also show the DAMBPC is faster than IAMBPC as expected.

5.1 Closed-loop Stability

The closed-loop stability of the proposed methods was extensively tested using simulation studies. The critical parameter to ensure the local stability when a local linear model is identified is the prediction horizon, H_p , and hence this must be selected carefully. Longer H_p will lead to better stability but this will also increase the computation load, and hence a trade-off should be made. Using the size of overshoot as an indication of stability, simulation results presented in Figs. 6 to 8 demonstrates that the DAMBPC has better stability robustness is than IAMBPC.

The overall closed-loop loop stability should also be analyzed for the nonlinear plant as stable linear local controllers are designed at each new operating condition. For the nonlinear process studied here, no global instability was observed as the system can in practice be stabilized by a set of PID controllers. Assuming the nonlinear plant is piecewise controllable and observable, the local MBPC controllers can then be designed to stabilize the nonlinear plant locally by choosing appropriate values for H_p . This does not, however, guarantee the global stability of the nonlinear plant. Johansson [23] shows that piecewise quadratic Lyapunov can be used for rigorous stability analysis of smooth nonlinear systems as well as quadratic stabilization of piecewise linear systems. The application of these techniques to the current problem is however out of scope of this paper.

6. Conclusions

The SVD- based data driven direct and indirect adaptive MBPC with input constraints were developed and tested in this paper. The derivation of DAMBPC control law only requires calculation of the subspace matrices L_u and L_w . There is no need for explicit calculation of system matrices A, B, C, D. The identification step and control design can be done simultaneously by making use of a single efficient calculation of QR decomposition of data block Hankel matrices. Secondly, the constrained case has been successfully incorporated into the algorithm using SVD-based strategy. The DAMBPC shows better performance with respect to input disturbance compared to IAMBPC. The direct approach does also give

better tracking properties as well as disturbance rejection when applied to a nonlinear process. On the other hand, the use of SVD-based strategy in the optimisation structure significantly reduces the online computational time associated with the solution of standard QP method. In this case, the DAMBPC outperform the IAMBPC and it can provide an attractive alternative. For fast dynamical systems such as aircraft or vehicle dynamics, it may still be necessary to develop a version of these algorithms that uses the recursive subspace model identification such as R4SID.

Acknowledgments: The first author is supported financially by Malaysian Government and Universiti Teknologi Malaysia. This support is gratefully acknowledged.

References

- [1] Leith D. J. and W. E. Leithead: 'Survey of gain-scheduling analysis and design', *Int. J. Control*, 2000, Vol. 73, No. 11, pp. 1001-1025.
- [2] Literature Survey, 'Adaptive Control and Signal Processing Survey (No. 17)', *Int. J. Adapt. Control Signal Process.* 2010, 24, pp. 337-342.
- [3] Francis B. A., J. C. Doyle, 'Linear control theory with an H-infinity optimality criterion', *SIAM J. Control and Opt.*, 25, 1987, pp. 815-844.
- [4] Van Helvoort J. J., 'Unfalsified Control: Data-Driven Control Design for Performance Improvement', Dissertation, Technische Universiteit Eindhoven, ISBN: 978-90-386-1167-9, 2007, ISBN 90-386-2975-32004.
- [5] Kostic, D, 'Data-driven robot motion control design', Dissertation, Technische Universiteit Eindhoven, ISBN 90-386-2975-3, 2004.
- [6] Aström K. J. and Björn Wittenmark, 1995: 'Adaptive control' (second ed., Addison Wesley).
- [7] Favoreel W., B. De Moor, P. Van Overschee, and M.Gevers.: 'Model-free subspace based LQG design'. Proceedings of the American Control Conference, San Diego, CA, 1998.
- [8] Favoreel W., B. De Moor and M.Gevers.: 'Subspace Predictive Control'. Proceedings of the 14th IFAC, Beijing, China, 1999.
- [9] Kadali R. B. Huang and A. Rossiter: 'A data driven subspace approach to predictive controller design', *Control Engineering Practice*, 2003, 7 (3), pp. 261-278.
- [10] Yang H., and Li. S.: 'Subspace-based adaptive predictive control of nonlinear systems', *International Journal of Innovative Computing, Information and Control*, 2005, 1 (4), pp.743-753.

- [11] Ruscio D.D.: 'Model based predictive control and identification: A linear state space model approach' Proceedings of the 36th Conference on Decision and Control, San Diego, CA, 1997b.
- [12] Wang X., B.Huang, and T. Chen.: 'Data driven predictive control for solid oxide fuel cells', Journal of process control, 2007 (17), pp. 103-114.
- [13] Piotrowski R., M.A. Brdys, K. Konarczak, K. Duzinkiewicz, W. Chotkowski.: 'Hierarchical dissolved oxygen control for activated sludge processes', Control Engineering Practice, 2007, 16, pp.114-131.
- [14] Wang, D. and J. Huang.: 'Adaptive neural network control for a class of uncertain nonlinear systems in pure-feedback form', Automatica, 2002, 38 (8), pp. 1365-1372.
- [15] Krishnan, K., and K.A.Kosanovich.: 'Batch reactor control using a multiple model-based controller design', Canadian Journal of Chemical Engineering, 1998, 76, pp. 806-815.
- [16] Narendra, K.S. and C.Xiang.: 'Adaptive control of discrete-time system using multiple models', IEEE Transactions on Automatic Control, 2000, 45 (9), pp. 1669-1686.
- [17] De Moor B.: 'Mathematical concepts and techniques for modelling of static and dynamic systems'. PhD thesis, Department of Electrical Engineering, Katholieke Univeriteit Leuven, Belgium, 1988.
- [18] Overschee P.V and De Moor B.: 'N4SID: Subspace identification for linear systems: theory, implementation, applications' (Kluwer Academic Publishers. Dordrecht, 1996)
- [19] Golub, Gene H. and Charles F. Van Loan: 'Matrix Computation'. (The Johns Hopkins University Press. Baltimore, Maryland, USA, 1996)
- [20] Rojas O.J., G.C. Goodwin, M.M. Serón and A. Feuer.: 'An SVD based strategy for receding horizon control of input constrained linear systems', International Journal of Robust and Nonlinear Control, 2004, 14, (13-14), pp. 1207-1226.
- [21] Overschee P.V. and De Moor B.: 'N4SID: Subspace algorithms for the identification of combined deterministic-stochastic systems', Automatica, 1994, 30 (1), pp. 75-93.
- [22] Takács I., G.G.Patry, D.Nolasco.: 'A dynamic model of the clarification thickening process', Water Research, 1991, 25, pp. 1263-1271.
- [23] Johansson, M., 'Piecewise Linear Control Systems: A Computational Approach', Springer-Verlag Berlin Heidelberg New York, ISBN 3-540-44124-7, 2003.

Table 1: CPU average times per sampling instant for different n

n	DAMBPC (SVD)	DAMBPC (QP)	IAMBPC (SVD)	IAMBPC (QP)
200	0.004	0.096	0.006	0.010
400	0.006	0.104	0.012	0.150
900	0.031	0.12	0.087	0.180

Table 2: CPU average times per sampling instant for different H_p

H_p	DAMBPC (SVD)	DAMBPC (QP)	IAMBPC (SVD)	IAMBPC (QP)
35	0.015	0.108	0.018	0.193
20	0.006	0.104	0.012	0.165
15	0.004	0.102	0.009	0.172
10	0.003	0.120	0.006	0.193