

Lawrence Berkeley National Laboratory

Lawrence Berkeley National Laboratory

Title

Database of prompt gamma rays from slow neutron capture for elemental analysis

Permalink

<https://escholarship.org/uc/item/1wj43711>

Authors

Firestone, R.B.

Choi, H.D.

Lindstrom, R.M.

et al.

Publication Date

2004-12-31

TECHNICAL REPORTS SERIES No.

***Database of Prompt Gamma Rays
from Slow Neutron
Capture for Elemental Analysis***

Final report of a coordinated research project

INTERNATIONAL ATOMIC ENERGY AGENCY

VIENNA, 2006

**Database of Prompt Gamma Rays from Slow Neutron
Capture for Elemental Analysis**

IAEA, Vienna, 2006

ISBN ..-.-.....-

H.D. Choi (Seoul National University, Republic of Korea),
R.B. Firestone (Lawrence Berkeley National Laboratory, USA),
R.M. Lindstrom (National Institute for Standards and Technology, USA),
G.L. Molnár (Institute of Isotope and Surface Chemistry, Hungary),
S.F. Mughabghab (Brookhaven National Laboratory, USA),
R. Paviotti-Corcuera (IAEA, Austria),
Zs. Révay (Institute of Isotope and Surface Chemistry, Hungary),
A. Trkov (IAEA, Austria),
C.M. Zhou (China Nuclear Data Centre, People's Republic of China).

Technical Assistance:

V. Zerkin (IAEA, Austria).

FOREWORD

The increasing importance of Prompt Gamma-ray Activation Analysis (PGAA) in a broad range of applications is evident, and has been emphasized at many meetings related to this topic (e.g., Technical Consultants' Meeting, Use of neutron beams for low and medium flux research reactors: radiography and materials characterization, IAEA Vienna, 4-7 May 1993, IAEA-TECDOC-837, 1995). Furthermore, an Advisory Group Meeting (AGM) for the Co-ordination of the Nuclear Structure and Decay Data Evaluators Network has stated that there is a need for a complete and consistent library of cold- and thermal-neutron capture gamma-ray and cross-section data (AGM held at Budapest, 14-18 October 1996, INDC(NDS)-363); this AGM also recommended the organization of an IAEA Co-ordinated Research Project (CRP) on the subject.

The nuclear data programmes of the IAEA arise as a consequence of the advisory reviews of the International Nuclear Data Committee (INDC). At a biennial meeting in 1997, the INDC strongly recommended that the IAEA support new measurements and update the database on Neutron-induced Prompt Gamma-ray Activation Analysis.

As a consequence of the various recommendations, a CRP on "*Development of a Database for Prompt Gamma-ray Neutron Activation Analysis (PGAA)*" was initiated in 1999. Prior to this project, several consultants had defined the scope, objectives and tasks of this CRP, as approved subsequently by the IAEA. Each CRP participant assumed responsibility for the execution of specific tasks. The results of their and other research work were discussed and approved by the participants in a series of research co-ordination meetings (see Summary reports: INDC(NDS)-411, 2000; INDC(NDS)-424, 2001; and INDC(NDS)-443, 2003).

PGAA is a non-destructive radioanalytical method capable of rapid or simultaneous "in-situ" multi-element analyses across the entire Periodic Table, from hydrogen to uranium. However, inaccurate and incomplete data have been a significant hindrance in the qualitative and quantitative analysis of complicated capture-gamma spectra by means of PGAA. Therefore, the main goal of the CRP was to improve the quality and quantity of the required data in order to make possible the reliable application of PGAA in fields such as materials science, chemistry, geology, mining, archaeology, environment, food analysis and medicine. This aim was achieved thanks to the dedicated work and effort of the participants. The CD-ROM included with this publication contains the database, the retrieval system, the three RCM reports, and other important electronic documents related to the project (see also Chapter 8).

The IAEA wishes to thank all CRP participants who contributed to the success of this project and the formulation of this publication. Special thanks are due to R.B. Firestone for his leading role in the evolution of this CRP and his comprehensive compilation, analysis and provision of the adopted database and V. Zerkin for the software developments associated with the retrieval system. An essential component of this data compilation is the extensive sets of new measurements of capture gamma-ray energies and intensities undertaken at the Institute of Isotope and Surface Chemistry, Budapest, Hungary. Thanks are also due to S.C. Frankle and M.A. Lone for their active involvement as consultants at some of the meetings. Finally, R. Paviotti-Corcuera (Division of Physical and Chemical Sciences) was the responsible officer for the CRP, this publication and the resulting database.

CONTENTS

1.	INTRODUCTION	1
2.	NOMENCLATURE, WESTCOTT g_w FACTORS AND NEUTRON SPECTRAL SHAPE DEPENDENT FORMALISM	6
2.1.	Definitions and nomenclature.....	6
2.1.1.	Prompt k_0 factor	6
2.1.2.	Elemental cross section.....	6
2.1.3.	Effective capture cross section	7
2.1.4.	Thermal and epithermal flux.....	7
2.1.5.	Westcott g-factor.....	8
2.2.	Generalized formalism	13
2.2.1.	Capture rate.....	13
2.2.2.	Non-1/v absorber, effective g-factor and Cd ratio	14
2.2.3.	Prompt capture- γ counting rate	16
2.2.4.	Experimental k_0 factor	17
2.3.	Concluding remarks.....	18
3.	CHARACTERISTICS OF PGAA FACILITIES.....	22
3.1.	SNU-KAERI PGAA facility and diffracted polychromatic neutron beam	22
3.2.	Characterization of prompt gamma neutron activation analysis at the Dalat research reactor	25
3.2.1.	Experimental configuration	25
3.2.2.	Characteristics of the system	27
3.3.	NIST PGAA	28
3.4.	Neutron capture gamma-ray facilities at the Budapest research reactor	30
3.4.1.	Beam characteristics	31
3.4.2.	PGAA instrumentation	31
3.4.3.	Detection efficiency and system non-linearity	33
3.4.4.	Data acquisition and analysis.....	34
3.5.	Prompt gamma-ray neutron activation analysis at Bhabha Atomic Research Centre (BARC)	34
3.5.1.	PGAA systems.....	34
3.5.2.	Sample irradiation and data acquisition.....	35
3.5.3.	Energy calibration and peak area analysis.....	35
3.5.4.	Efficiency calibration.....	36
3.5.5.	New beam facility at Dhruva reactor	37
3.6.	Summary of experimental facilities.....	38
3.7.	Experiments	40

4.	BENCHMARKS AND REFERENCE MATERIALS	47
4.1.	Characterization of the neutron beam.....	47
4.2.	Analysis of the unknown sample.....	49
4.3.	Cross-section measurements.....	50
5.	THERMAL NEUTRON CAPTURE CROSS SECTIONS AND NEUTRON SEPARATION ENERGIES	51
5.1.	Thermal cross-section evaluation methodology.....	51
5.2.	Adopted thermal neutron cross sections.....	52
5.3.	Experimental thermal neutron cross sections.....	52
5.4.	Neutron separation energies	53
6.	DATA SOURCES AND EVALUATION METHODOLOGY.....	70
6.1.	Prompt gamma-ray source databases	70
6.1.1.	Lone database	70
6.1.2.	ENSDF database.....	70
6.1.3.	Reedy and Frankle database	70
6.1.4.	Budapest database.....	70
6.2.	Evaluation databases.....	72
6.3.	Adopted gamma-ray energies.....	72
6.4.	Adopted gamma-ray cross sections	72
6.5.	Radioactive decay data	75
7.	ADOPTED DATABASE AND USER TABLES	78
7.1.	Numerical uncertainty presentation.....	78
7.2.	Isotopic data.....	78
7.3.	Radioactive decay data	78
7.4.	k_0 formulation	79
7.5.	PGAA data tables	79
7.5.1.	Prompt gamma rays	79
7.5.2.	Radioactive decay gamma rays.....	79
7.5.3.	Energy-ordered gamma-ray table	80
8.	PGAA-IAEA DATABASE: CD-ROM	178
8.1.	PGAA-IAEA Database Viewer	178
8.2.	PGAA data files.....	181
8.3.	Evaluated Gamma-ray Activation File (EGAF).....	182
8.4.	PGAA database evaluation.....	182
8.5.	Isotope Explorer 2.2, ENSDF Viewer	182

APPENDICES

APPENDIX I. BUDAPEST REACTOR GAMMA-RAY CROSS-SECTION DATA.....	186
APPENDIX II. ENSDF THERMAL NEUTRON CAPTURE GAMMA-RAY REFERENCES.....	201
DEFINITIONS.....	217
ACRONYMS FOR PROMPT-GAMMA ACTIVATION ANALYSIS.....	218
LIST OF PARTICIPANTS.....	219

1. INTRODUCTION

R.M. Lindstrom

Neutron-capture prompt-gamma activation analysis (PGAA) is especially valuable as a non-destructive nuclear method in the measurement of elements that do not form neutron capture products with delayed gamma-ray emissions. Furthermore, the elemental coverage of PGAA complements that of conventional (delayed) instrumental neutron activation analysis (INAA). The list of measurable elements emphasizes the low-Z and high-abundance elements in organic and geological materials, and the high cross-section elements: B, Cd, Sm and Gd. The analysis for hydrogen and boron is especially important because of the paucity of other reliable analytical techniques for trace levels of these elements. PGAA is extremely sensitive for the quantitative determination of B compared with destructive chemical techniques, particularly since boron is such an important element over a wide range of applications from meteorites to human tissue [1.1-1.4]. Together PGAA and INAA can measure all elements except oxygen in most common materials. Conveniently, in silicate rocks and similar oxidized materials, the completeness of the analysis can be tested by expressing the elements as oxides and comparing their sum with 100% [1.5]. Because nearly every neutron capture is an (n, γ) reaction, the yield of prompt gamma rays per neutron is greater than that of delayed gammas [1.6]. Unfortunately, PGAA has usually poorer sensitivity compared to INAA because the neutron flux is some five orders of magnitude lower in an external reactor beam than an irradiation position near the core.

Many review articles have been published on PGAA and its applications [1.7-1.12], and two extensive bibliographies have been compiled [1.13, 1.14]. The latter lists 522 references up to and including 1983. A dedicated book has also appeared [1.15], and an extensive handbook is in preparation [1.16]. Prompt gamma-ray analysis developed slowly after the first reports of gamma radiation from neutron capture by Lea [1.17] and the Fermi group [1.18]. The first published tabulation of gamma-ray energies and intensities [1.19] and plots of spectra [1.20] led to a number of applications during the era of NaI scintillation counters, from borehole logging [1.21] to planetary exploration [1.22]. Applications involving coincidence counting were first reported at the second international conference on Modern Trends in Activation Analysis (MTAA-2) [1.23].

The first measurements by reactor-based PGAA were published in 1966 [1.6, 1.24, 1.25]. Chopped (pulsed) beams were used in one of the first applications to separate prompt gamma rays from delayed activation products [1.26]. Neutron guides were also first reported in the same year [1.27], and soon afterwards pioneering PGAA work at Saclay with thermal guides and Ge(Li) detectors was reported at MTAA-3 [1.28, 1.29].

A major breakthrough in the late 1960s was the introduction of germanium semiconductor gamma-ray detectors, with energy resolutions twenty or more times better than the best NaI scintillators. This development was a considerable aid in the interpretation of complex spectra resulting from neutron capture [1.30]. Diffraction spectrometers used by the nuclear physics community have still better resolution [1.31], but their efficiency is far too low for practical analysis of materials. Application of Ge detectors to INAA [1.32] and PGAA [1.33] was rapid, and their superior resolution gave improved detection limits [1.34] which led to Ge replacing NaI wherever liquid nitrogen was available to cool the detector.

Early in the application of Ge detectors, a group at the Massachusetts Institute of Technology (MIT) measured the capture-gamma spectra of every element systematically [1.35, 1.36].

Compilations of these data were published in the open literature, with analytical sensitivities and spectral contrasts tabulated [1.37, 1.38]. At this time the combination of high-power research reactors and large, high resolution gamma-ray detectors was pursued in parallel at several reactor centres in the USA, Japan and Canada [1.5, 1.39-1.42]. Each of these laboratories compiled tables of analytical gamma rays and their interferences. For example, at the University of Maryland 28 gamma rays from 20 elements were found to be potential interferences with the sulphur line at 841.1 keV (from the $^{32}\text{S}(n, \gamma)^{33}\text{S}$ reaction) [1.43]. An evaluation directed at the spectrometry of planetary surfaces was published at the same time [1.22].

A major advance was the comprehensive Chalk River compilation of more than 10,000 capture gamma rays of the elements [1.44], with their energies, abundances, and cross sections drawn chiefly from the MIT measurements. The completeness of the data and their convenient format made the "Lone table" indispensable at the desk of every PGAA researcher for twenty years, despite some inadequacies inherent in these early measurements. A substantial computer-readable subset of these data was made available on diskette with an IAEA Technical Report [1.45], and the complete table has been circulated informally in spreadsheet form among many researchers.

Very recently, a carefully evaluated table of capture gamma rays from the elements hydrogen through zinc has been published [1.46]. The present work incorporates this evaluation, and adds recently measured energies and intensities of capture gamma rays of the elements from the PGAA facility at the Budapest Research Reactor, and data from other CRP participants and elsewhere. As discussed in detail in chapter 6, these data are combined and compared with nuclear levels and other information from the Evaluated Nuclear Structure Data File (ENSDF) to produce a comprehensive, self-consistent set of capture gamma rays.

In the past decade the application of PGAA has increased because of the availability of high-flux thermal and cold beams from neutron guides [1.47]. Guided beams can be entirely free of fast neutrons and tramp gamma rays, and therefore signal/background ratios can be much improved. Thermal guide studies at Kyoto have also shown that spectral quality is perhaps as important as flux in performing high-sensitivity analyses [1.4]. Fifteen years after the pioneering work at Grenoble using a flux that is still the highest ever used for PGAA [1.48], there has been a flowering of applications at several neutron sources [1.49-1.55].

Prompt-gamma neutron activation analysis has become a well-established analytical method with applications in many areas. The new data compilation presented here should encourage the further use of PGAA in the future.

REFERENCES

- [1.1] FURUKAWA, Y., KOYAMA, M., YUKI, M., Determination of Boron Content in Several Mediums by Prompt Gamma Ray Analysis, *Radioisotopes* **16** (1967) 7-11.
- [1.2] GLADNEY, E. S., JURNEY, E. T., CURTIS, D. B., Nondestructive Determination of Boron and Cadmium in Environmental Materials by Thermal Neutron-prompt Gamma-ray Spectrometry, *Anal. Chem.* **48** (1976) 2139-2142.
- [1.3] CURTIS, D. B., GLADNEY, E. S., JURNEY, E. T., A Revision of the Meteorite Based Cosmic Abundance of Boron, *Geochim. Cosmochim. Acta* **44** (1980) 1945-1953.

- [1.4] KOBAYASHI, T., KANDA, K., Microanalysis System of PPM-order ^{10}B Concentrations in Tissue for Neutron Capture Therapy by Prompt Gamma-ray Spectrometry, *Nucl. Instrum. Meth.* **204** (1983) 525-531.
- [1.5] FAILEY, M. P., ANDERSON, D. L., ZOLLER, W. H., GORDON, G. E., LINDSTROM, R. M., Neutron-capture Prompt Gamma-ray Activation Analysis for Multi-element Determination in Complex Samples, *Anal. Chem.* **51** (1979) 2209-2221.
- [1.6] ISENHOUR, T. L., MORRISON, G. H., Modulation Technique for Neutron Capture Gamma-ray Measurements in Activation Analysis, *Anal. Chem.* **38** (1966) 162-167.
- [1.7] GREENWOOD, R. C., "Practical Applications of Neutron Capture Gamma Rays", *Proc. Third Int. Symp. Neutron-capture Gamma-ray Spectroscopy and Related Topics*, (Chrien, R. E., Kane, W. R., eds.), Plenum, New York (1979) 441-460.
- [1.8] ANDERSON, D. L., ZOLLER, W. H., GORDON, G. E., WALTERS, W. B., LINDSTROM, R. M., "Neutron-capture Prompt Gamma-ray Spectroscopy as a Quantitative Analytical Method", *Neutron-capture Gamma-ray Spectroscopy and Related Topics*, *Inst. Phys. Ser.* **62**, (von Egidy, T., Gonnenwein, F., Maier, B., eds.), Institute of Physics, London (1982) 655-668.
- [1.9] LINDSTROM, R. M., PAUL, R. L., WALTERS, W. B., MOLNÁR, G., "Analytical Applications of Cold Neutron Capture and Opportunities for Nuclear Physics", *Capture Gamma-ray Spectroscopy and Related Topics*, (Kern, J., ed.), World Scientific, Singapore (1994) 955-961.
- [1.10] LINDSTROM, R. M., ANDERSON, D. L., PAUL, R. L., "Analytical Applications of Neutron Capture Gamma Rays", *Proc. 9th Int. Symp. Capture Gamma-ray Spectroscopy and Related Topics*, (Molnár, G. L., Belgya, T., Révay, Z., eds.), Springer, Budapest (1997) 693-704.
- [1.11] SHAW, D. M., Prompt Gamma Neutron Activation Analysis, *J. Neutron Res.* **7** (1999) 181-194.
- [1.12] PAUL, R. L., LINDSTROM, R. M., Prompt Gamma-ray Activation Analysis: Fundamentals and Applications, *J. Radioanal. Nucl. Chem.* **243** (2000) 181-189.
- [1.13] GLADNEY, E. S., A Literature Survey of Chemical Analysis by Thermal Neutron-induced Capture Gamma-ray Spectroscopy, Los Alamos Scientific Laboratory Report LA-8028-MS, 1979.
- [1.14] GLASCOCK, M. D., A Literature Survey of Elemental Analysis by Neutron-induced Prompt Gamma-ray Spectroscopy and Related Topics, University of Missouri Report, Columbia, 1984.
- [1.15] ALFASSI, Z. B., CHUNG, C., eds., Prompt Gamma Neutron Activation Analysis, CRC Press, Boca Raton, 1995.
- [1.16] MOLNÁR, G. L., ed., Handbook of Prompt Gamma Activation Analysis, Kluwer, Dordrecht, 2004.
- [1.17] LEA, D. E., Combination of Proton and Neutron, *Nature* **133** (1934) 24.
- [1.18] AMALDI, E., D'AGOSTINO, O., FERMI, E., PONTECORVO, B., RASETTI, F., SEGRÈ, E., Radioattività Provocata da Bombardamento di Neutroni - VII, *Ricerca Scientifica* **2** (1934) 467-470.
- [1.19] GROSHEV, L. V., DEMIDOV, A. M., LUTSENKO, V. N., PELEKHOV, V. I., Atlas of the Spectra of Gamma Rays from the Radiative Capture of Thermal Neutrons. Pergamon, London (1961).
- [1.20] GREENWOOD, R. C., REED, J. H., Prompt Gamma Rays from Radiative Capture of Thermal Neutrons, IIT Research Institute Report IITRI-1193-53, 1965.
- [1.21] CLAYTON, C. G., SCHWEITZER, J. S., A Review of Aspects of Nuclear Geophysics, *Nucl. Geophysics* **7** (1993) 143-171.
- [1.22] REEDY, R. C., "Planetary Gamma-ray Spectroscopy", *Proc. 9th Lunar Planet. Sci. Conf.* (1978), Pergamon, New York, 2961-2984.

- [1.23] LUSSIE, W. G., BROWNLEE, J. L., Jr., The Measurement and Utilization of Neutron-capture Gamma Radiation, Proc. Modern Trends in Activation Analysis, (Guinn, J. P., ed.), Texas A&M, College Station, (1965), 194-199.
- [1.24] KITAO, K., HATTORI, M., NAGAHARA, T., HAM, C., "Elemental Analysis Using Capture Gamma-rays" (in Japanese), Proc. 7th Conf. Radioisotopes, Japanese Atom. Indust. Forum (1966) 249-251.
- [1.25] KOYAMA, M., KOYAMA, Y., MINATO, Y., YUKI, M., "Thermal Neutron Capture Gamma-ray Spectrometry" (in Japanese), Proc. 7th Conf. Radioisotopes, Japanese Atom. Indust. Forum (1966) 246-248.
- [1.26] ISENHOUR, T. L., MORRISON, G. H., Determination of Boron by Thermal Neutron Activation Analysis Using a Modulation Technique, Anal. Chem. **38** (1966) 167- 169.
- [1.27] MAIER-LEIBNITZ, H., Grundlagen fuer die Beurteilung von Intensitaets- und Genauigkeitsfragen bei Neutronenstrommessungen, Nukleonik 8 (1966) 61-67
- [1.28] COMAR, D., CROUZEL, C., CHASTELAND, M., RIVIERE, R., KELLERSHOHN, C., "The Use of Neutron Capture Gamma Radiations for the Analysis of Biological Samples", Modern Trends in Activation Analysis, NBS Special Pub. 312, (DeVoe, J. R., ed.), National Bureau of Standards, Washington DC (1969) 114-127.
- [1.29] COMAR, D., CROUZEL, C., CHASTELAND, M., RIVIERE, R., KELLERSHOHN, C., The Use of Neutron-capture Gamma Radiation for the Analysis of Biological Samples, Nucl. Appl. **6** (1969) 344-351.
- [1.30] ORPHAN, V. J., RASMUSSEN, N. C., A Ge(Li) Spectrometer for Studying Neutron Capture Gamma Rays, Nucl. Instrum. Meth. **48** (1967) 282-295.
- [1.31] KOCH, H. R., BÖRNER, H. G., PINSTON, J. A., DAVIDSON, W. F., FAUDOU, J., ROUSSILLE, R., SCHULT, O. W. B., The Curved Crystal Gamma Ray Spectrometers "GAMS 1, GAMS 2, GAMS 3" for High Resolution (n, γ) Measurements at the High Flux Reactor in Grenoble, Nucl. Instrum. Meth. **175** (1980) 401-423.
- [1.32] GORDON, G. E., RANDLE, K., GOLES, G. G., CORLISS, J. B., BEESON, M. H., OXLEY, S. S., Instrumental Activation of Standard Rocks with High-resolution γ -ray Detectors, Geochim. Cosmochim. Acta **32** (1968) 369-396.
- [1.33] LOMBARD, S. M., ISENHOUR, T. L., Neutron Capture Gamma-ray Activation Analysis Using Lithium Drifted Germanium Semiconductor Detectors, Anal. Chem. **40** (1968) 1990-1994.
- [1.34] ROBERTSON, R., SPYROU, N. M., KENNETT, T. J., Low-level Gamma-ray Spectrometry: NaI(Tl) vs. Ge(Li), Anal. Chem. **47** (1975) 65-70.
- [1.35] RASMUSSEN, N. C., HUKAI, Y., INOUE, T., ORPHAN, V. J., Thermal Neutron Capture Gamma-ray Spectra of the Elements, Massachusetts Institute of Technology Report AFCRL-69-0071, 1969.
- [1.36] ORPHAN, V. J., RASMUSSEN, N. C., HARPER, T. L., Line and Continuum Gamma-ray Yields from Thermal-neutron Capture in 75 Elements, Gulf General Atomic Report DASA 2570 (GA 10248), 1970.
- [1.37] DUFFEY, D., EL-KADY, A., SENFTLE, F. E., Analytical Sensitivities and Energies of Thermal Neutron Capture Gamma Rays, Nucl. Instrum. Meth. **80** (1970) 149-171.
- [1.38] SENFTLE, F. E., MOORE, H. D., LEEP, D. B., EL-KADY, A. A., DUFFEY, D., Analytical Sensitivities and Energies of Thermal Neutron Capture Gamma Rays II, Nucl. Instrum. Meth. **93** (1971) 425-459.
- [1.39] GLADNEY, E. S., CURTIS, D. B., JURNEY, E. T., Multielement Analysis of Major and Minor Elements by Thermal Neutron Induced Capture Gamma-ray Spectrometry, J. Radioanal. Chem. **46** (1978) 299-308.
- [1.40] TOJO, T., YONEZAWA, C., KOURA, S., ARAI, S., KOMORI, T., A Neutron Capture Gamma-ray Facility, Japan Atomic Energy Research Institute Report JAERI-M 8791, 1980.

- [1.41] HANNA, A. G., BRUGGER, R. M., GLASCOCK, M. D., The Prompt Gamma Neutron Activation Analysis Facility at MURR, *Nucl. Instrum. Meth.* **188** (1981) 619-627.
- [1.42] HIGGINS, M. D., TRUSCOTT, M. G., SHAW, D. M., BERGERON, M., BUFFET, G. H., COPLEY, J. R. D., PRESTWICH, W. V., "Prompt-gamma Neutron Activation Analysis at McMaster Nuclear Reactor", *Use and Development of Low and Medium Flux Research Reactors*, (Harling, O. K., Clark, L., von der Hardt, P., eds.), Thiemig, Munich (1984) 690-697.
- [1.43] KITTO, M. E., Receptor Modeling of Atmospheric Particles and Acidic Gases, PhD Thesis, University of Maryland, College Park, 1987.
- [1.44] LONE, M. A., LEAVITT, R. A., HARRISON, D. A., Prompt Gamma Rays from Thermal-neutron Capture, *At. Data Nucl. Data Tables* 26 (1981) 511-559.
- [1.45] IAEA Handbook on Nuclear Data for Borehole Logging and Mineral Analysis (TR-357), International Atomic Energy Agency, Vienna, Austria (1993).
- [1.46] REEDY, R. C., FRANKLE, S. C., Prompt Gamma Rays from Radiative Capture of Thermal Neutrons by Elements from Hydrogen through Zinc, *Atom. Nucl. Data Tables* 80 (2002), 1-34.
- [1.47] LINDSTROM, R. M., YONEZAWA, C., "Prompt-Gamma Activation Analysis With Guided Neutron Beams," *Prompt Gamma Neutron Activation Analysis*, (Alfassi, Z. B., Chung, C., Ed.) CRC Press, Boca Raton (1995), 93-100.
- [1.48] HENKELMANN, R., BORN, H. J., Analytical Use of Neutron-capture Gamma-rays, *J. Radioanal. Chem.* **16** (1973) 473-481.
- [1.49] KERR, S. A., OLIVER, R. A., VITTOZ, P., VIVIER, G., HOYLER, F., MACMAHON, T. D., WARD, N. I., Elemental Concentrations in Geochemical Reference Samples by Neutron Capture Prompt Gamma-ray Spectroscopy, *J. Radioanal. Nucl. Chem.* **113** (1987) 249-258.
- [1.50] LINDSTROM, R. M., ZEISLER, R., ROSSBACH, M., Activation Analysis Opportunities Using Cold Neutron Beams, *J. Radioanal. Nucl. Chem.* **112** (1987) 321-330.
- [1.51] YONEZAWA, C., HOSHI, M., ITO, Y., TACHIKAWA, E., "Construction of Reactor Neutron Induced Prompt Gamma-ray Analyzing System at the Neutron Beam Guide of JRR-3M", *Proc. Third Asian Symp. Research Reactors*, Japan Atomic Energy Research Institute Report JAERI-M 92-028 (1992) 583.
- [1.52] LINDSTROM, R. M., ZEISLER, R., VINCENT, D. H., GREENBERG, R. R., STONE, C. A., ANDERSON, D. L., CLARK, D. D., MACKEY, E. A., Neutron Capture Prompt Gamma-ray Activation Analysis at the NIST Cold Neutron Research Facility, *J. Radioanal. Nucl. Chem.* **167** (1993) 121-126.
- [1.53] MOLNÁR, G., RÉVAY, Z., VERES, Á., SIMONITS, A., RAUSCH, H., Cold Neutron Facility for Prompt Gamma Neutron Activation Analysis, *J. Radioanal. Nucl. Chem.* **167** (1993) 133-137.
- [1.54] ÜNLÜ, K., RÍOS-MARTÍNEZ, C., WEHRING, B. W., Prompt Gamma Activation Analysis with the Texas Cold Neutron Source, *J. Radioanal. Nucl. Chem.* **193** (1995) 145-154.
- [1.55] CRITTIN, M., KERN, J., SCHENKER, J.-L., The New Prompt Gamma-ray Activation Facility at the Paul Scherrer Institute, Switzerland, *Nucl. Instrum. Meth. Phys. Rev.* **A449** (2000) 221-236.

2. NOMENCLATURE, WESTCOTT k_0 FACTORS AND NEUTRON SPECTRAL SHAPE DEPENDENT FORMALISM

H.D. Choi, A. Trkov

A wide range of neutron source facilities are used for the implementation of PGAA that can be divided into two groups: one group uses thermal or cold neutrons from nuclear reactors, while the other group utilizes smaller mobile systems that involve moderated neutrons from isotopic sources, neutron generators or accelerator driven systems. Reactor-based systems use an internal target [2.1, 2.2] or external direct beam [2.3] to take advantage of the large neutron flux. At present, the common trend is towards building facilities around guided thermal beams [2.4-2.6] or guided cold beams [2.4, 2.7-2.9] in order to prepare a very clean beam free from epithermal neutrons and background gamma rays. Another possibility is to use external filtered beams [2.10] or diffracted beams [2.11, 2.12], which are also characterized by low background.

Among the many differences between the facilities, the neutron energy spectrum and the epithermal neutron fraction have an important influence on the measured capture rate, particularly for large samples and non- $1/v$ absorber nuclides. Even for some nuclides that are commonly considered good $1/v$ absorbers, slight deviations from $1/v$ capture may exist. Inhomogeneous flux profile also affects the measurement. Precise measurements and standardization can only be achieved by investigating the impact of these effects before k_0 values from different facilities can be compared for consistency. Hence in the present chapter, definition of nomenclature and a general formalism are reviewed in the context of k_0 standardization to accommodate the various forms of neutron spectra.

2.1. Definitions and nomenclature

2.1.1. Prompt k_0 factor

Co-irradiating in a neutron field an analyte (x) and a comparator (c) element contained in the sample results in the composite nuclear constant (k_0 factor) defined as [2.13-2.15]:

$$k_0 = \frac{P_x(E_{\gamma,x}) \cdot \sigma_{0,x} \cdot \theta_x / M_x}{P_c(E_{\gamma,c}) \cdot \sigma_{0,c} \cdot \theta_c / M_c}, \quad (1)$$

where the subscripts x and c refer to the analyte and comparator element respectively, θ is the isotopic abundance, M the atomic weight of the element, $P(E_\gamma)$ the absolute γ emission probability (γ s emitted per capture) of the prompt gamma ray of energy E_γ and σ_0 is the 2200 m s⁻¹ neutron capture cross section. It is implicitly assumed that the specific isotope that captures a neutron will decay promptly by emitting a γ ray of energy E_γ .

The evolution of k_0 -methodology has resulted in different definitions (e.g., by using either effective capture cross section or effective thermal capture cross section instead of 2200 m s⁻¹ cross section [2.16]). Use of σ_0 is emphasized in the present definition in order to keep the k_0 factor as an absolute constant measurable in a facility-independent manner.

2.1.2. Elemental cross section

Neutron speed-dependent capture cross sections $\sigma_\gamma(v)$ and 2200 m s⁻¹ values (σ_0) are defined

for a nucleus of an isotope. The partial capture cross section for the nucleus ($\sigma_\gamma(E_\gamma)$), is defined by the product $P(E_\gamma)\sigma_0$; the differential form $P(E_\gamma)\sigma_\gamma(v)$ is also used in physics studies. An elemental cross section is defined for practical convenience in terms of a sample with isotopic natural abundance, and this parameter should be distinguished from the nuclear capture cross section and partial nuclear capture cross section. A partial elemental capture cross section for the element Z is defined by:

$$\sigma_\gamma^Z(E_\gamma) = \theta P(E_\gamma) \sigma_0, \quad (2)$$

where the notation is the same as listed previously. This term is the cross section per elemental atom to produce a particular gamma-ray of energy E_γ from irradiation with thermal neutrons. Different names are frequently used, such as “gamma-ray production cross section” [2.17] or “partial (elemental) cross section” [2.18], both implying the partial elemental capture cross section.

2.1.3. *Effective capture cross section*

The effective capture cross section is defined as the averaged cross section over the neutron spectrum by the equation:

$$\hat{\sigma} = \frac{1}{v_0} \cdot \frac{\int_0^\infty n(v)\sigma_\gamma(v)v dv}{\int_0^\infty n(v)dv} = \frac{1}{n_t v_0} \int_0^\infty n(v)\sigma_\gamma(v)v dv = \frac{1}{v_0} \int_0^\infty \rho(v)\sigma_\gamma(v)v dv \quad (3)$$

where v is the neutron speed and v_0 equals 2200 m s^{-1} , $n(v)dv$ is the number density of neutrons with speed between v and $v+dv$, $\sigma_\gamma(v)$ is the neutron speed-dependent capture cross section of the nuclide under consideration, n_t is the total neutron density including both thermal and epithermal neutrons, and $\rho(v)$ is the neutron speed distribution function after normalization. These are :

$$n_t = \int_0^\infty n(v)dv \quad \text{and} \quad \int_0^\infty \rho(v)dv = 1 \quad (4)$$

in which the Westcott convention is adopted [2.19]. However, when the Stoughton and Halperin convention is used [2.20], thermal neutron density appears in the denominator of Equation (3). A different convention is used for the effective cross section $\langle\sigma\rangle$ in Chapter 4 to characterize the neutron beam:

$$\langle\sigma\rangle = \frac{\int_0^\infty n(v)\sigma_\gamma(v)v dv}{\int_0^\infty n(v)v dv} \quad (5)$$

where the integrated total flux is used in the denominator. The average cross section is related to the effective cross section in Equation (3) by $\langle\sigma\rangle = \hat{\sigma} v_0 / \langle v \rangle$ where $\langle v \rangle$ is the average speed calculated using neutron density $n(v)$ as the weighting function. Equations (3) – (5) are applicable to any arbitrary neutron spectrum.

2.1.4. *Thermal and epithermal flux*

As a consequence of the importance of thermal neutrons in capture reaction and the very large

differences in the spectral shape and the fraction of epithermal neutrons in different irradiation facilities, the neutron density per unit speed interval is split into thermal and epithermal components:

$$n(v) = n_{th}(v) + n_{ep}(v) \quad (6)$$

Reactor thermal neutron spectrum is well represented by the Maxwellian speed distribution, and the integrated thermal neutron density is given by:

$$n_{th} = \int_0^{\infty} n_{th}(v) dv = n_{th} \int_0^{\infty} \rho_M(v) dv, \quad (7)$$

where $\rho_M(v)$ is the normalized Maxwellian function. Different definitions for the thermal flux can be found in the literature [2.20]. The widely used definition in activation analysis is the “conventional” thermal flux given by:

$$\phi_{th} = n_{th} v_0 \quad (8)$$

while the “true (integrated)” or “mean” thermal flux is the most convenient in reactor physics calculations and is defined as:

$$F_{th} = \int_0^{\infty} n_{th}(v) v dv = n_{th} \int_0^{\infty} \rho_M(v) v dv = n_{th} \bar{v} \quad (9)$$

where \bar{v} is the average speed of the Maxwellian distribution. Hence, the relationship between the two fluxes [$F_{th}/\phi_{th} = \bar{v}/v_0 = (4T/\pi T_0)^{1/2}$] holds true for the Maxwellian thermal spectrum (where T is the Maxwellian temperature, $T_0 = 293.6K$). The thermal capture rates for $1/v$ absorbers are the same for either flux representation, so long as the correct cross section is used; for example, $R_{th} = n_{th} v_0 \sigma_0 = n_{th} \bar{v} \bar{\sigma}$ where $\bar{\sigma}$ is the capture cross section at neutron speed \bar{v} . The neutron flux ϕ_{ep} is more convenient in the case of epithermal neutrons, and represents the product of neutron speed and density ($\phi_{ep} = v n_{ep}$). This approach describes the neutron flux spectrum in terms of energy, and is based on theoretical considerations that ideally the distribution follows $1/E$ shape. Since the flux integral in neutron speed and in energy domain must be the same, we obtain the relationship between the epithermal neutron density and the flux:

$$n_{ep}(v) v dv = \phi_{ep}(E) dE = \phi_{ep} dE/E \quad (10)$$

Slight deviations from $1/E$ can be described by $1/E^{1+\alpha}$ where α is the epithermal shape parameter used widely in instrumental neutron activation analysis (INAA) [2.13, 2.21]. However, most PGAA facilities prepare a clean thermal or cold beam by means of neutron guide tubes or short wavelength filters. These beams are free from epithermal neutrons as indicated by the cadmium ratio, being typically larger than 10^4 [2.22]. Hence, the need to consider epithermal neutrons is obviated in facilities capable of producing a clean thermal neutron beam.

2.1.5. Westcott g-factor

The effective cross section in Equation (3) is equal to the 2200 m s^{-1} cross section σ_0 for a perfect $1/v$ absorber or even a realistic $1/v$ absorber nuclide irradiated in neutron fields with negligible epithermal neutron fraction in the resonance region of the nuclide. When the nuclide is a non- $1/v$ absorber (^{113}Cd , ^{124}Xe , ^{149}Sm , most Eu isotopes, $^{155, 157}\text{Gd}$, $^{175, 176}\text{Lu}$,

¹⁸⁰Ta etc.) or the neutron spectrum contains a significant epithermal component, the effective cross section is no longer equal to σ_0 . Westcott approached this problem for the case of a Maxwellian thermal spectrum and a 1/E epithermal spectrum [2.19]. Adopting the Westcott convention, the effective cross section is given by:

$$\hat{\sigma} = \sigma_0(g_w + rs) \quad (11)$$

where g_w is the Westcott g-factor, r is an index for epithermal fraction in the neutron density, and s is a parameter related to the reduced resonance integral. Parameter r for 1/E epithermal neutrons can be obtained by measuring the Cd ratio with a thin 1/v detector or an activation foil [2.19]. Since the Maxwellian shape depends on the temperature, both g_w and s are dependent on the Maxwellian temperature. Hence, the Westcott g-factor is given by the ratio of the effective cross section for the pure Maxwellian spectrum ($\hat{\sigma}_M$) to the 2200 m s⁻¹ cross section:

$$g_w(T) = \frac{\hat{\sigma}_M(T)}{\sigma_0} = \frac{1}{\sigma_0 v_0} \int_0^\infty \rho_M(v, T) \sigma_\gamma(v) v dv = \frac{1}{\sigma_0 v_0} \int_0^\infty \frac{4}{\sqrt{\pi}} \left(\frac{v}{v_T} \right)^3 e^{-(v/v_T)^2} \sigma_\gamma(v) dv \quad (12)$$

where v_T is the most probable speed of the Maxwellian function, and is related to the temperature (T) by $mv_T^2/2 = kT$ or $v_T = v_0(T/T_0)^{1/2}$.

The latest published values of the Westcott g-factors are given by Holden [2.23] for nuclides with Westcott g-factors that deviate significantly from unity and for temperatures between 0 and 400°C. A series of new g-factor calculations has been carried out for this CRP using the capture cross sections from the EAF-99 library [2.24] over an extended temperature range of 20 to 600K. Almost all isotopes up to ²⁵⁷Fm have been considered in these calculations. Two sets of calculated data have been generated using different codes:

- ENDF utility code INTER was used to generate the Westcott g-factors by direct integration.
- A new code GRUPINT was developed to deal with the general neutron spectrum (e.g., a sum of Maxwellian functions of different temperatures, which is typically adopted to describe the spectrum of guided neutron beam). Instead of using direct integration, GRUPINT reads in fine-group cross sections in 685-group structure, and calculates the Westcott g-factors by group condensation.

GRUPINT was validated by comparing the results from both codes for a pure Maxwellian spectrum. The g-factors agree within considerably less than 1% for all isotopes considered, although a few exceptional cases are noted:

- ¹⁵³Tb exhibits an anomalous jump in the tabulated cross sections at the thermal energy, although the overall trend is 1/v. The INTER result reflects the anomalous behaviour; and the final GRUPINT g-value is produced assuming a smooth 1/v shape.
- ¹⁸⁷Re(n, γ) has different shapes for the cross sections of the final activation products ¹⁸⁸Re (ground state) and ^{188m}Re, in which only the excitation cross section for the ground state exhibits a non-1/v behaviour. Even though the reasons for such cross sectional behaviour need closer investigation, this example indicates that explicit consideration of cross sections for the final production state could be important, depending on the nature of activation detection.

The Westcott g-factors are listed in Tables 2.1-2.3 for those stable isotopes in which the Westcott g-factor deviates from unity by more than 1% at some temperature in the specified range.

Table 2.1 Westcott g-factors ($A \leq 143$).

T(K)	E(eV)	³⁰ Si	³⁶ S	³⁶ Ar	³⁸ Ar	⁸³ Kr	⁸⁷ Sr	¹⁰³ Rh	¹⁰⁵ Pd	¹⁰⁹ Ag	¹¹¹ Cd
20	0.0017	1.000	0.799	1.135	1.266	1.011	0.990	0.964	1.008	0.991	1.009
40	0.0034	1.000	0.842	1.104	1.242	1.010	0.991	0.968	1.008	0.992	1.008
60	0.0052	1.000	0.871	1.078	1.197	1.009	0.992	0.972	1.007	0.993	1.008
80	0.0069	1.000	0.894	1.060	1.161	1.008	0.994	0.976	1.006	0.994	1.006
100	0.0086	1.000	0.912	1.049	1.133	1.006	0.995	0.981	1.005	0.995	1.005
120	0.0103	1.001	0.928	1.040	1.111	1.005	0.996	0.985	1.004	0.996	1.004
140	0.0121	1.001	0.942	1.035	1.095	1.004	0.997	0.989	1.003	0.997	1.003
160	0.0138	1.003	0.954	1.030	1.082	1.003	0.998	0.993	1.002	0.998	1.002
180	0.0155	1.003	0.965	1.026	1.072	1.001	0.999	0.998	1.001	0.999	1.001
200	0.0172	1.003	0.975	1.023	1.064	1.000	1.000	1.002	0.999	1.000	0.999
220	0.0190	1.004	0.984	1.021	1.057	0.999	1.001	1.007	0.999	1.001	0.999
240	0.0207	1.005	0.993	1.020	1.051	0.998	1.003	1.011	0.998	1.003	0.998
260	0.0224	1.006	1.001	1.018	1.046	0.996	1.004	1.015	0.997	1.003	0.996
280	0.0241	1.007	1.009	1.016	1.043	0.996	1.005	1.020	0.996	1.005	0.996
293	0.0253	1.007	1.014	1.016	1.040	0.995	1.006	1.023	0.995	1.005	0.995
300	0.0258	1.007	1.017	1.016	1.039	0.994	1.006	1.025	0.995	1.005	0.994
320	0.0276	1.008	1.023	1.015	1.036	0.993	1.007	1.029	0.994	1.006	0.993
340	0.0293	1.008	1.030	1.014	1.033	0.992	1.008	1.034	0.993	1.007	0.992
360	0.0310	1.009	1.036	1.013	1.031	0.991	1.010	1.039	0.992	1.008	0.991
380	0.0327	1.009	1.042	1.012	1.029	0.989	1.011	1.044	0.991	1.009	0.990
400	0.0345	1.010	1.047	1.012	1.027	0.988	1.012	1.048	0.990	1.010	0.989
420	0.0362	1.010	1.053	1.011	1.025	0.987	1.013	1.053	0.989	1.011	0.988
440	0.0379	1.011	1.058	1.011	1.024	0.986	1.014	1.059	0.988	1.012	0.987
460	0.0396	1.012	1.063	1.010	1.023	0.985	1.015	1.064	0.987	1.013	0.986
480	0.0414	1.012	1.068	1.010	1.021	0.984	1.017	1.069	0.986	1.015	0.985
500	0.0431	1.013	1.072	1.010	1.020	0.982	1.018	1.074	0.985	1.015	0.984
520	0.0448	1.013	1.077	1.010	1.019	0.981	1.019	1.079	0.984	1.017	0.983
540	0.0465	1.014	1.081	1.010	1.018	0.980	1.020	1.085	0.983	1.018	0.982
560	0.0482	1.014	1.086	1.009	1.018	0.979	1.022	1.090	0.983	1.019	0.980
580	0.0500	1.015	1.090	1.009	1.017	0.978	1.023	1.096	0.982	1.020	0.979
600	0.0517	1.015	1.094	1.009	1.016	0.976	1.024	1.101	0.981	1.021	0.979

T(K)	E(eV)	¹¹³ Cd	¹¹³ In	¹¹⁵ In	¹²¹ Sb	¹²³ Te	¹²⁴ Xe	¹³³ Cs	¹³² Ba	¹³⁸ Ce	¹⁴³ Nd
20	0.0017	0.780	0.979	0.969	0.994	0.980	0.994	0.995	1.000	0.936	1.007
40	0.0034	0.802	0.982	0.973	0.995	0.983	0.994	0.996	1.000	0.952	1.006
60	0.0052	0.826	0.984	0.976	0.995	0.985	0.995	0.997	1.000	0.962	1.005
80	0.0069	0.852	0.986	0.979	0.996	0.987	0.996	0.997	0.999	0.969	1.005
100	0.0086	0.880	0.988	0.984	0.997	0.989	0.997	0.998	0.998	0.974	1.004
120	0.0103	0.911	0.991	0.987	0.997	0.992	0.997	0.998	0.997	0.978	1.003
140	0.0121	0.945	0.993	0.990	0.998	0.994	0.999	0.999	0.995	0.981	1.002
160	0.0138	0.982	0.996	0.994	0.999	0.996	0.999	0.999	0.993	0.983	1.002
180	0.0155	1.023	0.998	0.998	0.999	0.998	1.000	1.000	0.991	0.985	1.001
200	0.0172	1.068	1.000	1.002	1.000	1.000	1.000	1.000	0.989	0.986	1.000
220	0.0190	1.118	1.003	1.005	1.001	1.003	1.001	1.001	0.987	0.988	0.999
240	0.0207	1.173	1.005	1.009	1.002	1.005	1.003	1.001	0.984	0.989	0.998
260	0.0224	1.231	1.008	1.012	1.002	1.008	1.003	1.002	0.983	0.990	0.997
280	0.0241	1.294	1.010	1.016	1.003	1.010	1.004	1.002	0.980	0.991	0.997
293	0.0253	1.337	1.012	1.019	1.003	1.011	1.004	1.002	0.979	0.991	0.996
300	0.0258	1.361	1.013	1.021	1.003	1.013	1.004	1.003	0.979	0.992	0.996
320	0.0276	1.429	1.015	1.025	1.004	1.015	1.005	1.003	0.977	0.992	0.995
340	0.0293	1.501	1.018	1.028	1.005	1.017	1.006	1.004	0.975	0.993	0.994
360	0.0310	1.575	1.021	1.033	1.005	1.019	1.007	1.004	0.973	0.993	0.994
380	0.0327	1.649	1.023	1.037	1.006	1.022	1.008	1.005	0.971	0.994	0.993
400	0.0345	1.724	1.026	1.041	1.007	1.024	1.008	1.005	0.969	0.994	0.992
420	0.0362	1.799	1.029	1.045	1.007	1.027	1.009	1.006	0.967	0.995	0.991
440	0.0379	1.873	1.031	1.049	1.008	1.029	1.010	1.006	0.966	0.995	0.990
460	0.0396	1.947	1.034	1.053	1.009	1.031	1.011	1.007	0.964	0.995	0.990
480	0.0414	2.018	1.037	1.057	1.009	1.034	1.011	1.007	0.962	0.996	0.989
500	0.0431	2.088	1.040	1.062	1.010	1.036	1.012	1.008	0.961	0.996	0.988
520	0.0448	2.158	1.042	1.066	1.011	1.039	1.013	1.008	0.960	0.996	0.987
540	0.0465	2.223	1.045	1.071	1.011	1.041	1.014	1.009	0.958	0.996	0.987
560	0.0482	2.287	1.048	1.075	1.012	1.044	1.015	1.009	0.957	0.997	0.986
580	0.0500	2.349	1.051	1.080	1.013	1.047	1.015	1.010	0.955	0.997	0.985
600	0.0517	2.408	1.054	1.084	1.013	1.049	1.016	1.010	0.954	0.997	0.985

Table 2.2 Westcott g-factors ($149 \leq A \leq 176$).

T(K)	E(eV)	¹⁴⁹ Sm	¹⁵² Sm	¹⁵¹ Eu	¹⁵³ Eu	¹⁵⁵ Gd	¹⁵⁷ Gd	¹⁵⁶ Dy	¹⁵⁸ Dy	¹⁶⁰ Dy	¹⁶¹ Dy
20	0.0017	0.622	0.994	1.273	1.088	0.838	0.794	0.986	1.021	0.985	1.016
40	0.0034	0.656	0.995	1.251	1.078	0.865	0.824	0.988	1.019	0.987	1.014
60	0.0052	0.696	0.995	1.223	1.068	0.887	0.850	0.990	1.017	0.988	1.013
80	0.0069	0.743	0.996	1.193	1.057	0.904	0.871	0.992	1.015	0.990	1.011
100	0.0086	0.800	0.997	1.161	1.048	0.914	0.887	0.993	1.012	0.992	1.009
120	0.0103	0.867	0.997	1.129	1.038	0.919	0.898	0.994	1.010	0.994	1.007
140	0.0121	0.947	0.998	1.097	1.029	0.920	0.904	0.996	1.007	0.995	1.005
160	0.0138	1.036	0.999	1.067	1.020	0.918	0.905	0.997	1.005	0.997	1.003
180	0.0155	1.135	0.999	1.038	1.012	0.911	0.904	0.999	1.002	0.999	1.001
200	0.0172	1.239	1.000	1.010	1.003	0.903	0.899	1.001	1.000	1.000	0.999
220	0.0190	1.345	1.001	0.984	0.994	0.892	0.891	1.002	0.998	1.002	0.998
240	0.0207	1.452	1.002	0.959	0.986	0.880	0.882	1.004	0.995	1.004	0.996
260	0.0224	1.556	1.002	0.936	0.979	0.867	0.872	1.006	0.993	1.006	0.994
280	0.0241	1.656	1.003	0.914	0.971	0.853	0.860	1.008	0.991	1.008	0.992
293	0.0253	1.718	1.003	0.900	0.966	0.843	0.852	1.009	0.989	1.009	0.991
300	0.0258	1.749	1.003	0.893	0.963	0.838	0.847	1.009	0.988	1.009	0.991
320	0.0276	1.838	1.004	0.874	0.956	0.823	0.834	1.011	0.986	1.011	0.989
340	0.0293	1.918	1.005	0.856	0.949	0.808	0.821	1.013	0.984	1.013	0.987
360	0.0310	1.992	1.005	0.840	0.942	0.793	0.807	1.014	0.982	1.015	0.985
380	0.0327	2.058	1.006	0.825	0.935	0.778	0.793	1.016	0.979	1.016	0.984
400	0.0345	2.119	1.007	0.811	0.928	0.763	0.779	1.018	0.977	1.018	0.982
420	0.0362	2.172	1.007	0.799	0.922	0.749	0.765	1.019	0.975	1.020	0.980
440	0.0379	2.219	1.008	0.787	0.916	0.734	0.751	1.021	0.973	1.022	0.979
460	0.0396	2.260	1.009	0.777	0.910	0.720	0.737	1.023	0.971	1.024	0.977
480	0.0414	2.294	1.009	0.769	0.903	0.706	0.723	1.025	0.969	1.026	0.975
500	0.0431	2.325	1.010	0.761	0.897	0.692	0.710	1.026	0.966	1.028	0.974
520	0.0448	2.349	1.011	0.755	0.892	0.678	0.697	1.028	0.964	1.030	0.972
540	0.0465	2.370	1.011	0.750	0.886	0.665	0.684	1.030	0.962	1.031	0.970
560	0.0482	2.387	1.012	0.746	0.880	0.653	0.671	1.032	0.960	1.033	0.969
580	0.0500	2.400	1.013	0.744	0.875	0.640	0.659	1.033	0.958	1.035	0.967
600	0.0517	2.409	1.013	0.743	0.870	0.628	0.647	1.036	0.956	1.037	0.965

T(K)	E(eV)	¹⁶² Dy	¹⁶³ Dy	¹⁶⁴ Dy	¹⁶⁷ Er	¹⁶⁹ Tm	¹⁶⁸ Yb	¹⁷⁵ Lu	¹⁷⁶ Lu	¹⁷⁴ Hf	¹⁷⁶ Hf
20	0.0017	0.991	1.003	1.023	0.917	0.992	0.925	1.065	0.716	1.028	0.995
40	0.0034	0.993	1.002	1.021	0.926	0.993	0.933	1.057	0.744	1.025	0.996
60	0.0052	0.993	1.002	1.018	0.936	0.994	0.942	1.050	0.774	1.022	0.996
80	0.0069	0.994	1.001	1.015	0.945	0.995	0.951	1.042	0.808	1.019	0.997
100	0.0086	0.995	1.002	1.013	0.955	0.996	0.960	1.035	0.847	1.016	0.998
120	0.0103	0.996	1.001	1.010	0.965	0.997	0.969	1.028	0.892	1.012	0.998
140	0.0121	0.997	1.001	1.008	0.975	0.998	0.978	1.021	0.945	1.010	0.999
160	0.0138	0.998	1.001	1.005	0.986	0.999	0.987	1.015	1.010	1.006	0.999
180	0.0155	0.999	1.001	1.002	0.998	1.000	0.997	1.008	1.086	1.003	1.000
200	0.0172	1.000	1.001	0.999	1.008	1.001	1.007	1.003	1.176	1.000	1.000
220	0.0190	1.001	1.001	0.997	1.020	1.001	1.017	0.996	1.280	0.997	1.001
240	0.0207	1.002	1.002	0.994	1.033	1.003	1.028	0.991	1.395	0.994	1.001
260	0.0224	1.003	1.002	0.992	1.046	1.004	1.039	0.985	1.523	0.992	1.002
280	0.0241	1.004	1.003	0.989	1.059	1.005	1.050	0.980	1.658	0.988	1.002
293	0.0253	1.005	1.003	0.988	1.069	1.005	1.057	0.976	1.752	0.986	1.002
300	0.0258	1.005	1.003	0.987	1.073	1.005	1.061	0.975	1.802	0.985	1.003
320	0.0276	1.006	1.003	0.984	1.089	1.007	1.073	0.969	1.949	0.983	1.003
340	0.0293	1.007	1.004	0.982	1.104	1.008	1.086	0.964	2.099	0.980	1.004
360	0.0310	1.008	1.004	0.979	1.120	1.008	1.098	0.960	2.250	0.977	1.004
380	0.0327	1.009	1.005	0.976	1.138	1.010	1.111	0.955	2.399	0.974	1.005
400	0.0345	1.010	1.006	0.974	1.157	1.010	1.125	0.950	2.545	0.971	1.005
420	0.0362	1.011	1.006	0.972	1.177	1.012	1.139	0.946	2.688	0.968	1.006
440	0.0379	1.012	1.007	0.969	1.199	1.013	1.154	0.941	2.826	0.965	1.006
460	0.0396	1.013	1.008	0.967	1.222	1.013	1.170	0.937	2.959	0.963	1.007
480	0.0414	1.014	1.009	0.964	1.248	1.015	1.187	0.933	3.085	0.960	1.007
500	0.0431	1.015	1.010	0.962	1.276	1.016	1.204	0.929	3.205	0.957	1.008
520	0.0448	1.016	1.011	0.960	1.306	1.017	1.222	0.925	3.318	0.955	1.008
540	0.0465	1.017	1.012	0.957	1.339	1.018	1.242	0.921	3.424	0.952	1.009
560	0.0482	1.018	1.013	0.955	1.375	1.019	1.262	0.917	3.524	0.949	1.010
580	0.0500	1.019	1.014	0.952	1.415	1.020	1.283	0.914	3.618	0.947	1.010
600	0.0517	1.020	1.015	0.950	1.458	1.021	1.306	0.910	3.704	0.944	1.011

Table 2.3 Westcott g-factors ($A \geq 177$).

T(K)	E(eV)	¹⁷⁷ Hf	¹⁷⁸ Hf	¹⁷⁹ Hf	¹⁸⁰ Hf	¹⁸⁰ Ta	¹⁸¹ Ta	¹⁸⁰ W	¹⁸² W	¹⁸⁵ Re	¹⁸⁷ Re
20	0.0017	0.969	0.994	1.006	1.005	0.831	0.993	1.006	0.995	0.991	1.046
40	0.0034	0.973	0.995	1.005	1.005	0.850	0.994	1.005	0.995	0.991	1.040
60	0.0052	0.976	0.996	1.005	1.004	0.869	0.995	1.005	0.996	0.992	1.035
80	0.0069	0.979	0.996	1.004	1.003	0.889	0.996	1.004	0.997	0.993	1.030
100	0.0086	0.983	0.997	1.003	1.003	0.911	0.996	1.003	0.997	0.994	1.025
120	0.0103	0.987	0.997	1.003	1.003	0.935	0.997	1.003	0.997	0.995	1.020
140	0.0121	0.990	0.998	1.002	1.002	0.962	0.998	1.002	0.999	0.996	1.015
160	0.0138	0.994	0.999	1.001	1.001	0.991	0.999	1.002	0.999	0.997	1.011
180	0.0155	0.998	1.000	1.001	1.001	1.026	0.999	1.001	1.000	0.998	1.006
200	0.0172	1.002	1.000	1.000	1.000	1.065	1.000	1.000	1.000	0.999	1.002
220	0.0190	1.006	1.001	0.999	0.999	1.111	1.001	1.000	1.001	1.000	0.997
240	0.0207	1.010	1.002	0.999	0.999	1.166	1.002	0.999	1.002	1.001	0.993
260	0.0224	1.013	1.002	0.998	0.998	1.230	1.002	0.998	1.002	1.002	0.989
280	0.0241	1.017	1.003	0.997	0.997	1.304	1.003	0.998	1.003	1.004	0.985
293	0.0253	1.020	1.003	0.997	0.997	1.358	1.004	0.997	1.003	1.004	0.982
300	0.0258	1.021	1.003	0.996	0.997	1.389	1.004	0.997	1.003	1.004	0.981
320	0.0276	1.025	1.004	0.996	0.996	1.484	1.005	0.996	1.004	1.005	0.977
340	0.0293	1.029	1.005	0.995	0.995	1.589	1.005	0.996	1.004	1.007	0.973
360	0.0310	1.033	1.005	0.994	0.995	1.704	1.006	0.995	1.005	1.008	0.970
380	0.0327	1.038	1.006	0.994	0.994	1.829	1.007	0.994	1.005	1.009	0.966
400	0.0345	1.042	1.007	0.993	0.993	1.961	1.008	0.994	1.006	1.010	0.962
420	0.0362	1.046	1.007	0.992	0.993	2.101	1.008	0.993	1.007	1.011	0.959
440	0.0379	1.051	1.008	0.992	0.992	2.247	1.009	0.993	1.007	1.012	0.956
460	0.0396	1.055	1.008	0.991	0.992	2.398	1.010	0.992	1.008	1.013	0.952
480	0.0414	1.059	1.009	0.990	0.991	2.554	1.010	0.991	1.009	1.015	0.949
500	0.0431	1.064	1.010	0.990	0.990	2.713	1.011	0.991	1.009	1.016	0.946
520	0.0448	1.069	1.010	0.989	0.990	2.874	1.012	0.990	1.010	1.017	0.942
540	0.0465	1.073	1.011	0.988	0.989	3.039	1.013	0.989	1.010	1.018	0.939
560	0.0482	1.078	1.012	0.988	0.989	3.204	1.014	0.989	1.011	1.019	0.936
580	0.0500	1.083	1.013	0.987	0.988	3.370	1.014	0.988	1.012	1.020	0.933
600	0.0517	1.088	1.013	0.987	0.988	3.536	1.015	0.988	1.012	1.022	0.930

T(K)	E(eV)	¹⁸⁶ Os	¹⁸⁷ Os	¹⁹¹ Ir	¹⁹³ Ir	¹⁹⁷ Au	¹⁹⁶ Hg	¹⁹⁹ Hg	²³² Th	²³⁴ U	²³⁵ U
20	0.0017	1.005	1.035	1.018	0.973	0.991	1.023	1.021	1.008	1.019	1.173
40	0.0034	1.005	1.032	1.016	0.976	0.992	1.021	1.019	1.007	1.017	1.143
60	0.0052	1.004	1.027	1.014	0.979	0.993	1.018	1.016	1.006	1.015	1.119
80	0.0069	1.003	1.023	1.012	0.983	0.994	1.015	1.015	1.005	1.012	1.100
100	0.0086	1.003	1.020	1.010	0.985	0.995	1.013	1.012	1.005	1.010	1.083
120	0.0103	1.003	1.015	1.008	0.988	0.996	1.010	1.010	1.003	1.008	1.068
140	0.0121	1.002	1.012	1.006	0.992	0.997	1.008	1.007	1.003	1.006	1.054
160	0.0138	1.001	1.008	1.005	0.995	0.998	1.005	1.005	1.002	1.004	1.042
180	0.0155	1.001	1.004	1.003	0.998	0.999	1.002	1.002	1.001	1.001	1.031
200	0.0172	1.000	1.000	1.002	1.001	1.000	0.999	1.000	0.999	0.999	1.021
220	0.0190	1.000	0.996	1.001	1.005	1.001	0.997	0.997	0.999	0.998	1.012
240	0.0207	0.999	0.993	0.999	1.008	1.003	0.994	0.995	0.998	0.995	1.003
260	0.0224	0.998	0.989	0.998	1.011	1.003	0.992	0.993	0.997	0.993	0.995
280	0.0241	0.998	0.985	0.997	1.014	1.005	0.989	0.991	0.996	0.991	0.989
293	0.0253	0.998	0.983	0.996	1.017	1.005	0.988	0.989	0.995	0.990	0.985
300	0.0258	0.997	0.982	0.996	1.018	1.005	0.987	0.988	0.995	0.989	0.983
320	0.0276	0.997	0.978	0.995	1.022	1.006	0.984	0.986	0.994	0.987	0.977
340	0.0293	0.996	0.975	0.995	1.025	1.007	0.982	0.984	0.993	0.985	0.972
360	0.0310	0.996	0.971	0.994	1.029	1.008	0.979	0.981	0.992	0.983	0.967
380	0.0327	0.995	0.967	0.994	1.032	1.009	0.977	0.979	0.991	0.981	0.963
400	0.0345	0.994	0.964	0.994	1.036	1.010	0.974	0.977	0.990	0.979	0.960
420	0.0362	0.994	0.961	0.994	1.039	1.011	0.972	0.975	0.990	0.977	0.957
440	0.0379	0.993	0.957	0.994	1.043	1.012	0.969	0.973	0.989	0.975	0.954
460	0.0396	0.993	0.954	0.994	1.047	1.013	0.967	0.970	0.988	0.973	0.952
480	0.0414	0.992	0.950	0.994	1.051	1.014	0.965	0.968	0.987	0.972	0.950
500	0.0431	0.992	0.947	0.995	1.055	1.015	0.962	0.966	0.986	0.970	0.949
520	0.0448	0.991	0.944	0.996	1.059	1.016	0.960	0.964	0.985	0.968	0.948
540	0.0465	0.990	0.941	0.997	1.062	1.018	0.957	0.962	0.984	0.966	0.947
560	0.0482	0.990	0.937	0.998	1.066	1.018	0.955	0.960	0.983	0.964	0.946
580	0.0500	0.989	0.934	1.000	1.071	1.020	0.953	0.957	0.983	0.962	0.946
600	0.0517	0.989	0.931	1.001	1.075	1.021	0.951	0.955	0.982	0.960	0.946

2.2. Generalized formalism

2.2.1. Capture rate

The instantaneous neutron capture rate $dR(t)$ of a stable nuclide in differential volume $d^3\mathbf{r}$ localized at \mathbf{r} of a sample in a neutron field is given by :

$$dR(t) = d^3\mathbf{r} n_x(\mathbf{r}) \int_0^\infty n(\mathbf{r}, \nu, t) \sigma_\gamma(\nu) \nu d\nu \quad (13)$$

where $n_x(\mathbf{r})$ is the capturing nuclide density in the sample target, and $n(\mathbf{r}, \nu, t)$ is the neutron density per unit speed interval at location \mathbf{r} and time t . By preparing a target sample of homogeneous nuclide density, the time-averaged capture rate by the given nuclide in the sample is given by [2.14]:

$$\langle R \rangle = \frac{1}{t_m} \int_0^{t_m} dt \int_V d^3\mathbf{r} n_x(\mathbf{r}) \int_0^\infty n(\mathbf{r}, \nu, t) \sigma_\gamma(\nu) \nu d\nu = \frac{1}{V} \frac{m}{M} N_A \theta \int_V d^3\mathbf{r} \int_0^\infty n(\mathbf{r}, \nu) \sigma_\gamma(\nu) \nu d\nu \quad (14)$$

where t_m is the irradiation period, V is the volume of sample, m is the mass of the relevant element in the target, M is the atomic mass of the element, N_A is Avogadro's number, θ is the abundance of the capturing isotope in the element, and $n(\mathbf{r}, \nu)$ is the time-averaged neutron density per unit speed interval at location \mathbf{r} given by:

$$n(\mathbf{r}, \nu) = \frac{1}{t_m} \int_0^{t_m} dt n(\mathbf{r}, \nu, t) \quad (15)$$

The expressions are greatly simplified for $1/\nu$ absorbers. Using the relationship $\sigma(\nu) = \sigma_0 \nu_0 / \nu$, the capture rate in Equation (14) becomes proportional to the total neutron density in the sample, and is given by:

$$\langle R \rangle_{1/\nu} = \frac{1}{V} \frac{m}{M} N_A \theta \int_V d^3\mathbf{r} \int_0^\infty n(\mathbf{r}, \nu) \sigma_\gamma(\nu) \nu d\nu = \frac{m}{M} N_A \theta \sigma_0 \nu_0 \bar{n}_t \quad (16)$$

where \bar{n}_t is the volume-averaged total neutron density in the sample. The result is exact even when the spectrum in the sample is distorted or the neutron beam profile is inhomogeneous. Thus, for an approximately good $1/\nu$ absorber nuclide over the neutron spectral range, Equation (16) is valid to a reasonable degree. Hence, for a PGAA facility in which the neutron beam is free from an epithermal component, no detailed information about the incident beam spectrum nor the spectrum inside the sample is required for $1/\nu$ absorbers as far as k_0 standardization is concerned.

Capture rates of realistic nuclides with resonances in the epithermal region are composed of contributions by thermal and epithermal neutrons within the sample. This problem has been addressed in numerous INAA studies, in which the underlying assumptions are that the thermal neutron spectrum is Maxwellian and the epithermal flux is characterized by $1/E$ or $1/E^{1+\alpha}$. Since the beam spectrum in PGAA is closely described by a Maxwellian with or without a significant $1/E$ epithermal flux contribution, the existing formalism in INAA is judged to be equally applicable [2.25].

2.2.2. Non-1/v absorber, effective g-factor and Cd ratio

The capture rate for a non-1/v absorber has been quantified in terms of the Westcott g-factor. As the g-factor is defined for a Maxwellian thermal spectrum, one is faced with the problem of treating realistic neutron spectra, which may deviate significantly from the Maxwellian shape in the thermal energy region. Measured TOF spectra for super-mirror guided cold beams exhibit large deviations of this kind, which are difficult to parametrize [2.26]. The curved mirror guided thermal beam also has spatial inhomogeneity and results in deviations with respect to spectral correlation as a function of position along the mirror curvature [2.27]. Furthermore, the thermal spectrum deviates from Maxwellian in filtered beam facilities [2.28], where the spectrum form is distinctly non-Maxwellian [2.12, 2.29]. As the capture rate for a non-1/v absorber is highly dependent on the shape of the thermal and epithermal spectrum, a generalized approach is described in terms of an effective g-factor.

Even when the neutron spectrum is correlated with the neutron density in the sample, the reduction of the capture rate to measurable quantities is possible for a 1/v absorber. However, this correlation becomes more complex for a non-1/v absorber because the strong capture process causes spectral hardening at low energies and from self-shielding around the resonances. A thin sample with infinite (or sufficiently realistic) dilution of strong absorber nuclides is an important requirement to ensure that the neutron spectrum within the sample does not change compared to that of the incident beam. When the neutron density of the incident beam can be separated [$n(\mathbf{r}, \mathbf{v}) = n(\mathbf{r})\rho(\mathbf{v})$], this same separation process is valid for dilute thin samples and simplifies theoretical considerations. If the thermal spectrum deviates significantly from Maxwellian, the Høgdahl convention can be used to classify the thermal and epithermal neutrons in terms of cadmium cutoff [2.30], and the neutron density separates into two terms:

$$n(\mathbf{r}, \mathbf{v}) = n(\mathbf{r})\rho(\mathbf{v}) = n_{th}(\mathbf{r})\rho_{th}(\mathbf{v})\Theta(v_{Cd} - v) + n_{ep}(\mathbf{r})\rho_{ep}(\mathbf{v})\Theta(v - v_{Cd}) \quad (17)$$

where $n_{th}(\mathbf{r})$ and $n_{ep}(\mathbf{r})$ are local thermal and epithermal neutron density respectively, $\Theta(x)$ is the step function which is unity for the non-negative argument x and zero otherwise, and v_{Cd} is the neutron speed corresponding to the cadmium cutoff energy $E_{Cd} \sim 0.5$ eV (and $mv_{Cd}^2/2 \equiv E_{Cd}$). The speed distribution functions $\rho(v)$, $\rho_{th}(v)$ and $\rho_{ep}(v)$ are normalized so that:

$$\int_0^{\infty} \rho(v)dv = \int_0^{v_{Cd}} \rho_{th}(v)dv + \int_{v_{Cd}}^{\infty} \rho_{ep}(v)dv = 1 \quad (18)$$

Hence, the capture rate is given by:

$$\begin{aligned} \langle R \rangle_{non-1/v} &= \frac{1}{V} \frac{m}{M} N_A \theta \int_V d^3\mathbf{r} \ n(\mathbf{r}) \int_0^{\infty} \rho(v) \sigma_{\gamma}(v) v dv \\ &= \frac{m}{M} N_A \ \theta \left[\bar{n}_{th} \int_0^{v_{Cd}} \rho_{th}(v) \sigma_{\gamma}(v) v dv + \bar{n}_{ep} \int_{v_{Cd}}^{\infty} \rho_{ep}(v) \sigma_{\gamma}(v) v dv \right] \end{aligned} \quad (19)$$

where \bar{n}_{th} and \bar{n}_{ep} are the volume-averaged thermal and epithermal neutron densities in the sample, respectively. A general beam spectrum can be considered by including the epithermal capture rate in parallel.

Accordingly, an effective g-factor is defined in Ref. [2.31]:

$$\hat{g} \equiv \frac{1}{\sigma_0 v_0} \frac{\int_0^{v_{Cd}} \rho_{th}(v) \sigma_\gamma(v) v dv}{\int_0^{v_{Cd}} \rho_{th}(v) dv} = \frac{1}{\sigma_0 v_0} \int_0^{v_{Cd}} \rho_{th}(v) \sigma_\gamma(v) v dv \quad (20)$$

for the realistic thermal neutron spectrum $\rho_{th}(v)$ of the incident beam. Therefore, the effective g-factor for a given non-1/v absorber nuclide is specific for a particular PGAA beam facility, and is unity for an exact 1/v absorber, regardless of the spectral shape. If resonances are present above E_{Cd} and if the epithermal neutron contribution to the reaction rates is not negligible, the definition of the effective g-factor is still valid, but the second integral in Equation (19) must be accounted for explicitly. Procedures developed for INAA can be applied. Generally, the effective g-factor depends on E_{Cd} , but this dependence is usually weak, except for a few nuclides (^{176}Lu , ^{151}Eu , ^{115}In , etc.) with strong resonances near this energy.

If detailed information about the neutron spectral shape is available, the effective g-factors can be calculated from the pointwise capture cross sections (e.g. JEF-2.2 dataset [2.32]). However, there are additional complications that may arise when a cold beam is incident on the target at room temperature. The neutron energy gain by up-scattering in the target can lead to spectral distortion, which is difficult to predict and complicates the interpretation of measurements of non-1/v absorbers [2.33].

Effective g-factors for a particular PGAA facility can be determined by measuring the k_0 factors (described in Section 2.2.4) and comparing them to reference values from the literature. According to Equation (1), k_0 factors are composite nuclear constants independent of the facility. Therefore, if the k_0 value is known, it is possible to determine the ratio of the effective g-factor of the measured nuclide and the comparator, which is normally a 1/v absorber with the g-factor equal to one.

The epithermal contribution to the capture rate of a nuclide can be estimated from the measured cadmium ratio (R_{Cd}), which is the ratio of the specific activities of this nuclide in the sample irradiated without and with a cadmium cover. Activity is proportional to the reaction rate which can be calculated by defining the cadmium transmission function, assuming exponential neutron attenuation through the cadmium cover:

$$t(v) = \exp[-d n_{Cd} \sigma_{Cd}(v)] \quad (21)$$

where d is the cadmium cover thickness, n_{Cd} is the cadmium number density, and σ_{Cd} is the cadmium cross section. The cadmium ratio is given by:

$$R_{Cd} = \frac{\bar{n} \int_0^\infty \rho(v) \sigma_\gamma(v) v dv}{\bar{n} \int_0^\infty t(v) \rho(v) \sigma_\gamma(v) v dv} \quad (22)$$

Due to the nature of the cadmium cross section, the transmission function is close to unity above the cadmium resonance at about 0.5 eV and nearly zero below. This parameter can be approximated by an idealized Heaviside function, with a step from zero to one at speed v_{Cd} , to give a greatly simplified expression for the cadmium ratio:

$$R_{Cd} = \frac{\left[\bar{n}_{th} \int_0^{v_{Cd}} \rho_{th}(v) \sigma_\gamma(v) v dv + \bar{n}_{ep} \int_{v_{Cd}}^{\infty} \rho_{ep}(v) \sigma_\gamma(v) v dv \right]}{\bar{n}_{ep} \int_{v_{Cd}}^{\infty} \rho_{ep}(v) \sigma_\gamma(v) v dv} = 1 + \frac{\bar{n}_{th} v_0 \hat{g} \sigma_0}{\bar{n}_{ep} \int_{v_{Cd}}^{\infty} \rho_{ep}(v) \sigma_\gamma(v) v dv}, \quad (23)$$

and the capture rate is given by:

$$\langle R \rangle_{\text{non-1/v}} = \frac{m}{M} N_A \theta \bar{n}_{th} v_0 \hat{g} \sigma_0 \left(\frac{R_{Cd}}{R_{Cd} - 1} \right) \quad (24)$$

which is a generalized expression for Eq. (16). By comparing Equations (22) and (23), an effective cadmium cutoff speed (v_{Cd}) can be determined that depends mainly on the thickness of the cadmium cover. Dependence on the shape of the cross section is weak, except for nuclides with resonances near the cadmium cutoff speed. Cd cutoff energies have been determined for various Cd thicknesses, epithermal neutron components and beam geometries that are applicable to Maxwellian thermal spectra and 1/E epithermal spectra above $\sim 5kT$ [2.19, 2.20, 2.34].

When the Cd ratio is too large to obtain a statistically meaningful γ -count rate, the terms in Equation (24) that involve the Cd ratio are not required. The estimated lower limit of the Cd ratio can be used to assign the error arising from epithermal neutron contribution.

2.2.3. Prompt capture- γ counting rate

The measured count rate of a prompt γ ray of energy E_γ emitted from a capturing nuclide is given by:

$$\langle C \rangle = \frac{1}{V} \frac{m}{M} N_A \theta \int_V d^3 \mathbf{r} \varepsilon(\mathbf{r}, E_\gamma) \int_0^{\infty} P(E_\gamma, v) n(\mathbf{r}, v) \sigma_\gamma(v) v dv \quad (25)$$

where $\varepsilon(\mathbf{r}, E_\gamma)$ is the detection efficiency for the prompt γ ray of energy E_γ emitted at location \mathbf{r} , and $P(E_\gamma, v)$ is the absolute γ -ray emission probability (gammas emitted per capture) of the prompt γ ray of energy E_γ emitted from the nucleus capturing a neutron of speed v .

Using a small sample, the detection efficiency $\varepsilon(\mathbf{r}, E_\gamma)$ is assumed to have the same shape over the sample volume and is separable into $f(\mathbf{r})\varepsilon(E_\gamma)$ where $f(\mathbf{r})$ is a geometrical factor independent of the γ -ray energy, unless attenuated [2.14]. A high resolution gamma-ray spectroscopy system is assumed for the detection, consisting of a single or Compton-suppressed semiconductor detector and associated electronics. Typically, the sample should be as small as practicable (point source) and located 15-20 cm or more from the detector so that the effects of the gradient of the detection efficiency through the sample is negligible [2.22]. Gamma-ray attenuation within the sample is insignificant due to the small sample size and high prompt γ -ray energy (greater than 200 keV). Typical correction factors arise from sum coincidence, random coincidence and dead time losses, and are introduced during or after the measurement. Typical corrections for saturation, cooling and decay before and during the counting period are not required.

The absolute γ -ray emission probability $P(E_\gamma, v)$ is dependent on the captured neutron speed (energy) [2.28]. This parameter is related to the partial capture cross section and partial radiative width, which fluctuates from resonance to resonance (Porter-Thomas fluctuation

[2.35]). Neutron capture models based on statistical theory [2.36] or simple direct (potential) capture [2.37-2.39] predict negligible energy dependence for $P(E_\gamma, v)$ in the thermal region. However, the neutron energy dependence can only be appreciable when interference occurs [2.40, 2.41] either between different resonance amplitudes [2.42] or between resonance and direct capture amplitudes [2.43]. Such experimental studies are difficult to perform and are scarce, especially in the thermal and cold energy range. Some signatures have been determined for a few transitions from $^{238}\text{U}(n, \gamma)$ [2.44], $^{197}\text{Au}(n, \gamma)$ [2.45], $^{195}\text{Pt}(n, \gamma)$ [2.42], $^{169}\text{Tm}(n, \gamma)$ [2.46] and $^{149}\text{Sm}(n, \gamma)$ [2.47] resonances that influence the thermal region. Even though there is some experimental evidence and theoretical models that support the energy variation in P , quantitative prediction of this phenomenon requires further study beyond the present scope. For most nuclides, the slow neutron energy region (< 0.1 eV) is far from the lowest positive energy resonance (e.g., Table 2.4 [2.48]), while the negative energy resonance is closest to the neutron threshold. Hence, the absolute γ -ray emission probability $P(E_\gamma)$ is assumed to be independent of the neutron energy for slow neutron capture. Data for absolute γ -ray emission probabilities are based on the incident neutron energy being thermal, as specified in the current PGAA database [2.49].

Table 2.4 Energy (eV)-ordered resonances.*

E_0	Isotope	E_0	Isotope	E_0	Isotope	E_0	Isotope	E_0	Isotope
0.031	^{157}Gd	0.178	^{242}Am	0.307	^{241}Am	0.546	^{192}Ir	0.653	^{191}Ir
0.084	^{135}Xe	0.192	^{154}Eu	0.321	^{151}Eu	0.574	^{241}Am	0.702	^{249}Cf
0.097	^{149}Sm	0.195	^{249}Bk	0.400	^{231}Pa	0.584	^{167}Er	0.807	^{169}Yb
0.141	^{176}Lu	0.200	^{180}Ta	0.435	^{180}Ta	0.597	^{168}Yb	0.872	^{149}Sm
0.148	^{182}Ta	0.256	^{192}Ir	0.460	^{151}Eu	0.603	^{155}Eu	0.884	^{152}Eu
0.169	^{148}Pm	0.258	^{241}Pu	0.460	^{167}Er	0.609	^{229}Th	1.000	^{252}Cf
0.178	^{113}Cd	0.296	^{239}Pu	0.489	^{237}Np	0.615	^{242}Am	1.060	^{240}Pu

* extracted from Appendix A of Ref. [2.48].

By combining Equations (24) and (25), the specific count rate (per mass of element in the sample, or the so-called analytic sensitivity) is given by:

$$A = \left\langle \frac{C}{m} \right\rangle = \frac{N_A}{M} \theta P(E_\gamma) \epsilon(E_\gamma) \bar{n}_{\text{th}} v_0 \hat{g} \sigma_0 \left(\frac{R_{\text{Cd}}}{R_{\text{Cd}} - 1} \right). \quad (26)$$

2.2.4. Experimental k_0 factor

The same irradiation conditions for analyte (x) and comparator (c) elements are achieved by co-irradiating a homogeneous mixture of analyte and comparator element in a neutron field, and measuring the signature of prompt gamma rays in parallel. Hence, the experimental prompt k_0 factor is given from Equations (1) and (26) by:

$$k_0 \equiv \frac{P_x(E_{\gamma,x}) \cdot \sigma_{0,x} \cdot \theta_x / M_x}{P_c(E_{\gamma,c}) \cdot \sigma_{0,c} \cdot \theta_c / M_c} = \frac{A_x / \varepsilon(E_{\gamma,x}) \cdot \hat{g}_c}{A_c / \varepsilon(E_{\gamma,c}) \cdot \hat{g}_x} \cdot \frac{\left(\frac{R_{Cd}}{R_{Cd} - 1} \right)_c}{\left(\frac{R_{Cd}}{R_{Cd} - 1} \right)_x} \quad (27)$$

This general expression contains two correction factors: \hat{g} for non-1/v absorption, and R_{Cd} for epithermal absorption. Typical comparator elements H and Cl are both good 1/v absorbers with effective g-factors close to unity in most facilities. The last term in parentheses deviates from unity by about $(1/R_{Cd})_c - (1/R_{Cd})_x$ and therefore is closer to unity for a clean beam. Guided or filtered neutron beams result in conditions that do not require epithermal correction.

Accurately determined k_0 factors permit the generation of precisely measured datasets of partial cross sections by normalization to the well-defined comparator element H. Datasets of partial cross sections are known to be considerably more precise than either the isotopic cross section (σ_0) or the absolute γ -ray emission probability (P) [2.49]. Hence, by measuring the ratio of gamma-ray emission rates for two selected elements and using the known k_0 factors, the concentration ratio of the two elements can be precisely determined. Furthermore, the absolute elemental concentrations could be obtained if all the elements in the sample are observed in the measured gamma-ray spectrum (elemental analysis of a sample).

2.3. Concluding remarks

Typical spectra of the neutron beams used for PGAA deviate appreciably from the ideal Maxwellian function. Although analysis in terms of k_0 -standardization has been expanded to non-1/v absorbers, the resulting deviation is neglected and the thermal spectrum has been approximated by the Maxwellian with or without 1/E epithermal contribution so that developments in INAA apply. Since the majority of nuclides exhibit 1/v absorption in the thermal energy region and even the non-1/v absorbers behave asymptotically as 1/v absorbers in the cold region (below 5 eV), the analytical solution is relatively simple in most cases. Quantification of the various effects becomes important as the accuracy in the measured k_0 factors is reported to be less than 3% (typically around 1%). Therefore, highly accurate PGAA requires well-defined experimental conditions and procedures, along with the analytical data and the assumptions underlying the final result. PGAA applications are widely diverse in terms of the sample composition and size, neutron beam characteristics, analysis method and procedure, and therefore the validity and limitations of the present approach need to be considered in greater detail.

REFERENCES

- [2.1] THOMAS, G.E., BLATCHLEY, D.E., BOLLINGER, L.M., High-sensitivity Neutron-capture Gamma-ray Facility, Nucl. Instrum. Meth. **56** (1967) 325-337.
- [2.2] NICHOL, L., LOPEZ, A., ROBERTSON, A., PRESTWICH, W.V., KENNETT, T.J., A Versatile Tangential Irradiation Facility, Nucl. Instrum. Meth. **81** (1970) 263-269.
- [2.3] ANDERSON, D.L., FAILEY, M.P., ZOLLER, W.H., WALTERS, W.B., GORDON, G.E., LINDSTROM, R.M., Facility for Non-destructive Analysis for Major and Trace Elements Using Neutron-capture Gamma-ray Spectrometry, J. Radioanal. Nucl. Chem. **63** (1981) 97-119.

- [2.4] YONEZAWA, C., WOOD, A.K.H., HOSHI, M., ITO, Y., TACHIKAWA, E., The Characteristics of the Prompt Gamma-ray Analyzing System at the Neutron Beam Guides of JRR-3M, Nucl. Instrum. Meth. Phys. Res. **A329** (1993) 207-216.
- [2.5] MOLNÁR, G.L., BELGYA, T., DABOLCZI, L., FAZEKAS, B., RÉVAY, Zs., VERES, Á., BIKIT, I., KIS, Z., ÖSTÖR, J., The New Prompt Gamma-activation Analysis Facility at Budapest, J. Radioanal. Nucl. Chem. **215** (1997) 111-115.
- [2.6] SUDARSHAN, K., NAIR, A.G.C., ACHARYA, R.N., SCINDIA, Y.M., REDDY, A.V.R., MANOHAR, S.B., GOSWAMI, A., Capture γ -rays from ^{60}Co as Multi γ -ray Efficiency Standard for Prompt γ -ray Neutron Activation Analysis, Nucl. Instrum. Meth. Phys. Res. **A457** (2001) 180-186.
- [2.7] LINDSTROM, R.M., ZEISLER, R., VINCENT, D. H., GREENBERG, R. R., STONE, C. A., ANDERSON, D. L., CLARK, D. D., MACKEY, E. A., Neutron Capture Prompt Gamma-ray Activation Analysis at the NIST Cold Neutron Research Facility, J. Radioanal. Nucl. Chem. **167** (1993) 121-126.
- [2.8] CRITTIN, M., KERN, J., SCHENKER, J.-L., The New Prompt Gamma-ray Activation Facility at the Paul Scherrer Institute Switzerland, Nucl. Instrum. Meth. Phys. Res. **A449** (2000) 221-236.
- [2.9] RÉVAY, Zs., BELGYA, T., KASZTOVSZKY, Zs., WEIL, J.L., MOLNÁR, G.L., "Cold Neutron PGAA Facility at Budapest," Nucl. Instrum. Meth. Phys. Res. **B213** (2004) 385-388.
- [2.10] HANNA, A.G., BRUGGER, R.M., GLASCOCK, M.D., The Prompt Gamma Neutron Activation Analysis Facility at MURR, Nucl. Instrum. Meth. **188** (1981) 619-627.
- [2.11] HARLING, O.K., CHABEUF, J.-M., LAMBERT, F., YASUDA, G., A Prompt Gamma Neutron Activation Analysis Facility Using a Diffracted Beam, Nucl. Instrum. Meth. Phys. Res. **B83** (1993) 557-562.
- [2.12] BYUN, S.H., SUN, G.M., CHOI, H.D., Development of a Prompt Gamma Activation Analysis Facility Using Diffracted Polychromatic Neutron Beam, Nucl. Instrum. Meth. Phys. Res. **A487** (2002) 521-529.
- [2.13] DE CORTE, F., SIMONITS, A., DE WISPELAERE, A., HOSTE, J., Accuracy and Applicability of the k_0 -standardization Method, J. Radioanal. Nucl. Chem. **113** (1987) 145-161.
- [2.14] LINDSTROM, R.M., FLEMING, R.F., PAUL, R.L., MACKEY, E.A., "The k_0 Approach in Cold-neutron Prompt-gamma Activation Analysis," Proc. Int. k_0 Users Workshop (De Corte, F., Editor) Universiteit Gent, Gent (1992) 121-124.
- [2.15] MOLNÁR, G.L., RÉVAY, Zs., PAUL, R.L., LINDSTROM, R.M., Prompt-gamma Activation Analysis Using the k_0 Approach, J. Radioanal. Nucl. Chem. **234** (1998) 21-26.
- [2.16] SIMONITS, A., DE CORTE, F., HOSTE, J., Single-comparator Methods in Reactor Neutron Activation Analysis, J. Radioanal. Nucl. Chem. **24** (1975) 31-46.
- [2.17] MOLNÁR, G.L., "Development of a Database for Prompt γ -ray Neutron Activation Analysis," Summary report of first IAEA Research Coordination Meeting, INDC(NDS)-411, Vienna, Austria (2000) 47-52.
- [2.18] PRESTWICH, W.V., ISLAM, M.A., KENNETT, T.J., A Determination of the Carbon Thermal Neutron Capture Cross Section, Nucl. Sci. Eng. **78** (1981) 182-185.
- [2.19] WESTCOTT, C.H., WALKER, W.H., ALEXANDER, T.K., "Effective Cross Sections and Cadmium Ratios for the Neutron Spectra of Thermal Reactors," Peaceful Uses of Atomic Energy, Proc. 2nd UN Int. Conf. Geneva, 1958, Vol. 16, United Nations, Geneva (1958) 70-76.

- [2.20] STOUGHTON, R.W., HALPERIN, J., Heavy Nuclide Cross Sections of Particular Interest to Thermal Reactor Operation: Conventions, Measurements and Preferred Values, Nucl. Sci. Eng. **6** (1959) 100-118.
- [2.21] RYVES, T.B., PAUL, E.B., The Construction and Calibration of a Standard Thermal Neutron Flux Facility at the National Physical Laboratory, J. Nucl. Energy **22** (1968) 759-775.
- [2.22] LINDSTROM, R.M., YONEZAWA, C., "Prompt-Gamma Activation Analysis With Guided Neutron Beams," Prompt Gamma Neutron Activation Analysis (Alfassi, Z. B., Chung, C., Editors) CRC Press, Boca Raton (1995) 93-100.
- [2.23] HOLDEN, N.E., Temperature Dependence of the Westcott g-factor for Neutron Reactions in Activation Analysis, Pure Appl. Chem. **71** (1999) 2309-2315.
- [2.24] SUBLET, J-Ch., KOPECKY, J., FORREST, R.A., "The European Activation File: EAF-99 Cross Section Library," EURATOM/UKAEA Fusion Report, UKAEA FUS 408 (1998).
- [2.25] DE CORTE, F., SIMONITS, A., DE WISPELAERE, A., k_0 -measurements and Related Nuclear Data Compilation for (n, γ) Reactor Neutron Activation Analysis, J. Radioanal. Nucl. Chem. **133** (1989) 3-41.
- [2.26] BAUER, G.S., Operation and Development of the New Spallation Neutron Source SINQ at the Paul Scherrer Institut, Nucl. Instrum. Meth. Phys. Res. **B139** (1998) 65-71.
- [2.27] KAWABATA, Y., SUZUKI, M., SAKAMOTO, M., HARAMI, T., TAKAHASHI, H., ONISHI, N., Transmission Efficiency of Neutron Guide Tube With Alignment Errors, J. Nucl. Sci. Technol. **27** 5 (1990) 406-415.
- [2.28] LONE, M.A., MUGHABGHAB, S.F., PAVIOTTI-CORCUERA, R., "Development of a Database for Prompt γ -ray Neutron Activation Analysis," Summary report of second IAEA Research Coordination Meeting, INDC(NDS)-424, Vienna, Austria (2001) 85-92.
- [2.29] BYUN, S.H., SUN, G.M., CHOI, H.D., Characterization of a Polychromatic Neutron Beam Diffracted by Pyrolytic Graphite Crystals, Nucl. Instrum. Meth. Phys. Res. **A490** (2002) 538-545.
- [2.30] HÖGDAHL, O.T., "Neutron Absorption in Pile Neutron Activation Analysis Determination of Copper and Gold in Silver," Proc. Symp. Radiochemical Methods of Analysis, Salzburg, 1964, Vol. I, Vienna (1965) 23-40.
- [2.31] SUN, G.M., BYUN, S.H., CHOI, H.D., Prompt k_0 -factors and Relative γ -emission Intensities for the Strong Non-1/v Absorbers ^{113}Cd , ^{149}Sm , ^{151}Eu and $^{155,157}\text{Gd}$, J. Radioanal. Nucl. Chem. Vol. **256** (2003) 541-542.
- [2.32] JEF-2.2 Nuclear Data Library, OECD Nuclear Energy Agency (2000).
- [2.33] PAUL, R.L., The Use of Element Ratios to Eliminate Analytical Bias in Cold Neutron Prompt Gamma-ray Activation Analysis, J. Radioanal. Nucl. Chem. **191** (1995) 245-256.
- [2.34] DAYTON, I.E., PETTUS, W.G., Effective Cadmium Cutoff Energy, Nucleonics **15** (1957) 86-88.
- [2.35] PORTER, C.E., THOMAS, R.G., Fluctuations of Nuclear Reaction Widths, Phys. Rev. **104** (1956) 483-491.
- [2.36] BLATT, J.M., WEISSKOPF, V.F., "Theoretical Nuclear Physics," Wiley, New York (1960) 647-651.
- [2.37] LANE, A.M., LYNN, J.E., Theory of Radiative Capture in the Resonance Region, Nucl. Phys. **17** (1960) 563-585.
- [2.38] MUGHABGHAB, S.F., Verification of the Lane-Lynn Theory of Direct Neutron Capture, Phys. Lett. **81B** (1979) 93-97.

- [2.39] MUGHABGHAB, S.F., LONE, M.A., ROBERTSON, B.C., Quantitative Test of the Lane-Lynn Theory of Direct Radiative Capture of Thermal Neutrons by ^{12}C and ^{13}C , Phys. Rev. **C26** (1982) 2698-2701.
- [2.40] LANE, A.M., LYNN, J.E., Anomalous Radiative Capture in the Neutron Resonance Region: Analysis of the Experimental Data on Electric Dipole Transitions, Nucl. Phys. **17** (1960) 586-608.
- [2.41] LYNN, J.E., "The Theory of Neutron Resonance Reactions," Clarendon, Oxford (1968) 339-345.
- [2.42] COTÉ, R.E., BOLLINGER, L.M., Interference in the Radiative Capture of Neutrons, Phys. Rev. Lett. **6** (1961) 695-697.
- [2.43] WASSON, O.A., BHAT, M.R., CHRIEN, R.E., LONE, M.A., BEER, M., Direct Neutron Capture in $\text{Co}^{59}(\text{n}, \gamma)\text{Co}^{60}$, Phys. Rev. Lett. **17** (1966) 1220-1222.
- [2.44] PRICE, D.L., CHRIEN, R.E., WASSON, O.A., BHAT, M.R., BEER, M., LONE, M.A., GRAVES, R., Neutron Capture in ^{238}U , Nucl. Phys. **A121** (1968) 630-654.
- [2.45] WASSON, O.A., CHRIEN, R.E., BHAT, M.R., LONE, M.A., BEER, M., $\text{Au}^{197}(\text{n}, \gamma)\text{Au}^{198}$ Reaction Mechanism, Phys. Rev. **173** (1968) 1170-1184.
- [2.46] LONE, M.A., CHRIEN, R.E., WASSON, O.A., BEER, M., BHAT, M.R., MUETHER, H.R., Resonant and Nonresonant Capture of Slow Neutrons in $\text{Tm}^{169}(\text{n}, \gamma)\text{Tm}^{170}$, Phys. Rev. **174** (1968) 1512-1524.
- [2.47] BEČVÁŘ, F., CHRIEN, R.E., WASSON, O.A., A Study of the Distribution of Partial Radiative Widths and Amplitudes for $^{149}\text{Sm}(\text{n}, \gamma)^{150}\text{Sm}$, Nucl. Phys. **A236** (1974) 198-224.
- [2.48] MUGHABGHAB, S.F., Appendix A in "Neutron Cross Sections", Vol. 1, Part B, Z = 61 - 100, Academic Press, New York, 1984.
- [2.49] FIRESTONE, R.B., Database of IAEA Coordinated Research Project for Prompt Gamma-Ray Neutron Activation Analysis (2002), <http://ie.lbl.gov/pgadatabase/pgaa.htm>

3. CHARACTERISTICS OF PGAA FACILITIES

H.D. Choi

3.1. SNU-KAERI PGAA facility and diffracted polychromatic neutron beam

The SNU-KAERI Prompt Gamma Activation Analysis (PGAA) facility was developed through the joint efforts of Seoul National University (SNU) and Korea Atomic Energy Research Institute (KAERI), and has been operational since May 2001. A detailed layout of the facility is shown in Fig. 3.1. The PGAA system is installed on a platform located at the exit of the 4-m long ST1 tangential beam port of Hanaro [3.1]. Pyrolytic graphite (PG) crystals are used to extract the thermal beam by the method of Bragg diffraction, with the Bragg angle set at 45° so that most of the beam flux originates from diffraction orders 2, 3 and 4. The diffracted beam is diverted vertically to the first collimator positioned downstream from the PG crystals, and is controlled further by a second collimator of ^6LiF positioned on the beam shutter. The neutron flux and Cd-ratio for gold at the sample location are $7.9 \times 10^7 \text{ n cm}^{-2} \text{ s}^{-1}$ and 266, respectively. Flux uniformity of within 12% is achieved in the central area of $1 \times 1 \text{ cm}^2$ of the total beam cross section (of $2 \times 2 \text{ cm}^2$).

The neutron beam spectrum has been characterized both experimentally and theoretically [3.1, 3.2]. A time-of-flight (TOF) spectrometer was used to measure the spectrum of the diffracted polychromatic beam, as shown in Fig. 3.2. Bragg peaks up to 6th-order diffraction are recognizable, and hence the measurement is only restricted in the thermal energy region. Higher-order diffractions above 6th order and the epithermal region of the spectrum were obtained indirectly by comparing theoretical predictions with the measured effective cross section for the $^{10}\text{B}(n, \alpha)$ reaction and Cd-ratios for various nuclides.

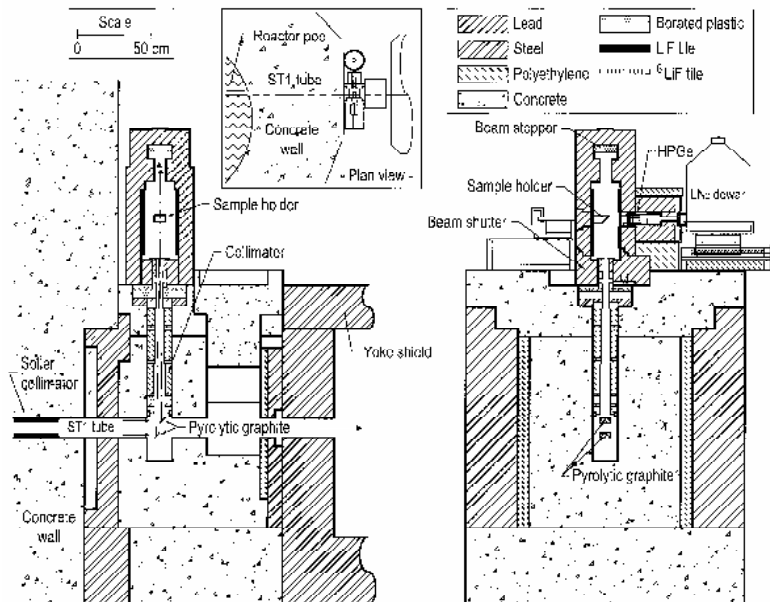

FIG. 3.1 SNU-KAERI PGAA facility.

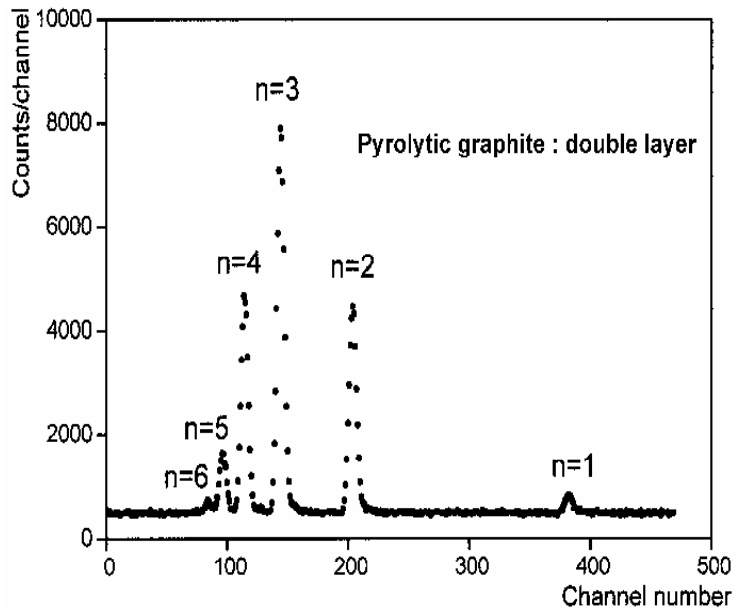

FIG.3. 2 Diffracted neutron TOF spectrum measured by double-layered crystals set at a Bragg angle of 45° .

The theoretical diffracted beam spectrum was obtained from the reflectivity model of the PG crystal. Lattice vibration effects were included in the calculation using the reported vibrational amplitude of the PG crystal and comparing with the measured time-of-flight spectra in the thermal region [3.3]. A continuous spectrum of background neutrons was included as a minor component that originated mainly from the incoherent scattering by the structural materials of the PG crystal mount and goniometer. The calculated neutron spectrum up to 40 eV is shown in Fig. 3.3, while the neutron flux and energy width of each diffraction order up to $n = 15$ was compared with the TOF measurement in Table 3.1. The energy width was determined theoretically considering the mosaic spread of the PG crystal and the angular divergence of the white neutron beam. Cadmium ratios for Au, Cl, Cd, Sm, Eu and Gd, and the effective cross section of the $^{10}\text{B}(n, \alpha)$ reaction were measured and compared with theoretical calculations based on the spectrum and pointwise neutron cross sections. These theoretical

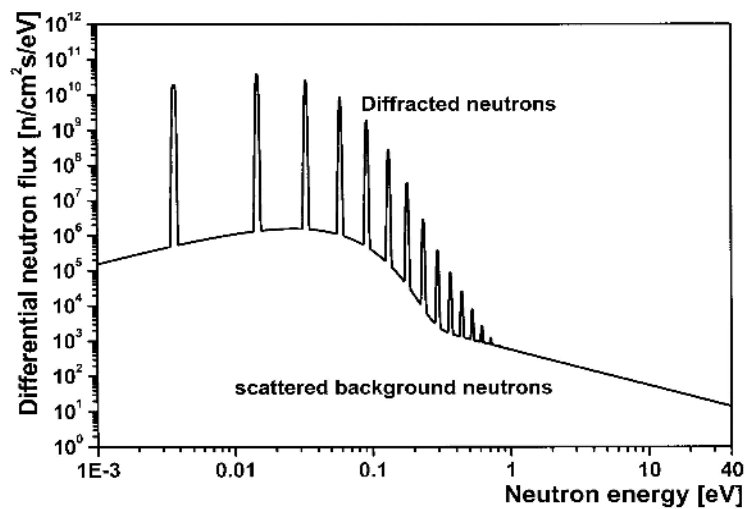

FIG. 3.3 Neutron spectrum at the sample position of SNU-KAERI PGAA facility.

Table 3.1 Relative fraction of the diffracted neutron flux as a function of diffraction order.

Diffraction Order (n)	Energy [meV]	Width [meV]	Relative flux [%]	
			TOF measurement	Theoretical calculation
1	3.6	0.2	4.4 ± 0.2	5.2
2	14.6	0.7	25.9 ± 0.2	29.6
3	32.8	1.5	39.3 ± 0.3	36.4
4	58.3	2.6	22.9 ± 0.2	20.4
5	91.0	4.1	6.2 ± 0.1	6.7
6	131.1	5.9	1.3 ± 0.1	1.4
7	178.4	8.0	n/d	2.1×10^{-1}
8	233.0	10.4	n/d	2.5×10^{-2}
9	294.9	13.2	n/d	4.1×10^{-3}
10	364.1	16.3	n/d	1.2×10^{-3}
11	440.5	19.7	n/d	4.0×10^{-4}
12	524.3	23.4	n/d	1.3×10^{-4}
13	615.3	27.5	n/d	4.0×10^{-5}
14	713.6	31.9	n/d	1.1×10^{-5}
15	819.1	36.6	n/d	3.0×10^{-6}

n/d - not detected.

predictions were consistent with the measured quantities, even though the agreement was not perfect.

The measured effective wavelength and velocity of the beam are $1.87 \pm 0.02 \text{ \AA}$ and $2117 \pm 21 \text{ m s}^{-1}$, respectively. All of the measured Cd-ratios except that for Au are in the range of 340 to 410, and hence the epithermal neutrons have negligible impact on the capture rate. Details of the method of analysis and the results are reported in Refs. [3.2] and [3.3].

A gamma-ray detector (n-type/HPGe, with a relative efficiency of 43%) is normally placed a distance of 25 cm from the sample. The pulse processing system consists of a preamplifier with resistive feedback, amplifier, 16k ADC, multichannel buffer and a PC with Ethernet connection to the buffer. Data collection and on-line analysis of the spectra are undertaken by commercial software, while off-line analysis is carried out by HYPERMET [3.4]. The total background counting rate for a neutron beam incident on a blank target is approximately $3000 \text{ counts s}^{-1}$, while the ADC deadtime is less than a few percent. Most of the background gamma-ray peaks identified are nitrogen and germanium capture lines, along with gamma rays originating from the inelastic excitation of Ge isotopes. Several methods have been proposed to reduce the background in a future upgrade. Radiation levels around the lead wall and sample position are kept low to ensure safety, with measured γ -ray and neutron dose rates of 10 and 30 \mu Sv h^{-1} , respectively. Both the efficiency and energy calibration of the detection system are determined according to the procedures adopted by the Budapest group [3.5, 3.6]. Full energy peak efficiency is determined by fitting polynomials to the measured data; relative standard uncertainty is $< 3\%$ over the low-energy region, and $< 5\%$ for the complete spectrum. Non-linearity of the spectrometer is determined in a similar manner by fitting a polynomial function to the observed data for accurately known gamma-ray lines [3.7].

Table 3.2 Measured sensitivities and detection limits for some elements.

Element	Energy [keV]	Sensitivity [counts s ⁻¹ mg ⁻¹]	Detection limit [μg]
H	2223	4.322 ± 0.005	11.500 ± 0.001
B	478	2131 ± 40	0.067 ± 0.001
Cl	1165	4.170 ± 0.020	11.500 ± 0.001
K	770	0.532 ± 0.010	105.00 ± 0.07
Ti	1382	2.023 ± 0.010	23.600 ± 0.001
Cd	558	452 ± 10	0.165 ± 0.001
Sm	333	2663 ± 40	0.043 ± 0.001
Gd	182	3071 ± 40	0.057 ± 0.001

The facility was first used to determine the sensitivity for boron. Dilute boric acid was used to prepare the solid samples, and a sensitivity of 2131 counts s⁻¹ (mg-B)⁻¹ was derived from the 478 keV Doppler-broadened peak. Sensitivities for various elements are listed in Table 3.2, along with the detection limits for a counting period of 10,000 s [3.1]. Since the neutron spectrum is simple and well-defined, k₀-standardization can be applied in the study of non-1/v absorbers. The k₀-factors and relative γ-ray emission intensities have been measured for ¹¹³Cd, ¹⁴⁹Sm, ¹⁵¹Eu and ^{155, 157}Gd [3.7].

Thus, diffracted polychromatic neutrons can be successfully used in a PGAA facility. Even though the purity of the resulting thermal neutrons is inferior to that of a mirror-guided thermal beam, a higher flux and detection sensitivity have been achieved at considerably lower cost and effort. For example, quantification of sub-ppm boron content is feasible in a non-destructive manner within 30 min for a small sample of 0.1 g. Future upgrading of the facility to reduce the background is expected to enhance the performance further.

3.2. Characterization of prompt gamma neutron activation analysis at the Dalat research reactor

The principle of extraction of the neutron beam, and the design of the beam shutter, beam catcher, detector shielding, and gamma-ray spectrometer are briefly described below for the Prompt Gamma Neutron Activation Analysis (PGAA) facility at the Dalat reactor. Neutron flux, cadmium ratio, gamma dose rate and absolute efficiency are also quantified.

3.2.1. Experimental configuration

Neutron beam

The beam emerging from the reactor beam port consists mainly of fast and thermal neutrons and high-energy gamma rays. Peak to background ratio of the gamma-ray spectrum depends upon the background gamma radiation within the thermal neutron beam. Thermal neutrons are extracted from the beam port for PGAA by slowing down the fast neutrons to thermal energy and filtering out the high-energy gamma rays. Radiation beam port No. 4 was selected for the installation of the PGAA facility. The average neutron flux inside the reactor is of the order of 10¹³ n cm⁻² s⁻¹, from which a neutron flux level of 10¹² n cm⁻² s⁻¹ is required at the base of the collimator for PGAA. Graphite was selected as the moderator because of availability and the large diffusion length (40-cm thick, and placed 85 cm from the end side wall of the reactor). A 20-cm thick block of bismuth is used as a beam filter to minimize the high-energy gamma

radiation at the sample position and to reduce the need for additional shielding outside the biological shield. The beam aperture consists of two boron carbide sheets (each 3-mm thick) to give an aperture diameter of 25 mm. A hollow graphite block 15-cm thick separates the aperture from the moderator block in order to obtain a uniform neutron beam, and the outer diameter of the divergent beam collimator is 30 mm. Streaming of the radiation is eliminated by using bismuth and lead as beam stoppers that intercept all the radiation coming from the core of the reactor, gamma rays that arise from radiative capture of the neutrons, and scattered radiation from the sample and sample holder.

The beam shutter ensures the safe operation of the facility while positioning the sample. This shutter system consists of two parts:

- (a) first segment is made from borated paraffin, cadmium and boron carbide, and cadmium sheets, and is enclosed in aluminium casing - thermalized neutrons are attenuated and absorbed by the borated paraffin, cadmium and boron carbide sheets;
- (b) second part consists of 15-cm thick shutter made from lead bricks and boron carbide sheets, and enclosed in a steel casing.

The shutter is mounted on a trolley, and is moved into position by means of an overhead crane. The beam catcher is fabricated from borated paraffin, lead, boron carbide and steel, while an enclosure of concrete blocks provides additional shielding from the scattered gamma rays and neutron radiation. Fig. 3.4 shows the layout of the PGAA facility.

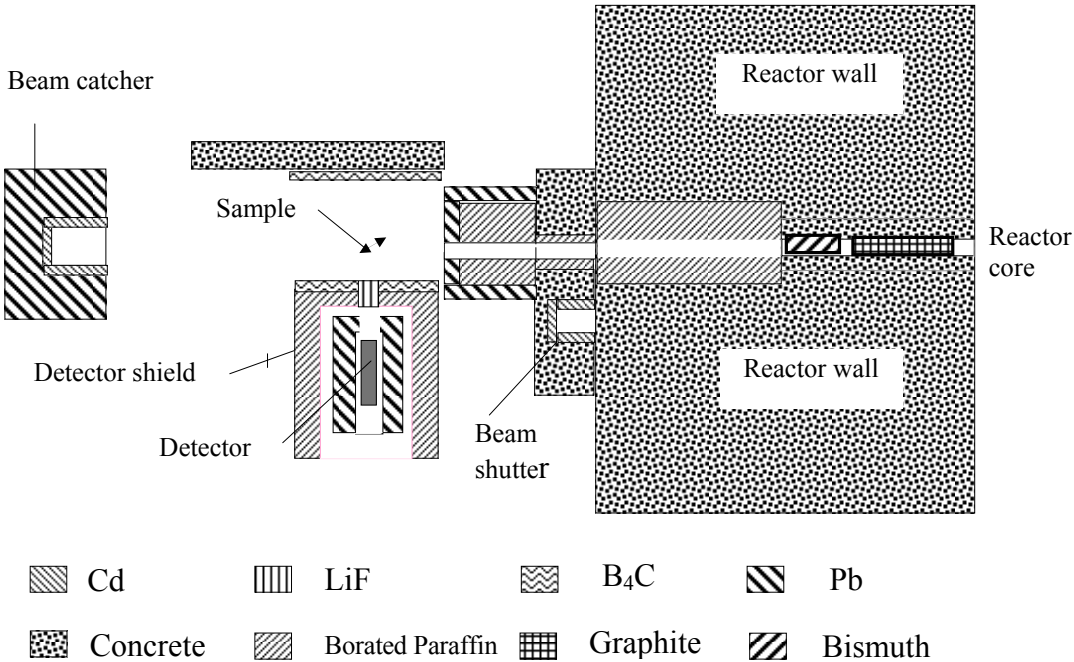

FIG.3.4 Configuration of PGAA facility at DNRI.

Detector shield and sample arrangement

90 cm³ horizontal HPGe detector manufactured by Inter-technique is used to count the prompt gamma rays (resolution of 2.5 keV at 1332 keV). The MCA has been calibrated from 0.121 to 8 MeV by means of the delayed gamma rays from ¹⁵²Eu and prompt gamma rays from ³⁵Cl(n, γ) and ¹⁴N(n, γ), using the energies and intensities recommended by Molnár *et al.* [3.8].

Samples are sealed in a film of 25- μ m thick fluorinated ethylenepropylene resin (FEP), and placed on the sample holder using 0.3-mm diameter PTFE string. The spectrometer system is directly shielded from the neutrons by a layer of 3-mm thick boron carbide, and on all sides by 10-cm borated paraffin. A 10-cm layer of lead is placed within the borated paraffin to protect the detector from undesired gamma rays that originate from the filtered neutron beam or neutron-capture reactions on the shielding materials (Fig. 3.4). The prompt gamma rays are detected through a window of Li₂CO₃ (32-mm diameter) located in the upper lead layer.

3.2.2. Characteristics of the system

Neutron flux, cadmium ratio and gamma dose rate

The beam position was determined by neutron radiography, and the neutron flux and flux distribution were measured by means of activated Au foils. The cadmium ratio was also determined by activating Au foils with and without a cadmium cover. Neutron flux and cadmium ratio are 2.1×10^7 n cm⁻² s⁻¹ and 21, respectively. Flux variations at the sample position during one reactor operation cycle of 100 hours were measured every 5 hours by means of 0.025-mm thick Au foils, and found to be 1.2%. The gamma dose rate at the sample position was determined by TLD to be 200 mR h⁻¹.

Efficiency calibration

Efficiency measurements have been described by many authors: the full-energy peak efficiency curve is divided into three energy regions of 100 to 658 keV, 447 to 2754 keV and

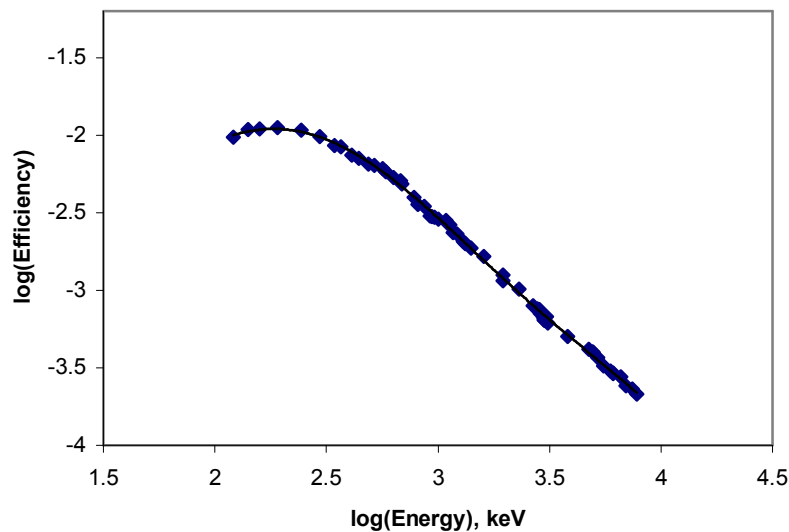

FIG. 3.5 Absolute efficiency curve.

1262 to 10829 keV. Gamma-ray sources of ^{24}Na , ^{54}Mn , ^{57}Co , ^{60}Co , ^{65}Zn , ^{88}Y , ^{137}Cs , ^{152}Eu and ^{241}Am were used for the absolute efficiency calibration from 100 to 2754 keV (calibrant emission probabilities from all of these sources have been recommended in IAEA-TECDOC 619 [3.9]). Prompt gamma rays from the $^{14}\text{N}(n, \gamma)$, $\text{Cl}(n, \gamma)$ and $\text{Ti}(n, \gamma)$ reactions cover a wide energy span from 0.5 to 10.829 MeV, and are sufficiently well-spaced to cover the efficiency curve from the low- to high-energy region; their intensity values (I_γ) are accurately defined in Proc. 4th Int. Symp. Neutron-capture Gamma-ray Spectroscopy and Related Topics, 1981. The resulting absolute efficiency curve is shown in Fig. 3.5.

3.3. NIST PGAA

The National Institute of Standards and Technology (NIST) Center for Neutron Research (NCNR) is centred on 20-MW research reactor that is cooled and moderated by D_2O [3.10]. This reactor operates on a seven-week cycle, with about 38 days of continuous operation between refuelling. Among the experimental facilities are two instruments for prompt gamma activation analysis (PGAA).

The thermal-neutron system was developed jointly by the University of Maryland and NIST, and has been in regular operation since 1978 [3.11, 3.12]. A vertical collimator extends 7 m down from the top of the reactor to the reactor midplane, with an external beam tube, beam stop and Ge detector with Compton suppressor; a 5-cm sapphire filter was added recently to reduce the background from fast neutrons and gamma rays. With the filter, the neutron fluence rate is $3.0 \times 10^8 \text{ n cm}^{-2} \text{ s}^{-1}$ and the cadmium ratio is 160. All components of the system outside the reactor have recently been replaced, with a large reduction in the background for H, B, C and N [3.13]. Furthermore, the titanium sensitivity for the capture line at 1382 keV is 1120 counts $\text{s}^{-1} \text{ g}^{-1}$ in the current configuration (detector efficiency of 40% when located about 45 cm from the irradiated sample).

A second system has been developed for cold-neutron prompt gamma-ray activation analysis (CPGAA), and has been operational since December 1990 [3.14]. Significant modifications have been made to this system [3.15]: CPGAA spectrometer is located 41 m from the liquid-hydrogen cold-neutron source at the end of the lower half of neutron guide NG7. Neutrons are filtered through 127-mm Be and 203-mm single-crystal Bi (both at 77K), before emerging through a 0.25-mm thick Mg-alloy window. The upper half of this neutron beam continues past the prompt gamma-ray station to a 30-m small-angle neutron scattering (SANS) instrument. Walls of 30-cm thick steel shot surround the guide tube, and a shutter composed of ^6Li -enriched glass can be opened to admit neutrons to the prompt gamma-ray station [3.16]. The neutron beam is collimated to 20 mm or smaller, as required, by apertures of ^6Li glass located upstream from the sample, and unused neutrons are absorbed by a fixed beam stop of ^6Li glass. Samples can be irradiated in air, or within a 120-mm cubical magnesium-alloy box that can be evacuated or purged with helium. The CPGAA spectrometer is shown in Fig. 3.6, with the detectors in position.

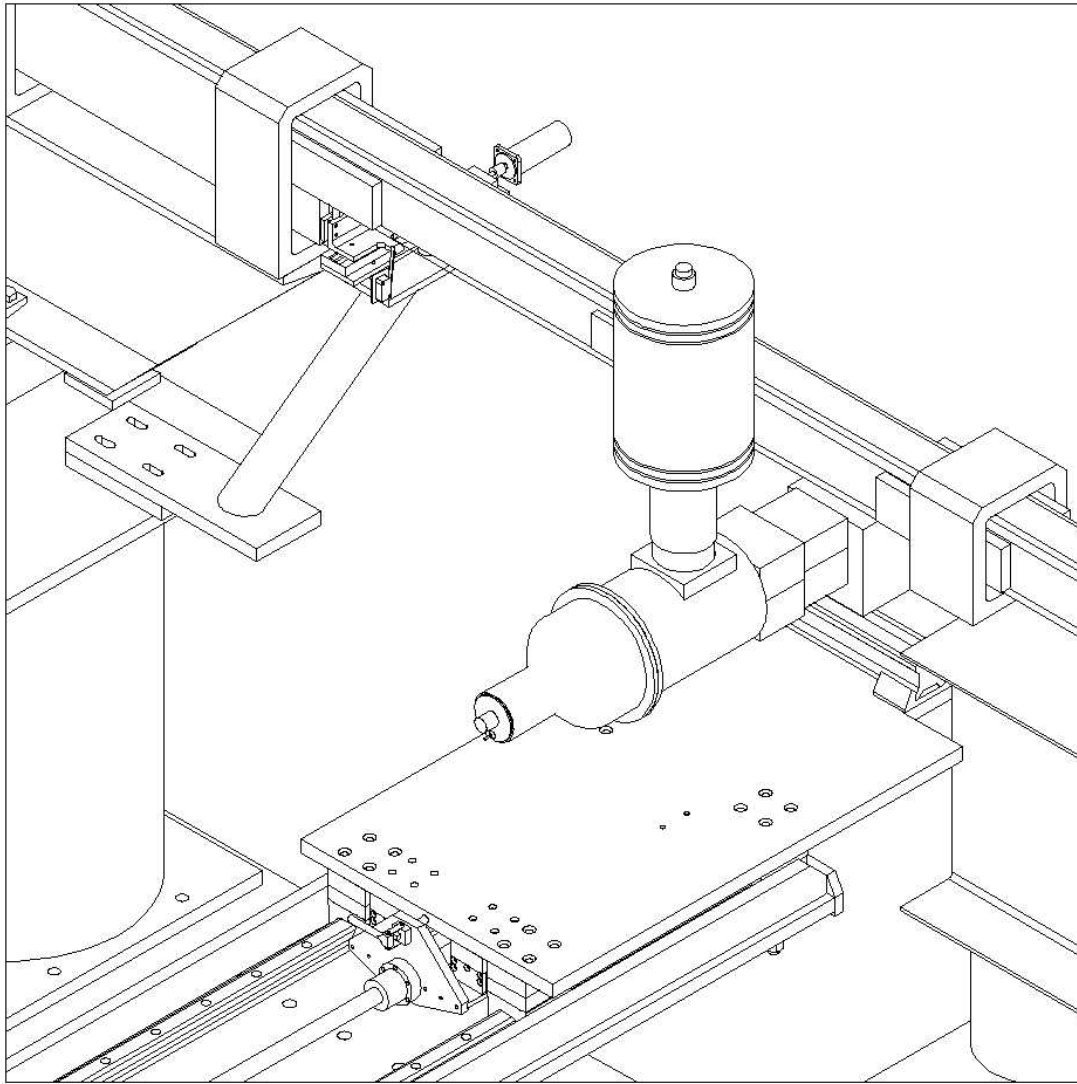

FIG.3.6 Isometric view of detectors in position with shielding removed.

The sample position is hidden by the gamma-ray collimator (rectilinear block in front of the horizontal BGO Compton detector), and the plate carrying the final neutron collimator, sample support, detectors and associated shielding is movable on the rails perpendicular to the neutron beam.

Prompt gamma rays are measured by a high-purity germanium detector (35% relative efficiency, 1.7 keV resolution) positioned vertically inside a horizontal bismuth germanate (BGO) Compton suppression detector at a distance of 35 cm from the sample. The detectors and their shielding are located on an aluminium plate carried on rails perpendicular to the neutron guide. Both the sample holder and neutron collimator are mounted on the same plate at a fixed position in front of the detector. Exchangeable lead apertures of different sizes placed between the detector and the sample allow variable collimation of the gamma-ray signal in order to balance detector efficiency with the field of view. A third-generation cold-neutron source was installed in early 2002 to give a thermal equivalent neutron fluence rate (reaction rate per atom divided by the 2200 m s^{-1} cross section) at the sample position of $9.5 \times 10^8 \text{ n cm}^{-2} \text{ s}^{-1}$, and titanium sensitivity of $7700 \text{ counts s}^{-1} \text{ g}^{-1}$ at 1382 keV.

Spectra up to 11 MeV can be measured in both the thermal- and cold-neutron PGAA system, using a digital signal processor on the cold-neutron system with Compton suppression electronics and Ethernet 16384-channel pulse height analyzers. Data reduction and spectral manipulation are accomplished by means of standard Canberra nuclear data software, the

HYPERMET program [3.4, 3.17], and an interactive algorithm SUM written at NIST [3.18].

Cold neutrons gain energy by scattering in hydrogenous samples at room temperature, and therefore the cross section for absorption depends on the sample temperature [3.19]. The thermal PGAA system is preferred for the analysis of materials such as biological tissues and foods, while the greater sensitivity and lower hydrogen background make the cold-neutron system advantageous for small samples and low concentrations.

3.4. Neutron capture gamma-ray facilities at the Budapest research reactor

The Budapest research reactor is a light-water moderated and light-water cooled reactor operating at 10 MW thermal power. Three neutron guides serve the external neutron beam facilities, and a liquid-hydrogen cold source was commissioned in early 2001.

The thermal-neutron prompt gamma activation analysis (PGAA) facility has been rebuilt, and includes a neutron-induced prompt gamma-ray spectrometer (NIPS) for a variety of experiments involving nuclear reaction-induced prompt and delayed gamma rays (including γ - γ -coincidences) [3.20-3.22]. A pneumatic beam shutter at the end of the guide tube allows the neutrons to enter the 3-m long evacuated aluminium tube that extends across the experimental area ($3 \times 5 \text{ m}^2$) to the beam stop at the rear wall of the guide hall (Fig. 3.7). This neutron beam can be divided into two separate beams of smaller diameter by appropriate collimation: the upper beam is used for PGAA measurements, while the lower beam is directed to the NIPS station.

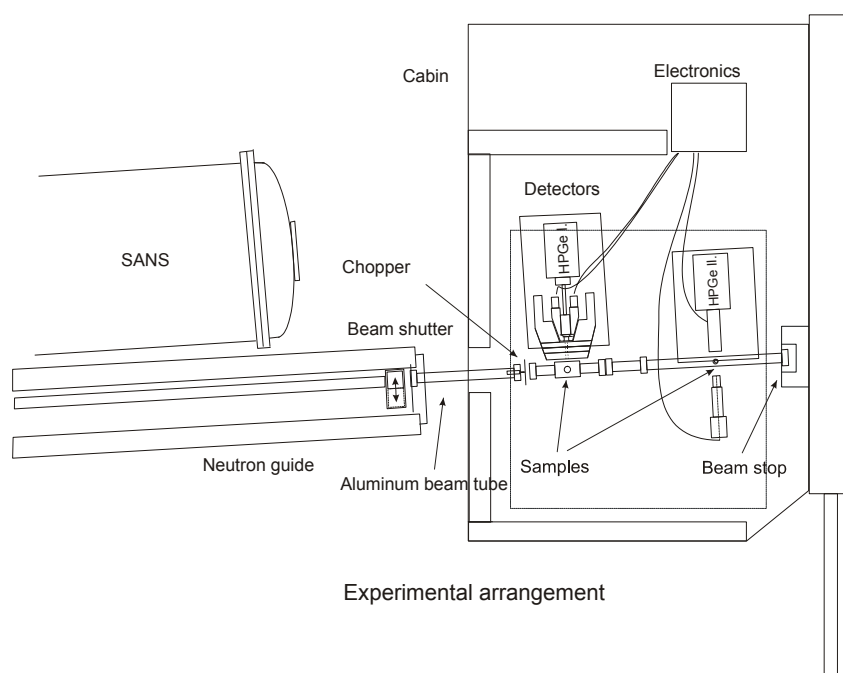

FIG. 3.7 PGAA-NIPS experimental area [3.20].

The PGAA target chamber is located at a distance of 1.5 m from the end of the guide tube, and targets are suspended on a thin aluminium frame by fine Teflon strings. Vacuo, ^4He or other gaseous atmospheres can be maintained inside the sample box to decrease the

background radiation induced by the neutrons. Furthermore, a neutron absorber layer can be placed in the horizontal plane to prevent scattering from the lower beam to the PGAA sample.

NIPS is positioned a further 1 m from the PGAA station, and is shielded with lead bricks to minimize the background radiation that originates from other measurements. The aluminium tubing and NIPS chamber are sufficiently narrow for several detectors to be placed close to the irradiated sample.

All three sections of aluminium tube can be easily removed if necessary, so that samples larger than the target chamber can be studied. A beam chopper is also provided for specific experimental investigations.

3.4.1. *Beam characteristics*

The thermal-equivalent neutron flux achieved at the old PGAA facility was $2 \times 10^6 \text{ n cm}^{-2} \text{ s}^{-1}$ [3.22]; fluxes at the sample positions of the new cold-neutron PGAA and NIPS facilities are 5×10^7 and $3 \times 10^7 \text{ n cm}^{-2} \text{ s}^{-1}$, respectively [3.20]. Both beams are individually collimated to give a cross section of 2×2 or $1 \times 1 \text{ cm}^2$. The neutron flux profile at the PGAA sample position is shown in Fig. 3.8

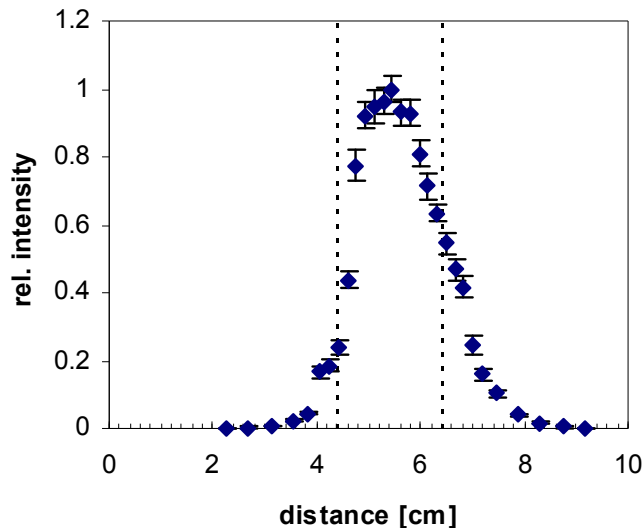

FIG. 3.8 Neutron flux profile at the sample position of the PGAA facility [3.21].

3.4.2. *PGAA instrumentation*

An n-type high-purity germanium (HPGe) detector with closed-end coaxial geometry is normally used in the PGAA facility, along with a BGO-scintillator guard detector annulus surrounded by 10-cm thick lead shielding [3.21, 3.22]. This complete system is positioned on a movable table. By removing the three lead disks in front of the detector, the HPGe detector can be placed 12 cm from the target, and as close as 3 cm by simply using the bare detector. The BGO annulus and catchers around the HPGe detect most of the scattered gamma photons. Connecting the HPGe and BGO in anticoincidence mode results in the accumulation of Compton-suppressed spectra.

Table 3.3 Main specifications of PGAA facility, Budapest research reactor [3.20].

Beam tube	NV1 guide, end position
Distance from guide end	1.5 m
Beam cross section	$1 \times 1 \text{ cm}^2$ or $2 \times 2 \text{ cm}^2$
Thermal-equivalent flux at target	$\approx 5 \times 10^7 \text{ cm}^{-2} \text{ s}^{-1}$
Vacuum in target chamber (optional)	$\approx 1 \text{ mbar}$
Target chamber Al-window thickness	0.5 mm
Form of target at room temperature	solid/powder/liquid/gas (pressurized chamber)
Target packing at atmospheric pressure	sealed FEP Teflon bag or vial
Activity of target after irradiation	negligible
Largest target dimensions	$4 \times 4 \times 10 \text{ cm}^3$
γ -ray detector	n-type coaxial HPGe with BGO shield
Distance from target to detector window	23.5 cm
HPGe window	0.5 mm Al
Relative efficiency	25% at 1332 keV (^{60}Co)
FWHM	1.8 keV at 1332 keV (^{60}Co)
Compton suppression enhancement	≈ 5 (1332 keV) to ≈ 40 (7000 keV)

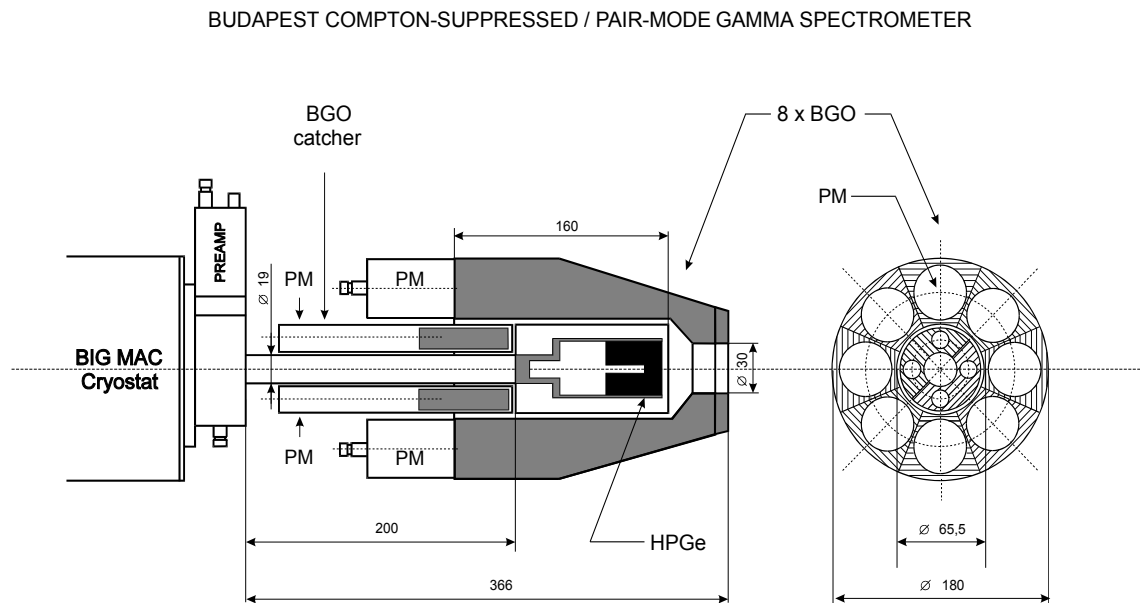

FIG. 3.9 Cross section of HPGe-BGO gamma-ray spectrometer [3.22].

With appropriate electronic gating, the HPGe-BGO gamma-ray spectrometer can also be used in annihilation-pair mode to simplify the spectra at high energies [3.22]. A 16k PC-based multichannel analyzer collects the resulting data. The HPGe-BGO detector assembly is shown

in Fig. 3.9, and the operational characteristics of the PGAA system are listed in Table 3.3. A Compton-suppression ratio of about 5 can be achieved for the 1332 keV gamma-ray emission of ^{60}Co (although this ratio is much larger for higher-energy gamma rays, as can be seen in Fig. 3.10).

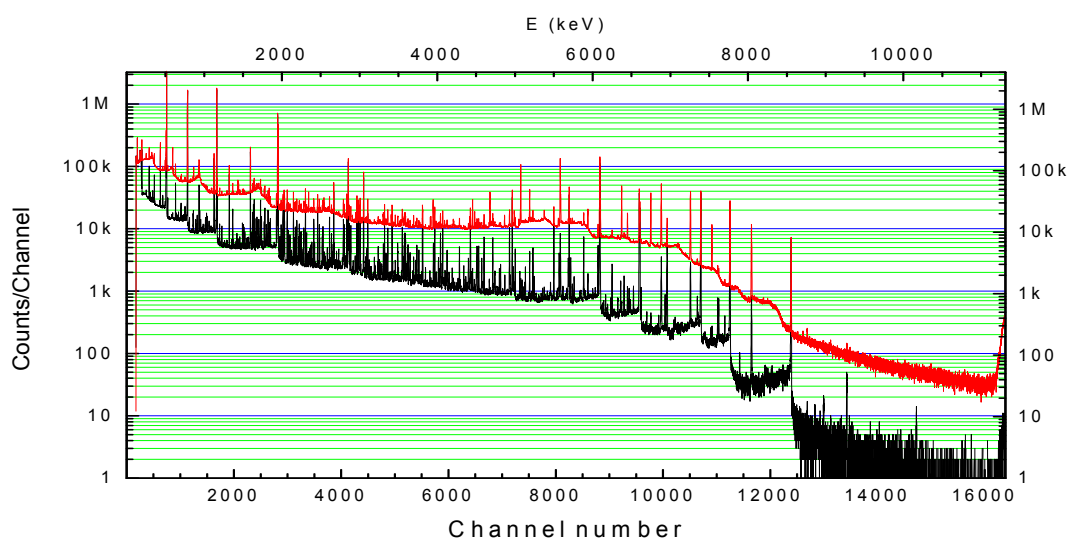

FIG. 3.10 Normal (upper) and Compton-suppressed (lower) spectra of CCl_4 sample.

3.4.3. Detection efficiency and system non-linearity

The energy and intensity calibration of the γ -ray spectrometer system is important for both nuclear spectroscopic and analytical experiments. However, this essential procedure becomes problematic when the energy of interest is greater than the highest gamma-ray energy of the ^{56}Co calibrant source. The counting efficiency has been accurately determined over the energy range of 50 keV to 10 MeV using several multi γ -ray sources and (n, γ) reactions in order to avoid this difficulty. The accuracy of the efficiency function is better than 1% from 500 keV to 6 MeV [3.22]. Fig. 3.11 shows the absolute full-energy peak efficiency for a target-to-detector distance of 23.5 cm, with the single- and double-escape peak efficiencies also included.

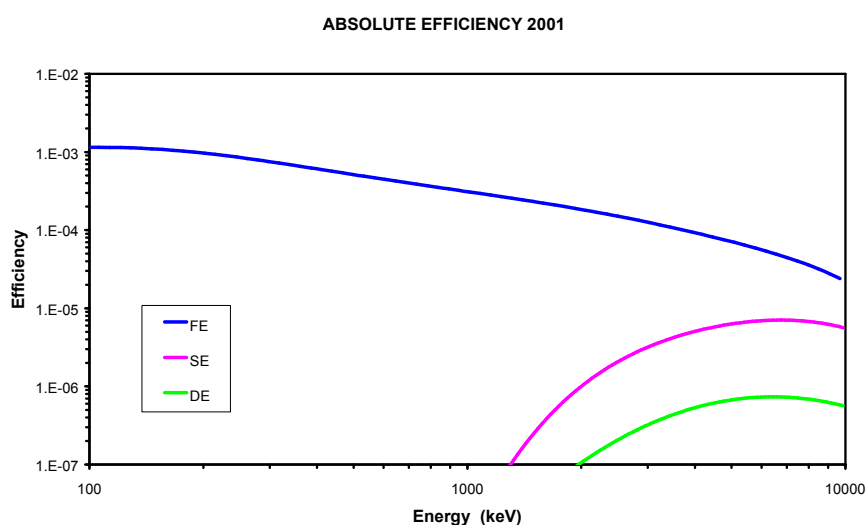

FIG. 3.11 Efficiency of PGAA spectrometer in Compton-suppressed mode (FE–full energy; SE–single escape; DE–double escape peak).

When constructing the non-linear energy function, long-term instabilities of the system may result in peak shifts and create inconsistencies between independent measurements. Therefore, a non-linear calibration procedure has been introduced to overcome this problem that uses radioactive sources and capture gamma rays with well-known energies [3.6]. When the non-linear function is combined with the normal linear energy calibration for strong gamma-ray peaks, an energy precision of between 0.01 and 0.1 keV can be achieved depending on the statistics. The non-linearity functions are regularly determined at the beginning of each period of reactor operation.

3.4.4. Data acquisition and analysis

A Canberra S100-type single-input, PC-based multichannel analyzer (MCA) has been used to collect PGAA spectra. However, a digital spectrum analyser will soon be installed to achieve a much higher input rate without any substantial deterioration in the spectral resolution.

Gamma-ray spectra from neutron capture are extremely complex, and therefore a high-quality fitting code has been developed for the data analysis [3.23]. HYPERMET-PC is an interactive, non-linear fitting code that evolved from the spectrum evaluation program HYPERMET. The PC version has user-friendly graphics and a database to store the fitted regions, as well as quality assurance, calibration and nuclide identification modules. Peak energies and intensities that result from the fitting process can be corrected within the program for non-linearity and detector efficiency, respectively. Element identification on the basis of peak energies is also possible with the help of the built-in library.

3.5. Prompt gamma-ray neutron activation analysis at Bhabha Atomic Research Centre (BARC)

Initial PGAA studies at BARC were carried out using a guided-beam facility, and subsequent improvements included the installation of a reflected beam. A dedicated beam line is currently being developed. Brief descriptions of these systems are given in below.

3.5.1. PGAA systems

The thermal guided-beam facility in the 100 MW Dhruva reactor at BARC, Trombay has been used for PGAA. A beam tube was used to guide and transport the neutrons about 30 m away from the reactor core to a temporary experimental facility (beam of cross section $2.5 \times 10 \text{ cm}^2$). 1-cm thick boron carbide sheet minimized the neutrons scattered towards the detector, except when boron was contained within the sample for analysis. The γ -ray detector was located about 40 cm from the irradiated sample, and was provided with 30-cm thick lead shielding to reduce the background radiation. A lead collimator (3 cm diameter and 30 cm length) was placed in front of the detector to control the gamma rays emitted from the sample. The layout of this PGAA system is shown in Fig. 3.12.

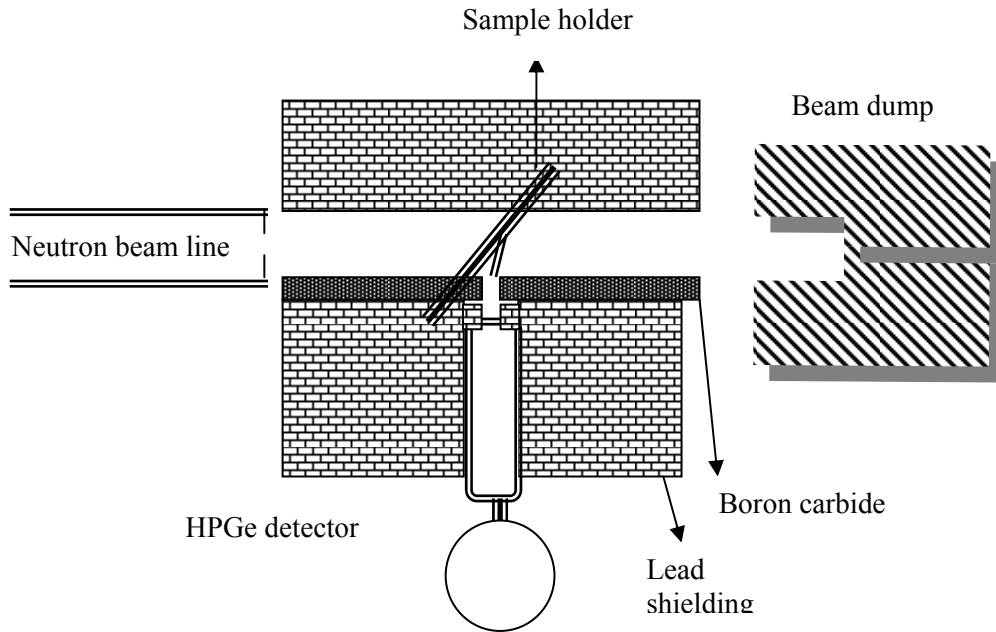

FIG. 3.12 PGAA arrangement at BARC.

The effective thermal neutron flux at the sample irradiation position has been measured by means of In foils, while the cadmium ratio method was used to determine the sub-cadmium to epithermal flux ratio. An In foil (110 mg cm^{-2}) was irradiated with and without a covering of cadmium (0.8-mm thick), followed by off-line counting of $^{116\text{m}}\text{In}$ by means of 15% relative efficiency HPGe detector coupled to a 4k multichannel analyzer (MCA). The sub-cadmium to epithermal neutron flux ratio was found to 3.45×10^4 , indicating that more than 99.99% of the neutron beam consisted of thermal neutrons at the irradiation position. $Q_o(I_0/\sigma_0)$ value of 16.8 was derived from $^{116\text{m}}\text{In}$ gamma rays (E_γ of 1097 and 1293 keV), and used to estimate a total neutron flux of $(1.4 \pm 0.1) \times 10^7 \text{ n cm}^{-2} \text{ s}^{-1}$ [3.24]. The In foil was estimated to attenuate the beam by as much as 8%, which affected the cadmium ratio. However, this effect does not impact on the k_0 values or elemental analyses based on this method.

3.5.2. Sample irradiation and data acquisition

Samples weighing between 100 and 500 mg were wrapped in thin Teflon tape and placed at 90° with respect to the beam direction. Care was taken to ensure that the sample size was significantly less than the beam dimensions. 22% relative efficiency HPGe detector connected to a PC-based 8k MCA was used to assay the prompt gamma rays, with a resolution of 2.4 keV at 1332 keV.

3.5.3. Energy calibration and peak area analysis

The MCA has been calibrated from 0.1 to 8.5 MeV by means of the delayed gamma rays of ^{152}Eu and ^{60}Co , and prompt gamma rays of ^{36}Cl and ^{49}Ti . Non-linearity over this energy range was not significant, and therefore a second-order polynomial was used for the energy calibration. The Lone et al. compilation of capture gamma rays was used to identify the prompt gamma-ray emissions of the different elements [3.25].

Photopeak areas in the gamma-ray spectra were determined using the PHAST-2.6 code developed in Electronics Division, BARC [3.26]. This software can be used to derive energy

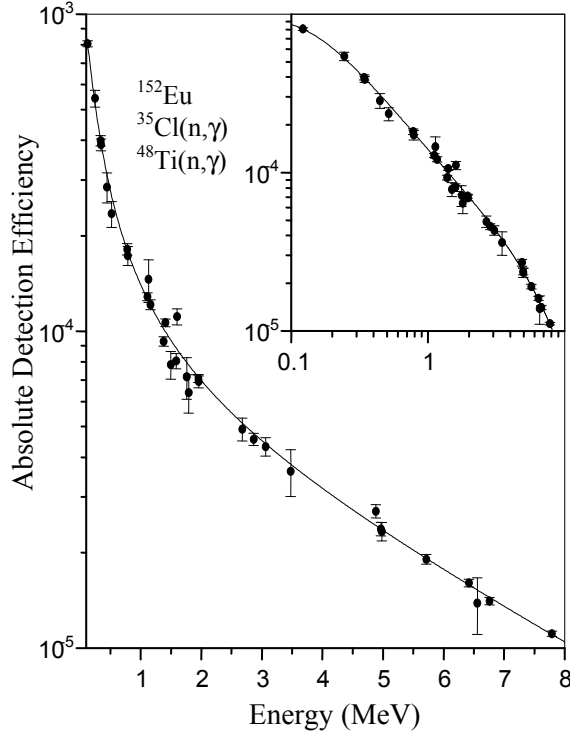

FIG. 3.13 Absolute detection efficiency of PGAA system at BARC.

calibrations and determine spectral shape parameters. A second-order polynomial was used to calibrate the width (FWHM) of the photopeaks, and the measured FWHM and shape parameters as functions of energy were subsequently used to identify multiplets and undertake their deconvolution.

3.5.4. Efficiency calibration

Delayed gamma rays from ¹⁵²Eu and prompt gamma rays from ³⁶Cl and ⁴⁹Ti were used for absolute/relative efficiency calibrations of the detector over a wide energy range from 100 keV to 10 MeV. The absolute gamma-ray abundances of ³⁶Cl and ⁴⁹Ti were obtained from the literature [3.9, 3.27]. Ammonium chloride packed in Teflon was irradiated for about 12 hours, and capture gamma-ray spectra were accumulated. Absolute full-energy peak efficiencies were determined for the lower energy region (i.e., up to 1500 keV) using the gamma-ray spectrum of ¹⁵²Eu, and the relative efficiency plot from 0.5 to 8 MeV was obtained from the prompt gamma-ray spectra of ³⁶Cl and ⁴⁹Ti. Relative efficiencies were converted to absolute values using the overlap with equivalent ¹⁵²Eu data.

Efficiencies as a function of gamma-ray energy (E_γ) were fitted to a fifth-order polynomial using Equation (1):

$$(\ln \varepsilon)_{E_\gamma} = k_j + \sum_{i=0}^5 a_i (\ln E_\gamma)^i \quad (1)$$

where a_i are the coefficients of the polynomial, and k_j is the normalization constant for the j^{th} gamma-ray emitting nuclide used in the efficiency calibration. The number of free parameters used to fit the efficiency data are $(6 + (n - 1))$, where n is the number of radionuclides whose gamma-ray emissions have been used in the fitting procedure. A standard non-linear least squares program was

used in which the peak areas of the gamma rays from each specific nuclide are fitted with a particular constant k_j so that the relative efficiency curves from different radionuclides are normalized with respect to the absolute efficiency determined from ^{152}Eu . The efficiency of the PGAA system at BARC is shown in Fig. 3.13 (insert shows the efficiency on logarithm scale).

3.5.5. New beam facility at Dhruva reactor

Another PGAA system has been established at the Dhruva reactor (BARC), using a reflected neutron beam that is normally applied to neutron diffraction experiments. The tangential beam of neutrons is reflected by a graphite crystal towards the PGAA experimental facility (neutron energy of 0.05 eV, and composed mainly of first-order reflection). Neutron beam characteristics have been determined in terms of dimensions, homogeneity and thermal equivalent flux. A Gd-loaded neutron radiographic film was held in the beam path to measure a neutron beam area of $2.5 \times 3.5 \text{ cm}^2$. The neutron flux profile was obtained by irradiating Au foil ($40 \text{ mm} \times 40 \text{ mm}$) for 48 hours in the beam, cutting the foil into 64 squares ($5 \text{ mm} \times 5 \text{ mm}$), and then measuring the activity.

Separate shielding has been placed in front of the detector: $8 \text{ cm} \times 8 \text{ cm} \times 30 \text{ cm}$ collimator was located inside a lead shield of $30 \text{ cm} \times 30 \text{ cm} \times 60 \text{ cm}$. Graded shielding was also used around the detector. Samples are held in quartz containers placed in front of the collimator and within the path of the neutron beam. Compared to the earlier PGAA system, the background in the newer facility has been reduced by a factor of two. The same data acquisition system is used as previously, and the procedures followed for the energy and efficiency calibrations are identical. Fig. 3.14 shows the efficiency calibration of the new facility presented as both logarithm and linear scales.

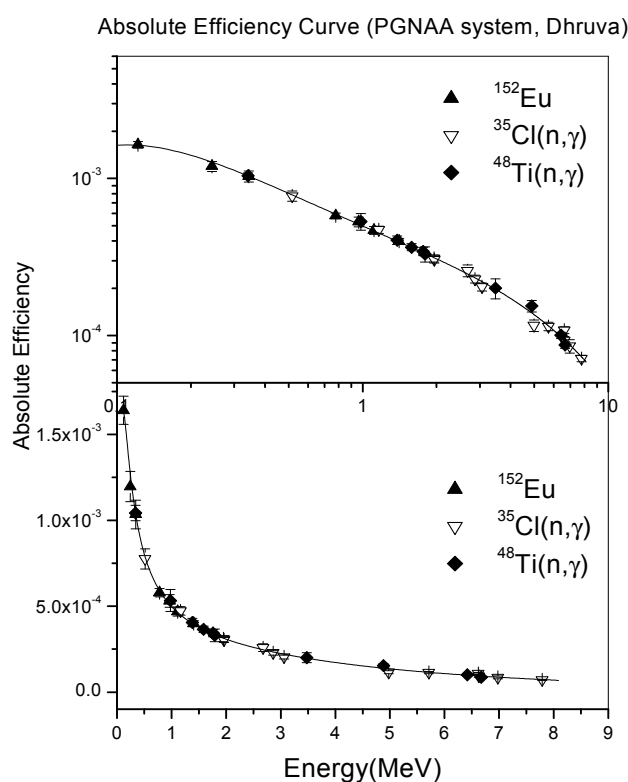

FIG. 3.14 Detection efficiency as a function of energy, PGAA system, BARC.

3.6. Summary of experimental facilities

The most important performance characteristics of any PGAA facility are the thermal equivalent neutron flux and the associated neutron spectrum, gamma-ray detection sensitivity, and achieving low background. Other essential features included the method and quality of the calibrations and spectral analyses. The main characteristics of the facilities associated with the present CRP are summarized in Table 3.4. These comparative data show that the development of an excellent performance feature for a particular facility is usually achieved at the expense and degradation of other features. While improved characteristics can be achieved in various ways, the best performance is often achieved by considering conditions at the site and tailoring the facility design accordingly, and by improving operational characteristics gradually during the course of the various work programmes.

Table 3.4 Main characteristics of the PGAA facilities in the CRP.

Facility	Characteristics
SNU-KAERI	Thermal beam extraction: diffraction (pyrolytic graphite) Beam flux: 8.2×10^7 n cm ⁻² s ⁻¹ (thermal equivalent) Beam size: 2×2 cm ² Cd-ratio: 266 (for gold) Effective temperature: 269K Ti (1382 keV) sensitivity: 2020 counts s ⁻¹ g ⁻¹ Detection system: single HPGe with pulse processing system Total background counting rate: 3000 counts s ⁻¹
Dalat Research Reactor	Thermal beam extraction: moderation (graphite) and filtering (Bi) Beam flux: 2.1×10^7 n cm ⁻² s ⁻¹ Beam size: 2.5 cm Cd-ratio: 21 (for gold) Detection system: single HPGe with pulse processing system
NIST (Thermal)	Thermal beam extraction: filtering (sapphire) Beam flux: 3.0×10^8 n cm ⁻² s ⁻¹ Cd-ratio: 160 Effective temperature: 300K Ti (1382 keV) sensitivity: 890 counts s ⁻¹ g ⁻¹ Detection system: HPGe and Compton suppression electronics
(Cold)	Cold beam extraction: filtering (Be, Bi) and mirror guide Beam flux: 9.5×10^8 n cm ⁻² s ⁻¹ (thermal equivalent) Beam size: 2 cm or smaller Effective temperature: 14K Ti (1382 keV) sensitivity: 7700 counts s ⁻¹ g ⁻¹ Detection system: HPGe and Compton suppression electronics
Budapest Research Reactor	Cold beam extraction: mirror guide Beam flux: 5×10^7 n cm ⁻² s ⁻¹ (thermal equivalent) Beam size: 1×1 cm ² or 2×2 cm ² Effective temperature: ~ 60K Ti (1382 keV) sensitivity: 750 counts s ⁻¹ g ⁻¹ Detection system: HPGe and Compton suppression electronics
BARC (Thermal 1)	Thermal beam extraction: mirror guide Beam flux: 1.4×10^7 n cm ⁻² s ⁻¹ (total) Beam size: 2.5×10 cm ² Cd-ratio: 3.4×10^4 (for indium) Detection system: single HPGe with pulse processing system
(Thermal 2)	Thermal beam extraction: diffraction (graphite) Beam flux: 1.6×10^6 n cm ⁻² s ⁻¹ (thermal equivalent) Beam size: 2.5×3.5 cm ² Detection system: single HPGe with pulse processing system

3.7. Experiments

The largest amount of new PGAA data has come from the Institute of Isotope and Surface Chemistry, Budapest, Hungary. Neutron capture reactions on all naturally-occurring elements except the four noble gases have been studied by means of the guided thermal-neutron beam PGAA facility at the Budapest Research Reactor (i.e., 79 elements from H to U). The $^{10}\text{B}(n, \alpha\gamma)$ reaction on natural boron has also been measured. These results are described below.

A thermal guided beam was used for PGAA experiments at the Bhabha Atomic Research Centre (BARC), India. Activities concentrated on the experimental determination of prompt k_0 -factors with respect to the 1951-keV gamma-ray emission from the $^{35}\text{Cl}(n, \gamma)^{36}\text{Cl}$ reaction using a mixture of ammonium chloride and other stoichiometric compounds [3,28, 3.29]. The emission probabilities of capture gamma rays from ^{60}Co were also determined [3.29, 3.30].

The Seoul National University-KAERI PGAA system was used in Korea to measure the prompt k_0 -factors for the major non- $1/v$ nuclides, and to determine the corresponding effective g -factors for their polychromatic diffracted neutron beam [3.7].

Vietnam Atomic Energy Commission has supported Dalat measurements of prompt k_0 -factors for a number of elements with respect to the 1951-keV gamma-ray emission from chlorine, using a filtered thermal neutron beam [3.31]. The reliability of these k_0 -factors has been tested on all facilities for a number of applications.

The Budapest group has measured partial cross sections for the elements. As the other CRP participants have measured only k_0 -factors with respect to the 1951-keV chlorine line, comparison with the adopted set and the new Budapest data is only possible for the similar inferred k_0 -factors. Available data are compared in Table 3.5 with the adopted set from the CRP and the new Budapest data [3.32]. Data from the NIST-University of Maryland thermal-beam facility [3.33], as well as recent data obtained in thermal and cold guided beams at the Japan Atomic Energy Research Institute (JAERI) [3.34, 3.35], are also included in order to assess the possible dependence on neutron beam characteristics.

The data in Table 3.5 show that the agreement is generally good for $1/v$ nuclides at the quoted uncertainty level. Furthermore, it is especially gratifying to observe that the very precise JAERI data corroborate the adopted values, as do the new Budapest data. Moreover, the cold neutron data from JAERI agree well with similar data from NIST and with the thermal data, supporting the $1/v$ form of the cross sections. The only exceptions are the well-known cases discussed in Chapter 2: ^{113}Cd , ^{149}Sm and $^{155, 157}\text{Gd}$ for which the g -factor deviates strongly from unity.

Table 3.5 Comparison of library $k_{0,C1}$ -factors with other measurements for the most prominent γ rays of selected elements.

Z	Target Isotope	E(d e)	Adopted	Dalat thermal beam [3.31]	BARC thermal guide [3.28]	SNU diffraction beam [3.7]	NIST-thermal beam [3.33]	JAERI thermal guide [3.34, 3.35]	NIST cold guide [3.33]	JAERI cold guide [3.34, 3.35]	Budapest thermal guide [3.32]
1	1-H	2223.25	1.848(11)		1.800(16)		2.00(10)	1.80(6)	2.05(11)	1.86(6)	1.803(10)
3	7-Li	2032.30(4)	0.0307(8)	0.0230(5)*							
5	10-B	477.595(3)	369.5(23)		312(22)			371(31)		380(32)	360(3)
6	12-C	1261.765(9)	0.000579(15)	0.00041(1)*				0.000573(5)		0.000551(6)	0.000546(9)
	12-C	4945.301(3)	0.001218(25)					0.00124(3)		0.001160(17)	0.001192(13)
7	14-N	1884.821(16)	0.00588(8)	0.00567(11)				0.005800(13)		0.005890(18)	0.00569(4)
11	23-Na	472.202(9)	0.1165(11)				0.105(4)	0.11600(41)	0.105(4)	0.1160(25)	0.1181(13)
12	25-Mg	585.00(3)	0.0072(3)				0.0065(2)		0.0064(3)		
13	27-Al	1778.92(3)	0.0482(10)				0.0467(18)	0.0440(4)	0.0463(21)	0.0433(14)	0.0472(9)
14	28-Si	2092.902(18)	0.00660(13)	0.00603(11)							
	28-Si	3538.966(22)	0.0237(4)				0.0214(7)	0.02180(10)	0.0216(9)	0.02110(11)	0.0231(5)
15	31-P	636.663(21)	0.0056(3)					0.00572(9)		0.00570(9)	0.0055(3)
16	32-S	840.993(13)	0.0606(11)	0.0603(15)			0.0558(18)	0.0554(10)	0.0562(23)	0.0570(12)	0.0608(13)
17	35-Cl	786.3020(10)	0.540(3)		1.30(3)&		1.28(6)&	1.330(45)&	1.26(7)&	1.350(44)&	
	35-Cl	788.4280(10)	0.856(9)		1.30(3)&		1.28(6)&	1.330(45)&	1.26(7)&	1.350(44)&	
	35-Cl	1951.1400(20)	1	1	1	1		1		1	1
19	39-K	770.3050(20)	0.1294(18)		0.116(4)		0.126(4)	0.127(4)	0.122(5)	0.128(4)	0.127(3)
20	40-Ca	1942.67(3)	0.0492(10)		0.045(2)		0.0461(16)	0.047(2)	0.0459(19)	0.0464(16)	0.0463(14)
22	48-Ti	341.706(5)	0.215(3)		0.187(6)*			0.211(3)		0.2250(16)	
	48-Ti	1381.745(5)	0.606(15)	0.433(10)*	0.604(13)		0.582@	0.582(6)	0.591@	0.591(6)	0.591(7)
	48-Ti	1585.941(5)	0.0730(10)		0.056(3)*						
24	50-Cr	749.09(3)	0.0614(10)		0.065(8)			0.0562(20)		0.0601(25)	
	50-Cr	834.849(22)	0.149(3)		0.138(8)			0.141(5)		0.142(5)	0.145(2)
	50-Cr	7938.46(23)	0.0457(11)		0.048(3)						
25	55-Mn	314.398(20)	0.1488(22)					0.152(5)		0.149(8)	0.150(3)
26	56-Fe	352.347(12)	0.0274(3)				0.0253(9)	0.0273(10)	0.0248(10)	0.0269(11)	
	56-Fe	7631.136(14)	0.0654(13)					0.0568(24)*		0.0537(27)*	0.0676(14)

Table 3.5 Cont.

Z	Target Isotope	E(dE)	Adopted	Dalat thermal beam [3.31]	BARC thermal guide [3.28]	SNU diffraction beam [3.7]	NIST-thermal beam [3.33]	JAERI thermal guide [3.34, 3.35]	NIST cold guide [3.33]	JAERI cold guide [3.34, 3.35]	Budapest thermal guide [3.32]
27	59-Co	229.879(17)	0.682(8)		0.58(4)			0.67(2)		0.664(22)	0.702(8)
	59-Co	277.161(17)	0.643(8)		0.55(4)*			0.619(21)		0.615(21)	
	59-Co	555.972(13)	0.547(6)		0.46(3)*			0.516(18)	0.460(12)*	0.509(20)	
	59-Co	1515.720(25)	0.165(3)		0.186(6)*						
	59-Co	1830.800(25)	0.1616(24)		0.19(1)*						
	59-Co	6485.99(3)	0.220(6)		0.185(15)*						
	59-Co	7214.42(3)	0.131(3)		0.156(6)*						
28	58-Ni	464.978(12)	0.0804(10)				0.075(3)	0.081(3)	0.074(3)	0.0811(28)	0.0781(9)
29	63-Cu	278.250(14)	0.0787(14)		0.068(4)			0.077(3)		0.0762(25)	0.0831(9)
	63-Cu	384.45(5)	0.00617(13)		0.019(1)&			0.0174(7)&		0.0166(6)&	
	65-Cu	385.77(3)	0.01155(18)		0.019(1)&			0.0174(7)&		0.0166(6)&	
	63-Cu	7306.93(4)	0.0283(15)		0.0261(14)						
37	85-Rb	556.82(3)	0.00599(17)	0.00210(5)*							
38	87-Sr	898.055(11)	0.0449(8)					0.042(2)		0.0425(14)	0.0434(6)
	87-Sr	1836.067(21)	0.0658(12)								0.0634(7)
49	113-Cd [#]	558.32(3)	92.6(16)		41(2)*	90(6)	132(7)*	81(2)	66(4)*	61.5(1.5)*	90.7(11)
55	133-Cs	116.3740(20)	0.059(6)					0.172(6)&		0.172(6)&	
	133-Cs	116.612(4)	0.061(6)					0.172(6)&		0.172(6)&	
	133-Cs	307.015(4)	0.0612(13)					0.0692(25)*		0.0711(26)*	0.0546(7)*
56	138-Ba	627.29(5)	0.01200(25)		0.0106(3)			0.0111(4)		0.0108(4)	
	135-Ba	818.514(12)	0.00865(17)		0.012(2)*						
	137-Ba	1435.77(4)	0.0126(3)		0.011(1)			0.0118(4)		0.0118(4)	
62	149-Sm [#]	333.97(4)	178.4(24)	188(4)		172(14)	339(18)*	131(9)*	111(7)*	116(1)*	178(2)
63	151-Eu [#]	89.847(6)	52.7(11)			46(3)					
64	157-Gd [#]	181.931(4)	257(11)			277(15)	222(12)	255(3)	236(13)	214(1)*	267(6)
	155-Gd [#]	199.2130(10)	71.9(23)			68(5)					
	157-Gd [#]	944.174(10)	110.0(25)	162(3)							

Table 3.5 Cont

Z	Target Isotope	E(dE)	Adopted	Dalat thermal beam [3.31]	BARC thermal guide [3.28]	SNU diffraction beam [3.7]	NIST-thermal beam [3.33]	JAERI thermal guide [3.34, 3.35]	NIST cold guide [3.33]	JAERI cold guide [3.34, 3.35]	Budapest thermal guide [3.32]
	155-Gd [#]	1187.120(21)	12(4)		111(4) ^{&*}	105(6) ^{&*}					
	157-Gd [#]	1187.122(9)	51(3)		111(4) ^{&*}	105(6) ^{&*}					
73	181-Ta	402.623(3)	3.29(8)	0.156(3) [*]							
80	199-Hg	367.947(9)	7.00(15)		5.8(3)			7.11(26)		7.01(14)	6.82(12)
	199-Hg	1693.296(11)	1.57(5)		1.37(8)			1.41(5)		1.40(5)	
	199-Hg	5967.02(4)	1.74(4)								1.43(6) [*]
82	207-Pb	7367.78(7)	0.00370(8)					0.00338(6)		0.00329(3)	0.00361(8)

* Value deviates significantly from Adopted Value.

& Doublet line.

Non 1/ ν nuclide.

@ Normalizing transition - set equal to corresponding JAERI value.

REFERENCES

- [3.1] BYUN, S.H., SUN, G.M., CHOI, H.D., Development of a Prompt Gamma Activation Analysis Facility Using Diffracted Polychromatic Neutron Beam, *Nucl. Instrum. Meth. Phys. Res.* **A487** (2002) 521-529.
- [3.2] BYUN, S.H., SUN, G.M., CHOI, H.D., Beam Characteristics of Polychromatic Diffracted Neutrons Used for Prompt Gamma Activation Analysis, *J. Korean Nucl. Soc.* **34** (2002) 30-41.
- [3.3] BYUN, S.H., SUN, G.M., CHOI, H.D., Characterization of a Polychromatic Neutron Beam Diffracted by Pyrolytic Graphite Crystals, *Nucl. Instrum. Meth. Phys. Res.* **A490** (2002) 538-545.
- [3.4] PHILLIPS, G.W., MARLOW, K.W., Automatic Analysis of Gamma Ray Spectra from Germanium Detectors, *Nucl. Instrum. Meth.* **137** (1976) 525-536.
- [3.5] KIS, Z., FAZEKAS, B., ÖSTÖR, J., RÉVAY, Zs., BELGYA, T., MOLNÁR, G.L., KOLTAY, L., Comparison of Efficiency Functions for Ge Gamma-ray Detectors in a Wide Energy Range, *Nucl. Instrum. Meth. Phys. Res.* **A418** (1998) 374-386.
- [3.6] FAZEKAS, B., RÉVAY, Zs., ÖSTÖR, J., BELGYA, T., MOLNÁR, G., SIMONITS, A., A New Method for Determination of Gamma-ray Spectrometer Non-linearity, *Nucl. Instrum. Meth. Phys. Res.* **A422** (1999) 469-473.
- [3.7] SUN, G.M., BYUN, S.H., CHOI, H.D., Prompt k_0 -factors and Relative γ -Emission Intensities for the Strong Non-1/v Absorbers ^{113}Cd , ^{149}Sm , ^{151}Eu and $^{155,157}\text{Gd}$, *J. Radioanal. Nucl. Chem. Vol.* **256** (2003) 541-542
- [3.8] MOLNÁR, G.L., BELGYA, T., DABOLCZI, L., FAZEKAS, B., RÉVAY, Zs., VERES, Á., BIKIT, I., KIS, Z., ÖSTÖR, J., The New Prompt Gamma Activation Analysis Facility at Budapest, *J. Radioanal. Nucl. Chem.* **215** (1997) 111-115.
- [3.9] X-ray and Gamma-ray Standards for Detector Calibration, IAEA-TECDOC-619, International Atomic Energy Agency, Vienna, Austria, 1991.
- [3.10] PRASK, H.J., ROWE, J.M., RUSH, J.J., SCHRÖDER, I.G., The NIST Cold Neutron Research Facility, *J. Res. NIST* **98** (1993) 1-14.
- [3.11] FAILEY, M.P., ANDERSON, D.L., ZOLLER, W.H., GORDON, G.E., LINDSTROM, R.M., Neutron-capture Prompt γ -ray Activation Analysis for Multielement Determination in Complex Samples, *Anal. Chem.* **51** (1979) 2209-2221.
- [3.12] ANDERSON, D.L., FAILEY, M.P., ZOLLER, W.H., WALTERS, W.B., GORDON, G.E., LINDSTROM, R.M., Facility for Non-destructive Analysis for Major and Trace Elements Using Neutron-capture Gamma-ray Spectrometry, *J. Radioanal. Chem.* **63** (1981) 97-119.
- [3.13] MACKEY, E.A., ANDERSON, D.L., LAMAZE, G., LINDSTROM, R.M., LIPOSKY, P.J., Upgrade of the NIST Thermal Neutron Prompt-gamma-ray Activation Analysis Facility, *Trans. Am. Nucl. Soc.* **83** (2000) 487-488.
- [3.14] LINDSTROM, R.M., ZEISLER, R., VINCENT, D.H., GREENBERG, R.R., STONE, C.A., MACKEY, E.A., ANDERSON, D.L., CLARK, D.D., Neutron Capture Prompt Gamma-ray Activation Analysis at the NIST Cold Neutron Research Facility, *J. Radioanal. Nucl. Chem.* **167** (1993) 121-126.
- [3.15] PAUL, R.L., LINDSTROM, R.M., HEALD, A.E., Cold Neutron Prompt Gamma-ray Activation Analysis at NIST - Recent Developments, *J. Radioanal. Nucl. Chem.* **215** (1997) 63-68.
- [3.16] STONE, C.A., BLACKBURN, D.H., KAUFFMAN, D.A., CRANMER, D.C., OLMEZ, I., ^6Li -doped Silicate Glass for Thermal Neutron Shielding, *Nucl. Instrum. Meth. Phys. Res.* **A349** (1994) 515-520.

- [3.17] FAZEKAS, B., MOLNÁR, G., BELGYA, T., DABOLCZI, L., SIMONITS, A., Introducing HYPERMET-PC for Automatic Analysis of Complex Gamma-ray Spectra, *J. Radioanal. Nucl. Chem.* **215** (1997) 271-277.
- [3.18] LINDSTROM, R.M., SUM and MEAN: Standard Programs for Activation Analysis, *Biol. Trace Elem. Res.* **43-45** (1994) 597-603.
- [3.19] MACKEY, E.A., Effects of Target Temperature on Analytical Sensitivities of Cold Neutron Capture Prompt Gamma-ray Activation Analysis, *Biol. Trace Elem. Res.* **43-45** (1994) 103-108.
- [3.20] RÉVAY, Zs., BELGYA, T., KASZTOVSZKY, Zs., WEIL, J.L., MOLNÁR, G.L., "Cold Neutron PGAA Facility at Budapest", IRRMA-V, Proc. 5th Int. Topical Meeting Industrial Radiation and Radioisotope Measurement Applications, Bologna, (2002) in press.
- [3.21] BELGYA, T., RÉVAY, Zs., FAZEKAS, B., HÉJJA, I., DABOLCZI, G.L., MOLNÁR, G.L., KIS, Z., ÖSTÖR, J., KASZÁS, Gy., "The New Budapest Capture Gamma-ray Facility", Proc. 9th Int. Symp. Capture Gamma-ray Spectroscopy and Related Topics, Budapest, 1997, (Molnár, G.L., Belgya, T., Révay, Zs., Eds.), Springer Verlag, Budapest (1997) 826-837.
- [3.22] MOLNÁR, G.L., RÉVAY, Zs., BELGYA, T., Wide-energy Range Efficiency Calibration Method for Ge-detectors, *Nucl. Instrum. Meth. Phys. Res.* **A489** (2002) 140-159.
- [3.23] RÉVAY, Zs., BELGYA, T., EMBER, P.P., MOLNÁR, G.L., Recent Developments in HYPERMET-PC, *J. Radioanal. Nucl. Chem.* **248** (2001) 401-405.
- [3.24] DE CORTE, F., SIMONITS, A., k_0 -measurements and Related Nuclear Data Compilation for (n, \square) Reactor Neutron Activation Analysis, IIIb: Tabulation, *J. Radioanal. Nucl. Chem.* **133** (1989) 43-130.
- [3.25] LONE, M.A., LEAVITT, R.A., HARRISON, D.A., Prompt Gamma Rays from Thermal-neutron Capture, *At. Data Nucl. Data Tables* **26** (1981) 511-559.
- [3.26] MUKOPADHYAY, P.K., Proc. Symp. Intelligent Nuclear Instrumentation, Mumbai (2001) 307.
- [3.27] RUYL, J.F.A.G., ENDT, P.M., Investigation of the $^{48}\text{Ti}(n,\gamma)^{49}\text{Ti}$ Reaction, *Nucl. Phys.* **A407** (1983) 60-76.
- [3.28] ACHARYA, R.N., SUDARSHAN, K., NAIR, A.G.C., SCINDIA, Y.M., GOSWAMI, A., REDDY, A.V.R., MANOHAR, S.B., Measurement of k_0 -factors in Prompt Gamma-ray Neutron Activation Analysis, *J. Radioanal. Nucl. Chem.* **250** (2001) 303-307.
- [3.29] SUDARSHAN, K., ACHARYA, R.N., NAIR, A.G.C., SCINDIA, Y.M., GOSWAMI, A., REDDY, A.V.R., MANOHAR, S.B., Determination of Prompt k_0 -Factors in PGNAA, pp. 39-50, Summary Report 2nd RCM of CRP on Development of a Database for Prompt Gamma-Ray Neutron Activation Analysis, INDC(NDS)-424, International Atomic Energy Agency, Vienna, Austria (2001).
- [3.30] SUDARSHAN, K., NAIR, A.G.C., ACHARYA, R.N., SCINDIA, Y.M., REDDY, A.V.R., MANOHAR, S.B., GOSWAMI, A., Capture Gamma-rays from Co-60 as Multi Gamma-ray Efficiency Standard for Prompt Gamma-ray Neutron Activation Analysis, *Nucl. Instrum. Meth. Phys. Res.* **A457** (2001) 180-186.
- [3.31] VUONG HUU TAN, NGUYEN CANH HAI, NGUYEN XUAN QUY, LE NGOC CHUNG, Evaluation and Measurement of Prompt k_0 -Factors to Use in Prompt Gamma-Ray Neutron Activation Analysis, pp. 33-38, Summary Report 2nd RCM of CRP on Development of a Database for Prompt Gamma-Ray Neutron Activation Analysis, INDC(NDS)-424, International Atomic Energy Agency, Vienna, Austria (2001).

- [3.32] RÉVAY, Z., MOLNÁR, G.L., Standardisation of the Prompt Gamma Activation Analysis Method, *Radiochim. Acta*, **91** (2003) 361-369.
- [3.33] PAUL, R.L., LINDSTROM, R.M., Measurement of k_0 -Factors for Prompt Gamma-Ray Activation Analysis, pp. 54-57, *Proc. 2nd Int. k_0 Users Workshop*, Jozef Stefan Institute, Ljubljana, Slovenia (1997).
- [3.34] MATSUE, H., YONEZAWA, C., Neutron Spectrum Correction of k_0 -factors for k_0 -based Neutron Induced Prompt Gamma-ray Analysis, *J. Radioanal. Nucl. Chem.* **255** (2003) 125-129.
- [3.35] MATSUE, H., YONEZAWA, C., Measurement and Evaluation of k_0 -factors for PGA at JAERI, *J. Radioanal. Nucl. Chem.*, **257**, No.3 (2003), 565-571.

4. BENCHMARKS AND REFERENCE MATERIALS □

R.M. Lindstrom

Two sets of sample materials were sent to the experimentalists within the CRP to aid in characterizing each neutron beam and detector system, and to analyze an unknown sample.

The first set of samples comprised the following:

- 99.65% titanium foil, 0.25-mm thick: 2.5-cm square, and 6- and 13-mm disks;
- Gold foil, 0.025-mm thick by 5-mm diameter;
- Borophosphosilicate glass on silicon: $\sim 5 \times 10^{16}$ atoms $^{10}\text{B cm}^{-2}$ (surface density measured by neutron depth profiling);
- ^{10}B -aluminum alloy sheet, 1.3-mm thick and 4.5 wt % ^{10}B as two ~ 2.5 cm squares;
- Approximately 2 g of an “unknown” mixture of aluminosilicate and graphite.

The titanium foil was used to measure the sensitivity of the PGAA system (i.e., the product of neutron flux and detector efficiency, expressed as the count rate per milligram of Ti of the 1381.5-keV capture gamma ray of ^{48}Ti). The effective velocity or wavelength of the beam can be measured by means of the boron samples, as described below. Excel spreadsheets for flux and wavelength were also developed and made available on the IAEA server; as illustrated below.

The unknown sample was distributed in order to demonstrate the participants’ ability to perform quantitative analysis. This material was made by blending dried and weighed quantities of two NIST fly ash Standard Reference Materials (SRMs 1633a and 1633b) with spectroscopic graphite as a diluent in a mixer mill. The participants were not informed about the constituents, or their proportions. The known values of eleven elements were calculated from the SRM certificates or from published consensus numbers. Unfortunately for the comparison, the concentrations of hydrogen and boron reported by all three participants are not known in SRM 1633b, so the “correct” value of these elements is unknown as well.

4.1. Characterization of the neutron beam

Foil activation is the simplest and perhaps the most accurate method of measuring the neutron flux [4.1]. A known mass of a monitor element is irradiated for a known time and the resulting radioactivity measured with a detector of known efficiency. If the reaction rate per atom ($R = \sigma\phi$) is calculated with the 2200 m s⁻¹ thermal cross section (for example, $\sigma_0 = 98.65$ b for ^{198}Au production), the thermal equivalent flux (ϕ_0) can be determined. Epithermal flux is often measured by irradiating a bare monitor and another specimen of the same monitor under 1-mm shielding of cadmium, as described in Section 2.2.2. Fast-neutron (MeV) monitoring is similar, using threshold reactions that cannot be induced by slow neutrons, such as $^{54}\text{Fe}(n, p)^{54}\text{Mn}$ [4.2].

The effective temperature (or wavelength) is a useful single parameter that has been devised to characterize a neutron beam in the thermal and subthermal energy region where most analytically useful reactions take place. This basic concept involves measuring the reaction

rate of a thin sample (proportional to the temperature-sensitive effective cross section), and comparing with the total flux incident on a “black” sample [4.3]. One approach involves the adoption of the same element for both samples, negating the need to determine the detector efficiency, but resulting in a large difference in count rate.

When the effects of neutron absorption and scattering can be neglected, the neutron capture rate (R) of a given element in an irradiated sample is proportional to the product of the number of atoms in the beam (N) and the neutron flux (ϕ), defined as the number of neutrons entering the sample per unit area per unit time:

$$R = N\phi\langle\sigma\rangle \quad (1)$$

where the effective cross section ($\langle\sigma\rangle$) is the constant of proportionality.

For a thin sample of area S with a known surface density D atoms cm^{-2} of the target species, $N = DS$, and therefore the counting rate C for a detection efficiency ε counts per capture is given by the equation:

$$C_{thin} = \varepsilon R_{thin} = \varepsilon SD\phi\langle\sigma\rangle \quad (2)$$

However, for a thick "black" sample of the same material, every neutron is captured, and the reaction rate is:

$$C_{thick} = \varepsilon S\phi \quad (3)$$

If thick and thin samples are identically irradiated (same sample area (S) and capture-gamma detection efficiency (ε)), the ratio of counting rates is given by:

$$\frac{C_{thin}}{C_{thick}} = \frac{\varepsilon SD\phi\langle\sigma\rangle}{\varepsilon S\phi} \quad (4)$$

from which the effective cross section can be derived:

$$\langle\sigma\rangle = \frac{C_{thin}}{D \cdot C_{thick}} \quad (5)$$

For a $1/v$ absorber for which the cross section is inversely proportional to the neutron velocity, the effective velocity $\langle v \rangle$ is defined as:

$$\langle v \rangle = v_0 \frac{\sigma_0}{\langle\sigma\rangle} \quad (6)$$

where by convention $v_0 = 2200 \text{ m s}^{-1}$. The corresponding effective wavelength is defined as

$$\langle\lambda\rangle = \frac{h}{m \cdot \langle v \rangle} \quad (7)$$

where h is Planck's constant, and m is the neutron mass. A spreadsheet in which these calculations can be performed is displayed below.

Neutron Beam Wavelength Measurement

Sample	Live time, s	Clock time, s	Dead time	count/s B @478	1s uncert
Thick boron	340.4	391.5	13.1%	6330.6	0.08%
Thin boron	29989.6	30409.8	1.4%	5.96	0.84%

	Input data		SI units		Equivalent natural B	
Thick source thickness	1.3	mm				
¹⁰ B content	4.5%					
Density	2.70	g/cm ³				
Thin deposit thickness D	4.83E+16	at ¹⁰ B/cm ²	4.83E+20	atom/m ²	4.05E-06	g/cm ²
angle with beam	45.0	deg	7.85E-01	radian		
thickness in beam direction	6.83E+16	at ¹⁰ B/cm ²	6.83E+20	atom/m ²	5.73E-06	g/cm ²

Results					
sigma(eff)	13,792	barn	1.38E-24	m ²	
sigma(eff)/sigma(0)	3.6				
v(eff)	612	m/s	612	m/s	
lambda(eff)	6.5	Å	6.47E-10	m	
E(eff)= mv ² /2	0.0020	eV	3.13E-22	J	
T(eff) = E/k	22.7	K			
Calculated absorption of thick source			99.9998%		
Calculated absorption of thin source			9.42E-08	(boron only)	

4.2. Analysis of the unknown sample

Three participants reported measurements of the composition of the unknown mix of silicate and graphite. Some adjustment was necessary to compare results because the Budapest measurements were forced to sum to 100% and the BARC measurements were normalized to an assumed (and incorrect) Fe concentration. Both sets of results were renormalized to the known Fe concentration of 5.35%. Table 4.1 summarizes the comparisons. Eight to ten elements were reported: about half of the elements of known concentrations in the mixture (not H or B) were measured correctly to within $\pm 25\%$. A weak comparison can be made by taking into account the measurement uncertainties (reported by two participants). About a third of the measured concentrations agreed with the expected values to within the stated uncertainties. If the true uncertainties of the expected values had been known and taken into account, this measure of PGAA performance would have been considerably better.

Table 4.1 Measurements made by the different laboratories.

Laboratory	BARC	IISC	NIST	SNU	VAEC	unit
Sensitivity	0.031	0.54	6.2	2.0		cps @1382/mg Ti
Neutron flux		4.3E+07	8.3E+08	7.9E+07		cm ⁻² s ⁻¹ , thermal equivalent
Effective neutron velocity		473	610	2120		m s ⁻¹
Unknown sample analysis						
Elements reported	8	11		10		
Number within 25%	4	6		5		
Number within stated uncertainty		3		4		

4.3. Cross-section measurements

A second set of materials was distributed to assist in the resolution of a discrepancy in the thermal cross section of carbon. These materials were as follows:

- ~ 2 g of urea (NH₂)₂CO (NIST Standard Reference Material 912, 99.7 %);
- ~ 1.2 g of deuterourea (ND₂)₂CO (Aldrich 176087, 98+ at.% D);
- ~ 2.5 g of melamine C₃N₃(NH₂)₃ (Fisher ACROS 220481, assay ≥ 99%);
- spectroscopic graphite (Union Carbide UCAR L4100, palletising grade).

No results from these materials have been reported to NIST.

REFERENCES

- [4.1] Standard E 261-98, Standard Practice for Determining Neutron Fluence, Fluence Rate, and Spectra by Radioactivation Techniques, ASTM International, West Conshohocken, PA, (1998).
- [4.2] CALAMAND, A., "Cross-Sections for Fission Neutron Spectrum Induced Reaction", in Handbook on Nuclear Activation Cross-Section, Technical Report 156, IAEA Vienna, Austria (1974) 273-324.
- [4.3] RÉVAY, Z., private communication (2000), Institute of Isotope and Surface Chemistry, Budapest, Hungary.

5. THERMAL NEUTRON CAPTURE CROSS SECTIONS AND NEUTRON SEPARATION ENERGIES

R.B. Firestone, S.F. Mughabghab, G.L. Molnár

Thermal radiative neutron capture cross sections have been re-evaluated [5.1] as part of an ongoing project at the National Nuclear Data Center at Brookhaven National Laboratory to update the *Neutron Cross Sections* compendia, Vol. 1, parts A and B, *Neutron Resonance Parameters and Thermal Capture Cross Sections*, published by Academic Press in 1981 and 1984 [5.2, 5.3]. Neutron separation energies are evaluated as part of an on-going project at the Atomic Mass Data Center in Orsay, France [5.4]. The adopted data are compared with new results derived from this evaluation.

5.1. Thermal cross-section evaluation methodology

A brief description of the evaluation procedure is presented below. As an initial step in the evaluation procedure, CINDA retrievals were carried out on nuclear parameters, such as thermal capture, scattering and total cross sections, as well as coherent scattering amplitudes for measurements since 1979, the cut-off date of the publication of *Neutron Cross Sections*, Vol.1, part A. The search engines of the American Physical Society and Elsevier Science Web sites were utilized for the most recent publications that may not be referenced in CINDA.

Since the present evaluated capture cross sections are applied to test the validity of the k_0 methodology described elsewhere in this report, the capture cross sections derived by this technique were not included in the present evaluation. As in other previous evaluation studies [5.2, 5.3], various factors were considered in evaluating the thermal capture cross sections:

Normalization of the reported cross section under consideration to recent recommended standard cross sections (^1H , ^{14}N , ^{35}Cl , ^{55}Mn , ^{59}Co , ^{197}Au and ^{235}U).

- a. Half-lives of the product nuclei, branching ratios, and conversion coefficients.
- b. Measurement accuracy.
- c. Measurement method, as to whether it is specific or non-specific, such as an absorption measurement by a pile oscillator method as compared to quantification by an activation method.
- d. Sample characteristics, which include information regarding the isotopic enrichment, impurities, chemistry and sample thickness.
- e. Measurer's experience and general consistency.
- f. Characterization of the neutron spectrum.
- g. Paramagnetic scattering cross sections of rare earth nuclei in dealing with total cross sections.
- h. Accurate total cross-section measurements, from which capture cross sections can be obtained if the scattering cross sections are well known.

In some cases, measured reactor capture cross sections can be converted to 2200 m s^{-1} values if the thermal reactor-index and the capture-resonance integrals are known.

For light and medium weight nuclides, as well as near-magic nuclides, the direct capture cross section is computed within the framework of the Lane-Lynn theory [5.5-5.7] following the Mughabghab procedure outlined in Ref. [5.6], and can shed some light on the measured capture cross section.

In the final step of the evaluation procedure, the contribution of positive-energy resonances to the thermal capture cross section is computed and subsequently compared with measurements. For the majority of nuclides, negative-energy resonances are postulated to achieve consistency between calculations and measurements. However, in some cases, the computed thermal capture cross section can be accounted for in terms of positive-energy resonances, such as ^{162}Dy [5.3].

Finally, consistency between the isotopic and elemental cross sections is sought. Several iterations in the evaluation procedure may be necessary for this objective to be realized.

5.2. Adopted thermal neutron cross sections

The resulting evaluated thermal neutron capture cross sections for elements $Z=1-92$ are summarized in column 3 of Table 5.1 for 395 naturally abundant isotopes and isomers [5.1-5.3]. The quoted natural abundances, listed in column 2, are representative isotopic compositions (Atom %) from the 1997 IUPAC values published by Rosman and Taylor [5.8]. The uncertainties of the presently evaluated capture cross-sections have been substantially reduced for the following nuclides:

^{14}N , ^{24}Mg , ^{25}Mg , ^{28}Si , ^{29}Si , ^{30}Si , ^{32}S , ^{33}S , ^{36}S , ^{47}Ti , ^{49}Ti , ^{51}V , ^{55}Mn , ^{58}Fe , ^{66}Zn , ^{71}Ga , ^{73}Ge , ^{74}Ge , ^{75}As , ^{79}Br , ^{81}Br , ^{82}Kr , ^{83}Kr , ^{105}Pd , ^{108}Cd , ^{117}Sn , ^{128}Xe , ^{136}Ba , ^{137}Ba , ^{146}Nd , ^{148}Nd , ^{150}Nd , ^{144}Sm , ^{156}Gd , ^{174}Yb , ^{174}Hf , ^{182}W , ^{187}Os , ^{192}Os , ^{190}Pt and ^{232}Th .

Also, in the cases of

^9Be , ^{33}S , ^{36}S , ^{49}Ti , ^{104}Ru , ^{117}Sn , ^{128}Xe , ^{137}Ba , ^{144}Sm , ^{187}Os , ^{192}Os , ^{190}Pt , ^{196}Pt , ^{206}Pb , ^{207}Pb and ^{208}Pb ,

the most recent recommended capture cross sections [5.1] are not consistent with previous evaluation [5.2, 5.3], lying outside the sum of the uncertainties of previous and present recommendations. Of particular importance is the significant change of the capture cross section of ^{207}Pb from 0.712 ± 0.010 b to 0.620 ± 0.014 b.

5.3. Experimental thermal neutron cross sections

Thermal neutron cross sections have been derived from the evaluated gamma-ray production cross sections discussed in Chapter 7, and are shown in column 4 of Table 5.1. These values are derived from the sum of primary gamma-ray cross sections de-exciting the capture state and/or secondary gamma-ray cross sections populating the ground state and isomers, as indicated in columns 5 and 6 of Table 5.1, and from selected decay gamma-ray cross sections. The primary gamma-ray cross sections are typically incomplete due to large, unobserved statistical feedings, except for the light nuclei. Secondary gamma-ray intensities are also incomplete, but often the total intensity populates only a few gamma rays leading to reliable total cross section determination. Cross sections derived from decay gammas were corrected for neutron irradiation time and are expected to be very reliable. All other cross sections may be considered as lower limits, depending on the completeness of the data.

Inspection of the measured cross sections shows that agreement with the experimentally deduced values is fairly good, especially for light nuclides, and the precision has been improved in many cases. One notable discrepancy is the cross section for ^{12}C where the new value of 3.89 ± 0.06 mb exceeds the adopted value of 3.53 ± 0.07 mb by 11 ± 3 %. A summary of the eleven measurements [5.9-5.19] considered in deriving the adopted value is

given in Table 5.2. Four measurements agree with the new value within one standard deviation, and five measurements disagree by more than two standard deviations.

In view of the importance of the carbon cross section, new experiments were performed at Budapest on four different compounds containing carbon with a well defined stoichiometry to test the accuracy of the new value. These measurements yielded a cross section of 3.87 ± 0.05 mb, in excellent agreement with the earlier value. Other recent values deduced from JAERI k_0 -factors [5.20, 5.21] are 3.63 ± 0.13 mb for their cold neutron guide and 4.01 ± 0.15 mb for their thermal neutron guide, which appear to corroborate the new value. All of the measurements discussed in Table 5.2 were performed with external comparator standards and may be susceptible to error due to neutron scattering, so we recommend that the new internally calibrated value should be adopted in the future.

^{14}N is an important standard for thermal neutron capture cross section and gamma-ray spectra measurements. The measured capture cross sections for this nuclide [5.17, 5.22, 5.23] are presented in Table 5.3. The adopted value of 79.8 ± 1.4 mb [5.1] agrees well with the new value of 79.0 ± 0.9 mb from this work. All of the measured values except one of Islam [5.22] agree within their uncertainties. The discrepant value is based on a ^{207}Pb standard that in turn was based on the adopted ^{12}C standard which we have shown to be too low. Adjusting this value to the new ^{12}C measurement gives 76.4 ± 1.9 mb which is in reasonable agreement with all other values.

5.4. Neutron separation energies

Neutron separation energies (S_n) have been evaluated as part of an ongoing effort at the Atomic Mass Data Center in Orsay, France [5.4]. The most recent S_n values are shown in column 7 of Table 5.1. The gamma-ray energies from this evaluation have undergone least-squares fits to the level scheme to derive “best” level energies including S_n for the capture state. The energies are corrected for the nuclear recoil and uncertainties are adjusted for outliers as described in Chapter 6. The new S_n values are shown in column 8 of Table 5.1; agreement is generally good and greater precision has been achieved in most cases.

REFERENCES

- [5.1] MUGHABGHAB, S.F., Thermal Neutron Capture Cross Sections, Resonance Integrals, and g-factors, INDC(NDS)-440 (2003).
- [5.2] MUGHABGHAB, S.F., DIVADEENAM, M., HOLDEN, N., Neutron Cross Sections, Vol. 1, Part A, Z = 1-60, Academic Press, New York, 1981.
- [5.3] MUGHABGHAB, S.F., Neutron Cross Sections, Vol. 1, Part B, Z = 61-100, Academic Press, New York, 1984.
- [5.4] AUDI, G., WAPSTRA, A.H., The 1995 update to the atomic mass evaluation, Nucl. Phys. **A595** (1995) 409.
- [5.5] LANE, A.M., LYNN, J.E., Theory of radiative capture in the resonance region, Nucl. Phys. **17** (1960) 563; *ibid*, Anomalous radiative capture in the neutron resonance region: Analysis of the experimental data on electric dipole transitions, Nucl. Phys. **17** (1961) 586.
- [5.6] MUGHABGHAB, S.F., Verification of the Lane-Lynn theory of direct neutron capture^{*1}, Phys. Letts. **81B** (1979) 93.
- [5.7] MUGHABGHAB, S.F., CHRIEN, R.E., “Neutron Capture Gamma-Ray Spectroscopy”, pp. 265 in Proc. 3rd Int. Symp. Neutron Capture Gamma-ray Spectroscopy and Related Topics, 18-22 September 1978, Brookhaven National

- Laboratory and State University of New York, Chrien, R.E., Kane, W.R. (Eds.), Plenum Press, New York, 1979.
- [5.8] ROSMAN, K.J.R., TAYLOR, P.D.P., "Isotopic Composition of the Elements 1997", *Pure Appl. Chem.* **70** (1998) 217.
- [5.9] HENDRIE, J.M., PHELPS, J.P., PRICE, G.A., WEINSTOCK, E.V., Slowing down and diffusion lengths of neutrons in graphite-bismuth systems, *Nucl. Sci. Eng.* **18** (1964) 410.
- [5.10] HENNING, G.R., "The Slow Neutron Absorption Cross Section of Graphite", pp. 19-20 in *Proc. French-American Conf. Graphite Reactors*, BNL-489 (1957).
- [5.11] MUEHLHAUSE, C.O., HARRIS, S.P., ROSE, D., SCHROEDER, H.P., THOMAS, G.E., WEXLER, S., pp.12 in *Proc. French-American Conf. Graphite Reactors*, BNL-489 (1957).
- [5.12] French measurements cited by NICHOLS, P.F., in Ref. 16.
- [5.13] KOECHLIN, J.C., TANGUY, P., ZALETSKI, C.P., "French Results on Natural Uranium-Graphite Reactors", BNL-489 (1957).
- [5.14] SAGOT, M., TELLIER, H., Letters to the Editor, *Mesure des paramètres de diffusion du graphite*, *Reactor Sci. Technol. (J. Nucl. Energy A/B)* **17** (1963) 347.
- [5.15] STARR, E.G., PRICE, G., "Measurement of the Diffusion Parameters of Graphite and Graphite-Bismuth by Pulsed Neutron Methods", pp. 1034-1073 in *Proc. Brookhaven Conf. Neutron Thermalization*, BNL-719 (1962) 1034.
- [5.16] NICHOLS, P.F., Absorption Cross Section of Graphite, *Nucl. Sci. Eng.* **7** (1960) 395.
- [5.17] JURNEY, E.T., MOTZ, H.T., "Thermal Neutron Capture in D and ^{16}O ", pp. 236 in *Int. Conf. Neutron Physics with Reactor Neutrons*, ANL-6797 (1963) 236.
- [5.18] JURNEY, E.T., BENDT, P.J., BROWNE, J.C., Thermal neutron capture cross section of deuterium, *Phys. Rev.* **C25** (1982) 2810.
- [5.19] PRESTWICH, W.V., ISLAM, M.A., KENNETT, T.J., A determination of the carbon thermal neutron capture cross section, *Nucl. Sci. Eng.* **78** (1981) 182.
- [5.20] MATSUE, H., YONEZAWA, C., Neutron spectrum correction of k₀-factors for k₀-based neutron-induced prompt gamma-ray analysis, *J. Radioanal. Nucl. Chem.* **255** (2003) 125.
- [5.21] [5.21] MATSUE, H., YONEZAWA, C., Measurement and evaluation of k₀ factors for PGA at JAERI, *J. Radioanal. Nucl. Chem.* **257** (2003) 565-571.
- [5.22] ISLAM, M.A., KENNETT, T.J., PRESTWICH, W.V., Re-estimation of the thermal neutron capture cross section of ^{14}N , *Nucl. Instrum. Meth. Phys. Res.* **A287** (1990) 460.
- [5.23] ISLAM, M.A., PRESTWICH, W.V., KENNETT, T.J., Determination of the thermal radiative capture cross section of ^{14}N , *Nucl. Instrum. Meth. Phys. Res.* **188** (1981) 243.

Table 5.1 Comparison of adopted neutron cross sections σ_γ [5.1-5.3] and neutron separation energies Sn [5.4] with the results of this evaluation. Total isotopic (n, γ) cross sections are shown except when the cross section populating a specific level or reaction is indicated. Adopted neutron separation energies were calculated from least-squares fits of the primary gamma-ray energies to the level scheme, and the adopted cross sections are based on primary, secondary and/or decay gamma-ray cross sections. In many cases the decay scheme may be incomplete so the adopted cross sections should be considered as lower limits.

Isotope and (E), (mode)	Percent Abundance ⁸	σ_γ (mb or b)				Sn (keV)	
		Mughabghab ¹⁻³	This work	Secondary	Primary	Audi ⁴	This work
1H	99.9885(70)	332.6(7) mb	Standard			2224.5725(22)	2224.576(19)
2H	0.0115(70)	0.519(7) mb	0.492(25) mb			6257.2482(24)	
3He	0.000137(3)	0.031(9) mb				20577.62	
4He	99.999863(3)						
6Li	7.59(4)	39(3) mb	52.6(22) mb	52.7(21) mb	52.5(22) mb	7249.96(9)	7249.94(4)
6Li(n, α)		940(4) b					
7Li	92.41(4)	45(3) mb	45.7(9) mb	45.7(9) mb	45.7(9) mb	2033.8(3)	2032.57(4)
9Be	100	8.8(4) mb	8.8(6) mb	8.8(6) mb	8.9(6) mb	6812.33(6)	6812.10(3)
10B	19.9(7)	500(200) mb	303(20) mb	306(16) mb	298(15) mb	11454.12(20)	11454.15(14)
10B(n, α)		3837(9) b	3820(135) b				
11B	80.1(7)	6(3) mb				3370.4(14)	
12C	98.93(8)	3.53(7) mb	3.89(6) mb	3.89(6) mb	3.90(6) mb	4946.310(10)	4946.311(3)
13C	1.07(8)	1.37(4) mb	1.22(6) mb	1.22(6) mb	1.21(11) mb	8176.440(10)	8176.61(18)
14N	99.632(7)	79.8(14) mb	79.0(9) mb	78.8(9) mb	79.6(16) mb	10833.230(10)	10833.317(12)
14N(n, p)		1.83(3) b					
15N	0.368(7)	24(8) mb				2490.8(23)	
16O	99.757(16)	0.190(19) mb	0.189(8) mb	0.177(11) mb	0.194(7) mb	4143.33(21)	4143.06(10)
17O	0.038(1)	0.54(7) mb		0.54(11) mb	0.49(7) mb	8044.4(8)	8043.5(10)
17O(n, α)		235(10) mb					
18O	0.205(14)	0.16(1) mb				3957(3)	
19F	100	9.6(5) mb	9.50(11) mb	9.49(11) mb	9.51(14) mb	6601.31(5)	6601.344(16)

Isotope and (E), (mode)	Percent Abundance ⁸	σ_{γ} (mb or b)			Sn (keV)		
		Mughabghab ¹⁻³	This work	Secondary	Primary	Audi ⁴	This work
20Ne	90.48(3)	37(4) mb		36.9(5) mb	37(3) mb	6761.11(4)	6761.19(5)
21Ne	0.27(1)	670(110) mb		670(190) mb	580(100) mb	10363.96(23)	10363.9(4)
22Ne	9.25(3)	45(6) mb		44(6) mb	44(2) mb	5200.62(12)	5200.64(17)
23Na	100	530(5) mb	527(7) mb	516(4) mb	527(7) mb	6959.44(5)	6959.592(15)
23Na(472)		400(30) mb	478(4) mb				
24Mg	78.99(4)	53.6(15) mb	53.7(14) mb	53.6(14) mb	53.9(14) mb	7330.67(4)	7330.53(4)
25Mg	10.00(1)	200(5) mb	197(5) mb	197(5) mb	192.8(22) mb	11093.09(4)	11093.157(21)
26Mg	11.01(3)	38.6(6) mb	37.7(13) mb	37.2(13) mb	38.3(14) mb	6443.35(4)	6443.35(3)
27Al	100	231(3) mb	232(3) mb	232(3) mb	187.2(17) mb	7725.05(6)	7725.170(4)
28Si	92.2297(7)	177(5) mb	186(3) mb	187(3) mb	185.2(23) mb	8473.56(3)	8473.537(23)
29Si	4.6832(5)	119(3) mb	118(3) mb	117(3) mb	120(3) mb	10609.18(3)	10609.23(3)
30Si	3.0872(5)	107(2) mb	116(3) mb	116(3) mb	117(7) mb	6587.40(5)	6587.39(3)
31P	100	172(6) mb	167(5) mb	167(5) mb	159.1(22) mb	7935.65(4)	7935.596(23)
32S	94.93(31)	548(10) mb	536(8) mb	528(8) mb	543(8) mb	8641.58(3)	8641.809(25)
33S	0.76(2)	454(25) mb	461(15) mb	461(15) mb	383(14) mb	11416.94(5)	11417.219(16)
34S	4.29(28)	235(5) mb	277(8) mb	277(8) mb	278(19) mb	6985.84(4)	6986.091(15)
36S	0.02(1)	230(20) mb		230(25) mb	247(21) mb	4303.58(9)	4303.61(4)
35Cl	75.78(4)	43.6(4) b	43.84(17) b	43.84(17) b	41.89(20) b	8579.70(7)	8579.672(18)
37Cl	24.22(4)	430(6) mb	553(23) mb	553(23) mb	550(40) mb	6107.78(10)	6107.73(9)
36Ar	0.3365(30)	5.2(5) b		5.2(8) b	4.1(7) b	8788.9(4)	8789.9(9)
38Ar	0.0632(5)	800(200) mb				6598(5)	
40Ar	99.6003(30)	660(10) mb		710(50) mb	660(40) mb	6098.7(6)	6099.1(4)
39K	93.2581(44)	2.1(2) b	2.19(3) b	2.19(3) b	1.737(14) b	7799.50(8)	7799.558(14)
40K	0.0117(1)	30(4) b	76(3) b	96(15) b	76(3) b	10095.18(10)	10095.255(15)
41K	6.7302(44)	1.46(3) b	1.64(6) b	1.64(6) b	1.37(5) b	7533.77(15)	7533.822(10)
40Ca	96.94(16)	410(20) mb	415(7) mb	415(7) mb	378(6) mb	8363.7(3)	8362.86(5)
42Ca	0.647(23)	680(70) mb	740(40) mb	740(40) mb	670(80) mb	7933.0(3)	7932.73(16)
43Ca	0.135(10)	6.2(6) b	7.3(5) b	7.3(5) b	3.3(2) b	11132.0(7)	11131.54(18)
44Ca	2.09(11)	880(50) mb	1055(25) mb	1055(25) mb	990(70) mb	7414.8(3)	7414.79(15)

Isotope and (E), (mode)	Percent Abundance ⁸	σ_{γ} (mb or b)			Sn (keV)		
		Mughabghab ¹⁻³	This work	Secondary	Primary	Audi ⁴	This work
46Ca	0.004(3)	720(30) mb		730(70) mb	750(60) mb	7276.1(5)	7276.1(3)
48Ca	0.187(21)	1090(70) mb	1050(120) mb	920(110) mb	1050(120) mb	5146.6(4)	5146.48(21)
45Sc	100	27.2(2) b	26.28(23) b	26.28(23) b	19.29(24) b	8760.62(11)	8760.745(20)
45Sc(143)		9.8(11) b	7.78(11) b				
46Ti	8.25(3)	590(180) mb	310(16) mb	229(19) mb	310(16) mb	8877.7(10)	8880.5(3)
47Ti	7.44(2)	1.52(11) b	1.63(4) b	1.63(4) b	1.177(11) b	11626.59(4)	11626.657(14)
48Ti	73.72(3)	7.88(25) b	8.6(3) b	8.32(16) b	8.84(15) b	8142.36(5)	8142.351(14)
49Ti	5.41(2)	1.79(12) b	1.88(4) b	1.88(4) b	1.675(18) b	10939.13(4)	10939.201(13)
50Ti	5.18(2)	179(3) mb	172(3) mb	142(2) mb	172(3) mb	6372.3(9)	6372.6(6)
50V	0.250(4)	21(4) b	20.4(8) b	20.4(8) b	13.5(3) b	11051.28(9)	11051.142(24)
51V	99.750(4)	4.92 b 4	5.18(18) b	5.18(18) b	4.65(11) b	7311.24(23)	7311.273(15)
50Cr	4.345(13)	15.9(2) b	15.73(21) b	15.73(21) b	16.0(5) b	9261.6(3)	9260.63(8)
52Cr	83.789(18)	760(60) mb	871(14) mb	871(14) mb	855(17) mb	7939.17(16)	7939.10(23)
53Cr	9.501(17)	18.2(15) b	19.0(4) b	19.0(4) b	18.2(6) b	9719.01(25)	9720.00(5)
54Cr	2.365(7)	360(40) mb	440(40) mb	440(40) mb	390(40) mb	6246.3(4)	6246.28(17)
55Mn	100	13.36(5) b	11.33(9) b	11.36(10) b	11.31(9) b	7270.5(3)	7270.419(25)
54Fe	5.845(35)	2.25(18) b	2.44(6) b	2.31(10) b	2.44(6) b	9297.9(3)	9298.53(19)
56Fe	91.754(36)	2.59(14) b	2.49(5) b	2.49(5) b	2.447(24) b	7646.03(10)	7646.0954(6)
57Fe	2.119(10)	2.5(3) b	1.9(5) b	1.9(5) b	1.5(5) b	10044.5(3)	10044.65(14)
58Fe	0.282(4)	1.30(3) b	1.30(5) b	1.30(5) b	1.20(2) b	6580.90(20)	6581.02(6)
59Co	100	37.18(6) b	38.4(3) b	38.4(3) b	32.4(5) b	7491.93(8)	7492.05(3)
59Co(59)		20.4(8) b	20.76(20) b				
58Ni	68.077(9)	4.5(2) b	4.36(5) b	4.36(5) b	4.30(5) b	8999.44(14)	8999.151(15)
60Ni	26.223(8)	2.9(2) b	2.42(3) b	2.42(3) b	2.36(3) b	7820.04(10)	7820.055(21)
61Ni	1.1399(6)	2.5(8) b	1.65(12) b	1.65(12) b	1.28(11) b	10597.2(4)	10595.6(3)
62Ni	3.6345(17)	14.5(3) b	14.99(22) b	14.99(22) b	14.97(22) b	6837.85(7)	6837.89(3)
64Ni	0.9256(9)	1.63(7) b	2.2(3) b	2.2(3) b	2.1(4) b	6098.01(20)	6098.28(14)
63Cu	69.17(3)	4.52(2) b	4.75(4) b	4.75(4) b	4.74(11) b	7915.96(11)	7916.14(4)
65Cu	30.83(3)	2.17(3) b	2.134(18) b	2.134(18) b	1.81(3) b	7065.93(11)	7066.13(4)

Isotope and (E), (mode)	Percent Abundance ⁸	σ_{γ} (mb or b)			Sn (keV)		
		Mughabghab ¹⁻³	This work	Secondary	Primary	Audi ⁴	This work
64Zn	48.6(6)	1100(100) mb	843(20) mb	843(20) mb	627(7) mb	7979.6(5)	7979.28(7)
66Zn	27.9(3)	620(60) mb	376(6) mb	375(6) mb	360(20) mb	7052.2(4)	7052.5(3)
67Zn	4.10(13)	9.5(14) b	11.44(14) b	11.44(15) b	4.93(11) b	10198.2(5)	10198.06(7)
68Zn(0)	18.8(5)	1000(100) mb	790(50) mb	790(50) mb	660(40) mb	6482.2(5)	6482.07(10)
69Zn(439)		72(4) mb	68(9) mb				
70Zn(0)	0.62(3)	83(5) mb				5834(10)	
70Zn(158)		8.7(5) mb					
69Ga	60.108(9)	1.68(7) b	1.753(16) b	1.753(16) b	0.373(11) b	7655.1(8)	7653.65(8)
71Ga	39.892(9)	4.73(15) b	4.29(17) b	4.29(17) b	2.61(4) b	6521.0(10)	6520.44(14)
71Ga(120)		150(50) mb	429(9) mb				
70Ge	20.8(9)	3.45(16) b	3.69(7) b	3.69(7) b	1.71(10) b	7415.90(5)	7415.925(23)
70Ge(198)		280(70) mb	400(30) mb				
72Ge	27.54(34)	950(110) mb	770(80) mb	770(80) mb	620(19) MB	6782.90(5)	6783.12(6)
72Ge(67)			460(40) mb				
73Ge	7.73(5)	14.4(4) b	16.5(3) b	16.5(3) b	5.43(18) b	10196.20(6)	10196.056(13)
74Ge	36.3(7)	530(50) mb	505(10) mb	505(10) mb	231(13) mb	6505.22(8)	6505.45(4)
75Ge(140)		170 mb 30	164 mb 5				
76Ge(0)	7.61(38)	140(20) mb	140(30) mb	140(30) mb	330(60) mb	6072.6(11)	6072.3(4)
76Ge(160)		100(10) mb	155(21) mb				
75As	100	4.23(8) b	4.01(5) b	4.01(5) b	3.07(4)	7328.44(7)	7328.808(8)
74Se	0.89(4)	51.8(12) b	49(3) b	49(3) b	27(7) b	8027.53(8)	8027.585(18)
76Se	9.37(29)	85(7) b	84.3(8) b	84.3(8) b	46.6(9) b	7418.81(7)	7418.850(21)
76Se(162)		22(1) b	17.2(4) b				
77Se	7.63(16)	42(4) b	36.3(7) b	36.3(7) b	18.4(5) b	10498.0(3)	10497.75(3)
78Se(0)	23.77(28)	50(10) mb	98(15) mb	198(6) mb	9 mb	6962.9(7)	6963.11(10)
78Se(96)		380(20) mb	135(30) mb				
80Se(0)	49.61(41)	530(50) mb	441(17) mb	545(18) mb	280(60) mb	6701.0(6)	6700.9(5)
80Se(103)		80(10) mb	104(7) mb				
82Se(0)	8.73(22)	5.2(4) mb				5818(3)	

Isotope and (E), (mode)	Percent Abundance ⁸	σ_{γ} (mb or b)			Sn (keV)		
		Mughabghab ¹⁻³	This work	Secondary	Primary	Audi ⁴	This work
82Se(228)		39(3) mb					
79Br	50.69(7)	10.32(13) b	8.97(14) b	8.97(14) b	1.035(13) b	7892.19(20)	7892.41(8)
79Br(86)		2.4(6) mb	2.16(6) b				
81Br	49.31(7)	2.36(5) b	2.40(10) b	2.40(10) b	0.50(2) b	7592.90(20)	7593.017(22)
81Br(46)		2.4(4) b	2.32(10) b				
78Kr	0.35(2)	4.7(7) b				8355(8)	
78Kr(130)		170(20) mb					
80Kr	2.28(6)	11.5(5) b				7872(3)	
80Kr(190)		4.6(7) b					
82Kr	11.58(14)	19(4) b				7464(4)	
82Kr(42)		14.0(25) b					
83Kr	11.49(6)	202(10) b		180(3) b	41.1(4) b	10520.4(19)	10520.60(25)
84Kr	57.00(4)	111(15) mb				7119(4)	
84Kr(305)		90(13) mb					
86Kr	17.3(2)	3(2) mb		3.0(3) mb	2.8(4) mb	5515.4(8)	5515.20(25)
85Rb(0)	72.17(2)	427(11) mb	426(7) mb	426(7) mb	94(2) mb	8651.2(10)	8650.98(10)
85Rb(556)		53(5) mb	57.4(14) mb				
87Rb	27.83(2)	120(30) mb	122(4) mb	95(2) mb	44(2) mb	6080(3)	6082.52(11)
84Sr	0.56(1)	620(60) mb	630(80) mb	630(80) mb	300(50) mb	8529(4)	
84Sr(239)		600(60) mb	300(50) mb				
86Sr(0)	9.86(1)	200(30) mb	124(10) mb	1090(30) mb	910(17) mb	8428.12(17)	8428.170(15)
86Sr(389)		840(60) mb	970(30) mb				
87Sr	7.00(1)	17(3) b	15.0(3) b	15.0(3) b	8.31(9) b	11112.63(22)	11112.64(3)
88Sr	82.58(1)	5.8(4) mb	4.1(4) mb	4.1(4) mb	8.9(11) mb	6358.71(13)	6358.73(4)
89Y	100	1.28(2) b	1.282(13) b	1.282(13) b	1.22(4) b	6857.08(15)	6857.008(17)
89Y(682)		1.0(2) mb	1.8(5) mb				
90Zr	51.45(40)	11(5) mb	470(40) mb	470(40) mb	5.6(25) mb	7194.6(5)	7192.7(8)
91Zr	11.22(5)	1240(250) mb	1210(40) mb	1210(40) mb	405(21) mb	8634.8(3)	8635.00(16)
92Zr	17.15(8)	220(60) mb	101(5) mb	101(5) mb	46(3) mb	6734.2(6)	6735.3(7)

Isotope and (E), (mode)	Percent Abundance ⁸	σ_{γ} (mb or b)			Sn (keV)		
		Mughabghab ¹⁻³	This work	Secondary	Primary	Audi ⁴	This work
94Zr	17.38(28)	49.9(24) mb	110(9) mb	110(9) mb	32(4) mb	6462.6(9)	6357.8(3)
96Zr	2.80(9)	22.9(10) mb	920(30) mb	920(30) mb	82(14) mb	5580(3)	5575.1(4)
93Nb	100	1.15(5) b	1.138(14) b	1.138(14) b	0.828(8) b	7227.47(9)	7227.631(13)
93Nb(41)			783 mb 13				
92Mo	14.84(35)	19 mb	82(9) mb	82(9) mb	31(4) mb	8069.71(9)	8070.0(3)
94Mo	9.25(12)	15 mb	340(30) mb	340(30) mb	42(4) mb	7369.06(10)	7368.4(5)
95Mo	15.92(13)	13.4(3) b	13.6(4) b	13.6(4) b	2.30(6) b	9154.26(5)	9153.90(9)
96Mo	16.68(2)	500(200) mb	780(40) mb	780(40) mb	220(20) mb	6821.13(25)	6821.5(4)
97Mo	9.55(8)	2.5(2) b	2.20(7) b	2.20(7) b	0.50(11) b	8642.50(7)	8642.57(6)
98Mo	24.13(31)	137(5) mb	160(30) mb	160(30) mb	28 mb	5925.39(15)	5927.7(5)
100Mo	9.63(23)	199(3) mb	150(13) mb	150(13) mb	50(4) mb	5398.50(20)	5398.27(8)
96Ru	5.54(14)	220(20) mb	270(30) mb	270(30) mb	0	8112(3)	
98Ru	1.87(3)	<8 b	>480 mb	480(90) mb	0	7464(7)	
99Ru	12.76(14)	7.1(10) b	13.7(10) b	13.7(10) b	3.03(14) b	9673.16(14)	9673.413(19)
100Ru	12.60(7)	5.0(6) b	0.93(5) mb	0.93(5) b	0.69(3) b	6802.1(7)	6802.04(21)
101Ru	17.06(2)	3.4(9) b	6.4(5) b	6.4(5) b	1.34(7) b	9219.59(5)	9219.632(15)
102Ru	31.55(14)	1.21(7) b	2.5(1) mb	2.5(1) b	0.49(3) b	6232.4(3)	6232.00(11)
102Ru(238)			120(13) mb				
104Ru	18.62(27)	470(20) mb	860(40) mb	860(40) mb	570(90) mb	5910.07(19)	5910.11(7)
103Rh	100	145(2) b	156(5) b	103(2) b	7.69(10) b	6999.05(6)	6998.946(24)
103Rh(129)		10(1) b	9.7(8) b				
102Pd	1.02(1)	3.4(3) b	1.11(22) b	1.11(22) b	0	7624.7(15)	7625.6(9)
104Pd	11.14(8)	600(300) mb	373(25) mb	373(25) mb	0	7094.1(7)	
105Pd	22.33(8)	21.0(15) b	19.95(18) b	19.95(18) b	0.55(3) b	9561.5(3)	9561.4(4)
106Pd(0)	17.33(8)	290(30) mb	197(12) mb	197(12) mb	44(11) mb	6539(7)	6536.4(5)
106Pd(242)		13(2) mb					
108Pd	26.46(9)	7.6(4) b	7.01(6) b	7.01(6) b	2.76(9) b	6153.3(3)	6153.54(12)
108Pd(189)		180(30) mb	185(10) mb				
110Pd(0)	11.72(9)	190(30) mb	160(30) mb	144(25) mb	175(25) mb	5750(40)	5726.3(4)

Isotope and (E), (mode)	Percent Abundance ⁸	σ_{γ} (mb or b)			Sn (keV)		
		Mughabghab ¹⁻³	This work	Secondary	Primary	Audi ⁴	This work
110Pd(172)		36(6) mb					
107Ag	51.839(8)	37.6(12) b	38.2(5) b	38.2(5) b	3.08(9) b	7269.6(6)	7271.41(8)
107Ag(109)		330(80) mb	170(40) mb				
109Ag(0)	48.161(8)	86(3) b	78(3) b	78(3) b	10.21(11) b	6809.20(10)	6808.20(9)
109Ag(118)		4.7(2) b	8.82(16) b				
106Cd	1.25(6)	~1 b				7926(9)	
108Cd	0.89(3)	720(130) mb				7324(6)	
110Cd	12.49(18)	11(1) b		11.0(6) b	0.147(13) b	6975.84(19)	6975.1(4)
110Cd(396)		140(50) mb	780(70) mb				
111Cd	12.80(12)	24(3) b		24(3) b	0	9398.1(22)	
112Cd	24.13(21)	2.2(5) b				6540.2(6)	
113Cd	12.22(12)	20600(400) b	19560(250) b	19560(250) b	1970(30) b	9042.7(3)	9043.18(6)
114Cd(0)	28.73(42)	300(20) mb				6140.9(6)	
114Cd(181)		36(7) mb					
116Cd(0)	7.49(18)	50(8) mb				5777.2(10)	
116Cd(136)		25(10) mb					
113In(0)	4.29(5)	3.9(4) b	6.2(12) b	15.0(18) b	0.92(7) b	7274.4(12)	7273.83(23)
113In(190)		8.1(8) b	8.2(13) b				
113In(502)		3.1(7) b	0.63(21) b				
115In(0)	95.71(5)	40(2) b	42(3) b	190(7) b	7.27(21) b	6784.3(8)	6784.72(17)
115In(127)		162.3(7) b	88(4) b				
115In(290)		81(8) b	60(4) b				
112Sn	0.97(1)	860(90) mb				7742.9(18)	
112Sn(77)		300(40) mb					
114Sn	0.66(1)	120(30) mb				7545.7(16)	
115Sn	0.34(1)	30(7) b	58.0(8) b	12.5(4) b		9563.41(11)	9563.55(3)
116Sn(0)	14.54(9)	130(30) mb	154 mb 3	154(3) mb	6.7(14) mb	6944.5(11)	6942.9(5)
116Sn(314)		6(2) mb					
117Sn	7.68(7)	1.32(18) b	1.045(18) b	1.045(18) b	0.027(3) b	9326.3(14)	9327.9(11)

Isotope and (E), (mode)	Percent Abundance ⁸	σ_{γ} (mb or b)			Sn (keV)		
		Mughabghab ¹⁻³	This work	Secondary	Primary	Audi ⁴	This work
118Sn	24.22(9)	220(50) mb	83(3) mb	83(3) mb	3(1) mb	6585.2(14)	6483.3(6)
118Sn(90)		10(6) mb					
119Sn	8.59(4)	2.2(5) b	1.134(16) b	1.134(16) b	0	9107.2(22)	
120Sn(0)	32.58(9)	140(30) mb	118(8) mb	118(8) mb	4(1) mb	6170.8(6)	6170.1(4)
120Sn(6)		1(1) mb	1.9(4) mb				
122Sn(0)	4.63(3)	1 mb 1				5946.0(12)	
122Sn(25)		138(15) mb	126(4) mb	79(6) mb	0		
124Sn(0)	5.79(5)	4(2) mb	13(2) mb	13(2) mb	0	5733.0(5)	
124Sn(28)		130(5) mb	148(3) mb				
121Sb	57.21(5)	5.9(2) b	8.0(11) b	8.0(11) b	0.74(2) b	6806.6(10)	6806.36(7)
121Sb(164)		60(10) mb	49(10) mb				
123Sb(0)	42.79(5)	4.1(1) b	3.14(25) b	4.19(26) b	0.68(3) B	6467.45(7)	6467.58(5)
123Sb(11)		37(10) mb	740(80) mb				
123Sb(37)		19(10) mb	310(16) mb				
120Te(0)	0.09(1)	2.0(3) B				7230(30)	
120Te(294)		340(60) mb					
122Te	2.55(12)	3.9(5) b	1.49(9) b	1.49(9) b	0.88(10) b	6939.4(25)	6929.16(10)
122Te(248)		1.1(5) b	300(30) mb				
123Te	0.89(3)	418(30) b	339(18) b	339(18) b	49(2) b	9424.1(12)	9423.89(7)
124Te	4.74(14)	6.8(13) b	7.73(25) b	7.73(25) b	4.18(20) b	6575.9(14)	6569.39(14)
124Te(145)		40(25) mb	770(70) mb				
125Te	7.07(15)	1.55(16) b	0.70(7) b	0.70(7) b	0	9113.8(4)	
126Te(0)	18.84(25)	900(150) mb	28(7) mb	28(7) mb	12(4) mb	6291(3)	6287.8(4)
126Te(88)		135(23) mb					
128Te(0)	31.74(8)	200(8) mb	195(9) mb	157(10) mb	195(9) mb	6083(3)	6082.36(14)
128Te(106)		15(1) mb	29.0(22) mb				
130Te(0)	34.08(62)	270(6) mb	132(10) mb	132(10) mb	79(9) mb	5929.7(5)	5930.16(15)
130Te(182)		20(10) mb					
127I	100	6.2(2) b	4.4(3) b	4.4(3) b	0.98(5) b	6826.07(5)	6826.215(4)

Isotope and (E), (mode)	Percent Abundance ⁸	σ_{γ} (mb or b)			Sn (keV)		
		Mughabghab ¹⁻³	This work	Secondary	Primary	Audi ⁴	This work
124Xe	0.09(1)	165(20) b	11(2) b	11(2)	0	7603.3(4)	
124Xe(253)		28(5) b	5.0(5) b				
126Xe	0.09(1)	3.8(5) b				7223(6)	
126Xe(297)		450(130) mb					
128Xe	1.92(3)	5.2(13) b	1.23(15) b	1.23(15) b	0.57(12) b	6907.6(16)	
128Xe(236)		480(100) mb	190(40) mb				
129Xe	26.44(24)	21(5) b	7.2(9) b	7.2(9) b	1.95(14) b	9255.2(9)	9255.57(23)
130Xe	4.08(2)	4.8(12) b	0.76(9) b	0.76(9) b	0.23(6) b	6605.2(19)	
130Xe(164)		450(100) mb					
131Xe	21.18(3)	85(10) b	35.7(24) b	35.7(24) b	10.7(9) b	8936.0(9)	8936.65(12)
132Xe	26.89(6)	415(50) mb				6440(4)	
132Xe(233)		50(10) mb					
134Xe	10.44(10)	265(20) mb				8548(4)	
134Xe(527)		3.0(3) mb					
136Xe	8.87(16)	260(20) mb	130(30) mb	130(30) mb	102(16) mb	4025.5(3)	4025.53(8)
133Cs	100	30.3(11) b	23.3(7) b	23.3(7) b	3.58(8) b	6891.540(10)	6891.3909(23)
133Cs(139)		2.5(2) b	2.47(4) b				
130Ba(0)	0.106(1)	8.7(9) b				6493.5(3)	
130Ba(187)		2.5(3) b	4.4(4) b				
132Ba(0)	0.101(1)	6.5(8) b				7189.9(4)	
132Ba(288)		500(200) mb					
134Ba	2.417(18)	1.5(3) b	1.07(4) b	1.07(4) b	0.457(17) b	6971.97(12)	6971.87(12)
134Ba(268)		158(24) mb	46(3) mb				
135Ba	6.592(12)	5.8(9) b	4.02(7) b	4.02(7) b	0.69(6) b	9107.74(4)	9107.73(4)
135Ba(2030)		13.9(7) mb	35(15) mb				
136Ba	7.854(24)	680(170) mb	735(24) mb	735(24) mb	613(19) mb	6905.76(3)	6905.74(8)
136Ba(662)		10(1) mb	20(4) mb				
137Ba	11.232(24)	3.6(2) b	4.06(8) b	4.06(8) b	2.05(3) b	8611.72(4)	8611.63(5)
138Ba	71.698(42)	400(40) mb	435(12) mb	435(12) mb	366(10) mb	4723.43(4)	4723.20(10)

Isotope and (E), (mode)	Percent Abundance ⁸	σ_{γ} (mb or b)			Sn (keV)		
		Mughabghab ¹⁻³	This work	Secondary	Primary	Audi ⁴	This work
138La	0.090(1)	57(6) b	57(6) b	57(6) b	10(3) b	8778(3)	
139La	99.910(1)	9.04(4) b	6.13(24) b	6.13(24) b	5.76(5) b	5160.97(5)	5161.004(6)
136Ce(0)	0.185(2)	6.5(10) b	3.8(4) b	3.8(4) b	0.070(6) b	7480.7(4)	7481.58(9)
136Ce(254)		950(250) mb	200(60) mb				
138Ce(0)	0.251(2)	1.00(24) b	6.1(4) b	6.1(4) b	0.87(12) b	7456(12)	
138Ce(754)		15 mb 5					
140Ce	88.450(51)	580(20) mb	284(17) mb	284(17) mb	250(10) mb	5428.6(7)	5428.19(6)
142Ce	11.114(51)	970(20) mb	732(23) mb	732(23) mb	422(20) mb	5145.1(3)	5144.81(6)
141Pr	100	11.5(3) b	7.72(15) b	7.72(15) b	3.65(4) b	5843.06(10)	5843.155(5)
141Pr(3.7)		3.9(3) b	3.45(13) b				
142Nd	27.2(5)	18.7(7) b	17.6(15) b	17.6(15) b	7.8(4) b	6123.59(13)	6123.41(7)
143Nd	12.2(2)	325(10) b	288(19) b	288(19) b	38(2) b	7817.02(7)	7816.94(17)
144Nd	23.8(3)	3.6(3) b	5.3(3) b	5.3(3) b	2.02(18) b	5755.5(6)	5755.26(22)
145Nd	8.3(1)	42(2) b	39.9(10) b	39.9(10) b	18.8(6) b	7565.25(14)	7565.05(9)
146Nd	17.2(3)	1.41(5) b	1.21(11) b	1.21(11) b	0.178(6) b	5292.07(15)	5292.19(4)
148Nd	5.7(1)	2.58(14) b	1.9(3) b	1.9(3) b	0.37(6) b	5038.68(10)	5038.82(3)
150Nd	5.6(2)	1.03(8) b	1.8(5) b	1.8(5) b	0.6(1) b	5334.43(20)	5334.552(24)
144Sm	3.07(7)	1.64(10) b				6757.1(3)	
147Sm	14.99(18)	57(3) b	67(4) b	67(4) b	338(17) b	8141.5(6)	8141.3(3)
148Sm	11.24(10)	2.4(6) b				5871.6(9)	
149Sm	13.82(7)	40140(600) b	37970(150) b	37970(150) b	18223(70) b	7985.7(7)	7986.7(4)
150Sm	7.38(1)	100(4) b	105(8) b	105(8) b	46(2) b	5596.44(10)	5596.44(6)
152Sm	26.75(16)	206(6) b	167(10) b	167(10) b	36(2) b	5867.73(23)	5868.40(10)
154Sm	22.75(29)	8.3(5) b		8.4(9) b	0	5807.2(3)	
151Eu(0)	47.81(3)	5900(200) b	6700(300) b	6700(300) b	243(9) b	6306.72(10)	6307.11(6)
151Eu(46)		3300(200) b	4500(2200) b				
151Eu(148)		4(2) b					
153Eu	52.19(3)	312(7) b	387(70) b	387(70) b	18(5) b	6442.0(3)	6442.2(4)
152Gd	0.20(1)	735(20) b	>370 b	734(30) b	46(3) b	6247.3(3)	6247.48(17)

Isotope and (E), (mode)	Percent Abundance ⁸	σ_{γ} (mb or b)			Sn (keV)		
		Mughabghab ¹⁻³	This work	Secondary	Primary	Audi ⁴	This work
154Gd	2.18(3)	85(12) b		85(7) b	17(1) b	6435.1(3)	6435.29(19)
154Gd(122)		49(15) mb					
155Gd	14.80(12)	60900(500) b	51700(1800) b	51700(1800) b	8680(400) b	8536.37(12)	8536.04(9)
156Gd	20.47(9)	1.8(7) b				6360.05(15)	
157Gd	15.65(2)	254000(800) b	210000(5000) b	210000(5000) b	41000(500) b	7937.33(12)	7937.39(5)
158Gd	24.84(7)	2.2(2) b				5943.29(15)	
160Gd	21.86(19)	1.4(3) b				5635.4(10)	
159Tb	100	23.3(4) b	30(3) b	30(3) b	2.09(7) b	6375.2(3)	6375.13(7)
156Dy	0.06(1)	33(3) b				6969(6)	
158Dy	0.10(1)	43(6) b				6831.5(24)	
160Dy	2.34(8)	55(3) b	2910 b 200	56(4) b	66(4) b	6454.36(9)	6454.34(6)
161Dy	18.91(24)	600(25) b	560(15) b	560(15) b	9(2) b	8196.95(12)	8193(3)
162Dy	25.51(26)	194(10) b	154(6) b	154(6) b	44(4) b	6270.93(7)	6271.14(3)
163Dy	24.90(16)	134(7) b	68(8) b	68(8) b	5.0(4) b	7658.08(12)	7655.0(9)
164Dy(0)	28.18(37)	1040(140) b	770(50) b	770(50) b	696(15) b	5715.89(10)	5715.95(3)
164Dy(108)		1610(240) b	1514(40) b				
165Ho(0)	100	61.2(11) b	52.8(13) b	54.6(13) b	9.82(14) b	6243.640(20)	6243.677(6)
165Ho(6)		3.5(4) b	1.85(11) b				
162Er	0.14(1)	19(2) b				6903(5)	
164Er	1.61(3)	13(2) b				6650.0(7)	
166Er	33.61(35)	16.9(16) b	20.8(14) b	20.8(14) b	9.8(8) b	6436.1(4)	6436.46(18)
166Er(208)		15(2) b	11.6(13) b				
167Er	22.93(17)	649(8) b	688(30) b	688(30) b	271(7) b	7771.07(25)	7771.45(3)
168Er	26.78(26)	2.74(8) b	17.4(24) b	17.4(24) b	8.3(9) b	6003.1(3)	6003.16(14)
170Er	14.93(27)	8.85(30) b	5.5(10) b	5.5(10) b	4.0(6) b	5681.5(5)	5681.6(5)
169Tm	100	92(4) b	110.7(12) b	110.7(12) b	16.2(4) b	6593.3(11)	6591.95(11)
169Tm(183)		8.2(17) b	2.3(7) b				
168Yb	0.13(1)	2300(170) b	1640(160) b	1640(160) b	149(18) b	6867.2(3)	6866.97(11)
170Yb	3.04(15)	9.9(18) b	18(3) b	18(3) b	1.8(3) b	6614.8(7)	6616.6(4)

Isotope and (E), (mode)	Percent Abundance ⁸	σ_{γ} (mb or b)			Sn (keV)		
		Mughabghab ¹⁻³	This work	Secondary	Primary	Audi ⁴	This work
171Yb	14.28(57)	58(4) b	50(7) b	50(7) b	3.63(18) b	8019.7(3)	8019.27(4)
172Yb	21.83(67)	1.3(8) b	0.92(10) b	0.92(10) b	0.18(2) b	6367.6(5)	6367.2(6)
173Yb	16.13(27)	15.5(15) b	25(3) b	25(3) b	0.97(11) b	7464.60(10)	7465.5(4)
174Yb	31.83(92)	63.2(15) b	55(8) b	55(8) b	13.5(21) b	5822.33(12)	5822.5(4)
175Yb(515)			40(8) b				
176Yb	12.76(41)	2.85(5) b	0.39(4) b	0.39(4) b	0.24(3) b	5566.8(12)	5566.40(19)
176Yb(332)			300(30) mb				
175Lu(0)	97.41(2)	6.9(13) b	2.71(22) b	23.5(10) b	1.05(7) b	6287.98(15)	6289.78(20)
175Lu(123)		16.2(5) b	20.8(10) b				
176Lu	2.59(2)	2090(70) b	1864(30) b	1864(30) b	222(6) b	7072.2(7)	7072.85(9)
176Lu(150)		317(58) b	597(17) b				
176Lu(970)		2.8(7) b					
174Hf	0.16(1)	549(7) b	411(7) b	411(7) b	72(6) b	6708.7(5)	6708.8(6)
176Hf	5.26(7)	24(3) b	24.8(15) b	24.8(15) b	4.4(8) b	6378.8(15)	6385.8(8)
177Hf	18.60(9)	373(10) b	450(30) b	450(30) b	25.3(10) b	7626.3(3)	7625.80(16)
177Hf(1147)		960(50) mb	790(180) mb				
177Hf(2446)		0.2(1) mb					
178Hf	27.28(7)	84(4) b	105(5) b	105(5) b	34.9(11) b	6099.03(10)	6098.946(22)
178Hf(375)		53(6) b	69(4) b				
179Hf	13.629(6)	41(3) b	39.2(21) b	39.2(21) b	14.7(8) b	7388.2(4)	7387.85(9)
179Hf(1142)		445(3) mb					
180Hf	35.08(16)	13.04(7) b	12.2(13) b	12.2(13) b	8.9(8) b	5695.7(7)	5695.58(17)
180Ta	0.012(2)	563(60) b				7577.0(13)	
181Ta(0)	99.988(2)	20.5(5) b	9.01(22) b	9.01(22) b	1.54(3) b	6062.96(16)	6062.89(6)
181Ta(520)		11(2) mb					
180W	0.12(1)	<150 b	19.3(18) b	19.3(18) b	0	6681(6)	
182W	26.50(16)	19.9(2) b	12.6(5) b	12.6(5) b	4.66(20) b	6190.7(10)	6190.89(3)
182W(309)			88(18) mb				
183W	14.31(4)	10.3(2) b	7.21(17) b	7.21(17) b	4.12(11) b	7411.7(3)	7411.15(7)

Isotope and (E), (mode)	Percent Abundance ⁸	σ_{γ} (mb or b)			Sn (keV)		
		Mughabghab ¹⁻³	This work	Secondary	Primary	Audi ⁴	This work
184W	30.64(2)	1.7(1) b	2.0(4) b	2.0(4) b	1.58(21) b	5753.7(3)	5754.62(21)
184W(197)		2(1) mb					
186W	28.42(19)	38.5(5) b	20.3(3) b	20.3(3) b	14.21(24) b	5466.72(21)	5466.59(6)
185Re	37.40(2)	112(2) b	113(12) b	113(12) b	17.6(5) b	6179.7(7)	6179.34(13)
187Re	62.60(2)	76.4(5) b	79(10) b	79(10) b	7.16(24) b	5871.6(3)	5871.75(6)
187Re(172)		2.8(1) b	1.73(18) b				
184Os	0.02(1)	3000(150) b	4410(60) b	4410(60) b	1175(80) b	6625.4(9)	6624.52(25)
186Os	1.59(3)	80(13) b	16.4(16) b	16.4(16) b	3.3(5) b	6292.6(13)	6289.4(8)
187Os	1.96(2)	245(40) b	169(3) b	169(3) b	45.9(13) b	7989.3(3)	7989.58(7)
188Os	13.24(8)	4.7(5) b	5.5(11) b	5.5(11) b	2.4(3) b	5920.6(5)	5922.0(4)
189Os	16.15(5)	25(4) b	25.1(5) b	25.1(5) b	4.56(18) b	7791.6(9)	7792.31(11)
189Os(1705)		0.26(3) mb					
190Os(0)	26.26(2)	3.9(6) b	0.85(4) b	17.5(11) b	3.11(12) b	5758.67(16)	5758.81(9)
190Os(74)		9.2(7) b	16.6(11) b				
192Os	40.78(19)	3.12(16) b	2.69(12) b	2.69(12) b	0.83(5) b	5585.1(9)	5584.01(12)
191Ir(0)	37.3(2)	309(30) b	630(70) b	1080(70) b	154(3) b	6198.08(20)	6198.14(3)
191Ir(57)		645(32) b	450(20) b				
191Ir(155)		160(70) mb					
193Ir	62.7(2)	111(5) b	97(17) b	97(17) b	23.0(4) b	6066.8(4)	6066.71(7)
193Ir(112+y)		5.8(2) b					
190Pt	0.014(1)	122(4) b				6437(6)	
192Pt	0.782(7)	10.0(25) b				6255.5(19)	
192Pt(150)		2.2(8) b					
194Pt	32.967(99)	580(190) mb	745(25) mb	745(25) mb	231(22) mb	6105.06(12)	6109.17(4)
194Pt(259)		98(11) mb	65(4) mb				
195Pt	33.832(10)	28.5(12) b	22.37(22) b	22.37(22) b	8.25(21) b	7921.88(15)	7921.92(7)
196Pt(0)	25.242(41)	410(40) mb	550(40) mb		630(30) mb	5846.4(3)	5846.0(7)
196Pt(400)		44(4) mb					
198Pt	7.163(55)	3.66(19) b	2.69(12) b			5556.1(5)	

Isotope and (E), (mode)	Percent Abundance ⁸	σ_{γ} (mb or b)			Sn (keV)		
		Mughabghab ¹⁻³	This work	Secondary	Primary	Audi ⁴	This work
198Pt(424)		350(40) mb					
197Au	100	98.65(9) b	108(5) b	108(5) b	12.8(5) b	6512.17(22)	6512.32(10)
196Hg(0)	0.15(1)	3080(180) b	1240(120) b	1240(120) b	578(50) b	6785.4(15)	
196Hg(299)		109(6) b					
198Hg	9.97(20)	2.0(3) b				6664.0(6)	
198Hg(532)		18(4) mb					
199Hg	16.87(22)	2150(50) b	2215(30) b	2215(30)	1571(14)	8028.26(25)	8028.37(4)
200Hg	23.10(19)	<60 b				6230.2(6)	
201Hg	13.18(9)	5.7(12) b	4.9(6) b	4.9(6) b	2.17(13) b	7754.31(23)	7753.93(15)
202Hg	29.86(26)	4.42(7) b				5992.9(17)	
204Hg	6.87(15)	430(100) mb				5668(4)	
203Tl	29.524(14)	11.4(2) b	12.09(12) b	12.09(12) b	10.58(9) b	6655.8(3)	6654.88(4)
205Tl	70.476(14)	104(17) mb	101(3) mb	101(3) mb	44(4) mb	6503.7(4)	6502.87(24)
204Pb	1.4(1)	660(70) mb	397(11) mb	388(7) mb	419(11) mb	6731.50(15)	6731.80(9)
206Pb	24.1(1)	26.6(12) mb	29.2(8) mb	29.5(8)	28.9(8)	6737.79(11)	6737.74(10)
206Pb(1633)		6.3(13) mb					
207Pb	22.1(1)	620(14) mb	622(14) mb	622(14) mb	622(14) mb	7367.82(9)	7367.92(7)
208Pb	52.4(1)	0.23(3) mb				3935.9(13)	
209Bi(0)	100	24.2(4) mb	21.3(23) mb	21.3(23) mb	61(3) mb	4604.58(13)	4604.63(5)
209Bi(271)		9.6(8) mb	17(6) mb				
232Th	100	7.35(3) b	9.5(12) b	9.5 (12) b	0.91(2) b	4786.35(25)	4786.34(3)
234U	0.0055(5)	99.8(13) b				5297.84(23)	
235U	0.7200(51)	98.3(8) b	28 b	28 b	0.44(6) b	6544.8(5)	
238U	99.274(11)	2.68(19) b	2.34(4) b	2.3(4) b	0.491(12) b	4806.26(21)	

Note: y in 193Ir(112+y) means that the absolute isotope level energy is not known but is above 112 keV by some value y.

Table 5.2 Comparison of thermal neutron-capture cross-section measurements on ^{12}C with the value adopted by Mughabghab [5.1] and the results of this evaluation.

Measurement Method	^{12}C Cross Section (millibarns)	Reference
Diffusion length	3.44 ± 0.8	Hendrie [5.9]
Mass spectrometry	3.30 ± 0.15	Henning [5.10]
Pile oscillator	3.5 ± 0.3	Muehlhause [5.11]
Pile oscillator	3.65 ± 0.15	[5.12]
Pile oscillator	3.85 ± 0.15	Koechlin [5.13]
Pulsed neutrons	3.72 ± 0.15	Sagot [5.14]
Pulsed neutrons	3.83 ± 0.06	Starr [5.15]
Reactivity	3.57 ± 0.03	Nichols [5.16]
Capture	3.8 ± 0.4	Journey [5.17]
Capture	3.53 ± 0.07	Journey [5.18]
Capture	3.50 ± 0.16	Prestwich [5.19]
Adopted value	3.53 ± 0.07 mb	Mughabghab [5.1]
This work	3.89 ± 0.06 mb	

Table 5.3 Nitrogen thermal neutron-capture cross-section measurements measured by the capture gamma-ray level scheme intensity balance. Column 1 shows the comparator standard that was used; column 2 lists the reported capture cross section; and column 3 gives the cross section renormalized to the new adopted standard value [5.1].

Cross Section σ_γ (millibarns)			
Standard	Measured	Renormalized	Reference
^{12}C (3.53 ± 0.07)	79.7 ± 2.4	79.7 ± 2.4	Islam [5.22]
^{35}Cl (43.6 ± 0.4 b)	80.1 ± 2.0	80.0 ± 2.0	Islam [5.22]
^{207}Pb (712 ± 10)	79.6 ± 1.6	69.3 ± 1.4	Islam [5.22]
^{27}Al (230 ± 3)	76.7 ± 2.7	77.0 ± 2.7	Islam [5.23]
^{35}Cl (43.6 ± 0.5 b)	79.7 ± 2.4	79.6 ± 2.4	Islam [5.23]
^1H (332 ± 2)	75.0 ± 7.5	75.1 ± 7.5	Journey[5.17]
Adopted Value	79.8 ± 1.4 mb		Mughabgab[5.1]
This work	79.0 ± 0.9 mb		

6. DATA SOURCES AND EVALUATION METHODOLOGY

R.B. Firestone, G.L. Molnár, Zs. Révay

6.1. Prompt gamma-ray source databases

Four primary databases were used in this evaluation.

6.1.1. *Lone database*

Database of Lone et al [6.1] was based primarily on measurements of elemental spectra by Orphan and Rasmussen using small Ge(Li) detectors [6.2, 6.3]. These data were not constrained by nuclear structure information, so the gamma-ray assignments were often unreliable.

6.1.2. *ENSDF database*

Evaluated Nuclear Structure Data File (ENSDF) is a comprehensive nuclear structure and decay database evaluated internationally under the auspices of the IAEA Nuclear Structure and Decay Data Evaluators Network [6.4]. ENSDF contains experimental data compiled from literature sources and organized by isotope with separate datasets for each reaction type including thermal neutron capture. Intensity data are generally normalized per 100 neutron captures. Primary emphasis of ENSDF evaluations is the determination of nuclear structure properties, i.e., these datasets were not evaluated for use in applications. ENSDF capture gamma-ray datasets are often intermixed with information from epithermal reactions, and sometimes the gamma-ray intensity scale has multiple normalization factors for different energy regions. Updated ENSDF datasets for $A = 1 - 44$ and some nuclides with $A > 190$ were provided by Chunmei [6.5-6.8]. The primary ENSDF thermal neutron capture gamma-ray literature references are listed in Appendix B.

6.1.3. *Reedy and Frankle database*

The database of Reedy and Frankle encompasses essentially the same literature as ENSDF for the isotopes of elements from $Z = 1-30$ [6.9, 6.10]. These data are normalized per 100 neutron captures, but have been carefully evaluated for use in various important applications.

6.1.4. *Budapest database*

The largest amount of new data and the only complete source of radiative neutron capture gamma-ray cross sections came from the Institute of Isotope and Surface Chemistry, Budapest, Hungary. Neutron capture reactions on all naturally occurring elements except four noble gases (He, Ne, Ar, Kr), i.e., 79 elements from H to U, were studied on the PGAA guided thermal-neutron beam facility of the Budapest Research Reactor.

Capture gamma ray spectra were measured with natural targets using a Compton suppression spectrometer [6.11]. All elemental targets were measured together with a chlorine target in order to achieve a consistent energy calibration. The precise energies of two peaks from the $^{35}\text{Cl}(n, \gamma)$ reaction [6.12] were used to determine the energies of two distinct peaks, which were then used for the energy calibration of elemental spectra after non-linearity correction. The accurate new energy and intensity data were sufficient to identify over 13,000 gamma rays from 79 elements. The data for transitions with cross sections greater than 5% of the largest cross section for each element are reported in Appendix A, and the complete Budapest measurements are included on the accompanying CD-ROM.

Measurements with composite targets (stoichiometric compounds, mixtures, or solutions) yielded accurate normalizing factors, with respect to the $H(n, \gamma)$ cross section, by means of internal k_0 standardization [6.13]. Thus, very accurate determinations of the partial gamma-ray production cross sections and related k_0 -factors became possible. Energies and k_0 -factors for the most important gamma lines have been published [6.14, 6.15], and the data library has been discussed in Refs. [6.16-6.18]. Partial cross sections and k_0 -factors for the best lines for each element were remeasured [6.19], often with several targets, and complemented with gamma-rays from short-lived decay products [6.20], as summarized in Table 6.1.

Table 6.1. Partial γ -ray cross sections for the elements as measured by internal standardization at the Budapest thermal guide [6.19]. Decay gamma rays are denoted by d in the energy column.

Z	El	E γ -keV	$\sigma_\gamma^z(E\gamma)$ -barns	Z	El	E γ -keV	$\sigma_\gamma^z(E\gamma)$ -barns
1	H	2223.2590(10)	0.3326(7)	45	Rh	470.41(3)	2.50(7)
3	Li	2032.300(20)	0.038(1)	46	Pd	616.219(15)	0.638(6)
4	Be	6809.58(10)	0.0054(5)	47	Ag	657.741(22)	1.93(4)
5	B	478(3)	713(5)	48	Cd	558.32(3)	1866(21)
6	C	1261.71(6)	0.00120(2)	49	In	5892.38(15)	2.1(2)
		4945.30(7)	0.00262(3)	50	Sn	1293.53(6)	0.134(2)
7	N	1884.85(3)	0.01458(6)	51	Sb	921.04(4)	0.086(4)
8	O	870.68(3)	0.000175(8)	52	Te	602.723(12)	2.4(2)
9	F	1633.53(3)d	0.0093(3)	53	I	133.59(4)	1.42(5)
11	Na	472.222(13)	0.497(5)	54	Xe	667.87(9)	6.9(10)
12	Mg	584.936(24)	0.0327(7)	55	Cs	5505.46(20)	0.306(4)
13	Al	1778.92(3)d	0.233(4)	56	Ba	1435.65(6)	0.308(6)
14	Si	3538.98(5)	0.119(2)	57	La	567.413(23)	0.333(7)
15	P	636.570(17)	0.031(1)	58	Ce	662.03(5)	0.233(18)
16	S	841.013(14)	0.357(7)	59	Pr	176.95(3)	1.06(2)
17	Cl	1951.150(15)	6.51(4)	60	Nd	696.487(20)	33.2(7)
19	K	770.325(23)	0.91(2)	62	Sm	334.02(5)	4900(60)
20	Ca	1942.68(3)	0.34(1)	63	Eu	89.97(8)	1450(20)
21	Sc	584.80(3)	1.83(3)	64	Gd	182.12(6)	7680(170)
22	Ti	1381.74(3)	5.18(5)	65	Tb	74.89(8)	0.35(4)
23	V	1434.10(3)d	5.2(1)	66	Dy	184.34(7)	146(3)
24	Cr	834.80(3)	1.38(2)	67	Ho	136.67(4)	14.5(7)
25	Mn	846.829(1)d	13.3(2)	68	Er	184.301(25)	57(2)
26	Fe	7631.05(9)	0.68(1)	69	Tm	204.41(5)	8.7(1)
27	Co	229.811(12)	7.18(7)	70	Yb	639.73(3)	1.5(1)
28	Ni	464.972(18)	0.843(9)	71	Lu	150.34(6)	13.7(4)
29	Cu	277.993(25)	0.893(9)	72	Hf	213+214	1.97(4)
30	Zn	1077.336(17)	0.358(4)	73	Ta	270.48(6)	2.60(4)
31	Ga	690.943(24)	0.26(3)	74	W	145.74(9)	0.97(2)
32	Ge	595.879(20)	1.59(4)	75	Re	207.92(4)	4.5(2)
33	As	165.09(3)	1.00(1)	76	Os	186.85(3)	2.08(4)
34	Se	6600.67(12)	0.57(3)	77	Ir	351.59(5)	2.42(8)
35	Br	1248.78(12)	0.054(1)	78	Pt	355.54(4)	6.17(5)
37	Rb	556+557	0.132(2)	79	Au	215.01(3)	7.77(5)
38	Sr	1836.05(3)	1.02(1)	80	Hg	5967.00(10)	53(2)
39	Y	6080.12(7)	0.85(2)	81	Tl	873.16(8)	0.168(6)
40	Zr	213+214	0.125(6)	82	Pb	7367.83(12)	0.137(3)
41	Nb	499.48(3)	0.065(5)	83	Bi	319.83(4)	0.017(2)
42	Mo	778.221(10)	2.04(5)	90	Th	256.25(11)	0.093(4)
44	Ru	539.522(11)	1.5(1)	92	U	4060.35(5)	0.186(3)

6.2. Evaluation databases

Two ENSDF-formatted datasets were created for each isotope, one from the Budapest experimental data, and another combining isotopic data from the above sources. The Budapest measurements were elemental, and gamma rays were assigned to an isotope and placed in the level scheme by comparing the energies and relative intensities with those in ENSDF. Additional, new gamma-ray placements were determined for some transitions by comparing the experimental data with the ENSDF Adopted Levels, and Gammas dataset. The gamma-ray energies and intensities from the literature and experimental datasets were then averaged to determine the adopted energies and cross sections.

The isotopic ENSDF database combines data from ENSDF, Reedy and Frankle, and additional references retrieved from the Nuclear Sciences Reference file (NSR) [6.21]. This dataset was evaluated further for the consistency of the normalization factors and the completeness of the data. Additional gamma-ray branches, internal conversion coefficients and other data were added from the ENSDF Adopted Levels and Gammas dataset.

6.3. Adopted gamma-ray energies

Gamma-ray energies were determined by a weighted least-squares fit of both the isotopic and experimental database gamma-ray energies to the level energies. Since the adopted gamma-ray energies are the level energy differences after correction for recoil, weak transitions could be determined to good precision. A chi-squared analysis was performed by comparing the input to the adopted data, and the uncertainties of individual outliers with $\chi^2/f > 4$ and/or all data in datasets with $\chi^2/f > 1$ were increased and the fit repeated until $\chi^2/f = 1$. Badly discrepant outliers were discarded, particularly when more accurate data were available. A typical fit of gamma-ray energies is shown in Table 6.2 for $^{24}\text{Mg}(n, \gamma)$.

6.4. Adopted gamma-ray cross sections

Measured experimental gamma-ray intensities were reported as elemental cross sections, whereas the corresponding literature values were typically compiled per 100 neutron captures of the isotope. These data were averaged by one of two methods:

- If a well-defined gamma-ray cross section existed in the literature, the gamma-ray intensities in the literature dataset were renormalized to that value, converted to an elemental cross section by means of the isotopic abundance [6.22], and averaged with the experimental values.
- If no precise normalization factor existed for most cross sections, the intensities in the literature dataset were renormalized by a factor chosen to minimize the weighted average difference between the literature and experimental intensity data. The renormalized intensities were then averaged with the experimental data to obtain the adopted cross sections.

A similar chi-squared analysis to that described for the energies was performed to handle outliers and discrepant data. The skew in the chi-squared distribution as a function of energy was used to probe systematic differences in the underlying efficiency curves, and discrepant data were adjusted or removed as necessary. A typical fit of gamma-ray intensities is shown in Table 6.3 for $^{24}\text{Mg}(n, \gamma)$.

Table 6.2 First iteration of a least squares fit of gamma-ray energies to the level scheme for $^{24}\text{Mg}(n, \gamma)$. Numbers in parentheses represent the discrepancy in the number to the right,

compared to the adopted value, expressed in terms of the number of standard deviations. The uncertainties in each dataset were increased and additional iterations were performed until $\chi^2/f = 1$.

FITTED LEVEL ENERGIES – ²⁴Mg

1.	0.0		7.	3413.341	23
2.	585.001	16	8.	4276.32	3
3.	974.689	18	9.	4358.2	5
4.	1964.69	9	10.	5116.36	14
5.	2563.32	3	11.	7330.52	3
6.	2801.53	9			

	ENSDF	BUDAPEST	ADOPTED	Level-1	Level-2
	389.69 5	(1) 389.64 3	389.685 18	3	2
(2)	585.06 3	(2) 584.936 24	584.994 16	2	1
	611.8 10		611.80 9	7	6
(1)	836.95 10)	836.75 8	836.82 6	6	4
	849.9 3	849.93 16	850.01 3	7	5
(2)	863.09 5	(2) 862.88 4	862.962 23	8	7
(3)	974.84 5	(1) 974.61 3	974.669 18	3	1
	989.7 4		989.98 9	4	3
	1379.7 3	1379.69 19	1379.65 9	4	2
	1448.7 10		1448.61 9	7	4
	1474.8 10		1474.74 9	8	6
	1588.65 9	(1) 1588.40 9	1588.58 3	5	3
	1702.6 7		1702.96 14	10	7
	1713.05	(1) 1712.85 6	1712.94 3	8	5
	1964.7 4	1964.63 25	1964.61 9	4	1
	1978.25 5	(1) 1978.14 8	1978.24 3	5	2
	2213.8 5	2214.29 25	2214.05 14	11	10
	2216.5 6	2216.8 4	2216.42 9	6	2
(1)	2438.48 4	(1) 2438.42 9	2438.524 22	7	3
	2553.7 8		2552.90 14	10	5
	2563.6 5		2563.18 3	5	1
(1)	2801.0 3	2801.5 4	2801.36 9	6	1
(1)	2828.21 4	2828.12 10	2828.168 22	7	2
	2972.4 8		2972.2 5	11	9
	3053.99 4	(1) 3053.85 12	3054.00 3	11	8
	3301.42 5	3301.29 13	3301.40 3	8	3
(1)	3413.15 5	3413.04 14	3413.091 23	7	1
	3691.07	3690.98 18	3691.03 3	8	2
	3916.86 4	(1) 3916.65 16	3916.85 3	11	7
	4141.4 3	4141.38 24	4141.31 14	10	3
		4357.9 6	4357.8 5	9	1
	4528.47	4528.66 22	4528.55 9	11	6
	4766.86	4766.68 25	4766.71 4	11	5
	6355.02	6354.9 3	6354.96 3	11	3
(1)	6744.9 3		6744.54 3	11	2
(1)	7330.6 9		7329.37 3	11	1

ENSDF: $\chi^2/f = 1.561$, $f = 25$; Budapest: $\chi^2/f = 1.907$, $f = 17$

Total $\chi^2/f = 1.429$ (fit of 61 gamma transitions to 10 levels)

Table 6.3 First iteration of a least squares fit of gamma-ray intensities for $^{24}\text{Mg}(n, \gamma)$. Numbers between asterisks represent the discrepancy in the data to the left expressed in terms of the number of standard deviations. The uncertainties in each dataset were increased and additional iterations were performed until $\chi^2/f = 1$. Fitted cross sections from the Budapest reactor measurements were adopted.

E_γ	I_γ -ENSDF		σ_γ -Budapest		Relative I_γ
	$I_\gamma(\text{input})$	$I_\gamma(\text{fit})$	input	fit	
389.670 21	7.5 4	7.4 3	0.0058 3	0.00585 24	18.3 7
585.00 3	39.8 12	39.9 11	0.0316 15	0.0314 11	98.1 25
611.81 9	0.015 15	0.015 15		1.2E-05 12	0.04 4
836.83 6	0.21 3	0.200 19	1.52E-04 18	1.57E-04 15	0.49 5
849.99 4	0.070 20	0.084 14	7.2E-05 15	6.6E-05 11	0.21 4
862.96 3	0.48 5	0.52 3	0.000420 25	0.000410 21	1.28 7
974.66 3	8.3 4	8.4 3	0.0067 3	0.00662 24	20.7 7
989.99 10	0.050 10	0.050 10		3.9E-05 8	0.123 25
1379.64 9	0.100 20	0.107 14	8.8E-05 14	8.4E-05 11	0.26 3
1448.62 10	0.015 15	0.015 15		1.2E-05 12	0.04 4
1474.75 10	0.015 15	0.015 15		1.2E-05 12	0.04 4
1588.61 4	0.37 4	0.316 22 *1*	2.22E-04 19	2.49E-04 17 *1*	0.78 5
1702.95 15	0.040 10	0.040 10		3.1E-05 10	0.098 25
1712.92 4	1.5 3	1.50 10	0.00118 7	0.00118 7	3.69 21
1964.61 10	0.060 20	0.092 18 *1*	8.5E-05 20	7.2E-05 14	0.23 4
1978.25 3	1.42 11	1.41 7	0.00110 6	0.00111 5	3.46 15
2214.06 15	0.40 5	0.36 4	2.3E-04 4	0.00029 3 *1*	0.89 9
2216.42 9	0.25 4	0.22 3	1.3E-04 3	1.75E-04 23 *1*	0.55 7
2438.54 3	6.3 4	6.0 3	0.00459 22	0.00472 19	14.8 6
2552.88 15	0.030 10	0.030 10		2.4E-05 9	0.074 25
2563.21 4	0.070 20	0.070 20		5.5E-05 16	0.17 5
2801.37 9	0.170 20	0.158 17	8.2E-05 20	1.24E-04 14 *2*	0.39 4
2828.172 25	30.5 10	30.5 9	0.0239 11	0.0240 8	74.9 20
2972.2 5	0.090 20	0.090 20		7.1E-05 17	0.22 5
3054.00 3	10.4 5	10.5 4	0.0083 4	0.0082 3	25.8 9
3301.41 3	7.7 4	7.9 3	0.0063 3	0.00619 24	19.3 7
3413.10 3	5.1 3	5.09 21	0.00400 20	0.00400 16	12.5 5
3691.02 3	0.90 8	0.86 5	0.00065 5	0.00067 4	2.11 12
3916.84 3	41.0 13	40.7 11	0.0314 15	0.0320 11	100 3
4141.31 14	0.21 3	0.195 20	1.42E-04 20	1.53E-04 16	0.48 5
4528.55 9	0.46 4	0.44 3	0.00029 5	0.00035 3 *1*	1.09 8
4766.69 4	0.41 4	0.42 3	0.00033 3	0.000326 22	1.02 7
6354.98 3	1.31 9	1.35 7	0.00109 8	0.00106 6	3.31 17
6744.54 3	0.18 3	0.18 3		1.42E-04 25	0.44 7
7329.38 4	0.018 4	0.018 4		1.4E-05 3	0.044 10

ENSDF: $\chi^2/f = 0.266$ skew = - 0.214, f = 35.

Budapest: $\chi^2/f = 0.595$ skew = - 1.780, f = 25.

Gamma-ray intensity balances through the level scheme were used to determine the quality and completeness of the evaluated data. The total gamma-ray cross section feeding the ground state was compared with the corresponding values from Mughabghab et al [6.23-6.25], and the ratio of the total primary gamma-ray cross section to the cross section feeding the ground state indicated the completeness of the dataset. Intensity balances through intermediary levels indicate missing or anomalous intensities, and such problems were corrected whenever possible. An example of an intensity balance analysis with no important discrepancies is shown in Table 6.4 Level schemes are complete for the more abundant isotopes of the light nuclei, but significant inconsistencies in the intensity balance may arise for heavier nuclei and remain unresolved in the continuum.

Table 6.4 Cross-section balance for $^{24}\text{Mg}(n, \gamma)$ adopted data.

E(Level)	$\sigma(\text{in})$	$\sigma(\text{out})$	$\Delta\sigma$
0	0.0536(14)	0.0	0
585.01(3)	0.0406(11)	0.0398(14)	0.0008(18)
974.68(3)	0.0157(4)	0.0158(4)	0.0001(6)
1964.69(10)	0.00022(2)	0.00026(3)	0.00004(4)
2563.35(4)	0.00202(10)	0.00179(7)	0.00023(12)
2801.54(9)	0.00047(4)	0.00061(5)	0.00013(6)
3413.35(3)	0.0411(14)	0.0416(11)	0.0005(18)
4276.33(4)	0.0105(4)	0.0107(3)	0.0002(5)
4358.2(5)	0.00009(2)	0.0	0.00009(2)
5116.37(15)	0.00038(4)	0.00027(3)	0.00011(5)
7330.53(4)	0.0	0.0539(14)	0.0539(14)
$\sigma(\text{Mughabghab [6.23]})$ 0.0536(15) b			
$\sigma(\text{Measured, average})$ 0.0538(14) b			

6.5. Radioactive decay data

Gamma rays emitted by radioactive decay from isomers and activation products were observed simultaneously with the prompt gamma rays and have been included in this evaluation. Decay data were taken from the relevant ENSDF datasets and renormalized using the total cross sections from Mughabghab et al. [6.23-6.25], other literature, or the Budapest experimental data (only used when corrections for bombardment time were negligible). These data must be corrected for decay and saturation as described in Chapter 7.

Several naturally abundant isotopes emit gamma rays that can be used for quantitative analysis. Data are included for ^{40}K (1.265×10^9 y), ^{50}V (1.4×10^{14} y), ^{138}La (1.05×10^{11} y), ^{176}Lu (4.00×10^{10} y), ^{232}Th (1.405×10^{10} y), and ^{235}U (7.038×10^8 y). These gamma-ray intensities are provided in units of disintegrations per second per gram of the element.

REFERENCES

- [6.1] LONE, M.A., LEAVITT, R.A., HARRISON, D.A., Prompt Gamma Rays from Thermal-neutron Capture, *At. Data Nucl. Data Tables* **26**, (1981) 511.
- [6.2] RASMUSSEN, N. C., HUKAI, Y., INOUE, T., ORPHAN, V. J., Thermal Neutron Capture Gamma-Ray Spectra of the Elements, Massachusetts Institute of Technology Report AFCRL-69-0071, 1969.
- [6.3] ORPHAN, V. J., RASMUSSEN, N. C., HARPER, T. L., Line and Continuum Gamma-Ray Yields from Thermal-Neutron Capture in 75 Elements, Gulf General Atomic Report DASA 2570 (GA 10248), 1970.
- [6.4] Evaluated Nuclear Structure Data File, a computer file of evaluated experimental nuclear structure data maintained by the National Nuclear Data Center, Brookhaven National Laboratory, USA.
- [6.5] CHUNMEI, Z., Thermal Neutron Capture Data for A = 1-25, INDC(CPR)-051, 2000.
- [6.6] CHUNMEI, Z., Thermal Neutron Capture Data for A = 26-35, INDC(CPR)-054, 2001.
- [6.7] CHUNMEI, Z., Thermal Neutron Capture Data Update and Revision for Some Nuclides with A > 190, INDC(CPR)-055, 2001.
- [6.8] CHUNMEI, Z., FIRESTONE, R.B., Thermal Neutron Capture Data for A = 36-44, INDC(CPR)-057, 2003.
- [6.9] REEDY, R.C., FRANKLE, S.C., Prompt Gamma Rays from Radiative Capture of Thermal Neutrons by Elements from Hydrogen through Zinc, *At. Data Nucl. Data Tables* **80** (2002) 1.
- [6.10] REEDY, R.C., FRANKLE, S.C., Evaluated Database for Prompt Gamma Rays from Radiative Capture of Thermal Neutrons by Elements from Hydrogen to Zinc, IAEA-NDS-209, 2003.
- [6.11] MOLNÁR, G.L., RÉVAY, Z., BELGYA, T., Wide energy range efficiency calibration method for Ge detectors, *Nucl. Instrum. Meth. Phys. Res.* **A489** (2002) 140-159.
- [6.12] KRUSCHE, B., LIEB, K.P., DANIEL, H., VON EGIDY, T., BARREAU, G., NORNER, H.G., BRISSOT, R., HOFMEYER, C., RASCHER, R., Gamma ray energies and ^{36}Cl level scheme from the reaction $^{35}\text{Cl}(n, \gamma)^{36}\text{Cl}$, *Nucl. Phys.* **A386** (1982) 245-268.
- [6.13] MOLNÁR, G.L., RÉVAY, Z., PAUL, R.L., LINDSTROM, R.M., Prompt-gamma activation analysis using the k_0 approach, *J. Radioanal. Nucl. Chem.* **234** (1998) 21-26.
- [6.14] RÉVAY, Z., MOLNÁR, G.L., BELGYA, T., KASZTOVSZKY, Z., FIRESTONE, R.B., A new gamma-ray spectrum catalog for PGAA, *J. Radioanal. Nucl. Chem.* **244** (2000) 383-389.
- [6.15] RÉVAY, Z., MOLNÁR, G.L., "Characterization of neutron beam and gamma spectrometer for PGAA, pp. 57-68 in Summary Report of 2nd Research Coordination Mtg. on Development of a Database for Prompt Gamma-ray Activation Analysis, INDC(NDS)-424, International Atomic Energy Agency, Vienna, 2001.
- [6.16] FIRESTONE, R.B., RÉVAY, Z., MOLNÁR, G.L., "New capture gamma-ray library and atlas of spectra for all elements", pp. 507-513 in Proc. 11th Int. Symp. Capture Gamma-Ray Spectroscopy and Related Topics, KVASIL, J., CEJNAR, P., KRTIČKA, M., (Eds.), World Scientific, Singapore, 2003.
- [6.17] MOLNÁR, G.L., RÉVAY, Z., BELGYA, T., FIRESTONE, R.B., The new prompt gamma-ray catalogue for PGAA, *Appl. Radiat. Isot.* **53** (2000) 527-533.
- [6.18] RÉVAY, Z., MOLNÁR, G.L., BELGYA, T., KASZTOVSZKY, Z., FIRESTONE, R.B., A new gamma-ray spectrum catalog and library for PGAA, *J. Radioanal. Nucl. Chem.* **248** (2001) 395-399.
- [6.19] RÉVAY, Z., MOLNÁR, Standardisation of the prompt gamma activation analysis method, *Radiochim. Acta* **91** (2003) 361-369.

- [6.20] RÉVAY, Z., MOLNÁR, G.L., BELGYA, T., KASZTOVSZKY, Z., In-beam determination of k_0 factors of short-lived nuclides, *J. Radioanal. Nucl. Chem.* **257** (2003) 561-564.
- [6.21] Nuclear Science Reference File, a bibliographic computer file of nuclear science references continually updated by the National Nuclear Data Center, Brookhaven National Laboratory; recent literature scanned by D. Winchell.
- [6.22] ROSMAN, K.J.R., TAYLOR, P.D.P., "Isotopic Composition of the Elements 1997", *Pure Appl. Chem.* **70** (1998) 217.
- [6.23] MUGHABGHAB, S.F., Thermal Neutron Capture Cross Sections, Resonance Integrals, and g-factors, INDC(NDS)-440, 2003.
- [6.24] MUGHABGHAB, S.F., DIVADEENAM, M., HOLDEN, N., Neutron Cross Sections, Vol. 1, Part A, Z = 1-60, Academic Press, New York, 1981.
- [6.25] MUGHABGHAB, S.F., Neutron Cross Sections, Vol. 1, Part B, Z = 61-100, Academic Press, New York, 1984.

7. ADOPTED DATABASE AND USER TABLES

R.B. Firestone

The Evaluated Gamma-ray Activation File (EGAF) is a database of $\approx 32,000$ adopted prompt gamma rays and ≈ 3000 gamma rays emitted by radioactive decay, and has been created for all stable isotopes of the elements from hydrogen to uranium. This complete EGAF database is available on the accompanying CD-ROM in both tabulated and Evaluated Nuclear Structure Data File (ENSDF) format [7.1]. Selected gamma rays with partial cross sections $>1\%$ of the most intense transitions are presented in the following tables, in which at least one prompt gamma ray and at least one decay gamma ray (when applicable) are listed for each isotope regardless of intensity. Energy-ordered gamma rays are given for each element with isotopic identification, energy and uncertainty in keV, and partial elemental cross section and k_0 and their uncertainties.

7.1. Numerical uncertainty presentation

Uncertainties in the tables are contained within parentheses, and expressed in terms of the last digit or digits of the recommended value without a decimal point. These uncertainties are defined as standard deviations corresponding to the 1σ confidence level, for example:

$$1234.5(12) \equiv 1234.5 \pm 1.2$$

$$1.234(5) \equiv 1.234 \pm 0.005$$

$$1.23(4) \times 10^{-5} \equiv (1.23 \pm 0.04) \times 10^{-5}$$

7.2. Isotopic data

The isotopic data are presented in Table 7.1. The first three columns give the atomic number Z , element symbol El , and mass number A , respectively. The natural abundances (θ) quoted in column 4 are representative isotopic compositions (Atom %) from the 1997 IUPAC values listed by Rosman and Taylor [7.2]. Thermal radiative cross sections (σ_γ) are listed in column 5 and discussed in Chapter 5 [7.3-7.5], while Trkov calculated the Westcott g -factors for 293K as listed in column 6 [7.6]. The number of prompt gamma rays reported for each isotope is given in column 7 (N_γ), and the most intense prompt capture gamma rays for that element is quantified in column 8.

7.3. Radioactive decay data

Gamma rays emitted by the radioactive decay of isomers and activation products are observed simultaneously with the prompt gamma rays and have been included in this evaluation. Decay data were taken from the ENSDF file and renormalized to the total radiative cross sections of Mughabghab [7.3-7.5] or to Budapest experimental data if corrections for the bombardment time were negligible. Radioactive decay data are presented in Table 7.2. The first column gives the mass number A and element symbol El . The decay mode is given in column 2 and the half-life in column 3. Column 4 indicates the %BR branching intensity for the indicated decay mode and column 5 gives the number of decay gamma rays N_γ reported for each parent and decay mode. Column 6 shows the energies E_γ and partial elemental gamma ray cross sections $\sigma_\gamma^z(E_\gamma)$ for the principal decay gammas. The naturally abundant radioisotopes ^{40}K , ^{50}V , ^{138}La , ^{176}Lu , ^{232}Th , and ^{235}U are indicated by (*nat*) next to the element symbol and the principal decay gamma ray activity in disintegrations per second per gram of the element is shown instead of the partial elemental gamma ray cross section $\sigma_\gamma^z(E_\gamma)$.

7.4. k_0 formulation

The k_0 formulation is commonly used in activation analysis because the product of the yield and cross section can usually be measured with greater accuracy than either parameter alone. A value of k_0 for a gamma ray emitted from isotope i is defined relative to the hydrogen standard on a mass scale:

$$\begin{aligned}k_0(E_\gamma) &= k_Z(E_\gamma) / k_H(2223) \\ &= [\sigma_\gamma^Z(E_\gamma) / A_r(Z)] / [\sigma_\gamma^H(2223) / A_r(H)] \\ &= 3.03 \times [\sigma_\gamma^Z(E_\gamma) / A_r(Z)]\end{aligned}$$

where $\sigma_\gamma^Z(E_\gamma)$ is the partial elemental cross section in barns for the production of gamma ray E_γ from element Z , assuming natural abundance, and $A_r(Z)$ is the relative atomic weight of element Z . The partial elemental cross section for neutron capture on hydrogen is $\sigma_\gamma^H(2223) = 0.3326(7)$ and the $A_r(H) = 1.00794$, and $k_0(2223) \equiv 1$ by definition. For example, consider the 841.0-keV gamma ray from $^{32}\text{S}(n, \gamma)$ with $\sigma(841) = 0.347$ b and $A_r(\text{S}) = 32.066$:

$$k_0(841) = 3.03 \times 0.347 / 32.066 = 0.0328$$

7.5. PGAA data tables

Adopted PGAA database of prompt and delayed gamma rays is presented in Table 7.3.

7.5.1. Prompt gamma rays

Only k_0 values that are >1% of the largest value for each element are listed in Table 7.3, while those that are >10% are shown in bold type. Gamma rays with $k_0 < 1\%$ of the largest value are included in the full database on the CD-ROM. Both $\sigma_\gamma^Z(E_\gamma)$ and $k_0(E_\gamma)$ values presented in this evaluation have the same percentage uncertainties because they are measured with respect to the very precise hydrogen value.

The 477.6-keV gamma ray from the $^{10}\text{B}(n, \alpha)$ reaction is uniquely identified in Table 7.3 because this emission undergoes Doppler broadening to a width of ≈ 15 keV.

The IUPAC atomic weight values [7.7] were used in the calculation of k_0 , and the elemental cross section are shown in the header for each element in Table 7.3.

7.5.2. Radioactive decay gamma rays

Gamma rays from radioactive decay are denoted in Table 7.3 by d immediately after the energy and uncertainty. Saturation values for k_0 are listed, but many half-lives are too long for saturation to occur under normal experimental conditions. Percent saturation has been calculated, assuming 1-hour irradiation:

$$\% \text{ Saturation} = 100 \times [1.0 - (1.0 - e^{-\lambda t}) / \lambda t]$$

where $\lambda = \ln(2) / t_{1/2}$ and $t = 3600$ s. They are given in parentheses after the $k_0(E_\gamma)$ decay values in Table 7.3. Only decay gamma rays with $k_0(E_\gamma) > 10\%$ of the largest k_0 values or the most intense gamma ray are listed in Table 7.3.

Gamma rays from several naturally abundant radioisotopes are included in Table 7.3 and indicated as “abundant” in the k_0 column. Instead of k_0 and $\sigma_\gamma^Z(E_\gamma)$, the gamma emission rate

per second per gram of the element is given as calculated by:

$$\begin{aligned}\text{Gamma Emission Rate (s}^{-1}\text{g}^{-1}) &= \lambda N P_{\gamma} \\ &= [\ln(2) / t_{1/2}] \times [N_A / A_r(Z)] \times \theta \times P_{\gamma}\end{aligned}$$

where $t_{1/2}$ is the half-life, $N_A = 6.022 \times 10^{23} \text{ mol}^{-1}$, θ is the isotopic abundance (atom %), and P_{γ} is the absolute gamma-ray intensity per decay.

7.5.3. *Energy-ordered gamma-ray table*

Table 7.4 presents a list of energy-ordered gamma rays with $\sigma_{\gamma}^z(E_{\gamma})$ and $k_0(E_{\gamma})$ values and the most intense gamma rays associated with these transitions. This table was abbreviated to include only those gamma rays with $k_0(E_{\gamma}) > 10\%$ of the largest value for each element (total of ≈ 1300 transitions). Radioactive decay transitions are also included, and have been appended with *d* immediately after the gamma-ray energy and uncertainty.

REFERENCES

- [7.1] TULI, J.K., "The Evaluated Nuclear Structure Data File: A Manual for the Preparation of Datasets", BNL-NCS-51655-01/02-Rev, February 2001.
- [7.2] ROSMAN, K.J.R., TAYLOR, P.D.P., "Isotopic Composition of the Elements 1997", Pure Appl. Chem. **70** (1998) 217.
- [7.3] MUGHABGHAB, S.F., Thermal Neutron Capture Cross Sections, Resonance Integrals, and g-factors, INDC(NDS)-440 (2003).
- [7.4] MUGHABGHAB, S.F., DIVADEENAM, M., HOLDEN, N., Neutron Cross Sections, Vol. 1, Part A, Z = 1-60, Academic Press, New York, 1981.
- [7.5] MUGHABGHAB, S.F., Neutron Cross Sections, Vol. 1, Part B, Z = 61-100, Academic Press, New York, 1984.
- [7.6] TRKOV, A., IAEA Nuclear Data Section, private communication, 2003.
- [7.7] COPLEN, T.B., Atomic Weights of Elements 1999, J. Phys. Chem. Res. **30** (2001) 701-712.

Table 7.1 Isotopic data. Abundances are from Rosman and Taylor [7.2], σ_γ from Mughabab et al [7.3-5], and g-factors are from Trkov [7.6]. The number of prompt gamma rays (N_γ) reported for each isotope and the most intense gamma rays for each element are shown.

Z	El	A	Abundance(%)	σ_γ (total)	g(293K)	N_γ	E_γ , $\sigma_\gamma^z(E_\gamma)$ for most intense capture gammas for each element
1	H	1	99.9885(70)	0.3326(7)	0.999	1	2223.24835(0.3326)
	H	2	0.0115(70)	0.000519(7)	1.000	1	
2	He	3	0.000137(3)	0.000031(9)	1.000	1	
	He	4	99.999863(3)	0	1.000	0	
3	Li	6	7.59(4)	0.039(4)	1.000	3	
	Li	7	92.41(4)	0.045(3)	1.000	3	2032.30(0.0381), 980.53(0.00415), 1051.90(0.00414)
4	Be	9	100	0.0088(4)	1.000	13	6809.61(0.0058), 3367.448(0.00285), 853.630(0.00208)
5	B	10	19.9(7)	0.5(1)	1.000	10	477.595(716)
	B	11	80.1(7)	0.005(3)	1.000	0	
6	C	12	98.93(8)	0.00353(5)	1.000	6	4945.301(0.00261), 1261.765(0.00124), 3683.920(0.00122)
	C	13	1.07(8)	0.00137(4)	0.998	7	
7	N	14	99.632(7)	0.0798(14)	1.000	60	5269.159(0.0236), 5297.821(0.01680), 5533.395(0.0155)
	N	15	0.368(7)	0.000024(8)	1.003	12	
8	O	16	99.757(16)	0.000190(19)	1.000	4	
	O	17	0.038(1)	0.00054(7)	0.999	20	
	O	18	0.205(14)	0.00016(1)	1.000	13	
9	F	19	100	0.0096(5)	1.000	168	1633.53(0.0096)d, 583.561(0.00356), 656.006(0.00197)
10	Ne	20	90.48(3)	0.037(4)	1.000	27	2035.67(0.0245), 350.72(0.0198), 4374.13(0.01910)
	Ne	21	0.27(1)	0.67(11)	1.000	11	
	Ne	22	9.25(3)	0.045(6)	1.000	15	1979.89(0.00306), 1017.00(0.0030)
11	Na	23	100	0.530(5)	1.000	240	1368.66(0.530)d, 2754.13(0.530)d, 472.202(0.478)d
12	Mg	24	78.99(4)	0.0536(15)	1.001	35	3916.84(0.0320), 585.00(0.0314), 2828.172(0.0240)
	Mg	25	10.00(1)	0.200(5)	1.001	206	1808.668(0.0180), 1129.575(0.00891), 3831.480(0.00418)
	Mg	26	11.01(3)	0.0386(6)	1.001	44	
13	Al	27	100	0.231(3)	1.000	216	1778.92(0.232)d, 30.6380(0.0798), 7724.027(0.0493)
14	Si	28	92.2297(7)	0.177(5)	1.001	46	3538.966(0.1190), 4933.889(0.1120), 2092.902(0.0331)
	Si	29	4.6832(5)	0.119(3)	1.003	99	
	Si	30	3.0872(5)	0.107(2)	1.007	39	
15	P	31	100	0.172(6)	1.001	158	512.646(0.079), 78.083(0.059), 636.663(0.0311)
16	S	32	94.93(31)	0.548(10)	1.000	101	840.993(0.347), 5420.574(0.308), 2379.661(0.208)

Z	El	A	Abundance(%)	$\sigma_{\gamma}(\text{total})$	g(293K)	N_{γ}	E_{γ}	$\sigma_{\gamma}^z(E_{\gamma})$	for most intense capture gammas for each element
	S	33	0.76(2)	0.454(25)	1.001	249			
	S	34	4.29(28)	0.235(5)	1.001	55			
	S	36	0.02(1)	0.23(2)	1.014	22			
17	Cl	35	75.78(4)	43.5(4)	1.000	384	1164.8650(8.91), 517.0730(7.58), 6110.842(6.59)		
	Cl	37	24.22(4)	0.430(6)	1.000	71			
18	Ar	36	0.3365(30)	5.2(5)	1.016	10			
	Ar	38	0.0632(5)	0.8(2)	1.040	0			
	Ar	40	99.6003(30)	0.66(1)	1.002	40	167.30(0.53), 4745.3(0.36), 1186.8(0.34)		
19	K	39	93.2581(44)	2.1(2)	1.001	308	29.8300(1.380), 770.3050(0.903), 1158.887(0.1600)		
	K	40	0.0117(1)	30(4)	1.000	490			
	K	41	6.7302(44)	1.45(3)	1.001	638			
20	Ca	40	96.94(16)	0.41(2)	1.001	49	1942.67(0.352), 6419.59(0.176), 4418.52(0.0708)		
	Ca	42	0.647(23)	0.68(7)	1.001	44			
	Ca	43	0.135(10)	6.2(6)	1.001	129			
	Ca	44	2.09(11)	0.88(5)	1.001	41			
	Ca	46	0.004(3)	0.72(3)	1.000	10			
	Ca	48	0.187(21)	1.09(14)	1.001	15			
21	Sc	45	100	27.2(2)	1.002	440	227.773(7.13), 147.011(6.08), 142.528(4.88)d		
22	Ti	46	8.25(3)	0.59(18)	1.001	23			
	Ti	47	7.44(2)	1.52(11)	1.001	175			
	Ti	48	73.72(3)	7.88(25)	1.002	92	1381.745(5.18), 6760.084(2.97), 6418.426(1.96)		
	Ti	49	5.41(2)	1.79(12)	1.001	88			
	Ti	50	5.18(2)	0.179(3)	1.001	19			
23	V	50	0.250(4)	21(4)	0.999	328			
	V	51	99.750(4)	4.92(4)	1.001	309	1434.10(4.81)d, 125.082(1.61), 6517.282(0.78)		
24	Cr	50	4.345(13)	15.9(2)	1.000	64	749.09(0.569), 8510.77(0.233), 8482.80(0.169)		
	Cr	52	83.789(18)	0.76(6)	1.000	16	7938.46(0.424)		
	Cr	53	9.501(17)	18.2(15)	1.000	90	834.849(1.38), 8884.36(0.78), 9719.06(0.260)		
	Cr	54	2.365(7)	0.36(4)	1.000	38			
25	Mn	55	100	13.36(5)	1.000	126	846.754(13.10)d, 1810.72(3.62)d, 26.560(3.42)		
26	Fe	54	5.845(35)	2.25(18)	1.001	33	9297.68(0.0747)		
	Fe	56	91.754(36)	2.59(14)	1.000	193	7631.136(0.653), 7645.5450(0.549), 352.347(0.273)		
	Fe	57	2.119(10)	2.5(3)	1.001	35			

Z	El	A	Abundance(%)	$\sigma_{\gamma}(\text{total})$	g(293K)	N_{γ}	E_{γ}	$\sigma_{\gamma}^z(E_{\gamma})$	for most intense capture gammas for each element
76	Fe	58	0.282(4)	1.30(3)	1.002	67			
27	Co	59	100	37.18(6)	1.000	340	229.879(7.18), 277.161(6.77), 555.972(5.76)		
28	Ni	58	68.0769(89)	4.5(2)	1.000	236	8998.414(1.49), 464.978(0.843), 8533.509(0.721)		
	Ni	60	26.2231(77)	2.9(2)	1.000	137	7819.517(0.336), 282.917(0.211), 7536.637(0.190)		
	Ni	61	1.1399(6)	2.5(8)	1.000	64			
	Ni	62	3.6345(17)	14.5(3)	1.000	53	6837.50(0.458)		
	Ni	64	0.9256(9)	1.63(7)	1.000	35			
29	Cu	63	69.17(3)	4.52(2)	1.001	306	278.250(0.893), 7915.62(0.869), 159.281(0.648)		
	Cu	65	30.83(3)	2.17(3)	1.002	350	185.96(0.244), 465.14(0.1350), 385.77(0.1310)		
30	Zn	64	48.63(60)	1.1(1)	1.001	78	115.225(0.167), 7863.55(0.1410), 855.69(0.066)		
	Zn	66	27.90(27)	0.62(6)	1.000	17	6958.8(0.043)		
	Zn	67	4.10(13)	9.5(14)	1.000	175	1077.335(0.356), 1883.12(0.0718), 1340.14(0.0457)		
	Zn	68	18.75(51)	1.07(10)	1.000	33	1007.809(0.056), 5474.02(0.042), 834.77(0.037)		
	Zn	70	0.62(3)	0.091(5)	1.000	79			
31	Ga	69	60.108(9)	1.68(7)	1.000	68	508.19(0.349), 690.943(0.305), 187.84(0.1080)		
	Ga	71	39.892(9)	4.73(15)	1.001	245	834.08(1.65)d, 2201.91(0.52)d, 629.96(0.490)d		
32	Ge	70	20.84(87)	3.45(16)	1.000	84	175.05(0.164), 499.87(0.162)		
	Ge	72	27.54(34)	0.95(11)	1.000	48			
	Ge	73	7.73(5)	14.4(4)	1.000	603	595.851(1.100), 867.899(0.553), 608.353(0.250)		
	Ge	74	36.28(73)	0.53(5)	1.000	47			
	Ge	76	7.61(38)	0.14(2)	1.000	196			
33	As	75	100	4.23(8)	1.000	348	559.10(2.00)d, 165.0490(0.996), 86.7880(0.579)		
34	Se	74	0.89(4)	51.8(12)	1.001	142	286.5710(0.280)		
	Se	76	9.37(29)	85(7)	1.000	456	238.9980(2.06), 520.6370(1.260), 161.9220(0.855)d		
	Se	77	7.63(16)	42(4)	1.000	215	613.724(2.14), 694.914(0.443), 1308.632(0.317)		
	Se	78	23.77(28)	0.430(22)	1.000	37			
	Se	80	49.61(41)	0.61(5)	1.000	71			
	Se	82	8.73(22)	0.044(3)	1.000	0			
35	Br	79	50.69(7)	10.32(13)	1.000	257	245.203(0.80), 271.374(0.462), 314.982(0.460)		
	Br	81	49.31(7)	2.36(5)	1.000	181	776.517(0.990)d, 554.3480(0.838)d, 619.106(0.515)d		
36	Kr	78	0.35(1)	4.7(7)	1.000	1			
	Kr	80	2.28(6)	11.5(5)	1.000	1			
	Kr	82	11.58(14)	19(4)	1.000	2			

Z	El	A	Abundance(%)	$\sigma_{\gamma}(\text{total})$	g(293K)	N_{γ}	E_{γ}	$\sigma_{\gamma}^z(E_{\gamma})$	for most intense capture gammas for each element
	Kr	83	11.49(6)	202(10)	0.995	75	881.74(20.8), 1213.42(8.28), 1463.86(7.10)		
	Kr	84	57.00(4)	0.111(15)	1.000	7			
	Kr	86	17.30(22)	0.003(2)	1.000	38			
37	Rb	85	72.17(2)	0.48(9)	1.000	90	556.82(0.0913), 487.89(0.0494), 555.61(0.0407)d		
	Rb	87	27.83(2)	0.12(3)	1.000	86	196.34(0.00964)		
38	Sr	84	0.56(1)	0.62(6)	1.000	5			
	Sr	86	9.86(1)	1.04(7)	1.000	375			
	Sr	87	7.00(1)	17(3)	1.006	210	1836.067(1.030), 898.055(0.702), 850.657(0.275)		
	Sr	88	82.58(1)	0.0058(4)	1.000	57			
39	Y	89	100	1.28(2)	1.005	397	6080.171(0.76), 776.613(0.659), 202.53(0.289)		
40	Zr	90	51.45(40)	0.011(5)	1.000	15	1465.7(0.037), 1205.6(0.025), 2042.2(0.019)		
	Zr	91	11.22(5)	1.24(25)	1.000	81	934.4640(0.0737), 1405.159(0.0178), 560.958(0.0169)		
	Zr	92	17.15(8)	0.22(6)	1.000	18			
	Zr	94	17.38(28)	0.0499(24)	1.000	14			
	Zr	96	2.80(9)	0.020(1)	1.000	34	1102.67(0.0139)		
41	Nb	93	100	1.15(5)	1.002	535	99.4070(0.211), 255.9290(0.190), 253.115(0.1420)		
42	Mo	92	14.84(35)	0.019	1.000	5			
	Mo	94	9.25(12)	0.015	1.001	13			
	Mo	95	15.92(13)	13.4(3)	0.998	139	778.221(2.02), 849.85(0.43), 847.603(0.324)		
	Mo	96	16.68(2)	0.5(2)	1.001	36			
	Mo	97	9.55(8)	2.5(2)	0.998	110			
	Mo	98	24.13(31)	0.137(5)	1.000	56			
	Mo	100	9.63(23)	0.199(3)	1.000	332			
44	Ru	96	5.54(14)	0.22(2)	1.001	2			
	Ru	98	1.87(3)	<8.0	1.002	1			
	Ru	99	12.76(14)	7.1(10)	1.002	134	539.538(1.53), 686.907(0.52)		
	Ru	100	12.60(7)	5.0(6)	1.000	32			
	Ru	101	17.06(2)	3.4(9)	1.001	60	475.0950(0.98), 631.22(0.30), 627.970(0.176)		
	Ru	102	31.55(14)	1.21(7)	1.000	173	1959.30(0.210)		
	Ru	104	18.62(27)	0.47(2)	1.000	183			
45	Rh	103	100	145(2)	1.023	264	180.87(22.6), 97.14(19.5), 51.50(16.0)		
46	Pd	102	1.02(1)	3.4(3)	0.997	4			
	Pd	104	11.14(8)	0.6(3)	1.000	11			

Z	El	A	Abundance(%)	$\sigma_{\gamma}(\text{total})$	g(293K)	N_{γ}	E_{γ}	$\sigma_{\gamma}^z(E_{\gamma})$	for most intense capture gammas for each element
	Pd	105	22.33(8)	21.0(15)	0.995	114	511.843(4.00), 717.356(0.777), 616.192(0.629)		
	Pd	106	27.33(3)	0.31(3)	0.999	7			
	Pd	108	26.46(9)	7.6(4)	1.000	140			
	Pd	110	11.72(9)	0.23(3)	1.000	87			
47	Ag	107	51.839(8)	37.6(12)	0.998	172	78.91(3.90), 206.46(3.58), 192.90(2.20)		
	Ag	109	48.161(8)	91(1)	1.005	130	198.72(7.75), 235.62(4.62), 117.45(3.85)		
48	Cd	106	1.25(6)	~1.0	1.000	0			
	Cd	108	0.89(3)	0.72(13)	1.001	0			
	Cd	110	12.49(18)	11(1)	1.000	191	245.3(274)		
	Cd	111	12.80(12)	24(3)	0.995	5			
	Cd	112	24.13(21)	2.2(5)	1.000	0			
	Cd	113	12.22(12)	20600(400)	1.337	135	558.32(1860), 651.19(358)		
	Cd	114	28.73(42)	0.34(2)	1.000	0			
	Cd	116	7.49(18)	0.075(20)	1.000	0			
49	In	113	4.29(5)	15.1(13)	1.012	232			
	In	115	95.71(5)	283(8)	1.019	199	1293.54(131)d, 1097.30(87.3)d, 416.86(43.0)d		
50	Sn	112	0.97(1)	0.86(9)	1.000	0			
	Sn	114	0.66(1)	0.12(3)	1.001	0			
	Sn	115	0.34(1)	30(7)	1.000	395	1293.591(0.1340), 972.619(0.0158), 2112.302(0.0152)		
	Sn	116	14.54(9)	0.14(3)	1.000	9	158.65(0.0145)		
	Sn	117	7.68(7)	1.32(18)	1.000	19	1229.64(0.0673)		
	Sn	118	24.22(9)	0.23(5)	1.000	9			
	Sn	119	8.59(4)	2.2(5)	1.000	9	1171.28(0.0879)		
	Sn	120	32.58(9)	0.14(3)	1.000	10			
	Sn	122	4.63(3)	0.139(15)	1.000	9			
	Sn	124	5.79(5)	0.134(5)	1.000	25			
51	Sb	121	57.21(5)	5.9(2)	1.003	151	564.24(2.700)d, 61.4130(0.75), 78.0910(0.48)		
	Sb	123	42.79(5)	4.1(1)	1.001	175	87.6010(0.212), 40.8040(0.10), 155.1780(0.081)		
52	Te	120	0.09(1)	2.3(3)	1.000	0			
	Te	122	2.55(12)	3.9(5)	1.000	113			
	Te	123	0.89(3)	418(30)	1.011	162	602.729(2.46), 722.772(0.52), 645.819(0.263)		
	Te	124	4.74(14)	6.8(13)	1.000	280			
	Te	125	7.07(15)	1.55(16)	1.000	8			

Z	El	A	Abundance(%)	$\sigma_{\gamma}(\text{total})$	g(293K)	N_{γ}	E_{γ}	$\sigma_{\gamma}^z(E_{\gamma})$	for most intense capture gammas for each element
	Te	126	18.84(25)	1.0(15)	1.000	2			
	Te	128	31.74(8)	0.215(8)	1.000	23			
	Te	130	34.08(62)	0.29(6)	1.000	258			
53	I	127	100	6.2(2)	0.999	348	133.6110(1.42), 442.901(0.595)d, 27.3620(0.43)		
54	Xe	124	0.09(1)	165(11)	1.004	4			
	Xe	126	0.09(1)	3.8(8)	1.000	0			
	Xe	128	1.92(3)	5.2(13)	0.998	7			
	Xe	129	26.44(24)	21(7)	1.001	59	536.17(1.71)		
	Xe	130	4.08(2)	4.8(12)	0.998	13			
	Xe	131	21.18(3)	85(10)	1.002	72	667.79(6.7), 772.72(1.78), 630.29(1.41)		
	Xe	132	26.89(6)	0.41(5)	1.000	0			
	Xe	134	10.44(10)	0.265(20)	0.999	0			
	Xe	136	8.87(16)	0.26(2)	1.000	113			
55	Cs	133	100	30.3(11)	1.002	384	176.4040(2.47), 205.615(1.560), 510.795(1.54)		
56	Ba	130	0.106(1)	8.7(9)	1.000	2			
	Ba	132	0.101(1)	7.0(8)	0.979	2			
	Ba	134	2.417(18)	1.5(3)	1.000	120			
	Ba	135	6.592(12)	5.8(9)	1.000	87	818.514(0.212), 1261.52(0.095)		
	Ba	136	7.854(24)	0.68(17)	1.000	96	283.58(0.0404)		
	Ba	137	11.232(24)	3.6(2)	1.000	210	1435.77(0.308), 1444.91(0.0801), 462.78(0.0660)		
	Ba	138	71.698(42)	0.40(4)	1.000	48	627.29(0.294), 4095.84(0.155), 454.73(0.0853)		
57	La	138	0.090(1)	57(6)	1.003	6			
	La	139	99.910(1)	9.04(4)	0.999	308	1596.21(5.84)d, 487.021(2.79)d, 815.772(1.430)d		
58	Ce	136	0.185(2)	6.5(10)	0.999	109			
	Ce	138	0.251(2)	1.02(24)	0.991	1			
	Ce	140	88.450(51)	0.58(2)	0.999	29	661.99(0.241), 4766.10(0.113), 475.04(0.082)		
	Ce	142	11.114(51)	0.97(2)	0.998	48	1107.66(0.040), 737.43(0.026), 4336.46(0.0251)		
59	Pr	141	100	11.5(3)	0.999	213	176.8630(1.06), 140.9050(0.479), 1575.6(0.426)d		
60	Nd	142	27.2(5)	18.7(7)	0.998	208	742.106(3.8)		
	Nd	143	12.2(2)	325(10)	0.996	119	696.499(33.3), 618.062(13.4), 814.12(4.98)		
	Nd	144	23.8(3)	3.6(3)	1.000	16			
	Nd	145	8.3(1)	42(2)	1.000	123			
	Nd	146	17.2(3)	1.41(5)	0.999	73			

Z	El	A	Abundance(%)	$\sigma_{\gamma}(\text{total})$	g(293K)	N_{γ}	E_{γ}	$\sigma_{\gamma}^z(E_{\gamma})$	for most intense capture gammas for each element
	Nd	148	5.7(1)	2.58(14)	1.000	298			
	Nd	150	5.6(2)	1.03(8)	0.999	581			
62	Sm	144	3.07(7)	1.64(10)	0.999	0			
	Sm	147	14.99(18)	57(3)	1.001	22			
	Sm	148	11.24(10)	2.4(6)	1.000	0			
	Sm	149	13.82(7)	40100(600)	1.718	160	333.97(4790), 439.40(28601), 737.44(597)		
	Sm	150	7.38(1)	100(4)	0.998	301			
	Sm	152	26.75(16)	206(6)	1.003	160			
	Sm	154	22.75(29)	8.3(5)	1.000	136			
63	Eu	151	47.81(3)	9200(300)	0.900	148	89.847(1430), 77.23(187), 48.31(181)		
	Eu	153	52.19(3)	312(7)	0.966	64			
64	Gd	152	0.20(1)	735(20)	0.998	503			
	Gd	154	2.18(3)	85(12)	1.000	329			
	Gd	155	14.80(12)	60900(500)	0.843	324	199.2130(2020), 88.9670(1380)		
	Gd	156	20.47(9)	1.8(7)	1.001	0			
	Gd	157	15.65(2)	254000(800)	0.852	390	181.931(72003), 79.5100(40101), 944.174(3090)		
	Gd	158	24.84(7)	2.2(2)	1.000	20			
	Gd	160	21.86(19)	1.4(3)	1.000	98			
65	Tb	159	100	23.3(4)	1.000	224	75.0500(1.78), 63.6860(1.46), 64.1100(1.2)		
66	Dy	156	0.06(1)	33(3)	1.009	25			
	Dy	158	0.10(1)	43(6)	0.989	0			
	Dy	160	2.34(8)	55(3)	1.009	100			
	Dy	161	18.91(24)	600(25)	0.991	78	185.19(31.6), 882.27(14.8), 80.64(13.3)		
	Dy	162	25.51(26)	194(10)	1.005	328			
	Dy	163	24.90(16)	134(7)	1.003	45			
	Dy	164	28.18(37)	2650(70)	0.988	271	184.257(118), 538.609(55.9), 496.931(36.3)		
67	Ho	165	100	64.7(12)	1.002	550	136.6650(14.5), 116.8360(8.1), 80.574(3.87)d		
68	Er	162	0.14(1)	19(2)	1.001	1			
	Er	164	1.61(3)	13(2)	1.000	0			
	Er	166	33.61(35)	16.9(16)	1.000	87			
	Er	167	22.93(17)	649(8)	1.069	805	184.2850(56), 815.9890(42.5), 198.2440(29.9)		
	Er	168	26.78(26)	2.74(8)	1.000	102			
	Er	170	14.93(27)	8.9(3)	1.000	97			

Z	El	A	Abundance(%)	$\sigma_{\gamma}(\text{total})$	g(293K)	N_{γ}	E_{γ}	$\sigma_{\gamma}^z(E_{\gamma})$	for most intense capture gammas for each element
69	Tm	169	100	105(2)	1.005	303	204.4480(8.72), 149.7180(7.11), 144.4800(5.96)		
70	Yb	168	0.13(1)	2300(170)	1.057	233	191.2140(0.22)		
	Yb	170	3.04(15)	9.9(18)	1.001	24			
	Yb	171	14.28(57)	58(4)	0.999	266	78.7430(0.67), 181.529(0.53), 1076.246(0.52)		
	Yb	172	21.83(67)	1.3(8)	1.000	25			
	Yb	173	16.13(27)	15.5(15)	1.001	47	175.30(0.58), 102.60(0.44), 76.9960(0.40)		
	Yb	174	31.83(92)	63.2(15)	0.999	176	514.868(9.0)d, 639.261(1.43), 396.329(1.42)d		
	Yb	176	12.76(41)	2.85(5)	1.000	129			
71	Lu	175	97.41(2)	23.1(14)	0.976	304	71.5170(3.96), 225.4030(1.73), 310.1870(1.49)		
	Lu	176	2.59(2)	2090(70)	1.752	184	150.392(13.8), 457.944(8.3), 138.607(6.79)		
72	Hf	174	0.16(1)	549(7)	0.986	23			
	Hf	176	5.26(7)	24(3)	1.002	5			
	Hf	177	18.60(9)	373(10)	1.020	308	213.439(29.3), 93.182(13.3), 325.559(6.69)		
	Hf	178	27.28(7)	137(7)	1.003	347	214.3410(17.7)d, 214.3410(7.2), 303.9880(4.27)		
	Hf	179	13.629(6)	41(3)	0.997	339			
	Hf	180	35.08(16)	13.04(7)	0.997	105			
73	Ta	180	0.012(2)	563(60)	1.358	0			
	Ta	181	99.988(2)	20.5(5)	1.004	262	270.4030(2.60), 173.2050(1.210), 402.623(1.180)		
74	W	180	0.12(1)	<150	0.997	3			
	W	182	26.50(16)	19.9(2)	1.003	131	6190.78(0.45), 46.4840(0.192), 5164.43(0.19)		
	W	183	14.31(4)	10.3(2)	0.999	211	111.216(0.195), 792.059(0.119), 903.274(0.115)		
	W	184	30.64(2)	1.7(1)	0.999	75	4573.7(0.104)		
	W	186	28.42(19)	38.5(5)	1.001	225	685.73(3.24)d, 479.550(2.59)d, 72.002(1.32)d		
75	Re	185	37.40(2)	112(2)	1.004	188	59.0100(5.5), 137.157(5.29)d, 214.647(2.53)		
	Re	187	62.60(2)	79.2(10)	0.982	218	63.5820(8.0), 155.041(7.16)d, 207.853(4.44)		
76	Os	184	0.02(1)	3000(150)	1.000	72			
	Os	186	1.59(3)	80(13)	0.998	38			
	Os	187	1.96(2)	245(40)	0.983	174	155.10(1.19), 633.14(0.585), 478.04(0.523)		
	Os	188	13.24(8)	4.7(5)	1.002	163	272.82(0.242)		
	Os	189	16.15(5)	25(4)	1.004	147	186.7180(2.08), 557.978(0.84), 569.344(0.694)		
	Os	190	26.26(2)	13.1(9)	0.997	76	5146.63(0.409), 527.60(0.300)		
	Os	192	40.78(19)	3.12(16)	1.000	95			
77	Ir	191	37.3(2)	954(10)	0.996	286	351.689(10.9), 84.2740(7.7), 136.1250(6.5)		

Z	El	A	Abundance(%)	$\sigma_{\gamma}(\text{total})$	g(293K)	N_{γ}	E_{γ}	$\sigma_{\gamma}^z(E_{\gamma})$	for most intense capture gammas for each element
	Ir	193	62.7(2)	111(5)	1.017	303	328.448(9.1)d, 371.5020(2.11), 278.5040(1.8)		
78	Pt	190	0.014(1)	142(4)	0.998	0			
	Pt	192	0.782(7)	10.0(25)	1.001	0			
	Pt	194	32.967(99)	0.58(19)	1.000	64			
	Pt	195	33.832(10)	28.5(12)	1.000	235	355.6840(6.17), 332.985(2.580)		
	Pt	196	25.242(41)	0.45(4)	1.000	36			
	Pt	198	7.163(55)	3.66(19)	1.000	44			
79	Au	197	100	98.65(9)	1.005	737	411.8020(94.29)d, 214.9710(9.0), 247.5730(5.56)		
80	Hg	196	0.15(1)	3190(180)	0.988	10			
	Hg	198	9.97(20)	2.0(3)	1.001	3			
	Hg	199	16.87(22)	2150(50)	0.989	425	367.947(251), 5967.02(62.5), 1693.296(56.2)		
	Hg	200	23.10(19)	<60	1.000	0			
	Hg	201	13.18(9)	5.7(12)	1.000	97			
	Hg	202	29.86(26)	4.42(7)	1.000	0			
	Hg	204	6.87(15)	0.43(10)	1.000	13			
81	Tl	203	29.524(14)	11.4(2)	1.000	115	139.94(0.400), 347.96(0.361), 318.88(0.325)		
	Tl	205	70.476(14)	0.104(17)	1.000	13			
82	Pb	204	1.4(1)	0.66(7)	1.001	35			
	Pb	206	24.1(1)	0.0266(12)	1.001	6			
	Pb	207	22.1(1)	0.63(3)	1.001	23	7367.78(0.137)		
	Pb	208	52.4(1)	0.00023(3)	1.003	0			
83	Bi	209	100	0.0338(7)	0.999	230	4171.05(0.0131), 4054.57(0.0105), 319.78(0.0088)		
90	Th	232	100	7.35(3)	0.995	196	583.27(0.279), 566.63(0.19), 472.30(0.165)		
92	U	234	0.0055(5)	99.8(13)	0.990	49			
	U	235	0.7200(51)	98.3(8)	0.985	8	297.00(0.220), 1279.01(0.200), 943.14(0.082)		
	U	238	99.274(11)	2.680(19)	1.002	267	74.6640(1.30000)d, 106.1230(0.723)d, 277.5990(0.382)d		

Table 7.2 Summary of Data for Radioactive Isotopes Produced by Thermal Neutron Activation.

Isotope	Mode	Half-life	%BR	N_γ	E_γ , $\sigma_\gamma^z(E_\gamma)$ for principal decay gammas
¹⁶ N	β-	7.13(2) s	100	12	6128.63(5.90x10 ⁻⁸)
¹⁹ O	β-	26.88(5) s	100	13	197.142(3.15x10 ⁻⁷), 1356.843(1.66x10 ⁻⁷)
²⁰ F	β-	11.163(8) s	100	3	1633.53(0.0096)
²³ Ne	β-	37.24(12) s	100	5	440.0(0.00140)
²⁴ Na	β-	14.9590(12) h	100	6	2754.13(0.530), 1368.66(0.530)
²⁴ Na	IT	20.20(7) ms	99.95(1)	1	472.202(0.478)
²⁷ Mg	β-	9.462(11) m	100	3	843.71(0.00298), 1014.30(0.00117)
²⁸ Al	β-	2.2414(1) m	100	1	1778.92(0.232)
³¹ Si	β-	157.3(3) m	100	1	1266.15(2.5x10 ⁻⁶)
³⁷ S	β-	5.05(2) m	100	7	3103.4(2.8x10 ⁻⁵)
³⁸ Cl	β-	37.24(5) m	100	2	2166.90(0.0568), 1642.5(0.0427)
³⁸ Cl	IT	715(3) ms	100	1	671.355(0.0122)
⁴⁰ K(nat)	EC	1.265(13) x 10 ⁹ y	10.86(13)	1	1460.822(3.24 cps/g)
⁴² K	β-	12.360(12) h	100	8	1524.6(0.0200)
⁴⁹ Ca	β-	8.718(6) m	100	12	3084.40(0.00190)
⁴⁶ Sc	IT	18.75(4) s	100	1	142.528(4.88)
⁵¹ Ti	β-	5.76(1) m	100	3	320.076(0.00860)
⁵⁰ V(nat)	β-	1.4(4) x 10 ¹⁷ y	17(11)	1	783.29(8x10 ⁻⁷ cps/g)
⁵⁰ V(nat)	EC	1.4(4) x 10 ¹⁷ y	83(11)	1	1553.77(3.8x10 ⁻⁶ cps/g)
⁵² V	β-	3.75(1) m	100	13	1434.10(4.81)
⁵⁵ Cr	β-	3.497(3) m	100	7	1528.00(3.80x10 ⁻⁶)
⁵⁶ Mn	β-	2.5789(1) h	100	10	846.754(13.1), 1810.72(3.62), 2113.05(1.91)
⁶⁰ Co	IT	10.467(6) m	99.76(3)	1	58.603(0.411)
⁶⁰ Co	β-	10.467(6) m	0.24(3)	3	1332.89(0.068)
⁶⁵ Ni	β-	2.51719(3) h	100	10	1481.84(0.00330), 1115.53(0.00219), 366.27(0.000680)
⁶⁴ Cu	EC	12.700(2) h	61.0(3)	1	1345.77(0.0155)
⁶⁶ Cu	β-	5.120(14) m	100	3	1038.97(0.0598)
⁶⁹ Zn	β-	13.76(2) h	0.033(3)	1	573.90(4.2x10 ⁻⁶)
⁶⁹ Zn	β-	56.4(9) m	100	2	318.40(2.6x10 ⁻⁶), 871.70(5.5x10 ⁻⁷)
⁶⁹ Zn	IT	13.76(2) h	99.967(3)	1	438.634(0.0128)
⁷¹ Zn	β-	2.45(10) m	100	23	511.60(1.60x10 ⁻⁴), 910.30(4.0x10 ⁻⁵), 390.0(1.97x10 ⁻⁵)
⁷¹ Zn	β-	3.96(5) h	100	56	487.34(3.34x10 ⁻⁵), 620.19(3.04x10 ⁻⁵), 511.55(1.52x10 ⁻⁵)
⁷⁰ Ga	β-	21.14(3) m	99.59(6)	2	1039.20(0.0070), 176.170(0.0030)
⁷² Ga	β-	14.10(1) h	100	82	834.08(1.65), 2201.91(0.52), 629.96(0.490)
⁷² Ga	IT	39.68(13) ms	100	2	103.25(0.0526), 16.43(0.0125)
⁷¹ Ge	IT	20.40(17) ms	100	2	175.05(0.078)
⁷³ Ge	IT	0.499(11) s	100	2	53.440(0.0134)
⁷⁵ Ge	β-	82.78(4) m	100	10	264.60(0.0180), 198.60(0.00190)
⁷⁵ Ge	IT	47.7(5) s	99.970(6)	1	139.68(0.0232)
⁷⁷ Ge	β-	11.30(1) h	100	169	264.44(0.00640), 211.03(0.00367), 215.50(0.00341)
⁷⁷ Ge	IT	52.9(6) s	19(2)	1	159.61(0.00100)
⁷⁷ Ge	β-	52.9(6) s	81(2)	17	215.53(0.0025)
⁷⁶ As	β-	26.24(9) h	100	50	559.10(2.00), 657.05(0.279)
⁷⁷ Se	IT	17.36(5) s	100	1	161.9220(0.855)
⁷⁹ Se	IT	3.92(1) m	100	1	95.73(0.0031)
⁸¹ Se	β-	18.45(12) m	100	10	275.93(0.00160), 290.04(0.00135), 828.27(0.00069)
⁸¹ Se	IT	57.28(2) m	99.949(13)	1	102.89(0.0065)
⁸⁰ Br	β-	17.68(2) m	91.7(2)	4	616.3(0.39)
⁸⁰ Br	EC	17.68(2) m	8.3(2)	2	665.80(0.0628)
⁸⁰ Br	IT	4.4205(8) h	100	2	37.0520(0.428)
⁸² Br	β-	35.30(2) h	100	31	776.517(0.990), 554.3480(0.838), 619.106(0.515)

Isotope	Mode	Half-life	%BR	N_{γ}	E_{γ} , $\sigma_{\gamma}^z(E_{\gamma})$ for principal decay gammas
⁸² Br	IT	6.13(5) m	97.6(3)	1	45.949(0.00285)
⁸² Br	β^-	6.13(5) m	2.4(3)	16	776.50(0.00250), 1474.83(0.00090), 698.21(0.00053)
⁷⁹ Kr	IT	50(3) s	100	1	130.010(1.60x10 ⁻⁴)
⁸¹ Kr	IT	13.10(3) s	99.9975(4)	1	190.46(0.072)
⁸³ Kr	IT	1.83(2) h	100	2	9.4050(0.122)
⁸⁵ Kr	β^-	4.480(8) h	78.6(4)	6	151.195(0.0385)
⁸⁵ Kr	IT	4.480(8) h	21.4(4)	1	304.870(0.0071)
⁸⁷ Kr	β^-	76.3(6) m	100	28	402.587(0.000257), 2554.80(4.78x10 ⁻⁵), 845.44(3.80x10 ⁻⁵)
⁸⁶ Rb	β^-	18.631(18) d	99.9948(5)	1	1076.64(0.0301)
⁸⁶ Rb	IT	1.017(3) m	100	1	555.61(0.0407)
⁸⁸ Rb	β^-	17.78(11) m	100	30	1836.00(0.00714), 898.03(0.00468)
⁸⁵ Sr	EC	67.63(4) m	13.4(4)	1	150.75(0.00046)
⁸⁵ Sr	IT	67.63(4) m	86.6(4)	2	231.68(0.0029)
⁸⁷ Sr	IT	2.803(3) h	99.70(8)	1	388.526(0.0785)
⁹⁰ Y	IT	3.19(6) h	99.9979(2)	2	202.53(0.0018), 479.60(0.0016)
⁹⁷ Zr	β^-	16.744(11) h	100	31	743.36(0.00101)
⁹⁴ Nb	β^-	6.26(1) m	0.50(6)	1	871.1(0.00390)
⁹⁴ Nb	IT	6.26(1) m	99.50(6)	1	40.887(0.000574)
¹⁰¹ Mo	β^-	14.61(3) m	100	163	590.10(0.00380), 191.920(0.00360), 1012.47(0.00258)
⁹⁹ Mo	β^-	65.94(1) h	100	30	140.5110(0.0276), 739.500(0.00405)
¹⁰³ Ru	IT	1.69(7) ms	100	2	210.519(0.033)
¹⁰⁵ Ru	β^-	4.44(2) h	100	84	724.30(0.0760), 469.37(0.0281), 676.36(0.0251)
¹⁰⁴ Rh	β^-	42.3(4) s	99.55	14	555.81(3.14)
¹⁰⁴ Rh	IT	4.34(5) m	99.87(1)	4	51.50(5.2)
¹⁰⁷ Pd	IT	21.3() s	100	1	214.9(0.0024)
¹⁰⁹ Pd	IT	4.69(1) m	100	1	188.9900(0.0273)
¹¹¹ Pd	β^-	23.4(2) m	100	76	580.00(1.90x10 ⁻⁴), 70.43(1.68x10 ⁻⁴), 1459.0(1.25x10 ⁻⁴)
¹¹¹ Pd	IT	5.5(1) h	73(3)	1	172.18(0.0015)
¹⁰⁸ Ag	β^-	2.37(1) m	97.15(20)	1	632.98(0.369)
¹⁰⁸ Ag	EC	2.37(1) m	2.85(20)	11	433.96(0.0990), 618.86(0.052)
¹¹⁰ Ag	β^-	24.6(2) s	99.70(6)	13	657.50(1.86)
¹¹⁴ In	β^-	71.9(1) s	99.50(15)	1	1299.83(2.4x10 ⁻⁴)
¹¹⁴ In	IT	43.1(6) ms	100	1	311.646(0.13)
¹¹⁶ In	β^-	54.41(6) m	100	30	1293.54(131), 1097.30(87.3), 416.86(43.0)
¹¹⁶ In	IT	2.18(4) s	100	1	162.393(15.8)
¹¹⁶ In	β^-	14.10(3) s	100	10	1293.4(0.470), 463.3(0.0930)
¹²³ Sn	β^-	40.06(1) m	100	5	160.32(0.00580)
¹²⁵ Sn	β^-	9.52(5) m	100	23	331.90(0.00830)
¹²² Sb	β^-	2.7238(2) d	97.59(12)	7	564.24(2.70)
¹²² Sb	IT	4.191(3) m	97.59(12)	3	61.4130(0.0200), 76.0590(0.0081)
¹²⁴ Sb	β^-	93(5) s	25(5)	4	498.40(0.068), 645.82(0.068), 602.72(0.068)
¹²⁴ Sb	IT	93(5) s	75(5)	1	10.8630(1.40x10 ⁻⁵)
¹²⁴ Sb	IT	20.2(2) m	100	2	10.8630(6.04x10 ⁻⁶), 25.9820(4.45x10 ⁻⁶)
¹³¹ Te	β^-	25.0(1) m	100	78	149.716(0.0630), 452.3230(0.0168)
¹³¹ Te	β^-	30(2) h	77.8(16)	171	773.67(0.00355), 852.21(0.00192), 793.75(0.00129)
¹³¹ Te	IT	30(2) h	22.2(16)	1	182.250(0.00026)
¹²⁸ I	β^-	24.99(2) m	93.1(6)	7	442.901(0.595)
¹²⁸ I	EC	24.99(2) m	6.9(1)	1	743.50(0.0051)
¹²⁵ Xe	IT	56.9(9) s	100	2	111.3(0.0027), 141.4(0.00091)
¹²⁹ Xe	IT	8.88(2) d	100	2	39.578(0.00069), 196.56(0.00042)
¹³⁷ Xe	β^-	3.818(13) m	100	83	455.490(0.00350)
¹³⁴ Cs	IT	2.903(8) h	100	3	127.500(0.310)
¹³¹ Ba	IT	14.6(2) m	100	2	108.45(0.00150)

Isotope	Mode	Half-life	%BR	N_γ	E_γ , $\sigma_\gamma^z(E_\gamma)$ for principal decay gammas
¹³³ Ba	IT	38.9(1) h	99.99	2	275.925(9.00x10 ⁻⁵)
¹³⁵ Ba	IT	28.7(2) h	100	1	268.218(0.00060)
¹³⁶ Ba	IT	0.3084(19) s	100	3	1048.073(0.000919), 818.514(0.000916), 163.920(0.000280)
¹³⁷ Ba	IT	2.552(1) m	100	1	661.657(0.00071)
¹³⁹ Ba	β ⁻	83.06(3) m	100	28	165.8570(0.074)
¹⁴⁰ Ba	β ⁻	12.752(3) d	100	16	537.261(0.066), 29.966(0.0381), 162.660(0.0168)
¹³⁸ La(nat)	β ⁻	1.05(3) x 10 ¹¹ y	33.6(5)	1	788.7(0.273 cps/g)
¹³⁸ La(nat)	EC	1.05(3) x 10 ¹¹ y	66.4(5)	1	1435.795(0.539 cps/g)
¹⁴⁰ La	β ⁻	1.6781(7) d	100	38	1596.21(5.84), 487.021(2.79), 815.772(1.43)
¹³⁷ Ce	EC	9.0(3) h	100	20	447.15(1.30x10 ⁻⁴), 10.61(5.6x10 ⁻⁵), 436.59(1.86x10 ⁻⁵)
¹³⁷ Ce	IT	34.4(3) h	99.22(3)	1	254.29(2.0x10 ⁻⁴)
¹³⁹ Ce	IT	54.8(10) s	100	1	754.24(3.5x10 ⁻⁵)
¹⁴² Pr	β ⁻	19.12(4) h	99.98	2	1575.6(0.426)
¹⁴⁹ Nd	β ⁻	1.728(1) h	100	213	211.309(0.0370), 114.314(0.0274), 270.166(0.0153)
¹⁵¹ Nd	β ⁻	12.44(7) m	100	471	116.800(0.0262), 255.680(0.0099), 1180.890(0.0089)
¹⁵⁵ Sm	β ⁻	22.3(2) m	100	50	104.320(1.43)
¹⁵² Eu	IT	96(1) m	100	4	89.847(1.30)
¹⁵⁵ Gd	IT	31.97(3) ms	100	3	86.545(0.00074), 13.47(7.6x10 ⁻⁵)
¹⁵⁹ Gd	β ⁻	18.56(8) h	100	20	363.5430(0.063), 58.000(0.0118)
¹⁶¹ Gd	β ⁻	3.66(5) m	100	98	360.940(0.199), 314.920(0.075), 102.315(0.046)
¹⁵⁷ Dy	EC	8.14(4) h	100	25	326.16(0.018)
¹⁶⁵ Dy	β ⁻	2.334(6) h	100	55	94.700(10.6), 361.680(2.50), 633.415(1.69)
¹⁶⁵ Dy	β ⁻	1.257(6) m	2.24(11)	11	515.467(6.93), 361.471(2.42), 153.803(1.10)
¹⁶⁵ Dy	IT	1.257(6) m	97.76(11)	1	108.159(13.6)
¹⁶⁶ Ho	β ⁻	26.80(2) h	100	14	80.574(3.87), 1379.40(0.537)
¹⁶⁷ Er	IT	2.269(6) s	100	1	207.801(2.15)
¹⁷¹ Er	β ⁻	7.516(2) h	100	58	308.291(0.559), 295.901(0.251), 111.621(0.178)
¹⁶⁹ Yb	IT	46(2) s	100	1	24.200(5.6x10 ⁻⁶)
¹⁷⁵ Yb	β ⁻	4.185(1) d	100	6	396.329(1.42), 282.522(0.666), 113.805(0.417)
¹⁷⁵ Yb	IT	68.2(3) ms	100	1	514.868(9.0)
¹⁷⁷ Yb	β ⁻	1.911(3) h	100	24	150.6(0.073), 1080.20(0.0201), 1241.20(0.0125)
¹⁷⁷ Yb	IT	6.41(3) s	100	2	104.50(0.029), 227.02(0.0047)
¹⁷⁶ Lu(nat)	β ⁻	4.00(22) x 10 ¹⁰ y	100	4	306.84(45.2 cps/g), 201.83(37.9 cps/g)
¹⁷⁷ Lu	β ⁻	6.73(1) d	100	6	208.366(6.0), 112.9500(3.47)
¹⁷⁸ Hf	IT	4.0(2) s	100	6	426.380(0.175), 325.559(0.170), 213.439(0.1470)
¹⁷⁹ Hf	IT	18.67(4) s	100	2	214.341(16.3)
¹⁸⁰ Hf	IT	5.5(1) h	99.7(1)	6	332.275(0.0586), 443.163(0.0509), 215.426(0.0506)
¹⁸² Ta	IT	15.84(10) m	100	5	171.580(0.00540), 146.7740(0.00408), 184.951(0.00268)
¹⁸³ W	IT	5.2(3) s	100	6	107.932(0.00438), 99.079(0.00189), 52.595(0.00157)
¹⁸⁵ W	IT	1.67(3) m	100	12	65.86(3.44x10 ⁻⁵), 131.550(2.56x10 ⁻⁵), 173.680(1.93x10 ⁻⁵)
¹⁸⁷ W	β ⁻	23.72(6) h	100	74	685.73(3.24), 479.550(2.59), 72.002(1.32)
¹⁸⁶ Re	β ⁻	3.7183(11) d	92.53(10)	8	137.157(5.29)
¹⁸⁶ Re	EC	3.7183(11) d	7.47(10)	1	122.640(0.250)
¹⁸⁸ Re	β ⁻	17.005(4) h	100	51	155.041(7.16)
¹⁸⁸ Re	IT	18.6(1) m	100	5	63.582(0.279), 105.862(0.140), 92.4640(0.066)
¹⁹¹ Os	IT	13.10(5) h	100	1	74.380(0.0032)
¹⁹³ Os	β ⁻	30.11(1) h	100	63	138.92(0.0467), 460.49(0.0432), 73.040(0.035)
¹⁹² Ir	IT	1.45(5) m	99.9825	1	56.719(0.085)
¹⁹⁴ Ir	β ⁻	19.28(13) h	100	65	328.448(9.1), 293.541(1.76)
¹⁹⁴ Ir	IT	31.85(24) ms	100	9	112.231(0.302), 84.2840(0.168)
¹⁹⁷ Pt	β ⁻	19.8915(19) h	100	3	77.35(0.031), 191.437(0.00660)
¹⁹⁷ Pt	IT	95.41(18) m	96.7(4)	2	346.50(0.00132)
¹⁹⁹ Pt	β ⁻	30.8(4) m	100	42	542.98(0.0390), 493.75(0.0147), 317.03(0.0130)

Isotope	Mode	Half-life	%BR	N_γ	$E_\gamma, \sigma_\gamma^z(E_\gamma)$ for principal decay gammas
¹⁹⁹ Pt	IT	13.6(4) s	100	2	391.93(0.0212)
¹⁹⁸ Au	β^-	2.69517(21) d	100	3	411.8(94.29)
¹⁹⁷ Hg	EC	23.8(1) h	8.6(7)	5	279.00(0.00330)
¹⁹⁷ Hg	IT	23.8(1) h	91.4(7)	2	133.98(0.0155)
¹⁹⁹ Hg	IT	42.6(2) m	100	3	158.30(0.000940), 374.10(2.47x10 ⁻⁴)
²⁰⁵ Hg	β^-	5.2(1) m	100	13	203.750(0.00064)
²⁰⁶ Tl	β^-	4.200(17) m	100	2	803.30(3.5x10 ⁻⁶)
²⁰⁷ Pb	IT	0.806(6) s	100	2	569.7(0.0014), 1063.662(0.0013)
²³² Th(nat)	α	14.05(6) x 10 ⁹ y	100	2	63.810(10.7 cps/g)
²³⁵ U(nat)	α	7.038(5) x 10 ⁸ y	100	49	185.715(329 cps/g), 143.760(63.0 cps/g)
²³⁹ Np	β^-	2.3565(4) d	100	36	106.1230(0.723), 277.5990(0.382), 228.1830(0.286)
²³⁹ U	β^-	23.45(2) m	100	97	74.664(1.30)

Table 7.3 Adopted Prompt and Decay Gamma Rays from Thermal Neutron Capture for all Elements.

^A Z	E _γ -keV	σ _γ ^z (E _γ)-barns	k ₀	^A Z	E _γ -keV	σ _γ ^z (E _γ)-barns	k ₀
Hydrogen (Z=1), At.Wt.=1.00794(7), σ_γ^z=0.3326(7)				Fluorine (Z=9), At.Wt.=18.9984032(5), σ_γ^z=0.0096(5)			
¹ H	2223.24835(9)	0.3326(7)	1.0000(21)	¹⁶ O	1087.75(6)	1.58(7)E-4	2.99(13)E-5
² H	6250.243(3)	0.000519(7)(a)	0.001560(21)	¹⁷ O	1981.95(9)	2.0(4)E-7	3.8(8)E-8
Helium (Z=2), At.Wt.=4.002602(2), σ_γ^z=4.2E-11(12)				¹⁶ O	2184.42(7)	1.64(7)E-4	3.11(13)E-5
³ He	20520.46	4.2(12)E-11	3.2(9)E-11	¹⁶ O	3272.02(8)	3.53(23)E-5	6.7(4)E-6
Lithium (Z=3), At.Wt.=6.941(2), σ_γ^z=0.045(3)				Carbon (Z=6), At.Wt.=12.0107(8), σ_γ^z=0.00351(5)			
σ_α^z(⁶Li)=71.3(5)				¹² C	1261.765(9)	0.00124(3)	0.000313(8)
⁶ Li	477.595(3)	0.00153(8)	0.00067(4)	¹² C	3683.920(9)	0.00122(3)	0.000308(8)
⁷ Li	980.53(7)	0.00415(13)	0.00181(6)	¹² C	4945.301(3)	0.00261(5)	0.000659(13)
⁷ Li	1051.90(7)	0.00414(12)	0.00181(5)	¹³ C	8174.04(18)	1.09(6)E-5	2.75(15)E-6
⁷ Li	2032.30(4)	0.0381(8)	0.0166(4)	Nitrogen (Z=7), At.Wt.=14.0067(2), σ_γ^z=0.0795(14)			
⁶ Li	6768.81(4)	0.00151(9)	0.00066(4)	σ_p^z(¹⁴N)=1.82(3)			
⁶ Li	7245.91(4)	0.00247(14)	0.00108(6)	¹⁴ N	583.59(3)	0.000429(14)	9.3(3)E-5
Beryllium (Z=4), At.Wt.=9.012182(3), σ_γ^z=0.0088(4)				¹⁴ N	1678.281(14)	0.0063(3)	0.00136(7)
⁹ Be	853.630(12)	0.00208(24)	0.00070(8)	¹⁴ N	1681.24(5)	0.00129(8)	0.000279(17)
⁹ Be	2590.014(19)	0.00191(15)	0.00064(5)	¹⁴ N	1853.922(19)	0.000508(10)	1.099(22)E-4
⁹ Be	3367.448(25)	0.00285(22)	0.00096(7)	¹⁴ N	1884.821(16)	0.01470(18)	0.00318(4)
⁹ Be	3443.406(20)	0.00098(7)	0.000330(24)	¹⁴ N	1988.632(20)	0.00289(16)	6.3(4)E-5
⁹ Be	5956.53(3)	1.46(12)E-4	4.9(4)E-5	¹⁴ N	1999.690(16)	0.00323(4)	0.000699(9)
⁹ Be	6809.61(3)	0.0058(5)	0.00195(17)	¹⁴ N	2520.457(17)	0.00441(24)	0.00095(5)
Boron (Z=5), At.Wt.=10.811(7), σ_γ^z=0.104(20)				¹⁴ N	2830.789(17)	0.00134(3)	0.000290(7)
σ_α^z(¹⁰B)=764(25)				¹⁴ N	3013.482(21)	0.00057(5)	1.23(11)E-4
¹⁰ B(n,α)	477.595(3)	716(25)	201(7)	¹⁴ N	3531.981(15)	0.0071(4)	0.00154(9)
¹⁰ B	6739.67(17)	0.0113(10)	0.0032(3)	¹⁴ N	3677.732(13)	0.0115(6)	0.00249(13)
Oxygen (Z=8), At.Wt.=15.9994(3), σ_γ^z=1.90E-4(19)				¹⁴ N	3855.577(19)	0.000626(16)	1.35(4)E-4
(a) Total Deuterium isotopic cross section				¹⁴ N	3884.242(18)	0.000436(13)	9.4(3)E-5
¹⁶ O	870.68(6)	1.77(11)E-4	3.35(21)E-5	¹⁴ N	4508.731(12)	0.0132(7)	0.00286(15)
				¹⁴ N	5269.159(13)	0.0236(3)	0.00511(7)
				¹⁴ N	5297.821(15)	0.01680(23)	0.00363(5)
				¹⁴ N	5533.395(14)	0.0155(8)	0.00335(17)
				¹⁴ N	5562.057(13)	0.0084(5)	0.00182(11)
				¹⁵ N	6128.63(4)d	5.90(12)E-8	1.28E-8[100%]
				¹⁴ N	6322.428(12)	0.01450(22)	0.00314(5)
				¹⁴ N	7298.983(17)	0.00746(12)	0.00161(3)
				¹⁴ N	8310.161(19)	0.00330(6)	0.000714(13)
				¹⁴ N	9148.98(5)	0.00129(6)	0.000279(13)
				¹⁴ N	10829.120(12)	0.0113(8)	0.00244(17)
				¹⁹ F	166.700(20)	0.000413(18)	6.6(3)E-5
				¹⁹ F	325.606(24)	4.0(3)E-5	6.4(5)E-6
				¹⁹ F	556.40(4)	2.01(8)E-4	3.21(13)E-5
				¹⁹ F	583.561(16)	0.00356(12)	0.000568(19)
				¹⁹ F	656.006(18)	0.00197(7)	0.000314(11)
				¹⁹ F	661.647(21)	2.24(14)E-4	3.57(22)E-5
				¹⁹ F	662.25(10)	1.02(15)E-4	1.63(24)E-5
				¹⁹ F	665.207(18)	0.00149(6)	2.38(10)E-4
				¹⁹ F	822.700(19)	2.20(9)E-4	3.51(14)E-5
				¹⁹ F	978.19(5)	6.8(6)E-5	1.08(10)E-5
				¹⁹ F	983.538(20)	0.00116(4)	1.85(6)E-4
				¹⁹ F	1045.98(3)	1.79(8)E-4	2.86(13)E-5
				¹⁹ F	1056.776(17)	0.00095(3)	1.52(5)E-4
				¹⁹ F	1148.077(20)	0.000258(12)	4.12(19)E-5
				¹⁹ F	1187.725(25)	4.5(3)E-5	7.2(5)E-6
				¹⁹ F	1282.15(4)	8.5(5)E-5	1.36(8)E-5
				¹⁹ F	1309.126(17)	0.00076(3)	1.21(5)E-4
				¹⁹ F	1371.520(24)	1.44(7)E-4	2.30(11)E-5
				¹⁹ F	1387.901(20)	0.00082(3)	1.31(5)E-4
				¹⁹ F	1392.191(23)	8.3(5)E-5	1.32(8)E-5
				¹⁹ F	1542.498(20)	0.000271(11)	4.32(18)E-5
				¹⁹ F	1633.53(3)d	0.0096(4)	0.00153[100%]
				¹⁹ F	1644.538(25)	7.3(6)E-5	1.16(10)E-5
				¹⁹ F	1843.688(20)	0.000600(23)	9.6(4)E-5
				¹⁹ F	1935.52(3)	7.3(5)E-5	1.16(8)E-5
				¹⁹ F	1970.726(20)	8.5(6)E-5	1.36(10)E-5
				¹⁹ F	2009.52(6)	4.6(4)E-5	7.3(6)E-6
				¹⁹ F	2043.858(20)	7.0(4)E-5	1.12(6)E-5
				¹⁹ F	2143.248(21)	1.95(8)E-4	3.11(13)E-5
				¹⁹ F	2179.091(20)	8.9(6)E-5	1.42(10)E-5
				¹⁹ F	2194.159(21)	1.32(6)E-4	2.11(10)E-5
				¹⁹ F	2229.75(9)	5.3(5)E-5	8.5(8)E-6
				¹⁹ F	2255.83(3)	8.5(5)E-5	1.36(8)E-5
				¹⁹ F	2309.929(25)	4.5(3)E-5	7.2(5)E-6
				¹⁹ F	2324.12(3)	1.18(5)E-4	1.88(8)E-5
				¹⁹ F	2427.82(3)	1.89(8)E-4	3.01(13)E-5
				¹⁹ F	2431.084(10)	0.000392(24)	6.3(4)E-5
				¹⁹ F	2431.425(19)	7(3)E-5	1.1(5)E-5
				¹⁹ F	2447.574(21)	1.44(7)E-4	2.30(11)E-5
				¹⁹ F	2469.34(3)	1.94(9)E-4	3.09(14)E-5
				¹⁹ F	2504.658(25)	3.8(4)E-5	6.1(6)E-6
				¹⁹ F	2519.02(3)	6.8(5)E-5	1.08(8)E-5
				¹⁹ F	2529.212(18)	0.00061(3)	9.7(5)E-5
				¹⁹ F	2529.553(18)	9(3)E-5	1.4(5)E-5
				¹⁹ F	2623.16(3)	4.5(3)E-5	7.2(5)E-6
				¹⁹ F	2636.09(3)	9.6(5)E-5	1.53(8)E-5
				¹⁹ F	2655.70(3)	7.6(6)E-5	1.21(10)E-5
				¹⁹ F	2920.96(3)	9.6(5)E-5	1.53(8)E-5
				¹⁹ F	2930.284(21)	8.5(5)E-5	1.36(8)E-5
				¹⁹ F	2965.854(22)	9.3(5)E-5	1.48(8)E-5
				¹⁹ F	3014.568(10)	0.000405(15)	6.46(24)E-5
				¹⁹ F	3025.10(3)	8.4(9)E-5	1.34(14)E-5
				¹⁹ F	3051.435(20)	0.000297(12)	4.74(19)E-5
				¹⁹ F	3074.78(3)	1.86(8)E-4	2.97(13)E-5
				¹⁹ F	3112.693(18)	2.36(9)E-4	3.76(14)E-5
				¹⁹ F	3220.00(3)	6.1(4)E-5	9.7(6)E-6
				¹⁹ F	3293.23(4)	3.8(8)E-5	6.1(13)E-6
				¹⁹ F	3387.58(9)	6.1(5)E-5	9.7(8)E-6
				¹⁹ F	3488.064(18)	0.00073(3)	1.16(5)E-4
				¹⁹ F	3586.186(10)	0.000286(13)	4.56(21)E-5

^A Z	E _γ -keV	σ _γ ^Z (E _γ)-barns	k ₀	^A Z	E _γ -keV	σ _γ ^Z (E _γ)-barns	k ₀
¹⁹ F	3589.45(3)	1.79(8)E-4	2.86(13)E-5	²³ Na	781.435(11)	0.0175(5)	0.00231(7)
¹⁹ F	3679.79(3)	8.7(8)E-5	1.39(13)E-5	²³ Na	835.292(18)	0.0109(3)	0.00144(4)
¹⁹ F	3741.46(3)	5.7(5)E-5	9.1(8)E-6	²³Na 869.210(9)	0.1080(13)	0.01424(17)	
¹⁹ F	3823.093(24)	1.07(6)E-4	1.71(10)E-5	²³Na 874.389(6)	0.0760(11)	0.01002(15)	
¹⁹F 3964.872(20)	0.000435(18)	6.9(3)E-5		²³ Na	886.749(11)	0.00402(16)	0.000530(21)
¹⁹ F	4046.504(23)	6.0(16)E-5	1.0(3)E-5	²³ Na	1006.23(4)	0.00370(18)	0.000488(24)
¹⁹ F	4081.71(3)	5.6(4)E-5	8.9(6)E-6	²³ Na	1150.002(17)	0.00528(21)	0.00070(3)
¹⁹ F	4094.85(10)	5.1(17)E-5	8(3)E-6	²³ Na	1282.764(8)	0.0055(3)	0.00073(4)
¹⁹ F	4173.527(23)	1.66(7)E-4	2.65(11)E-5	²³ Na	1322.262(14)	0.0062(3)	0.00082(4)
¹⁹ F	4200.68(4)	1.11(6)E-4	1.77(10)E-5	²³ Na	1337.73(4)	0.00313(20)	0.00041(3)
¹⁹ F	4245.68(3)	9.5(5)E-5	1.52(8)E-5	²³ Na	1344.607(11)	0.0217(5)	0.00286(7)
¹⁹ F	4335.08(4)	4.6(4)E-5	7.3(6)E-6	²³Na 1368.66(3)d	0.530(8)	0.0699[2.3%]	
¹⁹F 4556.817(20)	0.000517(23)	8.2(4)E-5		²³ Na	1373.751(8)	0.0079(19)	0.00104(25)
¹⁹ F	4708.007(20)	5.1(4)E-5	8.1(6)E-6	²³ Na	1504.92(7)	0.00293(23)	0.00039(3)
¹⁹ F	4735.16(4)	5.6(4)E-5	8.9(6)E-6	²³ Na	1562.470(21)	0.00256(20)	0.00034(3)
¹⁹ F	4756.957(23)	1.86(9)E-4	2.97(14)E-5	²³ Na	1620.49(4)	0.00294(22)	0.00039(3)
¹⁹ F	4951.90(3)	6.2(6)E-5	9.9(10)E-6	²³ Na	1633.080(23)	0.0074(4)	0.00098(5)
¹⁹F 5033.530(23)	0.00063(3)	1.00(5)E-4		²³Na 1636.293(21)	0.0250(7)	0.00330(9)	
¹⁹F 5279.360(20)	0.000421(20)	6.7(3)E-5		²³ Na	1712.43(20)	0.0112(6)	0.00148(8)
¹⁹ F	5291.420(19)	2.35(11)E-4	3.75(18)E-5	²³ Na	1885.421(14)	0.0039(3)	0.00051(4)
¹⁹ F	5360.986(21)	1.17(5)E-4	1.87(8)E-5	²³ Na	1899.06(4)	0.0081(4)	0.00107(5)
¹⁹F 5543.713(10)	0.000407(17)	6.5(3)E-5		²³ Na	1899.86(3)	0.0036(16)	0.00047(21)
¹⁹ F	5554.51(3)	5.1(4)E-5	8.1(6)E-6	²³ Na	1914.44(3)	0.00606(21)	0.00080(3)
¹⁹ F	5616.933(23)	1.41(8)E-4	2.25(13)E-5	²³ Na	1928.16(4)	0.00480(19)	0.000633(25)
¹⁹ F	5935.179(20)	9.1(8)E-5	1.45(13)E-5	²³ Na	1928.37(4)	0.0055(5)	0.00073(7)
¹⁹F 6016.802(16)	0.00094(4)	1.50(6)E-4		²³ Na	1950.112(23)	0.0087(3)	0.00115(4)
¹⁹F 6600.175(16)	0.00096(3)	1.53(5)E-4		²³ Na	2019.50(8)	0.0025(3)	0.00033(4)
Neon (Z=10), At. Wt.=20.1797(6), σ_γ^Z=0.039(4)				²³Na 2025.139(22)	0.0341(8)	0.00450(11)	
²⁰ Ne	350.72(6)	0.0198(4)	0.00297(6)	²³ Na	2027.104(25)	0.0038(5)	0.00050(7)
²² Ne	439.986d	0.001400(5)	2.102E-4[99%]	²³ Na	2030.318(23)	0.0219(7)	0.00289(9)
²⁰ Ne	768.55(7)	2.5(4)E-4	3.8(6)E-5	²³ Na	2071.78(3)	0.0059(3)	0.00078(4)
²⁰ Ne	964.41(7)	0.00029(11)	4.4(17)E-5	²³Na 2208.40(3)	0.0259(9)	0.00341(12)	
²²Ne 1017.00(20)	0.0030(5)	0.00045(8)		²³ Na	2361.026(21)	0.0084(3)	0.00111(4)
²⁰Ne 1071.34(7)	0.0054(4)	0.00081(6)		²³ Na	2397.433(25)	0.0069(4)	0.00091(5)
²¹ Ne	1274.542(7)	0.0018(5)	0.00027(8)	²³Na 2414.457(21)	0.0237(5)	0.00312(7)	
²² Ne	1364.8(3)	0.00091(12)	1.37(18)E-4	²³ Na	2505.439(21)	0.0167(5)	0.00220(7)
²² Ne	1822.40(20)	0.00052(5)	7.8(8)E-5	²³Na 2517.81(3)	0.0699(15)	0.00921(20)	
²⁰Ne 1931.08(6)	0.00591(22)	0.00089(3)		²³ Na	2595.49(3)	0.0052(3)	0.00069(4)
²²Ne 1979.89(6)	0.00306(17)	0.00046(3)		²³ Na	2630.66(3)	0.00289(14)	0.000381(18)
²² Ne	2013.8(4)	0.00040(5)	6.0(8)E-5	²³ Na	2715.87(3)	0.00306(16)	0.000403(21)
²⁰Ne 2035.67(20)	0.0245(25)	0.0037(4)		²³Na 2752.271(23)	0.0654(12)	0.00862(16)	
²¹ Ne	2082.5(4)	0.0011(3)	1.7(5)E-4	²³Na 2754.13(6)d	0.530(8)	0.0699[2.3%]	
²¹ Ne	2165.9(7)	0.00084(21)	1.3(3)E-4	²³ Na	2763.17(7)	0.0053(12)	0.00070(16)
²² Ne	2203.58(6)	0.00238(23)	0.00036(4)	²³ Na	2808.468(22)	0.0168(7)	0.00221(9)
²⁰ Ne	2437.84(25)	0.00036(7)	5.4(11)E-5	²³ Na	2860.355(20)	0.0177(5)	0.00233(7)
²⁰Ne 2793.94(5)	0.0090(11)	0.001352(17)		²³ Na	2865.534(22)	0.0130(4)	0.00171(5)
²² Ne	2819.22(16)	0.00052(5)	7.8(8)E-5	²³ Na	2904.89(3)	0.0059(3)	0.00078(4)
²⁰Ne 2895.32(10)	0.00252(7)	0.000378(11)		²³ Na	2940.91(3)	0.00347(18)	0.000457(24)
²¹ Ne	2987.8(5)	0.00086(22)	1.3(3)E-4	²³ Na	2981.97(3)	0.0142(6)	0.00187(8)
²¹ Ne	3181.8(16)	0.00048(12)	7.2(18)E-5	²³ Na	3025.99(4)	0.0146(6)	0.00192(8)
²² Ne	3220.42(16)	0.00057(23)	9(4)E-5	²³ Na	3092.50(5)	0.0025(4)	0.00033(5)
²⁰ Ne	3971.98(15)	0.00039(3)	5.9(5)E-5	²³ Na	3093.79(8)	0.00280(20)	0.00037(3)
²¹ Ne	4018.3(5)	0.00090(23)	1.4(4)E-4	²³ Na	3096.78(3)	0.0199(7)	0.00262(9)
²⁰Ne 4374.13(6)	0.01910(22)	0.00287(3)		²³ Na	3099.99(3)	0.0160(9)	0.00211(12)
²¹ Ne	4634.83	0.00042(11)	6.3(17)E-5	²³ Na	3116.97(4)	0.00523(24)	0.00069(3)
²¹ Ne	4840.1(5)	0.00038(10)	5.7(15)E-5	²³ Na	3209.59(10)	0.00381(20)	0.00050(3)
²⁰ Ne	5688.97(6)	0.00214(3)	0.000321(5)	²³ Na	3214.22(4)	0.0054(4)	0.00071(5)
²⁰ Ne	6760.06(6)	0.002100(25)	0.000315(4)	²³ Na	3277.32(10)	0.00377(17)	0.000497(22)
²¹ Ne	9087.3(5)	0.00028(7)	4.2(11)E-5	²³ Na	3369.94(4)	0.0133(4)	0.00175(5)
Sodium (Z=11), At. Wt.=22.989770(2), σ_γ^Z=0.530(5)				²³ Na	3409.39(3)	0.00237(11)	0.000312(15)
²³Na 90.9920(10)	0.235(3)	0.0310(4)		²³ Na	3413.97(3)	0.00441(18)	0.000581(24)
²³Na 472.202(9)d	0.478(4)	0.0630[100%]		²³ Na	3504.94(3)	0.00676(23)	0.00089(3)
²³ Na	499.381(5)	0.0143(3)	0.00189(4)	²³ Na	3546.00(3)	0.00454(22)	0.00060(3)
²³ Na	501.347(13)	0.00314(13)	0.000414(17)	²³Na 3587.460(25)	0.0596(11)	0.00786(15)	
²³ Na	563.1920(20)	0.0085(3)	0.00112(4)	²³ Na	3643.655(20)	0.0067(3)	0.00088(4)
²³ Na	711.967(10)	0.00430(22)	0.00057(3)	²³ Na	3878.10(3)	0.0218(6)	0.00287(8)
²³ Na	778.221(9)	0.0058(3)	0.00076(4)	²³Na 3981.450(25)	0.0677(11)	0.00892(15)	
				²³ Na	4187.49(3)	0.0073(5)	0.00096(7)

^A Z	E _γ -keV	σ _γ ^Z (E _γ)-barns	k ₀	^A Z	E _γ -keV	σ _γ ^Z (E _γ)-barns	k ₀
²³ Na	5113.007(16)	0.00250(14)	0.000330(18)	²⁷ Al	1073.94(4)	0.00100(4)	1.12(5)E-4
²³ Na	5612.274(16)	0.0026(11)	0.00034(15)	²⁷ Al	1102.06(4)	0.00103(4)	1.16(5)E-4
²³ Na	5614.239(18)	0.005(3)	0.0007(4)	²⁷ Al	1125.289(14)	0.00083(4)	9.3(5)E-5
²³ Na	5617.452(17)	0.016(5)	0.0021(7)	²⁷ Al	1193.476(22)	0.00097(4)	1.09(5)E-4
²³ Na	6395.478(15)	0.1000(20)	0.0132(3)	²⁷ Al	1283.693(12)	0.00222(6)	2.49(7)E-4
Magnesium (Z=12), At. Wt.=24.3050(6), σ_γ^Z=0.0666(13)				²⁷ Al	1342.320(20)	0.00209(6)	2.35(7)E-4
²⁴ Mg	389.670(21)	0.00586(24)	0.00073(3)	²⁷ Al	1408.344(9)	0.00640(13)	0.000719(15)
²⁴ Mg	585.00(3)	0.0314(11)	0.00392(14)	²⁷ Al	1526.246(12)	0.00339(9)	0.000381(10)
²⁶ Mg	843.71(3)d	0.00298(14)	0.000372[78%]	²⁷ Al	1589.62(3)	0.00247(7)	0.000277(8)
²⁴ Mg	862.96(3)	0.000410(21)	5.1(3)E-5	²⁷ Al	1622.877(18)	0.00989(15)	0.001111(17)
²⁴ Mg	974.66(3)	0.00663(24)	0.00083(3)	²⁷ Al	1705.509(22)	0.00080(5)	9.0(6)E-5
²⁶ Mg	984.88(4)	0.00064(4)	8.0(5)E-5	²⁷ Al	1778.92(3)d	0.232(4)	0.0261[95%]
²⁵ Mg	1003.14(3)	0.00161(6)	2.01(8)E-4	²⁷ Al	1864.33(3)	0.00091(4)	1.02(5)E-4
²⁵ Mg	1129.575(23)	0.00891(25)	0.00111(3)	²⁷ Al	1927.527(25)	0.00262(7)	0.000294(8)
²⁵ Mg	1411.70(3)	0.00130(5)	1.62(6)E-4	²⁷ Al	1983.978(14)	0.00207(8)	2.32(9)E-4
²⁶ Mg	1615.11(4)	0.00070(4)	8.7(5)E-5	²⁷ Al	2108.197(10)	0.00549(11)	0.000617(12)
²⁴ Mg	1712.92(4)	0.00118(7)	1.47(9)E-4	²⁷ Al	2138.833(10)	0.00424(9)	0.000476(10)
²⁵ Mg	1775.31(3)	0.00129(5)	1.61(6)E-4	²⁷ Al	2170.70(3)	0.00082(5)	9.2(6)E-5
²⁵ Mg	1808.668(22)	0.0180(5)	0.00224(6)	²⁷ Al	2255.37(3)	0.00109(5)	1.22(6)E-4
²⁵ Mg	1896.72(3)	0.00094(4)	1.17(5)E-4	²⁷ Al	2271.686(21)	0.00396(10)	0.000445(11)
²⁴ Mg	1978.25(3)	0.00111(5)	1.38(6)E-4	²⁷ Al	2282.794(9)	0.00890(17)	0.001000(19)
²⁵ Mg	2132.67(3)	0.00089(4)	1.11(5)E-4	²⁷ Al	2451.565(11)	0.00106(7)	1.19(8)E-4
²⁵ Mg	2189.57(4)	0.000592(22)	7.4(3)E-5	²⁷ Al	2577.701(12)	0.00412(10)	0.000463(11)
²⁵ Mg	2353.27(4)	0.000447(21)	5.6(3)E-5	²⁷ Al	2590.193(9)	0.00807(16)	0.000906(18)
²⁵ Mg	2426.12(3)	0.000519(20)	6.47(25)E-5	²⁷ Al	2625.859(14)	0.00264(6)	0.000297(7)
²⁴ Mg	2438.54(3)	0.00473(19)	0.000590(24)	²⁷ Al	2709.62(3)	0.00140(7)	1.57(8)E-4
²⁵ Mg	2510.02(4)	0.00058(3)	7.2(4)E-5	²⁷ Al	2821.444(7)	0.00752(15)	0.000845(17)
²⁵ Mg	2523.65(4)	0.00100(4)	1.25(5)E-4	²⁷ Al	2954.47(7)	0.00098(5)	1.10(6)E-4
²⁵ Mg	2541.21(3)	0.00148(7)	1.85(9)E-4	²⁷ Al	3033.896(6)	0.0179(3)	0.00201(3)
²⁴ Mg	2828.172(25)	0.0240(8)	0.00299(10)	²⁷ Al	3265.538(13)	0.00082(6)	9.2(7)E-5
²⁶ Mg	2881.64(3)	0.00272(14)	0.000339(17)	²⁷ Al	3303.146(10)	0.00241(7)	0.000271(8)
²⁵ Mg	2938.159(25)	0.00094(4)	1.17(5)E-4	²⁷ Al	3346.970(13)	0.00111(5)	1.25(6)E-4
²⁴ Mg	3054.00(3)	0.0083(3)	0.00103(4)	²⁷ Al	3391.699(23)	0.00117(5)	1.31(6)E-4
²⁵ Mg	3208.97(4)	0.000398(19)	4.96(24)E-5	²⁷ Al	3465.058(7)	0.0146(3)	0.00164(3)
²⁴ Mg	3301.41(3)	0.00620(24)	0.00077(3)	²⁷ Al	3560.555(8)	0.00206(8)	2.31(9)E-4
²⁵ Mg	3319.65(3)	0.00100(4)	1.25(5)E-4	²⁷ Al	3591.189(8)	0.01000(21)	0.001123(24)
²⁵ Mg	3341.00(4)	0.00046(3)	5.7(4)E-5	²⁷ Al	3708.939(14)	0.00088(8)	9.9(9)E-5
²⁵ Mg	3406.41(16)	0.0014(5)	1.7(6)E-4	²⁷ Al	3789.326(12)	0.00191(8)	2.15(9)E-4
²⁴ Mg	3413.10(3)	0.00401(16)	0.000500(20)	²⁷ Al	3823.909(23)	0.00114(7)	1.28(8)E-4
²⁵ Mg	3551.19(3)	0.00109(4)	1.36(5)E-4	²⁷ Al	3849.111(8)	0.00699(17)	0.000785(19)
²⁶ Mg	3561.29(3)	0.00249(12)	0.000310(15)	²⁷ Al	3875.487(8)	0.00618(14)	0.000694(16)
²⁴ Mg	3691.02(3)	0.00068(4)	8.5(5)E-5	²⁷ Al	4015.658(13)	0.00166(7)	1.86(8)E-4
²⁵ Mg	3744.00(3)	0.00136(5)	1.70(6)E-4	²⁷ Al	4133.407(7)	0.0149(3)	0.00167(3)
²⁵ Mg	3810.13(4)	0.00097(4)	1.21(5)E-4	²⁷ Al	4259.534(7)	0.0153(3)	0.00172(3)
²⁵ Mg	3831.480(24)	0.00418(14)	0.000521(17)	²⁷ Al	4377.618(12)	0.00103(8)	1.16(9)E-4
²⁶ Mg	3843.00(5)	0.00033(3)	4.1(4)E-5	²⁷ Al	4428.414(13)	0.00185(8)	2.08(9)E-4
²⁴ Mg	3916.84(3)	0.0320(11)	0.00399(14)	²⁷ Al	4660.043(5)	0.00605(16)	0.000680(18)
²⁵ Mg	4216.38(3)	0.00145(5)	1.81(6)E-4	²⁷ Al	4690.676(5)	0.01090(24)	0.00122(3)
²⁵ Mg	4410.13(3)	0.00067(4)	8.4(5)E-5	²⁷ Al	4733.844(11)	0.0126(3)	0.00142(3)
²⁴ Mg	4528.55(9)	0.00035(3)	4.4(4)E-5	²⁷ Al	4736.92(10)	0.00100(22)	1.12(25)E-4
²⁵ Mg	4602.93(3)	0.000363(17)	4.53(21)E-5	²⁷ Al	4754.377(24)	0.00080(7)	9.0(8)E-5
²⁴ Mg	4766.69(4)	0.000327(22)	4.1(3)E-5	²⁷ Al	4764.477(11)	0.00210(10)	2.36(11)E-4
²⁵ Mg	4967.19(3)	0.00162(7)	2.02(9)E-4	²⁷ Al	4903.113(6)	0.00716(18)	0.000804(20)
²⁵ Mg	5067.14(3)	0.00096(4)	1.20(5)E-4	²⁷ Al	5103.711(8)	0.00097(6)	1.09(7)E-4
²⁵ Mg	5452.025(25)	0.00206(7)	0.000257(9)	²⁷ Al	5134.343(8)	0.00722(23)	0.00081(3)
²⁴ Mg	6354.98(3)	0.00106(6)	1.32(8)E-4	²⁷ Al	5302.642(11)	0.00124(9)	1.39(10)E-4
²⁶ Mg	6442.52(3)	0.00039(4)	4.9(5)E-5	²⁷ Al	5411.077(8)	0.00481(19)	0.000540(21)
²⁵ Mg	6742.14(3)	0.000411(19)	5.12(24)E-5	²⁷ Al	5585.651(11)	0.00279(12)	0.000313(13)
²⁵ Mg	8153.448(21)	0.00285(11)	0.000355(14)	²⁷ Al	5709.853(13)	0.00148(8)	1.66(9)E-4
²⁵ Mg	9282.642(20)	0.000438(18)	5.46(22)E-5	²⁷ Al	5766.296(25)	0.00091(8)	1.02(9)E-4
Aluminum (Z=13), At. Wt.=26.981538(2), σ_γ^Z=0.231(3)				²⁷ Al	6101.529(18)	0.00570(21)	0.000640(24)
²⁷ Al	30.6380(10)	0.0798(20)	0.00896(22)	²⁷ Al	6198.143(11)	0.00210(14)	2.36(16)E-4
²⁷ Al	400.589(25)	0.00141(4)	1.58(5)E-4	²⁷ Al	6316.024(9)	0.00500(20)	0.000562(22)
²⁷ Al	831.426(22)	0.00269(7)	0.000302(8)	²⁷ Al	6440.650(11)	0.00147(8)	1.65(9)E-4
²⁷ Al	865.84(3)	0.00087(3)	9.8(3)E-5	²⁷ Al	6619.73(4)	0.00093(7)	1.04(8)E-4
²⁷ Al	941.75(3)	0.00246(5)	0.000276(6)	²⁷ Al	6710.699(10)	0.00220(12)	2.47(13)E-4
²⁷ Al	982.951(10)	0.00902(14)	0.001013(16)	²⁷ Al	7693.397(4)	0.0081(3)	0.00091(3)
²⁷ Al	1013.588(10)	0.00555(10)	0.000623(11)	²⁷ Al	7724.027(4)	0.0493(15)	0.00554(17)

^A Z	E _γ -keV	σ _γ ^Z (E _γ)-barns	k ₀	^A Z	E _γ -keV	σ _γ ^Z (E _γ)-barns	k ₀
Silicon (Z=14), At.Wt.=28.0855(3), σ_γ^Z=0.172(5)				Sulfur (Z=16), At.Wt.=32.065(5), σ_γ^Z=0.534(10)			
³⁰ Si	752.215(23)	0.00316(10)	0.000341(11)	³¹ P	4199.87(4)	0.0055(3)	0.00054(3)
³⁰ Si	1266.15(10)d	2.5(4)E-6	2.7E-7[12%]	³¹ P	4359.57(3)	0.00195(7)	1.91(7)E-4
²⁸ Si	1273.349(17)	0.0289(6)	0.00312(7)	³¹ P	4364.30(4)	0.0073(3)	0.00071(3)
²⁸ Si	1446.176(22)	0.00134(13)	1.45(14)E-4	³¹ P	4491.00(4)	0.00323(12)	0.000316(12)
²⁸ Si	1867.32(3)	0.00129(14)	1.39(15)E-4	³¹ P	4628.94(4)	0.00082(10)	8.0(10)E-5
²⁸ Si	2092.902(18)	0.0331(6)	0.00357(7)	³¹ P	4661.07(4)	0.00568(21)	0.000556(21)
²⁹ Si	2235.227(22)	0.00250(11)	0.000270(12)	³¹ P	4671.37(3)	0.0194(7)	0.00190(7)
²⁸ Si	2425.767(23)	0.00494(15)	0.000533(16)	³¹ P	4876.87(4)	0.00111(9)	1.09(9)E-4
³⁰ Si	2780.552(22)	0.00241(13)	0.000260(14)	³¹ P	4912.30(5)	0.00114(5)	1.12(5)E-4
³⁰ Si	3054.321(23)	0.00245(14)	0.000264(15)	³¹ P	5194.91(5)	0.00236(23)	2.31(23)E-4
²⁹ Si	3101.19(3)	0.00149(8)	1.61(9)E-4	³¹ P	5265.51(4)	0.0058(4)	0.00057(4)
²⁸ Si	3538.966(22)	0.1190(20)	0.01284(22)	³¹ P	5277.66(6)	0.00188(9)	1.84(9)E-4
²⁸ Si	3660.713(23)	0.00703(21)	0.000759(23)	³¹ P	5699.99(4)	0.00102(4)	9.98(4)E-5
²⁹ Si	3864.900(23)	0.00166(9)	1.79(10)E-4	³¹ P	5705.37(3)	0.00428(16)	0.000419(16)
²⁸ Si	3954.39(3)	0.00449(19)	0.000484(21)	³¹ P	5778.06(4)	0.00152(6)	1.49(6)E-4
²⁸ Si	4933.889(24)	0.1120(23)	0.01209(25)	³¹ P	6785.504(24)	0.0267(15)	0.00261(15)
²⁸ Si	5106.693(22)	0.0064(3)	0.00069(3)	³¹ P	7422.022(25)	0.0082(3)	0.00080(3)
²⁸ Si	6379.801(21)	0.0207(6)	0.00223(7)	³¹ P	7856.48(3)	0.00150(8)	1.47(8)E-4
²⁹ Si	6743.25(3)	0.00170(9)	1.83(10)E-4	Sulfur (Z=16), At.Wt.=32.065(5), σ_γ^Z=0.534(10)			
²⁸ Si	7199.199(23)	0.0125(4)	0.00135(4)	³⁶ S	646.171(14)	4.5(5)E-5	4.3(5)E-6
²⁸ Si	8472.209(23)	0.00381(18)	0.000411(19)	³² S	840.993(13)	0.347(6)	0.0328(6)
Phosphorus (Z=15), At.Wt.=30.973761(2), σ_γ^Z=0.172(6)				³² S	1472.401(14)	0.00870(19)	0.000822(18)
³¹ P	78.083(20)	0.059(3)	0.0058(3)	³⁴ S	1572.333(6)	0.00408(12)	0.000386(11)
³¹ P	512.646(19)	0.079(4)	0.0077(4)	³² S	1697.24(3)	0.01250(25)	0.001181(24)
³¹ P	558.46(7)	0.0010(3)	1.0(3)E-4	³² S	1964.86(3)	0.00659(22)	0.000623(21)
³¹ P	636.663(21)	0.0311(14)	0.00304(14)	³² S	1967.11(3)	0.00357(18)	0.000337(17)
³¹ P	744.99(5)	0.00101(5)	9.9(5)E-5	³³ S	2127.491(12)	0.00246(10)	2.32(10)E-4
³¹ P	1034.16(4)	0.00206(11)	2.02(11)E-4	³² S	2216.722(17)	0.01210(23)	0.001144(22)
³¹ P	1071.217(23)	0.0249(12)	0.00244(12)	³² S	2313.354(17)	0.00366(13)	0.000346(12)
³¹ P	1149.298(19)	0.00380(19)	0.000372(19)	³⁴ S	2347.695(7)	0.0060(3)	0.00057(3)
³¹ P	1244.64(3)	0.00357(17)	0.000349(17)	³² S	2379.661(14)	0.208(5)	0.0197(5)
³¹ P	1322.72(3)	0.00529(25)	0.000518(24)	³² S	2490.14(3)	0.0125(3)	0.00118(3)
³¹ P	1353.56(5)	0.00126(7)	1.23(7)E-4	³² S	2753.16(3)	0.0277(5)	0.00262(5)
³¹ P	1508.85(3)	0.00318(16)	0.000311(16)	³² S	2867.580(23)	0.00425(15)	0.000402(14)
³¹ P	1676.84(3)	0.00405(20)	0.000396(20)	³² S	2930.67(3)	0.0832(13)	0.00786(12)
³¹ P	1739.14(5)	0.00201(10)	1.97(10)E-4	³⁶ S	3103.36d	2.8(14)E-5	2.7E-6[88%]
³¹ P	1873.52(4)	0.00320(16)	0.000313(16)	³² S	3220.588(17)	0.117(5)	0.0111(5)
³¹ P	1941.05(3)	0.00413(20)	0.000404(20)	³² S	3369.70(4)	0.0271(5)	0.00256(5)
³¹ P	2114.47(3)	0.0115(5)	0.00113(5)	³² S	3397.37(3)	0.00544(15)	0.000514(14)
³¹ P	2151.52(4)	0.0100(5)	0.00098(5)	³² S	3723.54(4)	0.0133(3)	0.00126(3)
³¹ P	2156.90(4)	0.0128(6)	0.00125(6)	³² S	4430.60(4)	0.0262(6)	0.00248(6)
³¹ P	2227.50(5)	0.00248(15)	2.43(15)E-4	³⁴ S	4637.981(14)	0.00734(22)	0.000694(21)
³¹ P	2229.59(3)	0.00080(9)	7.8(9)E-5	³² S	4869.61(3)	0.0650(13)	0.00614(12)
³¹ P	2234.07(6)	0.00123(8)	1.20(8)E-4	³² S	5047.10(3)	0.0163(4)	0.00154(4)
³¹ P	2426.29(3)	0.00265(13)	0.000259(13)	³² S	5420.574(24)	0.308(7)	0.0291(7)
³¹ P	2514.65(4)	0.00156(9)	1.53(9)E-4	³² S	5583.50(3)	0.0086(3)	0.00081(3)
³¹ P	2579.27(6)	0.00082(6)	8.0(6)E-5	³² S	5887.96(3)	0.00373(17)	0.000353(16)
³¹ P	2586.00(4)	0.0089(4)	0.00087(4)	³² S	7799.815(24)	0.0144(5)	0.00136(5)
³¹ P	2657.35(6)	0.00252(14)	2.47(14)E-4	³² S	8640.594(25)	0.0098(7)	0.00093(7)
³¹ P	2740.11(5)	0.00085(5)	8.3(5)E-5	Chlorine (Z=17), At.Wt.=35.453(2), σ_γ^Z=33.1(3)			
³¹ P	2863.01(7)	0.00359(18)	0.000351(18)	³⁵ Cl	292.177(8)	0.0893(10)	0.00763(9)
³¹ P	2885.99(3)	0.0064(3)	0.00063(3)	³⁵ Cl	436.222(4)	0.3090(20)	0.02641(17)
³¹ P	3058.17(4)	0.0110(4)	0.00108(4)	³⁵ Cl	508.866(4)	0.108(17)	0.0092(15)
³¹ P	3185.61(3)	0.00326(12)	0.000319(12)	³⁵ Cl	517.0730(10)	7.58(5)	0.648(4)
³¹ P	3273.98(4)	0.0083(3)	0.00081(3)	³⁵ Cl	632.437(5)	0.1110(16)	0.00949(14)
³¹ P	3365.98(5)	0.00112(5)	1.10(5)E-4	³⁵ Cl	786.3020(10)	3.420(7)	0.2923(6)
³¹ P	3444.06(5)	0.00121(5)	1.18(5)E-4	³⁵ Cl	788.4280(10)	5.42(5)	0.463(4)
³¹ P	3522.59(3)	0.0219(8)	0.00214(8)	³⁵ Cl	936.920(8)	0.1720(13)	0.01470(11)
³¹ P	3548.73(4)	0.00135(6)	1.32(6)E-4	³⁵ Cl	1034.27(22)	0.100(16)	0.0085(14)
³¹ P	3554.31(5)	0.00084(4)	8.2(4)E-5	³⁵ Cl	1131.250(9)	0.626(3)	0.0535(3)
³¹ P	3899.89(3)	0.0294(10)	0.00288(10)	³⁵ Cl	1162.7390(20)	0.76(3)	0.065(3)
³¹ P	3922.87(7)	0.00302(12)	0.000295(12)	³⁵ Cl	1164.8650(10)	8.91(4)	0.762(3)
³¹ P	3926.48(5)	0.00368(14)	0.000360(14)	³⁵ Cl	1170.946(4)	0.154(5)	0.0132(4)
³¹ P	3930.52(5)	0.00108(5)	1.06(5)E-4	³⁵ Cl	1327.405(9)	0.4020(23)	0.03436(20)
³¹ P	3957.10(3)	0.00102(5)	9.98(5)E-5	³⁵ Cl	1372.872(12)	0.105(4)	0.0090(3)
³¹ P	4008.59(5)	0.00122(5)	1.19(5)E-4	³⁵ Cl	1601.072(4)	1.210(7)	0.1034(6)
				³⁵ Cl	1627.04(8)	0.094(5)	0.0080(4)

^A Z	E _γ -keV	σ _γ ^Z (E _γ)-barns	k ₀
³⁵ Cl	1640.099(10)	0.158(17)	0.0135(15)
³⁵ Cl	1648.306(9)	0.174(5)	0.0149(4)
³⁵ Cl	1729.929(9)	0.107(12)	0.0091(10)
³⁵ Cl	1787.82(8)	0.177(6)	0.0151(5)
³⁵ Cl	1828.49(4)	0.111(5)	0.0095(4)
³⁵ Cl	1936.97(5)	0.153(9)	0.0131(8)
³⁵ Cl	1951.1400(20)	6.33(4)	0.541(3)
³⁵ Cl	1959.346(4)	4.10(3)	0.350(3)
³⁵ Cl	1975.22(7)	0.214(22)	0.0183(19)
³⁷ Cl	1980.94(7)	0.045(4)	0.0038(3)
³⁵ Cl	2022.091(7)	0.161(6)	0.0138(5)
³⁵ Cl	2034.63(3)	0.239(5)	0.0204(4)
³⁵ Cl	2041.40(6)	0.121(5)	0.0103(4)
³⁵ Cl	2075.440(13)	0.252(7)	0.0215(6)
³⁵ Cl	2104(5)	0.105(7)	0.0090(6)
³⁵ Cl	2156.19(4)	0.205(7)	0.0175(6)
³⁷ Cl	2166.90(20)d	0.0568(15)	0.00486[40%]
³⁵ Cl	2179.51(4)	0.12(5)	0.010(4)
³⁵ Cl	2200.10(4)	0.123(5)	0.0105(4)
³⁵ Cl	2289.78(16)	0.102(14)	0.0087(12)
³⁵ Cl	2311.38(4)	0.35(10)	0.030(9)
³⁵ Cl	2468.1830(20)	0.097(8)	0.0083(7)
³⁵ Cl	2469.97(3)	0.24(3)	0.021(3)
³⁵ Cl	2478(5)	0.101(20)	0.0086(17)
³⁵ Cl	2489.74(9)	0.141(6)	0.0121(5)
³⁵ Cl	2492.223(9)	0.11(4)	0.009(3)
³⁵ Cl	2529.2(11)	0.121(13)	0.0103(11)
³⁵ Cl	2537.25(7)	0.135(14)	0.0115(12)
³⁵ Cl	2549.74(7)	0.090(15)	0.0077(13)
³⁵ Cl	2622.86(5)	0.178(6)	0.0152(5)
³⁵ Cl	2676.31(3)	0.533(4)	0.0456(3)
³⁵ Cl	2797.90(4)	0.095(10)	0.0081(9)
³⁵ Cl	2800.96(12)	0.183(7)	0.0156(6)
³⁵ Cl	2808.86(7)	0.10(5)	0.009(4)
³⁵ Cl	2810.988(9)	0.144(7)	0.0123(6)
³⁵ Cl	2845.50(3)	0.349(3)	0.0298(3)
³⁵ Cl	2863.819(12)	1.820(10)	0.1556(9)
³⁵ Cl	2866.9(5)	0.192(12)	0.0164(10)
³⁵ Cl	2876.49(5)	0.164(7)	0.0140(6)
³⁵ Cl	2896.212(8)	0.146(6)	0.0125(5)
³⁵ Cl	2975.21(7)	0.377(4)	0.0322(3)
³⁵ Cl	2994.548(15)	0.279(8)	0.0238(7)
³⁵ Cl	3001.07(5)	0.216(7)	0.0185(6)
³⁵ Cl	3015.97(4)	0.328(3)	0.0280(3)
³⁵ Cl	3061.82(4)	1.130(7)	0.0966(6)
³⁵ Cl	3116.04(5)	0.297(3)	0.0254(3)
³⁵ Cl	3332.87(8)	0.241(7)	0.0206(6)
³⁵ Cl	3374.7(11)	0.179(7)	0.0153(6)
³⁵ Cl	3428.83(5)	0.271(3)	0.0232(3)
³⁵ Cl	3500.35(9)	0.100(6)	0.0085(5)
³⁵ Cl	3561.37(7)	0.21(4)	0.018(3)
³⁵ Cl	3566.32(4)	0.093(24)	0.0079(21)
³⁵ Cl	3589.16(13)	0.18(5)	0.015(4)
³⁵ Cl	3599.350(9)	0.164(6)	0.0140(5)
³⁵ Cl	3604.14(17)	0.119(6)	0.0102(5)
³⁵ Cl	3634.75(3)	0.098(6)	0.0084(5)
³⁵ Cl	3749.91(10)	0.096(5)	0.0082(4)
³⁵ Cl	3821.33(16)	0.320(10)	0.0274(9)
³⁵ Cl	3825.22(13)	0.250(9)	0.0214(8)
³⁵ Cl	3827.06(12)	0.238(17)	0.0203(15)
³⁵ Cl	3962.67(4)	0.118(8)	0.0101(7)
³⁵ Cl	3980.98(8)	0.331(7)	0.0283(6)
³⁵ Cl	4054.25(5)	0.194(8)	0.0166(7)
³⁵ Cl	4082.67(7)	0.263(5)	0.0225(4)
³⁵ Cl	4138.39(9)	0.113(17)	0.0097(15)
³⁵ Cl	4138.73(4)	0.095(10)	0.0081(9)
³⁵ Cl	4298.33(4)	0.122(10)	0.0104(9)
³⁵ Cl	4440.39(4)	0.377(4)	0.0322(3)

^A Z	E _γ -keV	σ _γ ^Z (E _γ)-barns	k ₀
³⁵ Cl	4524.87(4)	0.148(7)	0.0127(6)
³⁵ Cl	4547.5(5)	0.146(8)	0.0125(7)
³⁵ Cl	4616.45(9)	0.210(10)	0.0180(9)
³⁵ Cl	4728.94(4)	0.223(9)	0.0191(8)
³⁵ Cl	4944.36(4)	0.379(8)	0.0324(7)
³⁵ Cl	4945.25(3)	0.194(18)	0.0166(15)
³⁵ Cl	4979.759(20)	1.230(10)	0.1051(9)
³⁵ Cl	4989.66(12)	0.10(6)	0.009(5)
³⁵ Cl	5017.74(7)	0.161(8)	0.0138(7)
³⁵ Cl	5246.958(21)	0.195(10)	0.0167(9)
³⁵ Cl	5517.25(4)	0.560(5)	0.0479(4)
³⁵ Cl	5584.525(23)	0.158(11)	0.0135(9)
³⁵ Cl	5603.76(9)	0.11(3)	0.009(3)
³⁵ Cl	5702.58(6)	0.127(10)	0.0109(9)
³⁵ Cl	5715.244(21)	1.820(16)	0.1556(14)
³⁵ Cl	5733.56(3)	0.161(11)	0.0138(9)
³⁵ Cl	5902.74(3)	0.372(4)	0.0318(3)
³⁵ Cl	6086.804(20)	0.295(15)	0.0252(13)
³⁵ Cl	6110.842(18)	6.59(6)	0.563(5)
³⁵ Cl	6267.63(4)	0.13(4)	0.011(3)
³⁵ Cl	6619.615(19)	2.530(23)	0.2163(20)
³⁵ Cl	6627.821(18)	1.470(16)	0.1257(14)
³⁵ Cl	6977.836(19)	0.741(10)	0.0633(9)
³⁵ Cl	7413.968(18)	3.29(5)	0.281(4)
³⁵ Cl	7790.330(18)	2.66(3)	0.227(3)
³⁵ Cl	8578.575(18)	0.883(13)	0.0755(11)
Argon (Z=18), At. Wt.=39.948(1), σ_γ^Z=0.675(10)			
⁴⁰ Ar	167.30(20)	0.53(5)	0.040(4)
⁴⁰ Ar	348.7(3)	0.044(9)	0.0033(7)
⁴⁰ Ar	516.0(3)	0.167(17)	0.0127(13)
⁴⁰ Ar	518.7	0.0060(20)	0.00046(15)
⁴⁰ Ar	837.7(3)	0.063(7)	0.0048(5)
⁴⁰ Ar	867.3(6)	0.0070(20)	0.00053(15)
⁴⁰ Ar	1044.3(4)	0.040(8)	0.0030(6)
⁴⁰ Ar	1186.8(3)	0.34(3)	0.0258(23)
⁴⁰ Ar	1354.0(4)	0.015(4)	0.0011(3)
³⁶ Ar	1409.7(10)	0.0060(12)	0.00046(9)
⁴⁰ Ar	1828.8(12)	0.0070(20)	0.00053(15)
⁴⁰ Ar	1881.5(10)	0.009(3)	0.00068(23)
⁴⁰ Ar	2130.8(8)	0.029(5)	0.0022(4)
⁴⁰ Ar	2432.5(8)	0.0055(14)	0.00042(11)
³⁶ Ar	2490.8(8)	0.0088(22)	0.00067(17)
⁴⁰ Ar	2566.1(8)	0.018(4)	0.0014(3)
⁴⁰ Ar	2614.4(8)	0.019(4)	0.0014(3)
⁴⁰ Ar	2771.9(8)	0.057(9)	0.0043(7)
⁴⁰ Ar	2781.8(15)	0.011(3)	0.00083(23)
⁴⁰ Ar	2810.6(8)	0.039(8)	0.0030(6)
⁴⁰ Ar	2842.6(10)	0.0058(14)	0.00044(11)
⁴⁰ Ar	3089.5(10)	0.0070(20)	0.00053(15)
⁴⁰ Ar	3150.3(10)	0.026(5)	0.0020(4)
⁴⁰ Ar	3365.6(10)	0.028(6)	0.0021(5)
⁴⁰ Ar	3452.0(10)	0.013(3)	0.00099(23)
⁴⁰ Ar	3700.6(8)	0.065(7)	0.0049(5)
⁴⁰ Ar	4745.3(8)	0.36(4)	0.027(3)
⁴⁰ Ar	5582.4(8)	0.077(8)	0.0058(6)
³⁶ Ar	6298.9(10)	0.0076(19)	0.00058(14)
Potassium (Z=19), At. Wt.=39.0983(1), σ_γ^Z=2.06(19)			
³⁹ K	29.8300(10)	1.380(20)	0.1070(16)
⁴¹ K	106.836(7)	0.0320(6)	0.00248(5)
³⁹ K	522.319(7)	0.0347(7)	0.00269(5)
³⁹ K	646.222(5)	0.0451(8)	0.00350(6)
⁴¹ K	681.937(8)	0.0149(5)	0.00115(4)
³⁹ K	770.3050(20)	0.903(12)	0.0700(9)
³⁹ K	843.468(10)	0.0197(5)	0.00153(4)
³⁹ K	891.385(13)	0.019(4)	0.0015(3)
³⁹ K	1086.707(16)	0.0222(7)	0.00172(5)
³⁹ K	1158.887(10)	0.1600(25)	0.01240(19)
³⁹ K	1247.193(11)	0.0784(13)	0.00608(10)

^A Z	E _γ -keV	σ _γ ^Z (E _γ)-barns	k ₀
⁴⁰ K	1293.589(5)	0.0041(8)	0.00032(6)
³⁹ K	1303.515(19)	0.0550(12)	0.00426(9)
³⁹ K	1373.227(18)	0.0251(7)	0.00195(5)
⁴⁰K	1460.822(6)	3.24(5) s⁻¹g⁻¹	Abundant
³⁹ K	1480.024(24)	0.0353(9)	0.00274(7)
³⁹ K	1489.676(10)	0.0277(8)	0.00215(6)
⁴¹ K	1524.6(3)d	0.02000(4)	0.001550[2.8%]
³⁹ K	1613.756(10)	0.1190(20)	0.00922(16)
³⁹ K	1618.973(10)	0.1300(21)	0.01008(16)
³⁹ K	1704.656(23)	0.0244(8)	0.00189(6)
³⁹ K	1795.438(24)	0.0292(8)	0.00226(6)
³⁹ K	1825.815(19)	0.0147(7)	0.00114(5)
³⁹ K	1929.169(10)	0.0397(9)	0.00308(7)
³⁹ K	1956.515(24)	0.0406(11)	0.00315(9)
³⁹ K	2007.69(3)	0.0513(12)	0.00398(9)
³⁹ K	2017.472(11)	0.0540(12)	0.00419(9)
³⁹ K	2039.924(18)	0.0519(13)	0.00402(10)
³⁹ K	2047.301(11)	0.0537(13)	0.00416(10)
³⁹ K	2069.752(18)	0.0363(10)	0.00281(8)
³⁹ K	2073.793(19)	0.1370(24)	0.01062(19)
³⁹ K	2153.86(3)	0.0158(7)	0.00122(5)
³⁹ K	2206.22(4)	0.0166(12)	0.00129(9)
³⁹ K	2206.26(3)	0.0157(17)	0.00122(13)
³⁹ K	2230.54(3)	0.0202(10)	0.00157(8)
³⁹ K	2290.420(19)	0.0582(13)	0.00451(10)
³⁹ K	2346.22(4)	0.0138(7)	0.00107(5)
³⁹ K	2367.30(3)	0.0157(7)	0.00122(5)
³⁹ K	2389.245(10)	0.0301(10)	0.00233(8)
³⁹ K	2545.99(3)	0.0536(12)	0.00415(9)
³⁹ K	2609.97(3)	0.0213(7)	0.00165(5)
³⁹ K	2614.18(3)	0.0165(6)	0.00128(5)
³⁹ K	2638.866(24)	0.0144(6)	0.00112(5)
³⁹ K	2726.780(24)	0.0225(9)	0.00174(7)
³⁹ K	2756.678(17)	0.0404(22)	0.00313(17)
³⁹ K	2799.04(3)	0.0145(7)	0.00112(5)
³⁹ K	2806.42(3)	0.0256(9)	0.00198(7)
³⁹ K	2938.17(3)	0.0140(9)	0.00109(7)
³⁹ K	3055.30(3)	0.0464(12)	0.00360(9)
³⁹ K	3262.28(4)	0.0376(11)	0.00291(9)
³⁹ K	3304.17(4)	0.0146(7)	0.00113(5)
³⁹ K	3338.05(6)	0.036(17)	0.0028(13)
³⁹ K	3348.72(3)	0.0172(8)	0.00133(6)
³⁹ K	3403.58(3)	0.0167(8)	0.00129(6)
³⁹ K	3453.38(3)	0.0247(14)	0.00191(11)
³⁹ K	3518.77(6)	0.0186(9)	0.00144(7)
³⁹ K	3526.97(3)	0.0170(9)	0.00132(7)
³⁹ K	3545.71(3)	0.0746(18)	0.00578(14)
³⁹ K	3650.37(3)	0.0355(13)	0.00275(10)
³⁹ K	3688.54(3)	0.0276(11)	0.00214(9)
³⁹ K	3694.91(4)	0.0231(10)	0.00179(8)
³⁹ K	3736.81(3)	0.0193(6)	0.00150(5)
³⁹ K	3778.97(4)	0.0143(7)	0.00111(5)
³⁹ K	3911.43(5)	0.0168(9)	0.00130(7)
³⁹ K	3930.63(4)	0.0275(11)	0.00213(9)
³⁹ K	3943.78(3)	0.0205(11)	0.00159(9)
³⁹ K	3959.10(3)	0.0252(10)	0.00195(8)
³⁹ K	3977.89(3)	0.0219(10)	0.00170(8)
³⁹ K	4001.80(3)	0.0263(11)	0.00204(9)
³⁹ K	4060.91(3)	0.0244(10)	0.00189(8)
³⁹ K	4135.586(23)	0.0563(17)	0.00436(13)
³⁹ K	4200.04(3)	0.0398(14)	0.00308(11)
³⁹ K	4360.201(25)	0.0776(21)	0.00601(16)
³⁹ K	4384.88(3)	0.0247(11)	0.00191(9)
³⁹ K	4507.03(3)	0.0159(9)	0.00123(7)
³⁹ K	4670.76(3)	0.0138(9)	0.00107(7)
³⁹ K	4991.34(3)	0.0432(14)	0.00335(11)
³⁹ K	5012.48(3)	0.0226(11)	0.00175(9)
³⁹ K	5042.507(25)	0.0351(15)	0.00272(12)

^A Z	E _γ -keV	σ _γ ^Z (E _γ)-barns	k ₀
³⁹ K	5068.870(21)	0.0224(12)	0.00174(9)
³⁹ K	5173.196(21)	0.048(3)	0.00372(23)
³⁹K	5380.018(16)	0.146(4)	0.0113(3)
³⁹ K	5508.660(21)	0.066(4)	0.0051(3)
³⁹ K	5695.442(20)	0.114(3)	0.00884(23)
³⁹ K	5729.308(22)	0.0437(18)	0.00339(14)
³⁹ K	5751.758(17)	0.108(3)	0.00837(23)
³⁹ K	6998.758(14)	0.0447(20)	0.00346(16)
³⁹ K	7768.919(14)	0.117(7)	0.0091(5)
Calcium (Z=20), At. Wt.=40.078(4), σ_γ^Z=0.431(19)			
⁴⁴ Ca	174.12(7)	0.0168(4)	0.00127(3)
⁴⁰Ca	519.66(5)	0.0503(13)	0.00380(10)
⁴⁰ Ca	660.00(5)	0.00487(18)	0.000368(14)
⁴⁰ Ca	727.17(5)	0.0117(4)	0.00088(3)
⁴³ Ca	1126.12(10)	0.00471(23)	0.000356(17)
⁴⁰ Ca	1150.95(5)	0.0052(3)	0.000393(23)
⁴³ Ca	1156.94(12)	0.0088(4)	0.00067(3)
⁴⁴ Ca	1260.62(6)	0.00394(24)	0.000298(18)
⁴⁰ Ca	1389.82(5)	0.0106(4)	0.00080(3)
⁴⁰ Ca	1481.67(5)	0.0051(3)	0.000386(23)
⁴⁰ Ca	1670.60(6)	0.0069(3)	0.000522(23)
⁴⁴ Ca	1725.71(7)	0.0090(4)	0.00068(3)
⁴⁰Ca	1942.67(3)	0.352(7)	0.0266(5)
⁴⁰Ca	2001.31(3)	0.0659(15)	0.00498(11)
⁴⁰Ca	2009.84(3)	0.0409(10)	0.00309(8)
⁴⁶ Ca	2013.57(20)	2.90E-05	2.20E-06
⁴⁰ Ca	2290.43(5)	0.0077(4)	0.00058(3)
⁴⁰ Ca	2605.34(6)	0.0061(4)	0.00046(3)
⁴⁰ Ca	2660.37(7)	0.0074(4)	0.00056(3)
⁴⁰ Ca	2767.92(7)	0.0070(15)	0.00053(11)
⁴⁰ Ca	2810.06(5)	0.0167(5)	0.00126(4)
⁴⁸ Ca	3084.40(10)d	0.00190(21)	1.44E-4[79%]
⁴⁰ Ca	3584.77(7)	0.0100(5)	0.00076(4)
⁴⁰ Ca	3609.80(6)	0.0283(9)	0.00214(7)
⁴⁰ Ca	3759.48(7)	0.0117(5)	0.00088(4)
⁴⁰Ca	4418.52(5)	0.0708(18)	0.00535(14)
⁴⁰ Ca	4516.54(17)	0.0049(3)	0.000371(23)
⁴⁰ Ca	4749.21(7)	0.0134(7)	0.00101(5)
⁴⁰ Ca	4962.79(7)	0.0067(4)	0.00051(3)
⁴⁸ Ca	5146.19(21)	0.00147(20)	1.11(15)E-4
⁴⁴ Ca	5514.55(14)	0.0104(8)	0.00079(6)
⁴⁰ Ca	5692.53(6)	0.0067(5)	0.00051(4)
⁴² Ca	5885.87(16)	0.0024(4)	1.8(3)E-4
⁴⁰ Ca	5900.02(6)	0.0258(12)	0.00195(9)
⁴⁰Ca	6419.59(5)	0.176(5)	0.0133(4)
Scandium (Z=21), At. Wt.=44.955910(8), σ_γ^Z=27.20(20)			
⁴⁵Sc	52.0110(10)	0.87(3)	0.0586(20)
⁴⁵Sc	142.528(8)d	4.88(7)	0.329[99%]
⁴⁵Sc	147.011(10)	6.08(9)	0.410(6)
⁴⁵Sc	216.44(4)	2.49(4)	0.168(3)
⁴⁵Sc	227.773(12)	7.13(11)	0.481(7)
⁴⁵Sc	228.716(12)	3.31(5)	0.223(3)
⁴⁵ Sc	280.726(12)	0.248(7)	0.0167(5)
⁴⁵Sc	295.243(10)	3.97(11)	0.268(7)
⁴⁵ Sc	399.691(19)	0.202(7)	0.0136(5)
⁴⁵ Sc	402.87(5)	0.107(6)	0.0072(4)
⁴⁵ Sc	442.254(13)	0.096(6)	0.0065(4)
⁴⁵ Sc	478.14(13)	0.073(10)	0.0049(7)
⁴⁵ Sc	486.026(21)	0.593(14)	0.0400(9)
⁴⁵Sc	539.437(20)	0.738(19)	0.0497(13)
⁴⁵ Sc	547.15(4)	0.373(12)	0.0251(8)
⁴⁵Sc	554.44(4)	1.82(4)	0.123(3)
⁴⁵Sc	584.785(13)	1.77(3)	0.1193(20)
⁴⁵Sc	627.462(18)	2.23(5)	0.150(3)
⁴⁵ Sc	643.037(25)	0.259(9)	0.0175(6)
⁴⁵ Sc	685.71(3)	0.149(9)	0.0100(6)
⁴⁵ Sc	711.21(6)	0.104(8)	0.0070(5)

A	Z	E_{γ} -keV	$\sigma_{\gamma}^Z(E_{\gamma})$ -barns	k_0	A	Z	E_{γ} -keV	$\sigma_{\gamma}^Z(E_{\gamma})$ -barns	k_0
⁴⁵ Sc		721.841(17)	0.487(15)	0.0328(10)	⁴⁵ Sc		3080.8(5)	0.087(12)	0.0059(8)
⁴⁵ Sc		773.851(17)	0.572(13)	0.0386(9)	⁴⁵ Sc		3265.48(7)	0.146(14)	0.0098(9)
⁴⁵ Sc		807.754(20)	0.523(13)	0.0353(9)	⁴⁵ Sc		3281.87(8)	0.08(4)	0.005(3)
⁴⁵ Sc		835.16(4)	0.265(8)	0.0179(5)	⁴⁵ Sc		3309.70(9)	0.08(3)	0.0054(20)
⁴⁵ Sc		843.494(23)	0.138(6)	0.0093(4)	⁴⁵ Sc		3351.10(12)	0.121(14)	0.0082(9)
⁴⁵ Sc		860.707(19)	0.396(13)	0.0267(9)	⁴⁵ Sc		3458.45(19)	0.156(15)	0.0105(10)
⁴⁵ Sc		899.27(5)	0.133(9)	0.0090(6)	⁴⁵ Sc		3596.86(10)	0.077(14)	0.0052(9)
⁴⁵ Sc		941.95(5)	0.107(24)	0.0072(16)	⁴⁵ Sc		3623.19(10)	0.13(6)	0.009(4)
⁴⁵ Sc		1015.22(3)	0.256(12)	0.0173(8)	⁴⁵ Sc		3799.13(8)	0.125(13)	0.0084(9)
⁴⁵ Sc		1057.89(3)	0.322(14)	0.0217(9)	⁴⁵ Sc		3878.05(12)	0.088(11)	0.0059(7)
⁴⁵ Sc		1082.52(4)	0.160(11)	0.0108(7)	⁴⁵ Sc		3999.48(12)	0.086(17)	0.0058(11)
⁴⁵ Sc		1123.17(5)	0.380(14)	0.0256(9)	⁴⁵ Sc		4006.31(10)	0.091(17)	0.0061(11)
⁴⁵ Sc		1134.43(8)	0.132(9)	0.0089(6)	⁴⁵ Sc		4021.46(9)	0.092(17)	0.0062(11)
⁴⁵ Sc		1166.45(6)	0.386(14)	0.0260(9)	⁴⁵ Sc		4059.52(8)	0.18(3)	0.0121(20)
⁴⁵ Sc		1227.77(4)	0.332(13)	0.0224(9)	⁴⁵ Sc		4065.97(9)	0.079(19)	0.0053(13)
⁴⁵ Sc		1251.68(6)	0.101(9)	0.0068(6)	⁴⁵ Sc		4109.60(9)	0.073(10)	0.0049(7)
⁴⁵ Sc		1251.69(6)	0.129(23)	0.0087(16)	⁴⁵ Sc		4173.36(17)	0.11(3)	0.0074(20)
⁴⁵ Sc		1268.87(6)	0.10(3)	0.0067(20)	⁴⁵ Sc		4231.81(16)	0.073(9)	0.0049(6)
⁴⁵ Sc		1270.49(3)	0.269(13)	0.0181(9)	⁴⁵ Sc		4237.72(10)	0.096(17)	0.0065(11)
⁴⁵ Sc		1285.34(4)	0.373(19)	0.0251(13)	⁴⁵ Sc		4293.30(21)	0.073(11)	0.0049(7)
⁴⁵ Sc		1321.18(4)	0.206(23)	0.0139(16)	⁴⁵ Sc		4377.46(8)	0.127(15)	0.0086(10)
⁴⁵ Sc		1321.96(4)	0.139(9)	0.0094(6)	⁴⁵ Sc		4465.89(13)	0.106(13)	0.0071(9)
⁴⁵ Sc		1335.05(3)	0.640(22)	0.0431(15)	⁴⁵ Sc		4498.85(11)	0.149(15)	0.0100(10)
⁴⁵ Sc		1510.13(6)	0.13(4)	0.009(3)	⁴⁵ Sc		4617.93(9)	0.089(15)	0.0060(10)
⁴⁵ Sc		1575.27(3)	0.317(13)	0.0214(9)	⁴⁵ Sc		4679.04(18)	0.112(14)	0.0075(9)
⁴⁵ Sc		1592.71(17)	0.11(3)	0.0074(20)	⁴⁵ Sc		4720.86(11)	0.171(16)	0.0115(11)
⁴⁵ Sc		1618.36(6)	0.362(19)	0.0244(13)	⁴⁵ Sc		4823.18(9)	0.078(11)	0.0053(7)
⁴⁵ Sc		1658.21(7)	0.107(12)	0.0072(8)	⁴⁵ Sc		4883.71(13)	0.128(13)	0.0086(9)
⁴⁵ Sc		1693.30(4)	0.465(19)	0.0313(13)	⁴⁵ Sc		4891.84(10)	0.094(12)	0.0063(8)
⁴⁵ Sc		1707.94(5)	0.077(10)	0.0052(7)	⁴⁵ Sc		4919.38(11)	0.092(13)	0.0062(9)
⁴⁵ Sc		1753.85(4)	0.170(12)	0.0115(8)	⁴⁵ Sc		4974.76(9)	0.498(24)	0.0336(16)
⁴⁵ Sc		1763.12(10)	0.077(10)	0.0052(7)	⁴⁵ Sc		4993.58(10)	0.177(15)	0.0119(10)
⁴⁵ Sc		1777.43(11)	0.125(12)	0.0084(8)	⁴⁵ Sc		5085.09(10)	0.103(14)	0.0069(9)
⁴⁵ Sc		1803.69(12)	0.075(9)	0.0051(6)	⁴⁵ Sc		5128.48(12)	0.093(15)	0.0063(10)
⁴⁵ Sc		1814.92(4)	0.271(13)	0.0183(9)	⁴⁵ Sc		5163.42(10)	0.149(20)	0.0100(13)
⁴⁵ Sc		1829.68(6)	0.152(10)	0.0102(7)	⁴⁵ Sc		5210.11(12)	0.085(15)	0.0057(10)
⁴⁵ Sc		1857.59(4)	0.393(17)	0.0265(11)	⁴⁵ Sc		5267.04(7)	0.38(3)	0.0256(20)
⁴⁵ Sc		1870.06(5)	0.206(13)	0.0139(9)	⁴⁵ Sc		5286.20(8)	0.123(15)	0.0083(10)
⁴⁵ Sc		1885.97(7)	0.090(11)	0.0061(7)	⁴⁵ Sc		5335.89(8)	0.20(3)	0.0135(20)
⁴⁵ Sc		1900.85(4)	0.274(11)	0.0185(7)	⁴⁵ Sc		5346.19(10)	0.094(19)	0.0063(13)
⁴⁵ Sc		1913.59(6)	0.077(7)	0.0052(5)	⁴⁵ Sc		5445.75(8)	0.170(19)	0.0115(13)
⁴⁵ Sc		1966.59(8)	0.080(8)	0.0054(5)	⁴⁵ Sc		5481.62(9)	0.142(19)	0.0096(13)
⁴⁵ Sc		1975.36(6)	0.078(8)	0.0053(5)	⁴⁵ Sc		5555.57(10)	0.079(14)	0.0053(9)
⁴⁵ Sc		2005.24(4)	0.351(11)	0.0237(7)	⁴⁵ Sc		5583.82(10)	0.118(16)	0.0080(11)
⁴⁵ Sc		2058.84(9)	0.097(10)	0.0065(7)	⁴⁵ Sc		5624.09(8)	0.198(20)	0.0133(13)
⁴⁵ Sc		2106.25(8)	0.143(11)	0.0096(7)	⁴⁵ Sc		5665.71(9)	0.145(19)	0.0098(13)
⁴⁵ Sc		2110.20(10)	0.117(11)	0.0079(7)	⁴⁵ Sc		5678.79(13)	0.077(16)	0.0052(11)
⁴⁵ Sc		2114.14(6)	0.210(13)	0.0142(9)	⁴⁵ Sc		5743.38(7)	0.184(17)	0.0124(11)
⁴⁵ Sc		2129.69(4)	0.101(10)	0.0068(7)	⁴⁵ Sc		5781.24(15)	0.072(15)	0.0049(10)
⁴⁵ Sc		2203.45(13)	0.102(10)	0.0069(7)	⁴⁵ Sc		5896.94(8)	0.42(3)	0.0283(20)
⁴⁵ Sc		2243.06(6)	0.110(11)	0.0074(7)	⁴⁵ Sc		5904.31(12)	0.084(17)	0.0057(11)
⁴⁵ Sc		2351.59(15)	0.074(9)	0.0050(6)	⁴⁵ Sc		5977.32(10)	0.075(12)	0.0051(8)
⁴⁵ Sc		2362.36(9)	0.085(9)	0.0057(6)	⁴⁵ Sc		6046.15(9)	0.144(19)	0.0097(13)
⁴⁵ Sc		2373.41(17)	0.086(9)	0.0058(6)	⁴⁵ Sc		6055.05(5)	0.265(24)	0.0179(16)
⁴⁵ Sc		2404.82(7)	0.127(10)	0.0086(7)	⁴⁵ Sc		6097.64(10)	0.082(12)	0.0055(8)
⁴⁵ Sc		2410.40(4)	0.087(9)	0.0059(6)	⁴⁵ Sc		6170.22(4)	0.47(5)	0.032(3)
⁴⁵ Sc		2477.42(6)	0.145(14)	0.0098(9)	⁴⁵ Sc		6201.40(13)	0.073(8)	0.0049(5)
⁴⁵ Sc		2502.20(10)	0.082(12)	0.0055(8)	⁴⁵ Sc		6300.79(8)	0.183(25)	0.0123(17)
⁴⁵ Sc		2635.55(8)	0.301(15)	0.0203(10)	⁴⁵ Sc		6309.27(11)	0.075(8)	0.0051(5)
⁴⁵ Sc		2667.03(11)	0.127(14)	0.0086(9)	⁴⁵ Sc		6317.86(4)	0.58(4)	0.039(3)
⁴⁵ Sc		2693.90(9)	0.107(14)	0.0072(9)	⁴⁵ Sc		6329.00(13)	0.185(22)	0.0125(15)
⁴⁵ Sc		2697.12(8)	0.084(14)	0.0057(9)	⁴⁵ Sc		6349.80(4)	0.53(4)	0.036(3)
⁴⁵ Sc		2721.37(16)	0.096(8)	0.0065(5)	⁴⁵ Sc		6364.43(9)	0.119(20)	0.0080(13)
⁴⁵ Sc		2797.52(10)	0.105(11)	0.0071(7)	⁴⁵ Sc		6457.68(7)	0.099(14)	0.0067(9)
⁴⁵ Sc		2991.04(11)	0.092(14)	0.0062(9)	⁴⁵ Sc		6468.55(13)	0.122(21)	0.0082(14)
⁴⁵ Sc		2995.96(11)	0.079(13)	0.0053(9)	⁴⁵ Sc		6507.47(10)	0.107(12)	0.0072(8)
⁴⁵ Sc		3011.73(8)	0.278(19)	0.0187(13)	⁴⁵ Sc		6557.06(6)	0.384(24)	0.0259(16)
⁴⁵ Sc		3049.06(7)	0.106(12)	0.0071(8)	⁴⁵ Sc		6640.96(6)	0.150(23)	0.0101(16)

^A Z	E _γ -keV	σ _γ ^Z (E _γ)-barns	k ₀	^A Z	E _γ -keV	σ _γ ^Z (E _γ)-barns	k ₀
⁴⁵ Sc	6646.04(6)	0.113(12)	0.0076(8)	⁵¹ V	1272.67(3)	0.0291(21)	0.00173(12)
⁴⁵ Sc	6716.79(4)	0.312(22)	0.0210(15)	⁵¹ V	1307.279(17)	0.0410(19)	0.00244(11)
⁴⁵ Sc	6839.09(4)	0.95(4)	0.064(3)	⁵¹ V	1322.664(22)	0.047(10)	0.0028(6)
⁴⁵ Sc	6840.34(4)	0.76(11)	0.051(7)	⁵¹ V	1322.98(3)	0.0260(21)	0.00155(12)
⁴⁵ Sc	6874.18(7)	0.125(14)	0.0084(9)	⁵¹ V	1333.52(3)	0.0345(21)	0.00205(12)
⁴⁵ Sc	7117.46(3)	0.39(3)	0.0263(20)	⁵¹ V	1358.498(19)	0.151(5)	0.0090(3)
⁴⁵ Sc	7233.39(5)	0.110(14)	0.0074(9)	⁵¹ V	1401.641(16)	0.070(4)	0.00416(24)
⁴⁵ Sc	7489.58(3)	0.077(12)	0.0052(8)	⁵¹ V	1418.793(15)	0.068(4)	0.00405(24)
⁴⁵ Sc	7635.84(3)	0.40(3)	0.0270(20)	⁵¹ V	1434.10(3)d	4.81(10)	0.286[91%]
⁴⁵ Sc	7924.84(4)	0.095(18)	0.0064(12)	⁵¹ V	1558.843(18)	0.323(8)	0.0192(5)
⁴⁵ Sc	8132.507(25)	0.48(3)	0.0324(20)	⁵⁰ V	1609.220(20)	0.0359(17)	0.00214(10)
⁴⁵ Sc	8175.176(21)	1.80(6)	0.121(4)	⁵¹ V	1611.758(25)	0.0236(15)	0.00140(9)
⁴⁵ Sc	8315.73(4)	0.41(3)	0.0276(20)	⁵¹ V	1622.296(25)	0.0206(7)	0.00123(4)
⁴⁵ Sc	8470.363(20)	0.120(14)	0.0081(9)	⁵¹ V	1634.068(22)	0.0359(19)	0.00214(11)
⁴⁵ Sc	8532.122(20)	0.89(4)	0.060(3)	⁵¹ V	1635.382(24)	0.020(4)	0.00119(24)
⁴⁵ Sc	8759.850(20)	0.168(16)	0.0113(11)	⁵¹ V	1664.192(17)	0.0519(24)	0.00309(14)
Titanium (Z=22), At.Wt.=47.867(1), σ_γ^Z=6.08(19)				⁵¹ V	1732.563(20)	0.0161(16)	0.00096(10)
⁴⁸ Ti	137.504(8)	0.0542(9)	0.00343(6)	⁵¹ V	1775.431(21)	0.027(6)	0.0016(4)
⁴⁶ Ti	159.376(14)	0.0090(8)	0.00057(5)	⁵¹ V	1777.961(19)	0.169(13)	0.0101(8)
⁵⁰ Ti	320.076(6)d	0.00860(9)	0.000544[86%]	⁵¹ V	1952.964(14)	0.0677(25)	0.00403(15)
⁴⁸ Ti	341.706(5)	1.840(21)	0.1165(13)	⁵¹ V	2020.749(18)	0.0214(17)	0.00127(10)
⁴⁷ Ti	983.517(4)	0.1140(16)	0.00722(10)	⁵¹ V	2083.652(14)	0.0339(19)	0.00202(11)
⁴⁹ Ti	1121.130(6)	0.0630(14)	0.00399(9)	⁵¹ V	2100.804(14)	0.0239(15)	0.00142(9)
⁵⁰ Ti	1166.6(4)	3.90E-03	2.50E-04	⁵¹ V	2145.826(18)	0.140(4)	0.00833(24)
⁴⁸ Ti	1381.745(5)	5.18(12)	0.328(8)	⁵¹ V	2168.589(18)	0.0166(12)	0.00099(7)
⁴⁸ Ti	1498.663(7)	0.297(5)	0.0188(3)	⁵¹ V	2410.436(21)	0.0253(17)	0.00151(10)
⁴⁹ Ti	1553.786(6)	0.0967(22)	0.00612(14)	⁵¹ V	2422.18(3)	0.112(24)	0.0067(14)
⁴⁸ Ti	1585.941(5)	0.624(8)	0.0395(5)	⁵¹ V	2841.64(3)	0.0333(19)	0.00198(11)
⁴⁸ Ti	1589.282(10)	0.0524(16)	0.00332(10)	⁵¹ V	3032.60(9)	0.0249(20)	0.00148(12)
⁴⁸ Ti	1761.974(7)	0.311(4)	0.01969(25)	⁵¹ V	3502.64(4)	0.0306(18)	0.00182(11)
⁴⁸ Ti	1793.476(8)	0.1530(24)	0.00969(15)	⁵¹ V	3534.07(3)	0.0243(21)	0.00145(12)
⁴⁸ Ti	2836.1(7)	0.055(12)	0.0035(8)	⁵¹ V	3577.98(3)	0.0271(20)	0.00161(12)
⁴⁸ Ti	2836.9(7)	0.055(12)	0.0035(8)	⁵¹ V	3715.86(3)	0.0256(21)	0.00152(12)
⁴⁸ Ti	2943.07(3)	0.0614(18)	0.00389(11)	⁵¹ V	4116.821(23)	0.094(4)	0.00559(24)
⁴⁸ Ti	3026.704(20)	0.145(3)	0.00918(19)	⁵¹ V	4452.20(3)	0.050(10)	0.0030(6)
⁴⁸ Ti	3027.0(7)	0.13(3)	0.0082(19)	⁵¹ V	4486.46(3)	0.0187(20)	0.00111(12)
⁴⁸ Ti	3475.58(3)	0.1020(25)	0.00646(16)	⁵¹ V	4772.17(3)	0.018(6)	0.0011(4)
⁴⁸ Ti	3733.627(20)	0.0873(25)	0.00553(16)	⁵¹ V	4883.379(24)	0.073(4)	0.00434(24)
⁴⁸ Ti	3920.404(22)	0.0839(23)	0.00531(15)	⁵¹ V	4992.94(4)	0.036(3)	0.00214(18)
⁴⁸ Ti	3923.4(7)	0.13(3)	0.0082(19)	⁵¹ V	5142.363(23)	0.200(6)	0.0119(4)
⁴⁸ Ti	4713.859(25)	0.0661(21)	0.00418(13)	⁵¹ V	5210.143(19)	0.244(20)	0.0145(12)
⁴⁸ Ti	4881.394(15)	0.308(7)	0.0195(4)	⁵¹ V	5515.813(23)	0.39(4)	0.0232(24)
⁴⁸ Ti	4966.802(15)	0.196(5)	0.0124(3)	⁵¹ V	5551.32(3)	0.027(3)	0.00161(18)
⁴⁸ Ti	6418.426(14)	1.96(6)	0.124(4)	⁵¹ V	5578.358(24)	0.019(3)	0.00113(18)
⁴⁸ Ti	6555.911(14)	0.334(8)	0.0211(5)	⁵¹ V	5752.064(22)	0.366(24)	0.0218(14)
⁴⁸ Ti	6760.084(14)	2.97(9)	0.188(6)	⁵¹ V	5892.101(20)	0.126(7)	0.0075(4)
Vanadium (Z=23), At.Wt.=50.9415(1), σ_γ^Z=4.96(4)				⁵¹ V	6464.887(18)	0.43(4)	0.0256(24)
⁵¹ V	17.152(6)	0.260(20)	0.0155(12)	⁵¹ V	6517.282(19)	0.78(4)	0.0464(24)
⁵¹ V	22.764(3)	0.0700(20)	0.00416(12)	⁵¹ V	6874.157(19)	0.49(6)	0.029(4)
⁵¹ V	124.453(4)	0.23(5)	0.014(3)	⁵¹ V	7162.898(15)	0.59(4)	0.0351(24)
⁵¹ V	125.082(3)	1.61(4)	0.0958(24)	⁵¹ V	7287.961(15)	0.056(4)	0.00333(24)
⁵¹ V	147.846(3)	0.253(6)	0.0151(4)	⁵¹ V	7293.572(16)	0.089(5)	0.0053(3)
⁵¹ V	295.023(14)	0.164(4)	0.00976(24)	⁵¹ V	7310.721(15)	0.227(9)	0.0135(5)
⁵¹ V	419.475(13)	0.249(6)	0.0148(4)	Chromium (Z=24), At.Wt.=51.9961(6), σ_γ^Z=3.07(15)			
⁵¹ V	436.627(13)	0.397(9)	0.0236(5)	⁵⁰ Cr	27.97(7)	0.124(4)	0.00723(23)
⁵¹ V	645.703(13)	0.769(17)	0.0457(10)	⁵² Cr	564.05(12)	0.1130(20)	0.00659(12)
⁵¹ V	682.031(17)	0.0180(10)	0.00107(6)	⁵⁰ Cr	749.09(3)	0.569(9)	0.0332(5)
⁵¹ V	698.104(13)	0.049(4)	0.00291(24)	⁵³ Cr	834.849(22)	1.38(3)	0.0804(17)
⁵¹ V	712.907(19)	0.0597(23)	0.00355(14)	⁵⁰ Cr	888.95(7)	0.015(5)	0.0009(3)
⁵¹ V	793.546(13)	0.199(5)	0.0118(3)	⁵³ Cr	989.074(23)	0.0139(5)	0.00081(3)
⁵¹ V	823.184(13)	0.320(8)	0.0190(5)	⁵⁰ Cr	1149.83(3)	0.0214(4)	0.001247(23)
⁵¹ V	845.948(13)	0.252(7)	0.0150(4)	⁵³ Cr	1241.33(7)	0.0140(5)	0.00082(3)
⁵¹ V	886.631(21)	0.0171(7)	0.00102(4)	⁵⁴ Cr	1528.00(20)d	3.800(12)E-6	2.215E-7[92%]
⁵¹ V	982.175(19)	0.0307(17)	0.00183(10)	⁵³ Cr	1784.70(4)	0.1760(20)	0.01026(12)
⁵¹ V	1001.583(21)	0.0651(21)	0.00387(12)	⁵⁰ Cr	1898.90(3)	0.0852(21)	0.00497(12)
⁵¹ V	1254.878(17)	0.0257(13)	0.00153(8)	⁵³ Cr	1994.52(6)	0.0545(14)	0.00318(8)
⁵¹ V	1270.951(15)	0.022(5)	0.0013(3)	⁵⁰ Cr	2001.05(5)	0.0199(10)	0.00116(6)
				⁵² Cr	2105.8(5)	0.021(4)	0.00122(23)

^A Z	E _γ -keV	σ _γ ^z (E _γ)-barns	k ₀
⁵³ Cr	2239.04(8)	0.186(3)	0.01084(17)
⁵² Cr	2320.8(3)	0.136(3)	0.00793(17)
⁵⁰ Cr	2348.52(7)	0.0164(10)	0.00096(6)
⁵⁰ Cr	2376.49(5)	0.0362(9)	0.00211(5)
⁵³ Cr	2558.19(11)	0.0197(7)	0.00115(4)
⁵³ Cr	2601.79(8)	0.0404(12)	0.00235(7)
⁵² Cr	2669.8(5)	0.0263(12)	0.00153(7)
⁵⁰ Cr	3021.27(12)	0.0139(8)	0.00081(5)
⁵³ Cr	3177.78(15)	0.0234(8)	0.00136(5)
⁵² Cr	3616.7(4)	0.0260(12)	0.00152(7)
⁵³ Cr	3719.70(6)	0.0675(24)	0.00393(14)
⁵² Cr	4322.1(3)	0.0269(15)	0.00157(9)
⁵³ Cr	4847.56(8)	0.0346(15)	0.00202(9)
⁵³ Cr	4871.96(8)	0.0180(10)	0.00105(6)
⁵⁰ Cr	5220.72(12)	0.0184(17)	0.00107(10)
⁵³ Cr	5268.15(11)	0.0465(25)	0.00271(15)
⁵² Cr	5268.9(5)	0.050(6)	0.0029(4)
⁵⁰ Cr	5489.85(14)	0.024(4)	0.00140(23)
⁵⁰ Cr	5493.99(12)	0.016(3)	0.00093(17)
⁵² Cr	5617.9(3)	0.132(5)	0.0077(3)
⁵³ Cr	5706.94(16)	0.024(4)	0.00140(23)
⁵³ Cr	5858.72(9)	0.0266(21)	0.00155(12)
⁵³ Cr	5999.80(7)	0.085(7)	0.0050(4)
⁵⁰ Cr	6134.58(9)	0.078(4)	0.00455(23)
⁵⁴ Cr	6245.89(17)	0.0056(9)	0.00033(5)
⁵³ Cr	6282.90(9)	0.036(3)	0.00210(17)
⁵³ Cr	6326.49(12)	0.0212(23)	0.00124(13)
⁵⁰ Cr	6370.15(10)	0.028(17)	0.0016(10)
⁵³ Cr	6645.61(8)	0.183(13)	0.0107(8)
⁵³ Cr	6890.11(7)	0.042(3)	0.00245(17)
⁵³ Cr	7099.91(6)	0.146(9)	0.0085(5)
⁵⁰ Cr	7361.12(8)	0.092(4)	0.00536(23)
⁵² Cr	7374.49(22)	0.080(4)	0.00466(23)
⁵² Cr	7938.46(23)	0.424(11)	0.0247(6)
⁵⁰ Cr	8482.80(9)	0.169(7)	0.0098(4)
⁵⁰ Cr	8510.77(8)	0.233(8)	0.0136(5)
⁵³ Cr	8884.36(5)	0.78(5)	0.045(3)
⁵³ Cr	9719.06(5)	0.260(18)	0.0152(10)
Manganese (Z=25), At. Wt.=54.938049(9), σ_γ^z=13.36(5)			
⁵⁵ Mn	26.560(20)	3.42(4)	0.1887(22)
⁵⁵ Mn	83.884(23)	3.11(5)	0.172(3)
⁵⁵ Mn	104.611(23)	1.74(3)	0.0960(17)
⁵⁵ Mn	118.77(4)	0.0526(22)	0.00290(12)
⁵⁵ Mn	123.46(4)	0.0612(23)	0.00338(13)
⁵⁵ Mn	188.521(22)	0.330(6)	0.0182(3)
⁵⁵ Mn	212.039(21)	2.13(3)	0.1175(17)
⁵⁵ Mn	215.150(22)	0.168(3)	0.00927(17)
⁵⁵ Mn	230.096(24)	0.193(4)	0.01065(22)
⁵⁵ Mn	271.198(22)	0.94(6)	0.052(3)
⁵⁵ Mn	274.32(5)	0.075(6)	0.0041(3)
⁵⁵ Mn	314.398(20)	1.460(20)	0.0805(11)
⁵⁵ Mn	335.502(24)	0.147(3)	0.00811(17)
⁵⁵ Mn	341.01(3)	0.0912(25)	0.00503(14)
⁵⁵ Mn	354.12(4)	0.093(4)	0.00513(22)
⁵⁵ Mn	375.192(22)	0.124(3)	0.00684(17)
⁵⁵ Mn	454.378(21)	0.388(7)	0.0214(4)
⁵⁵ Mn	459.754(23)	0.210(5)	0.0116(3)
⁵⁵ Mn	499.57(4)	0.0402(20)	0.00222(11)
⁵⁵ Mn	504.74(4)	0.096(4)	0.00530(22)
⁵⁵ Mn	716.20(5)	0.055(3)	0.00303(17)
⁵⁵ Mn	846.754(20)d	13.10(4)	0.7226[12%]
⁵⁵ Mn	1810.72(4)d	3.62(11)	0.200[12%]
⁵⁵ Mn	2016.47(5)	0.0527(25)	0.00291(14)
⁵⁵ Mn	2043.99(5)	0.243(5)	0.0134(3)
⁵⁵ Mn	2045.76(15)	0.0384(23)	0.00212(13)
⁵⁵ Mn	2062.81(4)	0.179(5)	0.0099(3)
⁵⁵ Mn	2113.05(4)d	1.91(5)	0.105[12%]
⁵⁵ Mn	2175.91(5)	0.111(4)	0.00612(22)

^A Z	E _γ -keV	σ _γ ^z (E _γ)-barns	k ₀
⁵⁵ Mn	2210.29(9)	0.080(5)	0.0044(3)
⁵⁵ Mn	2294.42(7)	0.112(6)	0.0062(3)
⁵⁵ Mn	2330.55(7)	0.191(8)	0.0105(4)
⁵⁵ Mn	2469.99(12)	0.083(6)	0.0046(3)
⁵⁵ Mn	2677.20(19)	0.068(10)	0.0038(6)
⁵⁵ Mn	2873.23(11)	0.070(4)	0.00386(22)
⁵⁵ Mn	2953.77(11)	0.069(5)	0.0038(3)
⁵⁵ Mn	3002.85(15)	0.055(5)	0.0030(3)
⁵⁵ Mn	3267.17(7)	0.188(6)	0.0104(3)
⁵⁵ Mn	3408.61(5)	0.303(10)	0.0167(6)
⁵⁵ Mn	3641.21(13)	0.061(5)	0.0034(3)
⁵⁵ Mn	3751.50(15)	0.054(5)	0.0030(3)
⁵⁵ Mn	3813.99(9)	0.088(8)	0.0049(4)
⁵⁵ Mn	3820.48(16)	0.042(5)	0.0023(3)
⁵⁵ Mn	3927.8(3)	0.044(6)	0.0024(3)
⁵⁵ Mn	3979.0(3)	0.039(5)	0.0022(3)
⁵⁵ Mn	4222.85(17)	0.066(5)	0.0036(3)
⁵⁵ Mn	4267.69(12)	0.078(6)	0.0043(3)
⁵⁵ Mn	4379.90(16)	0.073(6)	0.0040(3)
⁵⁵ Mn	4445.06(20)	0.077(8)	0.0042(4)
⁵⁵ Mn	4549.70(23)	0.056(6)	0.0031(3)
⁵⁵ Mn	4566.56(10)	0.197(9)	0.0109(5)
⁵⁵ Mn	4588.23(18)	0.053(5)	0.0029(3)
⁵⁵ Mn	4643.40(13)	0.073(10)	0.0040(6)
⁵⁵ Mn	4689.14(11)	0.120(9)	0.0066(5)
⁵⁵ Mn	4724.84(8)	0.281(10)	0.0155(6)
⁵⁵ Mn	4840.72(16)	0.064(6)	0.0035(3)
⁵⁵ Mn	4874.52(13)	0.069(5)	0.0038(3)
⁵⁵ Mn	4907.36(19)	0.070(7)	0.0039(4)
⁵⁵ Mn	4934.09(18)	0.055(6)	0.0030(3)
⁵⁵ Mn	4949.21(8)	0.274(10)	0.0151(6)
⁵⁵ Mn	4969.28(21)	0.043(5)	0.0024(3)
⁵⁵ Mn	5014.37(7)	0.737(20)	0.0407(11)
⁵⁵ Mn	5034.60(15)	0.108(8)	0.0060(4)
⁵⁵ Mn	5067.87(9)	0.265(12)	0.0146(7)
⁵⁵ Mn	5110.97(22)	0.050(5)	0.0028(3)
⁵⁵ Mn	5180.89(8)	0.412(13)	0.0227(7)
⁵⁵ Mn	5198.52(13)	0.095(7)	0.0052(4)
⁵⁵ Mn	5253.98(12)	0.132(13)	0.0073(7)
⁵⁵ Mn	5403.7(3)	0.050(6)	0.0028(3)
⁵⁵ Mn	5437.71(15)	0.087(7)	0.0048(4)
⁵⁵ Mn	5527.08(8)	0.788(22)	0.0435(12)
⁵⁵ Mn	5761.23(11)	0.200(12)	0.0110(7)
⁵⁵ Mn	5920.39(8)	1.06(3)	0.0585(17)
⁵⁵ Mn	6031.03(18)	0.067(7)	0.0037(4)
⁵⁵ Mn	6104.29(12)	0.213(10)	0.0117(6)
⁵⁵ Mn	6430.04(19)	0.088(7)	0.0049(4)
⁵⁵ Mn	6783.74(12)	0.378(17)	0.0209(9)
⁵⁵ Mn	6929.22(13)	0.248(12)	0.0137(7)
⁵⁵ Mn	7057.89(9)	1.22(3)	0.0673(17)
⁵⁵ Mn	7159.63(10)	0.643(24)	0.0355(13)
⁵⁵ Mn	7243.52(9)	1.36(3)	0.0750(17)
⁵⁵ Mn	7270.14(12)	0.362(15)	0.0200(8)
Iron (Z=26), At. Wt.=55.845(2), σ_γ^z=2.56(13)			
⁵⁶ Fe	14.411(14)	0.149(3)	0.00809(16)
⁵⁶ Fe	122.077(14)	0.096(3)	0.00521(16)
⁵⁶ Fe	136.488(14)	0.0118(3)	0.000640(16)
⁵⁶ Fe	230.270(13)	0.0274(5)	0.00149(3)
⁵⁸ Fe	287.025(19)	0.00218(15)	1.18(8)E-4
⁵⁶ Fe	352.347(12)	0.273(3)	0.01481(16)
⁵⁶ Fe	366.758(10)	0.0497(7)	0.00270(4)
⁵⁴ Fe	411.57(21)	0.022(5)	0.0012(3)
⁵⁶ Fe	569.885(19)	0.0139(3)	0.000754(16)
⁵⁶ Fe	657.46(11)	0.0067(18)	0.00036(10)
⁵⁶ Fe	691.960(19)	0.1370(18)	0.00743(10)
⁵⁷ Fe	810.71(3)	0.0274(9)	0.00149(5)
⁵⁷ Fe	863.80(5)	0.0072(4)	0.000391(22)
⁵⁷ Fe	867.4(4)	~0.007	~0.0004

^A Z	E _γ -keV	σ _γ ^z (E _γ)-barns	k ₀	^A Z	E _γ -keV	σ _γ ^z (E _γ)-barns	k ₀
⁵⁶ Fe	898.27(3)	0.0540(10)	0.00293(5)	⁵⁹ Co	349.954(24)	0.124(4)	0.00638(21)
⁵⁶ Fe	920.839(19)	0.0199(6)	0.00108(3)	⁵⁹Co	391.218(15)	1.080(14)	0.0555(7)
⁵⁶ Fe	1018.93(3)	0.0507(11)	0.00275(6)	⁵⁹Co	435.677(17)	0.789(10)	0.0406(5)
⁵⁶Fe	1260.448(19)	0.0684(11)	0.00371(6)	⁵⁹Co	447.711(19)	3.41(4)	0.1754(21)
⁵⁶ Fe	1358.540(22)	0.0211(6)	0.00115(3)	⁵⁹ Co	461.061(18)	0.519(9)	0.0267(5)
⁵⁶Fe	1612.786(18)	0.1530(22)	0.00830(12)	⁵⁹Co	484.257(16)	0.804(11)	0.0413(6)
⁵⁶ Fe	1627.197(20)	0.0100(5)	0.00054(3)	⁵⁹Co	497.269(16)	2.16(4)	0.1111(21)
⁵⁷ Fe	1674.31(21)	~0.007	~0.0004	⁵⁹Co	555.972(13)	5.76(6)	0.296(3)
⁵⁷ Fe	1674.49(6)	~0.007	~0.0004	⁵⁹ Co	602.71(4)	0.132(7)	0.0068(4)
⁵⁶ Fe	1722.38(10)	0.0074(6)	0.00040(3)	⁵⁹ Co	665.48(3)	0.0769(24)	0.00395(12)
⁵⁶Fe	1725.288(21)	0.181(3)	0.00982(16)	⁵⁹ Co	680.15(3)	0.273(5)	0.0140(3)
⁵⁶ Fe	1810.54(16)	0.0067(7)	0.00036(4)	⁵⁹Co	717.310(18)	0.845(14)	0.0435(7)
⁵⁶ Fe	1965.39(15)	0.0078(14)	0.00042(8)	⁵⁹ Co	726.640(21)	0.448(10)	0.0230(5)
⁵⁶ Fe	2066.08(6)	0.0146(7)	0.00079(4)	⁵⁹ Co	781.79(4)	0.146(6)	0.0075(3)
⁵⁶ Fe	2129.47(7)	0.0206(7)	0.00112(4)	⁵⁹Co	785.628(21)	2.41(7)	0.124(4)
⁵⁴ Fe	2469.24(13)	0.0116(7)	0.00063(4)	⁵⁹ Co	798.97(7)	0.120(10)	0.0062(5)
⁵⁶ Fe	2526.34(7)	0.0112(5)	0.00061(3)	⁵⁹ Co	854.06(4)	0.187(6)	0.0096(3)
⁵⁶ Fe	2682.69(11)	0.0114(9)	0.00062(5)	⁵⁹ Co	862.30(6)	0.079(8)	0.0041(4)
⁵⁶ Fe	2697.10(11)	0.0090(9)	0.00049(5)	⁵⁹ Co	883.11(4)	0.075(5)	0.0039(3)
⁵⁶ Fe	2721.21(4)	0.0384(13)	0.00208(7)	⁵⁹ Co	884.98(4)	0.156(6)	0.0080(3)
⁵⁶ Fe	2755.93(19)	0.015(5)	0.0008(3)	⁵⁹ Co	901.28(3)	0.418(9)	0.0215(5)
⁵⁶ Fe	2832.84(10)	0.0142(22)	0.00077(12)	⁵⁹ Co	908.37(3)	0.100(4)	0.00514(21)
⁵⁶ Fe	2835.82(7)	0.0067(14)	0.00036(8)	⁵⁹ Co	928.48(3)	0.145(9)	0.0075(5)
⁵⁶ Fe	2873.00(7)	0.0099(14)	0.00054(8)	⁵⁹ Co	930.612(23)	0.408(22)	0.0210(11)
⁵⁶ Fe	2954.12(10)	0.0110(7)	0.00060(4)	⁵⁹ Co	944.07(6)	0.18(7)	0.009(4)
⁵⁶ Fe	3103.26(7)	0.0172(7)	0.00093(4)	⁵⁹Co	945.314(17)	0.98(4)	0.0504(21)
⁵⁶ Fe	3168.40(10)	0.0092(7)	0.00050(4)	⁵⁹ Co	947.41(6)	0.121(7)	0.0062(4)
⁵⁶ Fe	3185.86(9)	0.0183(8)	0.00099(4)	⁵⁹ Co	963.58(3)	0.191(11)	0.0098(6)
⁵⁶ Fe	3225.33(7)	0.0105(7)	0.00057(4)	⁵⁹ Co	972.82(16)	0.082(8)	0.0042(4)
⁵⁶ Fe	3239.74(7)	0.0094(13)	0.00051(7)	⁵⁹ Co	1005.668(22)	0.127(6)	0.0065(3)
⁵⁶ Fe	3267.25(8)	0.0367(13)	0.00199(7)	⁵⁹ Co	1023.64(3)	0.22(3)	0.0113(15)
⁵⁶ Fe	3291.06(5)	0.0072(6)	0.00039(3)	⁵⁹ Co	1075.66(10)	0.099(7)	0.0051(4)
⁵⁶ Fe	3356.67(12)	0.0098(6)	0.00053(3)	⁵⁹ Co	1103.73(6)	0.277(12)	0.0142(6)
⁵⁶ Fe	3413.13(5)	0.0449(14)	0.00244(8)	⁵⁹ Co	1117.76(8)	0.106(5)	0.0055(3)
⁵⁶ Fe	3436.66(9)	0.045(4)	0.00244(22)	⁵⁹ Co	1206.47(3)	0.072(11)	0.0037(6)
⁵⁷ Fe	3486.74(11)	0.0114(6)	0.00062(3)	⁵⁹ Co	1207.77(3)	0.202(12)	0.0104(6)
⁵⁶ Fe	3776.90(6)	0.0075(7)	0.00041(4)	⁵⁹ Co	1215.96(3)	0.520(9)	0.0267(5)
⁵⁴ Fe	3790.80(25)	0.0075(7)	0.00041(4)	⁵⁹ Co	1216.44(18)	0.24(22)	0.012(11)
⁵⁶ Fe	3842.43(9)	0.0086(7)	0.00047(4)	⁵⁹ Co	1226.78(5)	0.100(4)	0.00514(21)
⁵⁶ Fe	3854.51(6)	0.0333(12)	0.00181(7)	⁵⁹ Co	1238.566(24)	0.290(7)	0.0149(4)
⁵⁶ Fe	3921.5(8)	0.036(4)	0.00195(22)	⁵⁹ Co	1274.32(4)	0.205(6)	0.0105(3)
⁵⁶Fe	4218.27(5)	0.099(3)	0.00537(16)	⁵⁹ Co	1277.46(3)	0.175(6)	0.0090(3)
⁵⁶ Fe	4274.74(12)	0.0141(8)	0.00077(4)	⁵⁹ Co	1283.22(7)	0.194(6)	0.0100(3)
⁵⁶ Fe	4378.56(8)	0.0067(6)	0.00036(3)	⁵⁹ Co	1334.74(6)	0.155(9)	0.0080(5)
⁵⁶ Fe	4406.07(7)	0.0453(13)	0.00246(7)	⁵⁹ Co	1362.53(4)	0.092(6)	0.0047(3)
⁵⁶ Fe	4463.01(10)	0.0162(11)	0.00088(6)	⁵⁹ Co	1419.30(8)	0.077(6)	0.0040(3)
⁵⁶ Fe	4674.99(11)	0.0125(11)	0.00068(6)	⁵⁹ Co	1472.04(3)	0.195(8)	0.0100(4)
⁵⁶ Fe	4724.54(10)	0.0075(11)	0.00041(6)	⁵⁹ Co	1507.33(3)	0.463(9)	0.0238(5)
⁵⁶ Fe	4809.99(7)	0.0416(13)	0.00226(7)	⁵⁹Co	1515.720(25)	1.740(25)	0.0895(13)
⁵⁶ Fe	4948.70(11)	0.0173(10)	0.00094(5)	⁵⁹ Co	1553.65(3)	0.120(6)	0.0062(3)
⁵⁴ Fe	5507.29(19)	0.0247(15)	0.00134(8)	⁵⁹ Co	1556.08(9)	0.099(6)	0.0051(3)
⁵⁶Fe	5920.449(21)	0.225(5)	0.0122(3)	⁵⁹ Co	1690.72(3)	0.215(14)	0.0111(7)
⁵⁶Fe	6018.532(20)	0.227(5)	0.0123(3)	⁵⁹ Co	1692.83(5)	0.214(14)	0.0110(7)
⁵⁶ Fe	6380.67(3)	0.0187(20)	0.00101(11)	⁵⁹ Co	1703.91(10)	0.074(5)	0.0038(3)
⁵⁶Fe	7278.838(10)	0.137(4)	0.00743(22)	⁵⁹ Co	1774.65(4)	0.30(8)	0.015(4)
⁵⁶Fe	7631.136(14)	0.653(13)	0.0354(7)	⁵⁹ Co	1786.01(17)	0.157(9)	0.0081(5)
⁵⁶Fe	7645.5450(10)	0.549(11)	0.0298(6)	⁵⁹ Co	1787.45(4)	0.08(5)	0.004(3)
⁵⁴ Fe	8886.18(23)	0.0162(12)	0.00088(7)	⁵⁹ Co	1799.92(4)	0.269(7)	0.0138(4)
⁵⁴Fe	9297.68(19)	0.0747(25)	0.00405(14)	⁵⁹ Co	1808.82(7)	0.211(7)	0.0109(4)
Cobalt (Z=27), At. Wt.=58.933200(9), σ_γ^z=37.18(6)				⁵⁹ Co	1808.98(10)	0.15(8)	0.008(4)
⁵⁹ Co	58.603(7)d	0.411(4)	0.02113[75%]	⁵⁹ Co	1818.58(5)	0.179(7)	0.0092(4)
⁵⁹Co	158.517(17)	1.200(15)	0.0617(8)	⁵⁹Co	1830.800(25)	1.700(23)	0.0874(12)
⁵⁹ Co	195.90(3)	0.190(4)	0.00977(21)	⁵⁹ Co	1844.96(8)	0.092(5)	0.0047(3)
⁵⁹ Co	224.12(7)	0.106(23)	0.0055(12)	⁵⁹ Co	1852.70(3)	0.456(10)	0.0234(5)
⁵⁹Co	229.879(17)	7.18(8)	0.369(4)	⁵⁹ Co	1888.77(4)	0.089(6)	0.0046(3)
⁵⁹Co	254.379(17)	1.290(16)	0.0663(8)	⁵⁹ Co	1933.82(8)	0.094(6)	0.0048(3)
⁵⁹ Co	277.161(17)	6.77(8)	0.348(4)	⁵⁹ Co	2022.51(16)	0.082(6)	0.0042(3)
⁵⁹ Co	337.296(18)	0.226(4)	0.01162(21)	⁵⁹ Co	2032.83(7)	0.393(11)	0.0202(6)

A	Z	E_{γ} -keV	$\sigma_{\gamma}^Z(E_{\gamma})$ -barns	k_0	A	Z	E_{γ} -keV	$\sigma_{\gamma}^Z(E_{\gamma})$ -barns	k_0
⁵⁹	Co	2074.83(8)	0.102(9)	0.0052(5)	⁵⁹	Co	5358.44(8)	0.160(8)	0.0082(4)
⁵⁹	Co	2099.19(7)	0.089(8)	0.0046(4)	⁵⁹	Co	5370.21(8)	0.188(9)	0.0097(5)
⁵⁹	Co	2221.61(4)	0.261(8)	0.0134(4)	⁵⁹	Co	5510.56(6)	0.163(11)	0.0084(6)
⁵⁹	Co	2279.78(6)	0.079(11)	0.0041(6)	⁵⁹	Co	5602.97(4)	0.434(16)	0.0223(8)
⁵⁹	Co	2281.57(9)	0.123(11)	0.0063(6)	⁵⁹	Co	5614.67(5)	0.399(15)	0.0205(8)
⁵⁹	Co	2309.66(10)	0.087(6)	0.0045(3)	⁵⁹	Co	5639.03(4)	0.379(15)	0.0195(8)
⁵⁹	Co	2319.46(10)	0.122(7)	0.0063(4)	⁵⁹Co	5660.93(4)	1.89(6)	0.097(3)	
⁵⁹	Co	2453.82(20)	0.072(5)	0.0037(3)	⁵⁹	Co	5704.28(5)	0.177(9)	0.0091(5)
⁵⁹	Co	2527.12(7)	0.146(8)	0.0075(4)	⁵⁹Co	5742.53(4)	0.766(23)	0.0394(12)	
⁵⁹	Co	2557.46(21)	0.086(6)	0.0044(3)	⁵⁹	Co	5852.04(5)	0.110(10)	0.0057(5)
⁵⁹	Co	2569.92(9)	0.154(7)	0.0079(4)	⁵⁹	Co	5925.89(4)	0.643(18)	0.0331(9)
⁵⁹	Co	2607.47(10)	0.165(8)	0.0085(4)	⁵⁹Co	5975.98(4)	2.9(4)	0.149(21)	
⁵⁹	Co	2680.64(24)	0.11(3)	0.0057(15)	⁵⁹	Co	6040.60(4)	0.166(13)	0.0085(7)
⁵⁹	Co	2692.02(15)	0.076(7)	0.0039(4)	⁵⁹	Co	6110.81(6)	0.213(11)	0.0110(6)
⁵⁹	Co	2727.19(13)	0.100(7)	0.0051(4)	⁵⁹	Co	6149.99(7)	0.186(9)	0.0096(5)
⁵⁹	Co	2740.06(18)	0.103(7)	0.0053(4)	⁵⁹	Co	6274.84(3)	0.222(11)	0.0114(6)
⁵⁹	Co	2790.22(20)	0.080(19)	0.0041(10)	⁵⁹	Co	6283.91(4)	0.204(11)	0.0105(6)
⁵⁹	Co	2900.50(24)	0.076(20)	0.0039(10)	⁵⁹Co	6485.99(3)	2.32(5)	0.119(3)	
⁵⁹	Co	2926.19(18)	0.116(8)	0.0060(4)	⁵⁹Co	6706.01(3)	3.02(6)	0.155(3)	
⁵⁹	Co	2978.11(17)	0.075(7)	0.0039(4)	⁵⁹Co	6877.16(3)	3.02(6)	0.155(3)	
⁵⁹	Co	2995.43(13)	0.097(7)	0.0050(4)	⁵⁹	Co	6948.87(3)	0.249(11)	0.0128(6)
⁵⁹	Co	3193.65(16)	0.089(6)	0.0046(3)	⁵⁹Co	6985.41(3)	1.05(13)	0.054(7)	
⁵⁹	Co	3216.43(19)	0.105(13)	0.0054(7)	⁵⁹	Co	7055.92(3)	0.666(19)	0.0342(10)
⁵⁹	Co	3238.16(19)	0.089(8)	0.0046(4)	⁵⁹	Co	7203.22(3)	0.369(16)	0.0190(8)
⁵⁹	Co	3283.78(13)	0.101(8)	0.0052(4)	⁵⁹Co	7214.42(3)	1.38(3)	0.0710(15)	
⁵⁹	Co	3335.29(14)	0.104(7)	0.0053(4)	⁵⁹	Co	7433.07(3)	0.083(7)	0.0043(4)
⁵⁹	Co	3380.22(14)	0.210(10)	0.0108(5)	⁵⁹Co	7491.54(3)	1.16(3)	0.0596(15)	
⁵⁹	Co	3664.13(21)	0.080(9)	0.0041(5)	Nickel (Z=28), At. Wt.=58.6934(2), $\sigma_{\gamma}^Z=4.39(15)$				
⁵⁹	Co	3677.05(13)	0.109(8)	0.0056(4)	⁶²	Ni	155.500(16)	0.0666(12)	0.00344(6)
⁵⁹	Co	3749.21(7)	0.415(13)	0.0213(7)	⁶⁰Ni	282.917(18)	0.211(3)	0.01089(15)	
⁵⁹	Co	3815.20(19)	0.081(7)	0.0042(4)	⁵⁸Ni	339.420(11)	0.1670(21)	0.00862(11)	
⁵⁹	Co	3823.54(19)	0.073(7)	0.0038(4)	⁶²	Ni	362.385(18)	0.0342(5)	0.00177(3)
⁵⁹	Co	3840.83(15)	0.129(8)	0.0066(4)	⁵⁸Ni	464.978(12)	0.843(10)	0.0435(5)	
⁵⁹	Co	3897.02(17)	0.092(7)	0.0047(4)	⁶²	Ni	483.351(20)	0.0156(3)	0.000805(15)
⁵⁹	Co	3929.84(12)	0.272(11)	0.0140(6)	⁶²	Ni	845.733(18)	0.0184(3)	0.000950(15)
⁵⁹	Co	3966.15(18)	0.239(11)	0.0123(6)	⁵⁸Ni	877.977(11)	0.236(3)	0.01219(15)	
⁵⁹	Co	3994.92(24)	0.095(17)	0.0049(9)	⁶¹	Ni	1172.84(5)	0.0122(4)	0.000630(21)
⁵⁹	Co	4026.26(12)	0.272(10)	0.0140(5)	⁵⁸	Ni	1188.781(13)	0.0559(9)	0.00289(5)
⁵⁹	Co	4032.03(18)	0.208(9)	0.0107(5)	⁵⁸	Ni	1301.434(13)	0.052(3)	0.00268(15)
⁵⁹	Co	4148.74(21)	0.086(21)	0.0044(11)	⁵⁸	Ni	1340.230(20)	0.0200(5)	0.00103(3)
⁵⁹	Co	4155.64(24)	0.128(8)	0.0066(4)	⁶⁴	Ni	1481.84(5)d	0.003300(7)	1.704E-4[13%]
⁵⁹	Co	4208.01(12)	0.255(13)	0.0131(7)	⁶⁰	Ni	1502.04(6)	0.0154(4)	0.000795(21)
⁵⁹	Co	4212.56(14)	0.082(9)	0.0042(5)	⁵⁸	Ni	1536.920(16)	0.0194(5)	0.00100(3)
⁵⁹	Co	4329.00(18)	0.105(8)	0.0054(4)	⁵⁸	Ni	1734.687(16)	0.0172(4)	0.000888(21)
⁵⁹	Co	4350.40(12)	0.091(13)	0.0047(7)	⁵⁸	Ni	1949.911(17)	0.0476(10)	0.00246(5)
⁵⁹	Co	4370.46(19)	0.078(12)	0.0040(6)	⁶⁰	Ni	2123.93(3)	0.0379(10)	0.00196(5)
⁵⁹	Co	4377.29(19)	0.119(10)	0.0061(5)	⁵⁸	Ni	2554.116(19)	0.0431(9)	0.00223(5)
⁵⁹	Co	4395.62(11)	0.128(11)	0.0066(6)	⁵⁸	Ni	2842.130(17)	0.0463(10)	0.00239(5)
⁵⁹	Co	4547.05(11)	0.115(9)	0.0059(5)	⁵⁸	Ni	3221.146(23)	0.0157(11)	0.00081(6)
⁵⁹	Co	4607.00(7)	0.311(13)	0.0160(7)	⁵⁸	Ni	3675.24(3)	0.0281(7)	0.00145(4)
⁵⁹	Co	4624.29(16)	0.104(8)	0.0053(4)	⁵⁸	Ni	4858.59(3)	0.0442(10)	0.00228(5)
⁵⁹	Co	4646.83(15)	0.081(10)	0.0042(5)	⁵⁸	Ni	5312.674(24)	0.0536(13)	0.00277(7)
⁵⁹	Co	4666.15(10)	0.085(8)	0.0044(4)	⁵⁸	Ni	5435.77(4)	0.0188(6)	0.00097(3)
⁵⁹	Co	4706.11(13)	0.137(9)	0.0070(5)	⁶⁰	Ni	5695.80(3)	0.0416(12)	0.00215(6)
⁵⁹	Co	4731.06(17)	0.089(8)	0.0046(4)	⁵⁸	Ni	5817.219(20)	0.1090(22)	0.00563(11)
⁵⁹	Co	4884.30(10)	0.237(10)	0.0122(5)	⁶²	Ni	5836.37(3)	0.0348(10)	0.00180(5)
⁵⁹	Co	4893.76(10)	0.217(11)	0.0112(6)	⁵⁸	Ni	5973.06(3)	0.0258(8)	0.00133(4)
⁵⁹	Co	4906.17(7)	0.43(3)	0.0221(15)	⁶⁴	Ni	6034.60(11)	0.013(3)	0.00067(15)
⁵⁹	Co	4921.85(9)	0.285(13)	0.0147(7)	⁵⁸	Ni	6105.215(22)	0.0706(17)	0.00365(9)
⁵⁹	Co	5003.24(8)	0.264(11)	0.0136(6)	⁶²	Ni	6319.67(3)	0.0236(9)	0.00122(5)
⁵⁹	Co	5040.76(16)	0.086(8)	0.0044(4)	⁵⁸	Ni	6583.831(19)	0.0830(20)	0.00429(10)
⁵⁹	Co	5068.69(9)	0.109(10)	0.0056(5)	⁶²Ni	6837.50(3)	0.458(8)	0.0236(4)	
⁵⁹	Co	5127.84(9)	0.205(12)	0.0105(6)	⁶⁰Ni	7536.637(25)	0.190(4)	0.00981(21)	
⁵⁹	Co	5150.08(9)	0.302(13)	0.0155(7)	⁵⁸	Ni	7697.163(18)	0.0374(14)	0.00193(7)
⁵⁹Co	5181.77(7)	0.912(23)	0.0469(12)		⁶⁰Ni	7819.517(21)	0.336(6)	0.0173(3)	
⁵⁹	Co	5211.98(6)	0.072(11)	0.0037(6)	⁵⁸	Ni	8120.567(16)	0.133(3)	0.00687(15)
⁵⁹	Co	5217.09(20)	0.081(10)	0.0042(5)	⁵⁸Ni	8533.509(17)	0.721(13)	0.0372(7)	
⁵⁹	Co	5270.15(4)	0.404(11)	0.0208(6)	⁵⁸Ni	8998.414(15)	1.49(3)	0.0769(15)	

^A Z	E _γ -keV	σ _γ ^Z (E _γ)-barns	k ₀
Copper (Z=29), At.Wt.=63.546(3), σ_γ^Z=3.795(17)			
⁶⁵ Cu	89.08(4)	0.0970(17)	0.00463(8)
⁶³ Cu	159.281(5)	0.648(10)	0.0309(5)
⁶³ Cu	184.618(13)	0.0106(9)	0.00051(4)
⁶⁵ Cu	185.96(4)	0.244(3)	0.01164(14)
⁶³ Cu	202.950(8)	0.193(3)	0.00920(14)
⁶³ Cu	212.389(15)	0.0362(9)	0.00173(4)
⁶³ Cu	214.99(7)	0.0112(14)	0.00053(7)
⁶⁵ Cu	237.80(4)	0.0230(4)	0.001097(19)
⁶³ Cu	247.58(6)	0.0119(15)	0.00057(7)
⁶³ Cu	261.33(8)	0.0095(14)	0.00045(7)
⁶³ Cu	264.869(22)	0.0289(7)	0.00138(3)
⁶³ Cu	278.250(14)	0.893(15)	0.0426(7)
⁶⁵ Cu	315.69(4)	0.0250(4)	0.001192(19)
⁶³ Cu	318.80(4)	0.0120(4)	0.000572(19)
⁶³ Cu	330.52(3)	0.0107(8)	0.00051(4)
⁶³ Cu	343.898(14)	0.215(4)	0.01025(19)
⁶³ Cu	376.80(3)	0.0250(6)	0.00119(3)
⁶³ Cu	384.45(5)	0.0700(14)	0.00334(7)
⁶⁵ Cu	385.77(3)	0.1310(18)	0.00625(9)
⁶⁵ Cu	436.909(20)	0.0112(4)	0.000534(19)
⁶³ Cu	449.486(22)	0.0382(10)	0.00182(5)
⁶³ Cu	460.78(3)	0.0143(5)	0.000682(24)
⁶⁵ Cu	465.14(3)	0.1350(21)	0.00644(10)
⁶³ Cu	467.95(5)	0.0668(14)	0.00319(7)
⁶³ Cu	494.81(5)	0.0242(6)	0.00115(3)
⁶³ Cu	503.41(4)	0.0596(13)	0.00284(6)
⁶³ Cu	533.25(11)	0.0148(8)	0.00071(4)
⁶³ Cu	534.28(5)	0.021(6)	0.0010(3)
⁶⁵ Cu	543.86(3)	0.0256(5)	0.001221(24)
⁶³ Cu	579.75(3)	0.0898(15)	0.00428(7)
⁶³ Cu	608.766(23)	0.270(6)	0.0129(3)
⁶³ Cu	617.47(6)	0.0270(4)	0.001288(19)
⁶³ Cu	632.24(4)	0.0092(4)	0.000439(19)
⁶³ Cu	648.80(3)	0.102(3)	0.00486(14)
⁶³ Cu	662.69(4)	0.072(3)	0.00343(14)
⁶³ Cu	739.03(3)	0.0096(3)	0.000458(14)
⁶³ Cu	767.77(3)	0.0254(17)	0.00121(8)
⁶⁵ Cu	822.673(24)	0.0238(17)	0.00114(8)
⁶⁵ Cu	831.14(4)	0.0160(10)	0.00076(5)
⁶³ Cu	878.17(5)	0.0421(20)	0.00201(10)
⁶³ Cu	897.07(17)	0.0102(4)	0.000486(19)
⁶³ Cu	927.05(3)	0.0119(3)	0.000568(14)
⁶³ Cu	946.65(7)	0.0091(8)	0.00043(4)
⁶³ Cu	962.76(4)	0.0152(9)	0.00072(4)
⁶⁵ Cu	972.11(3)	0.0115(7)	0.00055(3)
⁶⁵ Cu	997.63(3)	0.0093(11)	0.00044(5)
⁶³ Cu	1019.59(4)	0.0141(12)	0.00067(6)
⁶⁵ Cu	1038.97(3)d	0.0598(13)	0.00285[88%]
⁶⁵ Cu	1052.01(5)	0.0117(8)	0.00056(4)
⁶³ Cu	1076.44(4)	0.0097(5)	0.000463(24)
⁶³ Cu	1081.72(3)	0.0117(3)	0.000558(14)
⁶³ Cu	1138.82(3)	0.0296(10)	0.00141(5)
⁶³ Cu	1158.833(15)	0.0267(6)	0.00127(3)
⁶³ Cu	1194.92(4)	0.0106(3)	0.000506(14)
⁶⁵ Cu	1212.53(4)	0.0105(5)	0.000501(24)
⁶³ Cu	1231.98(4)	0.0110(3)	0.000525(14)
⁶³ Cu	1241.52(9)	0.0345(16)	0.00165(8)
⁶³ Cu	1242.61(9)	0.0181(22)	0.00086(10)
⁶³ Cu	1298.10(3)	0.0147(7)	0.00070(3)
⁶³ Cu	1320.25(8)	0.0263(10)	0.00125(5)
⁶⁵ Cu	1355.16(3)	0.0133(16)	0.00063(8)
⁶³ Cu	1361.75(4)	0.0167(5)	0.000796(24)
⁶³ Cu	1417.27(6)	0.0097(4)	0.000463(19)
⁶³ Cu	1438.66(4)	0.013(6)	0.0006(3)
⁶⁵ Cu	1439.37(5)	0.0111(16)	0.00053(8)
⁶³ Cu	1521.03(4)	0.0143(5)	0.000682(24)
⁶⁵ Cu	1559.84(7)	0.0305(10)	0.00145(5)

^A Z	E _γ -keV	σ _γ ^Z (E _γ)-barns	k ₀
⁶⁵ Cu	1582.50(4)	0.0094(7)	0.00045(3)
⁶⁵ Cu	1637.46(5)	0.0135(15)	0.00064(7)
⁶³ Cu	1682.98(7)	0.0167(8)	0.00080(4)
⁶⁵ Cu	1743.30(7)	0.014(4)	0.00067(19)
⁶³ Cu	1852.57(8)	0.0141(10)	0.00067(5)
⁶³ Cu	2141.61(12)	0.0091(5)	0.000434(24)
⁶³ Cu	2153.51(5)	0.0105(11)	0.00050(5)
⁶³ Cu	2291.40(10)	0.0115(8)	0.00055(4)
⁶³ Cu	2497.85(7)	0.0252(13)	0.00120(6)
⁶³ Cu	2932.30(13)	0.0101(7)	0.00048(3)
⁶³ Cu	3152.95(16)	0.0099(9)	0.00047(4)
⁶³ Cu	3315.5(3)	0.0097(7)	0.00046(3)
⁶³ Cu	3464.49(14)	0.0094(15)	0.00045(7)
⁶³ Cu	3588.50(9)	0.0122(14)	0.00058(7)
⁶³ Cu	3844.49(15)	0.0176(11)	0.00084(5)
⁶³ Cu	4089.19(14)	0.0090(5)	0.000429(24)
⁶³ Cu	4133.04(12)	0.0138(10)	0.00066(5)
⁶³ Cu	4204.26(19)	0.0091(5)	0.000434(24)
⁶³ Cu	4286.55(15)	0.0121(6)	0.00058(3)
⁶³ Cu	4312.76(24)	0.0104(8)	0.00050(4)
⁶³ Cu	4319.92(9)	0.047(5)	0.00224(24)
⁶⁵ Cu	4384.92(9)	0.0206(12)	0.00098(6)
⁶³ Cu	4404.91(18)	0.0111(5)	0.000529(24)
⁶³ Cu	4443.9(3)	0.0110(11)	0.00052(5)
⁶³ Cu	4475.88(13)	0.0171(6)	0.00082(3)
⁶³ Cu	4503.94(12)	0.0174(7)	0.00083(3)
⁶³ Cu	4563.20(7)	0.0112(5)	0.000534(24)
⁶³ Cu	4603.01(20)	0.0196(6)	0.00093(3)
⁶³ Cu	4658.55(9)	0.0278(7)	0.00133(3)
⁶³ Cu	5019.16(12)	0.0100(15)	0.00048(7)
⁶⁵ Cu	5042.68(6)	0.0346(14)	0.00165(7)
⁶⁵ Cu	5047.56(7)	0.0206(14)	0.00098(7)
⁶³ Cu	5085.54(11)	0.0118(5)	0.000563(24)
⁶³ Cu	5151.98(15)	0.0096(4)	0.000458(19)
⁶³ Cu	5183.55(17)	0.0132(6)	0.00063(3)
⁶³ Cu	5189.81(11)	0.0241(7)	0.00115(3)
⁶⁵ Cu	5245.59(4)	0.043(3)	0.00205(14)
⁶³ Cu	5258.73(7)	0.0372(9)	0.00177(4)
⁶⁵ Cu	5320.08(8)	0.0362(21)	0.00173(10)
⁶³ Cu	5408.64(17)	0.0144(6)	0.00069(3)
⁶³ Cu	5418.45(5)	0.0668(12)	0.00319(6)
⁶³ Cu	5555.38(19)	0.0098(5)	0.000467(24)
⁶³ Cu	5614.96(12)	0.0178(6)	0.00085(3)
⁶³ Cu	5636.11(7)	0.0147(5)	0.000701(24)
⁶³ Cu	5771.47(9)	0.0183(8)	0.00087(4)
⁶³ Cu	5823.60(20)	0.0108(22)	0.00052(10)
⁶³ Cu	6010.80(5)	0.0574(12)	0.00274(6)
⁶⁵ Cu	6048.73(5)	0.0101(6)	0.00048(3)
⁶³ Cu	6063.24(9)	0.0218(6)	0.00104(3)
⁶³ Cu	6166.7(3)	0.0133(21)	0.00063(10)
⁶⁵ Cu	6243.14(4)	0.0144(9)	0.00069(4)
⁶³ Cu	6321.58(6)	0.0130(5)	0.000620(24)
⁶³ Cu	6394.76(5)	0.0503(10)	0.00240(5)
⁶³ Cu	6595.52(8)	0.0227(8)	0.00108(4)
⁶⁵ Cu	6600.63(4)	0.085(5)	0.00405(24)
⁶³ Cu	6617.66(5)	0.0407(11)	0.00194(5)
⁶³ Cu	6673.15(9)	0.053(3)	0.00253(14)
⁶³ Cu	6674.76(5)	0.0719(21)	0.00343(10)
⁶⁵ Cu	6680.00(4)	0.081(6)	0.0039(3)
⁶⁵ Cu	6790.72(4)	0.0155(10)	0.00074(5)
⁶³ Cu	6988.68(5)	0.126(6)	0.0060(3)
⁶³ Cu	7037.55(5)	0.0140(7)	0.00067(3)
⁶⁵ Cu	7065.72(4)	0.0132(8)	0.00063(4)
⁶³ Cu	7169.51(5)	0.0109(7)	0.00052(3)
⁶³ Cu	7176.68(5)	0.0925(17)	0.00441(8)
⁶³ Cu	7253.01(5)	0.1500(23)	0.00715(11)
⁶³ Cu	7306.93(4)	0.321(17)	0.0153(8)
⁶³ Cu	7571.77(4)	0.0629(12)	0.00300(6)

^A Z	E _γ -keV	σ _γ ^z (E _γ)-barns	k ₀	^A Z	E _γ -keV	σ _γ ^z (E _γ)-barns	k ₀
⁶³ Cu	7637.40(4)	0.54(7)	0.026(3)	⁶⁴ Zn	3109.05(25)	0.0073(10)	0.00034(5)
⁶³ Cu	7756.36(4)	0.0571(12)	0.00272(6)	⁶⁷ Zn	3287.02(9)	0.0088(9)	0.00041(4)
⁶³ Cu	7915.62(4)	0.869(20)	0.0414(10)	⁶⁷ Zn	3331.21(20)	0.0049(5)	2.27(23)E-4
Zinc (Z=30), At. Wt.=65.39(2), σ_γ^z=1.30(8)				⁶⁷ Zn	3458.14(17)	0.0048(4)	2.22(19)E-4
⁶⁴ Zn	53.972(17)	0.0109(6)	0.00051(3)	⁶⁷ Zn	3832.94(25)	0.0048(5)	2.22(23)E-4
⁶⁴ Zn	61.2530(20)	0.0290(9)	0.00134(4)	⁶⁸ Zn	4071.4(4)	0.0036(5)	1.67(23)E-4
⁶⁶ Zn	91.267(5)	0.0046(3)	2.13(14)E-4	⁶⁸ Zn	4103.3(3)	0.0089(21)	0.00041(10)
⁶⁶ Zn	93.311(5)	0.0344(8)	0.00159(4)	⁶⁸ Zn	4137.29(10)	0.0205(25)	0.00095(12)
⁶⁴ Zn	115.225(18)	0.167(3)	0.00774(14)	⁶⁸ Zn	4430.69(14)	0.0055(13)	0.00025(6)
⁶⁴ Zn	153.095(21)	0.0322(6)	0.00149(3)	⁶⁷ Zn	4504.5(4)	0.0042(13)	1.9(6)E-4
⁶⁶ Zn	184.578(6)	0.0321(4)	0.001488(19)	⁶⁴ Zn	4582.9(4)	0.00507(10)	2.35(5)E-4
⁶⁴ Zn	207.067(22)	0.0101(3)	0.000468(14)	⁶⁸ Zn	4652.3(4)	0.0059(7)	0.00027(3)
⁶⁶ Zn	300.219(7)	0.0201(6)	0.00093(3)	⁶⁷ Zn	4782.8(3)	0.0045(4)	2.09(19)E-4
⁶⁶ Zn	393.530(7)	0.00486(22)	2.25(10)E-4	⁶⁷ Zn	4795.0(11)	0.0037(9)	1.7(4)E-4
⁶⁸ Zn	417.30(4)	0.0043(5)	1.99(23)E-4	⁶⁴ Zn	4828.4(3)	0.00676(11)	0.000313(5)
⁶⁸ Zn	434.03(3)	0.0128(16)	0.00059(7)	⁶⁴ Zn	4870.0(3)	0.00380(10)	1.76(5)E-4
⁶⁸ Zn	438.634(18)d	0.0128(5)	0.000593[2.5%]	⁶⁸ Zn	4887.82(13)	0.0080(10)	0.00037(5)
⁶⁸ Zn	531.44(3)	0.0163(20)	0.00076(9)	⁶⁷ Zn	4899.63(19)	0.0053(5)	2.46(23)E-4
⁶⁷ Zn	578.48(5)	0.0121(5)	0.000561(23)	⁶⁷ Zn	4914.15(20)	0.0044(4)	2.04(19)E-4
⁶⁴ Zn	653.51(7)	0.0050(14)	2.3(7)E-4	⁶⁸ Zn	5229.78(11)	0.0044(5)	2.04(23)E-4
⁶⁶ Zn	749.29(7)	0.0058(13)	0.00027(6)	⁶⁷ Zn	5245.84(15)	0.0058(6)	0.00027(3)
⁶⁴ Zn	751.69(3)	0.0307(10)	0.00142(5)	⁶⁷ Zn	5287.4(3)	0.0048(6)	2.2(3)E-4
⁶⁸ Zn	759.29(9)	0.0039(5)	1.81(23)E-4	⁶⁷ Zn	5346.37(21)	0.0039(6)	1.8(3)E-4
⁶⁴ Zn	768.74(7)	0.0040(4)	1.85(19)E-4	⁶⁷ Zn	5402.8(5)	0.0043(24)	2.0(11)E-4
⁶⁴ Zn	794.44(3)	0.0089(5)	0.000412(23)	⁶⁸Zn 5474.02(10)	0.042(5)	0.00195(23)	
⁶⁷ Zn	805.79(3)	0.045(3)	0.00209(14)	⁶⁴ Zn	5521.5(3)	0.0076(11)	0.00035(5)
⁶⁸ Zn	834.77(3)	0.037(5)	0.00171(23)	⁶⁴ Zn	5541.0(5)	0.0047(7)	2.2(3)E-4
⁶⁴ Zn	855.69(3)	0.066(6)	0.0031(3)	⁶⁴ Zn	5559.82(15)	0.01110(15)	0.000514(7)
⁶⁴ Zn	864.43(6)	0.0094(6)	0.00044(3)	⁶⁸ Zn	5647.05(10)	0.0082(10)	0.00038(5)
⁶⁴ Zn	909.66(3)	0.0187(8)	0.00087(4)	⁶⁷ Zn	5662.23(18)	0.0066(8)	0.00031(4)
⁶⁴ Zn	932.10(6)	0.0047(4)	2.18(19)E-4	⁶⁷ Zn	5677.3(3)	0.0053(7)	2.5(3)E-4
⁶⁶ Zn	958.24(7)	0.0058(5)	0.000269(23)	⁶⁷ Zn	5685.90(19)	0.0051(4)	2.36(19)E-4
⁶⁴ Zn	993.35(6)	0.0059(6)	0.00027(3)	⁶⁴ Zn	5776.31(10)	0.01360(17)	0.000630(8)
⁶⁸ Zn	1007.809(25)	0.056(7)	0.0026(3)	⁶⁷ Zn	5789.15(21)	0.0045(6)	2.1(3)E-4
⁶⁴ Zn	1047.32(7)	0.0036(5)	1.67(23)E-4	⁶⁶ Zn	5909.4(3)	0.0110(11)	0.00051(5)
⁶⁷ Zn	1077.335(16)	0.356(5)	0.01650(23)	⁶⁴ Zn	6037.28(8)	0.01490(20)	0.000691(9)
⁶⁷ Zn	1126.100(25)	0.0229(6)	0.00106(3)	⁶⁷ Zn	6262.43(12)	0.0085(6)	0.00039(3)
⁶⁸ Zn	1178.55(9)	0.0102(13)	0.00047(6)	⁶⁸ Zn	6481.75(10)	0.0100(12)	0.00046(6)
⁶⁸ Zn	1252.07(5)	0.0073(9)	0.00034(4)	⁶⁴ Zn	6509.27(8)	0.01190(16)	0.000552(7)
⁶⁷ Zn	1261.15(3)	0.0431(10)	0.00200(5)	⁶⁶ Zn	6658.6(3)	0.019(4)	0.00088(19)
⁶⁴ Zn	1262.58(6)	0.0053(15)	2.5(7)E-4	⁶⁷ Zn	6701.79(12)	0.0066(4)	0.000306(19)
⁶⁴ Zn	1293.02(8)	0.0061(6)	0.00028(3)	⁶⁷ Zn	6768.21(10)	0.0112(9)	0.00052(4)
⁶⁷ Zn	1300.96(6)	0.010(4)	0.00046(19)	⁶⁶ Zn	6867.5(3)	0.0254(17)	0.00118(8)
⁶⁷ Zn	1340.14(3)	0.0457(16)	0.00212(7)	⁶⁷ Zn	6910.58(11)	0.0194(14)	0.00090(7)
⁶⁴ Zn	1354.42(5)	0.0103(9)	0.00048(4)	⁶⁶Zn 6958.8(3)	0.043(3)	0.00199(14)	
⁶⁴ Zn	1415.67(5)	0.0043(7)	2.0(3)E-4	⁶⁴ Zn	7069.20(7)	0.0204(3)	0.000945(14)
⁶⁷ Zn	1546.33(8)	0.0082(7)	0.00038(3)	⁶⁴ Zn	7111.95(7)	0.0198(3)	0.000918(14)
⁶⁴ Zn	1593.0(3)	0.0053(13)	2.5(6)E-4	⁶⁷ Zn	7188.40(8)	0.0131(7)	0.00061(3)
⁶⁸ Zn	1594.05(9)	0.0051(6)	2.4(3)E-4	⁶⁷ Zn	7859.07(8)	0.0084(7)	0.00039(3)
⁶⁷ Zn	1673.46(4)	0.0260(10)	0.00120(5)	⁶⁴Zn 7863.55(7)	0.1410(19)	0.00653(9)	
⁶⁷ Zn	1744.47(5)	0.0147(7)	0.00068(3)	⁶⁷ Zn	8314.37(8)	0.0105(5)	0.000487(23)
⁶⁸ Zn	1813.18(8)	0.0051(6)	2.4(3)E-4	⁶⁷ Zn	9120.06(7)	0.0136(6)	0.00063(3)
⁶⁴ Zn	1826.45(6)	0.0161(10)	0.00075(5)	Gallium (Z=31), At. Wt.=69.723(1), σ_γ^z=2.90(7)			
⁶⁷ Zn	1882.09(10)	0.0056(15)	0.00026(7)	⁷¹ Ga	16.43(3)	0.078(5)	0.00339(22)
⁶⁷ Zn	1883.12(3)	0.0718(18)	0.00333(8)	⁷¹ Ga	41.89(4)	0.0050(4)	2.17(17)E-4
⁶⁴ Zn	2087.44(9)	0.0047(6)	2.2(3)E-4	⁷¹ Ga	46.97(4)	0.013(3)	0.00057(13)
⁶⁷ Zn	2106.74(6)	0.0071(7)	0.00033(3)	⁷¹ Ga	79.75(4)	0.0224(10)	0.00097(4)
⁶⁷ Zn	2209.73(9)	0.0269(13)	0.00125(6)	⁷¹ Ga	88.86(4)	0.0305(9)	0.00133(4)
⁶⁴ Zn	2212.10(16)	0.0071(17)	0.00033(8)	⁷¹ Ga	103.25(3)d	0.0526(11)	0.00229[100%]
⁶⁸ Zn	2344.60(8)	0.0100(12)	0.00046(6)	⁷¹ Ga	110.06(4)	0.0118(8)	0.00051(4)
⁶⁷ Zn	2347.58(14)	0.0048(7)	2.2(3)E-4	⁷¹ Ga	112.36(3)	0.155(3)	0.00674(13)
⁶⁷ Zn	2352.10(8)	0.0059(9)	0.00027(4)	⁷¹ Ga	121.01(3)	0.0142(6)	0.00062(3)
⁶⁸ Zn	2378.6(3)	0.0039(5)	1.81(23)E-4	⁷¹ Ga	128.76(4)	0.0063(9)	0.00027(4)
⁶⁷ Zn	2418.53(10)	0.0095(7)	0.00044(3)	⁷¹ Ga	132.07(11)	0.013(3)	0.00057(13)
⁶⁴ Zn	2432.3(5)	0.0037(8)	1.7(4)E-4	⁷¹ Ga	145.14(3)	0.466(7)	0.0203(3)
⁶⁷ Zn	2648.75(21)	0.0056(10)	0.00026(5)	⁷¹ Ga	153.78(3)	0.0319(8)	0.00139(4)
⁶⁷ Zn	2698.91(17)	0.0061(9)	0.00028(4)	⁷¹ Ga	162.90(4)	0.021(5)	0.00091(22)
⁶⁷ Zn	2857.91(10)	0.0070(8)	0.00032(4)	⁷¹ Ga	181.54(4)	0.040(3)	0.00174(13)

^A Z	E _γ -keV	σ _γ ^Z (E _γ)-barns	k ₀	^A Z	E _γ -keV	σ _γ ^Z (E _γ)-barns	k ₀
⁷¹ Ga	184.09(3)	0.1040(21)	0.00452(9)	⁷¹ Ga	1217.5(9)	0.0075(21)	0.00033(9)
⁶⁹ Ga	187.84(3)	0.1080(21)	0.00469(9)	⁷¹ Ga	1296.9(7)	0.0065(9)	0.00028(4)
⁷¹ Ga	192.11(3)	0.194(3)	0.00843(13)	⁶⁹ Ga	1306.73(12)	0.0140(20)	0.00061(9)
⁷¹ Ga	194.66(4)	0.1070(21)	0.00465(9)	⁶⁹ Ga	1311.89(6)	0.0259(12)	0.00113(5)
⁷¹ Ga	197.94(5)	0.1330(24)	0.00578(10)	⁶⁹ Ga	1359.50(9)	0.0148(11)	0.00064(5)
⁷¹ Ga	210.37(11)	0.019(7)	0.0008(3)	⁷¹ Ga	1359.53(17)	0.0148(11)	0.00064(5)
⁷¹ Ga	210.50(20)	0.0343(8)	0.00149(4)	⁶⁹ Ga	1456.39(7)	0.0168(11)	0.00073(5)
⁷¹ Ga	212.58(4)	0.0583(12)	0.00253(5)	⁷¹ Ga	1464.00(7)d	0.0609(19)	0.00265[2.4%]
⁷¹ Ga	228.97(4)	0.0379(10)	0.00165(4)	⁶⁹ Ga	1518.21(8)	0.0219(13)	0.00095(6)
⁷¹ Ga	231.06(4)	0.0111(6)	0.00048(3)	⁷¹ Ga	1532.91(17)	0.0172(12)	0.00075(5)
⁷¹ Ga	246.91(20)	0.0118(19)	0.00051(8)	⁷¹ Ga	1596.68(8)d	0.0732(16)	0.00318[2.4%]
⁷¹ Ga	248.89(4)	0.136(8)	0.0059(4)	⁶⁹ Ga	1621.55(12)	0.0096(10)	0.00042(4)
⁷¹ Ga	264.03(4)	0.0238(9)	0.00103(4)	⁶⁹ Ga	1725.48(8)	0.0108(7)	0.00047(3)
⁷¹ Ga	266.14(3)	0.0361(11)	0.00157(5)	⁶⁹ Ga	1794.15(13)	0.0088(9)	0.00038(4)
⁷¹ Ga	306.11(14)	0.015(4)	0.00065(17)	⁶⁹ Ga	1846.5(3)	0.0053(10)	2.3(4)E-4
⁷¹ Ga	306.62(12)	0.0097(8)	0.00042(4)	⁷¹ Ga	1861.09(6)d	0.0904(19)	0.00393[2.4%]
⁷¹ Ga	313.62(11)	0.0209(8)	0.00091(4)	⁶⁹ Ga	1866.6(5)	0.0060(17)	0.00026(7)
⁷¹ Ga	315.40(6)	0.0275(9)	0.00120(4)	⁶⁹ Ga	1907.63(13)	0.0089(11)	0.00039(5)
⁶⁹ Ga	318.87(3)	0.0592(14)	0.00257(6)	⁶⁹ Ga	1930.5(3)	0.0058(11)	0.00025(5)
⁶⁹ Ga	344.79(7)	0.0070(6)	0.00030(3)	⁶⁹ Ga	2115.98(17)	0.0066(8)	0.00029(4)
⁶⁹ Ga	363.93(13)	0.0048(6)	2.1(3)E-4	⁶⁹ Ga	2142.88(14)	0.0085(9)	0.00037(4)
⁶⁹ Ga	374.37(4)	0.0303(10)	0.00132(4)	⁶⁹ Ga	2164.1(7)	0.0056(13)	2.4(6)E-4
⁷¹ Ga	384.17(5)	0.0058(6)	0.00025(3)	⁷¹ Ga	2201.91(13)d	0.52(4)	0.0226[2.4%]
⁷¹ Ga	390.66(4)	0.0476(12)	0.00207(5)	⁷¹ Ga	2491.6(3)d	0.17(4)	0.0074[2.4%]
⁶⁹ Ga	393.26(3)	0.021(3)	0.00091(13)	⁷¹ Ga	2507.40(12)d	0.28(4)	0.0122[2.4%]
⁷¹ Ga	393.28(3)	0.1340(23)	0.00582(10)	⁷¹ Ga	3034.6(4)d	0.15(3)	0.0065[2.4%]
⁷¹ Ga	402.86(4)	0.0172(8)	0.00075(4)	⁷¹ Ga	4543.3(5)	0.0104(11)	0.00045(5)
⁷¹ Ga	408.44(20)	0.0179(9)	0.00078(4)	⁷¹ Ga	4578.2(7)	0.0058(12)	0.00025(5)
⁷¹ Ga	411.07(14)	0.019(5)	0.00083(22)	⁷¹ Ga	4595.4(5)	0.0093(13)	0.00040(6)
⁷¹ Ga	411.13(4)	0.0384(11)	0.00167(5)	⁷¹ Ga	4686.8(5)	0.0066(9)	0.00029(4)
⁷¹ Ga	439.26(6)	0.0154(7)	0.00067(3)	⁷¹ Ga	4719.2(9)	0.0052(8)	2.3(4)E-4
⁷¹ Ga	444.65(6)	0.021(5)	0.00091(22)	⁷¹ Ga	4761.5(4)	0.0078(9)	0.00034(4)
⁷¹ Ga	458.54(12)	0.0092(7)	0.00040(3)	⁷¹ Ga	4792.6(3)	0.0207(17)	0.00090(7)
⁷¹ Ga	488.81(4)	0.0227(8)	0.00099(4)	⁷¹ Ga	4839.89(23)	0.040(3)	0.00174(13)
⁷¹ Ga	488.81(4)	0.017(4)	0.00074(17)	⁷¹ Ga	4868.2(3)	0.0189(14)	0.00082(6)
⁶⁹ Ga	508.19(3)	0.349(6)	0.0152(3)	⁷¹ Ga	4890.5(3)	0.0191(14)	0.00083(6)
⁶⁹ Ga	516.564(25)	0.012(4)	0.00052(17)	⁶⁹ Ga	4955.2(4)	0.0095(13)	0.00041(6)
⁷¹ Ga	547.90(5)	0.0090(8)	0.00039(4)	⁷¹ Ga	5054.0(4)	0.0094(11)	0.00041(5)
⁶⁹ Ga	561.97(5)	0.0078(3)	0.000339(13)	⁷¹ Ga	5091.8(9)	0.0070(9)	0.00030(4)
⁷¹ Ga	564.29(5)	0.0097(3)	0.000422(13)	⁶⁹ Ga	5133.6(6)	0.0051(11)	2.2(5)E-4
⁷¹ Ga	579.55(12)	0.0068(9)	0.00030(4)	⁷¹ Ga	5160.69(21)	0.0154(13)	0.00067(6)
⁷¹ Ga	601.21(6)d	0.471(22)	0.0205[2.4%]	⁶⁹ Ga	5189.2(9)	0.0074(20)	0.00032(9)
⁷¹ Ga	603.24(4)	0.0155(7)	0.00067(3)	⁷¹ Ga	5195.1(5)	0.034(3)	0.00148(13)
⁷¹ Ga	619.63(5)	0.0053(12)	2.3(5)E-4	⁷¹ Ga	5223.3(7)	0.0157(13)	0.00068(6)
⁷¹ Ga	620.23(14)	0.0052(11)	2.3(5)E-4	⁷¹ Ga	5233.57(25)	0.0344(19)	0.00150(8)
⁷¹ Ga	629.96(5)d	0.490(22)	0.0213[2.4%]	⁷¹ Ga	5272.7(6)	0.0057(15)	2.5(7)E-4
⁶⁹ Ga	632.34(4)	0.0183(7)	0.00080(3)	⁷¹ Ga	5313.3(8)	0.0049(10)	2.1(4)E-4
⁶⁹ Ga	651.09(3)	0.1030(22)	0.00448(10)	⁶⁹ Ga	5334.13(18)	0.0271(18)	0.00118(8)
⁶⁹ Ga	690.943(24)	0.305(4)	0.01326(17)	⁷¹ Ga	5334.9(5)	0.020(7)	0.0009(3)
⁷¹ Ga	786.17(16)d	0.160(22)	0.0070[2.4%]	⁷¹ Ga	5340.45(25)	0.0406(21)	0.00176(9)
⁷¹ Ga	834.08(3)d	1.65(5)	0.0717[2.4%]	⁷¹ Ga	5390.2(5)	0.0049(10)	2.1(4)E-4
⁶⁹ Ga	851.34(7)	0.0127(9)	0.00055(4)	⁷¹ Ga	5487.2(13)	0.0090(25)	0.00039(11)
⁶⁹ Ga	868.3(3)	0.0071(15)	0.00031(7)	⁶⁹ Ga	5488.31(17)	0.0296(19)	0.00129(8)
⁷¹ Ga	894.84(20)	0.0111(9)	0.00048(4)	⁷¹ Ga	5497.6(5)	0.0091(13)	0.00040(6)
⁷¹ Ga	894.91(11)d	0.35(3)	0.0152[2.4%]	⁶⁹ Ga	5510.0(4)	0.0047(9)	2.0(4)E-4
⁶⁹ Ga	904.91(7)	0.0149(10)	0.00065(4)	⁷¹ Ga	5543.83(19)	0.0142(17)	0.00062(7)
⁷¹ Ga	976.37(13)	0.0101(8)	0.00044(4)	⁷¹ Ga	5577.0(6)	0.0058(18)	0.00025(8)
⁶⁹ Ga	995.68(5)	0.0173(9)	0.00075(4)	⁷¹ Ga	5601.75(25)	0.063(4)	0.00274(17)
⁷¹ Ga	1002.71(25)	0.0073(8)	0.00032(4)	⁷¹ Ga	5625.35(24)	0.0077(16)	0.00033(7)
⁶⁹ Ga	1010.34(6)	0.0146(8)	0.00063(4)	⁷¹ Ga	5644.8(7)	0.0065(21)	0.00028(9)
⁶⁹ Ga	1014.99(8)	0.0077(7)	0.00033(3)	⁷¹ Ga	5651.3(4)	0.0134(20)	0.00058(9)
⁶⁹ Ga	1044.90(15)	0.0107(11)	0.00047(5)	⁷¹ Ga	5664.0(5)	0.0099(11)	0.00043(5)
⁷¹ Ga	1050.69(5)d	0.119(13)	0.0052[2.4%]	⁷¹ Ga	5692.2(3)	0.0211(13)	0.00092(6)
⁷¹ Ga	1051.25(17)	0.0114(10)	0.00050(4)	⁷¹ Ga	5721.1(13)	0.020(4)	0.00087(17)
⁷¹ Ga	1075.6(5)	0.0053(8)	2.3(4)E-4	⁶⁹ Ga	5722.9(3)	0.0067(25)	0.00029(11)
⁶⁹ Ga	1140.37(4)	0.0422(16)	0.00183(7)	⁷¹ Ga	5779.11(18)	0.022(4)	0.00096(17)
⁷¹ Ga	1200.3(3)	0.0078(9)	0.00034(4)	⁶⁹ Ga	5783.8(4)	0.0114(13)	0.00050(6)
⁶⁹ Ga	1203.40(6)	0.0286(14)	0.00124(6)	⁶⁹ Ga	5806.4(3)	0.0152(15)	0.00066(7)

^A Z	E _γ -keV	σ _γ ^z (E _γ)-barns	k ₀	^A Z	E _γ -keV	σ _γ ^z (E _γ)-barns	k ₀
⁷¹ Ga	5883.55(19)	0.0096(4)	0.000417(17)	⁷⁶ Ge	1250.55(10)	0.0110(21)	0.00046(9)
⁷¹ Ga	5900.55(14)	0.0173(14)	0.00075(6)	⁷² Ge	1251.30(7)	0.032(9)	0.0013(4)
⁷¹ Ga	5919.38(15)	0.0131(12)	0.00057(5)	⁷⁰ Ge	1298.61(6)	0.049(4)	0.00204(17)
⁷¹ Ga	6007.25(14)	0.069(5)	0.00300(22)	⁷³ Ge	1332.081(11)	0.0122(10)	0.00051(4)
⁷¹ Ga	6111.72(24)	0.055(4)	0.00239(17)	⁷⁰ Ge	1378.73(6)	0.017(4)	0.00071(17)
⁷¹ Ga	6127.57(14)	0.0227(23)	0.00099(10)	⁷³ Ge	1471.712(10)	0.083(3)	0.00346(13)
⁶⁹ Ga	6134.5(5)	0.0058(14)	0.00025(6)	⁷³ Ge	1489.491(24)	0.0234(12)	0.00098(5)
⁷¹ Ga	6190.14(17)	0.0218(19)	0.00095(8)	⁷³ Ge	1509.719(11)	0.0422(17)	0.00176(7)
⁶⁹ Ga	6238.6(4)	0.0067(10)	0.00029(4)	⁷³ Ge	1513.41(8)	~0.01	~0.0005
⁷¹ Ga	6311.64(14)	0.0194(16)	0.00084(7)	⁷³ Ge	1513.74(9)	~0.01	~0.0005
⁷¹ Ga	6322.20(14)	0.0186(16)	0.00081(7)	⁷³ Ge	1573.87(3)	0.0115(9)	0.00048(4)
⁶⁹ Ga	6346.4(3)	0.0140(15)	0.00061(7)	⁷³ Ge	1617.539(14)	0.0197(12)	0.00082(5)
⁷¹ Ga	6358.61(14)	0.138(5)	0.00600(22)	⁷⁰ Ge	1631.1(3)	0.0189(13)	0.00079(5)
⁶⁹ Ga	6513.06(18)	0.0325(20)	0.00141(9)	⁷³ Ge	1631.83(7)	0.0175(12)	0.00073(5)
⁷¹ Ga	6520.12(14)	0.017(3)	0.00074(13)	⁷³ Ge	1635.84(7)	0.0138(11)	0.00058(5)
⁶⁹ Ga	7002.30(16)	0.0203(12)	0.00088(5)	⁷³ Ge	1640.749(12)	0.0128(10)	0.00053(4)
Germanium (Z=32), At. Wt.=72.64(1), σ_γ^z=2.30(6)				⁷³ Ge	1712.780(20)	0.0129(9)	0.00054(4)
⁷² Ge	68.750(17)	0.0201(7)	0.00084(3)	⁷³ Ge	1755.86(3)	0.014(4)	0.00058(17)
⁷⁰ Ge	175.05(3)	0.164(4)	0.00684(17)	⁷³ Ge	1940.422(12)	0.0382(16)	0.00159(7)
⁷⁰ Ge	175.05(3)d	0.078(5)	0.00325[100%]	⁷⁰ Ge	1964.98(5)	0.0112(11)	0.00047(5)
⁷⁴ Ge	177.49(4)	0.0118(5)	0.000492(21)	⁷³ Ge	2014.478(24)	0.0127(12)	0.00053(5)
⁷⁰ Ge	247.27(5)	0.0123(6)	0.000513(25)	⁷³ Ge	2073.746(14)	0.0205(14)	0.00086(6)
⁷⁴ Ge	253.21(5)	0.0609(16)	0.00254(7)	⁷³ Ge	4423.23(6)	0.014(3)	0.00058(13)
⁷² Ge	284.98(5)	0.0164(7)	0.00068(3)	⁷³ Ge	4423.81(8)	0.014(4)	0.00058(17)
⁷² Ge	297.41(3)	0.0414(12)	0.00173(5)	⁷⁴ Ge	4706.98(23)	0.0151(13)	0.00063(5)
⁷⁰ Ge	306.18(4)	0.0136(8)	0.00057(3)	⁷⁰ Ge	4881.79(4)	0.017(3)	0.00071(13)
⁷² Ge	325.74(3)	0.0649(18)	0.00271(8)	⁷³ Ge	5165.56(5)	0.013(9)	0.0005(4)
⁷⁰ Ge	326.83(3)	0.058(5)	0.00242(21)	⁷³ Ge	5361.77(6)	0.0111(12)	0.00046(5)
⁷⁰ Ge	391.43(4)	0.0253(10)	0.00106(4)	⁷⁰ Ge	5383.85(7)	0.0131(15)	0.00055(6)
⁷² Ge	430.34(5)	0.0161(7)	0.00067(3)	⁷⁰ Ge	5450.69(5)	0.028(4)	0.00117(17)
⁷² Ge	432.86(5)	0.0125(6)	0.000521(25)	⁷² Ge	5518.30(4)	0.0290(17)	0.00121(7)
⁷³ Ge	492.933(5)	0.133(3)	0.00555(13)	⁷² Ge	5650.80(6)	0.0115(12)	0.00048(5)
⁷⁰ Ge	499.87(3)	0.162(6)	0.00676(25)	⁷² Ge	5740.07(10)	0.0151(15)	0.00063(6)
⁷³ Ge	516.19(4)	~0.02	~0.0008	⁷⁰ Ge	5817.17(4)	0.028(3)	0.00117(13)
⁷⁰ Ge	517.78(8)	0.0114(10)	0.00048(4)	⁷⁰ Ge	6036.90(6)	0.045(3)	0.00188(13)
⁷³ Ge	531.654(7)	0.0133(7)	0.00055(3)	⁷⁰ Ge	6117.02(7)	0.043(6)	0.00179(25)
⁷² Ge	541.77(4)	0.0154(6)	0.000642(25)	⁷³ Ge	6199.96(5)	0.0120(13)	0.00050(5)
⁷⁰ Ge	572.27(5)	0.018(4)	0.00075(17)	⁷⁴ Ge	6251.97(6)	0.0188(18)	0.00078(8)
⁷⁴ Ge	574.91(3)	0.0306(12)	0.00128(5)	⁷³ Ge	6265.84(6)	0.015(4)	0.00063(17)
⁷³ Ge	595.851(5)	1.100(24)	0.0459(10)	⁷⁰ Ge	6276.35(6)	0.0214(21)	0.00089(9)
⁷³ Ge	606.80(4)	0.015(12)	0.0006(5)	⁷⁰ Ge	6320.19(5)	0.0153(14)	0.00064(6)
⁷³ Ge	608.353(4)	0.250(6)	0.01043(25)	⁷² Ge	6390.29(5)	0.0299(19)	0.00125(8)
⁷³ Ge	701.509(8)	0.0642(19)	0.00268(8)	⁷² Ge	6418.62(4)	0.0178(15)	0.00074(6)
⁷⁰ Ge	708.15(3)	0.0825(24)	0.00344(10)	⁷⁰ Ge	6707.43(3)	0.0388(25)	0.00162(10)
⁷³ Ge	770.211(8)	0.0135(8)	0.00056(3)	⁷² Ge	6716.00(4)	0.0160(15)	0.00067(6)
⁷⁰ Ge	788.60(7)	0.014(3)	0.00058(13)	⁷³ Ge	6717.462(23)	0.020(5)	0.00083(21)
⁷⁰ Ge	808.14(4)	0.030(5)	0.00125(21)	⁷⁰ Ge	6915.69(3)	0.031(5)	0.00129(21)
⁷³ Ge	808.218(10)	0.0197(18)	0.00082(8)	⁷³ Ge	7091.164(15)	0.0170(11)	0.00071(5)
⁷⁰ Ge	831.30(3)	0.0445(16)	0.00186(7)	⁷³ Ge	7260.187(14)	0.0270(15)	0.00113(6)
⁷⁰ Ge	851.70(13)	0.012(7)	0.0005(3)	⁷⁰ Ge	7415.510(23)	0.016(5)	0.00067(21)
⁷³ Ge	867.899(5)	0.553(12)	0.0231(5)	⁷³ Ge	8030.317(13)	0.0117(9)	0.00049(4)
⁷³ Ge	878.130(19)	0.0112(8)	0.00047(3)	⁷³ Ge	8498.388(13)	0.0120(9)	0.00050(4)
⁷³ Ge	939.249(11)	0.0315(13)	0.00131(5)	⁷³ Ge	8731.744(13)	0.0128(8)	0.00053(3)
⁷³ Ge	961.055(7)	0.129(4)	0.00538(17)	Arsenic (Z=33), At. Wt.=74.92160(2), σ_γ^z=4.23(8)			
⁷³ Ge	999.775(8)	0.0581(19)	0.00242(8)	⁷⁵ As	44.4250(10)	0.560(20)	0.0227(8)
⁷⁰ Ge	1095.42(5)	0.053(5)	0.00221(21)	⁷⁵ As	46.0980(10)	0.337(15)	0.0136(6)
⁷⁰ Ge	1098.62(5)	0.0165(10)	0.00069(4)	⁷⁵ As	74.8720(10)	0.12(3)	0.0049(12)
⁷³ Ge	1101.282(6)	0.134(3)	0.00559(13)	⁷⁵ As	81.4110(20)	0.0107(15)	0.00043(6)
⁷³ Ge	1105.557(10)	0.0708(20)	0.00295(8)	⁷⁵ As	83.2840(10)	0.0142(16)	0.00057(7)
⁷³ Ge	1131.360(8)	0.0487(15)	0.00203(6)	⁷⁵ As	86.7880(10)	0.579(11)	0.0234(4)
⁷⁰ Ge	1139.27(6)	0.0441(23)	0.00184(10)	⁷⁵ As	91.3670(10)	0.0218(17)	0.00088(7)
⁷³ Ge	1150.441(22)	0.0127(8)	0.00053(3)	⁷⁵ As	116.7550(10)	0.107(18)	0.0043(7)
⁷³ Ge	1200.75(10)	~0.01	~0.0005	⁷⁵ As	117.3320(10)	0.071(18)	0.0029(7)
⁷³ Ge	1200.89(18)	~0.01	~0.0005	⁷⁵ As	118.680(3)	0.0140(10)	0.00057(4)
⁷³ Ge	1200.94(3)	~0.01	~0.0005	⁷⁵ As	120.2580(10)	0.402(8)	0.0163(3)
⁷³ Ge	1204.199(6)	0.141(4)	0.00588(17)	⁷⁵ As	122.2470(10)	0.227(5)	0.00918(20)
⁷³ Ge	1205.862(13)	0.0114(21)	0.00048(9)	⁷⁵ As	127.5090(20)	0.096(3)	0.00388(12)
⁷³ Ge	1228.20(9)	0.0116(9)	0.00048(4)	⁷⁵ As	135.4110(10)	0.156(4)	0.00631(16)

^A Z	E _γ -keV	σ _γ ^Z (E _γ)-barns	k ₀	^A Z	E _γ -keV	σ _γ ^Z (E _γ)-barns	k ₀
⁷⁵ As	136.3430(10)	0.031(3)	0.00125(12)	⁷⁵ As	473.1540(10)	0.176(5)	0.00712(20)
⁷⁵ As	137.0270(10)	0.0391(19)	0.00158(8)	⁷⁵ As	477.584(9)	0.0124(18)	0.00050(7)
⁷⁵ As	141.2150(20)	0.0625(21)	0.00253(9)	⁷⁵ As	479.102(5)	0.0115(17)	0.00047(7)
⁷⁵ As	142.4590(10)	0.0211(16)	0.00085(7)	⁷⁵ As	480.137(6)	0.0126(18)	0.00051(7)
⁷⁵ As	144.5480(10)	0.1000(22)	0.00404(9)	⁷⁵ As	487.393(4)	0.0139(20)	0.00056(8)
⁷⁵ As	152.8430(20)	0.0114(13)	0.00046(5)	⁷⁵ As	494.105(7)	0.0100(17)	0.00040(7)
⁷⁵ As	155.0830(10)	0.0423(19)	0.00171(8)	⁷⁵ As	506.4970(20)	0.0283(23)	0.00114(9)
⁷⁵ As	156.8900(20)	0.0136(18)	0.00055(7)	⁷⁵ As	517.873(10)	0.024(3)	0.00097(12)
⁷⁵ As	157.7450(10)	0.117(24)	0.0047(10)	⁷⁵ As	529.907(8)	0.0111(18)	0.00045(7)
⁷⁵ As	162.6820(10)	0.0257(19)	0.00104(8)	⁷⁵ As	550.460(3)	0.071(3)	0.00287(12)
⁷⁵ As	165.0490(10)	0.996(16)	0.0403(7)	⁷⁵ As	554.937(24)	0.0230(24)	0.00093(10)
⁷⁵ As	178.0190(10)	0.0979(23)	0.00396(9)	⁷⁵ As	559.10(5)d	2.00(10)	0.081[1.3%]
⁷⁵ As	178.831(3)	0.0169(11)	0.00068(4)	⁷⁵ As	565.547(7)	0.0463(25)	0.00187(10)
⁷⁵ As	180.121(3)	0.0136(7)	0.00055(3)	⁷⁵ As	582.291(5)	0.0115(15)	0.00047(6)
⁷⁵ As	180.2100(10)	0.0157(8)	0.00064(3)	⁷⁵ As	585.492(8)	0.0161(17)	0.00065(7)
⁷⁵ As	186.0720(10)	0.0285(17)	0.00115(7)	⁷⁵ As	624.685(6)	0.0225(20)	0.00091(8)
⁷⁵ As	186.734(3)	0.0103(6)	0.000417(24)	⁷⁵ As	628.7440(10)	0.0116(17)	0.00047(7)
⁷⁵ As	187.3130(20)	0.0152(8)	0.00061(3)	⁷⁵ As	632.396(24)	0.0219(20)	0.00089(8)
⁷⁵ As	188.0620(10)	0.090(3)	0.00364(12)	⁷⁵ As	640.119(10)	0.0141(20)	0.00057(8)
⁷⁵ As	191.2620(20)	0.0117(17)	0.00047(7)	⁷⁵ As	644.329(23)	0.015(3)	0.00061(12)
⁷⁵ As	193.273(3)	0.0119(15)	0.00048(6)	⁷⁵ As	657.05(5)d	0.279(14)	0.0113[1.3%]
⁷⁵ As	198.8550(10)	0.089(3)	0.00360(12)	⁷⁵ As	669.113(4)	0.0278(13)	0.00112(5)
⁷⁵ As	200.446(3)	0.011(3)	0.00044(12)	⁷⁵ As	687.103(8)	0.010(5)	0.00040(20)
⁷⁵ As	201.1800(20)	0.0140(18)	0.00057(7)	⁷⁵ As	687.618(7)	0.0126(15)	0.00051(6)
⁷⁵ As	211.1470(10)	0.113(3)	0.00457(12)	⁷⁵ As	706.783(4)	0.0339(22)	0.00137(9)
⁷⁵ As	220.3810(10)	0.0373(23)	0.00151(9)	⁷⁵ As	725.909(24)	0.0118(18)	0.00048(7)
⁷⁵ As	221.5320(10)	0.0534(25)	0.00216(10)	⁷⁵ As	731.840(9)	0.0102(17)	0.00041(7)
⁷⁵ As	224.004(4)	0.0126(12)	0.00051(5)	⁷⁵ As	822.346(23)	0.0303(22)	0.00123(9)
⁷⁵ As	225.7020(10)	0.0803(24)	0.00325(10)	⁷⁵ As	848.593(9)	0.0282(21)	0.00114(9)
⁷⁵ As	235.8770(10)	0.181(4)	0.00732(16)	⁷⁵ As	859.76(22)	0.0210(21)	0.00085(9)
⁷⁵ As	238.9960(10)	0.023(10)	0.0009(4)	⁷⁵ As	880.326(9)	0.0234(21)	0.00095(9)
⁷⁵ As	241.6580(10)	0.0262(13)	0.00106(5)	⁷⁵ As	941.116(13)	0.0194(19)	0.00078(8)
⁷⁵ As	246.2030(20)	0.0223(14)	0.00090(6)	⁷⁵ As	942.240(8)	0.0161(8)	0.00065(3)
⁷⁵ As	256.0350(10)	0.045(11)	0.0018(4)	⁷⁵ As	944.229(8)	0.0146(19)	0.00059(8)
⁷⁵ As	263.8940(10)	0.18(4)	0.0073(16)	⁷⁵ As	1216.08(5)d	0.155(8)	0.0063[1.3%]
⁷⁵ As	271.7540(10)	0.013(4)	0.00053(16)	⁷⁵ As	5527.02(12)	0.0112(7)	0.00045(3)
⁷⁵ As	281.5750(10)	0.085(20)	0.0034(8)	⁷⁵ As	5533.94(3)	0.151(7)	0.0061(3)
⁷⁵ As	297.248(10)	0.010(4)	0.00040(16)	⁷⁵ As	5540.51(15)	0.0131(9)	0.00053(4)
⁷⁵ As	297.5420(10)	0.055(3)	0.00222(12)	⁷⁵ As	5546.04(8)	0.0181(11)	0.00073(4)
⁷⁵ As	300.4610(10)	0.051(3)	0.00206(12)	⁷⁵ As	5568.99(5)	0.0354(18)	0.00143(7)
⁷⁵ As	301.654(7)	0.0109(24)	0.00044(10)	⁷⁵ As	5580.21(3)	0.019(3)	0.00077(12)
⁷⁵ As	306.639(9)	0.011(3)	0.00044(12)	⁷⁵ As	5601.37(7)	0.0138(8)	0.00056(3)
⁷⁵ As	308.3190(10)	0.018(3)	0.00073(12)	⁷⁵ As	5612.9(4)	0.0103(21)	0.00042(9)
⁷⁵ As	311.004(5)	0.0161(25)	0.00065(10)	⁷⁵ As	5614.99(13)	0.015(3)	0.00061(12)
⁷⁵ As	314.243(3)	0.031(3)	0.00125(12)	⁷⁵ As	5629.53(7)	0.0181(11)	0.00073(4)
⁷⁵ As	322.572(4)	0.016(3)	0.00065(12)	⁷⁵ As	5645.75(8)	0.0119(7)	0.00048(3)
⁷⁵ As	326.9120(20)	0.015(3)	0.00061(12)	⁷⁵ As	5655.22(6)	0.0172(9)	0.00070(4)
⁷⁵ As	330.100(7)	0.023(3)	0.00093(12)	⁷⁵ As	5663.81(3)	0.019(4)	0.00077(16)
⁷⁵ As	340.1560(20)	0.0413(21)	0.00167(9)	⁷⁵ As	5675.89(3)	0.026(4)	0.00105(16)
⁷⁵ As	352.3620(20)	0.071(3)	0.00287(12)	⁷⁵ As	5684.20(4)	0.0414(19)	0.00167(8)
⁷⁵ As	357.4070(10)	0.074(3)	0.00299(12)	⁷⁵ As	5690.54(3)	0.023(4)	0.00093(16)
⁷⁵ As	360.3830(20)	0.0228(14)	0.00092(6)	⁷⁵ As	5698.05(3)	0.0479(22)	0.00194(9)
⁷⁵ As	363.9040(10)	0.059(3)	0.00239(12)	⁷⁵ As	5723.39(7)	0.0160(9)	0.00065(4)
⁷⁵ As	378.976(3)	0.030(3)	0.00121(12)	⁷⁵ As	5757.22(3)	0.015(3)	0.00061(12)
⁷⁵ As	379.3230(20)	0.0231(20)	0.00093(8)	⁷⁵ As	5778.12(3)	0.0482(23)	0.00195(9)
⁷⁵ As	384.002(5)	0.0186(18)	0.00075(7)	⁷⁵ As	5786.82(3)	0.026(4)	0.00105(16)
⁷⁵ As	394.231(8)	0.0131(20)	0.00053(8)	⁷⁵ As	5816.39(5)	0.0247(12)	0.00100(5)
⁷⁵ As	399.3490(20)	0.0465(23)	0.00188(9)	⁷⁵ As	5834.21(7)	0.0210(11)	0.00085(4)
⁷⁵ As	402.7440(20)	0.061(3)	0.00247(12)	⁷⁵ As	5854.92(13)	0.0218(16)	0.00088(7)
⁷⁵ As	412.7930(20)	0.0117(12)	0.00047(5)	⁷⁵ As	5869.65(7)	0.015(4)	0.00061(16)
⁷⁵ As	426.5750(10)	0.100(3)	0.00404(12)	⁷⁵ As	5877.68(6)	0.0276(14)	0.00112(6)
⁷⁵ As	428.187(3)	0.0130(14)	0.00053(6)	⁷⁵ As	5884.72(3)	0.0504(24)	0.00204(10)
⁷⁵ As	430.7920(20)	0.0134(12)	0.00054(5)	⁷⁵ As	5906.24(8)	0.0128(8)	0.00052(3)
⁷⁵ As	436.8030(10)	0.0113(12)	0.00046(5)	⁷⁵ As	5931.22(9)	0.0143(9)	0.00058(4)
⁷⁵ As	460.7790(20)	0.0111(10)	0.00045(4)	⁷⁵ As	5942.97(9)	0.0119(7)	0.00048(3)
⁷⁵ As	463.647(3)	0.0333(23)	0.00135(9)	⁷⁵ As	5970.12(5)	0.0210(10)	0.00085(4)
⁷⁵ As	467.965(13)	0.0165(19)	0.00067(8)	⁷⁵ As	5976.18(5)	0.0199(10)	0.00080(4)
⁷⁵ As	471.0000(10)	0.203(5)	0.00821(20)	⁷⁵ As	6006.34(5)	0.0297(15)	0.00120(6)

A	Z	E_{γ} -keV	$\sigma_{\gamma}^Z(E_{\gamma})$ -barns	k_0	A	Z	E_{γ} -keV	$\sigma_{\gamma}^Z(E_{\gamma})$ -barns	k_0
⁷⁵	As	6014.00(8)	0.0224(12)	0.00091(5)	⁷⁶	Se	303.7930(20)	0.052(3)	0.00200(12)
⁷⁵	As	6019.17(11)	0.0161(10)	0.00065(4)	⁷⁶	Se	331.2210(20)	0.0526(25)	0.00202(10)
⁷⁵	As	6027.524(22)	0.020(3)	0.00081(12)	⁷⁶	Se	368.733(4)	0.026(3)	0.00100(12)
⁷⁵	As	6059.483(22)	0.026(3)	0.00105(12)	⁷⁶	Se	378.9540(20)	0.022(3)	0.00084(12)
⁷⁵	As	6142.79(3)	0.014(3)	0.00057(12)	⁷⁶	Se	384.9800(20)	0.032(5)	0.00123(19)
⁷⁵	As	6171.99(9)	0.0105(6)	0.000425(24)	⁷⁶	Se	390.8920(20)	0.029(4)	0.00111(15)
⁷⁵	As	6180.14(5)	0.0264(13)	0.00107(5)	⁷⁸	Se	432.12(14)	0.0227(15)	0.00087(6)
⁷⁵	As	6203.57(4)	0.016(3)	0.00065(12)	⁷⁶	Se	439.4510(20)	0.319(8)	0.0122(3)
⁷⁵	As	6223.06(3)	0.012(3)	0.00049(12)	⁸⁰	Se	467.81(10)	0.128(4)	0.00491(15)
⁷⁵	As	6231.24(4)	0.0413(19)	0.00167(8)	⁷⁶	Se	484.5440(20)	0.125(4)	0.00480(15)
⁷⁵	As	6294.295(25)	0.064(6)	0.00259(24)	⁸⁰	Se	491.46(22)	0.022(3)	0.00084(12)
⁷⁵	As	6303.71(22)	0.024(4)	0.00097(16)	⁷⁶	Se	504.7970(20)	0.024(5)	0.00092(19)
⁷⁵	As	6305.37(3)	0.085(4)	0.00344(16)	⁷⁶	Se	518.1810(20)	0.273(7)	0.0105(3)
⁷⁵	As	6342.976(15)	0.010(3)	0.00040(12)	⁷⁶	Se	520.6370(20)	1.260(18)	0.0484(7)
⁷⁵	As	6357.58(7)	0.0204(10)	0.00083(4)	⁷⁷	Se	545.297(12)	0.0635(25)	0.00244(10)
⁷⁵	As	6370.124(9)	0.0274(13)	0.00111(5)	⁷⁶	Se	565.7300(20)	0.0398(23)	0.00153(9)
⁷⁵	As	6388.768(10)	0.0329(18)	0.00133(7)	⁷⁶	Se	568.0660(20)	0.103(8)	0.0040(3)
⁷⁵	As	6393.133(12)	0.032(4)	0.00129(16)	⁷⁶	Se	569.185(4)	0.024(8)	0.0009(3)
⁷⁵	As	6403.761(12)	0.022(3)	0.00089(12)	⁷⁶	Se	574.6420(20)	0.054(3)	0.00207(12)
⁷⁵	As	6419.378(23)	0.031(4)	0.00125(16)	⁷⁶	Se	578.8550(20)	0.243(5)	0.00933(19)
⁷⁵	As	6465.17(12)	0.0111(24)	0.00045(10)	⁷⁶	Se	585.4320(20)	0.077(4)	0.00296(15)
⁷⁵	As	6526.051(13)	0.0123(7)	0.00050(3)	⁷⁶	Se	607.471(4)	0.027(5)	0.00104(19)
⁷⁵	As	6534.932(9)	0.0316(15)	0.00128(6)	⁷⁶	Se	610.3800(20)	0.0345(21)	0.00132(8)
⁷⁵	As	6542.669(10)	0.0408(19)	0.00165(8)	⁷⁴	Se	610.7130(20)	0.0316(22)	0.00121(8)
⁷⁵	As	6583.556(10)	0.027(3)	0.00109(12)	⁷⁷	Se	613.724(3)	2.14(5)	0.0821(19)
⁷⁵	As	6587.038(13)	0.045(3)	0.00182(12)	⁷⁶	Se	645.8300(20)	0.099(3)	0.00380(12)
⁷⁵	As	6600.71(3)	0.0372(17)	0.00150(7)	⁷⁷	Se	687.251(5)	0.063(5)	0.00242(19)
⁷⁵	As	6620.59(5)	0.0304(15)	0.00123(6)	⁷⁷	Se	694.914(4)	0.443(10)	0.0170(4)
⁷⁵	As	6659.378(9)	0.0227(11)	0.00092(4)	⁷⁶	Se	707.9800(20)	0.0281(20)	0.00108(8)
⁷⁵	As	6691.241(9)	0.0246(12)	0.00100(5)	⁷⁶	Se	749.6060(20)	0.042(3)	0.00161(12)
⁷⁵	As	6699.744(8)	0.0109(7)	0.00044(3)	⁷⁶	Se	755.3920(20)	0.186(4)	0.00714(15)
⁷⁵	As	6718.514(11)	0.0101(6)	0.000409(24)	⁷⁶	Se	817.8520(20)	0.174(5)	0.00668(19)
⁷⁵	As	6778.047(9)	0.0143(9)	0.00058(4)	⁷⁷	Se	828.188(12)	0.0300(17)	0.00115(7)
⁷⁵	As	6784.456(9)	0.0133(25)	0.00054(10)	⁷⁶	Se	881.840(4)	0.040(3)	0.00154(12)
⁷⁵	As	6808.872(8)	0.160(8)	0.0065(3)	⁷⁷	Se	884.867(7)	0.100(6)	0.00384(23)
⁷⁵	As	6810.898(8)	0.56(3)	0.0227(12)	⁷⁶	Se	885.8270(20)	0.262(7)	0.0101(3)
⁷⁵	As	6823.272(8)	0.0133(8)	0.00054(3)	⁷⁷	Se	889.095(9)	0.096(6)	0.00368(23)
⁷⁵	As	6828.896(9)	0.0161(9)	0.00065(4)	⁷⁶	Se	889.108(4)	0.180(5)	0.00691(19)
⁷⁵	As	6857.474(8)	0.0168(10)	0.00068(4)	⁷⁶	Se	890.981(5)	0.083(4)	0.00319(15)
⁷⁵	As	6881.302(8)	0.0162(9)	0.00066(4)	⁷⁶	Se	946.9760(20)	0.089(4)	0.00342(15)
⁷⁵	As	6926.635(8)	0.061(4)	0.00247(16)	⁷⁶	Se	951.809(6)	0.047(3)	0.00180(12)
⁷⁵	As	6976.101(9)	0.0130(21)	0.00053(9)	⁷⁶	Se	990.377(4)	0.028(3)	0.00107(12)
⁷⁵	As	7020.139(8)	0.104(7)	0.0042(3)	⁷⁶	Se	991.629(6)	0.057(5)	0.00219(19)
⁷⁵	As	7027.998(8)	0.0534(25)	0.00216(10)	⁷⁶	Se	1005.1770(20)	0.117(5)	0.00449(19)
⁷⁵	As	7048.154(8)	0.0103(21)	0.00042(9)	⁷⁶	Se	1091.64(3)	0.026(5)	0.00100(19)
⁷⁵	As	7063.648(8)	0.045(3)	0.00182(12)	⁷⁶	Se	1128.104(4)	0.023(4)	0.00088(15)
⁷⁵	As	7163.396(8)	0.0181(9)	0.00073(4)	⁷⁷	Se	1144.952(16)	0.076(3)	0.00292(12)
⁷⁵	As	7208.183(8)	0.0127(7)	0.00051(3)	⁷⁶	Se	1161.828(5)	0.079(4)	0.00303(15)
⁷⁵	As	7241.649(8)	0.0167(20)	0.00068(8)	⁷⁶	Se	1163.476(4)	0.087(4)	0.00334(15)
⁷⁵	As	7284.007(8)	0.036(3)	0.00146(12)	⁷⁶	Se	1172.617(5)	0.058(3)	0.00223(12)
Selenium (Z=34), At. Wt.=78.96(3), $\sigma_{\gamma}^Z=12.0(7)$									
⁷⁶	Se	51.3610(10)	~0.03	~0.001	⁷⁶	Se	1186.973(3)	0.033(3)	0.00127(12)
⁷⁶	Se	87.8660(10)	0.210(4)	0.00806(15)	⁷⁶	Se	1194.111(10)	0.022(3)	0.00084(12)
⁷⁴	Se	112.3880(10)	0.0317(15)	0.00122(6)	⁷⁷	Se	1198.72(10)	0.0379(23)	0.00145(9)
⁷⁶	Se	125.8440(10)	0.074(17)	0.0028(7)	⁸⁰	Se	1202.0(3)	0.037(3)	0.00142(12)
⁷⁶	Se	139.2270(10)	0.543(9)	0.0208(4)	⁷⁷	Se	1240.206(12)	0.106(4)	0.00407(15)
⁷⁴	Se	141.3140(20)	0.0246(21)	0.00094(8)	⁷⁶	Se	1296.986(7)	0.240(7)	0.0092(3)
⁷⁶	Se	161.9220(10)d	0.855(23)	0.0328[99%]	⁷⁶	Se	1306.540(10)	0.061(6)	0.00234(23)
⁷⁶	Se	180.751(3)	0.0291(12)	0.00112(5)	⁷⁷	Se	1308.632(5)	0.317(8)	0.0122(3)
⁷⁶	Se	200.4530(20)	0.233(9)	0.0089(4)	⁷⁷	Se	1338.817(12)	0.0354(19)	0.00136(7)
⁷⁶	Se	231.4270(20)	0.105(3)	0.00403(12)	⁷⁶	Se	1378.172(7)	0.048(4)	0.00184(15)
⁷⁶	Se	238.9980(10)	2.06(3)	0.0791(12)	⁷⁷	Se	1382.159(6)	0.069(3)	0.00265(12)
⁷⁷	Se	248.43(8)	0.023(5)	0.00088(19)	⁷⁶	Se	1384.131(6)	0.080(4)	0.00307(15)
⁷⁶	Se	249.7880(10)	0.538(9)	0.0206(4)	⁷⁶	Se	1395.42(3)	0.024(6)	0.00092(23)
⁷⁶	Se	281.6400(20)	0.124(5)	0.00476(19)	⁷⁶	Se	1402.471(4)	0.032(4)	0.00123(15)
⁷⁴	Se	286.5710(20)	0.280(6)	0.01075(23)	⁷⁶	Se	1411.612(5)	0.115(6)	0.00441(23)
⁷⁴	Se	292.8430(20)	0.0297(21)	0.00114(8)	⁷⁶	Se	1475.746(10)	0.030(20)	0.0012(8)
⁷⁶	Se	297.2160(20)	0.337(7)	0.0129(3)	⁷⁶	Se	1529.27(15)	0.034(6)	0.00130(23)
					⁷⁷	Se	1529.71(5)	0.061(13)	0.0023(5)

^A Z	E _γ -keV	σ _γ ^Z (E _γ)-barns	k ₀	^A Z	E _γ -keV	σ _γ ^Z (E _γ)-barns	k ₀
⁷⁶ Se	1578.621(7)	0.042(4)	0.00161(15)	⁷⁶ Se	4367.73(15)	0.024(3)	0.00092(12)
⁷⁶ Se	1623.124(6)	0.063(5)	0.00242(19)	⁷⁶ Se	4378.36(8)	0.085(16)	0.0033(6)
⁷⁶ Se	1677.06(3)	0.023(4)	0.00088(15)	⁷⁶ Se	4435.83(11)	0.032(7)	0.0012(3)
⁷⁶ Se	1712.75(5)	0.023(3)	0.00088(12)	⁷⁶ Se	4526.75(5)	0.115(8)	0.0044(3)
⁷⁷ Se	1713.544(22)	0.163(8)	0.0063(3)	⁷⁶ Se	4545.72(9)	0.049(5)	0.00188(19)
⁷⁶ Se	1714.739(10)	0.033(3)	0.00127(12)	⁷⁶ Se	4565.56(5)	0.156(11)	0.0060(4)
⁷⁷ Se	1721.43(8)	0.078(4)	0.00299(15)	⁷⁶ Se	4609.57(7)	0.058(9)	0.0022(4)
⁸⁰ Se	1724.88(18)	0.044(5)	0.00169(19)	⁷⁶ Se	4641.97(5)	0.027(6)	0.00104(23)
⁷⁶ Se	1790.24(7)	0.036(4)	0.00138(15)	⁷⁶ Se	4702.43(15)	0.023(4)	0.00088(15)
⁷⁶ Se	1847.93(5)	0.046(4)	0.00177(15)	⁷⁶ Se	4926.78(7)	0.048(8)	0.0018(3)
⁷⁶ Se	1872.21(5)	0.048(4)	0.00184(15)	⁷⁶ Se	4963.217(24)	0.039(5)	0.00150(19)
⁷⁷ Se	1923.32(10)	0.068(5)	0.00261(19)	⁷⁶ Se	5025.80(5)	0.150(12)	0.0058(5)
⁷⁶ Se	1963.15(7)	0.034(4)	0.00130(15)	⁷⁶ Se	5078.75(5)	0.033(11)	0.0013(4)
⁷⁶ Se	1980.40(5)	0.022(16)	0.0008(6)	⁷⁶ Se	5098.56(10)	0.031(8)	0.0012(3)
⁷⁷ Se	1995.871(6)	0.119(5)	0.00457(19)	⁷⁶ Se	5154.33(7)	0.053(5)	0.00203(19)
⁷⁶ Se	2035.26(5)	0.043(5)	0.00165(19)	⁷⁶ Se	5169.734(22)	0.031(4)	0.00119(15)
⁷⁶ Se	2074.08(5)	0.033(20)	0.0013(8)	⁷⁶ Se	5206.60(9)	0.045(5)	0.00173(19)
⁷⁶ Se	2142.65(8)	0.040(4)	0.00154(15)	⁷⁶ Se	5275.98(9)	0.024(9)	0.0009(4)
⁷⁶ Se	2212.02(9)	0.033(3)	0.00127(12)	⁷⁶ Se	5600.995(21)	0.301(14)	0.0116(5)
⁷⁶ Se	2249.88(12)	0.0221(21)	0.00085(8)	⁷⁶ Se	5703.864(23)	0.029(5)	0.00111(19)
⁷⁷ Se	2257.48(13)	0.022(3)	0.00084(12)	⁷⁶ Se	5795.473(21)	0.127(16)	0.0049(6)
⁷⁶ Se	2264.68(17)	0.031(4)	0.00119(15)	⁷⁷ Se	5813.24(10)	0.0269(13)	0.00103(5)
⁷⁷ Se	2284.36(6)	0.054(5)	0.00207(19)	⁷⁶ Se	6006.973(21)	0.289(20)	0.0111(8)
⁷⁷ Se	2319.4(4)	0.025(10)	0.0010(4)	⁷⁶ Se	6016.113(21)	0.101(10)	0.0039(4)
⁷⁷ Se	2391.87(10)	0.043(4)	0.00165(15)	⁷⁷ Se	6049.20(13)	0.0291(13)	0.00112(5)
⁷⁷ Se	2391.89(9)	0.038(7)	0.0015(3)	⁷⁶ Se	6231.597(21)	0.10(4)	0.0038(15)
⁷⁶ Se	2417.59(12)	0.024(17)	0.0009(7)	⁸⁰ Se	6232.9(5)	0.10(3)	0.0038(12)
⁷⁷ Se	2572.70(8)	0.025(4)	0.00096(15)	⁷⁷ Se	6244.07(13)	0.043(3)	0.00165(12)
⁷⁶ Se	2590.77(5)	0.039(13)	0.0015(5)	⁷⁷ Se	6315.30(9)	0.044(3)	0.00169(12)
⁷⁶ Se	2600.85(8)	0.0221(21)	0.00085(8)	⁷⁶ Se	6413.379(21)	0.192(15)	0.0074(6)
⁷⁶ Se	2614.09(5)	0.047(5)	0.00180(19)	⁷⁷ Se	6498.52(12)	0.047(4)	0.00180(15)
⁷⁷ Se	2674.47(6)	0.060(5)	0.00230(19)	⁷⁶ Se	6600.690(21)	0.623(20)	0.0239(8)
⁷⁶ Se	2749.78(15)	0.023(5)	0.00088(19)	⁷⁷ Se	6811.00(13)	0.0257(22)	0.00099(8)
⁷⁷ Se	2769.87(8)	0.035(3)	0.00134(12)	⁷⁷ Se	6905.75(8)	0.0234(22)	0.00090(8)
⁷⁶ Se	2809.08(7)	0.034(24)	0.0013(9)	⁷⁷ Se	7113.76(8)	0.037(3)	0.00142(12)
⁷⁶ Se	2872.93(9)	0.046(3)	0.00177(12)	⁷⁶ Se	7179.492(21)	0.261(25)	0.0100(10)
⁷⁷ Se	2873.47(9)	0.061(8)	0.0023(3)	⁷⁷ Se	7209.15(6)	0.056(3)	0.00215(12)
⁷⁶ Se	2922.68(11)	0.0214(21)	0.00082(8)	⁷⁶ Se	7418.467(21)	0.350(13)	0.0134(5)
⁷⁶ Se	2982.82(11)	0.030(9)	0.0012(4)	⁷⁷ Se	7491.71(9)	0.0295(15)	0.00113(6)
⁷⁶ Se	3039.95(11)	0.038(16)	0.0015(6)	⁷⁴ Se	7734.052(18)	0.13(6)	0.0050(23)
⁷⁷ Se	3072.64(13)	0.0257(17)	0.00099(7)	⁷⁷ Se	8162.11(9)	0.058(3)	0.00223(12)
⁷⁶ Se	3206.54(17)	0.027(14)	0.0010(5)	⁷⁷ Se	8170.00(4)	0.054(4)	0.00207(15)
⁷⁷ Se	3242.39(12)	0.033(7)	0.0013(3)	⁷⁷ Se	8501.35(3)	0.048(3)	0.00184(12)
⁷⁶ Se	3279.09(12)	0.023(4)	0.00088(15)	⁷⁷ Se	9188.52(3)	0.150(8)	0.0058(3)
⁷⁶ Se	3296.55(13)	0.028(4)	0.00107(15)	⁷⁷ Se	9883.35(3)	0.220(22)	0.0084(8)
⁷⁷ Se	3385.13(12)	0.038(11)	0.0015(4)	⁷⁷ Se	10496.99(3)	0.0221(25)	0.00085(10)
⁷⁷ Se	3439.40(13)	0.028(3)	0.00107(12)	Bromine (Z=35), At. Wt.=79.904(1), σ_γ^Z=6.39(7)			
⁷⁶ Se	3466.82(17)	0.022(4)	0.00084(15)	⁸¹ Br	29.1130(10)	0.1680(20)	0.00637(8)
⁷⁶ Se	3517.60(17)	0.032(5)	0.00123(19)	⁷⁹ Br	37.0520(20)d	0.428(12)	0.0162[7.5%]
⁷⁶ Se	3550.31(20)	0.042(17)	0.0016(7)	⁷⁹ Br	37.054(3)	0.160(10)	0.0061(4)
⁷⁶ Se	3620.46(17)	0.028(4)	0.00107(15)	⁷⁹ Br	50.112(3)	0.0081(6)	0.000307(23)
⁷⁶ Se	3636.29(17)	0.030(4)	0.00115(15)	⁷⁹ Br	59.471(4)	0.202(5)	0.00766(19)
⁷⁶ Se	3693.06(20)	0.024(9)	0.0009(4)	⁸¹ Br	72.0210(20)	0.0121(4)	0.000459(15)
⁷⁶ Se	3700.14(12)	0.034(24)	0.0013(9)	⁷⁹ Br	74.972(3)	0.0323(7)	0.00123(3)
⁷⁶ Se	3858.09(11)	0.037(6)	0.00142(23)	⁸¹ Br	85.267(7)	0.0096(4)	0.000364(15)
⁷⁶ Se	3866.33(10)	0.024(5)	0.00092(19)	⁷⁹ Br	124.028(3)	0.0268(5)	0.001016(19)
⁷⁶ Se	3873.00(12)	0.025(4)	0.00096(15)	⁷⁹ Br	126.280(3)	0.0174(4)	0.000660(15)
⁷⁶ Se	3901.06(17)	0.073(8)	0.0028(3)	⁷⁹ Br	146.904(3)	0.0184(7)	0.00070(3)
⁷⁶ Se	3945.94(17)	0.033(5)	0.00127(19)	⁷⁹ Br	159.044(4)	0.0171(7)	0.00065(3)
⁷⁶ Se	3968.30(13)	0.040(4)	0.00154(15)	⁷⁹ Br	159.800(4)	0.0232(7)	0.00088(3)
⁷⁶ Se	4003.78(5)	0.025(4)	0.00096(15)	⁷⁹ Br	175.084(3)	0.0173(12)	0.00066(5)
⁷⁶ Se	4020.78(7)	0.0225(16)	0.00086(6)	⁸¹ Br	184.6440(10)	0.0258(12)	0.00098(5)
⁷⁶ Se	4056.54(11)	0.031(5)	0.00119(19)	⁷⁹ Br	195.602(4)	0.434(14)	0.0165(5)
⁷⁶ Se	4064.52(11)	0.0229(14)	0.00088(5)	⁷⁹ Br	197.607(3)	0.0175(11)	0.00066(4)
⁷⁶ Se	4174.76(12)	0.037(7)	0.0014(3)	⁷⁹ Br	211.594(3)	0.0454(21)	0.00172(8)
⁷⁶ Se	4185.94(13)	0.042(10)	0.0016(4)	⁷⁹ Br	213.816(5)	0.0104(11)	0.00039(4)
⁷⁶ Se	4243.49(13)	0.0220(13)	0.00084(5)	⁷⁹ Br	218.785(4)	0.019(8)	0.0007(3)
⁷⁶ Se	4354.79(9)	0.040(5)	0.00154(19)	⁷⁹ Br	219.377(3)	0.399(14)	0.0151(5)

^A Z	E _γ -keV	σ _γ ^Z (E _γ)-barns	k ₀	^A Z	E _γ -keV	σ _γ ^Z (E _γ)-barns	k ₀
⁸¹ Br	221.0950(20)	0.0123(14)	0.00047(5)	⁸¹ Br	541.856(9)	0.0151(23)	0.00057(9)
⁷⁹ Br	223.627(3)	0.153(5)	0.00580(19)	⁷⁹ Br	542.515(6)	0.114(5)	0.00432(19)
⁷⁹ Br	226.53(5)	0.0080(20)	0.00030(8)	⁷⁹ Br	545.667(7)	0.0094(14)	0.00036(5)
⁷⁹ Br	234.320(3)	0.205(10)	0.0078(4)	⁷⁹ Br	549.559(3)	0.0593(14)	0.00225(5)
⁷⁹ Br	236.454(3)	0.0372(23)	0.00141(9)	⁸¹ Br	552.1730(20)	0.0161(11)	0.00061(4)
⁷⁹ Br	244.237(3)	0.45(3)	0.0171(11)	⁸¹ Br	554.3480(20)d	0.838(8)	0.0318(3)
⁸¹ Br	244.8310(10)	0.15(5)	0.0057(19)	⁷⁹ Br	557.257(21)	0.0315(23)	0.00119(9)
⁷⁹ Br	245.203(4)	0.80(3)	0.0303(11)	⁸¹ Br	566.0990(20)	0.0551(12)	0.00209(5)
⁸¹ Br	245.54(3)	0.018(4)	0.00068(15)	⁸¹ Br	581.2860(20)	0.0231(11)	0.00088(4)
⁸¹ Br	250.2080(20)	0.0145(19)	0.00055(7)	⁸¹ Br	595.2120(20)	0.0177(11)	0.00067(4)
⁷⁹ Br	263.460(8)	0.0105(25)	0.00040(10)	⁸¹ Br	599.27(3)	0.0124(9)	0.00047(3)
⁸¹ Br	264.4350(10)	0.035(3)	0.00133(11)	⁷⁹ Br	604.61(5)	0.013(5)	0.00049(19)
⁷⁹ Br	271.374(3)	0.462(7)	0.0175(3)	⁸¹ Br	608.115(19)	0.0438(13)	0.00166(5)
⁷⁹ Br	274.532(5)	0.158(3)	0.00599(11)	⁷⁹ Br	616.3(5)d	0.39(4)	0.0148[62%]
⁷⁹ Br	278.186(3)	0.0238(14)	0.00090(5)	⁸¹ Br	619.106(4)d	0.515(5)	0.01953(19)
⁸¹ Br	278.3620(20)	0.014(5)	0.00053(19)	⁷⁹ Br	619.17(3)	0.0308(12)	0.00117(5)
⁸¹ Br	287.7390(20)	0.253(4)	0.00960(15)	⁷⁹ Br	630.710(12)	0.0224(13)	0.00085(5)
⁷⁹ Br	294.349(3)	0.1160(22)	0.00440(8)	⁷⁹ Br	636.681(8)	0.018(4)	0.00068(15)
⁷⁹ Br	296.908(4)	0.0307(15)	0.00116(6)	⁸¹ Br	643.291(6)	0.0373(20)	0.00141(8)
⁷⁹ Br	299.886(4)	8.00E-02	3.00E-03	⁷⁹ Br	660.561(4)	0.082(3)	0.00311(11)
⁷⁹ Br	303.02(5)	0.008(3)	0.00030(11)	⁷⁹ Br	678.69(4)	0.0089(19)	0.00034(7)
⁷⁹ Br	311.090(6)	0.0080(12)	0.00030(5)	⁸¹ Br	684.885(3)	0.050(3)	0.00190(11)
⁷⁹ Br	314.982(3)	0.460(9)	0.0174(3)	⁷⁹ Br	684.94(5)	0.0120(20)	0.00046(8)
⁷⁹ Br	315.524(17)	0.030(8)	0.0011(3)	⁷⁹ Br	686.930(5)	0.014(3)	0.00053(11)
⁸¹ Br	315.770(5)	0.022(8)	0.0008(3)	⁸¹ Br	687.02(8)	0.0157(20)	0.00060(8)
⁸¹ Br	316.8510(20)	0.017(5)	0.00064(19)	⁷⁹ Br	689.994(16)	0.083(4)	0.00315(15)
⁷⁹ Br	321.937(8)	0.0262(18)	0.00099(7)	⁸¹ Br	698.374(5)d	0.337(3)	0.01278(12)
⁷⁹ Br	329.551(4)	0.0213(16)	0.00081(6)	⁷⁹ Br	702.025(9)	0.0648(14)	0.00246(5)
⁸¹ Br	339.881(3)	0.0134(14)	0.00051(5)	⁸¹ Br	716.14(8)	0.0420(23)	0.00159(9)
⁷⁹ Br	343.405(3)	0.118(4)	0.00448(15)	⁸¹ Br	717.756(20)	0.0373(8)	0.00141(3)
⁸¹ Br	345.0060(10)	0.154(4)	0.00584(15)	⁷⁹ Br	721.417(12)	0.026(6)	0.00099(23)
⁷⁹ Br	345.580(4)	0.023(4)	0.00087(15)	⁷⁹ Br	723.983(5)	0.019(3)	0.00072(11)
⁸¹ Br	346.986(4)	0.0122(18)	0.00046(7)	⁷⁹ Br	731.147(4)	0.0139(6)	0.000527(23)
⁸¹ Br	350.3830(20)	0.0188(15)	0.00071(6)	⁸¹ Br	746.970(23)	0.0091(14)	0.00035(5)
⁷⁹ Br	366.604(4)	0.233(6)	0.00884(23)	⁷⁹ Br	751.014(10)	0.029(3)	0.00110(11)
⁷⁹ Br	370.530(5)	0.0171(19)	0.00065(7)	⁷⁹ Br	755.728(11)	0.0126(17)	0.00048(6)
⁷⁹ Br	370.531(3)	0.0171(9)	0.00065(3)	⁷⁹ Br	765.957(10)	0.0537(16)	0.00204(6)
⁷⁹ Br	373.44(5)	0.0140(19)	0.00053(7)	⁸¹ Br	776.517(3)d	0.990(10)	0.0375(4)
⁸¹ Br	374.1180(10)	0.011(3)	0.00042(11)	⁷⁹ Br	809.28(3)	0.0084(22)	0.00032(8)
⁷⁹ Br	377.397(14)	0.0100(19)	0.00038(7)	⁸¹ Br	816.578(20)	0.0191(15)	0.00072(6)
⁸¹ Br	379.988(12)	0.0190(11)	0.00072(4)	⁷⁹ Br	827.31(4)	0.015(3)	0.00057(11)
⁷⁹ Br	385.598(11)	0.0232(9)	0.00088(3)	⁸¹ Br	827.828(6)d	0.285(3)	0.01081(11)
⁷⁹ Br	389.189(4)	0.0486(13)	0.00184(5)	⁷⁹ Br	830.856(14)	0.0413(12)	0.00157(5)
⁸¹ Br	397.147(3)	0.0125(18)	0.00047(7)	⁷⁹ Br	845.70(3)	0.0257(21)	0.00097(8)
⁸¹ Br	400.906(20)	0.0234(16)	0.00089(6)	⁷⁹ Br	850.93(4)	0.0082(14)	0.00031(5)
⁸¹ Br	402.743(3)	0.0170(16)	0.00064(6)	⁸¹ Br	856.13(3)	0.0081(11)	0.00031(4)
⁷⁹ Br	408.55(8)	0.0116(20)	0.00044(8)	⁷⁹ Br	860.488(18)	0.0450(19)	0.00171(7)
⁷⁹ Br	409.002(6)	0.0150(20)	0.00057(8)	⁷⁹ Br	876.59(4)	0.0111(7)	0.00042(3)
⁷⁹ Br	414.04(7)	0.0332(17)	0.00126(6)	⁷⁹ Br	883.60(6)	0.0278(10)	0.00105(4)
⁷⁹ Br	432.216(4)	0.0783(14)	0.00297(5)	⁸¹ Br	888.599(20)	0.0224(15)	0.00085(6)
⁷⁹ Br	450.906(5)	0.0170(13)	0.00064(5)	⁷⁹ Br	889.949(11)	0.0128(17)	0.00049(6)
⁷⁹ Br	452.611(5)	0.0679(24)	0.00258(9)	⁸¹ Br	895.87(5)	0.0213(10)	0.00081(4)
⁷⁹ Br	455.830(3)	0.0230(13)	0.00087(5)	⁷⁹ Br	908.97(9)	0.0144(9)	0.00055(3)
⁷⁹ Br	459.775(4)	0.0455(19)	0.00173(7)	⁸¹ Br	910.73(3)	0.0400(12)	0.00152(5)
⁸¹ Br	465.89(3)	0.026(4)	0.00099(15)	⁷⁹ Br	914.574(7)	0.0508(14)	0.00193(5)
⁸¹ Br	466.63(3)	0.008(4)	0.00030(15)	⁷⁹ Br	919.36(5)	0.016(3)	0.00061(11)
⁷⁹ Br	468.980(3)	0.29(3)	0.0110(11)	⁸¹ Br	932.794(25)	0.0216(10)	0.00082(4)
⁷⁹ Br	470.619(16)	0.018(3)	0.00068(11)	⁷⁹ Br	933.823(12)	0.010(3)	0.00038(11)
⁷⁹ Br	479.082(10)	0.018(9)	0.0007(3)	⁷⁹ Br	952.58(9)	0.0182(8)	0.00069(3)
⁷⁹ Br	482.813(21)	0.0120(20)	0.00046(8)	⁸¹ Br	976.508(24)	0.0459(13)	0.00174(5)
⁸¹ Br	483.886(3)	0.042(18)	0.0016(7)	⁷⁹ Br	977.431(12)	0.013(3)	0.00049(11)
⁷⁹ Br	492.884(4)	0.0292(10)	0.00111(4)	⁸¹ Br	1013.03(3)	0.023(3)	0.00087(11)
⁷⁹ Br	494.045(7)	0.009(5)	0.00034(19)	⁷⁹ Br	1022.385(10)	0.0167(14)	0.00063(5)
⁸¹ Br	495.0380(20)	0.0342(14)	0.00130(5)	⁸¹ Br	1034.706(23)	0.0231(9)	0.00088(3)
⁷⁹ Br	498.19(3)	0.0336(13)	0.00127(5)	⁸¹ Br	1036.890(9)	0.0081(7)	0.00031(3)
⁸¹ Br	512.488(20)	0.21(3)	0.0080(11)	⁸¹ Br	1044.002(5)d	0.323(3)	0.01225(12)
⁷⁹ Br	529.247(7)	0.0321(9)	0.00122(3)	⁸¹ Br	1079.99(5)	0.0350(19)	0.00133(7)
⁸¹ Br	538.219(20)	0.0109(10)	0.00041(4)	⁷⁹ Br	1087.46(3)	0.0092(10)	0.00035(4)

^A Z	E _γ -keV	σ _γ ^Z (E _γ)-barns	k ₀	^A Z	E _γ -keV	σ _γ ^Z (E _γ)-barns	k ₀
⁸¹ Br	1133.427(20)	0.0110(15)	0.00042(6)	⁸⁶ Kr	1475.94(17)	2.4(4)E-4	8.7(14)E-6
⁷⁹ Br	1143.370(21)	0.0225(18)	0.00085(7)	⁸³ Kr	1543.27(19)	0.486(17)	0.0176(6)
⁷⁹ Br	1147.96(4)	0.0205(17)	0.00078(6)	⁸³ Kr	1623.20(20)	0.327(15)	0.0118(5)
⁸¹ Br	1157.506(25)	0.0210(17)	0.00080(6)	⁸³ Kr	1656.15(18)	0.28(5)	0.0101(18)
⁷⁹ Br	1175.25(3)	0.0116(11)	0.00044(4)	⁸³ Kr	1682.0(3)	0.212(17)	0.0077(6)
⁷⁹ Br	1190.73(5)	0.0216(10)	0.00082(4)	⁸³ Kr	1741.7(3)	0.437(19)	0.0158(7)
⁸¹ Br	1201.13(3)	0.0185(8)	0.00070(3)	⁸³ Kr	1741.7(3)	0.437(19)	0.0158(7)
⁷⁹ Br	1248.801(12)	0.0527(22)	0.00200(8)	⁸³ Kr	1741.7(3)	0.437(19)	0.0158(7)
⁸¹ Br	1317.473(10)d	0.314(3)	0.01191(12)	⁸³ Kr	1897.79(8)	2.24(3)	0.0810(11)
⁷⁹ Br	1320.19(4)	0.012(5)	0.00046(19)	⁸³ Kr	1979.34(11)	1.070(22)	0.0387(8)
⁷⁹ Br	1321.96(11)	0.0152(14)	0.00058(5)	⁸³ Kr	2160.48(7)	0.577(15)	0.0209(5)
⁸¹ Br	1474.880(10)d	0.1930(20)	0.00732(8)	⁸³ Kr	2200.86(11)	0.241(10)	0.0087(4)
⁸¹ Br	6349.19(4)	0.0168(12)	0.00064(5)	⁸³ Kr	2544.72(19)	0.27(3)	0.0098(11)
⁸¹ Br	6360.18(3)	0.015(5)	0.00057(19)	⁸³ Kr	6281.4(7)	2.70E-01	9.80E-03
⁸¹ Br	6413.36(3)	0.0136(11)	0.00052(4)	⁸³ Kr	6306.8(7)	4.80E-01	1.70E-02
⁸¹ Br	6437.69(5)	0.0328(17)	0.00124(6)	⁸³ Kr	6519.1(7)	8.80E-01	3.20E-02
⁷⁹ Br	6533.28(8)	0.0196(14)	0.00074(5)	⁸³ Kr	6803.5(8)	6.40E-01	2.30E-02
⁷⁹ Br	6570.15(13)	0.0285(13)	0.00108(5)	⁸³ Kr	6880.7(7)	1.30E+00	4.70E-02
⁸¹ Br	6570.27(3)	0.008(3)	0.00030(11)	⁸³ Kr	6931.7(8)	5.40E-01	2.00E-02
⁸¹ Br	6621.81(3)	0.0104(22)	0.00039(8)	⁸³ Kr	7207.5(9)	2.50E-01	9.00E-03
⁷⁹ Br	6643.30(8)	0.0318(18)	0.00121(7)	Rubidium (Z=37), At. Wt.=85.4678(3), σ_γ^Z=0.38(7)			
⁷⁹ Br	6668.16(11)	0.0306(18)	0.00116(7)	⁸⁵ Rb	54.01(6)	0.006(3)	2.1(11)E-4
⁷⁹ Br	6689.13(9)	0.0321(14)	0.00122(5)	⁸⁵ Rb	59.75(6)	0.010(4)	0.00035(14)
⁷⁹ Br	6701.38(9)	0.0168(10)	0.00064(4)	⁸⁵ Rb	84.85(8)	0.0052(22)	1.8(8)E-4
⁸¹ Br	6746.030(22)	0.0386(16)	0.00146(6)	⁸⁵ Rb	96.87(10)	0.0026(9)	9(3)E-5
⁷⁹ Br	6894.78(8)	0.0101(7)	0.00038(3)	⁸⁵ Rb	113.76(4)	0.00535(14)	1.90(5)E-4
⁷⁹ Br	6977.51(8)	0.0110(8)	0.00042(3)	⁸⁵ Rb	119.94(4)	0.00267(9)	9.5(3)E-5
⁷⁹ Br	7031.43(8)	0.0447(22)	0.00170(8)	⁸⁷ Rb	166.01(3)	0.00215(8)	7.6(3)E-5
⁷⁹ Br	7078.18(8)	0.0566(24)	0.00215(9)	⁸⁵ Rb	176.2(9)	0.0031(13)	1.1(5)E-4
⁷⁹ Br	7126.18(8)	0.0154(15)	0.00058(6)	⁸⁷ Rb	196.34(3)	0.00964(19)	0.000342(7)
⁷⁹ Br	7168.08(8)	0.0103(8)	0.00039(3)	⁸⁵ Rb	198.96(10)	0.00266(9)	9.4(3)E-5
⁸¹ Br	7172.612(22)	0.0238(12)	0.00090(5)	⁸⁵ Rb	224.31(6)	0.00132(7)	4.68(25)E-5
⁸¹ Br	7229.873(22)	0.0250(14)	0.00095(5)	⁸⁷ Rb	240.76(3)	0.00224(8)	7.9(3)E-5
⁸¹ Br	7301.888(22)	0.0101(8)	0.00038(3)	⁸⁵ Rb	283.80(8)	0.00092(6)	3.26(21)E-5
⁷⁹ Br	7422.77(8)	0.0495(18)	0.00188(7)	⁸⁵ Rb	316.13(4)	0.00138(8)	4.9(3)E-5
⁷⁹ Br	7511.57(8)	0.0108(9)	0.00041(3)	⁸⁵ Rb	322.80(4)	0.00254(10)	9.0(4)E-5
⁷⁹ Br	7577.04(8)	0.108(3)	0.00410(11)	⁸⁷ Rb	362.62(5)	0.00314(12)	1.11(4)E-4
⁷⁹ Br	7610.73(8)	0.0093(8)	0.00035(3)	⁸⁵ Rb	362.78(9)	0.0061(22)	2.2(8)E-4
Krypton (Z=36), At. Wt.=83.80(1), σ_γ^Z=25.8(12)				⁸⁷ Rb	390.60(4)	0.00179(8)	6.3(3)E-5
⁸² Kr	9.4050(10)d	0.122(24)	0.0044[17%]	⁸⁵ Rb	421.50(3)	0.0259(5)	0.000918(18)
⁸³ Kr	367.7(5)	0.532(10)	0.0192(4)	⁸⁵ Rb	487.89(4)	0.0494(12)	0.00175(4)
⁸³ Kr	419.4(5)	0.630(10)	0.0228(4)	⁸⁵ Rb	514.57(4)	0.00653(20)	2.32(7)E-4
⁸³ Kr	425.30(11)	2.960(19)	0.1070(7)	⁸⁵ Rb	529.9(9)	0.0031(13)	1.1(5)E-4
⁸³ Kr	448.11(11)	0.590(19)	0.0213(7)	⁸⁵ Rb	536.48(4)	0.0167(5)	0.000592(18)
⁸³ Kr	541.50(12)	0.295(12)	0.0107(4)	⁸⁵ Rb	538.66(4)	0.0169(5)	0.000599(18)
⁸³ Kr	546.98(12)	0.328(12)	0.0119(4)	⁸⁵ Rb	555.61(3)d	0.0407(10)	0.00144[98%]
⁸³ Kr	605.5(4)	0.398(25)	0.0144(9)	⁸⁵ Rb	556.82(3)	0.0913(24)	0.00324(9)
⁸³ Kr	612.0(3)	0.42(3)	0.0152(11)	⁸⁵ Rb	565.37(4)	0.00383(10)	1.36(4)E-4
⁸³ Kr	637.13(18)	0.251(22)	0.0091(8)	⁸⁵ Rb	638.93(5)	0.0101(13)	0.00036(5)
⁸³ Kr	708.24(21)	0.220(21)	0.0080(8)	⁸⁵ Rb	640.20(10)	0.0032(7)	1.13(25)E-4
⁸³ Kr	737.0(9)	0.31(6)	0.0112(22)	⁸⁵ Rb	668.76(7)	0.00211(10)	7.5(4)E-5
⁸³ Kr	802.62(8)	1.520(22)	0.0550(8)	⁸⁵ Rb	691.57(5)	0.00725(18)	0.000257(6)
⁸³ Kr	881.74(11)	20.8(3)	0.752(11)	⁸⁵ Rb	726.98(5)	0.00421(15)	1.49(5)E-4
⁸³ Kr	919.79(19)	0.222(17)	0.0080(6)	⁸⁵ Rb	747.67(4)	0.00268(12)	9.5(4)E-5
⁸³ Kr	938.12(13)	0.449(21)	0.0162(8)	⁸⁵ Rb	816.59(6)	0.0031(9)	1.1(3)E-4
⁸³ Kr	943.36(14)	0.713(8)	0.0258(3)	⁸⁷ Rb	834.79(6)	0.00197(13)	7.0(5)E-5
⁸³ Kr	946.5(5)	0.447(19)	0.0162(7)	⁸⁵ Rb	872.94(4)	0.0321(5)	0.001138(18)
⁸³ Kr	963.44(13)	0.660(22)	0.0239(8)	⁸⁵ Rb	881.50(4)	0.00480(17)	1.70(6)E-4
⁸³ Kr	987.69(19)	0.256(25)	0.0093(9)	⁸⁵ Rb	913.12(6)	0.00497(15)	1.76(5)E-4
⁸³ Kr	1016.2(3)	1.08(7)	0.0391(25)	⁸⁵ Rb	944.49(9)	0.0035(13)	1.2(5)E-4
⁸³ Kr	1077.55(25)	0.47(3)	0.0170(11)	⁸⁵ Rb	945.72(7)	0.00390(15)	1.38(5)E-4
⁸³ Kr	1124.44(6)	1.420(21)	0.0514(8)	⁸⁵ Rb	1026.55(6)	0.0218(4)	0.000773(14)
⁸³ Kr	1213.42(12)	8.28(17)	0.299(6)	⁸⁵ Rb	1032.32(5)	0.0227(4)	0.000805(14)
⁸³ Kr	1230.82(11)	0.310(12)	0.0112(4)	⁸⁵ Rb	1076.64(20)d	0.0301(5)	0.001067[<0.1%]
⁸³ Kr	1293.20(13)	0.383(25)	0.0139(9)	⁸⁵ Rb	1105.52(10)	0.0151(3)	0.000535(11)
⁸³ Kr	1331.89(13)	0.39(6)	0.0141(22)	⁸⁷ Rb	1141.49(15)	0.00113(11)	4.0(4)E-5
⁸³ Kr	1443.43(11)	0.237(10)	0.0086(4)	⁸⁵ Rb	1178.86(10)	0.0044(13)	1.6(5)E-4
⁸³ Kr	1463.86(6)	7.10(8)	0.257(3)	⁸⁵ Rb	1219.80(9)	0.00446(21)	1.58(7)E-4
				⁸⁷ Rb	1245.20(6)	0.00253(12)	9.0(4)E-5
				⁸⁵ Rb	1304.48(4)	0.0204(5)	0.000723(18)

^A Z	E _γ -keV	σ _γ ² (E _γ)-barns	k ₀	^A Z	E _γ -keV	σ _γ ² (E _γ)-barns	k ₀
⁸⁵ Rb	1389.32(7)	0.00809(21)	0.000287(7)	⁸⁸ Sr	4078.39(5)	0.0055(9)	1.9(3)E-4
⁸⁵ Rb	1438.31(4)	0.00200(15)	7.1(5)E-5	⁸⁷ Sr	4604.81(6)	0.0169(7)	0.000585(24)
⁸⁵ Rb	1666.74(9)	0.00774(23)	0.000274(8)	⁸⁷ Sr	5161.37(5)	0.0138(6)	0.000477(21)
⁸⁵Rb	1890.7(4)	0.017(4)	0.00060(14)	⁸⁶ Sr	5361.652(25)	0.0104(6)	0.000360(21)
⁸⁵ Rb	2130.59(17)	0.0031(5)	1.10(18)E-4	⁸⁷ Sr	5423.43(8)	0.0146(7)	0.000505(24)
⁸⁵ Rb	2149.4(7)	0.00153(19)	5.4(7)E-5	⁸⁷ Sr	5684.81(4)	0.0131(9)	0.00045(3)
⁸⁵ Rb	2179.33(16)	0.00168(17)	6.0(6)E-5	⁸⁷ Sr	5791.07(4)	0.0196(9)	0.00068(3)
⁸⁵ Rb	2353.43(17)	0.00122(9)	4.3(3)E-5	⁸⁷ Sr	5999.31(5)	0.0109(6)	0.000377(21)
⁸⁷ Rb	2391.86(21)	0.00094(12)	3.3(4)E-5	⁸⁷ Sr	6101.72(4)	0.0477(17)	0.00165(6)
⁸⁵ Rb	2461.41(17)	0.00251(17)	8.9(6)E-5	⁸⁷ Sr	6266.87(4)	0.077(3)	0.00266(10)
⁸⁵ Rb	2476.2(7)	0.0013(4)	4.6(14)E-5	⁸⁷ Sr	6660.40(3)	0.0644(23)	0.00223(8)
⁸⁵ Rb	2568.8(5)	0.0017(4)	6.0(14)E-5	⁸⁷ Sr	6671.58(4)	0.0132(7)	0.000457(24)
⁸⁵ Rb	2585.58(16)	0.00240(18)	8.5(6)E-5	⁸⁷ Sr	6698.39(5)	0.0127(6)	0.000439(21)
⁸⁷ Rb	3690.17(20)	0.00184(18)	6.5(6)E-5	⁸⁷ Sr	6885.14(3)	0.0478(20)	0.00165(7)
⁸⁷ Rb	4640.79(25)	0.00292(19)	1.04(7)E-4	⁸⁷ Sr	6941.93(3)	0.0502(20)	0.00174(7)
⁸⁷ Rb	5220.8(3)	0.00176(18)	6.2(6)E-5	⁸⁷ Sr	7527.490(25)	0.0687(24)	0.00238(8)
⁸⁷ Rb	5886.30(24)	0.00217(17)	7.7(6)E-5	⁸⁶ Sr	8039.250(19)	0.0260(14)	0.00090(5)
⁸⁵ Rb	6065.13(17)	0.0047(3)	1.67(11)E-4	⁸⁷ Sr	8378.069(23)	0.0197(7)	0.000681(24)
⁸⁵ Rb	6081.9(5)	0.00097(16)	3.4(6)E-5	Yttrium (Z=39), At. Wt.=88.90585(2), σ_γ²=1.280(20)			
⁸⁷ Rb	6082.4(4)	0.00097(16)	3.4(6)E-5	⁸⁹ Y	176.923(22)	0.0129(7)	0.000440(24)
⁸⁵ Rb	6143.2(4)	0.00132(19)	4.7(7)E-5	⁸⁹Y	202.53(3)	0.289(7)	0.00985(24)
⁸⁵ Rb	6189.29(18)	0.0036(3)	1.28(11)E-4	⁸⁹ Y	202.53(3)d	0.0018(5)	6.1E-5[10%]
⁸⁵ Rb	6319.4(8)	0.00107(18)	3.8(6)E-5	⁸⁹Y	574.106(20)	0.174(7)	0.00593(24)
⁸⁵ Rb	6351.44(17)	0.00173(16)	6.1(6)E-5	⁸⁹ Y	604.99(3)	0.0084(7)	0.000286(24)
⁸⁵ Rb	6385.11(25)	0.00148(19)	5.2(7)E-5	⁸⁹Y	776.613(18)	0.659(9)	0.0225(3)
⁸⁵ Rb	6471.37(17)	0.0049(3)	1.74(11)E-4	⁸⁹ Y	953.534(21)	0.0135(11)	0.00046(4)
⁸⁵ Rb	6501.3(7)	0.00165(19)	5.9(7)E-5	⁸⁹ Y	1211.573(22)	0.0453(22)	0.00154(8)
⁸⁵ Rb	6520.11(18)	0.0064(4)	2.27(14)E-4	⁸⁹ Y	1214.060(23)	0.0096(12)	0.00033(4)
⁸⁵ Rb	6831.64(10)	0.0064(4)	2.27(14)E-4	⁸⁹ Y	1369.099(23)	0.0087(12)	0.00030(4)
⁸⁵ Rb	6942.98(13)	0.00161(15)	5.7(5)E-5	⁸⁹ Y	1371.124(20)	0.0404(22)	0.00138(8)
⁸⁵ Rb	7212.34(10)	0.00129(17)	4.6(6)E-5	⁸⁹ Y	1416.566(22)	0.0173(13)	0.00059(4)
⁸⁵ Rb	7346.16(10)	0.0059(3)	2.09(11)E-4	⁸⁹ Y	1558.459(23)	0.0163(11)	0.00056(4)
⁸⁵ Rb	7545.10(13)	0.00099(14)	3.5(5)E-5	⁸⁹ Y	1571.604(22)	0.0148(11)	0.00050(4)
⁸⁵Rb	7624.07(11)	0.0114(5)	0.000404(18)	⁸⁹ Y	1640.913(22)	0.0146(15)	0.00050(5)
⁸⁵ Rb	8093.76(10)	0.00211(20)	7.5(7)E-5	⁸⁹ Y	1760.964(23)	0.0086(10)	0.00029(3)
⁸⁵ Rb	8650.52(10)	0.0022(4)	7.8(14)E-5	⁸⁹ Y	1780.70(6)	0.0082(18)	0.00028(6)
Strontium (Z=38), At. Wt.=87.62(1), σ_γ²=1.30(21)				⁸⁹ Y	1815.15(3)	0.0223(15)	0.00076(5)
⁸⁴ Sr	231.68(4)	0.0017(3)	5.9(10)E-5	⁸⁹ Y	2139.11(4)	0.0101(12)	0.00034(4)
⁸⁶ Sr	388.526(22)d	0.0785(23)	0.00272[11%]	⁸⁹ Y	2196.10(3)	0.0107(10)	0.00036(3)
⁸⁷ Sr	434.925(20)	0.0346(8)	0.00120(3)	⁸⁹ Y	2273.38(4)	0.0121(24)	0.00041(8)
⁸⁶ Sr	484.822(14)	0.0315(12)	0.00109(4)	⁸⁹ Y	2327.31(5)	0.0108(18)	0.00037(6)
⁸⁷ Sr	585.613(14)	0.0703(14)	0.00243(5)	⁸⁹ Y	2405.36(4)	0.0095(18)	0.00032(6)
⁸⁷Sr	850.657(12)	0.275(4)	0.00951(14)	⁸⁹ Y	2504.60(4)	0.0139(17)	0.00047(6)
⁸⁷Sr	898.055(11)	0.702(10)	0.0243(4)	⁸⁹ Y	2546.68(3)	0.0219(17)	0.00075(6)
⁸⁷ Sr	934.49(3)	0.024(4)	0.00083(14)	⁸⁹ Y	2589.56(5)	0.0137(15)	0.00047(5)
⁸⁷ Sr	1218.523(16)	0.0599(13)	0.00207(5)	⁸⁹ Y	2749.181(24)	0.0246(19)	0.00084(7)
⁸⁷ Sr	1323.92(6)	0.013(3)	0.00045(10)	⁸⁹ Y	2756.47(5)	0.0103(12)	0.00035(4)
⁸⁷ Sr	1368.677(25)	0.038(8)	0.0013(3)	⁸⁹ Y	2819.38(5)	0.0096(9)	0.00033(3)
⁸⁷ Sr	1382.44(4)	0.0239(8)	0.00083(3)	⁸⁹ Y	2847.23(7)	0.0096(9)	0.00033(3)
⁸⁷ Sr	1407.89(5)	0.0104(20)	0.00036(7)	⁸⁹ Y	2922.48(3)	0.0090(9)	0.00031(3)
⁸⁷ Sr	1436.264(17)	0.0124(6)	0.000429(21)	⁸⁹ Y	3160.17(4)	0.0109(6)	0.000372(20)
⁸⁷ Sr	1493.06(3)	0.0130(8)	0.00045(3)	⁸⁹ Y	3164.64(5)	0.0120(6)	0.000409(20)
⁸⁷ Sr	1534.561(22)	0.0317(9)	0.00110(3)	⁸⁹ Y	3229.29(3)	0.0116(6)	0.000395(20)
⁸⁷ Sr	1565.48(5)	0.0136(12)	0.00047(4)	⁸⁹ Y	3254.87(4)	0.0119(6)	0.000406(20)
⁸⁷ Sr	1565.54(5)	0.027(4)	0.00093(14)	⁸⁹ Y	3282.41(4)	0.0192(10)	0.00065(3)
⁸⁷ Sr	1706.62(4)	0.0231(8)	0.00080(3)	⁸⁹ Y	3301.23(3)	0.0276(18)	0.00094(6)
⁸⁷ Sr	1717.804(23)	0.0674(15)	0.00233(5)	⁸⁹ Y	3380.87(4)	0.0159(8)	0.00054(3)
⁸⁷ Sr	1736.33(7)	0.0140(14)	0.00048(5)	⁸⁹ Y	3544.52(4)	0.0163(10)	0.00056(3)
⁸⁷ Sr	1736.54(3)	0.018(3)	0.00062(10)	⁸⁹ Y	3696.70(4)	0.0138(8)	0.00047(3)
⁸⁷ Sr	1799.06(3)	0.0356(11)	0.00123(4)	⁸⁹ Y	3713.08(4)	0.0078(4)	0.000266(14)
⁸⁷Sr	1836.067(21)	1.030(18)	0.0356(6)	⁸⁹ Y	3870.79(5)	0.0089(5)	0.000303(17)
⁸⁷ Sr	2111.36(3)	0.0279(10)	0.00096(4)	⁸⁹ Y	4009.64(7)	0.0089(6)	0.000303(20)
⁸⁷ Sr	2202.92(3)	0.0341(10)	0.00118(4)	⁸⁹ Y	4098.82(3)	0.0108(6)	0.000368(20)
⁸⁷ Sr	2276.52(3)	0.0431(13)	0.00149(5)	⁸⁹ Y	4107.68(3)	0.067(12)	0.0023(4)
⁸⁷ Sr	2391.09(3)	0.0471(15)	0.00163(5)	⁸⁹ Y	4352.26(4)	0.0207(16)	0.00071(6)
⁸⁷ Sr	2463.52(4)	0.0131(6)	0.000453(21)	⁸⁹ Y	4380.97(4)	0.0085(5)	0.000290(17)
⁸⁷ Sr	2577.85(4)	0.0246(9)	0.00085(3)	⁸⁹ Y	4490.91(3)	0.0093(6)	0.000317(20)
⁸⁷ Sr	3009.39(3)	0.0575(15)	0.00199(5)	⁸⁹ Y	4660.75(3)	0.0088(5)	0.000300(17)

^A Z	E _γ -keV	σ _γ ^Z (E _γ)-barns	k ₀	^A Z	E _γ -keV	σ _γ ^Z (E _γ)-barns	k ₀
⁸⁹ Y	5645.236(25)	0.029(3)	0.00099(10)	⁹¹ Zr	4994.61(18)	0.0027(5)	9.0(17)E-5
⁸⁹Y	6080.171(22)	0.76(4)	0.0259(14)	⁹¹ Zr	5006.56(16)	0.0049(7)	1.63(23)E-4
Zirconium (Z=40), At. Wt.=91.224(2), σ_γ^Z=0.19(3)				⁹⁰ Zr	5150.3(9)	0.0017(12)	6(4)E-5
⁹⁴ Zr	101.17(9)	0.0026(3)	8.6(10)E-5	⁹¹ Zr	5182.73(17)	0.0019(4)	6.3(13)E-5
⁹⁶ Zr	160.94(10)	0.0111(7)	0.000369(23)	⁹¹ Zr	5263.42(17)	0.0064(8)	2.1(3)E-4
⁹² Zr	266.78(16)	0.0091(5)	0.000302(17)	⁹² Zr	5309.9(7)	0.0024(4)	8.0(13)E-5
⁹¹ Zr	273.036(5)	0.0029(4)	9.6(13)E-5	⁹¹ Zr	5372.23(17)	0.0016(4)	5.3(13)E-5
⁹¹ Zr	403.898(13)	0.00137(25)	4.6(8)E-5	⁹⁶ Zr	5574.9(4)	0.0023(4)	7.6(13)E-5
⁹¹ Zr	448.217(5)	0.0067(3)	2.23(10)E-4	⁹¹Zr	6295.13(16)	0.0279(20)	0.00093(7)
⁹¹ Zr	492.398(8)	0.0027(3)	9.0(10)E-5	⁹⁴ Zr	6357.8(4)	0.0026(4)	8.6(13)E-5
⁹¹Zr	560.958(3)	0.0285(5)	0.000947(17)	Niobium (Z=41), At. Wt.=92.90638(2), σ_γ^Z=1.15(5)			
⁹⁴ Zr	569.5(3)	0.0013(3)	4.3(10)E-5	⁹³Nb	17.810(7)	0.0579(14)	0.00189(5)
⁹¹ Zr	571.171(5)	0.0022(3)	7.3(10)E-5	⁹³ Nb	54.704(7)	0.0058(7)	1.89(23)E-4
⁹⁰ Zr	652.8(4)	0.0029(14)	1.0(5)E-4	⁹³ Nb	78.6680(10)	0.0169(3)	0.000551(10)
⁹⁶ Zr	743.36(3)d	0.00101(6)	3.36E-5[2.0%]	⁹³Nb	99.4070(10)	0.196(9)	0.0064(3)
⁹¹ Zr	844.206(4)	0.0095(4)	0.000316(13)	⁹³Nb	113.4010(10)	0.117(3)	0.00382(10)
⁹¹ Zr	902.861(8)	0.0047(5)	1.56(17)E-4	⁹³ Nb	135.47(6)	0.0029(9)	9(3)E-5
⁹¹ Zr	912.766(7)	0.0117(5)	0.000389(17)	⁹³ Nb	136.21(12)	0.0027(7)	8.8(23)E-5
⁹¹Zr	934.4640(10)	0.125(5)	0.00415(17)	⁹³ Nb	138.614(8)	0.0089(19)	0.00029(6)
⁹⁴ Zr	939.11(10)	0.0017(5)	5.6(17)E-5	⁹³ Nb	140.10(3)	0.00226(21)	7.4(7)E-5
⁹² Zr	946.6(5)	0.0020(5)	6.6(17)E-5	⁹³ Nb	150.711(22)	0.00201(21)	6.6(7)E-5
⁹⁴ Zr	953.77(15)	0.0030(5)	9.97(17)E-5	⁹³ Nb	161.2610(20)	0.0190(5)	0.000620(16)
⁹¹ Zr	972.332(10)	0.0025(17)	8(6)E-5	⁹³ Nb	193.96(13)	0.0022(4)	7.2(13)E-5
⁹¹ Zr	990.540(7)	0.0029(5)	9.6(17)E-5	⁹³Nb	253.115(5)	0.1320(19)	0.00431(6)
⁹⁴ Zr	1030.83(24)	0.0013(4)	4.3(13)E-5	⁹³Nb	255.9290(20)	0.176(3)	0.00574(10)
⁹⁴ Zr	1054.75(16)	0.0037(5)	1.23(17)E-4	⁹³ Nb	270.45(4)	0.0046(3)	1.50(10)E-4
⁹⁰ Zr	1067.5(7)	0.0017(8)	6(3)E-5	⁹³Nb	293.206(4)	0.0651(16)	0.00212(5)
⁹⁶Zr	1102.67(6)	0.0235(8)	0.00078(3)	⁹³Nb	309.915(8)	0.0690(17)	0.00225(6)
⁹¹ Zr	1132.126(4)	0.0100(7)	0.000332(23)	⁹³ Nb	319.703(14)	0.00320(23)	1.04(8)E-4
⁹⁴ Zr	1198.25(19)	0.0042(5)	1.40(17)E-4	⁹³ Nb	329.178(12)	0.0108(4)	0.000352(13)
⁹⁰Zr	1205.6(7)	0.042(5)	0.00140(17)	⁹³ Nb	329.185(10)	0.0080(9)	0.00026(3)
⁹¹ Zr	1222.44(4)	0.0018(4)	6.0(13)E-5	⁹³Nb	337.527(7)	0.054(6)	0.00176(20)
⁹¹ Zr	1248.100(12)	0.0038(4)	1.26(13)E-4	⁹³ Nb	338.661(19)	0.0080(19)	0.00026(6)
⁹⁴ Zr	1300.1(5)	0.0015(5)	5.0(17)E-5	⁹³ Nb	355.3360(20)	0.0056(3)	1.83(10)E-4
⁹⁴ Zr	1323.20(25)	0.0025(5)	8.3(17)E-5	⁹³ Nb	450.98(9)	0.00238(20)	7.8(7)E-5
⁹¹Zr	1405.159(3)	0.0301(10)	0.00100(3)	⁹³ Nb	454.60(5)	0.00328(22)	1.07(7)E-4
⁹² Zr	1425.2(4)	0.00287(20)	9.5(7)E-5	⁹³ Nb	456.20(10)	0.0058(7)	1.89(23)E-4
⁹¹ Zr	1463.814(8)	0.0017(7)	5.6(23)E-5	⁹³Nb	458.467(10)	0.0240(5)	0.000783(16)
⁹⁰Zr	1465.7(7)	0.063(15)	0.0021(5)	⁹³ Nb	482.72(3)	0.0032(5)	1.04(16)E-4
⁹² Zr	1650.1(5)	0.0029(12)	1.0(4)E-4	⁹³ Nb	484.14(5)	0.0073(6)	2.38(20)E-4
⁹¹ Zr	1847.220(7)	0.0084(8)	0.00028(3)	⁹³Nb	499.426(8)	0.0648(18)	0.00211(6)
⁹⁰Zr	1880.4(4)	0.016(4)	0.00053(13)	⁹³Nb	518.113(12)	0.0579(13)	0.00189(4)
⁹⁴ Zr	1892.9(4)	0.0034(7)	1.13(23)E-4	⁹³ Nb	525.81(3)	0.0074(6)	2.41(20)E-4
⁹² Zr	1917.2(9)	0.0017(8)	6(3)E-5	⁹³ Nb	527.595(9)	0.0127(7)	0.000414(23)
⁹¹ Zr	1956.66(4)	0.0035(5)	1.16(17)E-4	⁹³ Nb	547.73(7)	0.0045(4)	1.47(13)E-4
⁹¹ Zr	1974.91(4)	0.0024(5)	8.0(17)E-5	⁹³Nb	562.328(9)	0.0293(11)	0.00096(4)
⁹¹ Zr	1988.71(3)	0.0049(5)	1.63(17)E-4	⁹³ Nb	573.07(4)	0.0020(3)	6.5(10)E-5
⁹⁰Zr	2042.2(4)	0.032(8)	0.0011(3)	⁹³ Nb	583.837(11)	0.0022(3)	7.2(10)E-5
⁹¹ Zr	2105.16(5)	0.0025(5)	8.3(17)E-5	⁹³ Nb	590.627(14)	0.0086(5)	0.000281(16)
⁹¹ Zr	2132.84(3)	0.0014(3)	4.7(10)E-5	⁹³ Nb	600.43(3)	0.0035(5)	1.14(16)E-4
⁹² Zr	2190.2(5)	0.0044(5)	1.46(17)E-4	⁹³ Nb	635.80(5)	0.0059(5)	1.92(16)E-4
⁹¹ Zr	2328.10(4)	0.0019(8)	6(3)E-5	⁹³ Nb	636.081(16)	0.0043(5)	1.40(16)E-4
⁹¹ Zr	2436.92(3)	0.0015(7)	5.0(23)E-5	⁹³ Nb	640.995(9)	0.0048(5)	1.57(16)E-4
⁹⁰ Zr	2533.2(5)	0.0037(14)	1.2(5)E-4	⁹³ Nb	642.62(4)	0.0069(5)	2.25(16)E-4
⁹¹ Zr	2537.17(19)	0.0014(5)	4.7(17)E-5	⁹³ Nb	645.40(5)	0.0022(7)	7.2(23)E-5
⁹⁰Zr	2557.8(8)	0.016(4)	0.00053(13)	⁹³ Nb	672.30(5)	0.0023(4)	7.5(13)E-5
⁹⁰Zr	2577.3(14)	0.016(4)	0.00053(13)	⁹³ Nb	689.79(5)	0.0164(6)	0.000535(20)
⁹⁰ Zr	2640.1(8)	0.0105(25)	0.00035(8)	⁹³ Nb	693.74(4)	0.0085(4)	0.000277(13)
⁹¹ Zr	2693.79(3)	0.006(3)	2.0(10)E-4	⁹³ Nb	711.47(4)	0.0024(3)	7.8(10)E-5
⁹¹ Zr	2705.74(9)	0.0019(8)	6(3)E-5	⁹³ Nb	748.71(11)	0.0028(4)	9.1(13)E-5
⁹⁰ Zr	3082.6(12)	0.0096(25)	0.00032(8)	⁹³ Nb	751.671(11)	0.0143(6)	0.000466(20)
⁹¹ Zr	3371.36(3)	0.0020(5)	6.6(17)E-5	⁹³ Nb	755.354(8)	0.0123(6)	0.000401(20)
⁹² Zr	3459.4(15)	0.00137(17)	4.6(6)E-5	⁹³ Nb	775.93(3)	0.0158(6)	0.000515(20)
⁹⁰Zr	3475.8(15)	0.019(5)	0.00063(17)	⁹³ Nb	782.247(11)	0.0042(6)	1.37(20)E-4
⁹¹ Zr	3830.13(8)	0.0017(5)	5.6(17)E-5	⁹³ Nb	783.02(7)	0.0065(5)	2.12(16)E-4
⁹⁰Zr	3982.3(15)	0.015(4)	0.00050(13)	⁹³ Nb	801.91(18)	0.0020(4)	6.5(13)E-5
⁹⁴ Zr	4104.3(3)	0.0029(5)	9.6(17)E-5	⁹³ Nb	812.64(7)	0.0084(5)	0.000274(16)
⁹² Zr	4278.1(7)	0.00147(10)	4.9(3)E-5	⁹³Nb	835.72(3)	0.0376(8)	0.00123(3)

A	Z	E_{γ} -keV	$\sigma_{\gamma}^Z(E_{\gamma})$ -barns	k_0	A	Z	E_{γ} -keV	$\sigma_{\gamma}^Z(E_{\gamma})$ -barns	k_0
⁹³ Nb		850.93(5)	0.0025(5)	8.2(16)E-5	⁹³ Nb		3194.65(19)	0.0021(5)	6.8(16)E-5
⁹³ Nb		853.98(3)	0.0028(5)	9.1(16)E-5	⁹³ Nb		3241.04(12)	0.0026(3)	8.5(10)E-5
⁹³ Nb		871.06d	0.00390(8)	1.27E-4[85%]	⁹³ Nb		3260.34(12)	0.0041(5)	1.34(16)E-4
⁹³ Nb		876.64(11)	0.0077(5)	0.000251(16)	⁹³ Nb		3266.45(12)	0.0042(5)	1.37(16)E-4
⁹³ Nb		878.61(5)	0.0191(17)	0.00062(6)	⁹³ Nb		3267.12(20)	0.0021(6)	6.8(20)E-5
⁹³ Nb		883.42(5)	0.0192(7)	0.000626(23)	⁹³ Nb		3319.93(12)	0.0028(6)	9.1(20)E-5
⁹³ Nb		894.45(11)	0.0185(7)	0.000603(23)	⁹³ Nb		3343.94(12)	0.0023(6)	7.5(20)E-5
⁹³ Nb		898.58(5)	0.0144(7)	0.000470(23)	⁹³ Nb		3353.64(12)	0.0028(6)	9.1(20)E-5
⁹³ Nb		911.476(15)	0.0176(7)	0.000574(23)	⁹³ Nb		3361.64(12)	0.0027(3)	8.8(10)E-5
⁹³ Nb		932.65(3)	0.0020(4)	6.5(13)E-5	⁹³ Nb		3367.05(12)	0.0020(6)	6.5(20)E-5
⁹³ Nb		944.61(4)	0.0056(4)	1.83(13)E-4	⁹³ Nb		3383.54(12)	0.0022(6)	7.2(20)E-5
⁹³Nb		957.28(5)	0.0248(7)	0.000809(23)	⁹³ Nb		3388.53(12)	0.0034(6)	1.11(20)E-4
⁹³ Nb		976.71(4)	0.0021(5)	6.8(16)E-5	⁹³ Nb		3428.34(12)	0.0020(3)	6.5(10)E-5
⁹³ Nb		1001.82(11)	0.0037(5)	1.21(16)E-4	⁹³ Nb		3430.66(20)	0.0031(6)	1.01(20)E-4
⁹³ Nb		1100.05(5)	0.0067(6)	2.19(20)E-4	⁹³ Nb		3431.74(12)	0.0030(4)	9.8(13)E-5
⁹³ Nb		1106.86(5)	0.0076(7)	2.48(23)E-4	⁹³ Nb		3458.34(12)	0.0030(6)	9.8(20)E-5
⁹³ Nb		1117.85(5)	0.0080(11)	0.00026(4)	⁹³ Nb		3465.55(14)	0.0025(3)	8.2(10)E-5
⁹³Nb		1118.54(3)	0.022(7)	0.00072(23)	⁹³ Nb		3502.64(12)	0.0022(3)	7.2(10)E-5
⁹³ Nb		1120.54(7)	0.0062(8)	2.0(3)E-4	⁹³ Nb		3508.04(12)	0.0041(5)	1.34(16)E-4
⁹³ Nb		1122.55(7)	0.0106(13)	0.00035(4)	⁹³ Nb		3538.94(12)	0.00198(22)	6.5(7)E-5
⁹³ Nb		1128.97(6)	0.0175(15)	0.00057(5)	⁹³ Nb		3543.43(12)	0.0021(6)	6.8(20)E-5
⁹³ Nb		1151.47(7)	0.0071(6)	2.32(20)E-4	⁹³ Nb		3561.54(12)	0.0027(3)	8.8(10)E-5
⁹³ Nb		1159.61(10)	0.0066(6)	2.15(20)E-4	⁹³ Nb		3634.02(12)	0.0027(5)	8.8(16)E-5
⁹³ Nb		1188.45(5)	0.0074(6)	2.41(20)E-4	⁹³ Nb		3646.03(12)	0.0022(3)	7.2(10)E-5
⁹³ Nb		1191.06(3)	0.0137(7)	0.000447(23)	⁹³ Nb		3651.22(12)	0.0023(5)	7.5(16)E-5
⁹³Nb		1206.26(5)	0.0284(10)	0.00093(3)	⁹³ Nb		3658.53(12)	0.0023(3)	7.5(10)E-5
⁹³ Nb		1214.31(10)	0.0073(7)	2.38(23)E-4	⁹³ Nb		3676.62(12)	0.0028(6)	9.1(20)E-5
⁹³ Nb		1216.09(9)	0.0021(5)	6.8(16)E-5	⁹³ Nb		3680.54(12)	0.0028(3)	9.1(10)E-5
⁹³ Nb		1219.01(7)	0.0050(6)	1.63(20)E-4	⁹³ Nb		3720.63(12)	0.0033(6)	1.08(20)E-4
⁹³ Nb		1222.41(9)	0.0121(7)	0.000395(23)	⁹³ Nb		3740.94(12)	0.0021(3)	6.8(10)E-5
⁹³ Nb		1227.8(4)	0.0114(7)	0.000372(23)	⁹³ Nb		3745.55(14)	0.0033(4)	1.08(13)E-4
⁹³ Nb		1230.13(7)	0.0051(7)	1.66(23)E-4	⁹³ Nb		3760.94(12)	0.00200(22)	6.5(7)E-5
⁹³ Nb		1240.22(9)	0.0096(7)	0.000313(23)	⁹³ Nb		3773.94(12)	0.0045(5)	1.47(16)E-4
⁹³ Nb		1256.97(9)	0.0059(8)	1.9(3)E-4	⁹³ Nb		3837.12(12)	0.0020(5)	6.5(16)E-5
⁹³ Nb		1258.90(8)	0.0039(8)	1.3(3)E-4	⁹³ Nb		3867.53(12)	0.0026(3)	8.5(10)E-5
⁹³ Nb		1264.5(7)	0.0021(5)	6.8(16)E-5	⁹³ Nb		3879.13(12)	0.0048(6)	1.57(20)E-4
⁹³ Nb		1273.72(7)	0.0052(12)	1.7(4)E-4	⁹³ Nb		3888.74(12)	0.0051(6)	1.66(20)E-4
⁹³ Nb		1291.52(7)	0.0097(7)	0.000316(23)	⁹³ Nb		3892.83(12)	0.0039(5)	1.27(16)E-4
⁹³ Nb		1308.1(4)	0.0068(13)	2.2(4)E-4	⁹³ Nb		3907.03(12)	0.00207(23)	6.8(8)E-5
⁹³ Nb		1361.66(19)	0.0043(5)	1.40(16)E-4	⁹³ Nb		3912.73(12)	0.0022(3)	7.2(10)E-5
⁹³ Nb		1392.73(7)	0.0105(8)	0.00034(3)	⁹³ Nb		3919.65(12)	0.0038(7)	1.24(23)E-4
⁹³ Nb		1394.0(4)	0.0058(13)	1.9(4)E-4	⁹³ Nb		3927.83(12)	0.0026(3)	8.5(10)E-5
⁹³ Nb		1419.39(11)	0.0048(6)	1.57(20)E-4	⁹³ Nb		3931.73(12)	0.0024(3)	7.8(10)E-5
⁹³ Nb		1440.05(9)	0.0068(15)	2.2(5)E-4	⁹³ Nb		3936.72(12)	0.0033(7)	1.08(23)E-4
⁹³ Nb		1442.0(4)	0.0061(6)	1.99(20)E-4	⁹³ Nb		3972.03(12)	0.0030(4)	9.8(13)E-5
⁹³ Nb		1459.6(7)	0.0095(6)	0.000310(20)	⁹³ Nb		3978.62(12)	0.0024(3)	7.8(10)E-5
⁹³ Nb		1460.02(9)	0.0097(22)	0.00032(7)	⁹³ Nb		4000.22(12)	0.0033(4)	1.08(13)E-4
⁹³ Nb		1478.58(14)	0.0029(6)	9.5(20)E-5	⁹³ Nb		4010.72(12)	0.0033(4)	1.08(13)E-4
⁹³ Nb		1481.19(13)	0.0039(8)	1.3(3)E-4	⁹³ Nb		4015.91(12)	0.0055(7)	1.79(23)E-4
⁹³ Nb		1487.9(4)	0.0039(8)	1.3(3)E-4	⁹³ Nb		4090.53(12)	0.0021(4)	6.8(13)E-5
⁹³ Nb		1492.55(24)	0.0022(5)	7.2(16)E-5	⁹³ Nb		4109.13(12)	0.0027(3)	8.8(10)E-5
⁹³ Nb		1614.72(8)	0.0028(5)	9.1(16)E-5	⁹³ Nb		4115.32(12)	0.0026(3)	8.5(10)E-5
⁹³ Nb		1620.12(8)	0.0022(5)	7.2(16)E-5	⁹³ Nb		4130.33(12)	0.0063(7)	2.05(23)E-4
⁹³ Nb		1678.05(17)	0.0033(5)	1.08(16)E-4	⁹³ Nb		4143.52(12)	0.0021(3)	6.8(10)E-5
⁹³ Nb		1716.16(8)	0.0034(5)	1.11(16)E-4	⁹³ Nb		4153.82(12)	0.0028(6)	9.1(20)E-5
⁹³ Nb		1763.20(10)	0.0034(5)	1.11(16)E-4	⁹³ Nb		4191.06(12)	0.00196(21)	6.4(7)E-5
⁹³ Nb		1863.63(8)	0.0028(6)	9.1(20)E-5	⁹³ Nb		4196.68(11)	0.0027(6)	8.8(20)E-5
⁹³ Nb		1878.88(8)	0.0081(7)	0.000264(23)	⁹³ Nb		4208.36(11)	0.0029(6)	9.5(20)E-5
⁹³ Nb		1881.96(10)	0.0036(7)	1.17(23)E-4	⁹³ Nb		4237.17(13)	0.0020(5)	6.5(16)E-5
⁹³ Nb		1919.51(8)	0.0024(4)	7.8(13)E-5	⁹³ Nb		4260.84(12)	0.0036(6)	1.17(20)E-4
⁹³ Nb		1974.93(9)	0.0052(6)	1.70(20)E-4	⁹³ Nb		4304.78(12)	0.0049(8)	1.6(3)E-4
⁹³ Nb		2001.4(3)	0.0025(6)	8.2(20)E-5	⁹³ Nb		4314.26(12)	0.0022(6)	7.2(20)E-5
⁹³ Nb		2019.49(9)	0.0021(5)	6.8(16)E-5	⁹³ Nb		4327.32(11)	0.0027(3)	8.8(10)E-5
⁹³ Nb		2285.80(21)	0.0026(5)	8.5(16)E-5	⁹³ Nb		4330.80(12)	0.0043(7)	1.40(23)E-4
⁹³ Nb		2313.81(9)	0.0046(8)	1.5(3)E-4	⁹³ Nb		4347.62(11)	0.0027(7)	8.8(23)E-5
⁹³ Nb		2319.95(12)	0.0022(9)	7(3)E-5	⁹³ Nb		4384.27(11)	0.0029(3)	9.5(10)E-5
⁹³ Nb		2896.68(12)	0.0025(5)	8.2(16)E-5	⁹³ Nb		4389.04(11)	0.00196(21)	6.4(7)E-5
⁹³ Nb		2922.70(12)	0.0021(6)	6.8(20)E-5	⁹³ Nb		4395.07(9)	0.0044(12)	1.4(4)E-4

^A Z	E _γ -keV	σ _γ ^Z (E _γ)-barns	k ₀	^A Z	E _γ -keV	σ _γ ^Z (E _γ)-barns	k ₀
⁹³ Nb	4431.97(9)	0.0043(9)	1.4(3)E-4	⁹³ Nb	5964.58(7)	0.0055(6)	1.79(20)E-4
⁹³ Nb	4455.30(10)	0.0027(3)	8.8(10)E-5	⁹³ Nb	5980.27(5)	0.0029(5)	9.5(16)E-5
⁹³ Nb	4459.03(11)	0.0030(6)	9.8(20)E-5	⁹³ Nb	5995.47(3)	0.0033(5)	1.08(16)E-4
⁹³ Nb	4466.50(10)	0.0028(3)	9.1(10)E-5	⁹³ Nb	6068.67(5)	0.0026(4)	8.5(13)E-5
⁹³ Nb	4470.69(11)	0.0033(7)	1.08(23)E-4	⁹³ Nb	6292.06(11)	0.0033(4)	1.08(13)E-4
⁹³ Nb	4501.43(10)	0.0056(7)	1.83(23)E-4	⁹³ Nb	6331.751(16)	0.0029(4)	9.5(13)E-5
⁹³ Nb	4505.78(10)	0.0029(3)	9.5(10)E-5	⁹³ Nb	6434.833(18)	0.0047(4)	1.53(13)E-4
⁹³ Nb	4524.10(9)	0.0038(6)	1.24(20)E-4	⁹³ Nb	6595.867(18)	0.0020(3)	6.5(10)E-5
⁹³ Nb	4538.64(9)	0.0058(7)	1.89(23)E-4	⁹³ Nb	6831.141(14)	0.0175(8)	0.00057(3)
⁹³ Nb	4553.99(10)	0.0033(4)	1.08(13)E-4	⁹³ Nb	6915.546(15)	0.0024(3)	7.8(10)E-5
⁹³ Nb	4558.53(11)	0.0049(7)	1.60(23)E-4	⁹³ Nb	7186.449(14)	0.0089(6)	0.000290(20)
⁹³ Nb	4594.44(9)	0.0047(7)	1.53(23)E-4	Molybdenum (Z=42), At. Wt.=95.94(1), σ_γ^Z=2.51(6)			
⁹³ Nb	4606.89(13)	0.0046(6)	1.50(20)E-4	⁹⁸ Mo	140.5110(10)d	0.0276(7)	0.000872[<0.1%]
⁹³ Nb	4629.91(9)	0.0049(7)	1.60(23)E-4	¹⁰⁰ Mo	180.711(15)	0.0017(4)	5.4(13)E-5
⁹³ Nb	4635.44(9)	0.0047(6)	1.53(20)E-4	⁹⁸ Mo	198.38(11)	0.0108(9)	0.00034(3)
⁹³ Nb	4662.32(9)	0.0028(6)	9.1(20)E-5	⁹⁴ Mo	204.20(5)	0.0117(6)	0.000370(19)
⁹³ Nb	4672.16(9)	0.0065(7)	2.12(23)E-4	⁹⁵ Mo	349.77(4)	0.0327(13)	0.00103(4)
⁹³ Nb	4681.99(9)	0.0059(7)	1.92(23)E-4	⁹⁵ Mo	369.68(9)	0.0319(19)	0.00101(6)
⁹³ Nb	4711.67(10)	0.0052(7)	1.70(23)E-4	⁹⁵ Mo	480.57(3)	0.028(5)	0.00088(16)
⁹³ Nb	4739.00(8)	0.0153(9)	0.00050(3)	⁹⁶ Mo	480.97(13)	0.0604(23)	0.00191(7)
⁹³ Nb	4749.12(9)	0.0038(6)	1.24(20)E-4	⁹⁵ Mo	568.88(3)	0.0280(11)	0.00088(4)
⁹³ Nb	4756.28(9)	0.0039(6)	1.27(20)E-4	⁹⁵ Mo	591.21(3)	0.0315(14)	0.00100(4)
⁹³ Nb	4772.35(8)	0.0045(7)	1.47(23)E-4	⁹⁵ Mo	608.744(14)	0.121(4)	0.00382(13)
⁹³ Nb	4791.62(13)	0.0071(7)	2.32(23)E-4	⁹⁵ Mo	719.528(14)	0.310(10)	0.0098(3)
⁹³ Nb	4828.2(4)	0.0057(6)	1.86(20)E-4	⁹⁵ Mo	721.54(4)	0.025(3)	0.00079(10)
⁹³ Nb	4913.65(9)	0.0078(7)	0.000254(23)	⁹⁷ Mo	723.338(19)	0.051(11)	0.0016(4)
⁹³ Nb	4927.94(8)	0.0027(6)	8.8(20)E-5	⁹⁵ Mo	736.820(14)	0.119(4)	0.00376(13)
⁹³ Nb	4942.7(4)	0.0029(3)	9.5(10)E-5	⁹⁵ Mo	778.221(10)	2.02(6)	0.0638(19)
⁹³ Nb	4949.70(10)	0.0051(7)	1.66(23)E-4	⁹⁷ Mo	787.39(3)	0.168(6)	0.00531(19)
⁹³ Nb	4982.53(9)	0.0078(7)	0.000254(23)	⁹⁵ Mo	812.26(5)	0.0264(15)	0.00083(5)
⁹³ Nb	4997.97(8)	0.0033(6)	1.08(20)E-4	⁹⁵ Mo	847.603(11)	0.324(9)	0.0102(3)
⁹³ Nb	5032.08(8)	0.0058(7)	1.89(23)E-4	⁹⁵ Mo	849.85(3)	0.43(3)	0.0136(10)
⁹³ Nb	5052.89(9)	0.0022(5)	7.2(16)E-5	⁹⁵ Mo	852.93(3)	0.0444(17)	0.00140(5)
⁹³ Nb	5065.65(8)	0.0034(6)	1.11(20)E-4	⁹² Mo	943.6(3)	0.0075(9)	2.4(3)E-4
⁹³ Nb	5070.27(7)	0.0102(8)	0.00033(3)	⁹⁵ Mo	968.46(5)	0.0323(19)	0.00102(6)
⁹³ Nb	5087.36(8)	0.0030(5)	9.8(16)E-5	⁹⁵ Mo	1091.289(20)	0.201(6)	0.00635(19)
⁹³ Nb	5103.34(7)	0.0232(12)	0.00076(4)	⁹⁵ Mo	1106.36(4)	0.0309(18)	0.00098(6)
⁹³ Nb	5129.16(8)	0.0034(5)	1.11(16)E-4	⁹⁵ Mo	1190.28(6)	0.0240(14)	0.00076(4)
⁹³ Nb	5179.99(7)	0.0072(7)	2.35(23)E-4	⁹⁵ Mo	1200.10(3)	0.124(4)	0.00392(13)
⁹³ Nb	5193.62(18)	0.0114(8)	0.00037(3)	⁹⁷ Mo	1230.13(5)	0.0253(15)	0.00080(5)
⁹³ Nb	5207.96(9)	0.0072(7)	2.35(23)E-4	⁹⁵ Mo	1317.35(8)	0.091(6)	0.00287(19)
⁹³ Nb	5213.75(9)	0.00196(21)	6.4(7)E-5	⁹⁵ Mo	1497.742(17)	0.122(4)	0.00385(13)
⁹³ Nb	5252.52(9)	0.0080(8)	0.00026(3)	⁹⁵ Mo	1625.817(15)	0.0264(15)	0.00083(5)
⁹³ Nb	5257.70(9)	0.00214(23)	7.0(8)E-5	⁹⁵ Mo	1702.78(4)	0.0220(15)	0.00069(5)
⁹³ Nb	5284.14(8)	0.0050(7)	1.63(23)E-4	⁹⁵ Mo	1846.26(15)	0.022(3)	0.00069(10)
⁹³ Nb	5290.46(8)	0.0022(3)	7.2(10)E-5	⁹⁵ Mo	1923.47(13)	0.0250(18)	0.00079(6)
⁹³ Nb	5301.22(8)	0.0031(6)	1.01(20)E-4	⁹⁵ Mo	2011.87(5)	0.0226(16)	0.00071(5)
⁹³ Nb	5307.94(8)	0.0063(7)	2.05(23)E-4	⁹⁵ Mo	2663.47(9)	0.0455(21)	0.00144(7)
⁹³ Nb	5348.57(8)	0.0082(7)	0.000267(23)	⁹⁵ Mo	5602.15(15)	0.0242(17)	0.00076(5)
⁹³ Nb	5363.82(8)	0.0073(7)	2.38(23)E-4	⁹⁵ Mo	5711.98(12)	0.048(4)	0.00152(13)
⁹³ Nb	5368.1(4)	0.0039(6)	1.27(20)E-4	⁹⁵ Mo	6363.55(10)	0.0235(17)	0.00074(5)
⁹³ Nb	5399.86(7)	0.0050(7)	1.63(23)E-4	⁹⁷ Mo	6624.801(20)	0.027(10)	0.0009(3)
⁹³ Nb	5447.70(7)	0.0026(3)	8.5(10)E-5	⁹⁵ Mo	6919.05(9)	0.106(6)	0.00335(19)
⁹³ Nb	5450.96(7)	0.0053(7)	1.73(23)E-4	⁹⁵ Mo	7527.75(9)	0.0264(20)	0.00083(6)
⁹³ Nb	5496.24(10)	0.0205(14)	0.00067(5)	Ruthenium (Z=44), At. Wt.=101.07(2), σ_γ^Z=2.75(21)			
⁹³ Nb	5507.79(7)	0.0041(5)	1.34(16)E-4	¹⁰⁴ Ru	75.251(25)	0.0233(22)	0.00070(7)
⁹³ Nb	5511.28(8)	0.0053(7)	1.73(23)E-4	⁹⁸ Ru	89.69(10)	0.0036(7)	1.08(21)E-4
⁹³ Nb	5532.16(8)	0.0027(5)	8.8(16)E-5	¹⁰⁴ Ru	107.917(14)	0.0153(14)	0.00046(4)
⁹³ Nb	5572.33(8)	0.0037(5)	1.21(16)E-4	¹⁰⁰ Ru	127.18(8)	0.049(4)	0.00147(12)
⁹³ Nb	5591.31(6)	0.0080(7)	0.000261(23)	¹⁰² Ru	136.05(4)	0.066(6)	0.00198(18)
⁹³ Nb	5607.32(8)	0.0041(5)	1.34(16)E-4	¹⁰⁴ Ru	143.206(9)	0.0206(20)	0.00062(6)
⁹³ Nb	5612.72(8)	0.0037(5)	1.21(16)E-4	¹⁰⁴ Ru	159.303(16)	0.0179(20)	0.00054(6)
⁹³ Nb	5645.93(7)	0.0026(4)	8.5(13)E-5	¹⁰² Ru	174.27(3)	0.076(7)	0.00228(21)
⁹³ Nb	5769.77(7)	0.0054(6)	1.76(20)E-4	⁹⁶ Ru	189.24(4)	0.0099(11)	0.00030(3)
⁹³ Nb	5880.80(9)	0.0035(4)	1.14(13)E-4	¹⁰² Ru	250.78(6)	0.0238(23)	0.00071(7)
⁹³ Nb	5895.01(7)	0.0183(8)	0.00060(3)	¹⁰² Ru	270.58(8)	0.034(3)	0.00102(9)
⁹³ Nb	5946.31(9)	0.0045(6)	1.47(20)E-4	¹⁰² Ru	294.66(4)	0.071(6)	0.00213(18)
⁹³ Nb	5954.41(10)	0.0025(3)	8.2(10)E-5				

^A Z	E _γ -keV	σ _γ ^Z (E _γ)-barns	k ₀	^A Z	E _γ -keV	σ _γ ^Z (E _γ)-barns	k ₀
¹⁰⁴ Ru	301.75(5)	0.0192(19)	0.00058(6)	¹⁰⁴ Ru	4943.1(3)	0.020(3)	0.00060(9)
¹⁰⁴ Ru	321.526(24)	0.0175(18)	0.00052(5)	¹⁰⁰ Ru	6266.6(3)	0.0180(13)	0.00054(4)
¹⁰² Ru	346.23(6)	0.030(3)	0.00090(9)	¹⁰¹ Ru	6274.68(4)	0.017(3)	0.00051(9)
¹⁰⁴ Ru	358.57(7)	0.0173(24)	0.00052(7)	⁹⁹ Ru	6340.59(6)	0.024(4)	0.00072(12)
¹⁰² Ru	403.10(5)	0.062(6)	0.00186(18)	¹⁰¹ Ru	6627.200(20)	0.093(9)	0.0028(3)
⁹⁹ Ru	403.18(8)	0.050(10)	0.0015(3)	¹⁰¹ Ru	6978.81(16)	0.041(5)	0.00123(15)
¹⁰¹ Ru	418.531(22)	0.033(4)	0.00099(12)	⁹⁹ Ru	7103.08(8)	0.018(3)	0.00054(9)
⁹⁹ Ru	424.87(5)	0.0170(21)	0.00051(6)	⁹⁹ Ru	7792.04(3)	0.132(13)	0.0040(4)
¹⁰² Ru	432.00(6)	0.0267(25)	0.00080(8)	Rhodium (Z=45), At. Wt.=102.90550(2), σ_γ^Z=145.0(20)			
¹⁰⁴ Ru	462.93(7)	0.025(3)	0.00075(9)	¹⁰³ Rh	32.18(4)	0.25(5)	0.0074(15)
¹⁰¹ Ru	468.69(4)	0.049(5)	0.00147(15)	¹⁰³ Rh	35.56(13)	0.65(7)	0.0191(21)
¹⁰¹Ru	475.0950(20)	0.98(9)	0.029(3)	¹⁰³ Rh	46.20(5)	0.37(5)	0.0109(15)
¹⁰² Ru	500.96(10)	0.0175(19)	0.00052(6)	¹⁰³Rh	51.50(3)d	5.2(3)	0.153[90%]
⁹⁹ Ru	518.92(4)	0.026(3)	0.00078(9)	¹⁰³Rh	51.50(3)	16.0(4)	0.471(12)
⁹⁹Ru	539.538(15)	1.53(13)	0.046(4)	¹⁰³ Rh	55.46(4)	0.76(15)	0.022(4)
¹⁰² Ru	545.44(5)	0.0253(25)	0.00076(8)	¹⁰³ Rh	80.80(3)	0.73(16)	0.021(5)
¹⁰² Ru	554.54(7)	0.027(3)	0.00081(9)	¹⁰³ Rh	83.74(3)	0.63(14)	0.019(4)
¹⁰⁴ Ru	562.70(6)	0.028(3)	0.00084(9)	¹⁰³Rh	85.19(3)	3.2(3)	0.094(9)
¹⁰² Ru	562.86(12)	0.017(4)	0.00051(12)	¹⁰³ Rh	85.97(4)	0.30(6)	0.0088(18)
⁹⁹ Ru	590.91(6)	0.053(5)	0.00159(15)	¹⁰³Rh	97.14(3)	19.5(4)	0.574(12)
¹⁰¹Ru	627.970(22)	0.176(16)	0.0053(5)	¹⁰³Rh	100.74(4)	4.96(10)	0.146(3)
¹⁰¹Ru	631.22(4)	0.30(3)	0.0090(9)	¹⁰³ Rh	105.40(6)	0.47(4)	0.0138(12)
⁹⁹ Ru	631.48(6)	0.017(5)	0.00051(15)	¹⁰³ Rh	118.10(3)	0.570(15)	0.0168(4)
¹⁰¹ Ru	636.86(6)	0.033(3)	0.00099(9)	¹⁰³ Rh	119.50(3)	1.5(3)	0.044(9)
¹⁰⁴ Ru	640.16(7)	0.0171(22)	0.00051(7)	¹⁰³Rh	127.20(3)	5.27(21)	0.155(6)
¹⁰¹ Ru	680.57(6)	0.0162(22)	0.00049(7)	¹⁰³ Rh	129.37(3)	0.465(20)	0.0137(6)
⁹⁹Ru	686.907(17)	0.52(5)	0.0156(15)	¹⁰³ Rh	131.86(6)	0.437(24)	0.0129(7)
¹⁰¹ Ru	692.28(9)	0.025(3)	0.00075(9)	¹⁰³Rh	134.54(3)	6.8(4)	0.200(12)
¹⁰¹ Ru	695.53(9)	0.039(5)	0.00117(15)	¹⁰³ Rh	135.16(4)	0.66(16)	0.019(5)
¹⁰¹ Ru	697.31(15)	0.020(3)	0.00060(9)	¹⁰³ Rh	137.65(3)	0.45(4)	0.0133(12)
⁹⁹ Ru	700.53(3)	0.018(3)	0.00054(9)	¹⁰³ Rh	138.74(4)	0.54(4)	0.0159(12)
⁹⁹ Ru	710.70(4)	0.034(3)	0.00102(9)	¹⁰³ Rh	146.72(3)	1.5(3)	0.044(9)
¹⁰⁴ Ru	724.30(3)d	0.0760(11)	0.00228[7.4%]	¹⁰³ Rh	157.00(3)	1.05(3)	0.0309(9)
⁹⁹ Ru	734.60(6)	0.0254(25)	0.00076(8)	¹⁰³ Rh	159.49(3)	0.380(16)	0.0112(5)
¹⁰¹ Ru	739.614(21)	0.0196(20)	0.00059(6)	¹⁰³ Rh	161.55(4)	1.00(3)	0.0294(9)
¹⁰¹ Ru	766.82(10)	0.019(3)	0.00057(9)	¹⁰³ Rh	165.20(4)	0.89(4)	0.0262(12)
⁹⁹ Ru	822.579(22)	0.137(12)	0.0041(4)	¹⁰³ Rh	168.21(5)	0.45(10)	0.013(3)
⁹⁹ Ru	836.20(3)	0.029(5)	0.00087(15)	¹⁰³Rh	169.16(5)	2.88(19)	0.085(6)
⁹⁹ Ru	849.23(4)	0.030(3)	0.00090(9)	¹⁰³ Rh	170.08(6)	0.64(19)	0.019(6)
¹⁰¹ Ru	940.42(3)	0.038(4)	0.00114(12)	¹⁰³ Rh	177.64(4)	1.85(12)	0.054(4)
¹⁰¹ Ru	1046.498(3)	0.103(9)	0.0031(3)	¹⁰³Rh	178.66(4)	3.27(14)	0.096(4)
¹⁰² Ru	1075.37(14)	0.0188(21)	0.00056(6)	¹⁰³Rh	180.87(3)	22.6(15)	0.67(4)
¹⁰¹ Ru	1103.062(22)	0.100(9)	0.0030(3)	¹⁰³ Rh	186.04(3)	1.50(5)	0.0442(15)
¹⁰¹ Ru	1105.54(6)	0.055(5)	0.00165(15)	¹⁰³ Rh	196.55(5)	0.80(16)	0.024(5)
⁹⁹ Ru	1107.20(5)	0.0236(24)	0.00071(7)	¹⁰³ Rh	198.89(4)	0.52(10)	0.015(3)
⁹⁹ Ru	1207.93(8)	0.022(6)	0.00066(18)	¹⁰³ Rh	202.85(6)	1.6(3)	0.047(9)
⁹⁹ Ru	1266.58(4)	0.0178(20)	0.00053(6)	¹⁰³ Rh	213.05(3)	1.27(3)	0.0374(9)
⁹⁹ Ru	1325.51(4)	0.034(4)	0.00102(12)	¹⁰³Rh	215.340(22)	5.20(12)	0.153(4)
⁹⁹ Ru	1341.50(3)	0.137(12)	0.0041(4)	¹⁰³ Rh	215.36(3)	1.54(12)	0.045(4)
⁹⁹ Ru	1362.111(24)	0.111(13)	0.0033(4)	¹⁰³Rh	216.54(8)	5.0(10)	0.15(3)
⁹⁹ Ru	1365.29(4)	0.023(3)	0.00069(9)	¹⁰³Rh	217.82(3)	7.38(13)	0.217(4)
⁹⁹ Ru	1520.71(8)	0.022(3)	0.00066(9)	¹⁰³ Rh	218.44(4)	0.30(6)	0.0088(18)
⁹⁹ Ru	1523.10(3)	0.034(4)	0.00102(12)	¹⁰³ Rh	219.85(4)	0.480(19)	0.0141(6)
⁹⁹ Ru	1535.75(19)	0.0155(21)	0.00046(6)	¹⁰³ Rh	222.74(5)	0.26(3)	0.0077(9)
⁹⁹ Ru	1559.51(6)	0.027(3)	0.00081(9)	¹⁰³ Rh	235.93(6)	0.345(10)	0.0102(3)
¹⁰¹ Ru	1568.383(20)	0.044(4)	0.00132(12)	¹⁰³ Rh	245.07(5)	0.29(4)	0.0085(12)
⁹⁹ Ru	1627.32(3)	0.129(12)	0.0039(4)	¹⁰³ Rh	245.45(4)	0.387(17)	0.0114(5)
⁹⁹ Ru	1701.11(7)	0.032(3)	0.00096(9)	¹⁰³ Rh	246.61(5)	0.27(5)	0.0080(15)
¹⁰² Ru	1730.6(3)	0.0176(23)	0.00053(7)	¹⁰³ Rh	247.55(5)	0.387(17)	0.0114(5)
⁹⁹ Ru	1827.09(5)	0.045(4)	0.00135(12)	¹⁰³ Rh	261.38(5)	1.09(3)	0.0321(9)
⁹⁹ Ru	1865.04(4)	0.028(3)	0.00084(9)	¹⁰³Rh	266.84(3)	2.66(17)	0.078(5)
⁹⁹ Ru	1929.77(4)	0.025(3)	0.00075(9)	¹⁰³ Rh	269.18(3)	1.42(11)	0.042(3)
¹⁰²Ru	1959.30(7)	0.210(19)	0.0063(6)	¹⁰³ Rh	273.62(3)	0.814(18)	0.0240(5)
⁹⁹ Ru	1996.62(6)	0.0223(25)	0.00067(8)	¹⁰³ Rh	284.36(4)	0.26(3)	0.0077(9)
¹⁰² Ru	2074.98(20)	0.022(3)	0.00066(9)	¹⁰³ Rh	286.18(8)	0.42(4)	0.0124(12)
⁹⁹ Ru	3016.61(9)	0.0175(21)	0.00052(6)	¹⁰³ Rh	303.59(5)	0.794(17)	0.0234(5)
⁹⁹ Ru	3981.1(3)	0.0186(24)	0.00056(7)	¹⁰³ Rh	305.7(3)	1.070(21)	0.0315(6)
¹⁰² Ru	4627.38(14)	0.0187(24)	0.00056(7)	¹⁰³ Rh	317.07(4)	0.74(3)	0.0218(9)

^A Z	E _γ -keV	σ _γ ^Z (E _γ)-barns	k ₀
¹⁰³ Rh	323.48(4)	1.54(19)	0.045(6)
¹⁰³ Rh	324.64(4)	0.57(9)	0.017(3)
¹⁰³Rh	333.44(3)	3.27(8)	0.0963(24)
¹⁰³ Rh	352.99(3)	0.668(19)	0.0197(6)
¹⁰³ Rh	352.99(3)	0.668(19)	0.0197(6)
¹⁰³ Rh	356.82(3)	0.668(19)	0.0197(6)
¹⁰³ Rh	370.48(7)	0.429(18)	0.0126(5)
¹⁰³ Rh	374.826(23)	1.300(25)	0.0383(7)
¹⁰³ Rh	379.823(5)	0.301(21)	0.0089(6)
¹⁰³ Rh	382.24(3)	0.374(25)	0.0110(7)
¹⁰³ Rh	385.10(3)	0.819(19)	0.0241(6)
¹⁰³ Rh	391.18(5)	0.358(17)	0.0105(5)
¹⁰³ Rh	403.96(11)	0.350(15)	0.0103(4)
¹⁰³ Rh	408.16(4)	0.293(18)	0.0086(5)
¹⁰³ Rh	420.62(3)	2.06(4)	0.0607(12)
¹⁰³ Rh	427.44(3)	1.12(3)	0.0330(9)
¹⁰³ Rh	431.91(12)	0.461(23)	0.0136(7)
¹⁰³ Rh	440.55(3)	2.23(10)	0.066(3)
¹⁰³ Rh	459.69(6)	0.555(17)	0.0163(5)
¹⁰³Rh	470.40(3)	2.61(7)	0.0769(21)
¹⁰³ Rh	482.230(25)	1.78(6)	0.0524(18)
¹⁰³ Rh	497.80(4)	0.88(4)	0.0259(12)
¹⁰³ Rh	503.00(13)	0.23(6)	0.0068(18)
¹⁰³ Rh	529.98(5)	0.885(21)	0.0261(6)
¹⁰³Rh	538.04(3)	2.43(7)	0.0716(21)
¹⁰³ Rh	542.31(8)	0.48(3)	0.0141(9)
¹⁰³ Rh	550.87(8)	0.31(3)	0.0091(9)
¹⁰³Rh	555.81(4)d	3.14(9)	0.0921[98%]
¹⁰³ Rh	562.78(4)	0.299(22)	0.0088(7)
¹⁰³ Rh	574.07(5)	0.539(20)	0.0159(6)
¹⁰³ Rh	577.92(5)	0.342(19)	0.0101(6)
¹⁰³ Rh	597.65(3)	0.997(23)	0.0294(7)
¹⁰³ Rh	609.55(12)	0.58(3)	0.0171(9)
¹⁰³ Rh	633.45(6)	0.239(17)	0.0070(5)
¹⁰³ Rh	680.61(6)	0.25(5)	0.0074(15)
¹⁰³ Rh	689.47(5)	0.35(8)	0.0103(24)
¹⁰³ Rh	695.38(7)	1.07(3)	0.0315(9)
¹⁰³ Rh	702.72(7)	0.869(25)	0.0256(7)
¹⁰³ Rh	707.67(6)	0.843(25)	0.0248(7)
¹⁰³ Rh	710.69(5)	0.46(4)	0.0135(12)
¹⁰³ Rh	718.26(6)	0.267(10)	0.0079(3)
¹⁰³ Rh	720.58(9)	0.297(9)	0.0087(3)
¹⁰³ Rh	722.81(4)	0.255(11)	0.0075(3)
¹⁰³ Rh	734.90(7)	0.68(5)	0.0200(15)
¹⁰³ Rh	762.83(6)	0.339(21)	0.0100(6)
¹⁰³ Rh	787.12(4)	1.16(3)	0.0342(9)
¹⁰³ Rh	790.43(12)	0.7(4)	0.021(12)
¹⁰³ Rh	791.41(7)	0.84(5)	0.0247(15)
¹⁰³ Rh	817.71(8)	0.5(3)	0.015(9)
¹⁰³ Rh	834.94(7)	0.277(13)	0.0082(4)
¹⁰³ Rh	868.28(6)	0.56(3)	0.0165(9)
¹⁰³ Rh	872.24(4)	0.440(16)	0.0130(5)
¹⁰³ Rh	907.66(7)	0.28(6)	0.0082(18)
¹⁰³ Rh	951.96(6)	1.090(24)	0.0321(7)
¹⁰³ Rh	5798.18(14)	0.59(3)	0.0174(9)
¹⁰³ Rh	5917.43(5)	1.31(4)	0.0386(12)
¹⁰³ Rh	6046.79(6)	0.88(4)	0.0259(12)
¹⁰³ Rh	6082.98(7)	0.58(4)	0.0171(12)
¹⁰³ Rh	6110.21(6)	0.278(19)	0.0082(6)
¹⁰³ Rh	6172.33(5)	0.75(3)	0.0221(9)
¹⁰³ Rh	6211.62(4)	0.89(3)	0.0262(9)
¹⁰³ Rh	6354.87(7)	0.46(3)	0.0135(9)
¹⁰³ Rh	6785.66(4)	0.470(20)	0.0138(6)
Palladium (Z=46), At. Wt.=106.42(1), σ_γ^Z=6.9(4)			
¹⁰⁸ Pd	113.4010(10)	0.335(5)	0.00954(14)
¹⁰⁶ Pd	115.86(7)	0.0141(13)	0.00040(4)
¹⁰² Pd	118.68(3)	0.0042(11)	1.2(3)E-4
¹⁰⁸ Pd	152.9420(10)	0.1450(22)	0.00413(6)

^A Z	E _γ -keV	σ _γ ^Z (E _γ)-barns	k ₀
¹⁰⁸ Pd	178.0340(10)	0.1090(22)	0.00310(6)
¹⁰⁸ Pd	188.9900(10)d	0.0273(15)	0.00078[89%]
¹⁰⁸ Pd	197.346(5)	0.0650(20)	0.00185(6)
¹⁰⁸ Pd	211.8840(20)	0.0540(18)	0.00154(5)
¹⁰⁸ Pd	245.0790(20)	0.250(4)	0.00712(11)
¹⁰⁸ Pd	266.3430(20)	0.0515(12)	0.00147(3)
¹⁰⁸ Pd	276.289(6)	0.0562(18)	0.00160(5)
¹⁰⁴ Pd	280.65(6)	0.0158(14)	0.00045(4)
¹⁰⁸ Pd	291.4350(20)	0.1040(20)	0.00296(6)
¹⁰⁸ Pd	325.2840(20)	0.208(3)	0.00592(9)
¹⁰⁸ Pd	326.8690(20)	0.0793(20)	0.00226(6)
¹⁰⁸ Pd	333.960(4)	0.1110(25)	0.00316(7)
¹⁰⁸ Pd	339.5290(20)	0.195(3)	0.00555(9)
¹⁰⁸ Pd	359.4290(20)	0.120(3)	0.00342(9)
¹⁰⁸ Pd	378.1890(20)	0.0411(20)	0.00117(6)
¹⁰⁸ Pd	428.409(4)	0.0504(21)	0.00144(6)
¹⁰⁵ Pd	429.63(4)	0.145(3)	0.00413(9)
¹⁰⁸ Pd	433.5640(20)	0.097(3)	0.00276(9)
¹⁰⁵Pd	511.843(20)	4.00(4)	0.1139(11)
¹⁰⁵Pd	616.192(20)	0.629(9)	0.0179(3)
¹⁰⁵ Pd	621.95(6)	0.126(7)	0.00359(20)
¹⁰⁸ Pd	685.914(8)	0.042(7)	0.00120(20)
¹⁰⁵Pd	717.356(22)	0.777(9)	0.0221(3)
¹⁰⁵ Pd	748.34(5)	0.0802(23)	0.00228(7)
¹⁰⁸ Pd	754.894(9)	0.0474(18)	0.00135(5)
¹⁰⁵ Pd	804.33(4)	0.091(3)	0.00259(9)
¹⁰⁵ Pd	846.29(10)	0.0452(18)	0.00129(5)
¹⁰⁵ Pd	848.16(6)	0.1000(25)	0.00285(7)
¹⁰⁸ Pd	1019.872(9)	0.0467(25)	0.00133(7)
¹⁰⁵ Pd	1045.82(3)	0.321(7)	0.00914(20)
¹⁰⁵ Pd	1050.31(4)	0.360(8)	0.01025(23)
¹⁰⁵ Pd	1053.68(9)	0.057(3)	0.00162(9)
¹⁰⁵ Pd	1128.03(3)	0.323(6)	0.00920(17)
¹⁰⁵ Pd	1168.16(8)	0.0588(22)	0.00167(6)
¹⁰⁵ Pd	1397.54(7)	0.089(3)	0.00253(9)
¹⁰⁵ Pd	1572.54(7)	0.207(25)	0.0059(7)
¹⁰⁵ Pd	1909.40(11)	0.0423(20)	0.00120(6)
¹⁰⁵ Pd	1927.25(10)	0.041(3)	0.00117(9)
¹⁰⁵ Pd	1988.14(12)	0.060(4)	0.00171(11)
¹⁰⁵ Pd	2484.73(25)	0.052(4)	0.00148(11)
¹⁰⁸ Pd	4794.02(12)	0.112(10)	0.0032(3)
¹⁰⁸ Pd	5212.31(12)	0.061(5)	0.00174(14)
¹¹⁰ Pd	5531.9(4)	0.0120(20)	0.00034(6)
Silver (Z=47), At. Wt.=107.8682(2), σ_γ^Z=63.3(8)			
¹⁰⁹ Ag	68.36(4)	0.113(8)	0.00317(22)
¹⁰⁹Ag	72.67(5)	~0.9	~0.03
¹⁰⁷Ag	78.91(4)	3.90(12)	0.110(3)
¹⁰⁹Ag	79.91(6)	~1.0	~0.03
¹⁰⁹ Ag	93.34(5)	0.5(3)	0.014(8)
¹⁰⁷ Ag	101.55(8)	0.189(20)	0.0053(6)
¹⁰⁹Ag	105.95(6)	0.87(13)	0.024(4)
¹⁰⁷ Ag	110.24(7)	0.273(22)	0.0077(6)
¹⁰⁷ Ag	113.51(6)	0.52(3)	0.0146(8)
¹⁰⁹Ag	117.45(8)	3.85(7)	0.1082(20)
¹⁰⁹ Ag	124.86(5)	0.158(12)	0.0044(3)
¹⁰⁷ Ag	143.94(4)	0.121(5)	0.00340(14)
¹⁰⁷ Ag	147.11(4)	0.114(5)	0.00320(14)
¹⁰⁷ Ag	148.79(3)	0.214(6)	0.00601(17)
¹⁰⁹ Ag	152.58(4)	0.326(6)	0.00916(17)
¹⁰⁷ Ag	155.22(11)	0.081(13)	0.0023(4)
¹⁰⁹ Ag	161.69(5)	0.217(8)	0.00610(22)
¹⁰⁹ Ag	166.62(4)	0.295(10)	0.0083(3)
¹⁰⁷ Ag	178.32(4)	0.208(8)	0.00584(22)
¹⁰⁷Ag	191.39(3)	1.81(5)	0.0509(14)
¹⁰⁷Ag	192.90(3)	2.20(6)	0.0618(17)
¹⁰⁹ Ag	194.56(14)	~0.2	~0.006
¹⁰⁹ Ag	195.33(6)	0.50(3)	0.0140(8)
¹⁰⁹ Ag	195.74(8)	~0.2	~0.006

A	Z	E_{γ} -keV	$\sigma_{\gamma}^Z(E_{\gamma})$ -barns	k_0	A	Z	E_{γ} -keV	$\sigma_{\gamma}^Z(E_{\gamma})$ -barns	k_0
¹⁰⁹	Ag	198.72(4)	7.75(13)	0.218(4)	¹⁰⁹	Ag	488.66(6)	0.149(12)	0.0042(3)
¹⁰⁷	Ag	201.31(6)	0.45(3)	0.0126(8)	¹⁰⁹	Ag	495.71(3)	1.080(18)	0.0303(5)
¹⁰⁷	Ag	204.02(9)	0.088(22)	0.0025(6)	¹⁰⁷	Ag	497.57(8)	0.157(9)	0.00441(25)
¹⁰⁷	Ag	206.46(3)	3.58(7)	0.1006(20)	¹⁰⁷	Ag	499.97(4)	0.265(13)	0.0074(4)
¹⁰⁷	Ag	212.30(4)	0.26(4)	0.0073(11)	¹⁰⁷	Ag	522.43(9)	0.125(7)	0.00351(20)
¹⁰⁷	Ag	215.15(4)	1.55(3)	0.0435(8)	¹⁰⁹	Ag	524.47(3)	0.804(11)	0.0226(3)
¹⁰⁹	Ag	220.77(10)	~0.08	~0.002	¹⁰⁹	Ag	526.07(8)	0.364(7)	0.01023(20)
¹⁰⁹	Ag	231.46(5)	0.224(12)	0.0063(3)	¹⁰⁷	Ag	527.23(5)	0.371(10)	0.0104(3)
¹⁰⁹	Ag	235.62(4)	4.62(7)	0.1298(20)	¹⁰⁹	Ag	536.13(3)	1.090(16)	0.0306(5)
¹⁰⁷	Ag	236.85(4)	1.95(3)	0.0548(8)	¹⁰⁹	Ag	544.14(5)	0.34(3)	0.0096(8)
¹⁰⁹	Ag	236.89(7)	1.3(9)	0.037(25)	¹⁰⁹	Ag	549.56(3)	1.540(24)	0.0433(7)
¹⁰⁷	Ag	237.63(3)	0.26(5)	0.0073(14)	¹⁰⁷	Ag	563.91(5)	0.191(6)	0.00537(17)
¹⁰⁷	Ag	239.10(4)	0.327(11)	0.0092(3)	¹⁰⁷	Ag	572.10(6)	0.080(6)	0.00225(17)
¹⁰⁷	Ag	244.56(6)	0.146(20)	0.0041(6)	¹⁰⁷	Ag	574.77(3)	0.299(7)	0.00840(20)
¹⁰⁷	Ag	249.15(6)	0.087(7)	0.00244(20)	¹⁰⁹	Ag	586.85(3)	0.459(8)	0.01290(22)
¹⁰⁹	Ag	252.17(5)	0.096(6)	0.00270(17)	¹⁰⁹	Ag	593.86(4)	0.484(11)	0.0136(3)
¹⁰⁷	Ag	259.17(3)	1.560(25)	0.0438(7)	¹⁰⁷	Ag	599.87(4)	0.37(3)	0.0104(8)
¹⁰⁷	Ag	262.31(6)	0.161(11)	0.0045(3)	¹⁰⁹	Ag	610.33(15)	0.105(25)	0.0029(7)
¹⁰⁹	Ag	267.08(3)	2.73(6)	0.0767(17)	¹⁰⁷	Ag	611.98(18)	0.09(3)	0.0025(8)
¹⁰⁹	Ag	269.05(4)	0.6(5)	0.017(14)	¹⁰⁹	Ag	614.15(8)	0.20(5)	0.0056(14)
¹⁰⁹	Ag	269.97(4)	0.565(25)	0.0159(7)	¹⁰⁷	Ag	616.89(4)	0.20(4)	0.0056(11)
¹⁰⁹	Ag	282.66(6)	0.079(10)	0.0022(3)	¹⁰⁹	Ag	620.07(5)	0.40(5)	0.0112(14)
¹⁰⁷	Ag	286.91(4)	0.400(25)	0.0112(7)	¹⁰⁷	Ag	626.41(4)	0.39(6)	0.0110(17)
¹⁰⁷	Ag	294.39(3)	2.05(12)	0.058(3)	¹⁰⁷	Ag	629.499(20)	0.12(3)	0.0034(8)
¹⁰⁷	Ag	295.22(18)	0.10(4)	0.0028(11)	¹⁰⁹	Ag	632.47(10)	0.42(12)	0.012(3)
¹⁰⁷	Ag	299.95(3)	1.15(5)	0.0323(14)	¹⁰⁷	Ag	636.53(4)	0.31(11)	0.009(3)
¹⁰⁷	Ag	301.75(7)	0.187(15)	0.0053(4)	¹⁰⁷	Ag	640.18(4)	0.24(6)	0.0067(17)
¹⁰⁹	Ag	302.83(13)	0.129(14)	0.0036(4)	¹⁰⁷	Ag	652.041(20)	0.117(19)	0.0033(5)
¹⁰⁹	Ag	304.43(15)	0.135(9)	0.00379(25)	¹⁰⁹	Ag	652.96(5)	0.255(12)	0.0072(3)
¹⁰⁹	Ag	316.88(3)	0.206(7)	0.00579(20)	¹⁰⁹	Ag	655.02(11)	0.107(14)	0.0030(4)
¹⁰⁷	Ag	320.36(6)	0.091(7)	0.00256(20)	¹⁰⁹	Ag	657.50(10)d	1.86(5)	0.0523[99%]
¹⁰⁷	Ag	328.99(3)	0.795(12)	0.0223(3)	¹⁰⁷	Ag	662.55(11)	0.088(12)	0.0025(3)
¹⁰⁹	Ag	338.74(3)	0.595(10)	0.0167(3)	¹⁰⁷	Ag	664.91(3)	0.329(22)	0.0092(6)
¹⁰⁷	Ag	349.95(3)	0.70(4)	0.0197(11)	¹⁰⁷	Ag	670.53(7)	0.104(17)	0.0029(5)
¹⁰⁷	Ag	350.99(9)	0.145(12)	0.0041(3)	¹⁰⁷	Ag	674.07(6)	0.094(16)	0.0026(5)
¹⁰⁹	Ag	357.82(5)	0.561(22)	0.0158(6)	¹⁰⁷	Ag	685.8(3)	0.081(20)	0.0023(6)
¹⁰⁹	Ag	360.41(3)	1.55(3)	0.0435(8)	¹⁰⁷	Ag	687.48(8)	0.35(5)	0.0098(14)
¹⁰⁷	Ag	365.41(23)	0.16(4)	0.0045(11)	¹⁰⁹	Ag	698.44(6)	0.158(6)	0.00444(17)
¹⁰⁹	Ag	366.97(10)	0.21(4)	0.0059(11)	¹⁰⁷	Ag	718.17(6)	0.199(12)	0.0056(3)
¹⁰⁷	Ag	372.1(3)	0.09(3)	0.0025(8)	¹⁰⁹	Ag	724.75(5)	0.393(14)	0.0110(4)
¹⁰⁷	Ag	376.71(9)	0.294(13)	0.0083(4)	¹⁰⁷	Ag	746.21(19)	0.088(10)	0.0025(3)
¹⁰⁹	Ag	378.11(6)	0.744(20)	0.0209(6)	¹⁰⁹	Ag	748.40(6)	0.328(9)	0.00921(25)
¹⁰⁷	Ag	380.90(3)	1.59(3)	0.0447(8)	¹⁰⁹	Ag	750.77(4)	0.529(11)	0.0149(3)
¹⁰⁹	Ag	380.97(15)	0.7(5)	0.020(14)	¹⁰⁹	Ag	767.01(5)	0.31(4)	0.0087(11)
¹⁰⁷	Ag	384.31(13)	0.128(22)	0.0036(6)	¹⁰⁹	Ag	773.32(8)	0.22(3)	0.0062(8)
¹⁰⁷	Ag	386.18(13)	0.192(24)	0.0054(7)	¹⁰⁷	Ag	781.21(11)	0.094(22)	0.0026(6)
¹⁰⁹	Ag	387.99(7)	0.121(21)	0.0034(6)	¹⁰⁹	Ag	785.57(5)	0.34(4)	0.0096(11)
¹⁰⁷	Ag	396.25(4)	0.138(6)	0.00388(17)	¹⁰⁷	Ag	796.15(8)	0.38(4)	0.0107(11)
¹⁰⁷	Ag	399.87(7)	0.093(6)	0.00261(17)	¹⁰⁷	Ag	812.10(6)	0.131(5)	0.00368(14)
¹⁰⁹	Ag	408.61(4)	0.459(9)	0.01290(25)	¹⁰⁷	Ag	819.26(8)	0.291(6)	0.00818(17)
¹⁰⁷	Ag	410.31(6)	0.142(6)	0.00399(17)	¹⁰⁷	Ag	845.19(14)	0.085(19)	0.0024(5)
¹⁰⁹	Ag	416.93(5)	0.243(13)	0.0068(4)	¹⁰⁷	Ag	881.01(7)	0.178(7)	0.00500(20)
¹⁰⁹	Ag	427.96(16)	0.273(11)	0.0077(3)	¹⁰⁷	Ag	895.48(3)	0.376(8)	0.01056(22)
¹⁰⁷	Ag	429.09(7)	0.253(11)	0.0071(3)	¹⁰⁷	Ag	918.97(11)	0.124(22)	0.0035(6)
¹⁰⁹	Ag	431.36(7)	0.248(13)	0.0070(4)	¹⁰⁷	Ag	938.04(5)	0.186(6)	0.00523(17)
¹⁰⁷	Ag	437.713(15)	0.079(10)	0.0022(3)	¹⁰⁷	Ag	960.13(4)	0.199(10)	0.0056(3)
¹⁰⁷	Ag	438.26(12)	0.191(11)	0.0054(3)	¹⁰⁷	Ag	972.69(7)	0.078(9)	0.00219(25)
¹⁰⁷	Ag	439.69(12)	0.216(11)	0.0061(3)	¹⁰⁷	Ag	1013.11(3)	0.698(13)	0.0196(4)
¹⁰⁷	Ag	441.79(8)	0.181(21)	0.0051(6)	¹⁰⁷	Ag	1051.36(5)	0.225(8)	0.00632(22)
¹⁰⁹	Ag	446.10(7)	0.183(10)	0.0051(3)	¹⁰⁷	Ag	1079.68(13)	0.165(15)	0.0046(4)
¹⁰⁹	Ag	450.80(7)	0.098(16)	0.0028(5)	¹⁰⁹	Ag	5539.17(21)	0.106(9)	0.00298(25)
¹⁰⁹	Ag	461.56(6)	0.265(16)	0.0074(5)	¹⁰⁹	Ag	5545.6(3)	0.106(12)	0.0030(3)
¹⁰⁷	Ag	464.04(12)	0.236(20)	0.0066(6)	¹⁰⁹	Ag	5554.8(3)	0.111(10)	0.0031(3)
¹⁰⁷	Ag	465.37(6)	0.46(3)	0.0129(8)	¹⁰⁹	Ag	5580.62(19)	0.302(14)	0.0085(4)
¹⁰⁹	Ag	468.65(7)	0.166(9)	0.00466(25)	¹⁰⁹	Ag	5615.11(20)	0.208(11)	0.0058(3)
¹⁰⁷	Ag	479.36(7)	0.095(12)	0.0027(3)	¹⁰⁹	Ag	5642.24(22)	0.199(12)	0.0056(3)
¹⁰⁹	Ag	484.18(8)	0.253(18)	0.0071(5)	¹⁰⁹	Ag	5701.49(19)	0.716(18)	0.0201(5)
¹⁰⁷	Ag	485.68(13)	0.098(7)	0.00275(20)	¹⁰⁹	Ag	5710.22(20)	0.229(10)	0.0064(3)

^A Z	E _γ -keV	σ _γ ^Z (E _γ)-barns	k ₀	^A Z	E _γ -keV	σ _γ ^Z (E _γ)-barns	k ₀
¹⁰⁹ Ag	5773.12(21)	0.225(9)	0.00632(25)	¹¹⁵ In	126.3720(20)	4.0(3)	0.106(8)
¹⁰⁹ Ag	5795.0(3)	0.513(14)	0.0144(4)	¹¹⁵ In	138.326(8)d	5.11(18)	0.135[30%]
¹⁰⁹ Ag	5913.3(5)	0.084(7)	0.00236(20)	¹¹⁵ In	140.4560(20)	1.58(11)	0.042(3)
¹⁰⁹ Ag	5996.81(10)	0.154(7)	0.00433(20)	¹¹⁵ In	141.1700(20)	2.63(18)	0.069(5)
¹⁰⁹ Ag	6022.46(10)	0.250(10)	0.0070(3)	¹¹⁵ In	149.6700(20)	0.69(5)	0.0182(13)
¹⁰⁹ Ag	6034.70(11)	0.080(6)	0.00225(17)	¹¹⁵ In	155.272(3)	2.48(18)	0.065(5)
¹⁰⁹ Ag	6057.25(9)	0.663(19)	0.0186(5)	¹¹⁵ In	159.932(4)	1.07(7)	0.0282(18)
¹⁰⁹ Ag	6101.98(11)	0.080(5)	0.00225(14)	¹¹⁵ In	162.393(3)d	15.8(8)	0.417[100%]
¹⁰⁷ Ag	6268.80(24)	0.146(7)	0.00410(20)	¹¹⁵ In	163.802(8)	0.67(5)	0.0177(13)
¹⁰⁷ Ag	6372.7(9)	0.11(4)	0.0031(11)	¹¹⁵ In	171.059(5)	3.44(25)	0.091(7)
¹⁰⁹ Ag	6540.92(9)	0.259(11)	0.0073(3)	¹¹⁵ In	173.886(6)	4.1(3)	0.108(8)
¹⁰⁷ Ag	6707.6(3)	0.083(7)	0.00233(20)	¹¹⁵ In	175.066(4)	1.12(7)	0.0296(18)
¹⁰⁹ Ag	6807.13(11)	0.083(3)	0.00233(8)	¹¹⁵ In	186.2100(20)	26.6(18)	0.70(5)
¹⁰⁷ Ag	6892.1(3)	0.079(6)	0.00222(17)	¹¹⁵ In	196.738(5)	0.89(7)	0.0235(18)
¹⁰⁷ Ag	6977.2(3)	0.121(8)	0.00340(22)	¹¹⁵ In	202.602(3)	2.70(20)	0.071(5)
¹⁰⁷ Ag	7065.3(3)	0.103(8)	0.00289(22)	¹¹⁵ In	213.625(12)	0.64(5)	0.0169(13)
¹⁰⁷ Ag	7078.5(3)	0.291(13)	0.0082(4)	¹¹⁵ In	234.618(11)	0.71(25)	0.019(7)
¹⁰⁷ Ag	7271.8(3)	0.284(14)	0.0080(4)	¹¹⁵ In	235.275(4)	4.9(3)	0.129(8)
Cadmium (Z=48), At.Wt.=112.411(8), σ_γ^Z=2522(50)				¹¹⁵ In	240.30(3)	0.44(3)	0.0116(8)
¹¹³ Cd	95.88(4)	21.2(6)	0.572(16)	¹¹⁵ In	267.960(20)	0.52(4)	0.0137(11)
¹¹⁰ Cd	171.3(3)	57(6)	1.54(16)	¹¹⁵ In	272.9660(20)	33.1(24)	0.87(6)
¹¹⁰ Cd	245.3(3)	274(25)	7.4(7)	¹¹⁵ In	284.914(4)	4.5(3)	0.119(8)
¹¹⁰ Cd	284.3(3)	29(3)	0.78(8)	¹¹³ In	287.726(19)	0.20(5)	0.0053(13)
¹¹⁰ Cd	342.2(3)	1.00E+02	2.70E+00	¹¹⁵ In	290.952(15)	2.55(18)	0.067(5)
¹¹³ Cd	558.32(3)	1860(30)	50.1(8)	¹¹⁵ In	293.393(15)	0.40(16)	0.011(4)
¹¹³ Cd	576.04(3)	107.0(17)	2.88(5)	¹¹⁵ In	293.644(14)	1.38(11)	0.036(3)
¹¹¹ Cd	617.54(15)	2.9(4)	0.078(11)	¹¹⁵ In	295.515(17)	2.86(20)	0.075(5)
¹¹⁰ Cd	620.3(3)	38(4)	1.02(11)	¹¹⁵ In	298.664(3)	9.4(7)	0.248(18)
¹¹³ Cd	648.79(10)	34.1(9)	0.919(24)	¹¹⁵ In	300.388(4)	0.45(3)	0.0119(8)
¹¹³ Cd	651.19(3)	358(5)	9.65(13)	¹¹⁵ In	305.108(8)	1.30(9)	0.0343(24)
¹¹³ Cd	654.47(4)	34.1(9)	0.919(24)	¹¹⁵ In	315.053(12)	0.69(5)	0.0182(13)
¹¹³ Cd	707.39(3)	29.3(5)	0.790(13)	¹¹⁵ In	318.48(4)	0.60(4)	0.0158(11)
¹¹³ Cd	725.19(3)	107.0(13)	2.88(4)	¹¹⁵ In	320.895(8)	2.30(16)	0.061(4)
¹¹³ Cd	748.04(6)	37(3)	1.00(8)	¹¹⁵ In	321.653(18)	0.7(3)	0.018(8)
¹¹³ Cd	805.85(3)	134.0(18)	3.61(5)	¹¹⁵ In	335.450(10)	9.1(7)	0.240(18)
¹¹³ Cd	1209.65(4)	122.0(19)	3.29(5)	¹¹⁵ In	337.687(8)	2.52(18)	0.067(5)
¹¹³ Cd	1283.45(4)	47.5(9)	1.281(24)	¹¹⁵ In	339.15(4)	0.47(11)	0.012(3)
¹¹³ Cd	1300.98(5)	31.1(11)	0.84(3)	¹¹⁵ In	364.995(20)	0.53(4)	0.0140(11)
¹¹³ Cd	1364.30(4)	123.0(21)	3.32(6)	¹¹⁵ In	373.149(24)	0.38(3)	0.0100(8)
¹¹³ Cd	1370.55(5)	30.2(9)	0.814(24)	¹¹⁵ In	375.969(12)	2.66(20)	0.070(5)
¹¹³ Cd	1399.54(4)	97.7(15)	2.63(4)	¹¹⁵ In	384.421(11)	2.9(7)	0.077(18)
¹¹³ Cd	1489.53(4)	68.5(11)	1.85(3)	¹¹⁵ In	385.111(8)	12.1(9)	0.319(24)
¹¹³ Cd	1660.36(5)	66.7(13)	1.80(4)	¹¹⁵ In	387.636(13)	0.344(25)	0.0091(7)
¹¹³ Cd	1826.19(7)	25.2(7)	0.679(19)	¹¹⁵ In	393.09(11)	0.39(3)	0.0103(8)
¹¹³ Cd	2102.39(8)	24.0(9)	0.647(24)	¹¹⁵ In	396.496(12)	0.51(4)	0.0135(11)
¹¹³ Cd	2398.27(12)	22.4(8)	0.604(22)	¹¹⁵ In	410.433(11)	0.69(5)	0.0182(13)
¹¹³ Cd	2455.93(7)	87.3(18)	2.35(5)	¹¹⁵ In	416.86(3)d	43.0(18)	1.13[30%]
¹¹³ Cd	2550.30(8)	38.7(11)	1.04(3)	¹¹⁵ In	422.213(11)	1.70(13)	0.045(3)
¹¹³ Cd	2659.96(7)	64.0(15)	1.73(4)	¹¹⁵ In	433.723(8)	6.0(4)	0.158(11)
¹¹³ Cd	2767.67(13)	22.4(13)	0.60(4)	¹¹⁵ In	443.229(13)	0.58(4)	0.0153(11)
¹¹³ Cd	2799.98(9)	27.6(9)	0.744(24)	¹¹⁵ In	447.531(11)	0.39(3)	0.0103(8)
¹¹³ Cd	2999.69(12)	29.1(14)	0.78(4)	¹¹⁵ In	471.349(11)	4.3(3)	0.113(8)
¹¹³ Cd	3109.08(12)	28.6(12)	0.77(3)	¹¹⁵ In	475.906(10)	1.88(13)	0.050(3)
¹¹³ Cd	3218.96(12)	19.0(9)	0.512(24)	¹¹⁵ In	489.314(10)	0.63(5)	0.0166(13)
¹¹³ Cd	5824.31(16)	69.1(18)	1.86(5)	¹¹⁵ In	490.374(12)	0.80(11)	0.021(3)
¹¹³ Cd	5934.39(20)	19.3(10)	0.52(3)	¹¹⁵ In	492.532(11)	3.31(24)	0.087(6)
Indium (Z=49), At.Wt.=114.818(3), σ_γ^Z=272(8)				¹¹⁵ In	497.670(19)	0.67(5)	0.0177(13)
¹¹⁵ In	22.796(7)	7(3)	0.18(8)	¹¹⁵ In	499.875(8)	0.37(3)	0.0098(8)
¹¹⁵ In	60.9160(10)	15.8(11)	0.42(3)	¹¹⁵ In	515.661(8)	0.60(4)	0.0158(11)
¹¹⁵ In	76.7580(20)	0.41(3)	0.0108(8)	¹¹⁵ In	517.957(20)	2.8(4)	0.074(11)
¹¹⁵ In	84.3080(20)	1.32(9)	0.0348(24)	¹¹⁵ In	518.119(12)	3.15(22)	0.083(6)
¹¹⁵ In	85.5690(20)	22.1(16)	0.58(4)	¹¹⁵ In	521.501(9)	1.97(14)	0.052(4)
¹¹⁵ In	95.380(4)	1.0(4)	0.026(11)	¹¹⁵ In	540.382(8)	0.60(4)	0.0158(11)
¹¹⁵ In	96.036(5)	11.4(14)	0.30(4)	¹¹⁵ In	548.720(9)	2.01(14)	0.053(4)
¹¹⁵ In	96.062(3)	24.6(18)	0.65(5)	¹¹⁵ In	555.47(11)	0.7(5)	0.018(13)
¹¹⁵ In	112.4540(20)	1.38(9)	0.0364(24)	¹¹⁵ In	556.169(8)	1.6(9)	0.042(24)
¹¹⁵ In	114.997(3)	0.47(3)	0.0124(8)	¹¹⁵ In	556.845(21)	4.7(3)	0.124(8)
				¹¹⁵ In	560.095(9)	0.85(5)	0.0224(13)

^A Z	E _γ -keV	σ _γ ^z (E _γ)-barns	k ₀
¹¹⁵ In	567.596(20)	0.94(7)	0.0248(18)
¹¹⁵ In	577.523(18)	1.92(14)	0.051(4)
¹¹⁵ In	602.36(4)	2.86(20)	0.075(5)
¹¹⁵ In	608.422(11)	3.51(25)	0.093(7)
¹¹⁵ In	622.57(11)	0.83(5)	0.0219(13)
¹¹⁵ In	633.740(11)	1.54(11)	0.041(3)
¹¹⁵ In	634.288(9)	1.68(13)	0.044(3)
¹¹⁵ In	647.72(8)	1.18(9)	0.0311(24)
¹¹⁵ In	654.95(7)	0.47(3)	0.0124(8)
¹¹⁵ In	657.084(11)	1.52(11)	0.040(3)
¹¹⁵ In	662.115(10)	0.44(3)	0.0116(8)
¹¹⁵ In	693.29(9)	1.83(13)	0.048(3)
¹¹⁵ In	706.21(10)	0.40(9)	0.0106(24)
¹¹⁵ In	746.978(9)	0.71(5)	0.0187(13)
¹¹⁵ In	771.01(8)	1.52(11)	0.040(3)
¹¹⁵ In	792.16(6)	1.34(9)	0.0354(24)
¹¹⁵ In	807.897(25)	0.44(3)	0.0116(8)
¹¹⁵ In	818.70(20)d	17.8(7)	0.470[30%]
¹¹⁵ In	819.04(11)	2.59(18)	0.068(5)
¹¹⁵ In	847.54(8)	2.15(16)	0.057(4)
¹¹⁵ In	992.10(10)	0.91(7)	0.0240(18)
¹¹⁵ In	1097.30(20)d	87.3(17)	2.30[30%]
¹¹⁵ In	1293.54(15)d	131(3)	3.46[30%]
¹¹⁵ In	1507.40(20)d	15.5(5)	0.409[30%]
¹¹⁵ In	1753.8(6)d	3.82(12)	0.101[30%]
¹¹⁵ In	2112.1(4)d	24.1(7)	0.636[30%]
¹¹⁵ In	5333.54(18)	0.89(7)	0.0235(18)
¹¹⁵ In	5347.4(6)	0.362(25)	0.0096(7)
¹¹⁵ In	5358.9(5)	0.51(4)	0.0135(11)
¹¹⁵ In	5410.56(19)	0.53(4)	0.0140(11)
¹¹⁵ In	5891.89(17)	2.10(14)	0.055(4)
Tin (Z=50), At.Wt.=118.710(7), σ_γ^z=0.54(5)			
¹²⁰ Sn	60.66(15)	0.0052(7)	1.33(18)E-4
¹²² Sn	125.80(7)	0.00178(9)	4.54(23)E-5
¹¹⁶ Sn	158.65(6)	0.0145(3)	0.000370(8)
¹²⁴ Sn	187.67(7)	0.00363(12)	9.3(3)E-5
¹²⁴ Sn	331.90(20)d	0.00830(20)	2.12E-4[77%]
¹¹⁵ Sn	416.99(4)	0.00251(11)	6.4(3)E-5
¹¹⁵ Sn	463.242(17)	0.0128(3)	0.000327(8)
¹¹⁷ Sn	528.85(6)	0.00425(14)	1.08(4)E-4
¹¹⁶ Sn	552.90(9)	0.00137(13)	3.5(3)E-5
¹¹⁹ Sn	703.87(7)	0.0078(3)	1.99(8)E-4
¹¹⁵ Sn	733.89(3)	0.00925(21)	2.36(5)E-4
¹¹⁷ Sn	813.26(7)	0.0071(3)	1.81(8)E-4
¹¹⁵ Sn	818.721(14)	0.0128(4)	0.000327(10)
¹¹⁷ Sn	827.37(8)	0.00361(23)	9.2(6)E-5
¹¹⁶ Sn	861.39(10)	0.00191(19)	4.9(5)E-5
¹²⁰ Sn	869.38(8)	0.00320(22)	8.2(6)E-5
¹¹⁸ Sn	897.28(8)	0.00368(21)	9.4(5)E-5
¹²⁰ Sn	908.89(8)	0.00307(19)	7.8(5)E-5
¹²² Sn	920.87(7)	0.00404(21)	1.03(5)E-4
¹¹⁸ Sn	920.87(7)	0.00404(21)	1.03(5)E-4
¹¹⁹ Sn	925.90(6)	0.0097(3)	2.48(8)E-4
¹²⁰ Sn	925.90(6)	0.0097(3)	2.48(8)E-4
¹¹⁵ Sn	931.819(23)	0.0111(3)	0.000283(8)
¹²⁰ Sn	943.20(12)	0.00150(17)	3.8(4)E-5
¹¹⁵ Sn	972.619(17)	0.0158(5)	0.000403(13)
¹¹⁹ Sn	988.67(7)	0.00668(22)	1.71(6)E-4
¹¹⁶ Sn	1004.49(8)	0.00388(18)	9.9(5)E-5
¹²⁰ Sn	1041.60(14)	0.00189(20)	4.8(5)E-5
¹¹⁷ Sn	1050.66(9)	0.00293(22)	7.5(6)E-5
¹¹⁸ Sn	1065.17(13)	0.00214(21)	5.5(5)E-5
¹¹⁷ Sn	1095.18(10)	0.0067(3)	1.71(8)E-4
¹¹⁵ Sn	1097.323(18)	0.0039(5)	9.96(13)E-5
¹²⁰ Sn	1101.25(16)	0.00322(25)	8.2(6)E-5
¹¹⁵ Sn	1115.15(4)	0.00150(16)	3.8(4)E-5
¹¹⁵ Sn	1118.95(5)	0.00155(22)	4.0(6)E-5
¹¹⁹ Sn	1171.28(6)	0.0879(13)	0.00224(3)

^A Z	E _γ -keV	σ _γ ^z (E _γ)-barns	k ₀
¹¹⁷ Sn	1173.66(8)	0.0050(3)	1.28(8)E-4
¹¹⁹ Sn	1184.19(8)	0.0051(3)	1.30(8)E-4
¹¹⁵ Sn	1200.56(12)	0.00163(22)	4.2(6)E-5
¹¹⁵ Sn	1202.70(12)	0.0022(3)	5.6(8)E-5
¹¹⁷ Sn	1229.64(6)	0.0673(13)	0.00172(3)
¹¹⁸ Sn	1249.62(7)	0.0052(3)	1.33(8)E-4
¹¹⁵ Sn	1252.119(23)	0.00348(19)	8.9(5)E-5
¹¹⁵ Sn	1291.99(3)	0.0050(10)	1.3(3)E-4
¹¹⁵ Sn	1293.591(15)	0.1340(21)	0.00342(5)
¹¹⁵ Sn	1356.846(20)	0.0075(3)	1.91(8)E-4
¹¹⁹ Sn	1415.76(10)	0.00291(19)	7.4(5)E-5
¹¹⁷ Sn	1447.09(14)	0.00212(21)	5.4(5)E-5
¹¹⁷ Sn	1508.43(11)	0.0058(3)	1.48(8)E-4
¹¹⁵ Sn	1546.40(6)	0.00140(15)	3.6(4)E-5
¹¹⁵ Sn	1550.71(18)	0.00170(16)	4.3(4)E-5
¹¹⁵ Sn	1650.72(6)	0.0021(3)	5.4(8)E-5
¹¹⁸ Sn	1695.0(3)	0.00138(22)	3.5(6)E-5
¹¹⁵ Sn	1702.67(3)	0.00169(17)	4.3(4)E-5
¹¹⁵ Sn	1711.17(7)	0.00151(19)	3.9(5)E-5
¹¹⁵ Sn	1886.09(7)	0.0026(3)	6.6(8)E-5
¹¹⁵ Sn	1900.72(5)	0.0025(3)	6.4(8)E-5
¹¹⁵ Sn	1926.02(19)	0.0014(6)	3.6(15)E-5
¹¹⁵ Sn	1934.93(18)	0.0027(4)	6.9(10)E-5
¹¹⁵ Sn	1975.73(18)	0.0016(3)	4.1(8)E-5
¹¹⁷ Sn	2042.74(10)	0.0067(4)	1.71(10)E-4
¹¹⁵ Sn	2050.76(5)	0.0025(4)	6.4(10)E-5
¹¹⁵ Sn	2077.80(8)	0.0016(6)	4.1(15)E-5
¹¹⁹ Sn	2097.01(9)	0.0048(3)	1.23(8)E-4
¹¹⁵ Sn	2112.302(16)	0.0152(5)	0.000388(13)
¹¹⁵ Sn	2148.03(5)	0.0021(4)	5.4(10)E-5
¹¹⁵ Sn	2211.69(8)	0.0018(6)	4.6(15)E-5
¹¹⁵ Sn	2220.00(23)	0.0019(5)	4.9(13)E-5
¹¹⁵ Sn	2225.40(3)	0.0082(5)	2.09(13)E-4
¹¹⁵ Sn	2244.19(6)	0.0029(10)	7(3)E-5
¹¹⁹ Sn	2355.3	1.80E-03	4.60E-05
¹¹⁹ Sn	2420.83(15)	0.0029(3)	7.4(8)E-5
¹¹⁵ Sn	2585.57(3)	0.0047(4)	1.20(10)E-4
¹¹⁷ Sn	2677.47(20)	0.0022(3)	5.6(8)E-5
¹¹⁵ Sn	2707.43(6)	0.0024(6)	6.1(15)E-5
¹¹⁷ Sn	2738.1	2.00E-03	5.10E-05
¹¹⁵ Sn	2843.82(5)	0.0032(4)	8.2(10)E-5
¹¹⁵ Sn	2907.53(18)	0.0027(5)	6.9(13)E-5
¹¹⁵ Sn	2960.03(4)	0.0023(3)	5.9(8)E-5
¹¹⁵ Sn	2985.00(25)	0.0025(8)	6.4(20)E-5
¹¹⁵ Sn	3088.55(5)	0.00184(19)	4.7(5)E-5
¹¹⁵ Sn	3330.6(4)	0.0016(5)	4.1(13)E-5
¹¹⁵ Sn	3333.75(5)	0.0061(5)	1.56(13)E-4
¹¹⁵ Sn	3658.30(17)	0.0022(4)	5.6(10)E-5
¹¹⁵ Sn	4013.00(11)	0.00169(16)	4.3(4)E-5
¹¹⁵ Sn	4392.56(8)	0.00148(16)	3.8(4)E-5
¹¹⁵ Sn	4695.80(8)	0.0031(3)	7.9(8)E-5
¹¹⁵ Sn	4780.1(4)	0.0048(5)	1.23(13)E-4
¹¹⁵ Sn	4809.43(9)	0.00165(16)	4.2(4)E-5
¹¹⁵ Sn	5173.5(7)	0.0016(4)	4.1(10)E-5
¹¹⁵ Sn	5361.91(6)	0.0043(4)	1.10(10)E-4
¹¹⁵ Sn	5423.57(11)	0.00188(21)	4.8(5)E-5
¹¹⁵ Sn	5449.51(5)	0.00191(19)	4.9(5)E-5
¹¹⁵ Sn	5562.35(6)	0.0021(5)	5.4(13)E-5
¹¹⁵ Sn	5904.65(6)	0.00223(17)	5.7(4)E-5
¹¹⁵ Sn	6229.57(6)	0.00159(16)	4.1(4)E-5
¹¹⁵ Sn	6335.30(12)	0.0023(3)	5.9(8)E-5
¹¹⁵ Sn	6335.89(5)	0.0014(3)	3.6(8)E-5
¹¹⁵ Sn	6603.27(4)	0.00168(19)	4.3(5)E-5
¹¹⁵ Sn	7450.97(3)	0.00137(14)	3.5(4)E-5
¹¹⁷ Sn	9327.5(11)	0.00204(20)	5.2(5)E-5
Antimony (Z=51), At.Wt.=121.760(1), σ_γ^z=5.13(12)			
¹²³ Sb	39.96	0.028(6)	0.00070(15)
¹²³ Sb	40.8040(10)	0.10(3)	0.0025(8)

^A Z	E _γ -keV	σ _γ ^Z (E _γ)-barns	k ₀
¹²³ Sb	44.0910(10)	0.016(3)	0.00040(8)
¹²¹ Sb	45.7330(10)	0.027(7)	0.00067(17)
¹²¹ Sb	45.8480(10)	0.0076(21)	1.9(5)E-4
¹²¹ Sb	46.8350(10)	0.0082(25)	2.0(6)E-4
¹²¹ Sb	61.4130(10)	0.75(18)	0.019(5)
¹²¹ Sb	67.5940(10)	0.0082(22)	2.0(6)E-4
¹²¹ Sb	71.4670(10)	0.095(22)	0.0024(6)
¹²¹ Sb	76.0590(10)	0.039(9)	0.00097(22)
¹²¹ Sb	78.0910(10)	0.48(11)	0.012(3)
¹²¹ Sb	86.7140(10)	0.0080(19)	2.0(5)E-4
¹²³ Sb	87.601	0.212(8)	0.00528(20)
¹²¹ Sb	88.2690(10)	0.083(19)	0.0021(5)
¹²³ Sb	88.3850(10)	0.0196(11)	0.00049(3)
¹²¹ Sb	101.5520(10)	0.028(6)	0.00070(15)
¹²³ Sb	103.6510(10)	0.063(5)	0.00157(12)
¹²¹ Sb	105.8160(10)	0.21(5)	0.0052(12)
¹²¹ Sb	113.8870(10)	0.014(3)	0.00035(8)
¹²¹ Sb	114.8680(10)	0.31(7)	0.0077(17)
¹²¹ Sb	115.4210(10)	0.0110(25)	0.00027(6)
¹²¹ Sb	121.4970(10)	0.40(9)	0.0100(22)
¹²¹ Sb	124.0290(10)	0.037(9)	0.00092(22)
¹²³ Sb	133.8390(10)	0.056(4)	0.00139(10)
¹²³ Sb	137.9190(10)	0.0207(10)	0.000515(25)
¹²¹ Sb	141.4390(10)	0.060(14)	0.0015(4)
¹²³ Sb	143.2080(10)	0.028(4)	0.00070(10)
¹²¹ Sb	148.238	0.26(6)	0.0065(15)
¹²¹ Sb	148.6540(10)	0.016(4)	0.00040(10)
¹²¹ Sb	149.9720(10)	0.013(3)	0.00032(8)
¹²¹ Sb	153.3850(10)	0.0085(11)	2.1(3)E-4
¹²³ Sb	155.1780(10)	0.081(9)	0.00202(22)
¹²¹ Sb	166.4510(10)	0.074(4)	0.00184(10)
¹²³ Sb	167.6050(10)	0.046(4)	0.00114(10)
¹²¹ Sb	173.7880(20)	0.0192(11)	0.00048(3)
¹²³ Sb	173.7990(10)	0.0171(9)	0.000426(22)
¹²¹ Sb	177.4070(10)	0.0085(20)	2.1(5)E-4
¹²¹ Sb	184.0480(10)	0.031(7)	0.00077(17)
¹²³ Sb	185.1190(10)	0.0116(17)	0.00029(4)
¹²¹ Sb	194.0850(10)	0.0534(18)	0.00133(5)
¹²¹ Sb	201.5950(10)	0.091(3)	0.00226(8)
¹²¹ Sb	204.5580(10)	0.0354(15)	0.00088(4)
¹²¹ Sb	217.4170(20)	0.0118(8)	0.000294(20)
¹²¹ Sb	229.7080(10)	0.021(5)	0.00052(12)
¹²¹ Sb	232.1880(10)	0.039(3)	0.00097(8)
¹²¹ Sb	233.1690(10)	0.0996(24)	0.00248(6)
¹²³ Sb	246.3260(20)	0.0586(21)	0.00146(5)
¹²³ Sb	252.841(3)	0.0468(24)	0.00116(6)
¹²¹ Sb	255.4980(10)	0.030(4)	0.00075(10)
¹²¹ Sb	256.2270(10)	0.019(6)	0.00047(15)
¹²¹ Sb	261.6790(10)	0.0087(16)	2.2(4)E-4
¹²³ Sb	265.629(6)	0.024(4)	0.00060(10)
¹²³ Sb	269.3960(20)	0.0093(25)	2.3(6)E-4
¹²¹ Sb	272.2670(10)	0.019(3)	0.00047(8)
¹²¹ Sb	274.0010(10)	0.031(6)	0.00077(15)
¹²³ Sb	275.2780(20)	0.0135(8)	0.000336(20)
¹²¹ Sb	275.4400(10)	0.0306(16)	0.00076(4)
¹²³ Sb	276.2670(20)	0.0095(5)	2.36(12)E-4
¹²¹ Sb	282.6500(10)	0.274(7)	0.00682(17)
¹²¹ Sb	286.5180(20)	0.034(3)	0.00085(8)
¹²³ Sb	288.0170(20)	0.018(6)	0.00045(15)
¹²³ Sb	313.938(3)	0.015(4)	0.00037(10)
¹²³ Sb	313.990(6)	0.0317(24)	0.00079(6)
¹²³ Sb	322.1140(20)	0.036(3)	0.00090(8)
¹²¹ Sb	330.555(3)	0.058(3)	0.00144(8)
¹²¹ Sb	331.3030(20)	0.011(3)	0.00027(8)
¹²³ Sb	331.4600(20)	0.048(3)	0.00119(8)
¹²¹ Sb	332.2860(10)	0.101(3)	0.00251(8)
¹²³ Sb	334.980(3)	0.028(3)	0.00070(8)
¹²³ Sb	338.2980(20)	0.0142(16)	0.00035(4)

^A Z	E _γ -keV	σ _γ ^Z (E _γ)-barns	k ₀
¹²³ Sb	351.567(3)	0.0344(20)	0.00086(5)
¹²¹ Sb	378.1380(20)	0.0500(18)	0.00124(5)
¹²³ Sb	384.533(3)	0.069(3)	0.00172(8)
¹²³ Sb	390.4960(20)	0.008(3)	2.0(8)E-4
¹²¹ Sb	392.3340(20)	0.0121(25)	0.00030(6)
¹²³ Sb	410.285(7)	0.0127(20)	0.00032(5)
¹²¹ Sb	418.8240(20)	0.013(3)	0.00032(8)
¹²¹ Sb	419.925(5)	0.064(7)	0.00159(17)
¹²¹ Sb	422.231(3)	0.022(5)	0.00055(12)
¹²¹ Sb	437.601(18)	0.0175(18)	0.00044(5)
¹²³ Sb	441.9270(20)	0.0101(7)	0.000251(17)
¹²¹ Sb	453.7470(20)	0.011(3)	0.00027(8)
¹²³ Sb	455.240(13)	0.0095(7)	2.36(17)E-4
¹²³ Sb	462.001(4)	0.0097(23)	2.4(6)E-4
¹²³ Sb	466.964(3)	0.0115(23)	0.00029(6)
¹²³ Sb	473.1350(20)	0.013(4)	0.00032(10)
¹²¹ Sb	485.35(4)	0.0212(21)	0.00053(5)
¹²¹ Sb	491.215(5)	0.0344(16)	0.00086(4)
¹²¹ Sb	501.034(3)	0.0076(21)	1.9(5)E-4
¹²³ Sb	501.151(4)	0.0129(10)	0.000321(25)
¹²¹ Sb	513.96(4)	0.0356(21)	0.00089(5)
¹²¹ Sb	542.304(17)	0.0267(20)	0.00066(5)
¹²¹ Sb	546.056(10)	0.0313(20)	0.00078(5)
¹²³ Sb	555.057(5)	0.021(5)	0.00052(12)
¹²¹ Sb	564.24(4)d	2.700(5)	0.06720[<0.1%]
¹²¹ Sb	564.4720(20)	0.0532(25)	0.00132(6)
¹²³ Sb	571.051(4)	0.0080(20)	2.0(5)E-4
¹²³ Sb	598.656(3)	0.055(4)	0.00137(10)
¹²¹ Sb	603.65(4)	0.019(3)	0.00047(8)
¹²¹ Sb	631.82(3)	0.0586(16)	0.00146(4)
¹²³ Sb	634.003(15)	0.0101(14)	0.00025(4)
¹²³ Sb	647.012(13)	0.0113(24)	0.00028(6)
¹²¹ Sb	692.65(4)d	0.146(5)	0.00363[<0.1%]
¹²³ Sb	695.372(13)	0.008(3)	2.0(8)E-4
¹²³ Sb	704.145(6)	0.009(3)	2.2(8)E-4
¹²¹ Sb	718.52(4)	0.015(6)	0.00037(15)
¹²³ Sb	723.49(3)	0.016(3)	0.00040(8)
¹²³ Sb	737.717(7)	0.012(3)	0.00030(8)
¹²¹ Sb	746.861(17)	0.030(3)	0.00075(8)
¹²³ Sb	763.44(3)	0.0169(24)	0.00042(6)
¹²³ Sb	768.364(6)	0.0114(24)	0.00028(6)
¹²³ Sb	775.395(7)	0.015(6)	0.00037(15)
¹²¹ Sb	796.61(4)	0.015(4)	0.00037(10)
¹²¹ Sb	824.952(17)	0.040(3)	0.00100(8)
¹²¹ Sb	842.91(7)	0.017(10)	0.00042(25)
¹²³ Sb	862.996(7)	0.009(4)	2.2(10)E-4
¹²¹ Sb	921.00(7)	0.075(4)	0.00187(10)
¹²³ Sb	972.024(17)	0.015(3)	0.00037(8)
¹²³ Sb	1020.942(10)	0.015(5)	0.00037(12)
¹²³ Sb	5224.99(24)	0.0083(23)	2.1(6)E-4
¹²³ Sb	5338.31(23)	0.0078(25)	1.9(6)E-4
¹²³ Sb	5407.83(6)	0.014(5)	0.00035(12)
¹²³ Sb	5446.51(5)	0.008(3)	2.0(8)E-4
¹²¹ Sb	5558.3(4)	0.0149(21)	0.00037(5)
¹²¹ Sb	5563.43(24)	0.0210(25)	0.00052(6)
¹²¹ Sb	5600.4(3)	0.016(3)	0.00040(8)
¹²³ Sb	5604.45(5)	0.012(3)	0.00030(8)
¹²¹ Sb	5619.2(4)	0.015(3)	0.00037(8)
¹²¹ Sb	5685.1(3)	0.0141(21)	0.00035(5)
¹²¹ Sb	5775.50(25)	0.011(7)	0.00027(17)
¹²¹ Sb	5787.62(25)	0.0093(17)	2.3(4)E-4
¹²¹ Sb	5800.65(24)	0.0107(19)	0.00027(5)
¹²³ Sb	5868.78(5)	0.034(4)	0.00085(10)
¹²¹ Sb	5885.19(9)	0.054(4)	0.00134(10)
¹²¹ Sb	6009.58(8)	0.020(3)	0.00050(8)
¹²³ Sb	6048.36(5)	0.018(3)	0.00045(8)
¹²³ Sb	6082.89(5)	0.018(3)	0.00045(8)
¹²¹ Sb	6163.62(7)	0.0121(18)	0.00030(5)

^A Z	E _γ -keV	σ _γ ^Z (E _γ)-barns	k ₀
¹²³ Sb	6335.72(5)	0.017(3)	0.00042(8)
¹²³ Sb	6363.76(5)	0.025(4)	0.00062(10)
¹²³ Sb	6379.80(5)	0.044(6)	0.00110(15)
¹²³ Sb	6456.54(5)	0.0077(20)	1.9(5)E-4
¹²³ Sb	6467.40(5)	0.021(4)	0.00052(10)
¹²¹ Sb	6494.91(7)	0.0076(24)	1.9(6)E-4
¹²¹ Sb	6523.52(7)	0.075(3)	0.00187(8)
¹²¹ Sb	6728.06(7)	0.044(4)	0.00110(10)
¹²¹ Sb	6744.74(7)	0.0090(16)	2.2(4)E-4
¹²¹ Sb	6806.15(7)	0.0102(11)	0.00025(3)
Tellurium (Z=52), At.Wt.=127.60(3), σ_γ^Z=4.6(4)			
¹³⁰ Te	149.716(5)d	0.0630(11)	0.00150[51%]
¹³⁰ Te	296.017(16)	0.029(3)	0.00069(7)
¹²³ Te	353.820(23)	0.100(8)	0.00237(19)
¹²² Te	440.04(4)	0.0100(14)	2.4(3)E-4
¹²⁴ Te	443.53(4)	0.030(3)	0.00071(7)
¹²³ Te	557.46(4)	0.038(4)	0.00090(10)
¹²³ Te	602.729(17)	2.46(16)	0.058(4)
¹²³ Te	645.819(20)	0.263(22)	0.0062(5)
¹²⁵ Te	666.3100(20)	0.045(5)	0.00107(12)
¹²³ Te	709.18(6)	0.026(3)	0.00062(7)
¹²³ Te	713.79(3)	0.058(5)	0.00138(12)
¹²³ Te	722.772(25)	0.52(4)	0.0123(10)
¹²³ Te	790.74(3)	0.025(4)	0.00059(10)
¹²³ Te	1054.51(4)	0.063(5)	0.00150(12)
¹²³ Te	1325.50(3)	0.074(6)	0.00176(14)
¹²³ Te	1355.00(6)	0.025(3)	0.00059(7)
¹²³ Te	1376.09(6)	0.039(4)	0.00093(10)
¹²³ Te	1436.55(3)	0.098(9)	0.00233(21)
¹²³ Te	1461.82(13)	0.028(7)	0.00066(17)
¹²³ Te	1488.88(5)	0.120(9)	0.00285(21)
¹²³ Te	1579.50(8)	0.072(10)	0.00171(24)
¹²³ Te	1691.06(6)	0.073(7)	0.00173(17)
¹²³ Te	1720.15(5)	0.083(8)	0.00197(19)
¹²⁴ Te	1851.37(10)	0.030(3)	0.00071(7)
¹²³ Te	1918.71(7)	0.047(4)	0.00112(10)
¹²³ Te	1998.24(7)	0.035(4)	0.00083(10)
¹²³ Te	2038.91(6)	0.064(7)	0.00152(17)
¹²³ Te	2078.76(9)	0.031(3)	0.00074(7)
¹²³ Te	2091.21(8)	0.031(3)	0.00074(7)
¹²³ Te	2144.20(5)	0.034(4)	0.00081(10)
¹²³ Te	2214.56(10)	0.027(3)	0.00064(7)
¹²³ Te	2385.57(5)	0.034(4)	0.00081(10)
¹²³ Te	2609.36(10)	0.039(4)	0.00093(10)
¹²³ Te	2746.92(5)	0.138(11)	0.0033(3)
¹²³ Te	2783.15(10)	0.035(3)	0.00083(7)
¹²³ Te	2974.83(14)	0.025(3)	0.00059(7)
¹²³ Te	3152.85(12)	0.026(3)	0.00062(7)
¹³⁰ Te	3347.35(10)	0.027(3)	0.00064(7)
¹²³ Te	3543.10(10)	0.039(4)	0.00093(10)
¹²⁸ Te	3721.75(12)	0.0209(21)	0.00050(5)
¹²³ Te	5668.13(13)	0.037(3)	0.00088(7)
¹²³ Te	5880.59(11)	0.034(4)	0.00081(10)
¹²³ Te	6211.61(12)	0.0262(25)	0.00062(6)
¹²⁶ Te	6287.6(4)	0.0023(7)	5.5(17)E-5
¹²³ Te	6322.95(8)	0.099(8)	0.00235(19)
¹²³ Te	7332.04(8)	0.027(4)	0.00064(10)
Iodine (Z=53), At.Wt.=126.90447(3), σ_γ^Z=6.20(20)			
¹²⁷ I	27.3620(10)	0.43(4)	0.0103(10)
¹²⁷ I	42.767(4)	0.038(5)	0.00091(12)
¹²⁷ I	52.385(3)	0.167(19)	0.0040(5)
¹²⁷ I	58.1100(20)	0.28(4)	0.0067(10)
¹²⁷ I	58.734(4)	0.028(3)	0.00067(7)
¹²⁷ I	67.120(3)	~0.1	~0.002
¹²⁷ I	68.256(4)	0.023(13)	0.0005(3)
¹²⁷ I	96.637(3)	0.0156(22)	0.00037(5)
¹²⁷ I	102.344(5)	0.0165(21)	0.00039(5)
¹²⁷ I	106.2490(10)	0.066(5)	0.00158(12)

^A Z	E _γ -keV	σ _γ ^Z (E _γ)-barns	k ₀
¹²⁷ I	124.2810(20)	0.180(13)	0.0043(3)
¹²⁷ I	126.989(3)	0.031(3)	0.00074(7)
¹²⁷ I	131.8640(20)	0.016(3)	0.00038(7)
¹²⁷ I	133.3940(10)	0.049(6)	0.00117(14)
¹²⁷ I	133.6110(10)	1.42(10)	0.0339(24)
¹²⁷ I	134.911(3)	0.015(11)	0.0004(3)
¹²⁷ I	142.1370(20)	0.140(14)	0.0033(3)
¹²⁷ I	144.025(3)	0.0157(24)	0.00037(6)
¹²⁷ I	147.105(3)	0.101(8)	0.00241(19)
¹²⁷ I	153.011(3)	0.209(14)	0.0050(3)
¹²⁷ I	156.5060(20)	0.116(10)	0.00277(24)
¹²⁷ I	160.7570(10)	0.187(16)	0.0045(4)
¹²⁷ I	164.1390(20)	0.040(4)	0.00096(10)
¹²⁷ I	193.5630(20)	0.124(12)	0.0030(3)
¹²⁷ I	205.412(3)	0.0227(20)	0.00054(5)
¹²⁷ I	224.098(3)	0.07(3)	0.0017(7)
¹²⁷ I	231.245(3)	0.017(4)	0.00041(10)
¹²⁷ I	235.900(4)	0.028(3)	0.00067(7)
¹²⁷ I	248.7410(20)	0.11(4)	0.0026(10)
¹²⁷ I	251.534(5)	0.025(3)	0.00060(7)
¹²⁷ I	255.517(5)	0.028(3)	0.00067(7)
¹²⁷ I	259.040(4)	0.0251(24)	0.00060(6)
¹²⁷ I	268.305(3)	0.080(8)	0.00191(19)
¹²⁷ I	282.611(12)	0.0193(20)	0.00046(5)
¹²⁷ I	283.968(4)	0.028(3)	0.00067(7)
¹²⁷ I	291.511(7)	0.0172(21)	0.00041(5)
¹²⁷ I	297.393(17)	0.0155(25)	0.00037(6)
¹²⁷ I	301.906(5)	0.17(6)	0.0041(14)
¹²⁷ I	310.419(6)	0.0166(18)	0.00040(4)
¹²⁷ I	314.349(4)	0.060(5)	0.00143(12)
¹²⁷ I	325.35(4)	0.020(3)	0.00048(7)
¹²⁷ I	330.801(5)	0.0146(21)	0.00035(5)
¹²⁷ I	344.758(7)	0.100(9)	0.00239(21)
¹²⁷ I	364.640(3)	0.0211(25)	0.00050(6)
¹²⁷ I	369.358(17)	0.0170(21)	0.00041(5)
¹²⁷ I	374.218(5)	0.041(7)	0.00098(17)
¹²⁷ I	374.456(7)	0.028(6)	0.00067(14)
¹²⁷ I	385.447(5)	0.086(7)	0.00205(17)
¹²⁷ I	388.911(5)	0.022(3)	0.00053(7)
¹²⁷ I	392.002(3)	0.045(14)	0.0011(3)
¹²⁷ I	392.687(6)	0.028(9)	0.00067(21)
¹²⁷ I	398.975(4)	0.018(3)	0.00043(7)
¹²⁷ I	416.579(6)	0.065(5)	0.00155(12)
¹²⁷ I	420.826(7)	0.139(18)	0.0033(4)
¹²⁷ I	442.901(10)d	0.595(4)	0.0140(1)
¹²⁷ I	458.056(9)	0.0266(23)	0.00064(6)
¹²⁷ I	502.607(18)	0.061(5)	0.00146(12)
¹²⁷ I	528.91(9)	0.054(5)	0.00129(12)
¹²⁷ I	557.43(4)	0.027(3)	0.00064(7)
¹²⁷ I	4950.10(7)	0.037(10)	0.00088(24)
¹²⁷ I	5018.648(17)	0.024(11)	0.0006(3)
¹²⁷ I	5091.988(12)	0.015(7)	0.00036(17)
¹²⁷ I	5096.357(17)	0.024(8)	0.00057(19)
¹²⁷ I	5197.957(12)	0.032(14)	0.0008(3)
¹²⁷ I	5298.245(12)	0.031(7)	0.00074(17)
¹²⁷ I	5463.453(12)	0.018(6)	0.00043(14)
¹²⁷ I	5482.853(12)	0.018(13)	0.0004(3)
¹²⁷ I	5524.28(5)	0.015(5)	0.00036(12)
¹²⁷ I	5559.662(12)	0.044(22)	0.0011(5)
¹²⁷ I	5574.501(12)	0.021(5)	0.00050(12)
¹²⁷ I	5725.929(12)	0.020(13)	0.0005(3)
¹²⁷ I	6307.586(6)	0.024(8)	0.00057(19)
¹²⁷ I	6692.417(5)	0.037(8)	0.00088(19)
Xenon (Z=54), At.Wt.=131.293(6), σ_γ^Z=24(3)			
¹³¹ Xe	324.80(16)	0.09(5)	0.0021(12)
¹²⁴ Xe	335.46(16)	0.0054(12)	1.2(3)E-4
¹²⁸ Xe	403.1(3)	0.0106(23)	2.4(5)E-4
¹³⁰ Xe	404.8(3)	0.0096(23)	2.2(5)E-4

^A Z	E _γ -keV	σ _γ ^Z (E _γ)-barns	k ₀	^A Z	E _γ -keV	σ _γ ^Z (E _γ)-barns	k ₀
¹³⁶ Xe	455.490(3)d	0.00350(6)	8.08E-5[91%]	¹³³ Cs	142.7680(20)	0.073(4)	0.00166(9)
¹³¹ Xe	471.72(12)	0.19(3)	0.0044(7)	¹³³ Cs	174.3040(20)	0.420(11)	0.00958(25)
¹³¹ Xe	483.66(10)	0.55(4)	0.0127(9)	¹³³ Cs	176.4040(20)	2.47(4)	0.0563(9)
¹³¹ Xe	505.84(8)	0.40(3)	0.0092(7)	¹³³ Cs	177.068(3)	0.098(16)	0.0022(4)
¹²⁹ Xe	510.33(8)	0.33(7)	0.0076(16)	¹³³ Cs	179.0180(20)	0.15(5)	0.0034(11)
¹³¹ Xe	522.78(7)	0.273(22)	0.0063(5)	¹³³ Cs	180.0770(20)	0.087(7)	0.00198(16)
¹²⁹ Xe	536.17(9)	1.71(24)	0.039(6)	¹³³ Cs	186.8400(20)	0.282(9)	0.00643(21)
¹³¹ Xe	546.95(11)	0.094(16)	0.0022(4)	¹³³ Cs	189.8320(20)	0.093(10)	0.00212(23)
¹³¹ Xe	570.13(7)	0.188(15)	0.0043(4)	¹³³ Cs	193.7250(20)	0.042(9)	0.00096(21)
¹²⁹ Xe	586.17(5)	0.48(7)	0.0111(16)	¹³³ Cs	194.724(3)	0.045(9)	0.00103(21)
¹³¹ Xe	600.19(8)	0.52(4)	0.0120(9)	¹³³ Cs	198.3010(20)	1.100(19)	0.0251(4)
¹³⁶ Xe	600.99(8)	0.010(3)	2.3(7)E-4	¹³³ Cs	200.847(4)	0.135(10)	0.00308(23)
¹³¹ Xe	621.13(10)	0.085(8)	0.00196(18)	¹³³ Cs	205.615(3)	1.560(25)	0.0356(6)
¹³¹ Xe	630.29(4)	1.41(11)	0.0325(25)	¹³³ Cs	207.675(4)	0.093(6)	0.00212(14)
¹³¹ Xe	667.79(6)	6.7(5)	0.155(12)	¹³³ Cs	209.5460(20)	0.073(6)	0.00166(14)
¹²⁹ Xe	668.59(15)	0.17(9)	0.0039(21)	¹³³ Cs	211.3190(10)	0.223(10)	0.00508(23)
¹³¹ Xe	670.02(10)	0.22(3)	0.0051(7)	¹³³ Cs	218.341(3)	0.309(9)	0.00705(21)
¹³¹ Xe	772.72(4)	1.78(14)	0.041(3)	¹³³ Cs	219.7530(20)	0.344(9)	0.00784(21)
¹³¹ Xe	812.45(10)	0.082(8)	0.00189(18)	¹³³ Cs	232.165(3)	0.125(9)	0.00285(21)
¹³¹ Xe	832.43(12)	0.108(15)	0.0025(4)	¹³³ Cs	234.3340(20)	1.070(23)	0.0244(5)
¹³¹ Xe	889.54(8)	0.084(8)	0.00194(18)	¹³³ Cs	245.8620(20)	0.740(15)	0.0169(3)
¹³¹ Xe	954.65(12)	0.076(8)	0.00175(18)	¹³³ Cs	254.740(3)	0.069(7)	0.00157(16)
¹³¹ Xe	984.54(9)	0.093(18)	0.0021(4)	¹³³ Cs	256.6210(20)	0.235(8)	0.00536(18)
¹³¹ Xe	1028.86(6)	0.40(3)	0.0092(7)	¹³³ Cs	261.1640(20)	0.401(11)	0.00914(25)
¹²⁹ Xe	1096.49(7)	0.087(12)	0.0020(3)	¹³³ Cs	263.8260(20)	0.079(7)	0.00180(16)
¹³¹ Xe	1115.34(9)	0.149(20)	0.0034(5)	¹³³ Cs	268.987(3)	0.199(6)	0.00454(14)
¹²⁹ Xe	1122.33(10)	0.119(17)	0.0027(4)	¹³³ Cs	271.3490(20)	0.127(15)	0.0029(3)
¹³¹ Xe	1136.13(7)	0.45(4)	0.0104(9)	¹³³ Cs	272.212(4)	0.069(12)	0.0016(3)
¹³¹ Xe	1140.84(11)	0.067(9)	0.00155(21)	¹³³ Cs	277.6310(20)	0.066(5)	0.00150(11)
¹³¹ Xe	1171.29(6)	0.217(19)	0.0050(4)	¹³³ Cs	279.648(3)	0.065(5)	0.00148(11)
¹³¹ Xe	1298.09(7)	0.12(3)	0.0028(7)	¹³³ Cs	284.987(3)	0.044(5)	0.00100(11)
¹³¹ Xe	1317.93(8)	0.89(7)	0.0205(16)	¹³³ Cs	293.295(3)	0.185(9)	0.00422(21)
¹²⁹ Xe	1482.06(9)	0.112(16)	0.0026(4)	¹³³ Cs	295.431(3)	0.231(10)	0.00527(23)
¹³¹ Xe	1519.83(8)	0.131(25)	0.0030(6)	¹³³ Cs	302.463(3)	0.13(4)	0.0030(9)
¹³¹ Xe	1801.58(6)	0.272(22)	0.0063(5)	¹³³ Cs	303.164(3)	0.055(6)	0.00125(14)
¹³¹ Xe	1888.05(8)	0.225(23)	0.0052(5)	¹³³ Cs	305.058(3)	0.061(7)	0.00139(16)
¹³¹ Xe	1985.71(10)	0.54(5)	0.0125(12)	¹³³ Cs	307.015(4)	1.45(3)	0.0331(7)
¹³¹ Xe	2713.93(10)	0.079(9)	0.00182(21)	¹³³ Cs	309.776(3)	0.237(9)	0.00540(21)
¹³¹ Xe	3699.40(15)	0.082(16)	0.0019(4)	¹³³ Cs	317.0720(20)	0.149(10)	0.00340(23)
¹³¹ Xe	4734.85(17)	0.071(10)	0.00164(23)	¹³³ Cs	329.060(3)	0.055(6)	0.00125(14)
¹³¹ Xe	4841.70(14)	0.107(15)	0.0025(4)	¹³³ Cs	338.027(6)	0.043(6)	0.00098(14)
¹³¹ Xe	5078.91(18)	0.106(16)	0.0024(4)	¹³³ Cs	345.358(5)	0.075(7)	0.00171(16)
¹²⁹ Xe	5956.18(18)	0.16(3)	0.0037(7)	¹³³ Cs	347.148(7)	0.073(6)	0.00166(14)
¹³¹ Xe	6380.62(13)	0.21(3)	0.0048(7)	¹³³ Cs	347.152(4)	0.030(4)	0.00068(9)
¹³¹ Xe	6467.09(12)	1.33(19)	0.031(4)	¹³³ Cs	349.846(3)	0.030(6)	0.00068(14)
Cesium (Z=55), At. Wt.=132.90545(2), σ_γ^Z=30.3(11)				¹³³ Cs	356.157(4)	0.445(12)	0.0101(3)
¹³³ Cs	11.2450(20)	0.142(7)	0.00324(16)	¹³³ Cs	356.345(3)	0.14(7)	0.0032(16)
¹³³ Cs	17.2130(20)	0.110(18)	0.0025(4)	¹³³ Cs	365.8570(20)	0.04(3)	0.0009(7)
¹³³ Cs	38.6240(20)	0.080(12)	0.0018(3)	¹³³ Cs	365.859(6)	0.103(6)	0.00235(14)
¹³³ Cs	48.790(20)	0.345(10)	0.00787(23)	¹³³ Cs	367.870(5)	0.173(8)	0.00394(18)
¹³³ Cs	60.0300(10)	0.443(14)	0.0101(3)	¹³³ Cs	371.7380(20)	0.131(7)	0.00299(16)
¹³³ Cs	67.2540(20)	0.088(5)	0.00201(11)	¹³³ Cs	377.311(5)	0.310(9)	0.00707(21)
¹³³ Cs	73.5660(20)	0.117(19)	0.0027(4)	¹³³ Cs	381.628(5)	0.066(7)	0.00150(16)
¹³³ Cs	74.0460(20)	0.14(3)	0.0032(7)	¹³³ Cs	384.290(5)	0.034(7)	0.00078(16)
¹³³ Cs	87.2520(20)	0.107(4)	0.00244(9)	¹³³ Cs	386.855(3)	0.163(9)	0.00372(21)
¹³³ Cs	93.1850(20)	0.043(3)	0.00098(7)	¹³³ Cs	391.3960(20)	0.080(7)	0.00182(16)
¹³³ Cs	113.7650(20)	0.777(15)	0.0177(3)	¹³³ Cs	393.535(5)	0.065(8)	0.00148(18)
¹³³ Cs	114.3270(20)	0.05(3)	0.0011(7)	¹³³ Cs	402.491(4)	0.051(10)	0.00116(23)
¹³³ Cs	116.3740(20)	1.39(12)	0.032(3)	¹³³ Cs	405.484(4)	0.079(12)	0.0018(3)
¹³³ Cs	116.612(4)	1.44(12)	0.033(3)	¹³³ Cs	408.483(7)	0.032(12)	0.0007(3)
¹³³ Cs	117.1730(20)	0.04(3)	0.0009(7)	¹³³ Cs	412.448(5)	0.051(13)	0.0012(3)
¹³³ Cs	118.3630(20)	0.230(7)	0.00524(16)	¹³³ Cs	417.277(4)	0.095(17)	0.0022(4)
¹³³ Cs	120.588(3)	0.414(10)	0.00944(23)	¹³³ Cs	421.052(5)	0.086(8)	0.00196(18)
¹³³ Cs	127.5000(20)d	0.310(11)	0.0071(3)	¹³³ Cs	422.491(6)	0.029(6)	0.00066(14)
¹³³ Cs	130.2320(20)	1.410(21)	0.0322(5)	¹³³ Cs	426.258(4)	0.041(7)	0.00093(16)
¹³³ Cs	131.171(3)	0.054(5)	0.00123(11)	¹³³ Cs	434.334(3)	0.066(7)	0.00150(16)
¹³³ Cs	133.5860(20)	0.038(3)	0.00087(7)	¹³³ Cs	438.9920(20)	0.140(9)	0.00319(21)
¹³³ Cs	137.7530(20)	0.030(4)	0.00068(9)	¹³³ Cs	442.8430(20)	0.316(12)	0.0072(3)

^A Z	E _γ -keV	σ _γ ^z (E _γ)-barns	k ₀
¹³³ Cs	444.465(7)	0.114(9)	0.00260(21)
¹³³ Cs	450.2370(20)	0.07(3)	0.0016(7)
¹³³ Cs	450.345(3)	0.99(5)	0.0226(11)
¹³³ Cs	451.4250(20)	0.058(10)	0.00132(23)
¹³³ Cs	454.0870(20)	0.056(11)	0.00128(25)
¹³³ Cs	458.357(6)	0.072(5)	0.00164(11)
¹³³ Cs	461.180(5)	0.099(5)	0.00226(11)
¹³³ Cs	464.481(4)	0.095(5)	0.00217(11)
¹³³ Cs	479.624(6)	0.030(10)	0.00068(23)
¹³³ Cs	485.038(3)	0.094(10)	0.00214(23)
¹³³ Cs	486.200(5)	0.08(3)	0.0018(7)
¹³³ Cs	487.388(4)	0.047(6)	0.00107(14)
¹³³ Cs	490.843(4)	0.042(10)	0.00096(23)
¹³³ Cs	495.593(3)	0.077(11)	0.00176(25)
¹³³ Cs	502.840(3)	0.256(13)	0.0058(3)
¹³³ Cs	508.077(3)	0.057(10)	0.00130(23)
¹³³ Cs	508.380(3)	0.053(10)	0.00121(23)
¹³³ Cs	510.795(3)	1.54(3)	0.0351(7)
¹³³ Cs	517.601(7)	0.028(21)	0.0006(5)
¹³³ Cs	519.101(4)	0.349(18)	0.0080(4)
¹³³ Cs	519.321(3)	0.086(14)	0.0020(3)
¹³³ Cs	524.1500(20)	0.151(23)	0.0034(5)
¹³³ Cs	525.356(4)	0.39(3)	0.0089(7)
¹³³ Cs	525.592(3)	0.13(6)	0.0030(14)
¹³³ Cs	526.072(4)	0.03(3)	0.0007(7)
¹³³ Cs	528.409(6)	0.08(3)	0.0018(7)
¹³³ Cs	529.504(6)	0.519(23)	0.0118(5)
¹³³ Cs	529.891(4)	~0.03	~0.0007
¹³³ Cs	539.180(4)	0.360(11)	0.00821(25)
¹³³ Cs	539.416(4)	0.18(7)	0.0041(16)
¹³³ Cs	540.679(9)	0.134(8)	0.00306(18)
¹³³ Cs	554.642(5)	0.206(9)	0.00470(21)
¹³³ Cs	559.084(3)	0.076(10)	0.00173(23)
¹³³ Cs	561.964(5)	0.130(10)	0.00296(23)
¹³³ Cs	564.019(4)	0.040(8)	0.00091(18)
¹³³ Cs	567.483(4)	0.052(9)	0.00119(21)
¹³³ Cs	570.825(3)	0.221(12)	0.0050(3)
¹³³ Cs	574.574(4)	0.061(12)	0.0014(3)
¹³³ Cs	576.060(4)	0.073(14)	0.0017(3)
¹³³ Cs	576.296(3)	0.038(21)	0.0009(5)
¹³³ Cs	579.131(4)	0.038(10)	0.00087(23)
¹³³ Cs	584.180(3)	0.027(14)	0.0006(3)
¹³³ Cs	591.680(5)	0.031(8)	0.00071(18)
¹³³ Cs	601.381(5)	0.080(9)	0.00182(21)
¹³³ Cs	601.775(5)	0.034(11)	0.00078(25)
¹³³ Cs	603.457(5)	0.061(8)	0.00139(18)
¹³³ Cs	610.896(4)	0.068(6)	0.00155(14)
¹³³ Cs	623.831(9)	0.055(8)	0.00125(18)
¹³³ Cs	628.595(4)	0.097(7)	0.00221(16)
¹³³ Cs	633.809(6)	0.112(7)	0.00255(16)
¹³³ Cs	645.453(5)	0.248(13)	0.0057(3)
¹³³ Cs	646.195(3)	0.064(11)	0.00146(25)
¹³³ Cs	648.511(4)	0.233(13)	0.0053(3)
¹³³ Cs	663.171(4)	0.155(9)	0.00353(21)
¹³³ Cs	663.407(3)	0.07(3)	0.0016(7)
¹³³ Cs	666.017(4)	0.089(8)	0.00203(18)
¹³³ Cs	678.271(5)	0.078(13)	0.0018(3)
¹³³ Cs	681.247(4)	0.110(24)	0.0025(6)
¹³³ Cs	682.562(4)	0.12(3)	0.0027(7)
¹³³ Cs	688.625(4)	0.058(10)	0.00132(23)
¹³³ Cs	691.434(5)	0.030(10)	0.00068(23)
¹³³ Cs	692.670(3)	0.037(6)	0.00084(14)
¹³³ Cs	695.340(6)	0.039(10)	0.00089(23)
¹³³ Cs	701.38(21)	0.036(10)	0.00082(23)
¹³³ Cs	703.290(5)	0.043(10)	0.00098(23)
¹³³ Cs	708.417(5)	0.220(11)	0.00502(25)
¹³³ Cs	708.646(4)	0.105(14)	0.0024(3)
¹³³ Cs	712.268(5)	0.113(9)	0.00258(21)

^A Z	E _γ -keV	σ _γ ^z (E _γ)-barns	k ₀
¹³³ Cs	722.343(5)	0.116(11)	0.00265(25)
¹³³ Cs	730.033(4)	0.045(8)	0.00103(18)
¹³³ Cs	741.277(4)	0.071(9)	0.00162(21)
¹³³ Cs	770.544(5)	0.104(11)	0.00237(25)
¹³³ Cs	799.668(4)	0.075(10)	0.00171(23)
¹³³ Cs	799.904(4)	0.029(6)	0.00066(14)
¹³³ Cs	814.739(6)	0.056(13)	0.0013(3)
¹³³ Cs	820.763(7)	0.059(11)	0.00135(25)
¹³³ Cs	852.574(5)	0.034(8)	0.00078(18)
¹³³ Cs	861.766(7)	0.070(9)	0.00160(21)
¹³³ Cs	868.99(10)	0.140(11)	0.00319(25)
¹³³ Cs	869.099(4)	0.140(11)	0.00319(25)
¹³³ Cs	880.343(4)	0.114(14)	0.0026(3)
¹³³ Cs	894.509(7)	0.103(12)	0.0023(3)
¹³³ Cs	894.808(7)	0.052(16)	0.0012(4)
¹³³ Cs	901.360(5)	0.053(11)	0.00121(25)
¹³³ Cs	904.288(4)	0.040(11)	0.00091(25)
¹³³ Cs	911.784(7)	0.177(14)	0.0040(3)
¹³³ Cs	912.021(7)	0.057(8)	0.00130(18)
¹³³ Cs	930.112(15)	0.126(9)	0.00287(21)
¹³³ Cs	931.72(15)	0.073(8)	0.00166(18)
¹³³ Cs	935.69(11)	0.130(9)	0.00296(21)
¹³³ Cs	966.454(5)	0.168(13)	0.0038(3)
¹³³ Cs	985.863(5)	0.078(12)	0.0018(3)
¹³³ Cs	986.100(5)	0.027(9)	0.00062(21)
¹³³ Cs	998.502(7)	0.103(11)	0.00235(25)
¹³³ Cs	1009.2(5)	0.05(3)	0.0011(7)
¹³³ Cs	1028.394(7)	0.038(15)	0.0009(3)
¹³³ Cs	1034.519(4)	0.028(8)	0.00064(18)
¹³³ Cs	1045.251(7)	0.120(11)	0.00274(25)
¹³³ Cs	1072.547(6)	0.066(19)	0.0015(4)
¹³³ Cs	1077.557(6)	0.209(12)	0.0048(3)
¹³³ Cs	1077.794(5)	0.088(12)	0.0020(3)
¹³³ Cs	1102.473(5)	0.047(8)	0.00107(18)
¹³³ Cs	1114.65(21)	0.049(10)	0.00112(23)
¹³³ Cs	1118.04(16)	0.069(9)	0.00157(21)
¹³³ Cs	1209.54(11)	0.138(11)	0.00315(25)
¹³³ Cs	5493.52(23)	0.230(19)	0.0052(4)
¹³³ Cs	5505.46(20)	0.333(22)	0.0076(5)
¹³³ Cs	5572.00(25)	0.249(20)	0.0057(5)
¹³³ Cs	5625.091(17)	0.111(13)	0.0025(3)
¹³³ Cs	5637.056(17)	0.277(21)	0.0063(5)
¹³³ Cs	5728.747(17)	0.087(16)	0.0020(4)
¹³³ Cs	5748.392(17)	0.146(15)	0.0033(3)
¹³³ Cs	5790.920(17)	0.137(13)	0.0031(3)
¹³³ Cs	5802.823(18)	0.120(13)	0.0027(3)
¹³³ Cs	5899.368(17)	0.116(12)	0.0026(3)
¹³³ Cs	5914.935(17)	0.047(8)	0.00107(18)
¹³³ Cs	5949.884(22)	0.045(10)	0.00103(23)
¹³³ Cs	5975.068(17)	0.027(10)	0.00062(23)
¹³³ Cs	5978.636(17)	0.099(14)	0.0023(3)
¹³³ Cs	6051.426(17)	0.240(20)	0.0055(5)
¹³³ Cs	6138.534(17)	0.061(8)	0.00139(18)
¹³³ Cs	6149.955(17)	0.038(6)	0.00087(14)
¹³³ Cs	6175.412(17)	0.252(16)	0.0057(4)
¹³³ Cs	6189.235(17)	0.191(14)	0.0044(3)
¹³³ Cs	6197.392(17)	0.035(8)	0.00080(18)
¹³³ Cs	6247.267(17)	0.038(6)	0.00087(14)
¹³³ Cs	6307.046(17)	0.044(10)	0.00100(23)
¹³³ Cs	6320.400(17)	0.050(8)	0.00114(18)
¹³³ Cs	6439.794(16)	0.082(8)	0.00187(18)
¹³³ Cs	6514.114(16)	0.044(7)	0.00100(16)
¹³³ Cs	6697.590(16)	0.224(17)	0.0051(4)
¹³³ Cs	6714.802(16)	0.090(11)	0.00205(25)
¹³³ Cs	6831.169(16)	0.035(4)	0.00080(9)
Barium (Z=56), At. Wt.=137.327(7), σ_γ^z=1.18(7)			
¹³⁵ Ba	66.32(16)	0.0067(6)	1.48(13)E-4
¹³⁵ Ba	87.08(13)	0.0093(6)	2.05(13)E-4

^A Z	E _γ -keV	σ _γ ^Z (E _γ)-barns	k ₀
¹³⁵ Ba	157.3(4)	0.0057(11)	1.26(24)E-4
¹³⁵ Ba	158.58(12)	0.0077(4)	1.70(9)E-4
¹³⁸ Ba	165.8570(10)d	0.074(8)	0.00163[21%]
¹³⁷ Ba	191.65(10)	0.0081(3)	1.79(7)E-4
¹³⁴ Ba	220.969(17)	0.0067(5)	1.48(11)E-4
¹³⁵ Ba	273.77(11)	0.0079(5)	1.74(11)E-4
¹³⁶ Ba	283.58(6)	0.0404(12)	0.00089(3)
¹³⁷ Ba	325.11(7)	0.00368(19)	8.1(4)E-5
¹³⁷ Ba	364.32(13)	0.00407(20)	9.0(4)E-5
¹³⁷ Ba	408.88(7)	0.0096(6)	2.12(13)E-4
¹³⁸ Ba	454.73(5)	0.0853(22)	0.00188(5)
¹³⁷ Ba	462.78(4)	0.0660(16)	0.00146(4)
¹³⁶ Ba	480.41(6)	0.00350(16)	7.7(4)E-5
¹³⁴ Ba	480.543(24)	0.00320(20)	7.1(4)E-5
¹³⁷ Ba	516.76(8)	0.0083(6)	1.83(13)E-4
¹³⁷ Ba	546.95(5)	0.00604(23)	1.33(5)E-4
¹³⁸ Ba	627.29(5)	0.294(6)	0.00649(13)
¹³⁸ Ba	665.98(9)	0.0053(3)	1.17(7)E-4
¹³⁵ Ba	671.60(9)	0.0045(3)	9.9(7)E-5
¹³⁵ Ba	732.49(7)	0.0238(8)	0.000525(18)
¹³⁵ Ba	746.6(4)	0.0031(3)	6.8(7)E-5
¹³⁷ Ba	754.03(7)	0.0067(3)	1.48(7)E-4
¹³⁵ Ba	760.31(11)	0.0073(5)	1.61(11)E-4
¹³⁵ Ba	818.514(12)	0.212(4)	0.00468(9)
¹³⁷ Ba	871.66(6)	0.0124(4)	0.000274(9)
¹³⁵ Ba	880.01(17)	0.0042(5)	9.3(11)E-5
¹³⁵ Ba	981.61(9)	0.0040(3)	8.8(7)E-5
¹³⁷ Ba	1009.73(5)	0.0167(5)	0.000369(11)
¹³⁷ Ba	1041.42(8)	0.00422(22)	9.3(5)E-5
¹³⁸ Ba	1047.73(6)	0.0319(10)	0.000704(22)
¹³⁵ Ba	1048.0730(20)	0.025(4)	0.00055(9)
¹³⁸ Ba	1103.43(8)	0.0044(4)	9.7(9)E-5
¹³⁷ Ba	1147.11(7)	0.0150(5)	0.000331(11)
¹³⁵ Ba	1235.29(12)	0.0148(7)	0.000327(15)
¹³⁵ Ba	1261.52(7)	0.095(5)	0.00210(11)
¹³⁷ Ba	1264.54(10)	0.00352(22)	7.8(5)E-5
¹³⁵ Ba	1310.21(9)	0.0094(7)	2.07(15)E-4
¹³⁷ Ba	1343.53(8)	0.0087(4)	1.92(9)E-4
¹³⁵ Ba	1404.08(9)	0.0051(5)	1.13(11)E-4
¹³⁴ Ba	1415.30(19)	0.0067(5)	1.48(11)E-4
¹³⁸ Ba	1420.41(9)	0.0090(5)	1.99(11)E-4
¹³⁷ Ba	1435.77(4)	0.308(7)	0.00680(15)
¹³⁷ Ba	1444.91(5)	0.0801(20)	0.00177(4)
¹³⁷ Ba	1495.58(9)	0.0104(7)	2.30(15)E-4
¹³⁵ Ba	1537.0(5)	0.0049(13)	1.1(3)E-4
¹³⁵ Ba	1551.01(6)	0.0231(9)	0.000510(20)
¹³⁷ Ba	1555.32(11)	0.00433(23)	9.6(5)E-5
¹³⁸ Ba	1558.16(8)	0.0078(5)	1.72(11)E-4
¹³⁵ Ba	1572.12(18)	0.0055(10)	1.21(22)E-4
¹³⁵ Ba	1581.46(6)	0.0096(7)	2.12(15)E-4
¹³⁷ Ba	1614.18(11)	0.015(7)	0.00033(15)
¹³⁷ Ba	1614.68(10)	0.0147(10)	0.000324(22)
¹³⁷ Ba	1619.88(15)	0.00328(24)	7.2(5)E-5
¹³⁵ Ba	1666.69(9)	0.0047(5)	1.04(11)E-4
¹³⁵ Ba	1714.09(9)	0.0076(12)	1.7(3)E-4
¹³⁷ Ba	1717.16(20)	0.0071(8)	1.57(18)E-4
¹³⁷ Ba	1727.32(10)	0.0056(4)	1.24(9)E-4
¹³⁷ Ba	1745.07(6)	0.0035(4)	7.7(9)E-5
¹³⁵ Ba	1842.90(11)	0.0054(7)	1.19(15)E-4
¹³⁸ Ba	1853.30(12)	0.0074(6)	1.63(13)E-4
¹³⁶ Ba	1898.68(5)	0.0305(10)	0.000673(22)
¹³⁸ Ba	1951.9(5)	0.009(6)	2.0(13)E-4
¹³⁵ Ba	1955.19(19)	0.0031(9)	6.8(20)E-5
¹³⁵ Ba	1993.15(16)	0.0044(11)	9.7(24)E-5
¹³⁷ Ba	2023.55(8)	0.0091(6)	2.01(13)E-4
¹³⁵ Ba	2080.04(5)	0.0074(5)	1.63(11)E-4
¹³⁵ Ba	2128.73(9)	0.0114(6)	0.000252(13)
¹³⁷ Ba	2207.85(5)	0.0038(6)	8.4(13)E-5

^A Z	E _γ -keV	σ _γ ^Z (E _γ)-barns	k ₀
¹³⁷ Ba	2210.82(16)	0.0038(8)	8.4(18)E-5
¹³⁷ Ba	2217.84(8)	0.044(5)	0.00097(11)
¹³⁸ Ba	2242.58(13)	0.0116(13)	0.00026(3)
¹³⁷ Ba	2401.96(15)	0.0031(3)	6.8(7)E-5
¹³⁵ Ba	2485.20(8)	0.00349(24)	7.7(5)E-5
¹³⁸ Ba	2537.72(10)	0.0102(7)	2.25(15)E-4
¹³⁸ Ba	2566.0(11)	0.009(5)	2.0(11)E-4
¹³⁷ Ba	2582.87(8)	0.0033(3)	7.3(7)E-5
¹³⁸ Ba	2593.42(11)	0.0187(8)	0.000413(18)
¹³⁷ Ba	2639.20(7)	0.0184(16)	0.00041(4)
¹³⁶ Ba	2662.66(5)	0.00401(16)	8.8(4)E-5
¹³⁷ Ba	2806.29(11)	0.0032(4)	7.1(9)E-5
¹³⁵ Ba	2976.64(17)	0.0181(7)	0.000399(15)
¹³⁵ Ba	3045.19(23)	0.00336(16)	7.4(4)E-5
¹³⁷ Ba	3049.93(12)	0.0037(3)	8.2(7)E-5
¹³⁷ Ba	3099.89(14)	0.0032(5)	7.1(11)E-5
¹³⁷ Ba	3338.60(10)	0.0090(5)	1.99(11)E-4
¹³⁵ Ba	3435.5(4)	0.0043(5)	9.5(11)E-5
¹³⁷ Ba	3503.94(17)	0.0046(4)	1.02(9)E-4
¹³⁸ Ba	3641.12(9)	0.0562(16)	0.00124(4)
¹³⁷ Ba	3643.59(3)	0.0033(17)	7(4)E-5
¹³⁴ Ba	3676.5(5)	0.0045(3)	9.9(7)E-5
¹³⁷ Ba	3739.50(12)	0.0042(5)	9.3(11)E-5
¹³⁷ Ba	3965.98(13)	0.00342(22)	7.5(5)E-5
¹³⁷ Ba	4025.52(14)	0.0038(4)	8.4(9)E-5
¹³⁷ Ba	4025.70(14)	0.0038(8)	8.4(18)E-5
¹³⁷ Ba	4083.64(16)	0.0067(6)	1.48(13)E-4
¹³⁸ Ba	4095.84(9)	0.155(4)	0.00342(9)
¹³⁷ Ba	4103.50(19)	0.0032(5)	7.1(11)E-5
¹³⁷ Ba	4114.45(19)	0.00329(24)	7.3(5)E-5
¹³⁷ Ba	4166.05(12)	0.0052(3)	1.15(7)E-4
¹³⁶ Ba	4242.98(8)	0.0087(10)	1.92(22)E-4
¹³⁷ Ba	4251.82(13)	0.0057(4)	1.26(9)E-4
¹³⁷ Ba	4279.55(14)	0.0039(5)	8.6(11)E-5
¹³⁷ Ba	4280.25(16)	0.0038(3)	8.4(7)E-5
¹³⁷ Ba	4288.15(14)	0.0059(3)	1.30(7)E-4
¹³⁷ Ba	4323.34(14)	0.0079(4)	1.74(9)E-4
¹³⁷ Ba	4331.24(16)	0.0091(12)	2.0(3)E-4
¹³⁷ Ba	4331.94(14)	0.0090(6)	1.99(13)E-4
¹³⁷ Ba	4369.47(10)	0.0069(5)	1.52(11)E-4
¹³⁷ Ba	4445.44(12)	0.0039(3)	8.6(7)E-5
¹³⁷ Ba	4597.95(22)	0.0044(4)	9.7(9)E-5
¹³⁷ Ba	4689.43(9)	0.0140(8)	0.000309(18)
¹³⁶ Ba	4723.38(8)	0.0264(8)	0.000583(18)
¹³⁷ Ba	4773.79(15)	0.0063(4)	1.39(9)E-4
¹³⁷ Ba	4967.90(6)	0.0098(7)	2.16(15)E-4
¹³⁷ Ba	5107.54(17)	0.0060(4)	1.32(9)E-4
¹³⁷ Ba	5272.88(10)	0.0088(10)	1.94(22)E-4
¹³⁵ Ba	5312.42(17)	0.0082(3)	1.81(7)E-4
¹³⁷ Ba	5448.42(11)	0.0053(6)	1.17(13)E-4
¹³⁷ Ba	5730.81(6)	0.0617(20)	0.00136(4)
¹³⁷ Ba	5972.26(9)	0.0044(3)	9.7(7)E-5
¹³⁷ Ba	6028.60(8)	0.0093(6)	2.05(13)E-4
¹³⁵ Ba	6062.37(23)	0.00516(14)	1.14(3)E-4
¹³⁷ Ba	6421.67(8)	0.00337(19)	7.4(4)E-5
¹³⁶ Ba	6621.99(8)	0.0034(6)	7.5(13)E-5
¹³⁵ Ba	8288.93(5)	0.00349(11)	7.70(24)E-5
¹³⁵ Ba	9107.41(4)	0.00635(23)	1.40(5)E-4
Lanthanum (Z=57), At. Wt.=138.9055(2), σ_γ^Z=9.08(4)			
¹³⁹ La	14.2380(20)	0.028(6)	0.00061(13)
¹³⁹ La	28.5330(10)	0.0103(11)	2.25(24)E-4
¹³⁹ La	29.9640(10)	0.169(8)	0.00369(17)
¹³⁹ La	34.6460(10)	0.0220(20)	0.00048(4)
¹³⁹ La	45.913(6)	0.0120(7)	0.000262(15)
¹³⁹ La	54.9440(10)	0.143(7)	0.00312(15)
¹³⁹ La	63.1790(10)	0.208(8)	0.00454(17)
¹³⁹ La	69.1830(20)	0.0137(5)	0.000299(11)
¹³⁹ La	132.695(3)	0.0146(6)	0.000319(13)

^A Z	E _γ -keV	σ _γ ^Z (E _γ)-barns	k ₀	^A Z	E _γ -keV	σ _γ ^Z (E _γ)-barns	k ₀
¹³⁹ La	155.560(5)	0.192(7)	0.00419(15)	¹³⁸ La	1215.72(22)	0.019(4)	0.00041(9)
¹³⁹ La	162.659(3)	0.489(18)	0.0107(4)	¹³⁸ La	1219.79(17)	0.026(4)	0.00057(9)
¹³⁸ La	166.04(7)	0.0119(12)	0.00026(3)	¹³⁸ La	1435.795(10)	0.539(7) s ⁻¹ g ⁻¹	Abundant
¹³⁹ La	169.392(10)	0.0382(14)	0.00083(3)	¹³⁸ La	1537.7(3)	0.009(3)	2.0(7)E-4
¹³⁹ La	209.127(4)	0.0431(16)	0.00094(4)	¹³⁹ La	1596.21(4)d	5.84(9)	0.1274[<0.1%]
¹³⁹ La	215.02(16)	0.025(6)	0.00055(13)	¹³⁹ La	2345.21(6)	0.0164(6)	0.000358(13)
¹³⁹ La	218.225(22)	0.78(3)	0.0170(7)	¹³⁹ La	2512.55(17)	0.0194(7)	0.000423(15)
¹³⁹ La	235.771(8)	0.111(4)	0.00242(9)	¹³⁹ La	2517.04(8)	0.0353(13)	0.00077(3)
¹³⁹ La	237.660(4)	0.320(12)	0.0070(3)	¹³⁹ La	2521.40(5)d	0.2120(23)	0.00463[<0.1%]
¹³⁹ La	255.040(5)	0.017(4)	0.00037(9)	¹³⁹ La	2532.39(4)	0.0188(7)	0.000410(15)
¹³⁹ La	258.875(22)	0.0233(9)	0.000508(20)	¹³⁹ La	2538.82(7)	0.0119(5)	0.000260(11)
¹³⁹ La	272.306(4)	0.502(19)	0.0110(4)	¹³⁹ La	2555.76(4)	0.0231(9)	0.000504(20)
¹³⁹ La	279.979(22)	0.0640(24)	0.00140(5)	¹³⁹ La	2561.85(3)	0.0259(10)	0.000565(22)
¹³⁹ La	283.617(16)	0.0409(15)	0.00089(3)	¹³⁹ La	2564.79(3)	0.0373(14)	0.00081(3)
¹³⁹ La	287.408(22)	0.013(4)	0.00028(9)	¹³⁹ La	2598.16(4)	0.0231(9)	0.000504(20)
¹³⁹ La	288.255(5)	0.73(3)	0.0159(7)	¹³⁹ La	2607.17(3)	0.0344(13)	0.00075(3)
¹³⁹ La	290.92(3)	0.0167(6)	0.000364(13)	¹³⁹ La	2611.6(3)	0.0086(3)	1.88(7)E-4
¹³⁹ La	305.04(8)	0.0147(6)	0.000321(13)	¹³⁹ La	2617.76(4)	0.0149(6)	0.000325(13)
¹³⁹ La	310.14(3)	0.0184(7)	0.000401(15)	¹³⁹ La	2637.97(6)	0.0084(5)	1.83(11)E-4
¹³⁹ La	328.762(8)d	1.250(18)	0.0273[<0.1%]	¹³⁹ La	2640.00(3)	0.0160(6)	0.000349(13)
¹³⁹ La	329.727(12)	0.0140(5)	0.000305(11)	¹³⁹ La	2661.55(4)	0.0263(10)	0.000574(22)
¹³⁹ La	422.66(4)	0.370(14)	0.0081(3)	¹³⁹ La	2668.00(4)	0.0247(9)	0.000539(20)
¹³⁹ La	426.49(3)	0.0435(16)	0.00095(4)	¹³⁹ La	2677.63(12)	0.0100(4)	2.18(9)E-4
¹³⁹ La	432.493(12)d	0.1780(18)	0.00388[<0.1%]	¹³⁹ La	2688.09(3)	0.0254(10)	0.000554(22)
¹³⁹ La	478.05(5)	0.0407(15)	0.00089(3)	¹³⁹ La	2692.30(6)	0.0115(7)	0.000251(15)
¹³⁹ La	487.021(12)d	2.79(4)	0.0609[<0.1%]	¹³⁹ La	2698.19(4)	0.0185(7)	0.000404(15)
¹³⁹ La	495.620(13)	0.081(3)	0.00177(7)	¹³⁹ La	2702.38(6)	0.0109(4)	2.38(9)E-4
¹³⁹ La	528.34(11)	0.0197(7)	0.000430(15)	¹³⁹ La	2710.62(4)	0.0117(4)	0.000255(9)
¹³⁹ La	538.854(12)	0.0455(17)	0.00099(4)	¹³⁹ La	2714.63(3)	0.0141(5)	0.000308(11)
¹³⁹ La	549.01(3)	0.098(4)	0.00214(9)	¹³⁹ La	2724.26(4)	0.0151(6)	0.000329(13)
¹³⁹ La	553.148(12)	0.0602(23)	0.00131(5)	¹³⁹ La	2735.13(4)	0.0188(7)	0.000410(15)
¹³⁹ La	567.386(12)	0.335(13)	0.0073(3)	¹³⁹ La	2739.00(4)	0.0200(8)	0.000436(17)
¹³⁹ La	592.05(18)	0.0128(5)	0.000279(11)	¹³⁹ La	2747.65(4)	0.0198(8)	0.000432(17)
¹³⁹ La	595.099(12)	0.103(4)	0.00225(9)	¹³⁹ La	2757.726(24)	0.0515(19)	0.00112(4)
¹³⁹ La	602.032(12)	0.0522(20)	0.00114(4)	¹³⁹ La	2764.51(4)	0.0289(11)	0.000631(24)
¹³⁹ La	623.632(12)	0.0517(20)	0.00113(4)	¹³⁹ La	2767.58(4)	0.0287(11)	0.000626(24)
¹³⁹ La	628.314(12)	0.0284(11)	0.000620(24)	¹³⁹ La	2799.65(6)	0.0109(4)	2.38(9)E-4
¹³⁹ La	640.88(3)	0.0534(20)	0.00117(4)	¹³⁹ La	2804.82(4)	0.0203(8)	0.000443(17)
¹³⁹ La	658.278(12)	0.103(4)	0.00225(9)	¹³⁹ La	2837.50(4)	0.0195(7)	0.000425(15)
¹³⁹ La	667.594(14)	0.0580(22)	0.00127(5)	¹³⁹ La	2852.55(4)	0.0139(5)	0.000303(11)
¹³⁹ La	708.244(14)	0.134(5)	0.00292(11)	¹³⁹ La	2863.06(3)	0.073(3)	0.00159(7)
¹³⁹ La	710.07(3)	0.0668(25)	0.00146(6)	¹³⁹ La	2880.60(6)	0.0101(4)	2.20(9)E-4
¹³⁹ La	711.222(20)	0.0164(6)	0.000358(13)	¹³⁹ La	2896.63(6)	0.0081(5)	1.77(11)E-4
¹³⁹ La	722.538(14)	0.212(8)	0.00463(17)	¹³⁹ La	2903.65(5)	0.0112(4)	2.44(9)E-4
¹³⁹ La	725.11(20)	0.0125(5)	0.000273(11)	¹³⁹ La	2913.16(4)	0.0124(5)	0.000271(11)
¹³⁹ La	736.777(14)	0.0388(15)	0.00085(3)	¹³⁹ La	2916.89(4)	0.0130(8)	0.000284(17)
¹³⁹ La	744.71(3)	0.010(4)	2.2(9)E-4	¹³⁹ La	2919.73(6)	0.0086(3)	1.88(7)E-4
¹³⁹ La	751.637(18)d	0.2650(23)	0.00578[<0.1%]	¹³⁹ La	2925.00(3)	0.0435(16)	0.00095(4)
¹³⁹ La	766.30(5)	0.0127(5)	0.000277(11)	¹³⁹ La	2961.34(4)	0.0262(10)	0.000572(22)
¹³⁹ La	782.733(20)	0.0396(15)	0.00086(3)	¹³⁹ La	2969.27(4)	0.0409(15)	0.00089(3)
¹³⁹ La	787.3(4)	0.008(4)	1.7(9)E-4	¹³⁹ La	2977.35(5)	0.0164(6)	0.000358(13)
¹³⁸ La	788.742	0.273(5) s ⁻¹ g ⁻¹	Abundant	¹³⁹ La	2985.02(6)	0.0100(4)	2.18(9)E-4
¹³⁹ La	796.27(5)	0.0162(6)	0.000353(13)	¹³⁹ La	2988.53(3)	0.0458(17)	0.00100(4)
¹³⁹ La	815.772(19)d	1.430(12)	0.0312[<0.1%]	¹³⁹ La	2998.36(5)	0.0136(5)	0.000297(11)
¹³⁹ La	848.99(3)	0.0290(11)	0.000633(24)	¹³⁹ La	3017.070(24)	0.0671(25)	0.00146(6)
¹³⁹ La	863.28(3)	0.0149(6)	0.000325(13)	¹³⁹ La	3031.27(4)	0.0330(12)	0.00072(3)
¹³⁹ La	867.846(20)d	0.337(4)	0.00735[<0.1%]	¹³⁹ La	3035.56(3)	0.0518(20)	0.00113(4)
¹³⁹ La	868.32(5)	0.0558(21)	0.00122(5)	¹³⁹ La	3040.94(4)	0.0294(11)	0.000641(24)
¹³⁹ La	882.21(3)	0.0343(13)	0.00075(3)	¹³⁹ La	3051.49(5)	0.0183(7)	0.000399(15)
¹³⁹ La	887.70(11)	0.0222(8)	0.000484(17)	¹³⁹ La	3057.66(6)	0.0194(7)	0.000423(15)
¹³⁹ La	919.550(23)d	0.1630(18)	0.00356[<0.1%]	¹³⁹ La	3078.80(6)	0.0130(5)	0.000284(11)
¹³⁹ La	925.189(21)d	0.422(4)	0.00921[<0.1%]	¹³⁹ La	3082.979(24)	0.140(5)	0.00305(11)
¹³⁹ La	941.79(17)	0.0236(9)	0.000515(20)	¹³⁹ La	3091.30(6)	0.0114(4)	2.49(9)E-4
¹³⁹ La	986.74(3)	0.008(4)	1.7(9)E-4	¹³⁹ La	3095.50(4)	0.0191(7)	0.000417(15)
¹³⁹ La	991.859(20)	0.0487(18)	0.00106(4)	¹³⁹ La	3112.38(3)	0.0320(12)	0.00070(3)
¹³⁹ La	1006.153(20)	0.0347(13)	0.00076(3)	¹³⁹ La	3115.94(3)	0.0176(7)	0.000384(15)
¹³⁹ La	1020.392(20)	0.0535(20)	0.00117(4)	¹³⁹ La	3119.05(4)	0.0118(8)	0.000257(17)
¹³⁹ La	1055.038(20)	0.015(5)	0.00033(11)	¹³⁹ La	3137.21(4)	0.0239(9)	0.000521(20)

^A Z	E _γ -keV	σ _γ ^Z (E _γ)-barns	k ₀
¹³⁹ La	3142.75(3)	0.0320(12)	0.00070(3)
¹³⁹ La	3155.06(6)	0.0090(3)	1.96(7)E-4
¹³⁹ La	3163.792(24)	0.0324(12)	0.00071(3)
¹³⁹ La	3174.77(4)	0.0135(5)	0.000295(11)
¹³⁹ La	3189.09(3)	0.0538(20)	0.00117(4)
¹³⁹ La	3197.52(6)	0.0213(8)	0.000465(17)
¹³⁹ La	3213.35(4)	0.0144(5)	0.000314(11)
¹³⁹ La	3219.80(3)	0.0300(11)	0.000655(24)
¹³⁹ La	3265.263(24)	0.0532(20)	0.00116(4)
¹³⁹ La	3281.248(24)	0.0506(19)	0.00110(4)
¹³⁹ La	3318.99(4)	0.0319(12)	0.00070(3)
¹³⁹ La	3341.48(4)	0.0090(5)	1.96(11)E-4
¹³⁹ La	3359.88(3)	0.0120(7)	0.000262(15)
¹³⁹ La	3383.39(3)	0.0242(9)	0.000528(20)
¹³⁹ La	3395.44(4)	0.0161(6)	0.000351(13)
¹³⁹ La	3404.81(4)	0.0171(6)	0.000373(13)
¹³⁹ La	3417.24(4)	0.0181(7)	0.000395(15)
¹³⁹ La	3424.29(3)	0.0232(14)	0.00051(3)
¹³⁹ La	3425.399(24)	0.058(3)	0.00127(7)
¹³⁹ La	3437.83(4)	0.0247(9)	0.000539(20)
¹³⁹ La	3442.20(3)	0.0410(15)	0.00089(3)
¹³⁹ La	3459.91(3)	0.0199(8)	0.000434(17)
¹³⁹ La	3477.14(3)	0.0444(17)	0.00097(4)
¹³⁹ La	3488.77(3)	0.0170(6)	0.000371(13)
¹³⁹ La	3564.87(4)	0.0130(5)	0.000284(11)
¹³⁹ La	3580.90(4)	0.0129(5)	0.000281(11)
¹³⁹ La	3596.45(4)	0.0157(6)	0.000343(13)
¹³⁹ La	3606.467(24)	0.0556(21)	0.00121(5)
¹³⁹ La	3610.026(24)	0.0548(21)	0.00120(5)
¹³⁹ La	3665.631(24)	0.135(5)	0.00295(11)
¹³⁹ La	3679.641(24)	0.139(5)	0.00303(11)
¹³⁹ La	3683.89(3)	0.0322(21)	0.00070(5)
¹³⁹ La	3691.35(3)	0.0350(13)	0.00076(3)
¹³⁹ La	3718.321(24)	0.0384(15)	0.00084(3)
¹³⁹ La	3727.700(24)	0.073(3)	0.00159(7)
¹³⁹ La	3735.30(4)	0.0170(6)	0.000371(13)
¹³⁹ La	3738.56(4)	0.0352(13)	0.00077(3)
¹³⁹ La	3744.87(4)	0.0234(9)	0.000511(20)
¹³⁹ La	3821.40(4)	0.0131(9)	0.000286(20)
¹³⁹ La	3900.979(24)	0.0531(20)	0.00116(4)
¹³⁹ La	3951.14(3)	0.0198(8)	0.000432(17)
¹³⁹ La	3973.56(4)	0.0120(5)	0.000262(11)
¹³⁹ La	4044.182(21)	0.0297(11)	0.000648(24)
¹³⁹ La	4060.007(20)	0.0297(11)	0.000648(24)
¹³⁹ La	4105.897(20)	0.0238(9)	0.000519(20)
¹³⁹ La	4125.31(3)	0.0183(7)	0.000399(15)
¹³⁹ La	4389.505(14)	0.255(10)	0.00556(22)
¹³⁹ La	4416.22(3)	0.247(9)	0.00539(20)
¹³⁹ La	4502.647(13)	0.164(6)	0.00358(13)
¹³⁹ La	4558.891(13)	0.0488(18)	0.00106(4)
¹³⁹ La	4842.695(7)	0.661(25)	0.0144(6)
¹³⁹ La	4888.606(7)	0.150(6)	0.00327(13)
¹³⁹ La	4998.250(6)	0.0145(8)	0.000316(17)
¹³⁹ La	5097.726(6)	0.68(3)	0.0148(7)
¹³⁹ La	5126.257(6)	0.114(4)	0.00249(9)
¹³⁹ La	5130.939(6)	0.0159(9)	0.000347(20)
¹³⁹ La	5160.902(6)	0.089(5)	0.00194(11)
Cerium (Z=58), At. Wt.=140.116(1), σ_γ^Z=0.635(18)			
¹³⁶ Ce	254.29(5)d	2.0(6)E-4	4.3E-6[1.0%]
¹³⁸ Ce	255.65(6)	0.0082(7)	1.77(15)E-4
¹⁴⁰ Ce	475.04(4)	0.082(7)	0.00177(15)
¹³⁶ Ce	513.7(4)	0.0021(5)	4.5(11)E-5
¹⁴⁰ Ce	661.99(5)	0.241(15)	0.0052(3)
¹⁴⁰ Ce	671.64(5)	0.0057(5)	1.23(11)E-4
¹⁴² Ce	737.43(7)	0.026(3)	0.00056(7)
¹⁴² Ce	765.97(5)	0.0145(12)	0.00031(3)
¹⁴² Ce	789.40(8)	0.0050(6)	1.08(13)E-4
¹⁴² Ce	808.35(6)	0.0102(9)	2.21(19)E-4

^A Z	E _γ -keV	σ _γ ^Z (E _γ)-barns	k ₀
¹⁴² Ce	820.07(8)	0.0026(3)	5.6(7)E-5
¹⁴² Ce	862.23(7)	0.0044(4)	9.5(9)E-5
¹⁴² Ce	915.03(7)	0.0086(11)	1.86(24)E-4
¹⁴² Ce	987.69(9)	0.0040(5)	8.7(11)E-5
¹⁴⁰ Ce	1052.58(5)	0.0051(5)	1.10(11)E-4
¹⁴² Ce	1107.66(5)	0.040(3)	0.00087(7)
¹⁴⁰ Ce	1146.68(4)	0.0096(9)	2.08(19)E-4
¹⁴² Ce	1153.97(5)	0.0146(12)	0.00032(3)
¹⁴² Ce	1165.71(8)	0.0040(4)	8.7(9)E-5
¹⁴⁰ Ce	1288.69(5)	0.0076(6)	1.64(13)E-4
¹⁴⁰ Ce	1331.63(7)	0.0058(5)	1.25(11)E-4
¹³⁸ Ce	1347.24(13)	0.0028(3)	6.1(7)E-5
¹⁴⁰ Ce	1385.74(6)	0.0060(6)	1.30(13)E-4
¹⁴⁰ Ce	1497.03(12)	0.0062(9)	1.34(19)E-4
¹⁴⁰ Ce	1527.61(6)	0.0027(3)	5.8(7)E-5
¹⁴² Ce	1587.90(11)	0.0028(3)	6.1(7)E-5
¹⁴⁰ Ce	1673.95(9)	0.0033(4)	7.1(9)E-5
¹⁴⁰ Ce	1747.90(7)	0.0078(7)	1.69(15)E-4
¹⁴⁰ Ce	1808.67(6)	0.0038(4)	8.2(9)E-5
¹⁴² Ce	2203.36(10)	0.0039(5)	8.4(11)E-5
¹⁴⁰ Ce	2905.37(7)	0.0058(5)	1.25(11)E-4
¹⁴² Ce	2931.94(14)	0.0029(3)	6.3(7)E-5
¹⁴⁰ Ce	3002.41(6)	0.0104(8)	2.25(17)E-4
¹⁴⁰ Ce	3018.24(7)	0.0114(10)	2.47(22)E-4
¹⁴⁰ Ce	3092.19(8)	0.0072(6)	1.56(13)E-4
¹⁴⁰ Ce	3238.52(6)	0.0066(6)	1.43(13)E-4
¹⁴⁰ Ce	3434.50(8)	0.0039(4)	8.4(9)E-5
¹⁴⁰ Ce	3619.46(5)	0.0095(8)	2.05(17)E-4
¹⁴² Ce	3990.70(15)	0.0038(4)	8.2(9)E-5
¹⁴² Ce	4282.22(12)	0.0037(4)	8.0(9)E-5
¹⁴⁰ Ce	4291.08(4)	0.053(4)	0.00115(9)
¹⁴² Ce	4336.46(8)	0.0251(20)	0.00054(4)
¹⁴⁰ Ce	4766.10(5)	0.113(8)	0.00244(17)
Praseodymium (Z=59), At. Wt.=140.90765(2), σ_γ^Z=11.5(3)			
¹⁴¹ Pr	32.276(3)	0.055(11)	0.00118(24)
¹⁴¹ Pr	54.5530(20)	0.022(4)	0.00047(9)
¹⁴¹ Pr	55.957(3)	0.014(3)	0.00030(7)
¹⁴¹ Pr	60.0630(20)	0.134(14)	0.0029(3)
¹⁴¹ Pr	64.5050(20)	0.137(6)	0.00295(13)
¹⁴¹ Pr	68.6110(20)	0.116(6)	0.00249(13)
¹⁴¹ Pr	84.998(3)	0.207(11)	0.00445(24)
¹⁴¹ Pr	86.37(7)	0.085(7)	0.00183(15)
¹⁴¹ Pr	104.570(3)	0.0397(13)	0.00085(3)
¹⁴¹ Pr	115.528(4)	0.0419(13)	0.00090(3)
¹⁴¹ Pr	124.5680(20)	0.0339(18)	0.00073(4)
¹⁴¹ Pr	126.8460(20)	0.307(15)	0.0066(3)
¹⁴¹ Pr	140.9050(20)	0.479(10)	0.01030(22)
¹⁴¹ Pr	153.28(3)	0.0135(7)	0.000290(15)
¹⁴¹ Pr	159.1230(20)	0.0122(7)	0.000262(15)
¹⁴¹ Pr	176.8630(20)	1.06(4)	0.0228(9)
¹⁴¹ Pr	182.786(4)	0.377(14)	0.0081(3)
¹⁴¹ Pr	185.62(7)	0.017(4)	0.00037(9)
¹⁴¹ Pr	187.85(5)	0.048(12)	0.0010(3)
¹⁴¹ Pr	200.526(4)	0.0379(12)	0.00082(3)
¹⁴¹ Pr	231.18(4)	0.0127(10)	0.000273(22)
¹⁴¹ Pr	251.53(4)	0.0172(19)	0.00037(4)
¹⁴¹ Pr	268.38(4)	0.0166(8)	0.000357(17)
¹⁴¹ Pr	294.87(3)	0.0275(18)	0.00059(4)
¹⁴¹ Pr	360.64(3)	0.0342(19)	0.00074(4)
¹⁴¹ Pr	403.976(24)	0.0322(14)	0.00069(3)
¹⁴¹ Pr	415.17(5)	0.0122(10)	0.000262(22)
¹⁴¹ Pr	460.16(4)	0.057(3)	0.00123(7)
¹⁴¹ Pr	508.78(4)	0.104(10)	0.00224(22)
¹⁴¹ Pr	528.219(23)	0.0579(19)	0.00125(4)
¹⁴¹ Pr	546.448(15)	0.148(4)	0.00318(9)
¹⁴¹ Pr	557.75(3)	0.15(4)	0.0032(9)
¹⁴¹ Pr	560.495(23)	0.150(7)	0.00323(15)
¹⁴¹ Pr	570.111(14)	0.112(5)	0.00241(11)

^A Z	E _γ -keV	σ _γ ^z (E _γ)-barns	k ₀
¹⁴¹ Pr	573.28(4)	0.12(3)	0.0026(7)
¹⁴¹ Pr	619.29(4)	0.152(4)	0.00327(9)
¹⁴¹ Pr	630.04(3)	0.16(6)	0.0034(13)
¹⁴¹ Pr	633.34(4)	0.113(4)	0.00243(9)
¹⁴¹ Pr	645.720(24)	0.311(7)	0.00669(15)
¹⁴¹ Pr	684.59(3)	0.098(22)	0.0021(5)
¹⁴¹ Pr	698.65(3)	0.22(6)	0.0047(13)
¹⁴¹ Pr	705.309(24)	0.0399(20)	0.00086(4)
¹⁴¹ Pr	718.014(24)	0.0435(21)	0.00094(5)
¹⁴¹ Pr	729.233(14)	0.0712(23)	0.00153(5)
¹⁴¹ Pr	737.65(7)	0.0396(17)	0.00085(4)
¹⁴¹ Pr	746.973(14)	0.146(4)	0.00314(9)
¹⁴¹ Pr	772.566(24)	0.044(16)	0.0009(3)
¹⁴¹ Pr	790.306(24)	0.051(3)	0.00110(7)
¹⁴¹ Pr	801.29(4)	0.10(3)	0.0022(7)
¹⁴¹ Pr	804.91(7)	0.0455(25)	0.00098(5)
¹⁴¹ Pr	822.65(7)	0.0179(15)	0.00038(3)
¹⁴¹ Pr	864.98(3)	0.14(3)	0.0030(7)
¹⁴¹ Pr	893.16(4)	0.053(3)	0.00114(7)
¹⁴¹ Pr	956.84(3)	0.091(7)	0.00196(15)
¹⁴¹ Pr	974.47(4)	0.076(22)	0.0016(5)
¹⁴¹ Pr	992.00(4)	0.138(10)	0.00297(22)
¹⁴¹ Pr	1006.361(22)	0.153(8)	0.00329(17)
¹⁴¹ Pr	1024.10(3)	0.048(3)	0.00103(7)
¹⁴¹ Pr	1102.51(4)	0.056(3)	0.00120(7)
¹⁴¹ Pr	1150.946(21)	0.141(5)	0.00303(11)
¹⁴¹ Pr	1575.6(5)d	0.426(12)	0.0092[1.8%]
¹⁴¹ Pr	3532.83(3)	0.026(3)	0.00056(7)
¹⁴¹ Pr	3535.33(3)	0.026(3)	0.00056(7)
¹⁴¹ Pr	3549.71(3)	0.0288(24)	0.00062(5)
¹⁴¹ Pr	3556.85(3)	0.0127(17)	0.00027(4)
¹⁴¹ Pr	3563.23(3)	0.0110(23)	2.4(5)E-4
¹⁴¹ Pr	3582.48(3)	0.0236(21)	0.00051(5)
¹⁴¹ Pr	3587.84(3)	0.0128(17)	0.00028(4)
¹⁴¹ Pr	3591.03(3)	0.0139(19)	0.00030(4)
¹⁴¹ Pr	3599.14(3)	0.0234(24)	0.00050(5)
¹⁴¹ Pr	3602.51(3)	0.054(3)	0.00116(7)
¹⁴¹ Pr	3620.02(3)	0.024(3)	0.00052(7)
¹⁴¹ Pr	3629.19(3)	0.020(4)	0.00043(9)
¹⁴¹ Pr	3645.82(3)	0.015(3)	0.00032(7)
¹⁴¹ Pr	3650.20(3)	0.061(3)	0.00131(7)
¹⁴¹ Pr	3651.73(3)	0.0127(8)	0.000273(17)
¹⁴¹ Pr	3654.47(3)	0.060(4)	0.00129(9)
¹⁴¹ Pr	3664.35(3)	0.0193(25)	0.00042(5)
¹⁴¹ Pr	3678.37(3)	0.034(3)	0.00073(7)
¹⁴¹ Pr	3690.27(3)	0.0107(19)	2.3(4)E-4
¹⁴¹ Pr	3713.73(3)	0.047(3)	0.00101(7)
¹⁴¹ Pr	3742.46(3)	0.0191(24)	0.00041(5)
¹⁴¹ Pr	3762.26(3)	0.0177(24)	0.00038(5)
¹⁴¹ Pr	3771.88(3)	0.023(3)	0.00049(7)
¹⁴¹ Pr	3776.46(3)	0.0117(8)	0.000252(17)
¹⁴¹ Pr	3790.37(3)	0.140(6)	0.00301(13)
¹⁴¹ Pr	3800.04(3)	0.0144(23)	0.00031(5)
¹⁴¹ Pr	3811.64(3)	0.0231(23)	0.00050(5)
¹⁴¹ Pr	3862.86(3)	0.0199(25)	0.00043(5)
¹⁴¹ Pr	3871.70(3)	0.0164(23)	0.00035(5)
¹⁴¹ Pr	3892.63(3)	0.039(3)	0.00084(7)
¹⁴¹ Pr	3902.50(3)	0.0117(20)	0.00025(4)
¹⁴¹ Pr	3911.07(3)	0.042(3)	0.00090(7)
¹⁴¹ Pr	3923.07(3)	0.023(3)	0.00049(7)
¹⁴¹ Pr	3941.19(3)	0.0153(25)	0.00033(5)
¹⁴¹ Pr	3947.09(3)	0.0169(23)	0.00036(5)
¹⁴¹ Pr	4000.97(3)	0.0187(24)	0.00040(5)
¹⁴¹ Pr	4012.20(3)	0.027(3)	0.00058(7)
¹⁴¹ Pr	4058.05(3)	0.0133(16)	0.00029(3)
¹⁴¹ Pr	4090.15(3)	0.0137(16)	0.00029(3)
¹⁴¹ Pr	4120.77(3)	0.0130(16)	0.00028(3)
¹⁴¹ Pr	4134.04(3)	0.0408(25)	0.00088(5)

^A Z	E _γ -keV	σ _γ ^z (E _γ)-barns	k ₀
¹⁴¹ Pr	4163.89(3)	0.035(3)	0.00075(7)
¹⁴¹ Pr	4177.00(3)	0.0387(25)	0.00083(5)
¹⁴¹ Pr	4252.14(3)	0.032(3)	0.00069(7)
¹⁴¹ Pr	4276.54(3)	0.044(4)	0.00095(9)
¹⁴¹ Pr	4325.50(3)	0.0124(17)	0.00027(4)
¹⁴¹ Pr	4347.62(3)	0.0166(18)	0.00036(4)
¹⁴¹ Pr	4372.53(3)	0.0269(22)	0.00058(5)
¹⁴¹ Pr	4440.54(3)	0.0252(20)	0.00054(4)
¹⁴¹ Pr	4449.26(3)	0.0228(19)	0.00049(4)
¹⁴¹ Pr	4496.44(3)	0.098(6)	0.00211(13)
¹⁴¹ Pr	4579.64(3)	0.0126(17)	0.00027(4)
¹⁴¹ Pr	4592.28(3)	0.0165(19)	0.00035(4)
¹⁴¹ Pr	4692.120(22)	0.291(10)	0.00626(22)
¹⁴¹ Pr	4722.82(4)	0.083(4)	0.00179(9)
¹⁴¹ Pr	4731.284(9)	0.0149(18)	0.00032(4)
¹⁴¹ Pr	4801.22(3)	0.140(8)	0.00301(17)
¹⁴¹ Pr	4864.91(4)	0.0112(16)	2.4(3)E-4
¹⁴¹ Pr	5020.41(7)	0.0135(17)	0.00029(4)
¹⁴¹ Pr	5052.750(24)	0.0329(21)	0.00071(5)
¹⁴¹ Pr	5096.081(15)	0.208(8)	0.00447(17)
¹⁴¹ Pr	5137.972(24)	0.098(4)	0.00211(9)
¹⁴¹ Pr	5140.72(3)	0.269(11)	0.00579(24)
¹⁴¹ Pr	5206.03(4)	0.033(3)	0.00071(7)
¹⁴¹ Pr	5666.170(6)	0.379(15)	0.0082(3)
¹⁴¹ Pr	5698.445(6)	0.0117(14)	0.00025(3)
¹⁴¹ Pr	5770.736(6)	0.0371(23)	0.00080(5)
¹⁴¹ Pr	5825.286(5)	0.040(3)	0.00086(7)
¹⁴¹ Pr	5843.026(5)	0.147(6)	0.00316(13)
Neodymium (Z=60), At. Wt.=144.24(3), σ_γ^z=49.5(12)			
¹⁴⁸ Nd	165.0870(10)	0.032(8)	0.00067(17)
¹⁵⁰ Nd	189.0530(10)	0.020(7)	0.00042(15)
¹⁴³ Nd	201.86(7)	0.343(23)	0.0072(5)
¹⁴⁸ Nd	211.309(7)d	0.0370(16)	0.00078[18%]
¹⁴⁶ Nd	314.675(4)	0.0280(24)	0.00059(5)
¹⁴³ Nd	426.73(5)	0.574(15)	0.0121(3)
¹⁴⁵ Nd	453.89(5)	3.03(8)	0.0637(17)
¹⁴³ Nd	476.82(5)	1.93(5)	0.0405(11)
¹⁴² Nd	563.87(3)	0.74(3)	0.0155(6)
¹⁴⁵ Nd	589.46(6)	0.97(4)	0.0204(8)
¹⁴³ Nd	618.062(19)	13.4(3)	0.282(6)
¹⁴³ Nd	696.499(10)	33.3(23)	0.70(5)
¹⁴⁵ Nd	735.85(9)	0.479(13)	0.0101(3)
¹⁴² Nd	742.106(22)	3.8(4)	0.080(8)
¹⁴³ Nd	778.58(4)	0.791(20)	0.0166(4)
¹⁴³ Nd	814.12(3)	4.98(12)	0.1046(25)
¹⁴³ Nd	834.9(5)	0.333(24)	0.0070(5)
¹⁴³ Nd	863.89(8)	1.07(4)	0.0225(8)
¹⁴³ Nd	864.301(10)	4.27(11)	0.0897(23)
¹⁴³ Nd	980.60(4)	1.21(3)	0.0254(6)
¹⁴³ Nd	1136.92(6)	0.669(18)	0.0141(4)
¹⁴³ Nd	1357.04(8)	0.337(9)	0.00708(19)
¹⁴³ Nd	1376.19(7)	0.751(20)	0.0158(4)
¹⁴³ Nd	1413.16(4)	1.90(5)	0.0399(11)
¹⁴³ Nd	1418.07(10)	0.353(11)	0.00742(23)
¹⁴³ Nd	1481.95(8)	0.608(21)	0.0128(4)
¹⁴³ Nd	1515.84(9)	0.455(13)	0.0096(3)
¹⁴³ Nd	1560.796(14)	0.404(11)	0.00849(23)
¹⁴³ Nd	1671.74(10)	0.97(8)	0.0204(17)
¹⁴³ Nd	1895.74(16)	0.387(12)	0.00813(25)
¹⁴⁴ Nd	4836.36(25)	0.32(3)	0.0067(6)
¹⁴² Nd	5381.19(7)	0.49(4)	0.0103(8)
¹⁴³ Nd	6255.99(17)	1.50(12)	0.0315(25)
¹⁴³ Nd	6502.22(17)	3.18(17)	0.067(4)
¹⁴⁵ Nd	7110.98(8)	0.368(11)	0.00773(23)
Samarium (Z=62), At. Wt.=150.36(3), σ_γ^z=5621(80)			
¹⁵⁴ Sm	104.320(5)d	1.43(4)	0.0288[55%]
¹⁵² Sm	127.297(3)	4.1(3)	0.083(6)
¹⁵⁰ Sm	167.77(5)	0.73(13)	0.015(3)

^A Z	E _γ -keV	σ _γ ^z (E _γ)-barns	k ₀
¹⁴⁹ Sm	333.97(4)	4790(60)	96.5(12)
¹⁴⁹ Sm	403.02(3)	85.2(16)	1.72(3)
¹⁴⁹ Sm	439.40(4)	2860(150)	58(3)
¹⁴⁹ Sm	485.95(7)	72(3)	1.45(6)
¹⁴⁹ Sm	505.51(3)	528(80)	10.6(16)
¹⁴⁷ Sm	550.10(9)	9.6(6)	0.193(12)
¹⁴⁹ Sm	584.27(3)	480(70)	9.7(14)
¹⁴⁹ Sm	675.83(3)	172(7)	3.47(14)
¹⁴⁹ Sm	712.20(3)	267(4)	5.38(8)
¹⁴⁹ Sm	731.20(4)	54(4)	1.09(8)
¹⁴⁹ Sm	737.44(4)	597(8)	12.03(16)
¹⁴⁹ Sm	748.13(4)	67.9(20)	1.37(4)
¹⁵⁴ Sm	819.880(5)	0.153(10)	0.00308(20)
¹⁴⁹ Sm	831.78(5)	62.7(17)	1.26(3)
¹⁴⁹ Sm	859.86(4)	88(4)	1.77(8)
¹⁴⁹ Sm	869.29(3)	119(6)	2.40(12)
¹⁴⁹ Sm	1165.76(5)	61(3)	1.23(6)
¹⁴⁹ Sm	1170.59(4)	230(10)	4.64(20)
¹⁴⁹ Sm	1177.3(4)	57(3)	1.15(6)
¹⁴⁹ Sm	1193.84(4)	106(3)	2.14(6)
¹⁴⁹ Sm	1247.04(8)	51(3)	1.03(6)
¹⁴⁹ Sm	1262.07(10)	62(5)	1.25(10)
¹⁴⁹ Sm	1321.95(7)	76(9)	1.53(18)
¹⁴⁹ Sm	1350.39(5)	94(12)	1.89(24)
Europium (Z=63), At.Wt.=151.964(1), σ_γ^z=4560(140)			
¹⁵¹ Eu	19.700(10)	59(30)	1.2(6)
¹⁵¹ Eu	48.31(17)	181(70)	3.6(14)
¹⁵¹ Eu	52.39(9)	55(3)	1.10(6)
¹⁵¹ Eu	65.1(3)	16(8)	0.32(16)
¹⁵³ Eu	68.23(9)	69(20)	1.4(4)
¹⁵³ Eu	71.24(12)	45(14)	0.9(3)
¹⁵¹ Eu	73.21(9)	106(22)	2.1(4)
¹⁵³ Eu	74.86(12)	43(12)	0.86(24)
¹⁵¹ Eu	77.23(4)	187(13)	3.7(3)
¹⁵¹ Eu	87.13(11)	29(3)	0.58(6)
¹⁵¹ Eu	88.31(12)	42(5)	0.84(10)
¹⁵¹ Eu	89.847(6)	1430(30)	28.5(6)
¹⁵¹ Eu	89.847(6)d	1.300(3)	0.02592[19%]
¹⁵¹ Eu	91.20(10)	20(10)	0.40(20)
¹⁵³ Eu	100.86(23)	24(5)	0.48(10)
¹⁵¹ Eu	103.34(13)	48(5)	0.96(10)
¹⁵³ Eu	106.57(14)	42(6)	0.84(12)
¹⁵¹ Eu	111.0(3)	22(6)	0.44(12)
¹⁵¹ Eu	113.1(3)	15(5)	0.30(10)
¹⁵¹ Eu	117.54(10)	14.7(22)	0.29(4)
¹⁵¹ Eu	121.71(11)	17.7(25)	0.35(5)
¹⁵¹ Eu	124.01(16)	25(3)	0.50(6)
¹⁵³ Eu	125.19(16)	25(3)	0.50(6)
¹⁵³ Eu	129.06(12)	14.7(16)	0.29(3)
¹⁵¹ Eu	132.71(10)	20.7(13)	0.41(3)
¹⁵¹ Eu	135.42(9)	27.8(14)	0.55(3)
¹⁵¹ Eu	140.19(9)	21(4)	0.42(8)
¹⁵¹ Eu	143.54(8)	43(3)	0.86(6)
¹⁵³ Eu	154.14(9)	22(3)	0.44(6)
¹⁵¹ Eu	167.01(13)	18.9(19)	0.38(4)
¹⁵¹ Eu	169.28(9)	54.8(22)	1.09(4)
¹⁵¹ Eu	171.95(9)	40(3)	0.80(6)
¹⁵³ Eu	179.83(13)	20(3)	0.40(6)
¹⁵¹ Eu	182.38(11)	23(3)	0.46(6)
¹⁵³ Eu	187.37(8)	31.2(14)	0.62(3)
¹⁵¹ Eu	190.96(11)	19.7(14)	0.39(3)
¹⁵¹ Eu	193.11(13)	28.3(20)	0.56(4)
¹⁵¹ Eu	199.12(10)	25.5(15)	0.51(3)
¹⁵¹ Eu	203.63(10)	18.4(14)	0.37(3)
¹⁵¹ Eu	206.53(8)	58.7(20)	1.17(4)
¹⁵¹ Eu	208.51(18)	16.1(21)	0.32(4)
¹⁵¹ Eu	221.30(8)	73(3)	1.46(6)
¹⁵¹ Eu	233.22(14)	15.9(23)	0.32(5)

^A Z	E _γ -keV	σ _γ ^z (E _γ)-barns	k ₀
¹⁵¹ Eu	244.88(24)	26.3(22)	0.52(4)
¹⁵¹ Eu	246.5(3)	15(3)	0.30(6)
¹⁵¹ Eu	260.66(9)	15.9(18)	0.32(4)
¹⁵¹ Eu	273.65(8)	17.3(12)	0.345(24)
¹⁵³ Eu	281.78(9)	20.4(8)	0.407(16)
¹⁵¹ Eu	285.10(9)	23.2(18)	0.46(4)
¹⁵³ Eu	299.83(8)	24.0(6)	0.479(12)
Gadolinium (Z=64), At.Wt.=157.25(3), σ_γ^z=48770(150)			
¹⁵⁷ Gd	79.5100(10)	4010(100)	77.3(19)
¹⁵⁴ Gd	86.5470(10)	0.57(9)	0.0110(17)
¹⁵⁵ Gd	88.9670(10)	1380(40)	26.6(8)
¹⁵² Gd	109.7600(10)	0.089(4)	0.00172(8)
¹⁵² Gd	181.931(4)	7200(300)	139(6)
¹⁵⁵ Gd	199.2130(10)	2020(60)	38.9(12)
¹⁵⁷ Gd	255.654(4)	350(19)	6.7(4)
¹⁵⁷ Gd	277.544(7)	493(12)	9.50(23)
¹⁵⁵ Gd	296.526(3)	187(5)	3.60(10)
¹⁶⁰ Gd	360.940(20)d	0.199(5)	0.00384[91%]
¹⁵⁷ Gd	528.024(8)	97(11)	1.87(21)
¹⁵⁷ Gd	539.608(5)	144(5)	2.78(10)
¹⁵⁷ Gd	595.728(7)	75(3)	1.45(6)
¹⁵⁷ Gd	606.400(8)	271(8)	5.22(15)
¹⁵⁵ Gd	626.275(8)	73(22)	1.4(4)
¹⁵⁷ Gd	637.474(12)	114(4)	2.20(8)
¹⁵⁷ Gd	675.43(3)	76(5)	1.46(10)
¹⁵⁷ Gd	688.892(11)	122(7)	2.35(13)
¹⁵⁷ Gd	743.066(21)	177(5)	3.41(10)
¹⁵⁷ Gd	750.109(10)	118(11)	2.27(21)
¹⁵⁷ Gd	768.37(3)	221(11)	4.26(21)
¹⁵⁷ Gd	780.174(10)	1010(22)	19.5(4)
¹⁵⁷ Gd	782.28(3)	134(5)	2.58(10)
¹⁵⁷ Gd	814.602(10)	89(8)	1.72(15)
¹⁵⁷ Gd	820.107(24)	118(7)	2.27(13)
¹⁵⁷ Gd	824.127(24)	133(8)	2.56(15)
¹⁵⁵ Gd	841.218(12)	80(24)	1.5(5)
¹⁵⁷ Gd	852.885(25)	194(5)	3.74(10)
¹⁵⁷ Gd	852.947(9)	202(30)	3.9(6)
¹⁵⁷ Gd	867.682(11)	83(4)	1.60(8)
¹⁵⁷ Gd	870.690(25)	127(19)	2.4(4)
¹⁵⁷ Gd	870.815(25)	434(11)	8.36(21)
¹⁵⁷ Gd	870.877(9)	216(40)	4.2(8)
¹⁵⁷ Gd	874.93(3)	151(5)	2.91(10)
¹⁵⁷ Gd	879.29(3)	139(5)	2.68(10)
¹⁵⁷ Gd	897.502(10)	1200(50)	23.1(10)
¹⁵⁷ Gd	897.611(10)	1090(50)	21.0(10)
¹⁵⁷ Gd	915.017(10)	394(10)	7.59(19)
¹⁵⁷ Gd	917.378(25)	262(16)	5.0(3)
¹⁵⁷ Gd	917.54(3)	268(7)	5.16(13)
¹⁵⁷ Gd	922.466(20)	98(8)	1.89(15)
¹⁵⁷ Gd	942.404(11)	120(11)	2.31(21)
¹⁵⁷ Gd	944.174(10)	3090(70)	59.5(13)
¹⁵⁷ Gd	953.067(21)	73(6)	1.41(12)
¹⁵⁷ Gd	954.296(10)	89(15)	1.7(3)
¹⁵⁵ Gd	959.774(12)	147(50)	2.8(10)
¹⁵⁷ Gd	960.082(11)	216(17)	4.2(3)
¹⁵⁵ Gd	960.553(14)	84(40)	1.6(8)
¹⁵⁷ Gd	962.104(10)	2050(130)	39.5(25)
¹⁵⁵ Gd	969.877(18)	172(50)	3.3(10)
¹⁵⁷ Gd	977.121(10)	1440(21)	27.8(4)
¹⁵⁵ Gd	987.908(21)	144(40)	2.8(8)
¹⁵⁷ Gd	998.398(9)	559(40)	10.8(8)
¹⁵⁷ Gd	1000.859(10)	93(4)	1.79(8)
¹⁵⁷ Gd	1004.058(9)	404(22)	7.8(4)
¹⁵⁷ Gd	1007.340(20)	105(4)	2.02(8)
¹⁵⁷ Gd	1010.19(3)	232(7)	4.47(13)
¹⁵⁷ Gd	1034.45(4)	142(5)	2.74(10)
¹⁵⁵ Gd	1040.430(12)	209(60)	4.0(12)
¹⁵⁵ Gd	1065.136(12)	410(120)	7.9(23)

^A Z	E _γ -keV	σ _γ ^Z (E _γ)-barns	k ₀
¹⁵⁵ Gd	1067.185(12)	160(50)	3.1(10)
¹⁵⁵ Gd	1079.25(3)	87(30)	1.7(6)
¹⁵⁷ Gd	1097.002(10)	662(15)	12.8(3)
¹⁵⁷ Gd	1107.612(9)	1830(40)	35.3(8)
¹⁵⁷ Gd	1116.624(12)	419(9)	8.07(17)
¹⁵⁷ Gd	1119.163(10)	1180(30)	22.7(6)
¹⁵⁷ Gd	1141.458(10)	530(30)	10.2(6)
¹⁵⁷ Gd	1145.225(9)	82(9)	1.58(17)
¹⁵⁵ Gd	1154.102(12)	290(170)	6(3)
¹⁵⁵ Gd	1158.986(12)	490(150)	9(3)
¹⁵⁵ Gd	1168.874(13)	140(40)	2.7(8)
¹⁵⁵ Gd	1174.058(13)	110(30)	2.1(6)
¹⁵⁷ Gd	1180.328(9)	223(21)	4.3(4)
¹⁵⁵ Gd	1180.36(4)	189(60)	3.6(12)
¹⁵⁷ Gd	1183.968(10)	958(60)	18.5(12)
¹⁵⁷ Gd	1185.988(9)	1600(90)	30.8(17)
¹⁵⁵ Gd	1187.120(21)	340(100)	6.6(19)
¹⁵⁷ Gd	1187.122(9)	1420(90)	27.4(17)
¹⁵⁷ Gd	1219.947(9)	242(12)	4.66(23)
¹⁵⁵ Gd	1222.349(12)	139(40)	2.7(8)
¹⁵⁵ Gd	1230.789(23)	390(120)	7.5(23)
¹⁵⁷ Gd	1237.625(9)	208(9)	4.01(17)
¹⁵⁵ Gd	1242.481(17)	204(60)	3.9(12)
¹⁵⁵ Gd	1250.637(21)	113(30)	2.2(6)
¹⁵⁷ Gd	1255.980(10)	109(4)	2.10(8)
¹⁵⁷ Gd	1259.837(9)	417(10)	8.04(19)
¹⁵⁷ Gd	1263.478(10)	641(15)	12.4(3)
¹⁵⁵ Gd	1277.508(18)	180(50)	3.5(10)
¹⁵⁷ Gd	1278.932(9)	228(12)	4.39(23)
¹⁵⁷ Gd	1301.093(9)	213(6)	4.10(12)
¹⁵⁷ Gd	1323.387(10)	641(16)	12.4(3)
¹⁵⁷ Gd	1327.154(9)	294(9)	5.67(17)
¹⁵⁵ Gd	1366.473(18)	97(30)	1.9(6)
¹⁵⁷ Gd	1372.805(10)	195(15)	3.8(3)
¹⁵⁷ Gd	1377.86(8)	87(5)	1.68(10)
¹⁵⁷ Gd	1405.877(10)	101(4)	1.95(8)
¹⁵⁷ Gd	1437.910(10)	276(10)	5.32(19)
¹⁵⁵ Gd	1449.849(21)	106(30)	2.0(6)
¹⁵⁷ Gd	1517.419(10)	219(18)	4.2(4)
¹⁵⁷ Gd	1530.279(12)	107(8)	2.06(15)
¹⁵⁷ Gd	1587.806(10)	105(4)	2.02(8)
¹⁵⁷ Gd	1663.561(11)	105(8)	2.02(15)
¹⁵⁵ Gd	1682.081(19)	108(30)	2.1(6)
¹⁵⁷ Gd	1692.30(6)	88(13)	1.70(25)
¹⁵⁷ Gd	1774.37(12)	122(40)	2.4(8)
¹⁵⁷ Gd	1781.711(10)	91(22)	1.8(4)
¹⁵⁷ Gd	1815.045(11)	92(20)	1.8(4)
¹⁵⁷ Gd	1856.41(3)	147(50)	2.8(10)
¹⁵⁷ Gd	1944.269(20)	181(24)	3.5(5)
¹⁵⁷ Gd	1956.29(12)	175(21)	3.4(4)
¹⁵⁵ Gd	1965.970(25)	80(25)	1.5(5)
¹⁵⁷ Gd	2023.778(20)	114(30)	2.2(6)
¹⁵⁷ Gd	2073.593(11)	84(7)	1.62(13)
¹⁵⁷ Gd	2180.474(22)	159(50)	3.1(10)
¹⁵⁷ Gd	2196.56(16)	120(12)	2.31(23)
¹⁵⁷ Gd	2203.51(11)	151(10)	2.91(19)
¹⁵⁷ Gd	2259.983(23)	92(6)	1.77(12)
¹⁵⁷ Gd	2314.82(12)	142(6)	2.74(12)
¹⁵⁷ Gd	2459.07(18)	75(6)	1.45(12)
¹⁵⁷ Gd	2515.41(20)	88(6)	1.70(12)
¹⁵⁷ Gd	2577.32(15)	100(6)	1.93(12)
¹⁵⁷ Gd	2617.93(16)	100(6)	1.93(12)
¹⁵⁷ Gd	2678.60(16)	101(20)	1.9(4)
¹⁵⁷ Gd	2702.34(14)	116(5)	2.24(10)
¹⁵⁷ Gd	2799.39(17)	87(7)	1.68(13)
¹⁵⁷ Gd	3520.6(3)	83(9)	1.60(17)
¹⁵⁷ Gd	3700.3(4)	99(17)	1.9(3)
¹⁵⁷ Gd	3989.3(4)	103(22)	2.0(4)

^A Z	E _γ -keV	σ _γ ^Z (E _γ)-barns	k ₀
¹⁵⁷ Gd	4058.48(18)	74(5)	1.43(10)
¹⁵⁷ Gd	4310.0(3)	76(5)	1.46(10)
¹⁵⁷ Gd	4925.25(13)	235(8)	4.53(15)
¹⁵⁷ Gd	5058.37(17)	105(5)	2.02(10)
¹⁵⁷ Gd	5179.16(16)	110(6)	2.12(12)
¹⁵⁷ Gd	5239.83(17)	83(10)	1.60(19)
¹⁵⁷ Gd	5250.2(4)	103(17)	2.0(3)
¹⁵⁷ Gd	5403.38(20)	120(5)	2.31(10)
¹⁵⁷ Gd	5542.93(12)	112(5)	2.16(10)
¹⁵⁷ Gd	5582.26(15)	155(6)	2.99(12)
¹⁵⁷ Gd	5592.95(21)	91(4)	1.75(8)
¹⁵⁷ Gd	5609.80(20)	75(4)	1.45(8)
¹⁵⁷ Gd	5661.19(16)	124(5)	2.39(10)
¹⁵⁷ Gd	5677.28(5)	138(15)	2.7(3)
¹⁵⁷ Gd	5784.15(5)	105(5)	2.02(10)
¹⁵⁷ Gd	5903.39(6)	457(14)	8.8(3)
¹⁵⁷ Gd	6419.82(5)	131(6)	2.52(12)
¹⁵⁷ Gd	6671.73(5)	83(4)	1.60(8)
¹⁵⁷ Gd	6750.11(5)	965(30)	18.6(6)
Terbium (Z=65), At. Wt.=158.92534(2), σ_γ^Z=23.3(4)			
¹⁵⁹ Tb	15.413(6)	0.071(12)	0.00135(23)
¹⁵⁹ Tb	29.0170(20)	0.21(4)	0.0040(8)
¹⁵⁹ Tb	32.652(3)	0.19(3)	0.0036(6)
¹⁵⁹ Tb	33.1590(10)	0.22(4)	0.0042(8)
¹⁵⁹ Tb	41.8900(10)	0.64(10)	0.0122(19)
¹⁵⁹ Tb	50.8690(10)	0.60(15)	0.011(3)
¹⁵⁹ Tb	54.1290(10)	0.60(15)	0.011(3)
¹⁵⁹ Tb	59.6430(10)	0.48(6)	0.0092(11)
¹⁵⁹ Tb	62.374(6)	0.052(15)	0.0010(3)
¹⁵⁹ Tb	63.6860(10)	1.46(16)	0.028(3)
¹⁵⁹ Tb	64.1100(20)	1.2(3)	0.023(6)
¹⁵⁹ Tb	64.8240(20)	0.13(4)	0.0025(8)
¹⁵⁹ Tb	68.413(3)	0.035(14)	0.0007(3)
¹⁵⁹ Tb	75.0500(10)	1.78(18)	0.034(3)
¹⁵⁹ Tb	75.7880(10)	0.14(4)	0.0027(8)
¹⁵⁹ Tb	78.137(7)	0.034(18)	0.0006(3)
¹⁵⁹ Tb	78.8670(10)	0.19(4)	0.0036(8)
¹⁵⁹ Tb	79.099(6)	0.43(6)	0.0082(11)
¹⁵⁹ Tb	83.8940(20)	0.050(10)	0.00095(19)
¹⁵⁹ Tb	87.7150(10)	0.160(19)	0.0031(4)
¹⁵⁹ Tb	89.4080(20)	0.21(3)	0.0040(6)
¹⁵⁹ Tb	92.7590(10)	0.052(16)	0.0010(3)
¹⁵⁹ Tb	93.3060(20)	0.218(25)	0.0042(5)
¹⁵⁹ Tb	94.0440(20)	0.052(14)	0.0010(3)
¹⁵⁹ Tb	94.829(3)	0.071(11)	0.00135(21)
¹⁵⁹ Tb	97.194(10)	0.024(8)	0.00046(15)
¹⁵⁹ Tb	97.503(3)	0.50(6)	0.0095(11)
¹⁵⁹ Tb	97.967(3)	0.077(19)	0.0015(4)
¹⁵⁹ Tb	101.0660(20)	0.023(5)	0.00044(10)
¹⁵⁹ Tb	104.0670(20)	0.15(3)	0.0029(6)
¹⁵⁹ Tb	108.943(5)	0.026(5)	0.00050(10)
¹⁵⁹ Tb	112.3730(20)	0.089(10)	0.00170(19)
¹⁵⁹ Tb	117.950(4)	0.028(5)	0.00053(10)
¹⁵⁹ Tb	131.058(5)	0.064(8)	0.00122(15)
¹⁵⁹ Tb	135.5970(20)	0.39(4)	0.0074(8)
¹⁵⁹ Tb	138.5840(10)	0.052(6)	0.00099(11)
¹⁵⁹ Tb	140.784(6)	0.107(12)	0.00204(23)
¹⁵⁹ Tb	150.603(3)	0.144(15)	0.0027(3)
¹⁵⁹ Tb	153.6870(20)	0.44(5)	0.0084(10)
¹⁵⁹ Tb	158.9430(20)	0.111(12)	0.00212(23)
¹⁵⁹ Tb	163.2420(20)	0.105(11)	0.00200(21)
¹⁵⁹ Tb	176.833(3)	0.070(9)	0.00133(17)
¹⁵⁹ Tb	178.674(5)	0.049(8)	0.00093(15)
¹⁵⁹ Tb	178.881(3)	0.42(8)	0.0080(15)
¹⁵⁹ Tb	179.832(7)	0.023(4)	0.00044(8)
¹⁵⁹ Tb	181.864(5)	0.072(13)	0.00137(25)
¹⁵⁹ Tb	184.456(5)	0.11(3)	0.0021(6)
¹⁵⁹ Tb	185.187(7)	0.094(17)	0.0018(3)

^A Z	E _γ -keV	σ _γ ^Z (E _γ)-barns	k ₀	^A Z	E _γ -keV	σ _γ ^Z (E _γ)-barns	k ₀
¹⁵⁹ Tb	193.431(4)	0.37(4)	0.0071(8)	¹⁵⁹ Tb	414.870(6)	0.132(24)	0.0025(5)
¹⁵⁹ Tb	209.738(6)	0.055(6)	0.00105(11)	¹⁵⁹ Tb	420.630(8)	0.092(12)	0.00175(23)
¹⁵⁹ Tb	215.026(6)	0.036(5)	0.00069(10)	¹⁵⁹ Tb	427.158(9)	0.147(17)	0.0028(3)
¹⁵⁹ Tb	221.029(6)	0.022(4)	0.00042(8)	¹⁵⁹ Tb	430.905(14)	0.023(4)	0.00044(8)
¹⁵⁹ Tb	228.252(11)	0.032(4)	0.00061(8)	¹⁵⁹ Tb	432.079(13)	0.021(8)	0.00040(15)
¹⁵⁹ Tb	234.724(7)	0.026(5)	0.00050(10)	¹⁵⁹ Tb	437.445(9)	0.077(16)	0.0015(3)
¹⁵⁹ Tb	236.094(6)	0.032(6)	0.00061(11)	¹⁵⁹ Tb	442.212(14)	0.077(12)	0.00147(23)
¹⁵⁹ Tb	238.653(7)	0.023(5)	0.00044(10)	¹⁵⁹ Tb	447.390(9)	0.10(3)	0.0019(6)
¹⁵⁹ Tb	241.809(5)	0.035(8)	0.00067(15)	¹⁵⁹ Tb	448.105(12)	0.054(10)	0.00103(19)
¹⁵⁹ Tb	242.548(5)	0.018(4)	0.00034(8)	¹⁵⁹Tb	451.617(10)	0.21(3)	0.0040(6)
¹⁵⁹Tb	242.973(12)	0.219(24)	0.0042(5)	¹⁵⁹ Tb	453.266(10)	0.033(12)	0.00063(23)
¹⁵⁹ Tb	243.277(6)	0.16(3)	0.0031(6)	¹⁵⁹ Tb	455.783(10)	0.029(12)	0.00055(23)
¹⁵⁹Tb	248.062(5)	0.30(3)	0.0057(6)	¹⁵⁹ Tb	459.519(10)	0.085(12)	0.00162(23)
¹⁵⁹ Tb	255.038(6)	0.112(16)	0.0021(3)	¹⁵⁹Tb	464.264(17)	0.192(21)	0.0037(4)
¹⁵⁹ Tb	255.927(6)	0.052(9)	0.00099(17)	¹⁵⁹ Tb	492.460(13)	0.024(6)	0.00046(11)
¹⁵⁹ Tb	257.541(4)	0.045(7)	0.00086(13)	¹⁵⁹ Tb	496.916(17)	0.041(9)	0.00078(17)
¹⁵⁹ Tb	258.565(9)	0.033(6)	0.00063(11)	¹⁵⁹ Tb	519.790(14)	0.059(13)	0.00113(25)
¹⁵⁹ Tb	262.964(11)	0.022(6)	0.00042(11)	¹⁵⁹ Tb	521.308(21)	0.046(12)	0.00088(23)
¹⁵⁹ Tb	264.989(5)	0.031(7)	0.00059(13)	¹⁵⁹ Tb	525.194(17)	0.080(17)	0.0015(3)
¹⁵⁹ Tb	270.762(7)	0.102(12)	0.00194(23)	¹⁵⁹Tb	525.933(17)	0.22(3)	0.0042(6)
¹⁵⁹ Tb	274.385(11)	0.021(4)	0.00040(8)	¹⁵⁹ Tb	529.054(10)	0.022(8)	0.00042(15)
¹⁵⁹ Tb	275.707(5)	0.124(14)	0.0024(3)	¹⁵⁹ Tb	530.981(24)	0.037(10)	0.00071(19)
¹⁵⁹ Tb	277.818(6)	0.093(11)	0.00177(21)	¹⁵⁹ Tb	532.689(21)	0.129(16)	0.0025(3)
¹⁵⁹ Tb	278.152(7)	0.025(6)	0.00048(11)	¹⁵⁹ Tb	532.733(9)	0.15(3)	0.0029(6)
¹⁵⁹ Tb	278.803(7)	0.083(11)	0.00158(21)	¹⁵⁹ Tb	542.840(21)	0.034(8)	0.00065(15)
¹⁵⁹ Tb	282.698(5)	0.049(8)	0.00093(15)	¹⁵⁹ Tb	544.922(10)	0.064(10)	0.00122(19)
¹⁵⁹ Tb	283.289(7)	0.052(9)	0.00099(17)	¹⁵⁹ Tb	545.661(10)	0.056(11)	0.00107(21)
¹⁵⁹ Tb	284.148(9)	0.087(11)	0.00166(21)	¹⁵⁹ Tb	554.509(6)	0.021(7)	0.00040(13)
¹⁵⁹ Tb	287.738(9)	0.029(5)	0.00055(10)	¹⁵⁹ Tb	585.575(17)	0.054(8)	0.00103(15)
¹⁵⁹ Tb	288.212(5)	0.126(14)	0.0024(3)	¹⁵⁹ Tb	598.656(14)	0.020(6)	0.00038(11)
¹⁵⁹ Tb	290.625(10)	0.052(7)	0.00099(13)	¹⁵⁹ Tb	600.206(24)	0.155(18)	0.0030(3)
¹⁵⁹ Tb	295.757(9)	0.062(8)	0.00118(15)	¹⁵⁹ Tb	611.513(24)	0.034(9)	0.00065(17)
¹⁵⁹ Tb	302.735(13)	0.086(10)	0.00164(19)	¹⁵⁹ Tb	625.994(21)	0.027(7)	0.00051(13)
¹⁵⁹ Tb	303.114(10)	0.042(8)	0.00080(15)	¹⁵⁹ Tb	634.737(24)	0.037(7)	0.00071(13)
¹⁵⁹ Tb	308.102(9)	0.056(8)	0.00107(15)	¹⁵⁹ Tb	5184.2(3)	0.023(9)	0.00044(17)
¹⁵⁹ Tb	310.470(5)	0.177(21)	0.0034(4)	¹⁵⁹ Tb	5199.9(3)	0.033(8)	0.00063(15)
¹⁵⁹ Tb	310.804(6)	0.019(5)	0.00036(10)	¹⁵⁹ Tb	5204.5(3)	0.040(9)	0.00076(17)
¹⁵⁹ Tb	315.857(5)	0.118(14)	0.0023(3)	¹⁵⁹ Tb	5225.0(3)	0.040(13)	0.00076(25)
¹⁵⁹ Tb	316.564(9)	0.027(5)	0.00051(10)	¹⁵⁹ Tb	5228.45(25)	0.052(12)	0.00099(23)
¹⁵⁹ Tb	317.597(5)	0.121(15)	0.0023(3)	¹⁵⁹ Tb	5238.1(3)	0.026(10)	0.00050(19)
¹⁵⁹ Tb	319.862(6)	0.132(15)	0.0025(3)	¹⁵⁹ Tb	5245.6(3)	0.061(13)	0.00116(25)
¹⁵⁹ Tb	323.809(6)	0.022(4)	0.00042(8)	¹⁵⁹ Tb	5250.2(3)	0.064(12)	0.00122(23)
¹⁵⁹Tb	339.487(5)	0.35(4)	0.0067(8)	¹⁵⁹ Tb	5259.2(3)	0.022(5)	0.00042(10)
¹⁵⁹ Tb	339.821(6)	0.040(9)	0.00076(17)	¹⁵⁹ Tb	5288.99(25)	0.027(7)	0.00051(13)
¹⁵⁹ Tb	340.780(6)	0.069(9)	0.00132(17)	¹⁵⁹ Tb	5306.9(3)	0.021(6)	0.00040(11)
¹⁵⁹ Tb	341.731(6)	0.089(15)	0.0017(3)	¹⁵⁹ Tb	5373.1(4)	0.024(5)	0.00046(10)
¹⁵⁹ Tb	345.581(8)	0.041(8)	0.00078(15)	¹⁵⁹ Tb	5461.09(25)	0.029(7)	0.00055(13)
¹⁵⁹ Tb	347.032(6)	0.020(4)	0.00038(8)	¹⁵⁹ Tb	5516.2(5)	0.019(7)	0.00036(13)
¹⁵⁹ Tb	348.924(13)	0.053(10)	0.00101(19)	¹⁵⁹ Tb	5524.2(3)	0.051(13)	0.00097(25)
¹⁵⁹ Tb	351.095(9)	0.176(22)	0.0034(4)	¹⁵⁹ Tb	5551.8(3)	0.029(5)	0.00055(10)
¹⁵⁹ Tb	352.027(10)	0.020(4)	0.00038(8)	¹⁵⁹ Tb	5607.07(7)	0.042(9)	0.00080(17)
¹⁵⁹ Tb	352.514(6)	0.160(21)	0.0031(4)	¹⁵⁹ Tb	5611.6(3)	0.025(5)	0.00048(10)
¹⁵⁹ Tb	356.224(10)	0.117(17)	0.0022(3)	¹⁵⁹ Tb	5661.8(5)	0.037(7)	0.00071(13)
¹⁵⁹Tb	357.748(5)	0.26(3)	0.0050(6)	¹⁵⁹ Tb	5682.5(3)	0.027(7)	0.00051(13)
¹⁵⁹ Tb	359.960(10)	0.048(9)	0.00092(17)	¹⁵⁹ Tb	5696.8(3)	0.034(6)	0.00065(11)
¹⁵⁹ Tb	361.680(14)	0.095(12)	0.00181(23)	¹⁵⁹ Tb	5710.36(7)	0.029(5)	0.00055(10)
¹⁵⁹ Tb	363.821(6)	0.120(15)	0.0023(3)	¹⁵⁹ Tb	5754.34(21)	0.031(8)	0.00059(15)
¹⁵⁹ Tb	370.320(7)	0.057(7)	0.00109(13)	¹⁵⁹ Tb	5776.37(7)	0.120(17)	0.0023(3)
¹⁵⁹ Tb	372.980(6)	0.070(8)	0.00133(15)	¹⁵⁹ Tb	5782.28(7)	0.041(9)	0.00078(17)
¹⁵⁹ Tb	373.055(12)	0.074(13)	0.00141(25)	¹⁵⁹ Tb	5842.29(7)	0.054(10)	0.00103(19)
¹⁵⁹ Tb	374.678(6)	0.099(11)	0.00189(21)	¹⁵⁹ Tb	5860.03(23)	0.036(8)	0.00069(15)
¹⁵⁹ Tb	376.515(9)	0.039(9)	0.00074(17)	¹⁵⁹ Tb	5890.70(7)	0.137(19)	0.0026(4)
¹⁵⁹ Tb	378.740(8)	0.024(8)	0.00046(15)	¹⁵⁹ Tb	5896.46(7)	0.023(7)	0.00044(13)
¹⁵⁹ Tb	398.252(14)	0.024(5)	0.00046(10)	¹⁵⁹ Tb	5953.58(7)	0.103(13)	0.00196(25)
¹⁵⁹ Tb	399.512(9)	0.074(11)	0.00141(21)	¹⁵⁹ Tb	5993.73(7)	0.114(15)	0.0022(3)
¹⁵⁹ Tb	403.800(13)	0.028(6)	0.00053(11)	¹⁵⁹ Tb	6138.03(7)	0.110(15)	0.0021(3)
¹⁵⁹ Tb	406.214(12)	0.027(6)	0.00051(11)	¹⁵⁹Tb	6218.56(7)	0.190(22)	0.0036(4)
¹⁵⁹ Tb	413.492(9)	0.066(12)	0.00126(23)	¹⁵⁹ Tb	6235.53(7)	0.020(6)	0.00038(11)

^A Z	E _γ -keV	σ _γ ^Z (E _γ)-barns	k ₀
¹⁵⁹ Tb	6241.78(7)	0.072(10)	0.00137(19)
¹⁵⁹ Tb	6269.43(7)	0.029(6)	0.00055(11)
¹⁵⁹ Tb	6311.32(7)	0.028(6)	0.00053(11)
Dysprosium (Z=66), At.Wt.=162.50(3), σ_γ^Z=944(21)			
¹⁶⁴ Dy	50.4310(20)	33.9(15)	0.63(3)
¹⁶⁴ Dy	72.765(3)	7.1(3)	0.132(6)
¹⁶³ Dy	73.392(8)	1.70(24)	0.032(5)
¹⁶⁴ Dy	77.520(3)	2.7(5)	0.050(9)
¹⁶¹ Dy	80.64(7)	16.5(5)	0.308(9)
¹⁶⁴ Dy	83.395(3)	3.51(20)	0.065(4)
¹⁶⁴ Dy	108.159(3)d	13.6(5)	0.254[97%]
¹⁶⁴ Dy	116.768(4)	3.28(17)	0.061(3)
¹⁶⁴ Dy	139.102(4)	6.16(19)	0.115(4)
¹⁶⁴ Dy	156.245(5)	1.82(10)	0.0339(19)
¹⁶³ Dy	168.838(5)	4.7(6)	0.088(11)
¹⁶⁴ Dy	178.382(5)	1.8(3)	0.034(6)
¹⁶⁴ Dy	184.257(4)	146(15)	2.7(3)
¹⁶¹ Dy	185.19(9)	39.1(12)	0.729(22)
¹⁶³ Dy	215.082(21)	3.07(17)	0.057(3)
¹⁶² Dy	250.8900(20)	5.2(6)	0.097(11)
¹⁶¹ Dy	260.11(7)	8.3(3)	0.155(6)
¹⁶⁴ Dy	271.727(9)	2.90(17)	0.054(3)
¹⁶³ Dy	277.500(16)	1.51(16)	0.028(3)
¹⁶¹ Dy	282.89(7)	7.8(3)	0.145(6)
¹⁶³ Dy	294.575(13)	2.78(19)	0.052(4)
¹⁶¹ Dy	311.39(15)	2.1(4)	0.039(8)
¹⁶² Dy	316.3090(10)	3.0(4)	0.056(8)
¹⁶¹ Dy	321.84(12)	1.74(25)	0.032(5)
¹⁶⁴ Dy	331.126(8)	4.5(4)	0.084(8)
¹⁶¹ Dy	334.08(8)	4.9(4)	0.091(8)
¹⁶² Dy	338.5310(20)	1.50(17)	0.028(3)
¹⁶⁴ Dy	343.312(4)	3.2(4)	0.060(8)
¹⁶⁴ Dy	345.860(12)	1.8(3)	0.034(6)
¹⁶² Dy	347.9050(20)	1.84(22)	0.034(4)
¹⁶⁴ Dy	349.248(10)	14.7(6)	0.274(11)
¹⁶² Dy	351.1490(10)	10.9(9)	0.203(17)
¹⁶⁴ Dy	352.581(10)	1.7(4)	0.032(8)
¹⁶² Dy	354.2360(10)	3.5(21)	0.07(4)
¹⁶⁴ Dy	354.353(8)	3.3(10)	0.062(19)
¹⁶⁴ Dy	357.686(8)	2.4(4)	0.045(8)
¹⁶¹ Dy	361.70(10)	4.1(4)	0.076(8)
¹⁶⁴ Dy	368.727(8)	1.6(3)	0.030(6)
¹⁶⁴ Dy	380.020(8)	4.1(4)	0.076(8)
¹⁶⁴ Dy	385.9840(20)	34.8(10)	0.649(19)
¹⁶² Dy	389.7530(10)	7.7(7)	0.144(13)
¹⁶⁴ Dy	392.651(7)	11.3(5)	0.211(9)
¹⁶⁴ Dy	396.208(4)	2.4(9)	0.045(17)
¹⁶⁴ Dy	399.726(6)	2.0(4)	0.037(8)
¹⁶² Dy	401.9440(10)	1.62(19)	0.030(4)
¹⁶⁴ Dy	403.059(6)	3.5(4)	0.065(8)
¹⁶⁴ Dy	411.651(5)	35.1(10)	0.655(19)
¹⁶⁴ Dy	414.985(7)	31(5)	0.58(9)
¹⁶² Dy	415.0610(20)	1.57(19)	0.029(4)
¹⁶⁴ Dy	420.833(3)	11.8(11)	0.220(21)
¹⁶² Dy	421.8440(10)	7.1(9)	0.132(17)
¹⁶⁴ Dy	425.346(10)	2.4(7)	0.045(13)
¹⁶¹ Dy	427.57(13)	1.66(25)	0.031(5)
¹⁶² Dy	427.6800(10)	1.86(22)	0.035(4)
¹⁶⁴ Dy	430.451(8)	4.2(3)	0.078(6)
¹⁶⁴ Dy	447.893(7)	17.4(5)	0.324(9)
¹⁶⁴ Dy	465.416(6)	38.0(10)	0.709(19)
¹⁶⁴ Dy	470.227(7)	9.3(6)	0.173(11)
¹⁶⁴ Dy	474.227(7)	6.4(4)	0.119(8)
¹⁶⁴ Dy	474.95(4)	3.3(10)	0.062(19)
¹⁶² Dy	475.3880(10)	1.71(21)	0.032(4)
¹⁶⁴ Dy	477.061(6)	22(7)	0.41(13)
¹⁶⁴ Dy	477.08(4)	15.8(5)	0.295(9)
¹⁶⁴ Dy	496.931(5)	44.9(11)	0.837(21)

^A Z	E _γ -keV	σ _γ ^Z (E _γ)-barns	k ₀
¹⁶⁴ Dy	499.395(6)	13.0(10)	0.242(19)
¹⁶⁴ Dy	500.37(8)	10.3(5)	0.192(9)
¹⁶⁴ Dy	500.587(6)	10(3)	0.19(6)
¹⁶⁴ Dy	506.47(4)	6.4(4)	0.119(8)
¹⁶⁴ Dy	508.96(4)	9.5(6)	0.177(11)
¹⁶⁴ Dy	519.05(7)	1.5(3)	0.028(6)
¹⁶⁴ Dy	524.41(6)	4.7(5)	0.088(9)
¹⁶⁴ Dy	529.46(7)	3.0(10)	0.056(19)
¹⁶⁴ Dy	529.54(8)	2.5(4)	0.047(8)
¹⁶⁴ Dy	538.609(8)	69.2(19)	1.29(4)
¹⁶⁴ Dy	546.54(4)	3.7(4)	0.069(8)
¹⁶⁴ Dy	556.932(7)	2.2(4)	0.041(8)
¹⁶⁴ Dy	565.567(4)	5.1(5)	0.095(9)
¹⁶⁴ Dy	569.53(7)	8.3(25)	0.15(5)
¹⁶⁴ Dy	569.79(6)	9.7(5)	0.181(9)
¹⁶¹ Dy	572.7(4)	2.2(9)	0.041(17)
¹⁶¹ Dy	572.88(7)	1.65(12)	0.0308(22)
¹⁶⁴ Dy	583.982(5)	24(7)	0.45(13)
¹⁶⁴ Dy	596.71(4)	5.1(3)	0.095(6)
¹⁶⁴ Dy	613.13(9)	2.5(3)	0.047(6)
¹⁶¹ Dy	647.50(12)	3.11(21)	0.058(4)
¹⁶³ Dy	673.71(4)	1.7(4)	0.032(8)
¹⁶³ Dy	688.36(4)	4.7(4)	0.088(8)
¹⁶¹ Dy	697.16(9)	3.3(3)	0.062(6)
¹⁶¹ Dy	711.41(12)	2.28(22)	0.043(4)
¹⁶³ Dy	754.75(4)	6.4(4)	0.119(8)
¹⁶³ Dy	761.76(4)	4.1(3)	0.076(6)
¹⁶¹ Dy	795.27(8)	6.8(4)	0.127(8)
¹⁶¹ Dy	807.46(7)	12.1(5)	0.226(9)
¹⁶¹ Dy	842.48(22)	1.6(4)	0.030(8)
¹⁶¹ Dy	842.5(4)	1.48(25)	0.028(5)
¹⁶¹ Dy	882.27(6)	18.3(6)	0.341(11)
¹⁶¹ Dy	888.13(7)	10.4(5)	0.194(9)
¹⁶¹ Dy	917.16(10)	5.4(5)	0.101(9)
¹⁶⁴ Dy	922.11(7)	1.6(6)	0.030(11)
¹⁶¹ Dy	933.70(23)	3.1(7)	0.058(13)
¹⁶⁴ Dy	933.94(8)	4.6(7)	0.086(13)
¹⁶¹ Dy	944.40(7)	7.2(3)	0.134(6)
¹⁶¹ Dy	976.83(13)	3.4(3)	0.063(6)
¹⁶¹ Dy	979.98(9)	8.5(4)	0.159(8)
¹⁶¹ Dy	994.64(7)	9.2(4)	0.172(8)
¹⁶⁴ Dy	994.87(7)	5.6(17)	0.10(3)
¹⁶¹ Dy	1008.42(22)	2.0(3)	0.037(6)
¹⁶⁴ Dy	1018.35(8)	3.7(12)	0.069(22)
¹⁶¹ Dy	1025.5(3)	1.7(4)	0.032(8)
¹⁶¹ Dy	1058.41(9)	5.9(4)	0.110(8)
¹⁶⁴ Dy	1059.63(9)	2.2(7)	0.041(13)
¹⁶⁴ Dy	1064.18(9)	2.2(6)	0.041(11)
¹⁶⁴ Dy	1074.59(9)	4.5(14)	0.08(3)
¹⁶¹ Dy	1091.99(13)	2.7(4)	0.050(8)
¹⁶¹ Dy	1108.53(10)	5.1(4)	0.095(8)
¹⁶⁴ Dy	1110.06(9)	2.6(7)	0.048(13)
¹⁶¹ Dy	1124.81(9)	4.0(3)	0.075(6)
¹⁶¹ Dy	1129.40(9)	5.7(4)	0.106(8)
¹⁶¹ Dy	1158.2(3)	2.1(4)	0.039(8)
¹⁶¹ Dy	1185.0(3)	1.5(4)	0.028(8)
¹⁶¹ Dy	1187.7(3)	1.6(4)	0.030(8)
¹⁶¹ Dy	1195.37(12)	3.6(4)	0.067(8)
¹⁶¹ Dy	1219.6(3)	2.7(10)	0.050(19)
¹⁶⁴ Dy	1260.19(13)	2.0(6)	0.037(11)
¹⁶¹ Dy	1260.66(21)	3.2(5)	0.060(9)
¹⁶¹ Dy	1276.3(6)	1.9(4)	0.035(8)
¹⁶¹ Dy	1276.78(12)	6.3(6)	0.117(11)
¹⁶¹ Dy	1308.5(3)	1.7(4)	0.032(8)
¹⁶¹ Dy	1316.7(5)	1.5(4)	0.028(8)
¹⁶¹ Dy	1371.4(3)	2.4(4)	0.045(8)
¹⁶⁴ Dy	1410.99(8)	4.6(5)	0.086(9)
¹⁶⁴ Dy	1433.33(8)	1.9(4)	0.035(8)

^A Z	E _γ -keV	σ _γ ^Z (E _γ)-barns	k ₀
¹⁶⁴ Dy	1483.76(8)	3.6(4)	0.067(8)
¹⁶¹ Dy	1573.95(23)	1.7(3)	0.032(6)
¹⁶⁴ Dy	1596.37(15)	2.5(4)	0.047(8)
¹⁶⁴ Dy	1604.4(3)	1.7(4)	0.032(8)
¹⁶⁴ Dy	1616.1(3)	1.5(4)	0.028(8)
¹⁶⁴ Dy	1646.80(15)	2.2(3)	0.041(6)
¹⁶⁴ Dy	1671.84(13)	3.6(5)	0.067(9)
¹⁶¹ Dy	1717.18(13)	3.0(4)	0.056(8)
¹⁶⁴ Dy	1722.27(13)	3.2(4)	0.060(8)
¹⁶⁴ Dy	1737.35(15)	3.8(4)	0.071(8)
¹⁶¹ Dy	1781.5(3)	3.5(6)	0.065(11)
¹⁶⁴ Dy	1806.00(25)	2.4(5)	0.045(9)
¹⁶¹ Dy	1823.7(7)	1.9(5)	0.035(9)
¹⁶⁴ Dy	1835.40(18)	3.2(6)	0.060(11)
¹⁶⁴ Dy	1866.28(13)	2.6(4)	0.048(8)
¹⁶⁴ Dy	2019.4(3)	2.5(5)	0.047(9)
¹⁶⁴ Dy	2091.58(11)	2.6(5)	0.048(9)
¹⁶¹ Dy	2110.01(16)	3.6(4)	0.067(8)
¹⁶⁴ Dy	2113.91(11)	4.0(4)	0.075(8)
¹⁶⁴ Dy	2164.34(11)	3.1(4)	0.058(8)
¹⁶⁴ Dy	2226.92(19)	2.7(5)	0.050(9)
¹⁶⁴ Dy	2242.3(3)	3.3(5)	0.062(9)
¹⁶⁴ Dy	2259.3(3)	2.8(5)	0.052(9)
¹⁶⁴ Dy	2272.0(6)	3.6(7)	0.067(13)
¹⁶⁴ Dy	2305.5(3)	2.2(5)	0.041(9)
¹⁶⁴ Dy	2313.8(4)	7.2(6)	0.134(11)
¹⁶⁴ Dy	2369.89(24)	4.2(6)	0.078(11)
¹⁶⁴ Dy	2412.2(4)	2.6(6)	0.048(11)
¹⁶⁴ Dy	2552.64(19)	5.3(6)	0.099(11)
¹⁶⁴ Dy	2593.02(19)	3.0(5)	0.056(9)
¹⁶⁴ Dy	2606.94(19)	4.1(5)	0.076(9)
¹⁶⁴ Dy	2635.0(3)	3.0(5)	0.056(9)
¹⁶² Dy	2660.1(4)	6.6(11)	0.123(21)
¹⁶⁴ Dy	2683.54(24)	2.4(5)	0.045(9)
¹⁶⁴ Dy	2702.83(21)	6.9(22)	0.13(4)
¹⁶⁴ Dy	2823.8(4)	1.7(5)	0.032(9)
¹⁶⁴ Dy	2832.15(21)	1.9(5)	0.035(9)
¹⁶⁴ Dy	2840.1(3)	3.8(5)	0.071(9)
¹⁶⁴ Dy	2854.48(21)	4.0(5)	0.075(9)
¹⁶⁴ Dy	2863.5(4)	5.1(5)	0.095(9)
¹⁶⁴ Dy	2872.20(21)	4.5(5)	0.084(9)
¹⁶⁴ Dy	2931.8(3)	2.7(5)	0.050(9)
¹⁶⁴ Dy	2950.37(19)	4.5(5)	0.084(9)
¹⁶⁴ Dy	2999.9(4)	1.7(4)	0.032(8)
¹⁶⁴ Dy	3012.42(17)	7.8(5)	0.145(9)
¹⁶⁴ Dy	3035.55(15)	10.9(6)	0.203(11)
¹⁶⁴ Dy	3071.02(24)	3.8(5)	0.071(9)
¹⁶⁴ Dy	3098.52(24)	2.1(4)	0.039(8)
¹⁶⁴ Dy	3105.83(21)	5.8(5)	0.108(9)
¹⁶⁴ Dy	3114.06(19)	7.4(6)	0.138(11)
¹⁶⁴ Dy	3169.10(24)	3.3(4)	0.062(8)
¹⁶⁴ Dy	3198.3(3)	1.6(3)	0.030(6)
¹⁶⁴ Dy	3238.1(3)	4.7(5)	0.088(9)
¹⁶⁴ Dy	3276.05(13)	6.1(5)	0.114(9)
¹⁶⁴ Dy	3315.0(3)	3.0(4)	0.056(8)
¹⁶⁴ Dy	3443.39(11)	10.6(16)	0.20(3)
¹⁶⁴ Dy	3537.9(3)	3.2(5)	0.060(9)
¹⁶⁴ Dy	3555.71(20)	4.7(5)	0.088(9)
¹⁶⁴ Dy	3608.5(4)	3.1(4)	0.058(8)
¹⁶⁴ Dy	3628.2(3)	1.9(4)	0.035(8)
¹⁶⁴ Dy	3772.33(18)	3.1(4)	0.058(8)
¹⁶⁴ Dy	3819.95(15)	2.7(5)	0.050(9)
¹⁶⁴ Dy	3840.49(24)	4.9(6)	0.091(11)
¹⁶⁴ Dy	3885.46(13)	5.2(4)	0.097(8)
¹⁶⁴ Dy	3944.8(3)	2.2(3)	0.041(6)
¹⁶⁴ Dy	3960.93(15)	4.7(4)	0.088(8)
¹⁶⁴ Dy	4067.73(9)	2.5(4)	0.047(8)
¹⁶⁴ Dy	4083.81(14)	4.3(4)	0.080(8)

^A Z	E _γ -keV	σ _γ ^Z (E _γ)-barns	k ₀
¹⁶⁴ Dy	4123.97(8)	13.1(9)	0.244(17)
¹⁶⁴ Dy	4155.82(8)	2.1(3)	0.039(6)
¹⁶⁴ Dy	4459.45(8)	1.6(3)	0.030(6)
¹⁶⁴ Dy	4607.48(6)	1.9(4)	0.035(8)
¹⁶⁴ Dy	4612.84(7)	5.7(5)	0.106(9)
¹⁶⁴ Dy	4635.84(5)	2.6(4)	0.048(8)
¹⁶⁴ Dy	5110.77(3)	6.1(9)	0.114(17)
¹⁶⁴Dy	5142.29(3)	15.7(10)	0.293(19)
¹⁶⁴ Dy	5145.62(3)	8.4(24)	0.16(5)
¹⁶⁴ Dy	5177.25(3)	6.6(5)	0.123(9)
¹⁶¹ Dy	5450.27(25)	2.1(4)	0.039(8)
¹⁶⁴Dy	5557.26(3)	28.7(14)	0.54(3)
¹⁶⁴Dy	5607.69(3)	35.9(16)	0.67(3)
¹⁶⁰ Dy	6087.25(13)	0.85(5)	0.0159(9)
Holmium (Z=67), At. Wt.=164.93032(2), σ_γ^Z=64.7(12)			
¹⁶⁵ Ho	19.8290(20)	0.57(8)	0.0105(15)
¹⁶⁵ Ho	38.494(5)	0.179(20)	0.0033(4)
¹⁶⁵ Ho	54.2400(10)	1.41(4)	0.0259(7)
¹⁶⁵ Ho	57.521(6)	0.17(3)	0.0031(6)
¹⁶⁵ Ho	69.7610(10)	1.09(6)	0.0200(11)
¹⁶⁵ Ho	72.8870(10)	0.17(3)	0.0031(6)
¹⁶⁵ Ho	76.4670(10)	0.179(20)	0.0033(4)
¹⁶⁵ Ho	76.7270(10)	0.33(3)	0.0061(6)
¹⁶⁵Ho	80.574(8)d	3.87(5)	0.0711[1.3%]
¹⁶⁵ Ho	82.4710(20)	0.42(3)	0.0077(6)
¹⁶⁵ Ho	87.5950(20)	0.71(4)	0.0130(7)
¹⁶⁵ Ho	94.628(6)	0.156(23)	0.0029(4)
¹⁶⁵ Ho	98.8590(10)	0.270(17)	0.0050(3)
¹⁶⁵ Ho	105.516(3)	0.234(16)	0.0043(3)
¹⁶⁵ Ho	108.2000(20)	0.40(3)	0.0073(6)
¹⁶⁵ Ho	111.3260(20)	0.294(20)	0.0054(4)
¹⁶⁵Ho	116.8360(10)	8.1(4)	0.149(7)
¹⁶⁵ Ho	126.230(3)	0.55(4)	0.0101(7)
¹⁶⁵Ho	136.6650(20)	14.5(7)	0.266(13)
¹⁶⁵ Ho	140.122(5)	0.27(3)	0.0050(6)
¹⁶⁵Ho	149.309(3)	2.25(12)	0.0413(22)
¹⁶⁵ Ho	163.353(7)	0.223(15)	0.0041(3)
¹⁶⁵ Ho	167.453(5)	0.55(3)	0.0101(6)
¹⁶⁵ Ho	169.715(5)	0.150(14)	0.0028(3)
¹⁶⁵ Ho	179.036(5)	0.220(16)	0.0040(3)
¹⁶⁵ Ho	181.0870(20)	0.94(5)	0.0173(9)
¹⁶⁵ Ho	186.579(4)	0.197(22)	0.0036(4)
¹⁶⁵ Ho	197.342(3)	0.34(3)	0.0062(6)
¹⁶⁵ Ho	199.700(5)	0.48(3)	0.0088(6)
¹⁶⁵ Ho	210.309(4)	0.180(15)	0.0033(3)
¹⁶⁵Ho	221.186(4)	2.05(11)	0.0377(20)
¹⁶⁵ Ho	231.960(7)	0.23(5)	0.0042(9)
¹⁶⁵ Ho	233.116(8)	0.38(4)	0.0070(7)
¹⁶⁵Ho	239.132(4)	2.25(12)	0.0413(22)
¹⁶⁵ Ho	245.010(5)	0.47(5)	0.0086(9)
¹⁶⁵ Ho	257.806(11)	0.18(4)	0.0033(7)
¹⁶⁵ Ho	265.983(10)	0.170(14)	0.0031(3)
¹⁶⁵ Ho	267.241(6)	0.199(15)	0.0037(3)
¹⁶⁵ Ho	289.124(14)	1.16(6)	0.0213(11)
¹⁶⁵ Ho	290.617(7)	0.96(5)	0.0176(9)
¹⁶⁵ Ho	297.905(4)	0.188(14)	0.0035(3)
¹⁶⁵ Ho	304.617(6)	1.34(7)	0.0246(13)
¹⁶⁵ Ho	328.239(10)	0.391(23)	0.0072(4)
¹⁶⁵ Ho	333.614(5)	1.04(6)	0.0191(11)
¹⁶⁵ Ho	335.585(6)	0.33(7)	0.0061(13)
¹⁶⁵ Ho	343.540(6)	0.203(13)	0.00373(24)
¹⁶⁵ Ho	357.056(5)	0.162(12)	0.00298(22)
¹⁶⁵Ho	371.772(5)	1.56(8)	0.0287(15)
¹⁶⁵ Ho	391.819(7)	0.51(5)	0.0094(9)
¹⁶⁵ Ho	401.595(8)	1.07(9)	0.0197(17)
¹⁶⁵ Ho	410.265(6)	1.23(7)	0.0226(13)
¹⁶⁵ Ho	411.087(12)	0.40(12)	0.0073(22)
¹⁶⁵ Ho	412.030(8)	0.32(7)	0.0059(13)

^A Z	E _γ -keV	σ _γ ^Z (E _γ)-barns	k ₀	^A Z	E _γ -keV	σ _γ ^Z (E _γ)-barns	k ₀
¹⁶⁵ Ho	416.550(5)	0.42(4)	0.0077(7)	¹⁶⁷ Er	645.7600(20)	0.96(5)	0.0174(9)
¹⁶⁵ Ho	425.300(21)	0.69(17)	0.013(3)	¹⁶⁷ Er	673.655(3)	0.56(3)	0.0101(5)
¹⁶⁵Ho	426.012(5)	2.88(15)	0.053(3)	¹⁶⁷ Er	713.2440(10)	0.69(5)	0.0125(9)
¹⁶⁵ Ho	427.196(6)	0.21(5)	0.0039(9)	¹⁶⁷ Er	715.1610(20)	1.92(8)	0.0348(14)
¹⁶⁵ Ho	442.231(21)	0.22(3)	0.0040(6)	¹⁶⁷ Er	719.5460(20)	1.09(20)	0.020(4)
¹⁶⁵ Ho	443.148(8)	0.164(12)	0.00301(22)	¹⁶⁷ Er	720.3850(20)	1.54(16)	0.028(3)
¹⁶⁵ Ho	455.567(11)	0.78(4)	0.0143(7)	¹⁶⁷Er	730.6580(10)	11.6(4)	0.210(7)
¹⁶⁵ Ho	457.349(11)	0.213(17)	0.0039(3)	¹⁶⁷ Er	737.664(3)	1.20(6)	0.0217(11)
¹⁶⁵ Ho	463.927(6)	0.245(18)	0.0045(3)	¹⁶⁷Er	741.3650(20)	6.72(24)	0.122(4)
¹⁶⁵ Ho	467.227(5)	0.162(17)	0.0030(3)	¹⁶⁷ Er	748.280(3)	1.35(7)	0.0245(13)
¹⁶⁵ Ho	481.354(18)	0.45(7)	0.0083(13)	¹⁶⁷ Er	790.0140(20)	0.68(4)	0.0123(7)
¹⁶⁵ Ho	487.538(6)	0.394(24)	0.0072(4)	¹⁶⁷ Er	798.8940(20)	2.18(9)	0.0395(16)
¹⁶⁵ Ho	489.436(4)	1.15(6)	0.0211(11)	¹⁶⁷ Er	808.927(3)	0.81(10)	0.0147(18)
¹⁶⁵ Ho	496.932(6)	0.16(3)	0.0029(6)	¹⁶⁷ Er	811.0500(20)	1.72(22)	0.031(4)
¹⁶⁵ Ho	509.094(24)	0.332(22)	0.0061(4)	¹⁶⁷ Er	812.289(3)	1.4(3)	0.025(5)
¹⁶⁵ Ho	512.770(6)	0.323(22)	0.0059(4)	¹⁶⁷Er	815.9890(20)	42.5(15)	0.77(3)
¹⁶⁵ Ho	524.250(22)	0.260(17)	0.0048(3)	¹⁶⁷Er	821.1680(20)	6.2(3)	0.112(5)
¹⁶⁵ Ho	533.644(21)	0.303(20)	0.0056(4)	¹⁶⁷ Er	823.3810(20)	1.34(10)	0.0243(18)
¹⁶⁵ Ho	534.572(11)	0.16(3)	0.0029(6)	¹⁶⁷ Er	825.727(3)	0.89(9)	0.0161(16)
¹⁶⁵ Ho	538.259(8)	0.152(21)	0.0028(4)	¹⁶⁷ Er	829.9480(10)	4.12(19)	0.075(3)
¹⁶⁵Ho	542.780(4)	1.94(13)	0.0356(24)	¹⁶⁷Er	853.4810(10)	7.5(3)	0.136(5)
¹⁶⁵ Ho	543.676(5)	1.00(5)	0.0184(9)	¹⁶⁷ Er	862.3500(20)	1.16(6)	0.0210(11)
¹⁶⁵ Ho	554.400(11)	0.32(7)	0.0059(13)	¹⁶⁷Er	914.9420(10)	6.99(24)	0.127(4)
¹⁶⁵ Ho	576.902(16)	0.203(17)	0.0037(3)	¹⁶⁷ Er	928.9330(20)	1.55(8)	0.0281(14)
¹⁶⁵ Ho	577.141(11)	0.37(6)	0.0068(11)	¹⁶⁷ Er	932.2660(20)	0.83(5)	0.0150(9)
¹⁶⁵ Ho	613.768(6)	0.332(22)	0.0061(4)	¹⁶⁷ Er	965.9330(20)	0.83(5)	0.0150(9)
¹⁶⁵ Ho	624.234(8)	0.212(16)	0.0039(3)	¹⁶⁷ Er	999.8150(20)	0.99(6)	0.0179(11)
¹⁶⁵ Ho	633.641(8)	0.36(3)	0.0066(6)	¹⁶⁷ Er	1012.1810(20)	1.42(7)	0.0257(13)
¹⁶⁵ Ho	689.72(3)	0.44(3)	0.0081(6)	¹⁶⁷ Er	1025.368(4)	0.97(6)	0.0176(11)
¹⁶⁵ Ho	734.258(16)	0.253(18)	0.0046(3)	¹⁶⁷ Er	1144.133(3)	0.58(5)	0.0105(9)
¹⁶⁵ Ho	4855.89(3)	0.146(18)	0.0027(3)	¹⁶⁷ Er	1147.0040(20)	0.92(6)	0.0167(11)
¹⁶⁵ Ho	4945.18(5)	0.214(19)	0.0039(4)	¹⁶⁷ Er	1167.373(4)	1.98(8)	0.0359(14)
¹⁶⁵ Ho	5108.66(7)	0.33(3)	0.0061(6)	¹⁶⁷ Er	1173.577(4)	0.71(5)	0.0129(9)
¹⁶⁵ Ho	5128.946(13)	0.171(17)	0.0031(3)	¹⁶⁷ Er	1196.4640(20)	0.82(5)	0.0149(9)
¹⁶⁵ Ho	5181.841(20)	0.253(20)	0.0046(4)	¹⁶⁷ Er	1229.045(4)	0.63(5)	0.0114(9)
¹⁶⁵ Ho	5213.240(21)	0.260(24)	0.0048(4)	¹⁶⁷ Er	1274.530(6)	0.69(10)	0.0125(18)
¹⁶⁵ Ho	5428.441(9)	0.223(23)	0.0041(4)	¹⁶⁷ Er	1276.2680(20)	0.73(11)	0.0132(20)
¹⁶⁵ Ho	5524.219(11)	0.192(20)	0.0035(4)	¹⁶⁷ Er	1277.6150(20)	2.82(16)	0.051(3)
¹⁶⁵ Ho	5813.531(7)	0.54(4)	0.0099(7)	¹⁶⁷ Er	1279.088(6)	0.97(13)	0.0176(24)
¹⁶⁵ Ho	5870.477(9)	0.224(20)	0.0041(4)	¹⁶⁷ Er	1310.022(3)	1.65(8)	0.0299(14)
¹⁶⁵ Ho	5871.573(6)	0.196(18)	0.0036(3)	¹⁶⁷ Er	1323.9270(20)	1.69(8)	0.0306(14)
¹⁶⁵ Ho	6052.654(6)	0.188(19)	0.0035(4)	¹⁶⁷ Er	1331.2870(20)	1.36(7)	0.0246(13)
Erbium (Z=68), At.Wt.=167.259(3), σ_γ^Z=156.8(19)							
¹⁶² Er	69.4(6)	0.35(14)	0.0063(25)	¹⁶⁷ Er	1351.656(4)	1.94(9)	0.0351(16)
¹⁶⁷Er	79.8040(10)	18.2(8)	0.330(14)	¹⁶⁷ Er	1353.805(6)	0.56(5)	0.0101(9)
¹⁶⁷ Er	98.9850(10)	3.73(14)	0.0676(25)	¹⁶⁷ Er	1355.1(3)	0.94(12)	0.0170(22)
¹⁶⁷ Er	99.2910(10)	2.2(3)	0.040(5)	¹⁶⁷ Er	1392.181(4)	1.27(6)	0.0230(11)
¹⁶⁷Er	184.2850(10)	56(5)	1.01(9)	¹⁶⁷ Er	1515.93(4)	0.57(5)	0.0103(9)
¹⁷⁰ Er	198.0(6)	0.36(9)	0.0065(16)	¹⁶⁷ Er	1515.948(20)	0.72(12)	0.0130(22)
¹⁶⁷Er	198.2440(10)	29.9(16)	0.54(3)	¹⁶⁷ Er	1581.18(6)	0.57(6)	0.0103(11)
¹⁶⁶ Er	207.801(3)d	2.15(8)	0.0390[100%]	¹⁶⁷ Er	1649.803(7)	0.58(6)	0.0105(11)
¹⁶⁷ Er	217.4220(10)	2.66(10)	0.0482(18)	¹⁶⁷ Er	1767.00(3)	0.91(7)	0.0165(13)
¹⁶⁷ Er	255.9310(10)	0.76(3)	0.0138(5)	¹⁶⁷ Er	1834.085(7)	1.45(9)	0.0263(16)
¹⁶⁷Er	284.6560(20)	13.7(12)	0.248(22)	¹⁶⁷ Er	1835.690(4)	0.65(6)	0.0118(11)
¹⁶⁶ Er	346.553(10)	0.83(4)	0.0150(7)	¹⁶⁷ Er	1942.513(6)	0.88(7)	0.0159(13)
¹⁶⁷ Er	396.5320(10)	0.69(4)	0.0125(7)	¹⁶⁷ Er	2046.97(3)	0.56(6)	0.0101(11)
¹⁶⁷ Er	422.3180(10)	1.56(6)	0.0283(11)	¹⁶⁷ Er	2522.76(6)	0.59(9)	0.0107(16)
¹⁶⁷ Er	447.5170(20)	3.07(11)	0.0556(20)	¹⁶⁷ Er	4628.7(3)	1.02(21)	0.018(4)
¹⁶⁷ Er	457.6660(20)	0.80(4)	0.0145(7)	¹⁶⁷ Er	4643.4(3)	1.7(4)	0.031(7)
¹⁶⁷ Er	527.8840(10)	0.88(5)	0.0159(9)	¹⁶⁷ Er	4647.4(3)	0.87(18)	0.016(3)
¹⁶⁶ Er	531.46(3)	0.92(7)	0.0167(13)	¹⁶⁷ Er	4653.2(3)	1.18(24)	0.021(4)
¹⁶⁷ Er	543.6620(20)	2.01(9)	0.0364(16)	¹⁶⁷ Er	4671.4(3)	0.95(20)	0.017(4)
¹⁶⁷ Er	546.9600(20)	1.02(5)	0.0185(9)	¹⁶⁷ Er	4715.4(3)	0.98(20)	0.018(4)
¹⁶⁷ Er	559.5080(20)	2.36(10)	0.0428(18)	¹⁶⁷ Er	4745.4(3)	1.3(3)	0.024(5)
¹⁶⁷ Er	568.8260(20)	1.20(6)	0.0217(11)	¹⁶⁷ Er	4752.2(3)	0.58(12)	0.0105(22)
¹⁶⁷ Er	601.6060(20)	0.70(4)	0.0127(7)	¹⁶⁷ Er	4759.5(3)	0.74(15)	0.013(3)
¹⁶⁷Er	631.7050(20)	7.9(3)	0.143(5)	¹⁶⁷ Er	4800.76(7)	1.4(4)	0.025(7)
¹⁶⁷ Er	638.711(3)	1.04(6)	0.0188(11)	¹⁶⁸ Er	4908.73(17)	0.41(14)	0.0074(25)
				¹⁶⁷ Er	4921.42(22)	0.61(6)	0.0111(11)

^A Z	E _γ -keV	σ _γ ^Z (E _γ)-barns	k ₀
¹⁶⁷ Er	5001.79(6)	0.88(25)	0.016(5)
¹⁶⁷ Er	5031.73(19)	0.84(24)	0.015(4)
¹⁶⁷ Er	5114.2(3)	1.02(24)	0.018(4)
¹⁶⁷ Er	5169.82(18)	0.56(5)	0.0101(9)
¹⁶⁷ Er	5200.0(3)	0.67(16)	0.012(3)
¹⁶⁷ Er	5213.15(15)	1.4(3)	0.025(5)
¹⁶⁷ Er	5292.80(6)	0.63(7)	0.0114(13)
¹⁶⁷ Er	5297.19(3)	0.6(3)	0.011(5)
¹⁶⁷ Er	5359.62(5)	0.62(7)	0.0112(13)
¹⁶⁷ Er	5372.79(6)	0.9(4)	0.016(7)
¹⁶⁷ Er	5378.65(17)	0.8(4)	0.014(7)
¹⁶⁷ Er	5406.02(9)	0.8(4)	0.014(7)
¹⁶⁷ Er	5468.71(3)	0.73(15)	0.013(3)
¹⁶⁷ Er	5508.66(3)	0.66(14)	0.0120(25)
¹⁶⁷ Er	5866.25(3)	0.77(16)	0.014(3)
¹⁶⁷ Er	5878.24(3)	0.78(7)	0.0141(13)
¹⁶⁷ Er	5943.28(3)	0.95(20)	0.017(4)
¹⁶⁷ Er	5950.86(3)	0.87(18)	0.016(3)
¹⁶⁷ Er	6137.87(3)	0.57(6)	0.0103(11)
¹⁶⁷ Er	6155.99(3)	1.5(3)	0.027(5)
¹⁶⁷ Er	6201.88(3)	0.73(15)	0.013(3)
¹⁶⁶ Er	6228.54(18)	1.41(15)	0.026(3)
¹⁶⁷ Er	6229.62(3)	1.54(9)	0.0279(16)
¹⁶⁷ Er	6360.23(3)	1.3(3)	0.024(5)
¹⁶⁷ Er	6677.27(3)	1.02(6)	0.0185(11)
Thulium (Z=69), At.Wt.=168.93421(2), σ_γ^Z=105.0(20)			
¹⁶⁹ Tm	38.713	0.279(6)	0.00500(11)
¹⁶⁹ Tm	63.9550(20)	0.17(8)	0.0030(14)
¹⁶⁹ Tm	66.098	0.51(10)	0.0091(18)
¹⁶⁹ Tm	68.649	1.75(23)	0.031(4)
¹⁶⁹ Tm	69.9880(10)	0.19(7)	0.0034(13)
¹⁶⁹ Tm	75.83	0.94(8)	0.0169(14)
¹⁶⁹ Tm	87.5210(10)	1.29(3)	0.0231(5)
¹⁶⁹ Tm	87.5700(10)	0.29(6)	0.0052(11)
¹⁶⁹ Tm	89.905	0.116(21)	0.0021(4)
¹⁶⁹ Tm	105.162	0.780(23)	0.0140(4)
¹⁶⁹ Tm	107.9560(10)	0.110(13)	0.00197(23)
¹⁶⁹ Tm	111.0050(10)	0.327(16)	0.0059(3)
¹⁶⁹ Tm	114.544	3.19(6)	0.0572(11)
¹⁶⁹ Tm	130.027	0.940(25)	0.0169(5)
¹⁶⁹ Tm	144.4790(10)	1.2(4)	0.022(7)
¹⁶⁹ Tm	144.48	5.96(11)	0.1069(20)
¹⁶⁹ Tm	149.7180(10)	7.11(12)	0.1275(22)
¹⁶⁹ Tm	153.6680(10)	0.098(15)	0.0018(3)
¹⁶⁹ Tm	156.0030(10)	0.119(17)	0.0021(3)
¹⁶⁹ Tm	161.7200(10)	0.270(17)	0.0048(3)
¹⁶⁹ Tm	165.735	3.29(6)	0.0590(11)
¹⁶⁹ Tm	171.8550(10)	0.391(18)	0.0070(3)
¹⁶⁹ Tm	176.5240(10)	0.34(3)	0.0061(5)
¹⁶⁹ Tm	180.993	3.85(14)	0.0691(25)
¹⁶⁹ Tm	198.2340(10)	0.094(21)	0.0017(4)
¹⁶⁹ Tm	198.5260(10)	0.96(3)	0.0172(5)
¹⁶⁹ Tm	204.448	8.72(19)	0.156(3)
¹⁶⁹ Tm	204.7820(10)	0.25(7)	0.0045(13)
¹⁶⁹ Tm	219.706	3.64(6)	0.0653(11)
¹⁶⁹ Tm	231.8330(10)	0.60(3)	0.0108(5)
¹⁶⁹ Tm	235.1890(10)	1.18(4)	0.0212(7)
¹⁶⁹ Tm	237.2390(10)	5.52(10)	0.0990(18)
¹⁶⁹ Tm	242.6220(10)	1.28(4)	0.0230(7)
¹⁶⁹ Tm	256.4550(10)	0.096(15)	0.0017(3)
¹⁶⁹ Tm	260.3410(10)	0.103(14)	0.00185(25)
¹⁶⁹ Tm	266.8830(10)	0.134(15)	0.0024(3)
¹⁶⁹ Tm	268.5510(10)	0.210(17)	0.0038(3)
¹⁶⁹ Tm	288.1840(20)	0.172(10)	0.00309(18)
¹⁶⁹ Tm	303.6180(20)	0.137(13)	0.00246(23)
¹⁶⁹ Tm	311.0190(10)	2.50(5)	0.0448(9)
¹⁶⁹ Tm	342.7130(10)	0.14(3)	0.0025(5)
¹⁶⁹ Tm	343.5520(10)	0.360(16)	0.0065(3)

^A Z	E _γ -keV	σ _γ ^Z (E _γ)-barns	k ₀
¹⁶⁹ Tm	352.9890(20)	0.547(23)	0.0098(4)
¹⁶⁹ Tm	359.3570(20)	0.14(3)	0.0025(5)
¹⁶⁹ Tm	360.8270(20)	0.089(24)	0.0016(4)
¹⁶⁹ Tm	367.5560(20)	0.185(18)	0.0033(3)
¹⁶⁹ Tm	370.5220(20)	0.16(3)	0.0029(5)
¹⁶⁹ Tm	371.1720(20)	0.153(22)	0.0027(4)
¹⁶⁹ Tm	384.0790(20)	1.95(5)	0.0350(9)
¹⁶⁹ Tm	384.2850(20)	0.19(4)	0.0034(7)
¹⁶⁹ Tm	388.1810(20)	0.099(16)	0.0018(3)
¹⁶⁹ Tm	396.758(4)	0.099(10)	0.00178(18)
¹⁶⁹ Tm	400.1150(20)	0.717(19)	0.0129(3)
¹⁶⁹ Tm	400.6640(20)	0.20(5)	0.0036(9)
¹⁶⁹ Tm	408.3570(10)	0.239(13)	0.00429(23)
¹⁶⁹ Tm	411.5060(20)	2.37(5)	0.0425(9)
¹⁶⁹ Tm	413.1330(10)	0.162(17)	0.0029(3)
¹⁶⁹ Tm	424.6940(20)	0.556(25)	0.0100(5)
¹⁶⁹ Tm	426.783(3)	0.186(18)	0.0033(3)
¹⁶⁹ Tm	429.0390(20)	0.308(24)	0.0055(4)
¹⁶⁹ Tm	440.5100(20)	0.13(3)	0.0023(5)
¹⁶⁹ Tm	442.1490(10)	0.51(4)	0.0091(7)
¹⁶⁹ Tm	446.328(3)	1.62(4)	0.0291(7)
¹⁶⁹ Tm	454.2720(20)	0.295(20)	0.0053(4)
¹⁶⁹ Tm	456.0460(10)	1.16(4)	0.0208(7)
¹⁶⁹ Tm	457.4070(10)	0.48(12)	0.0086(22)
¹⁶⁹ Tm	457.4100(20)	0.557(25)	0.0100(5)
¹⁶⁹ Tm	468.4740(20)	0.45(4)	0.0081(7)
¹⁶⁹ Tm	468.7760(20)	0.41(8)	0.0074(14)
¹⁶⁹ Tm	472.6610(10)	0.60(5)	0.0108(9)
¹⁶⁹ Tm	473.5790(10)	0.15(4)	0.0027(7)
¹⁶⁹ Tm	477.027(4)	0.240(25)	0.0043(5)
¹⁶⁹ Tm	481.3490(20)	0.109(22)	0.0020(4)
¹⁶⁹ Tm	485.210(4)	0.140(22)	0.0025(4)
¹⁶⁹ Tm	496.5720(20)	0.80(3)	0.0144(5)
¹⁶⁹ Tm	499.0260(20)	0.40(8)	0.0072(14)
¹⁶⁹ Tm	499.5560(20)	0.88(3)	0.0158(5)
¹⁶⁹ Tm	505.018(7)	0.90(3)	0.0161(5)
¹⁶⁹ Tm	505.341(9)	0.84(3)	0.0151(5)
¹⁶⁹ Tm	512.1370(20)	1.96(5)	0.0352(9)
¹⁶⁹ Tm	512.6080(20)	0.108(22)	0.0019(4)
¹⁶⁹ Tm	517.053(4)	0.15(3)	0.0027(5)
¹⁶⁹ Tm	523.3590(20)	0.48(3)	0.0086(5)
¹⁶⁹ Tm	532.4280(20)	0.59(3)	0.0106(5)
¹⁶⁹ Tm	532.858(3)	0.12(3)	0.0022(5)
¹⁶⁹ Tm	535.8280(10)	1.18(4)	0.0212(7)
¹⁶⁹ Tm	537.9910(20)	1.00(4)	0.0179(7)
¹⁶⁹ Tm	551.5140(20)	1.29(25)	0.023(5)
¹⁶⁹ Tm	562.4440(20)	0.85(3)	0.0152(5)
¹⁶⁹ Tm	565.2770(20)	1.58(4)	0.0283(7)
¹⁶⁹ Tm	569.1730(20)	1.02(3)	0.0183(5)
¹⁶⁹ Tm	569.5440(20)	0.44(9)	0.0079(16)
¹⁶⁹ Tm	573.017(4)	0.39(7)	0.0070(13)
¹⁶⁹ Tm	573.017(4)	0.30(9)	0.0054(16)
¹⁶⁹ Tm	581.2690(20)	0.32(7)	0.0057(13)
¹⁶⁹ Tm	585.1540(10)	0.60(4)	0.0108(7)
¹⁶⁹ Tm	589.0850(10)	0.58(10)	0.0104(18)
¹⁶⁹ Tm	590.2270(20)	1.27(10)	0.0228(18)
¹⁶⁹ Tm	599.1890(20)	0.155(25)	0.0028(5)
¹⁶⁹ Tm	601.9780(20)	0.13(3)	0.0023(5)
¹⁶⁹ Tm	603.9900(20)	1.40(5)	0.0251(9)
¹⁶⁹ Tm	610.0310(20)	0.18(4)	0.0032(7)
¹⁶⁹ Tm	611.6590(10)	0.83(4)	0.0149(7)
¹⁶⁹ Tm	619.423(3)	0.23(4)	0.0041(7)
¹⁶⁹ Tm	621.812(3)	0.12(3)	0.0022(5)
¹⁶⁹ Tm	623.1420(10)	0.27(4)	0.0048(7)
¹⁶⁹ Tm	632.4310(20)	0.74(3)	0.0133(5)
¹⁶⁹ Tm	637.900(3)	1.25(4)	0.0224(7)
¹⁶⁹ Tm	637.9020(20)	1.8(3)	0.032(5)
¹⁶⁹ Tm	640.7790(20)	0.70(3)	0.0126(5)

^A Z	E _γ -keV	σ _γ ^z (E _γ)-barns	k ₀	^A Z	E _γ -keV	σ _γ ^z (E _γ)-barns	k ₀
¹⁶⁹ Tm	648.7440(20)	0.24(4)	0.0043(7)	¹⁶⁹ Tm	4732.6(4)	0.58(5)	0.0104(9)
¹⁶⁹Tm	650.3720(10)	1.45(5)	0.0260(9)	¹⁶⁹ Tm	4773.8(8)	0.16(3)	0.0029(5)
¹⁶⁹Tm	658.913(5)	1.56(5)	0.0280(9)	¹⁶⁹ Tm	4922.1(5)	0.26(3)	0.0047(5)
¹⁶⁹ Tm	664.9160(10)	0.30(4)	0.0054(7)	¹⁶⁹ Tm	4987.0(6)	0.16(3)	0.0029(5)
¹⁶⁹ Tm	669.656(4)	0.31(4)	0.0056(7)	¹⁶⁹ Tm	5061.6(8)	0.103(21)	0.0018(4)
¹⁶⁹ Tm	670.753(7)	0.12(4)	0.0022(7)	¹⁶⁹ Tm	5075.3(5)	0.39(4)	0.0070(7)
¹⁶⁹ Tm	679.5820(20)	0.15(3)	0.0027(5)	¹⁶⁹ Tm	5124.1(5)	0.28(4)	0.0050(7)
¹⁶⁹ Tm	680.5480(20)	0.41(3)	0.0074(5)	¹⁶⁹ Tm	5149.1(6)	0.31(4)	0.0056(7)
¹⁶⁹ Tm	693.2840(10)	0.30(3)	0.0054(5)	¹⁶⁹ Tm	5158.2(6)	0.47(5)	0.0084(9)
¹⁶⁹ Tm	694.085(13)	~0.1	~0.002	¹⁶⁹ Tm	5216.5(9)	0.092(25)	0.0017(5)
¹⁶⁹Tm	703.6280(10)	1.32(4)	0.0237(7)	¹⁶⁹ Tm	5326.80(11)	0.18(3)	0.0032(5)
¹⁶⁹ Tm	707.8490(10)	0.50(10)	0.0090(18)	¹⁶⁹ Tm	5353.72(11)	0.19(3)	0.0034(5)
¹⁶⁹ Tm	709.381(3)	0.107(21)	0.0019(4)	¹⁶⁹ Tm	5381.18(11)	0.18(3)	0.0032(5)
¹⁶⁹ Tm	710.7670(20)	0.60(3)	0.0108(5)	¹⁶⁹ Tm	5399.03(11)	0.143(25)	0.0026(5)
¹⁶⁹ Tm	711.1330(20)	0.33(7)	0.0059(13)	¹⁶⁹ Tm	5412.95(11)	0.39(5)	0.0070(9)
¹⁶⁹ Tm	714.433(5)	0.089(20)	0.0016(4)	¹⁶⁹ Tm	5423.08(11)	0.24(3)	0.0043(5)
¹⁶⁹Tm	719.2610(20)	1.01(3)	0.0181(5)	¹⁶⁹ Tm	5431.26(11)	0.23(3)	0.0041(5)
¹⁶⁹ Tm	720.8210(20)	0.57(3)	0.0102(5)	¹⁶⁹ Tm	5443.88(11)	0.150(25)	0.0027(5)
¹⁶⁹ Tm	724.585(3)	0.68(3)	0.0122(5)	¹⁶⁹ Tm	5451.91(11)	0.148(25)	0.0027(5)
¹⁶⁹ Tm	739.794(4)	0.108(18)	0.0019(3)	¹⁶⁹ Tm	5513.01(11)	0.16(5)	0.0029(9)
¹⁶⁹ Tm	744.765(7)	0.124(19)	0.0022(3)	¹⁶⁹ Tm	5683.40(11)	0.104(21)	0.0019(4)
¹⁶⁹ Tm	748.2310(20)	0.102(20)	0.0018(4)	¹⁶⁹ Tm	5728.48(11)	0.26(3)	0.0047(5)
¹⁶⁹ Tm	781.278(7)	0.20(4)	0.0036(7)	¹⁶⁹Tm	5731.36(11)	1.17(22)	0.021(4)
¹⁶⁹ Tm	781.279(7)	0.19(4)	0.0034(7)	¹⁶⁹Tm	5737.51(11)	1.42(7)	0.0255(13)
¹⁶⁹ Tm	781.832(4)	0.090(20)	0.0016(4)	¹⁶⁹ Tm	5809.69(11)	0.147(20)	0.0026(4)
¹⁶⁹ Tm	784.900(4)	0.18(4)	0.0032(7)	¹⁶⁹ Tm	5858.03(11)	0.41(4)	0.0074(7)
¹⁶⁹ Tm	790.216(4)	0.17(3)	0.0030(5)	¹⁶⁹ Tm	5898.56(11)	0.35(4)	0.0063(7)
¹⁶⁹ Tm	800.424(6)	0.122(23)	0.0022(4)	¹⁶⁹ Tm	5908.27(11)	0.49(4)	0.0088(7)
¹⁶⁹ Tm	810.7260(20)	0.157(21)	0.0028(4)	¹⁶⁹Tm	5941.47(11)	1.51(7)	0.0271(13)
¹⁶⁹ Tm	815.624(4)	0.76(3)	0.0136(5)	¹⁶⁹Tm	5943.09(11)	1.03(20)	0.018(4)
¹⁶⁹ Tm	818.5070(20)	0.233(20)	0.0042(4)	¹⁶⁹Tm	6001.61(11)	0.99(10)	0.0178(18)
¹⁶⁹ Tm	824.0610(20)	0.318(22)	0.0057(4)	¹⁶⁹ Tm	6354.59(11)	0.42(4)	0.0075(7)
¹⁶⁹ Tm	844.677(9)	0.147(18)	0.0026(3)	¹⁶⁹Tm	6387.37(11)	1.48(7)	0.0265(13)
¹⁶⁹Tm	854.337(4)	1.41(4)	0.0253(7)	¹⁶⁹ Tm	6442.10(11)	0.47(3)	0.0084(5)
¹⁶⁹ Tm	866.522(6)	0.353(24)	0.0063(4)	¹⁶⁹ Tm	6553.10(11)	0.65(13)	0.0117(23)
¹⁶⁹ Tm	869.401(4)	0.235(23)	0.0042(4)	Ytterbium (Z=70), At. Wt.=173.04(3), σ_γ^z=34.9(8)			
¹⁶⁹ Tm	886.5560(20)	0.230(24)	0.0041(4)	¹⁷⁰ Yb	19.3940(20)	0.021(5)	0.00037(9)
¹⁶⁹ Tm	890.047(3)	0.17(4)	0.0030(7)	¹⁷⁴Yb	41.2180(20)	1.1(3)	0.019(5)
¹⁶⁹ Tm	920.507(9)	0.113(24)	0.0020(4)	¹⁷⁴Yb	46.7510(20)	0.25(8)	0.0044(14)
¹⁶⁹ Tm	928.265(4)	0.37(3)	0.0066(5)	¹⁶⁸ Yb	62.7190(10)	0.064(12)	0.00112(21)
¹⁶⁹ Tm	943.522(4)	0.24(3)	0.0043(5)	¹⁷⁰ Yb	66.720(10)	0.024(6)	0.00042(11)
¹⁶⁹ Tm	956.145(3)	0.33(6)	0.0059(11)	¹⁶⁸ Yb	75.0400(10)	0.015(3)	0.00026(5)
¹⁶⁹ Tm	959.201(4)	0.28(3)	0.0050(5)	¹⁷³Yb	76.996	0.40(4)	0.0070(7)
¹⁶⁹ Tm	959.220(9)	0.45(9)	0.0081(16)	¹⁷¹Yb	78.7430(10)	0.67(10)	0.0117(18)
¹⁶⁹ Tm	973.121(12)	0.10(4)	0.0018(7)	¹⁷³Yb	86.11(7)	0.164(18)	0.0029(3)
¹⁶⁹ Tm	987.453(3)	0.30(3)	0.0054(5)	¹⁶⁸ Yb	87.3840(10)	0.016(3)	0.00028(5)
¹⁶⁹ Tm	995.714(4)	0.106(23)	0.0019(4)	¹⁷⁴Yb	87.9690(20)	0.26(6)	0.0046(11)
¹⁶⁹ Tm	998.253(4)	0.200(25)	0.0036(5)	¹⁷³ Yb	88.26(11)	0.044(8)	0.00077(14)
¹⁶⁹ Tm	1000.898(10)	0.23(4)	0.0041(7)	¹⁷⁴ Yb	89.9570(20)	0.066(16)	0.0012(3)
¹⁶⁹ Tm	1018.431(10)	0.28(6)	0.0050(11)	¹⁷³ Yb	93.60(6)	0.109(13)	0.00191(23)
¹⁶⁹ Tm	1027.820(12)	0.26(4)	0.0047(7)	¹⁷⁴Yb	95.2730(20)	0.20(5)	0.0035(9)
¹⁶⁹ Tm	1040.1330(10)	0.25(7)	0.0045(13)	¹⁷⁴ Yb	100.759(4)	0.019(7)	0.00033(12)
¹⁶⁹ Tm	1043.108(12)	0.19(4)	0.0034(7)	¹⁷³Yb	102.60(5)	0.44(5)	0.0077(9)
¹⁶⁹ Tm	1045.353(12)	0.18(4)	0.0032(7)	¹⁷⁴Yb	104.5260(20)	0.43(11)	0.0075(19)
¹⁶⁹ Tm	1061.868(14)	0.49(10)	0.0088(18)	¹⁷⁴Yb	113.805(4)d	0.417(14)	0.00730[<0.1%]
¹⁶⁹ Tm	1070.969(6)	0.30(6)	0.0054(11)	¹⁷⁶ Yb	125.23(18)	0.007(3)	1.2(5)E-4
¹⁶⁹ Tm	1101.996(3)	0.10(3)	0.0018(5)	¹⁷³ Yb	138.27(6)	0.058(7)	0.00102(12)
¹⁶⁹ Tm	1140.192(4)	0.62(12)	0.0111(22)	¹⁷⁴ Yb	142.0240(20)	0.032(8)	0.00056(14)
¹⁶⁹ Tm	1154.112(12)	0.18(4)	0.0032(7)	¹⁷⁴ Yb	142.478(3)	0.021(5)	0.00037(9)
¹⁶⁹ Tm	1171.966(11)	0.14(3)	0.0025(5)	¹⁶⁸ Yb	144.5760(10)	0.016(3)	0.00028(5)
¹⁶⁹ Tm	1178.905(4)	0.56(4)	0.0100(7)	¹⁷³ Yb	148.72(9)	0.031(5)	0.00054(9)
¹⁶⁹ Tm	1184.563(14)	0.20(3)	0.0036(5)	¹⁶⁸ Yb	156.8980(10)	0.038(7)	0.00067(12)
¹⁶⁹ Tm	1210.678(11)	0.36(7)	0.0065(13)	¹⁷⁴ Yb	163.012(5)	0.132(25)	0.0023(4)
¹⁶⁹ Tm	1226.345(12)	0.120(22)	0.0022(4)	¹⁷⁴ Yb	172.167(4)	0.118(22)	0.0021(4)
¹⁶⁹ Tm	1238.136(10)	0.107(21)	0.0019(4)	¹⁷³Yb	175.30(5)	0.58(6)	0.0102(11)
¹⁶⁹ Tm	1265.057(12)	0.210(24)	0.0038(4)	¹⁷¹Yb	181.529(3)	0.53(6)	0.0093(11)
¹⁶⁹ Tm	1354.71(7)	0.128(23)	0.0023(4)	¹⁶⁸Yb	191.2140(10)	0.22(4)	0.0039(7)
¹⁶⁹ Tm	4641.4(4)	0.32(3)	0.0057(5)	¹⁷³ Yb	198.29(12)	0.023(4)	0.00040(7)

^A Z	E _γ -keV	σ _γ ^Z (E _γ)-barns	k ₀	^A Z	E _γ -keV	σ _γ ^Z (E _γ)-barns	k ₀
¹⁷³ Yb	223.00(8)	0.029(4)	0.00051(7)	¹⁷⁴ Yb	639.261(9)	1.43(17)	0.025(3)
¹⁷⁴ Yb	231.502(6)	0.060(8)	0.00105(14)	¹⁷⁴ Yb	657.441(11)	0.031(8)	0.00054(14)
¹⁷⁴ Yb	232.435(3)	0.025(4)	0.00044(7)	¹⁶⁸ Yb	660.180(11)	0.016(3)	0.00028(5)
¹⁷³ Yb	243.68(19)	0.018(4)	0.00032(7)	¹⁷³ Yb	661.5(3)	0.024(6)	0.00042(11)
¹⁷⁴ Yb	246.778(14)	0.024(7)	0.00042(12)	¹⁷⁰ Yb	669.95(7)	0.120(15)	0.0021(3)
¹⁷⁴ Yb	255.338(5)	0.033(10)	0.00058(18)	¹⁷⁴ Yb	680.17(4)	0.034(6)	0.00060(11)
¹⁷⁴ Yb	267.538(5)	0.073(10)	0.00128(18)	¹⁷⁴ Yb	680.67(14)	0.031(7)	0.00054(12)
¹⁷³ Yb	274.90(7)	0.044(6)	0.00077(11)	¹⁷³ Yb	684.74(10)	0.052(8)	0.00091(14)
¹⁷⁴ Yb	282.522(14)d	0.666(22)	0.0117[<0.1%]	¹⁷³ Yb	689.8(4)	0.015(5)	0.00026(9)
¹⁷¹ Yb	287.138(3)	0.062(11)	0.00109(19)	¹⁶⁸ Yb	690.968(10)	0.037(6)	0.00065(11)
¹⁷⁴ Yb	288.626(17)	0.016(3)	0.00028(5)	¹⁷⁰ Yb	691.62(13)	0.045(8)	0.00079(14)
¹⁷⁴ Yb	311.276(5)	0.26(4)	0.0046(7)	¹⁷⁴ Yb	697.29(4)	0.034(8)	0.00060(14)
¹⁷³ Yb	341.27(16)	0.026(5)	0.00046(9)	¹⁷⁰ Yb	698.36(11)	0.052(7)	0.00091(12)
¹⁷⁴ Yb	363.938(6)	0.80(12)	0.0140(21)	¹⁷⁴ Yb	707.45(4)	0.121(19)	0.0021(3)
¹⁶⁸ Yb	378.616(3)	0.033(6)	0.00058(11)	¹⁶⁸ Yb	719.969(22)	0.141(15)	0.0025(3)
¹⁷⁴ Yb	389.422(5)	0.032(5)	0.00056(9)	¹⁷⁴ Yb	725.975(21)	0.015(5)	0.00026(9)
¹⁷⁴ Yb	392.114(11)	0.097(12)	0.00170(21)	¹⁶⁸ Yb	726.422(11)	0.049(6)	0.00086(11)
¹⁷⁴ Yb	396.329(20)d	1.42(5)	0.0249[<0.1%]	¹⁷⁴ Yb	729.218(9)	0.128(16)	0.0022(3)
¹⁷² Yb	399.17(4)	0.111(12)	0.00194(21)	¹⁷⁴ Yb	740.17(5)	0.038(11)	0.00067(19)
¹⁷⁴ Yb	400.996(15)	0.015(4)	0.00026(7)	¹⁷⁴ Yb	742.0(4)	0.076(12)	0.00133(21)
¹⁷⁴ Yb	405.156(6)	0.040(6)	0.00070(11)	¹⁶⁸ Yb	761.850(10)	0.039(7)	0.00068(12)
¹⁷⁴ Yb	406.05(14)	0.111(14)	0.00194(25)	¹⁷³ Yb	762.65(8)	0.069(9)	0.00121(16)
¹⁷⁴ Yb	406.548(5)	0.118(18)	0.0021(3)	¹⁷⁴ Yb	767.169(9)	0.151(25)	0.0026(4)
¹⁷³ Yb	409.38(7)	0.031(5)	0.00054(9)	¹⁷⁰ Yb	774.42(9)	0.042(6)	0.00074(11)
¹⁷³ Yb	411.48(11)	0.021(4)	0.00037(7)	¹⁷⁴ Yb	800.409(16)	0.111(16)	0.0019(3)
¹⁷⁴ Yb	423.219(11)	0.045(7)	0.00079(12)	¹⁷⁴ Yb	811.427(9)	0.92(16)	0.016(3)
¹⁷⁴ Yb	428.613(12)	0.61(7)	0.0107(12)	¹⁷⁴ Yb	812.019(11)	0.10(3)	0.0018(5)
¹⁷⁴ Yb	436.173(5)	0.52(6)	0.0091(11)	¹⁷⁴ Yb	816.14(4)	0.132(21)	0.0023(4)
¹⁷⁴ Yb	436.472(16)	0.037(8)	0.00065(14)	¹⁷⁴ Yb	825.22(7)	0.154(24)	0.0027(4)
¹⁷⁴ Yb	452.80(14)	0.019(3)	0.00033(5)	¹⁶⁸ Yb	827.193(11)	0.023(4)	0.00040(7)
¹⁷⁴ Yb	453.299(6)	0.031(6)	0.00054(11)	¹⁷⁴ Yb	841.627(16)	0.138(17)	0.0024(3)
¹⁷⁴ Yb	465.033(11)	0.06(4)	0.0011(7)	¹⁷⁴ Yb	852.951(20)	0.049(13)	0.00086(23)
¹⁷⁴ Yb	468.079(19)	0.022(4)	0.00039(7)	¹⁷¹ Yb	854.504(22)	0.020(4)	0.00035(7)
¹⁷⁴ Yb	476.606(11)	0.015(4)	0.00026(7)	¹⁷¹ Yb	857.621(7)	0.208(25)	0.0036(4)
¹⁷⁴ Yb	476.643(8)	0.015(4)	0.00026(7)	¹⁷⁴ Yb	858.05(5)	0.045(10)	0.00079(18)
¹⁷⁴ Yb	477.391(5)	0.75(8)	0.0131(14)	¹⁷⁴ Yb	866.027(11)	0.017(7)	0.00030(12)
¹⁷⁴ Yb	482.071(11)	0.23(3)	0.0040(5)	¹⁷⁴ Yb	869.60(4)	0.100(18)	0.0018(3)
¹⁷¹ Yb	490.444(8)	0.0172(24)	0.00030(4)	¹⁷⁰ Yb	869.7(15)	0.026(6)	0.00046(11)
¹⁷⁴ Yb	496.414(11)	0.023(7)	0.00040(12)	¹⁷⁴ Yb	871.695(9)	0.24(4)	0.0042(7)
¹⁷⁴ Yb	497.717(10)	0.022(5)	0.00039(9)	¹⁷⁴ Yb	894.47(5)	0.066(13)	0.00116(23)
¹⁷⁴ Yb	498.315(9)	0.076(11)	0.00133(19)	¹⁷⁴ Yb	905.0(4)	0.045(12)	0.00079(21)
¹⁷⁴ Yb	505.05(5)	0.030(8)	0.00053(14)	¹⁷⁰ Yb	906.15(14)	0.040(7)	0.00070(12)
¹⁷⁴ Yb	511.784(11)	0.34(5)	0.0060(9)	¹⁷¹ Yb	912.145(9)	0.049(8)	0.00086(14)
¹⁷⁴ Yb	514.868(7)d	9.0(9)	0.158[100%]	¹⁷⁰ Yb	923.4(3)	0.019(6)	0.00033(11)
¹⁷⁴ Yb	518.491(11)	0.037(9)	0.00065(16)	¹⁷⁴ Yb	941.22(5)	0.082(15)	0.0014(3)
¹⁷¹ Yb	528.289(7)	0.024(3)	0.00042(5)	¹⁷⁴ Yb	945.21(4)	0.069(15)	0.0012(3)
¹⁷⁴ Yb	534.735(9)	0.50(6)	0.0088(11)	¹⁷⁴ Yb	947.01(23)	0.076(12)	0.00133(21)
¹⁷⁴ Yb	548.841(12)	0.020(7)	0.00035(12)	¹⁷⁴ Yb	953.996(11)	0.095(24)	0.0017(4)
¹⁷⁴ Yb	553.002(11)	0.091(13)	0.00159(23)	¹⁷⁴ Yb	957.477(20)	0.017(7)	0.00030(12)
¹⁷⁴ Yb	556.090(8)	0.066(11)	0.00116(19)	¹⁷⁴ Yb	960.34(4)	0.015(7)	0.00026(12)
¹⁷¹ Yb	558.935(8)	0.020(3)	0.00035(5)	¹⁷¹ Yb	961.489(8)	0.120(17)	0.0021(3)
¹⁷⁴ Yb	565.242(11)	0.039(8)	0.00068(14)	¹⁷⁰ Yb	963.15(9)	0.117(14)	0.00205(25)
¹⁷³ Yb	570.30(19)	0.028(6)	0.00049(11)	¹⁷¹ Yb	964.197(10)	0.229(25)	0.0040(4)
¹⁷⁴ Yb	571.915(8)	0.047(7)	0.00082(12)	¹⁷⁴ Yb	982.44(5)	0.129(23)	0.0023(4)
¹⁶⁸ Yb	572.700(7)	0.049(8)	0.00086(14)	¹⁷⁴ Yb	988.22(4)	0.088(19)	0.0015(3)
¹⁶⁸ Yb	576.398(10)	0.024(4)	0.00042(7)	¹⁷⁰ Yb	990.18(15)	0.051(11)	0.00089(19)
¹⁷¹ Yb	576.4(3)	0.020(3)	0.00035(5)	¹⁷¹ Yb	995.79(4)	0.020(3)	0.00035(5)
¹⁷⁴ Yb	577.28(5)	0.046(8)	0.00081(14)	¹⁷⁴ Yb	1005.49(23)	0.033(10)	0.00058(18)
¹⁶⁸ Yb	590.695(10)	0.090(15)	0.0016(3)	¹⁷⁴ Yb	1006.00(25)	0.054(17)	0.0009(3)
¹⁷¹ Yb	602.469(5)	0.030(4)	0.00053(7)	¹⁷⁴ Yb	1009.5(4)	0.082(17)	0.0014(3)
¹⁷⁴ Yb	602.841(8)	0.072(10)	0.00126(18)	¹⁷¹ Yb	1021.4(3)	0.0182(25)	0.00032(4)
¹⁷⁴ Yb	618.09(4)	0.020(4)	0.00035(7)	¹⁷⁴ Yb	1022.62(23)	0.035(13)	0.00061(23)
¹⁶⁸ Yb	622.127(11)	0.034(6)	0.00060(11)	¹⁷¹ Yb	1026.315(17)	0.0151(19)	0.00026(3)
¹⁶⁸ Yb	623.026(7)	0.035(6)	0.00061(11)	¹⁷¹ Yb	1039.150(7)	0.22(3)	0.0039(5)
¹⁷⁴ Yb	624.692(9)	0.026(4)	0.00046(7)	¹⁷³ Yb	1055.83(18)	0.037(7)	0.00065(12)
¹⁷⁴ Yb	635.22(4)	0.078(13)	0.00137(23)	¹⁷¹ Yb	1070.475(15)	0.025(3)	0.00044(5)
¹⁶⁸ Yb	635.348(7)	0.103(17)	0.0018(3)	¹⁷¹ Yb	1076.246(6)	0.52(6)	0.0091(11)
¹⁶⁸ Yb	635.418(7)	0.103(17)	0.0018(3)	¹⁷¹ Yb	1093.674(9)	0.24(3)	0.0042(5)

^A Z	E _γ -keV	σ _γ ^Z (E _γ)-barns	k ₀	^A Z	E _γ -keV	σ _γ ^Z (E _γ)-barns	k ₀
¹⁷⁰ Yb	1099.82(19)	0.040(7)	0.00070(12)	¹⁷¹ Yb	1956.39(3)	0.028(4)	0.00049(7)
¹⁷⁴ Yb	1115.5(3)	0.11(3)	0.0019(5)	¹⁷¹ Yb	1968.29(3)	0.061(14)	0.00107(25)
¹⁷¹ Yb	1117.892(7)	0.086(14)	0.00151(25)	¹⁷¹ Yb	1997.515(21)	0.044(7)	0.00077(12)
¹⁷¹ Yb	1119.780(8)	0.46(6)	0.0081(11)	¹⁷³ Yb	2003.14(25)	0.045(10)	0.00079(18)
¹⁷⁴ Yb	1122.3(10)	0.09(3)	0.0016(5)	¹⁷¹ Yb	2009.50(5)	0.074(12)	0.00130(21)
¹⁷³ Yb	1129.81(17)	0.128(17)	0.0022(3)	¹⁷¹ Yb	2024.16(3)	0.081(12)	0.00142(21)
¹⁷⁰ Yb	1138.9(3)	0.042(13)	0.00074(23)	¹⁷³ Yb	2093.9(3)	0.026(8)	0.00046(14)
¹⁷¹ Yb	1143.017(8)	0.106(13)	0.00186(23)	¹⁷¹ Yb	2102.90(3)	0.040(5)	0.00070(9)
¹⁷¹ Yb	1152.16(5)	0.021(3)	0.00037(5)	¹⁷¹ Yb	2115.56(4)	0.039(7)	0.00068(12)
¹⁷¹ Yb	1154.989(6)	0.099(13)	0.00173(23)	¹⁷¹ Yb	2133.85(7)	0.043(6)	0.00075(11)
¹⁷⁴ Yb	1187.7(3)	0.054(17)	0.0009(3)	¹⁷³ Yb	2171.4(3)	0.059(12)	0.00103(21)
¹⁶⁸ Yb	1207.44(7)	0.018(4)	0.00032(7)	¹⁷¹ Yb	2195.09(5)	0.066(11)	0.00116(19)
¹⁶⁸ Yb	1221.20(3)	0.015(3)	0.00026(5)	¹⁷¹ Yb	2234.17(10)	0.042(11)	0.00074(19)
¹⁶⁸ Yb	1232.902(13)	0.018(3)	0.00032(5)	¹⁷¹ Yb	2238.19(3)	0.052(12)	0.00091(21)
¹⁶⁸ Yb	1263.261(19)	0.024(5)	0.00042(9)	¹⁷¹ Yb	2263.11(3)	0.042(11)	0.00074(19)
¹⁷⁰ Yb	1265.10(22)	0.081(12)	0.00142(21)	¹⁷¹ Yb	2296.47(4)	0.035(7)	0.00061(12)
¹⁷¹ Yb	1288.873(12)	0.019(3)	0.00033(5)	¹⁷¹ Yb	2327.57(8)	0.094(19)	0.0016(3)
¹⁷³ Yb	1292.2(4)	0.036(9)	0.00063(16)	¹⁷³ Yb	2388.7(4)	0.036(10)	0.00063(18)
¹⁶⁸ Yb	1295.620(13)	0.017(3)	0.00030(5)	¹⁷¹ Yb	2401.37(3)	0.20(3)	0.0035(5)
¹⁷⁴ Yb	1296.3(3)	0.046(17)	0.0008(3)	¹⁷⁴ Yb	3632.3(10)	0.40(10)	0.0070(18)
¹⁷³ Yb	1308.53(11)	0.168(19)	0.0029(3)	¹⁷⁴ Yb	3661.2(14)	0.043(10)	0.00075(18)
¹⁷¹ Yb	1326.286(7)	0.055(7)	0.00096(12)	¹⁷⁴ Yb	3714.7(5)	0.23(6)	0.0040(11)
¹⁷³ Yb	1353.21(22)	0.041(9)	0.00072(16)	¹⁷⁴ Yb	3740.8(14)	0.043(10)	0.00075(18)
¹⁷⁰ Yb	1371.3(4)	0.023(8)	0.00040(14)	¹⁷⁴ Yb	3776.2(23)	0.040(10)	0.00070(18)
¹⁶⁸ Yb	1374.45(7)	0.021(4)	0.00037(7)	¹⁷⁴ Yb	3782.9(19)	0.057(14)	0.00100(25)
¹⁷⁴ Yb	1378.22(7)	0.42(12)	0.0074(21)	¹⁷⁴ Yb	3823.8(14)	0.026(6)	0.00046(11)
¹⁷⁴ Yb	1378.7(10)	0.046(17)	0.0008(3)	¹⁷⁴ Yb	3842.1(14)	0.074(18)	0.0013(3)
¹⁷³ Yb	1381.48(14)	0.129(16)	0.0023(3)	¹⁷⁴ Yb	3854.4(11)	0.085(16)	0.0015(3)
¹⁷¹ Yb	1387.243(7)	0.142(18)	0.0025(3)	¹⁷³ Yb	3868.0(4)	0.103(14)	0.00180(25)
¹⁷¹ Yb	1398.07(4)	0.134(16)	0.0023(3)	¹⁷⁴ Yb	3885.0(4)	0.72(17)	0.013(3)
¹⁶⁸ Yb	1410.40(14)	0.015(8)	0.00026(14)	¹⁷⁴ Yb	3929.3(4)	0.38(9)	0.0067(16)
¹⁶⁸ Yb	1432.33(7)	0.016(4)	0.00028(7)	¹⁷⁴ Yb	3978.2(19)	0.020(5)	0.00035(9)
¹⁷¹ Yb	1450.264(20)	0.032(5)	0.00056(9)	¹⁷⁴ Yb	4129.6(19)	0.026(6)	0.00046(11)
¹⁷³ Yb	1456.65(23)	0.083(15)	0.0015(3)	¹⁷⁴ Yb	4138.6(19)	0.023(6)	0.00040(11)
¹⁷¹ Yb	1465.985(7)	0.095(11)	0.00166(19)	¹⁷⁴ Yb	4174.9(13)	0.088(21)	0.0015(4)
¹⁷⁰ Yb	1469.79(17)	0.096(16)	0.0017(3)	¹⁷⁴ Yb	4195.0(4)	0.058(14)	0.00102(25)
¹⁷¹ Yb	1470.401(12)	0.058(7)	0.00102(12)	¹⁷⁴ Yb	4454.3(4)	0.026(6)	0.00046(11)
¹⁷¹ Yb	1476.81(4)	0.048(6)	0.00084(11)	¹⁷⁴ Yb	4465.9(4)	0.040(10)	0.00070(18)
¹⁷³ Yb	1480.63(24)	0.050(12)	0.00088(21)	¹⁷³ Yb	4716.5(7)	0.027(8)	0.00047(14)
¹⁷⁰ Yb	1493.3(4)	0.027(10)	0.00047(18)	¹⁷⁴ Yb	4830.2(4)	0.25(6)	0.0044(11)
¹⁶⁸ Yb	1505.32(6)	0.018(4)	0.00032(7)	¹⁷⁴ Yb	5011.0(4)	0.18(4)	0.0032(7)
¹⁷¹ Yb	1521.197(16)	0.193(24)	0.0034(4)	¹⁷⁴ Yb	5266.3(4)	1.4(6)	0.025(11)
¹⁷³ Yb	1529.19(15)	0.070(10)	0.00123(18)	¹⁷⁴ Yb	5307.5(4)	0.020(5)	0.00035(9)
¹⁷¹ Yb	1529.779(9)	0.095(12)	0.00166(21)	¹⁷¹ Yb	5539.05(5)	0.083(11)	0.00145(19)
¹⁷³ Yb	1533.99(14)	0.103(13)	0.00180(23)	¹⁷¹ Yb	5691.58(9)	0.020(3)	0.00035(5)
¹⁷³ Yb	1552.0(3)	0.032(9)	0.00056(16)	¹⁷⁰ Yb	5712.5(6)	0.056(9)	0.00098(16)
¹⁷¹ Yb	1553.54(25)	0.026(5)	0.00046(9)	¹⁷¹ Yb	5824.85(6)	0.0172(23)	0.00030(4)
¹⁷¹ Yb	1584.114(12)	0.037(6)	0.00065(11)	¹⁷¹ Yb	6009.65(6)	0.0148(19)	0.00026(3)
¹⁷¹ Yb	1589.06(4)	0.037(5)	0.00065(9)	¹⁶⁸ Yb	6779.90(11)	0.058(7)	0.00102(12)
¹⁷¹ Yb	1599.939(16)	0.125(16)	0.0022(3)	Lutetium (Z=71), At. Wt.=174.967(1), σ_γ^Z=76.6(23)			
¹⁷¹ Yb	1608.522(9)	0.081(11)	0.00142(19)	¹⁷⁵ Lu	38.7460(10)	0.38(12)	0.0066(21)
¹⁷¹ Yb	1621.960(12)	0.030(4)	0.00053(7)	¹⁷⁵ Lu	46.4590(10)	0.26(7)	0.0045(12)
¹⁷¹ Yb	1631.792(20)	0.054(7)	0.00095(12)	¹⁷⁵ Lu	66.2400(10)	0.28(4)	0.0048(7)
¹⁷³ Yb	1638.36(17)	0.22(3)	0.0039(5)	¹⁷⁵ Lu	71.5170(10)	3.96(22)	0.069(4)
¹⁷³ Yb	1679.70(14)	0.161(19)	0.0028(3)	¹⁷⁵ Lu	73.1430(10)	0.160(20)	0.0028(4)
¹⁷¹ Yb	1696.12(3)	0.029(4)	0.00051(7)	¹⁷⁶ Lu	88.36(4)	7.1(4) s⁻¹g⁻¹	Abundant
¹⁷¹ Yb	1715.35(4)	0.090(11)	0.00158(19)	¹⁷⁶ Lu	94.129(8)	0.72(4)	0.0125(7)
¹⁷³ Yb	1730.9(3)	0.030(8)	0.00053(14)	¹⁷⁶ Lu	111.705(12)	1.03(5)	0.0178(9)
¹⁷¹ Yb	1742.889(10)	0.024(5)	0.00042(9)	¹⁷⁵ Lu	112.9220(10)	1.15(7)	0.0199(12)
¹⁷¹ Yb	1770.58(4)	0.073(22)	0.0013(4)	¹⁷⁶ Lu	112.9500(10)d	3.47(16)	0.060[<0.1%]
¹⁷³ Yb	1775.1(3)	0.052(11)	0.00091(19)	¹⁷⁶ Lu	115.651(8)	0.144(22)	0.0025(4)
¹⁷¹ Yb	1786.76(3)	0.027(4)	0.00047(7)	¹⁷⁶ Lu	119.836(3)	1.32(22)	0.023(4)
¹⁷¹ Yb	1815.84(3)	0.073(10)	0.00128(18)	¹⁷⁶ Lu	121.620(3)	5.24(17)	0.091(3)
¹⁷¹ Yb	1849.32(4)	0.046(6)	0.00081(11)	¹⁷⁵ Lu	129.7730(10)	0.18(3)	0.0031(5)
¹⁷³ Yb	1859.2(3)	0.051(10)	0.00089(18)	¹⁷⁶ Lu	135.802(19)	0.37(3)	0.0064(5)
¹⁷¹ Yb	1877.64(3)	0.035(5)	0.00061(9)	¹⁷⁶ Lu	138.607(5)	6.79(24)	0.118(4)
¹⁷³ Yb	1920.6(3)	0.040(10)	0.00070(18)	¹⁷⁵ Lu	139.3830(10)	0.25(4)	0.0043(7)
¹⁷¹ Yb	1930.76(5)	0.070(9)	0.00123(16)	¹⁷⁶ Lu	144.745(5)	1.33(8)	0.0230(14)

^A Z	E _γ -keV	σ _γ ^Z (E _γ)-barns	k ₀	^A Z	E _γ -keV	σ _γ ^Z (E _γ)-barns	k ₀
¹⁷⁶ Lu	145.870(4)	1.52(9)	0.0263(16)	¹⁷⁶ Lu	606.65(7)	0.182(15)	0.0032(3)
¹⁷⁶ Lu	147.165(5)	4.96(19)	0.086(3)	¹⁷⁶ Lu	671.908(15)	0.259(21)	0.0045(4)
¹⁷⁶ Lu	147.167(5)	3.7(7)	0.064(12)	¹⁷⁶ Lu	689.77(6)	0.31(5)	0.0054(9)
¹⁷⁶ Lu	150.392(3)	13.8(4)	0.239(7)	¹⁷⁶ Lu	695.033(16)	0.296(25)	0.0051(4)
¹⁷⁵ Lu	153.4670(10)	0.55(5)	0.0095(9)	¹⁷⁵ Lu	709.553(4)	0.21(7)	0.0036(12)
¹⁷⁶ Lu	162.492(4)	5.32(17)	0.092(3)	¹⁷⁶ Lu	716.470(17)	0.189(16)	0.0033(3)
¹⁷⁶ Lu	168.605(6)	0.97(5)	0.0168(9)	¹⁷⁶ Lu	761.564(20)	2.60(9)	0.0450(16)
¹⁷⁶ Lu	171.869(7)	1.74(6)	0.0301(10)	¹⁷⁵ Lu	834.810(3)	0.20(11)	0.0035(19)
¹⁷⁵ Lu	182.4220(10)	0.46(10)	0.0080(17)	¹⁷⁵ Lu	838.643(3)	0.89(10)	0.0154(17)
¹⁷⁶ Lu	185.593(8)	3.42(12)	0.0592(21)	¹⁷⁶ Lu	864.52(8)	0.191(16)	0.0033(3)
¹⁷⁶ Lu	187.970(23)	1.39(6)	0.0241(10)	¹⁷⁶ Lu	899.12(6)	0.423(25)	0.0073(4)
¹⁷⁵ Lu	188.2870(10)	0.29(4)	0.0050(7)	¹⁷⁶ Lu	907.86(6)	0.42(3)	0.0073(5)
¹⁷⁶ Lu	191.492(9)	0.62(12)	0.0107(21)	¹⁷⁶ Lu	907.961(18)	0.35(5)	0.0061(9)
¹⁷⁵ Lu	192.2120(10)	1.08(14)	0.0187(24)	¹⁷⁶ Lu	916.24(4)	0.439(25)	0.0076(4)
¹⁷⁶ Lu	195.565(8)	0.63(5)	0.0109(9)	¹⁷⁵ Lu	1000.846(18)	0.15(10)	0.0026(17)
¹⁷⁵ Lu	197.550(14)	0.30(14)	0.0052(24)	¹⁷⁶ Lu	1036.39(8)	0.169(16)	0.0029(3)
¹⁷⁵ Lu	201.5680(10)	0.78(12)	0.0135(21)	¹⁷⁶ Lu	1061.97(6)	0.45(4)	0.0078(7)
¹⁷⁶ Lu	201.83(4)	37.9(22)	Abundant	¹⁷⁶ Lu	1080.24(6)	0.68(4)	0.0118(7)
¹⁷⁶ Lu	207.797(8)	1.00(5)	0.0173(9)	¹⁷⁶ Lu	1088.11(4)	0.83(4)	0.0144(7)
¹⁷⁶ Lu	208.3660(10)d	6.0(3)	0.104[-0.1%]	¹⁷⁶ Lu	1215.36(13)	0.139(14)	0.00241(24)
¹⁷⁶ Lu	209.492(24)	0.298(25)	0.0052(4)	¹⁷⁶ Lu	1233.84(6)	0.187(19)	0.0032(3)
¹⁷⁶ Lu	212.841(15)	0.16(3)	0.0028(5)	¹⁷⁶ Lu	1305.18(8)	0.36(3)	0.0062(5)
¹⁷⁶ Lu	213.965(8)	0.34(6)	0.0059(10)	¹⁷⁶ Lu	1381.01(6)	0.30(3)	0.0052(5)
¹⁷⁵ Lu	217.0030(10)	0.35(10)	0.0061(17)	¹⁷⁶ Lu	4866.8(5)	0.25(5)	0.0043(9)
¹⁷⁵ Lu	219.2830(20)	0.20(8)	0.0035(14)	¹⁷⁶ Lu	5016.6(5)	0.215(18)	0.0037(3)
¹⁷⁵ Lu	225.4030(10)	1.73(8)	0.0300(14)	¹⁷⁶ Lu	5023.6(3)	0.176(24)	0.0030(4)
¹⁷⁵ Lu	227.9970(10)	0.57(7)	0.0099(12)	¹⁷⁶ Lu	5319.45(24)	0.167(19)	0.0029(3)
¹⁷⁶ Lu	228.708(10)	0.178(21)	0.0031(4)	¹⁷⁶ Lu	5323.12(13)	0.145(15)	0.0025(3)
¹⁷⁵ Lu	233.7410(20)	0.41(10)	0.0071(17)	¹⁷⁵ Lu	5331.80(20)	0.16(4)	0.0028(7)
¹⁷⁶ Lu	235.892(15)	0.81(4)	0.0140(7)	¹⁷⁵ Lu	5331.94(20)	0.19(4)	0.0033(7)
¹⁷⁵ Lu	238.6710(10)	0.20(6)	0.0035(10)	¹⁷⁶ Lu	5343.91(25)	0.26(3)	0.0045(5)
¹⁷⁶ Lu	244.310(12)	0.45(8)	0.0078(14)	¹⁷⁶ Lu	5465.7(3)	0.218(16)	0.0038(3)
¹⁷⁶ Lu	247.255(15)	0.247(23)	0.0043(4)	¹⁷⁶ Lu	5570.12(10)	0.385(24)	0.0067(4)
¹⁷⁵ Lu	251.1990(20)	0.16(3)	0.0028(5)	¹⁷⁶ Lu	5601.87(25)	0.327(25)	0.0057(4)
¹⁷⁶ Lu	259.401(16)	1.89(8)	0.0327(14)	¹⁷⁶ Lu	5728.00(10)	0.23(3)	0.0040(5)
¹⁷⁵ Lu	263.7290(10)	0.59(10)	0.0102(17)	¹⁷⁶ Lu	5769.72(10)	0.184(18)	0.0032(3)
¹⁷⁶ Lu	264.581(6)	0.76(11)	0.0132(19)	¹⁷⁶ Lu	6803.92(9)	0.38(8)	0.0066(14)
¹⁷⁶ Lu	268.788(5)	3.64(13)	0.0630(23)	Hafnium (Z=72), At.Wt.=178.49(2), σ_γ^Z=119(3)			
¹⁷⁵ Lu	277.6830(10)	0.20(6)	0.0035(10)	¹⁷⁸ Hf	45.8570(10)	1.21(7)	0.0205(12)
¹⁷⁵ Lu	284.6410(10)	0.75(6)	0.0130(10)	¹⁷⁷ Hf	62.820(21)	5.26(16)	0.089(3)
¹⁷⁶ Lu	301.098(6)	0.73(4)	0.0126(7)	¹⁷⁷ Hf	93.182(6)	13.3(9)	0.226(15)
¹⁷⁶ Lu	306.84(4)	45.2(24) s ⁻¹ g ⁻¹	Abundant	¹⁷⁹ Hf	93.3240(20)	0.80(5)	0.0136(9)
¹⁷⁵ Lu	310.1870(10)	1.49(8)	0.0258(14)	¹⁷⁸ Hf	105.8940(20)	0.335(10)	0.00569(17)
¹⁷⁶ Lu	313.350(8)	0.40(3)	0.0069(5)	¹⁷⁸ Hf	122.8970(10)	0.432(16)	0.0073(3)
¹⁷⁶ Lu	319.036(8)	3.83(13)	0.0663(23)	¹⁷⁴ Hf	125.7(10)	0.2000(20)	0.00340(3)
¹⁷⁶ Lu	322.865(19)	0.31(3)	0.0054(5)	¹⁷⁷ Hf	144.530(3)	0.384(13)	0.00652(22)
¹⁷⁶ Lu	329.59(3)	0.181(21)	0.0031(4)	¹⁷⁸ Hf	161.1890(20)	0.57(10)	0.0097(17)
¹⁷⁵ Lu	335.8480(20)	1.32(8)	0.0229(14)	¹⁷⁸ Hf	193.3100(10)	1.1(3)	0.019(5)
¹⁷⁶ Lu	336.323(15)	0.19(3)	0.0033(5)	¹⁷⁸ Hf	202.2840(20)	0.65(13)	0.0110(22)
¹⁷⁶ Lu	346.37(3)	0.35(6)	0.0061(10)	¹⁷⁷ Hf	213.439(7)	29.3(7)	0.497(12)
¹⁷⁶ Lu	348.084(9)	0.84(4)	0.0145(7)	¹⁷⁸ Hf	214.3410(20)	5.7(6)	0.097(10)
¹⁷⁶ Lu	360.096(10)	0.29(9)	0.0050(16)	¹⁷⁸ Hf	214.3410(20)d	16.3(3)	0.277[99%]
¹⁷⁶ Lu	364.58(4)	0.62(3)	0.0107(5)	¹⁷⁹ Hf	215.426(8)	2.77(17)	0.047(3)
¹⁷⁶ Lu	367.433(11)	2.23(8)	0.0386(14)	¹⁷⁹ Hf	235.020(7)	0.38(9)	0.0065(15)
¹⁷⁶ Lu	393.389(11)	0.54(3)	0.0094(5)	¹⁷⁸ Hf	239.1660(10)	0.293(24)	0.0050(4)
¹⁷⁶ Lu	413.665(13)	0.93(4)	0.0161(7)	¹⁷⁷ Hf	244.3130(20)	0.58(4)	0.0098(7)
¹⁷⁶ Lu	430.452(15)	0.147(21)	0.0025(4)	¹⁷⁷ Hf	244.544(13)	0.97(14)	0.0165(24)
¹⁷⁶ Lu	436.505(13)	0.145(20)	0.0025(4)	¹⁷⁷ Hf	245.2950(20)	0.58(4)	0.0098(7)
¹⁷⁶ Lu	457.944(15)	8.3(3)	0.144(5)	¹⁷⁷ Hf	256.6010(20)	0.426(20)	0.0072(3)
¹⁷⁶ Lu	475.46(3)	0.287(16)	0.0050(3)	¹⁷⁸ Hf	258.6230(20)	0.44(10)	0.0075(17)
¹⁷⁵ Lu	520.5500(20)	0.20(4)	0.0035(7)	¹⁷⁷ Hf	273.166(3)	0.305(16)	0.0052(3)
¹⁷⁵ Lu	527.5090(20)	0.32(5)	0.0055(9)	¹⁷⁷ Hf	277.2080(20)	0.47(3)	0.0080(5)
¹⁷⁶ Lu	544.602(18)	0.210(13)	0.00364(23)	¹⁷⁷ Hf	289.5570(20)	0.67(4)	0.0114(7)
¹⁷⁶ Lu	547.866(16)	0.306(17)	0.0053(3)	¹⁷⁸ Hf	303.9880(20)	3.38(9)	0.0574(15)
¹⁷⁶ Lu	550.288(15)	0.490(21)	0.0085(4)	¹⁷⁷ Hf	325.559(4)	6.69(17)	0.114(3)
¹⁷⁶ Lu	552.073(15)	0.67(3)	0.0116(5)	¹⁷⁹ Hf	332.275(11)	0.73(17)	0.012(3)
¹⁷⁵ Lu	563.9420(20)	0.51(4)	0.0088(7)	¹⁷⁷ Hf	339.1990(20)	1.28(6)	0.0217(10)
¹⁷⁵ Lu	578.198(3)	0.20(8)	0.0035(14)	¹⁷⁷ Hf	348.369(4)	0.60(8)	0.0102(14)

^A Z	E _γ -keV	σ _γ ^Z (E _γ)-barns	k ₀	^A Z	E _γ -keV	σ _γ ^Z (E _γ)-barns	k ₀
¹⁷⁷ Hf	426.380(5)	0.35(3)	0.0059(5)	¹⁸¹ Ta	72.932(4)	0.054(15)	0.00090(25)
¹⁷⁷ Hf	497.893(3)	1.11(11)	0.0188(19)	¹⁸¹ Ta	73.519(4)	0.06(3)	0.0010(5)
¹⁷⁶ Hf	508.29(9)	1.05(6)	0.0178(10)	¹⁸¹ Ta	74.2680(20)	0.077(22)	0.0013(4)
¹⁷⁷ Hf	547.374(5)	0.40(4)	0.0068(7)	¹⁸¹ Ta	76.549(6)	0.029(13)	0.00049(22)
¹⁷⁷ Hf	596.894(4)	0.34(13)	0.0058(22)	¹⁸¹ Ta	82.876(4)	0.029(13)	0.00049(22)
¹⁷⁸ Hf	729.515(4)	0.53(5)	0.0090(9)	¹⁸¹ Ta	92.480(3)	0.065(9)	0.00109(15)
¹⁷⁷ Hf	921.822(5)	0.84(5)	0.0143(9)	¹⁸¹ Ta	94.1680(20)	0.051(7)	0.00085(12)
¹⁷⁷ Hf	961.919(5)	0.76(7)	0.0129(12)	¹⁸¹ Ta	95.156(3)	0.081(9)	0.00136(15)
¹⁷⁷ Hf	970.066(7)	0.32(8)	0.0054(14)	¹⁸¹ Ta	97.467(3)	0.065(9)	0.00109(15)
¹⁷⁸ Hf	1003.650(4)	0.89(5)	0.0151(9)	¹⁸¹ Ta	97.8320(20)	0.139(7)	0.00233(12)
¹⁷⁷ Hf	1016.663(6)	0.30(13)	0.0051(22)	¹⁸¹ Ta	99.8310(20)	0.127(7)	0.00213(12)
¹⁷⁹ Hf	1059.66(4)	0.32(3)	0.0054(5)	¹⁸¹ Ta	100.5540(20)	0.060(11)	0.00100(18)
¹⁷⁹ Hf	1065.45(3)	1.94(5)	0.0329(9)	¹⁸¹ Ta	104.1130(20)	0.037(6)	0.00062(10)
¹⁷⁷ Hf	1077.844(5)	2.40(6)	0.0407(10)	¹⁸¹ Ta	107.863(3)	0.131(14)	0.00219(23)
¹⁷⁷ Hf	1081.454(6)	2.82(7)	0.0479(12)	¹⁸¹ Ta	114.3150(10)	0.280(9)	0.00469(15)
¹⁷⁷ Hf	1102.824(5)	2.96(8)	0.0503(14)	¹⁸¹ Ta	114.3760(20)	0.110(20)	0.0018(3)
¹⁷⁷ Hf	1143.737(7)	1.84(6)	0.0312(10)	¹⁸¹ Ta	114.674(3)	0.193(20)	0.0032(3)
¹⁷⁷ Hf	1167.072(6)	3.95(10)	0.0671(17)	¹⁸¹ Ta	118.8950(20)	0.108(8)	0.00181(13)
¹⁷⁷ Hf	1174.635(5)	4.8(7)	0.081(12)	¹⁸¹ Ta	119.516(3)	0.039(6)	0.00065(10)
¹⁷⁷ Hf	1175.357(7)	2.6(5)	0.044(9)	¹⁸¹ Ta	119.6980(20)	0.038(6)	0.00064(10)
¹⁷⁷ Hf	1183.504(8)	1.42(5)	0.0241(9)	¹⁸¹ Ta	121.5340(20)	0.031(3)	0.00052(5)
¹⁷⁹ Hf	1197.92(8)	0.44(6)	0.0075(10)	¹⁸¹ Ta	122.613(3)	0.037(6)	0.00062(10)
¹⁷⁷ Hf	1205.975(5)	1.26(23)	0.021(4)	¹⁸¹ Ta	122.675(3)	0.092(4)	0.00154(7)
¹⁷⁷ Hf	1207.213(5)	3.9(3)	0.066(5)	¹⁸¹ Ta	122.9730(20)	0.075(9)	0.00126(15)
¹⁷⁷ Hf	1226.532(6)	1.30(5)	0.0221(9)	¹⁸¹ Ta	125.126(3)	0.030(4)	0.00050(7)
¹⁷⁷ Hf	1229.287(8)	4.26(11)	0.0723(19)	¹⁸¹ Ta	133.8770(20)	0.63(7)	0.0106(12)
¹⁷⁷ Hf	1232.172(5)	1.35(6)	0.0229(10)	¹⁸¹ Ta	139.4560(20)	0.094(10)	0.00157(17)
¹⁷⁷ Hf	1247.379(5)	0.49(4)	0.0083(7)	¹⁸¹ Ta	139.6610(20)	0.029(3)	0.00049(5)
¹⁷⁷ Hf	1254.913(7)	0.40(4)	0.0068(7)	¹⁸¹ Ta	141.2450(20)	0.062(9)	0.00104(15)
¹⁷⁷ Hf	1269.372(6)	2.26(7)	0.0384(12)	¹⁸¹ Ta	142.261(5)	0.042(13)	0.00070(22)
¹⁷⁷ Hf	1291.282(6)	0.99(5)	0.0168(9)	¹⁸¹ Ta	143.156(7)	0.061(9)	0.00102(15)
¹⁷⁷ Hf	1310.071(5)	1.45(5)	0.0246(9)	¹⁸¹ Ta	146.7740(20)	0.141(4)	0.00236(7)
¹⁷⁷ Hf	1330.109(5)	2.08(8)	0.0353(14)	¹⁸¹ Ta	154.0850(20)	0.082(3)	0.00137(5)
¹⁷⁷ Hf	1333.832(5)	1.71(9)	0.0290(15)	¹⁸¹ Ta	156.0880(20)	0.233(6)	0.00390(10)
¹⁷⁷ Hf	1340.447(6)	2.38(10)	0.0404(17)	¹⁸¹ Ta	156.2300(20)	0.046(3)	0.00077(5)
¹⁷⁷ Hf	1344.841(5)	0.59(5)	0.0100(9)	¹⁸¹ Ta	159.048(3)	0.0449(23)	0.00075(4)
¹⁷⁷ Hf	1403.267(20)	0.51(4)	0.0087(7)	¹⁸¹ Ta	167.413(3)	0.031(3)	0.00052(5)
¹⁷⁷ Hf	1420.651(6)	1.81(8)	0.0307(14)	¹⁸¹ Ta	168.130(4)	0.033(9)	0.00055(15)
¹⁷⁷ Hf	1496.448(21)	0.44(3)	0.0075(5)	¹⁸¹ Ta	171.580(3)d	0.005400(11)	9.044E-5[65%]
¹⁷⁷ Hf	1542.416(7)	0.55(8)	0.0093(14)	¹⁸¹ Ta	171.580(3)	0.029(4)	0.00049(7)
¹⁷⁷ Hf	1649.794(6)	0.367(22)	0.0062(4)	¹⁸¹ Ta	173.2050(20)	1.210(25)	0.0203(4)
¹⁷⁸ Hf	1649.81(10)	0.46(4)	0.0078(7)	¹⁸¹ Ta	178.6250(20)	0.072(6)	0.00121(10)
¹⁷⁷ Hf	1725.094(10)	0.46(5)	0.0078(9)	¹⁸¹ Ta	190.334(3)	0.183(7)	0.00306(12)
¹⁷⁷ Hf	1848.821(8)	0.46(5)	0.0078(9)	¹⁸¹ Ta	195.1080(20)	0.075(4)	0.00126(7)
¹⁸⁰ Hf	1895.38(16)	0.54(5)	0.0092(9)	¹⁸¹ Ta	210.5460(20)	0.064(4)	0.00107(7)
¹⁷⁷ Hf	1904.272(10)	0.71(6)	0.0121(10)	¹⁸¹ Ta	214.2070(20)	0.0481(23)	0.00081(4)
¹⁷⁷ Hf	1927.998(7)	0.30(5)	0.0051(9)	¹⁸¹ Ta	233.7080(20)	0.065(3)	0.00109(5)
¹⁷⁷ Hf	1957.294(12)	0.31(4)	0.0053(7)	¹⁸¹ Ta	237.2880(20)	0.050(6)	0.00084(10)
¹⁷⁸ Hf	3497.81(25)	0.31(5)	0.0053(9)	¹⁸¹ Ta	244.809(4)	0.032(3)	0.00054(5)
¹⁷⁸ Hf	4336.18(4)	0.35(4)	0.0059(7)	¹⁸¹ Ta	252.7710(20)	0.034(8)	0.00057(13)
¹⁷⁸ Hf	4343.69(4)	0.44(5)	0.0075(9)	¹⁸¹ Ta	260.094(4)	0.052(17)	0.0009(3)
¹⁷⁹ Hf	4915.2(6)	0.35(5)	0.0059(9)	¹⁸¹ Ta	267.907(3)	0.027(4)	0.00045(7)
¹⁷⁷ Hf	5068.3(5)	0.32(5)	0.0054(9)	¹⁸¹ Ta	270.4030(20)	2.60(6)	0.0435(10)
¹⁷⁷ Hf	5260.9(5)	0.36(6)	0.0061(10)	¹⁸¹ Ta	287.131(3)	0.054(6)	0.00090(10)
¹⁷⁷ Hf	5294.9(5)	0.34(5)	0.0058(9)	¹⁸¹ Ta	290.362(3)	0.027(7)	0.00045(12)
¹⁷⁷ Hf	5575.22(16)	0.41(4)	0.0070(7)	¹⁸¹ Ta	297.125(3)	0.17(3)	0.0028(5)
¹⁷⁹ Hf	5647.71(11)	0.38(4)	0.0065(7)	¹⁸¹ Ta	322.554(4)	0.048(3)	0.00080(5)
¹⁸⁰ Hf	5649.60(21)	0.33(18)	0.006(3)	¹⁸¹ Ta	346.465(5)	0.110(6)	0.00184(10)
¹⁸⁰ Hf	5695.48(17)	1.09(9)	0.0185(15)	¹⁸¹ Ta	360.518(3)	0.177(7)	0.00296(12)
¹⁷⁸ Hf	5723.809(22)	1.97(10)	0.0334(17)	¹⁸¹ Ta	373.881(6)	0.052(3)	0.00087(5)
¹⁷⁷ Hf	5807.42(16)	0.35(5)	0.0059(9)	¹⁸¹ Ta	377.2460(20)	0.127(4)	0.00213(7)
¹⁷⁷ Hf	6111.85(16)	0.92(6)	0.0156(10)	¹⁸¹ Ta	382.203(3)	0.074(3)	0.00124(5)
¹⁷⁷ Hf	6357.14(16)	0.32(5)	0.0054(9)	¹⁸¹ Ta	401.238(3)	0.044(3)	0.00074(5)
Tantalum (Z=73), At.Wt.=180.9479(1), σ_γ^Z=20.6(5)				¹⁸¹ Ta	402.623(3)	1.180(23)	0.0198(4)
¹⁸¹ Ta	47.8120(20)	0.13(3)	0.0022(5)	¹⁸¹ Ta	443.6080(20)	0.036(3)	0.00060(5)
¹⁸¹ Ta	54.4710(20)	0.052(13)	0.00087(22)	¹⁸¹ Ta	473.803(6)	0.032(3)	0.00054(5)
¹⁸¹ Ta	59.693(3)	0.042(13)	0.00070(22)	¹⁸¹ Ta	478.685(5)	0.054(3)	0.00090(5)
¹⁸¹ Ta	71.900(4)	0.060(15)	0.00100(25)	¹⁸¹ Ta	480.034(3)	0.091(4)	0.00152(7)

^A Z	E _γ -keV	σ _γ ^Z (E _γ)-barns	k ₀	^A Z	E _γ -keV	σ _γ ^Z (E _γ)-barns	k ₀
¹⁸¹ Ta	489.590(4)	0.027(4)	0.00045(7)	¹⁸² W	291.724(7)	0.0453(19)	0.00075(3)
¹⁸¹ Ta	499.118(6)	0.050(4)	0.00084(7)	¹⁸⁶ W	294.73(8)	0.0097(16)	1.6(3)E-4
¹⁸¹ Ta	501.068(3)	0.029(3)	0.00049(5)	¹⁸³ W	294.958(14)	0.0106(11)	1.75(18)E-4
¹⁸¹ Ta	509.967(5)	0.054(13)	0.00090(22)	¹⁸⁶ W	303.25(4)	0.044(3)	0.00073(5)
¹⁸¹ Ta	512.355(4)	0.165(9)	0.00276(15)	¹⁸² W	313.0160(10)	0.054(4)	0.00089(7)
¹⁸¹ Ta	514.110(4)	0.033(4)	0.00055(7)	¹⁸³ W	318.015(12)	0.021(3)	0.00035(5)
¹⁸¹ Ta	530.593(4)	0.0266(23)	0.00045(4)	¹⁸⁶ W	354.78(6)	0.0452(24)	0.00075(4)
¹⁸¹ Ta	603.15(3)	0.035(3)	0.00059(5)	¹⁸⁰ W	365.44(11)	0.0155(15)	0.000256(25)
¹⁸¹ Ta	3982.2(3)	0.032(7)	0.00054(12)	¹⁸⁶ W	376.70(5)	0.0453(18)	0.00075(3)
¹⁸¹ Ta	4045.81(23)	0.030(3)	0.00050(5)	¹⁸⁶ W	390.59(11)	0.0126(12)	2.08(20)E-4
¹⁸¹ Ta	4053.82(22)	0.034(3)	0.00057(5)	¹⁸⁶ W	423.75(7)	0.0497(22)	0.00082(4)
¹⁸¹ Ta	4219.98(25)	0.037(4)	0.00062(7)	¹⁸⁶ W	473.88(7)	0.055(5)	0.00091(8)
¹⁸¹ Ta	4315.43(19)	0.084(7)	0.00141(12)	¹⁸⁶ W	479.550(22)d	2.59(5)	0.0427[1.4%]
¹⁸¹ Ta	4443.9(3)	0.031(4)	0.00052(7)	¹⁸⁶ W	494.64(7)	0.0123(16)	2.0(3)E-4
¹⁸¹ Ta	4482.95(25)	0.042(6)	0.00070(10)	¹⁸⁶ W	500.08(6)	0.0491(23)	0.00081(4)
¹⁸¹ Ta	4536.05(25)	0.032(4)	0.00054(7)	¹⁸⁶ W	531.17(7)	0.052(3)	0.00086(5)
¹⁸¹ Ta	4566.6(3)	0.032(4)	0.00054(7)	¹⁸⁶ W	541.09(7)	0.0190(23)	0.00031(4)
¹⁸¹ Ta	4579.5(3)	0.035(4)	0.00059(7)	¹⁸⁶ W	547.81(17)	0.022(4)	0.00036(7)
¹⁸¹ Ta	4618.08(22)	0.044(4)	0.00074(7)	¹⁸⁶ W	551.52(4)d	0.603(14)	0.00994[1.4%]
¹⁸¹ Ta	4691.73(25)	0.040(4)	0.00067(7)	¹⁸⁶ W	557.16(5)	0.125(5)	0.00206(8)
¹⁸¹ Ta	4781.95(18)	0.105(7)	0.00176(12)	¹⁸⁴ W	569.65(22)	0.0166(17)	0.00027(3)
¹⁸¹ Ta	4792.76(25)	0.048(4)	0.00080(7)	¹⁸⁶ W	577.30(5)	0.191(5)	0.00315(8)
¹⁸¹ Ta	4802.55(25)	0.037(4)	0.00062(7)	¹⁸⁴ W	579.8(3)	0.021(10)	0.00035(16)
¹⁸¹ Ta	4832.97(25)	0.030(3)	0.00050(5)	¹⁸⁴ W	580.49(23)	0.021(10)	0.00035(16)
¹⁸¹ Ta	4980.12(22)	0.033(3)	0.00055(5)	¹⁸⁶ W	588.34(7)	0.0216(19)	0.00036(3)
¹⁸¹ Ta	5005.52(21)	0.042(3)	0.00070(5)	¹⁸³ W	607.60(5)	0.0112(16)	1.8(3)E-4
¹⁸¹ Ta	5245.79(6)	0.051(4)	0.00085(7)	¹⁸⁶ W	611.30(5)	0.066(3)	0.00109(5)
¹⁸¹ Ta	5343.26(6)	0.048(4)	0.00080(7)	¹⁸⁶ W	616.20(6)	0.059(3)	0.00097(5)
¹⁸¹ Ta	5792.39(6)	0.034(3)	0.00057(5)	¹⁸⁶ W	618.26(4)d	0.746(17)	0.0123[1.4%]
¹⁸¹ Ta	5964.95(6)	0.138(8)	0.00231(13)	¹⁸⁶ W	625.519(10)d	0.129(3)	0.00213[1.4%]
¹⁸¹ Ta	6062.78(6)	0.087(4)	0.00146(7)	¹⁸⁶ W	629.19(17)	0.022(3)	0.00036(5)
Tungsten (Z=74), At.Wt.=183.84(1), σ_γ^Z=18.39(16)				¹⁸⁶ W	635.35(5)	0.036(4)	0.00059(7)
¹⁸² W	46.4840(10)	0.192(10)	0.00316(16)	¹⁸⁴ W	636.4(4)	0.044(20)	0.0007(3)
¹⁸² W	52.5290(10)	0.128(11)	0.00211(18)	¹⁸⁴ W	640.02(24)	0.055(25)	0.0009(4)
¹⁸⁶ W	59.03(4)	0.208(7)	0.00343(12)	¹⁸⁶ W	640.43(7)	0.032(3)	0.00053(5)
¹⁸⁶ W	72.002(4)d	1.32(3)	0.0218[1.4%]	¹⁸⁶ W	657.54(7)	0.083(5)	0.00137(8)
¹⁸⁶ W	77.39(3)	0.134(5)	0.00221(8)	¹⁸⁶ W	661.36(8)	0.032(4)	0.00053(7)
¹⁸² W	84.7130(10)	0.0261(16)	0.00043(3)	¹⁸⁴ W	663.49(21)	0.029(3)	0.00048(5)
¹⁸² W	99.0790(10)	0.155(13)	0.00256(21)	¹⁸⁶ W	670.34(5)	0.0452(25)	0.00075(4)
¹⁸⁶ W	101.80(5)	0.0129(22)	2.1(4)E-4	¹⁸⁴ W	674.5(3)	0.019(9)	0.00031(15)
¹⁸² W	107.9320(10)	0.144(12)	0.00237(20)	¹⁸⁶ W	685.73(4)d	3.24(7)	0.0534[1.4%]
¹⁸² W	109.738(7)	0.0201(16)	0.00033(3)	¹⁸⁶ W	694.38(5)	0.073(3)	0.00120(5)
¹⁸³ W	111.216(9)	0.195(6)	0.00321(10)	¹⁸² W	694.64(4)	0.0230(19)	0.00038(3)
¹⁸⁶ W	124.05(5)	0.051(11)	0.00084(18)	¹⁸² W	696.77(5)	0.022(6)	0.00036(10)
¹⁸⁶ W	127.43(4)	0.129(5)	0.00213(8)	¹⁸³ W	710.28(5)	0.0118(17)	1.9(3)E-4
¹⁸⁶ W	128.92(6)	0.0207(24)	0.00034(4)	¹⁸³ W	711.59(6)	0.0108(15)	1.78(25)E-4
¹⁸⁶ W	134.247(7)d	1.050(20)	0.0173[1.4%]	¹⁸³ W	724.39(3)	0.0179(23)	0.00030(4)
¹⁸⁶ W	142.90(8)	0.0206(18)	0.00034(3)	¹⁸⁶ W	725.94(6)	0.023(4)	0.00038(7)
¹⁸⁶ W	145.79(3)	0.970(21)	0.0160(4)	¹⁸⁶ W	738.73(5)	0.040(3)	0.00066(5)
¹⁸⁶ W	149.05(7)	0.0393(22)	0.00065(4)	¹⁸⁴ W	744.86(24)	0.030(14)	0.00049(23)
¹⁸⁶ W	157.46(4)	0.0319(14)	0.000526(23)	¹⁸⁶ W	745.80(6)	0.053(3)	0.00087(5)
¹⁸² W	160.5280(10)	0.0183(12)	0.000302(20)	¹⁸⁴ W	757.2(3)	0.048(22)	0.0008(4)
¹⁸² W	162.315(8)	0.187(5)	0.00308(8)	¹⁸³ W	757.324(23)	0.028(3)	0.00046(5)
¹⁸⁶ W	171.69(7)	0.0097(10)	1.60(16)E-4	¹⁸⁶ W	762.78(5)	0.047(4)	0.00077(7)
¹⁸⁴ W	173.680(20)	0.0155(16)	0.00026(3)	¹⁸⁴ W	768.33(22)	0.015(7)	2.5(12)E-4
¹⁸⁶ W	197.56(16)	0.027(5)	0.00045(8)	¹⁸⁶ W	772.89(5)d	0.490(10)	0.00808[1.4%]
¹⁸⁶ W	201.44(5)	0.319(8)	0.00526(13)	¹⁸⁶ W	782.12(6)	0.22(3)	0.0036(5)
¹⁸⁶ W	204.83(4)	0.148(4)	0.00244(7)	¹⁸⁶ W	788.79(7)	0.070(5)	0.00115(8)
¹⁸² W	208.817(7)	0.0231(25)	0.00038(4)	¹⁸³ W	792.059(16)	0.119(6)	0.00196(10)
¹⁸² W	209.876(9)	0.014(3)	2.3(5)E-4	¹⁸⁶ W	803.33(6)	0.034(3)	0.00056(5)
¹⁸³ W	215.340(13)	0.0107(10)	1.76(16)E-4	¹⁸⁶ W	814.20(6)	0.0436(25)	0.00072(4)
¹⁸⁶ W	225.86(4)	0.113(17)	0.0019(3)	¹⁸⁶ W	816.13(5)	0.104(4)	0.00171(7)
¹⁸³ W	226.743(10)	0.067(16)	0.0011(3)	¹⁸² W	817.557(17)	0.0157(13)	0.000259(21)
¹⁸⁶ W	227.34(7)	0.024(4)	0.00040(7)	¹⁸⁴ W	822.76(20)	0.0176(24)	0.00029(4)
¹⁸² W	246.0600(10)	0.0280(12)	0.000462(20)	¹⁸⁶ W	831.65(10)	0.092(16)	0.0015(3)
¹⁸³ W	252.854(11)	0.101(3)	0.00166(5)	¹⁸⁴ W	838.5(4)	0.014(6)	2.3(10)E-4
¹⁸⁶ W	273.10(5)	0.272(7)	0.00448(12)	¹⁸⁶ W	840.18(5)	0.143(5)	0.00236(8)
¹⁸⁶ W	289.94(5)	0.0603(22)	0.00099(4)	¹⁸² W	846.33(6)	0.0221(22)	0.00036(4)

A	Z	E_{γ} -keV	$\sigma_{\gamma}^Z(E_{\gamma})$ -barns	k_0	A	Z	E_{γ} -keV	$\sigma_{\gamma}^Z(E_{\gamma})$ -barns	k_0
¹⁸⁶ W		866.18(7)	0.068(3)	0.00112(5)	¹⁸³ W		1995.48(21)	0.0103(20)	1.7(3)E-4
¹⁸⁶ W		872.64(8)	0.040(3)	0.00066(5)	¹⁸³ W		2014.85(5)	0.0104(15)	1.71(25)E-4
¹⁸⁶ W		877.51(8)	0.030(3)	0.00049(5)	¹⁸³ W		2035.64(17)	0.025(3)	0.00041(5)
¹⁸⁶ W		880.89(9)	0.045(3)	0.00074(5)	¹⁸³ W		2135.08(21)	0.013(3)	2.1(5)E-4
¹⁸² W		888.08(3)	0.076(13)	0.00125(21)	¹⁸³ W		2183.29(8)	0.022(3)	0.00036(5)
¹⁸⁴ W		888.9(3)	0.026(12)	0.00043(20)	¹⁸³ W		2284.32(19)	0.018(4)	0.00030(7)
¹⁸³ W		891.27(4)	0.063(4)	0.00104(7)	¹⁸⁶ W		2293.1(7)	0.011(3)	1.8(5)E-4
¹⁸⁶ W		891.59(6)	0.136(5)	0.00224(8)	¹⁸⁶ W		2367.1(4)	0.030(16)	0.0005(3)
¹⁸³ W		894.735(16)	0.075(4)	0.00124(7)	¹⁸³ W		2369.9(3)	0.018(4)	0.00030(7)
¹⁸³ W		903.274(17)	0.115(5)	0.00190(8)	¹⁸⁶ W		2481.30(25)	0.031(4)	0.00051(7)
¹⁸⁶ W		909.04(10)	0.092(4)	0.00152(7)	¹⁸⁶ W		2556.0(3)	0.021(4)	0.00035(7)
¹⁸⁴ W		912.1(3)	0.028(3)	0.00046(5)	¹⁸⁶ W		2584.20(18)	0.031(4)	0.00051(7)
¹⁸⁶ W		913.63(6)	0.030(3)	0.00049(5)	¹⁸⁶ W		2689.5(3)	0.024(4)	0.00040(7)
¹⁸² W		927.294(18)	0.0235(18)	0.00039(3)	¹⁸⁶ W		2708.4(3)	0.026(4)	0.00043(7)
¹⁸⁶ W		930.08(8)	0.018(4)	0.00030(7)	¹⁸⁶ W		2727.5(4)	0.021(11)	0.00035(18)
¹⁸⁶ W		933.46(7)	0.0133(11)	2.19(18)E-4	¹⁸⁶ W		2738.4(3)	0.032(4)	0.00053(7)
¹⁸⁶ W		936.54(8)	0.0130(11)	2.14(18)E-4	¹⁸⁶ W		2760.3(3)	0.033(4)	0.00054(7)
¹⁸² W		941.02(5)	0.0117(11)	1.93(18)E-4	¹⁸⁶ W		2831.98(20)	0.023(4)	0.00038(7)
¹⁸⁶ W		941.04(8)	0.0276(13)	0.000455(21)	¹⁸⁶ W		2849.3(3)	0.033(4)	0.00054(7)
¹⁸² W		960.29(17)	0.0101(21)	1.7(4)E-4	¹⁸⁶ W		2939.4(4)	0.014(4)	2.3(7)E-4
¹⁸⁴ W		976.2(3)	0.016(7)	0.00026(12)	¹⁸⁶ W		3055.01(20)	0.0290(25)	0.00048(4)
¹⁸⁶ W		979.68(16)	0.016(16)	0.0003(3)	¹⁸⁶ W		3097.3(4)	0.015(3)	2.5(5)E-4
¹⁸² W		979.871(18)	0.102(10)	0.00168(16)	¹⁸⁶ W		3114.78(20)	0.025(3)	0.00041(5)
¹⁸⁶ W		989.11(7)	0.036(4)	0.00059(7)	¹⁸⁶ W		3148.2(5)	0.086(19)	0.0014(3)
¹⁸⁶ W		1004.94(8)	0.015(6)	2.5(10)E-4	¹⁸⁶ W		3153.9(10)	0.061(20)	0.0010(3)
¹⁸⁴ W		1005.9(4)	0.022(10)	0.00036(16)	¹⁸⁶ W		3191.92(25)	0.037(3)	0.00061(5)
¹⁸³ W		1010.177(23)	0.036(3)	0.00059(5)	¹⁸⁶ W		3207.0(3)	0.030(4)	0.00049(7)
¹⁸⁶ W		1012.05(6)	0.041(5)	0.00068(8)	¹⁸⁶ W		3225.15(17)	0.042(6)	0.00069(10)
¹⁸⁶ W		1018.43(8)	0.036(4)	0.00059(7)	¹⁸⁶ W		3267.1(5)	0.0101(24)	1.7(4)E-4
¹⁸⁶ W		1025.94(12)	0.033(8)	0.00054(13)	¹⁸⁶ W		3314.4(4)	0.015(3)	2.5(5)E-4
¹⁸² W		1026.373(17)	0.161(15)	0.00265(25)	¹⁸⁶ W		3376.15(18)	0.041(4)	0.00068(7)
¹⁸⁴ W		1031.3(3)	0.031(14)	0.00051(23)	¹⁸⁶ W		3423.0(4)	0.030(3)	0.00049(5)
¹⁸⁶ W		1057.51(7)	0.029(3)	0.00048(5)	¹⁸⁶ W		3443.2(4)	0.039(12)	0.00064(20)
¹⁸⁶ W		1071.09(5)	0.053(3)	0.00087(5)	¹⁸⁶ W		3452.8(9)	0.055(10)	0.00091(16)
¹⁸⁶ W		1082.34(8)	0.061(4)	0.00101(7)	¹⁸⁶ W		3469.40(14)	0.103(6)	0.00170(10)
¹⁸⁶ W		1084.97(12)	0.022(3)	0.00036(5)	¹⁸⁶ W		3492.67(17)	0.051(4)	0.00084(7)
¹⁸² W		1100.73(13)	0.024(5)	0.00040(8)	¹⁸⁶ W		3510.72(19)	0.033(4)	0.00054(7)
¹⁸⁶ W		1103.58(21)	0.050(13)	0.00082(21)	¹⁸⁶ W		3529.69(18)	0.040(4)	0.00066(7)
¹⁸⁶ W		1106.96(20)	0.027(3)	0.00045(5)	¹⁸⁶ W		3534.56(17)	0.063(5)	0.00104(8)
¹⁸³ W		1121.392(24)	0.0144(15)	2.37(25)E-4	¹⁸⁶ W		3561.14(14)	0.060(4)	0.00099(7)
¹⁸⁴ W		1125.3(3)	0.046(21)	0.0008(4)	¹⁸⁶ W		3577.2(4)	0.016(4)	0.00026(7)
¹⁸⁶ W		1134.90(7)	0.027(3)	0.00045(5)	¹⁸³ W		3696.2(4)	0.011(3)	1.8(5)E-4
¹⁸⁶ W		1139.48(5)	0.031(3)	0.00051(5)	¹⁸⁶ W		3710.1(4)	0.034(8)	0.00056(13)
¹⁸⁶ W		1153.37(12)	0.014(8)	2.3(13)E-4	¹⁸⁶ W		3739.05(17)	0.069(4)	0.00114(7)
¹⁸⁴ W		1153.5(3)	0.011(5)	1.8(8)E-4	¹⁸⁶ W		3760.9(3)	0.026(3)	0.00043(5)
¹⁸⁴ W		1180.8(3)	0.08(4)	0.0013(7)	¹⁸⁶ W		3774.59(21)	0.026(3)	0.00043(5)
¹⁸⁴ W		1195.63(23)	0.031(14)	0.00051(23)	¹⁸⁶ W		3804.7(4)	0.020(3)	0.00033(5)
¹⁸² W		1262.10(5)	0.0179(24)	0.00030(4)	¹⁸⁶ W		3847.8(4)	0.051(4)	0.00084(7)
¹⁸⁶ W		1269.91(9)	0.031(8)	0.00051(13)	¹⁸³ W		3864.4(4)	0.011(3)	1.8(5)E-4
¹⁸³ W		1275.01(3)	0.032(6)	0.00053(10)	¹⁸⁶ W		3886.4(3)	0.014(3)	2.3(5)E-4
¹⁸³ W		1319.77(5)	0.0134(18)	2.2(3)E-4	¹⁸⁶ W		3901.8(3)	0.024(3)	0.00040(5)
¹⁸⁴ W		1328.3(4)	0.015(3)	2.5(5)E-4	¹⁸⁶ W		3920.2(4)	0.017(3)	0.00028(5)
¹⁸² W		1347.37(13)	0.019(11)	0.00031(18)	¹⁸⁶ W		3964.87(18)	0.034(9)	0.00056(15)
¹⁸⁴ W		1347.6(8)	0.020(9)	0.00033(15)	¹⁸² W		4014.17(5)	0.050(10)	0.00082(16)
¹⁸³ W		1386.22(3)	0.025(3)	0.00041(5)	¹⁸⁶ W		4018.1(5)	0.029(6)	0.00048(10)
¹⁸⁴ W		1408.1(3)	0.0170(22)	0.00028(4)	¹⁸² W		4026.21(10)	0.019(3)	0.00031(5)
¹⁸³ W		1412.03(16)	0.017(5)	0.00028(8)	¹⁸² W		4064.48(9)	0.018(3)	0.00030(5)
¹⁸² W		1424.42(5)	0.030(8)	0.00049(13)	¹⁸⁶ W		4082.8(5)	0.051(11)	0.00084(18)
¹⁸³ W		1430.98(5)	0.0106(15)	1.75(25)E-4	¹⁸⁶ W		4119.24(10)	0.059(4)	0.00097(7)
¹⁸² W		1470.92(5)	0.010(4)	1.6(7)E-4	¹⁸⁶ W		4136.61(17)	0.034(5)	0.00056(8)
¹⁸² W		1504.07(9)	0.0100(11)	1.65(18)E-4	¹⁸⁶ W		4158.13(21)	0.043(5)	0.00071(8)
¹⁸² W		1509.68(13)	0.022(3)	0.00036(5)	¹⁸² W		4162.33(17)	0.0122(15)	2.01(25)E-4
¹⁸² W		1556.18(13)	0.014(3)	2.3(5)E-4	¹⁸⁴ W		4219.2(8)	0.034(16)	0.0006(3)
¹⁸³ W		1569.9(3)	0.013(3)	2.1(5)E-4	¹⁸² W		4246.61(4)	0.043(4)	0.00071(7)
¹⁸³ W		1765.47(9)	0.0105(22)	1.7(4)E-4	¹⁸⁶ W		4249.66(7)	0.115(6)	0.00190(10)
¹⁸³ W		1919.4(4)	0.019(4)	0.00031(7)	¹⁸² W		4304.65(6)	0.020(3)	0.00033(5)
¹⁸³ W		1945.14(15)	0.020(3)	0.00033(5)	¹⁸⁶ W		4331.63(8)	0.040(4)	0.00066(7)
¹⁸³ W		1949.69(7)	0.0097(21)	1.6(4)E-4	¹⁸² W		4367.18(4)	0.026(3)	0.00043(5)

^A Z	E _γ -keV	σ _γ ^Z (E _γ)-barns	k ₀
¹⁸² W	4379.77(5)	0.017(3)	0.00028(5)
¹⁸⁶ W	4384.20(9)	0.057(5)	0.00094(8)
¹⁸⁶ W	4448.10(9)	0.048(3)	0.00079(5)
¹⁸² W	4460.59(9)	0.0124(23)	2.0(4)E-4
¹⁸⁴ W	4469.1(6)	0.022(10)	0.00036(16)
¹⁸⁶ W	4491.51(10)	0.036(10)	0.00059(16)
¹⁸² W	4518.11(5)	0.039(5)	0.00064(8)
¹⁸⁴ W	4535.5(3)	0.08(4)	0.0013(7)
¹⁸⁶ W	4557.49(11)	0.025(5)	0.00041(8)
¹⁸² W	4562.86(14)	0.026(3)	0.00043(5)
¹⁸⁴ W	4573.7(3)	0.104(9)	0.00171(15)
¹⁸⁶ W	4574.94(8)	0.152(10)	0.00251(16)
¹⁸⁶ W	4626.35(7)	0.124(7)	0.00204(12)
¹⁸² W	4634.64(13)	0.015(4)	2.5(7)E-4
¹⁸⁶ W	4650.40(7)	0.052(5)	0.00086(8)
¹⁸⁶ W	4684.40(8)	0.150(7)	0.00247(12)
¹⁸² W	4719.90(5)	0.0189(25)	0.00031(4)
¹⁸⁴ W	4748.7(4)	0.06(3)	0.0010(5)
¹⁸⁴ W	4931.79(25)	0.0119(23)	2.0(4)E-4
¹⁸⁴ W	4980.5(9)	0.017(8)	0.00028(13)
¹⁸⁴ W	4986.2(3)	0.019(9)	0.00031(15)
¹⁸³ W	5015.52(20)	0.0162(20)	0.00027(3)
¹⁸⁴ W	5091.05(25)	0.07(3)	0.0012(5)
¹⁸³ W	5116.55(10)	0.0114(16)	1.9(3)E-4
¹⁸² W	5164.43(3)	0.19(3)	0.0031(5)
¹⁸² W	5256.22(4)	0.0122(12)	2.01(20)E-4
¹⁸⁶ W	5261.68(6)	0.86(4)	0.0142(7)
¹⁸³ W	5285.00(8)	0.0115(14)	1.90(23)E-4
¹⁸⁶ W	5320.72(6)	0.605(21)	0.0100(4)
¹⁸⁶ W	5466.50(6)	0.023(4)	0.00038(7)
¹⁸³ W	5534.37(11)	0.011(4)	1.8(7)E-4
¹⁸⁴ W	5754.53(21)	0.0112(18)	1.8(3)E-4
¹⁸³ W	5796.19(9)	0.023(9)	0.00038(15)
¹⁸³ W	5797.50(9)	0.0161(23)	0.00027(4)
¹⁸³ W	6024.82(7)	0.036(3)	0.00059(5)
¹⁸² W	6144.28(3)	0.174(11)	0.00287(18)
¹⁸³ W	6189.75(7)	0.0264(24)	0.00044(4)
¹⁸² W	6190.78(3)	0.45(4)	0.0074(7)
¹⁸³ W	6289.64(7)	0.0235(19)	0.00039(3)
¹⁸³ W	6408.54(8)	0.043(4)	0.00071(7)
¹⁸³ W	6507.75(7)	0.0098(9)	1.62(15)E-4
¹⁸³ W	7299.78(7)	0.0159(17)	0.00026(3)
¹⁸³ W	7410.99(7)	0.071(4)	0.00117(7)
Rhenium (Z=75), At.Wt.=186.207(1), σ_γ^Z=91.5(10)			
¹⁸⁵ Re	40.3510(20)	0.61(11)	0.0099(18)
¹⁸⁵ Re	56.408(3)	0.106(20)	0.0017(3)
¹⁸⁵ Re	59.0100(20)	5.5(8)	0.090(13)
¹⁸⁵ Re	61.927(4)	0.51(7)	0.0083(11)
¹⁸⁷ Re	63.5820(20)	8.0(14)	0.130(23)
¹⁸⁷ Re	72.047(9)	0.41(5)	0.0067(8)
¹⁸⁵ Re	74.5690(20)	0.64(9)	0.0104(15)
¹⁸⁷ Re	74.8630(20)	1.29(8)	0.0210(13)
¹⁸⁷ Re	85.323(7)	0.109(21)	0.0018(3)
¹⁸⁵ Re	86.83(3)	0.102(24)	0.0017(4)
¹⁸⁵ Re	87.264(3)	0.84(4)	0.0137(7)
¹⁸⁷ Re	87.4800(20)	0.113(19)	0.0018(3)
¹⁸⁷ Re	92.356(3)	0.25(4)	0.0041(7)
¹⁸⁷ Re	92.4640(20)	1.07(6)	0.0174(10)
¹⁸⁵ Re	99.3610(20)	0.230(24)	0.0037(4)
¹⁸⁵ Re	99.698(3)	0.115(24)	0.0019(4)
¹⁸⁵ Re	103.310(4)	0.43(3)	0.0070(5)
¹⁸⁷ Re	105.8620(20)	1.77(8)	0.0288(13)
¹⁸⁵ Re	106.550(4)	0.27(4)	0.0044(7)
¹⁸⁷ Re	107.425(3)	0.352(25)	0.0057(4)
¹⁸⁵ Re	108.336(5)	0.085(19)	0.0014(3)
¹⁸⁵ Re	110.240(4)	0.089(16)	0.0014(3)
¹⁸⁵ Re	111.337(4)	0.58(9)	0.0094(15)
¹⁸⁷ Re	111.590(3)	0.45(5)	0.0073(8)

^A Z	E _γ -keV	σ _γ ^Z (E _γ)-barns	k ₀
¹⁸⁵ Re	111.679(5)	0.68(12)	0.0111(20)
¹⁸⁵ Re	111.814(4)	0.37(7)	0.0060(11)
¹⁸⁷ Re	115.155(3)	0.43(5)	0.0070(8)
¹⁸⁷ Re	115.155(3)	0.28(3)	0.0046(5)
¹⁸⁵ Re	117.94(10)	0.22(4)	0.0036(7)
¹⁸⁵ Re	118.196(4)	0.106(20)	0.0017(3)
¹⁸⁵ Re	122.521(4)	0.74(4)	0.0120(7)
¹⁸⁵ Re	123.507(6)	0.16(3)	0.0026(5)
¹⁸⁵ Re	127.354(3)	0.43(4)	0.0070(7)
¹⁸⁷ Re	128.553(4)	0.105(12)	0.00171(20)
¹⁸⁷ Re	129.973(4)	0.090(15)	0.00146(24)
¹⁸⁷ Re	131.080(4)	0.42(5)	0.0068(8)
¹⁸⁵ Re	137.157(8)d	5.29(3)	0.0861[<0.1%]
¹⁸⁷ Re	138.725(5)	0.19(3)	0.0031(5)
¹⁸⁵ Re	139.417(6)	0.136(19)	0.0022(3)
¹⁸⁵ Re	140.095(5)	0.27(5)	0.0044(8)
¹⁸⁵ Re	141.257(5)	0.19(3)	0.0031(5)
¹⁸⁷ Re	141.760(4)	1.46(8)	0.0238(13)
¹⁸⁷ Re	143.124(4)	0.090(15)	0.00146(24)
¹⁸⁵ Re	143.917(4)	0.55(8)	0.0090(13)
¹⁸⁵ Re	144.152(5)	1.8(3)	0.029(5)
¹⁸⁵ Re	144.157(4)	0.15(15)	0.0024(24)
¹⁸⁷ Re	145.155(5)	0.44(5)	0.0072(8)
¹⁸⁷ Re	145.155(5)	0.28(3)	0.0046(5)
¹⁸⁵ Re	147.415(5)	0.60(9)	0.0098(15)
¹⁸⁵ Re	147.417(6)	0.47(5)	0.0076(8)
¹⁸⁵ Re	148.989(4)	0.29(7)	0.0047(11)
¹⁸⁵ Re	149.520(5)	0.44(5)	0.0072(8)
¹⁸⁷ Re	150.970(4)	0.24(3)	0.0039(5)
¹⁸⁵ Re	151.688(3)	1.15(7)	0.0187(11)
¹⁸⁷ Re	155.041(4)d	7.16(25)	0.117[2.0%]
¹⁸⁷ Re	156.424(4)	0.73(8)	0.0119(13)
¹⁸⁷ Re	158.730(20)	0.15(4)	0.0024(7)
¹⁸⁵ Re	164.466(8)	0.085(21)	0.0014(3)
¹⁸⁷ Re	167.327(3)	1.46(6)	0.0238(10)
¹⁸⁵ Re	167.735(4)	0.20(4)	0.0033(7)
¹⁸⁵ Re	169.434(4)	0.108(23)	0.0018(4)
¹⁸⁵ Re	174.267(3)	0.382(24)	0.0062(4)
¹⁸⁵ Re	176.103(5)	0.18(3)	0.0029(5)
¹⁸⁵ Re	176.552(8)	0.31(3)	0.0050(5)
¹⁸⁷ Re	178.138(5)	0.26(3)	0.0042(5)
¹⁸⁷ Re	178.839(6)	0.20(3)	0.0033(5)
¹⁸⁵ Re	179.448(6)	0.115(21)	0.0019(3)
¹⁸⁷ Re	181.942(5)	0.388(25)	0.0063(4)
¹⁸⁷ Re	188.813(6)	0.98(10)	0.0159(16)
¹⁸⁷ Re	189.33(11)	0.284(24)	0.0046(4)
¹⁸⁵ Re	189.346(8)	0.33(5)	0.0054(8)
¹⁸⁷ Re	193.342(3)	0.43(3)	0.0070(5)
¹⁸⁵ Re	199.337(16)	0.91(4)	0.0148(7)
¹⁸⁷ Re	199.513(5)	1.02(10)	0.0166(16)
¹⁸⁵ Re	200.997(7)	0.098(16)	0.0016(3)
¹⁸⁷ Re	205.342(4)	0.37(8)	0.0060(13)
¹⁸⁷ Re	207.853(4)	4.44(21)	0.072(3)
¹⁸⁷ Re	208.843(7)	0.98(10)	0.0159(16)
¹⁸⁵ Re	209.785(4)	0.14(3)	0.0023(5)
¹⁸⁵ Re	210.698(4)	1.50(10)	0.0244(16)
¹⁸⁷ Re	211.53(3)	0.27(5)	0.0044(8)
¹⁸⁵ Re	214.647(4)	2.53(14)	0.0412(23)
¹⁸⁷ Re	216.033(4)	0.30(7)	0.0049(11)
¹⁸⁷ Re	219.445(7)	0.67(9)	0.0109(15)
¹⁸⁵ Re	219.74(5)	0.081(15)	0.00132(24)
¹⁸⁵ Re	223.016(5)	0.24(6)	0.0039(10)
¹⁸⁷ Re	223.544(5)	0.083(9)	0.00135(15)
¹⁸⁷ Re	227.083(6)	1.78(12)	0.0290(20)
¹⁸⁵ Re	232.100(16)	0.36(7)	0.0059(11)
¹⁸⁵ Re	232.111(9)	0.24(4)	0.0039(7)
¹⁸⁷ Re	236.627(4)	1.45(10)	0.0236(16)
¹⁸⁷ Re	238.450(5)	0.147(24)	0.0024(4)

^A Z	E _γ -keV	σ _γ ^Z (E _γ)-barns	k ₀
¹⁸⁷ Re	246.33(3)	0.091(14)	0.00148(23)
¹⁸⁷Re	251.243(5)	1.80(23)	0.029(4)
¹⁸⁵ Re	251.842(15)	0.58(16)	0.009(3)
¹⁸⁵Re	254.998(4)	1.15(5)	0.0187(8)
¹⁸⁷ Re	256.924(3)	0.66(23)	0.011(4)
¹⁸⁵Re	257.447(9)	0.87(23)	0.014(4)
¹⁸⁵ Re	260.67(7)	0.13(3)	0.0021(5)
¹⁸⁵ Re	261.264(15)	0.67(3)	0.0109(5)
¹⁸⁵ Re	263.367(5)	0.106(24)	0.0017(4)
¹⁸⁷ Re	266.155(20)	0.125(15)	0.00203(24)
¹⁸⁷Re	274.298(5)	0.80(6)	0.0130(10)
¹⁸⁷ Re	275.510(9)	0.51(4)	0.0083(7)
¹⁸⁷ Re	284.590(17)	0.27(5)	0.0044(8)
¹⁸⁵ Re	285.095(23)	0.41(4)	0.0067(7)
¹⁸⁵ Re	287.0(3)	0.12(3)	0.0020(5)
¹⁸⁷Re	290.665(6)	3.5(4)	0.057(7)
¹⁸⁷Re	291.492(8)	0.94(7)	0.0153(11)
¹⁸⁷ Re	299.130(9)	0.151(14)	0.00246(23)
¹⁸⁷ Re	300.210(4)	0.70(5)	0.0114(8)
¹⁸⁵ Re	307.673(16)	0.34(3)	0.0055(5)
¹⁸⁵Re	316.457(9)	2.21(10)	0.0360(16)
¹⁸⁷ Re	317.38(5)	0.083(17)	0.0014(3)
¹⁸⁷ Re	318.37(3)	0.25(3)	0.0041(5)
¹⁸⁵ Re	319.374(9)	0.18(3)	0.0029(5)
¹⁸⁷ Re	352.11(3)	0.116(16)	0.0019(3)
¹⁸⁵ Re	355.646(17)	0.115(16)	0.0019(3)
¹⁸⁵ Re	358.11(10)	0.236(19)	0.0038(3)
¹⁸⁵ Re	360.36(7)	0.449(25)	0.0073(4)
¹⁸⁷ Re	362.712(9)	0.46(3)	0.0075(5)
¹⁸⁵ Re	363.612(8)	0.16(4)	0.0026(7)
¹⁸⁷ Re	376.816(10)	0.083(16)	0.0014(3)
¹⁸⁵ Re	378.384(9)	0.54(3)	0.0088(5)
¹⁸⁵Re	390.854(23)	1.15(5)	0.0187(8)
¹⁸⁷ Re	406.555(9)	0.18(4)	0.0029(7)
¹⁸⁵ Re	407.05(16)	0.102(24)	0.0017(4)
¹⁸⁵ Re	410.74(15)	0.10(3)	0.0016(5)
¹⁸⁵ Re	411.496(10)	0.14(3)	0.0023(5)
¹⁸⁵ Re	413.19(5)	0.16(4)	0.0026(7)
¹⁸⁷ Re	423.525(21)	0.12(3)	0.0020(5)
¹⁸⁷ Re	426.112(9)	0.13(3)	0.0021(5)
¹⁸⁵ Re	439.09(23)	0.14(5)	0.0023(8)
¹⁸⁵ Re	469.79(10)	0.09(3)	0.0015(5)
¹⁸⁵ Re	479.6(3)	0.30(13)	0.0049(21)
¹⁸⁷ Re	493.23(6)	0.10(3)	0.0016(5)
¹⁸⁵ Re	496.57(14)	0.15(4)	0.0024(7)
¹⁸⁷ Re	518.575(9)	0.24(6)	0.0039(10)
¹⁸⁵ Re	550.77(23)	0.15(4)	0.0024(7)
¹⁸⁷ Re	556.81(6)	0.13(4)	0.0021(7)
¹⁸⁵ Re	585.4(3)	0.18(3)	0.0029(5)
¹⁸⁵ Re	608.25(14)	0.25(3)	0.0041(5)
¹⁸⁷ Re	609.04(3)	0.25(3)	0.0041(5)
¹⁸⁵ Re	645.02(14)	0.18(3)	0.0029(5)
¹⁸⁵ Re	680.49(10)	0.34(3)	0.0055(5)
¹⁸⁵ Re	759.94(14)	0.17(5)	0.0028(8)
¹⁸⁵ Re	761.47(23)	0.17(5)	0.0028(8)
¹⁸⁵ Re	796.1(3)	0.31(3)	0.0050(5)
¹⁸⁵ Re	3933.7(8)	0.09(4)	0.0015(7)
¹⁸⁵ Re	4079.0(8)	0.14(3)	0.0023(5)
¹⁸⁵ Re	4099.8(10)	0.13(3)	0.0021(5)
¹⁸⁵ Re	4129.4(8)	0.100(24)	0.0016(4)
¹⁸⁵ Re	4178.1(5)	0.088(22)	0.0014(4)
¹⁸⁵ Re	4455.7(23)	0.11(3)	0.0018(5)
¹⁸⁵ Re	4611.3(5)	0.081(20)	0.0013(3)
¹⁸⁵ Re	4631.7(23)	0.085(23)	0.0014(4)
¹⁸⁵ Re	4663.7(4)	0.24(3)	0.0039(5)
¹⁸⁵ Re	4743.5(8)	0.113(21)	0.0018(3)
¹⁸⁵ Re	4773.7(5)	0.18(3)	0.0029(5)
¹⁸⁵ Re	4860.7(5)	0.37(4)	0.0060(7)

^A Z	E _γ -keV	σ _γ ^Z (E _γ)-barns	k ₀
¹⁸⁵ Re	4871.7(8)	0.11(3)	0.0018(5)
¹⁸⁷ Re	4888.6(3)	0.141(25)	0.0023(4)
¹⁸⁷ Re	4893.4(3)	0.081(17)	0.0013(3)
¹⁸⁷ Re	4916.3(3)	0.102(21)	0.0017(3)
¹⁸⁷ Re	4958.7(5)	0.14(3)	0.0023(5)
¹⁸⁷ Re	4973.1(5)	0.15(3)	0.0024(5)
¹⁸⁷ Re	4987.9(4)	0.17(4)	0.0028(7)
¹⁸⁷ Re	5000.8(4)	0.17(4)	0.0028(7)
¹⁸⁵ Re	5007.0(5)	0.27(4)	0.0044(7)
¹⁸⁷ Re	5012.60(25)	0.18(3)	0.0029(5)
¹⁸⁷ Re	5020.6(4)	0.098(23)	0.0016(4)
¹⁸⁵ Re	5027.9(4)	0.29(5)	0.0047(8)
¹⁸⁵ Re	5048.8(6)	0.096(23)	0.0016(4)
¹⁸⁷ Re	5049.3(3)	0.16(3)	0.0026(5)
¹⁸⁷ Re	5073.28(23)	0.43(5)	0.0070(8)
¹⁸⁷ Re	5080.3(4)	0.098(23)	0.0016(4)
¹⁸⁵ Re	5080.7(8)	0.094(23)	0.0015(4)
¹⁸⁷ Re	5134.8(3)	0.25(6)	0.0041(10)
¹⁸⁵ Re	5137.6(6)	0.39(4)	0.0063(7)
¹⁸⁷ Re	5167.6(3)	0.14(3)	0.0023(5)
¹⁸⁵ Re	5176.3(5)	0.18(3)	0.0029(5)
¹⁸⁷ Re	5224.37(7)	0.081(20)	0.0013(3)
¹⁸⁵ Re	5276.7(5)	0.14(3)	0.0023(5)
¹⁸⁷ Re	5314.86(9)	0.083(20)	0.0014(3)
¹⁸⁷ Re	5348.62(6)	0.20(3)	0.0033(5)
¹⁸⁵ Re	5353.10(13)	0.13(3)	0.0021(5)
¹⁸⁷ Re	5371.95(6)	0.090(19)	0.0015(3)
¹⁸⁵ Re	5493.19(13)	0.114(18)	0.0019(3)
¹⁸⁵ Re	5601.53(13)	0.109(18)	0.0018(3)
¹⁸⁷ Re	5614.74(6)	0.092(17)	0.0015(3)
¹⁸⁵ Re	5644.95(15)	0.088(16)	0.0014(3)
¹⁸⁷ Re	5688.91(6)	0.120(17)	0.0020(3)
¹⁸⁷ Re	5702.21(6)	0.100(16)	0.0016(3)
¹⁸⁵ Re	5708.74(13)	0.115(17)	0.0019(3)
¹⁸⁵ Re	5709.49(20)	0.098(24)	0.0016(4)
¹⁸⁷ Re	5715.61(6)	0.086(16)	0.0014(3)
¹⁸⁵ Re	5856.86(13)	0.140(15)	0.00228(24)
¹⁸⁷ Re	5871.65(6)	0.299(23)	0.0049(4)
¹⁸⁵ Re	5910.44(13)	0.60(4)	0.0098(7)
¹⁸⁵ Re	6005.30(13)	0.081(11)	0.00132(18)
¹⁸⁵ Re	6032.96(13)	0.090(12)	0.00146(20)
¹⁸⁵ Re	6079.87(13)	0.155(13)	0.00252(21)
¹⁸⁵ Re	6120.22(13)	0.182(16)	0.0030(3)
Osmium (Z=76), At. Wt.=190.23(3), σ_γ^Z=16.0(11)			
¹⁸⁴ Os	37.18(13)	0.034(6)	0.00054(10)
¹⁹⁰ Os	57.480(10)	0.10(3)	0.0016(5)
¹⁹⁰ Os	57.74(6)	0.081(6)	0.00129(10)
¹⁸⁸ Os	59.079(16)	0.046(5)	0.00073(8)
¹⁹⁰ Os	67.24(20)	0.021(4)	0.00033(6)
¹⁹² Os	73.43(4)	0.174(8)	0.00277(13)
¹⁸⁴ Os	90.95(15)	0.030(15)	0.00048(24)
¹⁹² Os	131.26(5)	0.0291(17)	0.00046(3)
¹⁹⁰ Os	138.070(10)	0.0239(16)	0.000381(25)
¹⁹² Os	138.92(3)d	0.0467(22)	0.00074[1.1%]
¹⁸⁷Os	155.10(4)	1.19(3)	0.0190(5)
¹⁸⁴ Os	158.40(10)	0.025(7)	0.00040(11)
¹⁹⁰ Os	172.50(10)	0.025(4)	0.00040(6)
¹⁹⁰ Os	175.80(4)	0.189(8)	0.00301(13)
¹⁸⁶ Os	177.42(20)	0.021(4)	0.00033(6)
¹⁸⁹ Os	182.02(10)	0.027(7)	0.00043(11)
¹⁹⁰ Os	182.30(10)	0.043(5)	0.00069(8)
¹⁸⁹Os	186.7180(20)	2.08(5)	0.0331(8)
¹⁹⁰ Os	194.25(8)	0.028(3)	0.00045(5)
¹⁸⁹ Os	198.084(21)	0.056(7)	0.00089(11)
¹⁹² Os	204.42(4)	0.081(4)	0.00129(6)
¹⁸⁴ Os	222.38(14)	0.021(7)	0.00033(11)
¹⁸⁹ Os	223.810(7)	0.052(4)	0.00083(6)
¹⁹⁰ Os	229.93(4)	0.072(4)	0.00115(6)

^A Z	E _γ -keV	σ _γ ^Z (E _γ)-barns	k ₀	^A Z	E _γ -keV	σ _γ ^Z (E _γ)-barns	k ₀
¹⁹⁰ Os	235.24(3)	0.184(6)	0.00293(10)	¹⁸⁴ Os	538.8(4)	0.023(7)	0.00037(11)
¹⁹⁰ Os	239.890(10)	0.080(4)	0.00127(6)	¹⁸⁴ Os	539.40(24)	0.022(4)	0.00035(6)
¹⁹² Os	242.41(4)	0.069(4)	0.00110(6)	¹⁹⁰ Os	545.29(13)	0.031(4)	0.00049(6)
¹⁹² Os	254.39(5)	0.0368(22)	0.00059(4)	¹⁸⁸ Os	550.17(5)	0.021(4)	0.00033(6)
¹⁹² Os	265.71(3)	0.101(3)	0.00161(5)	¹⁸⁹Os	557.978(5)	0.84(3)	0.0134(5)
¹⁸⁸Os	272.82(4)	0.242(6)	0.00386(10)	¹⁸⁹Os	569.344(20)	0.694(25)	0.0111(4)
¹⁹⁰ Os	275.34(3)	0.173(5)	0.00276(8)	¹⁸⁴ Os	589.87(19)	0.034(5)	0.00054(8)
¹⁹⁰ Os	291.650(10)	0.047(3)	0.00075(5)	¹⁸⁹ Os	605.26(3)	0.113(4)	0.00180(6)
¹⁹⁰ Os	295.030(10)	0.030(5)	0.00048(8)	¹⁸⁷ Os	623.92(11)	0.036(4)	0.00057(6)
¹⁹² Os	295.41(5)	0.055(4)	0.00088(6)	¹⁸⁹ Os	630.985(23)	0.023(4)	0.00037(6)
¹⁹⁰ Os	304.71(6)	0.073(4)	0.00116(6)	¹⁸⁷Os	633.14(4)	0.585(16)	0.00932(25)
¹⁹⁰ Os	305.020(10)	0.022(4)	0.00035(6)	¹⁸⁷Os	635.02(5)	0.405(12)	0.00645(19)
¹⁹² Os	307.080(10)	0.026(3)	0.00041(5)	¹⁹⁰ Os	636.7(3)	0.028(6)	0.00045(10)
¹⁹⁰ Os	307.21(10)	0.026(3)	0.00041(5)	¹⁹² Os	655.61(13)	0.025(3)	0.00040(5)
¹⁹⁰ Os	314.72(10)	0.039(3)	0.00062(5)	¹⁹⁰ Os	664.18(9)	0.036(4)	0.00057(6)
¹⁹⁰ Os	316.45(11)	0.030(4)	0.00048(6)	¹⁸⁷ Os	672.64(11)	0.045(4)	0.00072(6)
¹⁸⁷Os	322.98(6)	0.242(9)	0.00386(14)	¹⁸⁹ Os	725.11(5)	0.081(5)	0.00129(8)
¹⁹⁰ Os	332.690(10)	0.055(5)	0.00088(8)	¹⁸⁹ Os	768.653(15)	0.037(3)	0.00059(5)
¹⁹⁰ Os	339.61(5)	0.055(3)	0.00088(5)	¹⁹⁰ Os	768.67(10)	0.046(5)	0.00073(8)
¹⁸⁸ Os	343.473(20)	0.051(16)	0.00081(25)	¹⁹² Os	786.64(15)	0.033(4)	0.00053(6)
¹⁹⁰ Os	343.61(6)	0.046(3)	0.00073(5)	¹⁸⁷ Os	810.60(11)	0.035(3)	0.00056(5)
¹⁹⁰ Os	345.92(10)	0.034(4)	0.00054(6)	¹⁸⁷ Os	824.43(11)	0.052(4)	0.00083(6)
¹⁸⁸ Os	346.871(25)	0.025(8)	0.00040(13)	¹⁸⁷ Os	826.79(10)	0.029(3)	0.00046(5)
¹⁸⁷ Os	347.24(17)	0.023(4)	0.00037(6)	¹⁸⁹ Os	829.07(3)	0.056(6)	0.00089(10)
¹⁹⁰ Os	349.25(6)	0.051(4)	0.00081(6)	¹⁸⁷ Os	829.62(12)	0.109(16)	0.00174(25)
¹⁹⁰ Os	352.56(9)	0.041(5)	0.00065(8)	¹⁸⁷ Os	844.68(14)	0.024(4)	0.00038(6)
¹⁸⁹ Os	353.85(5)	0.0213(24)	0.00034(4)	¹⁸⁹ Os	928.06(5)	0.085(5)	0.00135(8)
¹⁹⁰ Os	355.80(10)	0.025(4)	0.00040(6)	¹⁸⁷ Os	931.31(8)	0.073(5)	0.00116(8)
¹⁸⁹ Os	358.71(5)	0.033(4)	0.00053(6)	¹⁹² Os	951.14(5)	0.089(4)	0.00142(6)
¹⁹⁰ Os	359.01(7)	0.047(4)	0.00075(6)	¹⁸⁷ Os	987.33(13)	0.031(4)	0.00049(6)
¹⁸⁹Os	361.137(6)	0.466(15)	0.00742(24)	¹⁸⁹ Os	987.41(7)	0.071(6)	0.00113(10)
¹⁹⁰ Os	362.36(15)	0.040(9)	0.00064(14)	¹⁸⁹ Os	1011.09(10)	0.031(4)	0.00049(6)
¹⁹⁰ Os	365.04(12)	0.035(5)	0.00056(8)	¹⁸⁷ Os	1017.84(20)	0.043(4)	0.00069(6)
¹⁹⁰ Os	366.33(5)	0.097(6)	0.00155(10)	¹⁸⁹ Os	1103.08(8)	0.047(5)	0.00075(8)
¹⁸⁹Os	371.261(5)	0.574(14)	0.00914(22)	¹⁸⁹ Os	1114.77(5)	0.060(5)	0.00096(8)
¹⁹⁰ Os	397.270(10)	0.038(6)	0.00061(10)	¹⁸⁹ Os	1117.79(8)	0.033(5)	0.00053(8)
¹⁸⁹ Os	397.394(14)	0.115(5)	0.00183(8)	¹⁸⁷ Os	1149.77(8)	0.079(6)	0.00126(10)
¹⁸⁶ Os	400.84(22)	0.022(6)	0.00035(10)	¹⁸⁹ Os	1154.47(16)	0.029(9)	0.00046(14)
¹⁹⁰ Os	403.25(5)	0.065(4)	0.00104(6)	¹⁹⁰ Os	1155.76(15)	0.042(5)	0.00067(8)
¹⁸⁹ Os	407.175(22)	0.060(7)	0.00096(11)	¹⁸⁷ Os	1174.82(20)	0.038(7)	0.00061(11)
¹⁸⁹ Os	407.517(15)	0.134(5)	0.00213(8)	¹⁸⁹ Os	1174.95(9)	0.080(6)	0.00127(10)
¹⁸⁸ Os	410.602(21)	0.028(9)	0.00045(14)	¹⁸⁷ Os	1191.92(17)	0.034(5)	0.00054(8)
¹⁹⁰ Os	413.23(4)	0.103(5)	0.00164(8)	¹⁸⁹ Os	1195.95(11)	0.077(6)	0.00123(10)
¹⁹⁰ Os	423.76(7)	0.044(4)	0.00070(6)	¹⁸⁷ Os	1209.62(13)	0.063(6)	0.00100(10)
¹⁸⁶ Os	427.07(17)	0.022(4)	0.00035(6)	¹⁸⁹ Os	1213.91(13)	0.031(6)	0.00049(10)
¹⁸⁴ Os	431.45(20)	0.09(3)	0.0014(5)	¹⁸⁹ Os	1249.14(6)	0.035(5)	0.00056(8)
¹⁸⁹ Os	431.68(3)	0.036(4)	0.00057(6)	¹⁸⁹ Os	1254.76(20)	0.041(5)	0.00065(8)
¹⁹⁰ Os	434.16(12)	0.032(4)	0.00051(6)	¹⁸⁹ Os	1265.85(12)	0.029(5)	0.00046(8)
¹⁹⁰ Os	442.18(12)	0.022(4)	0.00035(6)	¹⁸⁹ Os	1301.17(8)	0.035(5)	0.00056(8)
¹⁸⁹ Os	447.79(7)	0.0213(19)	0.00034(3)	¹⁸⁷ Os	1307.9(3)	0.025(3)	0.00040(5)
¹⁹⁰ Os	453.69(24)	0.022(5)	0.00035(8)	¹⁸⁹ Os	1311.29(8)	0.031(3)	0.00049(5)
¹⁸⁸ Os	454.794(21)	0.028(9)	0.00045(14)	¹⁸⁷ Os	1322.72(14)	0.037(4)	0.00059(6)
¹⁹² Os	455.47(24)	0.025(5)	0.00040(8)	¹⁸⁷ Os	1332.35(20)	0.05(3)	0.0008(5)
¹⁸⁸ Os	469.682(21)	0.040(5)	0.00064(8)	¹⁸⁷ Os	1332.53(25)	0.040(4)	0.00064(6)
¹⁹² Os	471.60(25)	0.021(5)	0.00033(8)	¹⁸⁹ Os	1382.66(11)	0.026(3)	0.00041(5)
¹⁹⁰ Os	475.33(16)	0.032(6)	0.00051(10)	¹⁸⁹ Os	1383.59(23)	0.026(4)	0.00041(6)
¹⁸⁷Os	478.04(4)	0.523(14)	0.00833(22)	¹⁸⁹ Os	1384.7(4)	0.023(5)	0.00037(8)
¹⁹⁰ Os	480.85(12)	0.043(7)	0.00069(11)	¹⁸⁹ Os	1412.00(13)	0.0272(22)	0.00043(4)
¹⁹⁰ Os	485.87(20)	0.027(7)	0.00043(11)	¹⁸⁹ Os	1429.31(11)	0.028(5)	0.00045(8)
¹⁸⁷ Os	487.62(12)	0.044(7)	0.00070(11)	¹⁸⁷ Os	1435.74(14)	0.055(10)	0.00088(16)
¹⁹⁰ Os	495.68(9)	0.035(7)	0.00056(11)	¹⁸⁹ Os	1436.94(14)	0.045(6)	0.00072(10)
¹⁹⁰ Os	499.77(8)	0.054(5)	0.00086(8)	¹⁸⁷ Os	1452.88(19)	0.024(4)	0.00038(6)
¹⁸⁸ Os	505.861(20)	0.021(4)	0.00033(6)	¹⁸⁷ Os	1457.56(11)	0.059(5)	0.00094(8)
¹⁸⁴ Os	512.84(5)	0.084(8)	0.00134(13)	¹⁸⁷ Os	1465.36(13)	0.048(5)	0.00076(8)
¹⁸⁷ Os	514.76(9)	0.038(4)	0.00061(6)	¹⁸⁹ Os	1489.05(8)	0.031(6)	0.00049(10)
¹⁸⁴ Os	521.9(3)	0.024(5)	0.00038(8)	¹⁸⁹ Os	1512.11(19)	0.039(7)	0.00062(11)
¹⁹⁰Os	527.60(3)	0.300(10)	0.00478(16)	¹⁸⁹ Os	1546.20(9)	0.049(7)	0.00078(11)
¹⁹⁰ Os	537.75(4)	0.121(6)	0.00193(10)	¹⁸⁷ Os	1574.48(14)	0.031(6)	0.00049(10)

^A Z	E _γ -keV	σ _γ ^Z (E _γ)-barns	k ₀	^A Z	E _γ -keV	σ _γ ^Z (E _γ)-barns	k ₀
¹⁸⁹ Os	1616.03(11)	0.033(6)	0.00053(10)	¹⁸⁷ Os	5920.60(14)	0.044(6)	0.00070(10)
¹⁸⁹ Os	1672.42(8)	0.035(6)	0.00056(10)	¹⁸⁹ Os	5933.06(13)	0.096(8)	0.00153(13)
¹⁸⁹ Os	1680.73(16)	0.053(6)	0.00084(10)	¹⁸⁴ Os	6155.8(3)	0.044(6)	0.00070(10)
¹⁸⁹ Os	1732.0(3)	0.024(5)	0.00038(8)	¹⁸⁹ Os	6246.81(12)	0.026(3)	0.00041(5)
¹⁸⁹ Os	1770.5(5)	0.026(3)	0.00041(5)	¹⁸⁹ Os	6409.53(14)	0.026(3)	0.00041(5)
¹⁸⁷ Os	1802.35(13)	0.035(5)	0.00056(8)	¹⁸⁴ Os	6587.21(25)	0.093(13)	0.00148(21)
¹⁸⁹ Os	1883.37(19)	0.027(9)	0.00043(14)	¹⁸⁹ Os	7234.19(11)	0.044(4)	0.00070(6)
¹⁸⁷ Os	1957.46(13)	0.027(6)	0.00043(10)	¹⁸⁹ Os	7792.14(11)	0.034(3)	0.00054(5)
¹⁸⁷ Os	2011.29(20)	0.021(5)	0.00033(8)	¹⁸⁷ Os	7834.30(8)	0.0247(23)	0.00039(4)
¹⁸⁷ Os	2022.95(14)	0.053(6)	0.00084(10)	¹⁸⁷ Os	7989.40(7)	0.0208(14)	0.000331(22)
¹⁸⁷ Os	2098.77(22)	0.0208(24)	0.00033(4)	Iridium (Z=77), At.Wt.=192.217(3), σ_γ^Z=425(5)			
¹⁸⁷ Os	2131.44(14)	0.052(6)	0.00083(10)	¹⁹¹ Ir	23.9670(20)	0.170(14)	0.00268(22)
¹⁸⁷ Os	2193.17(24)	0.031(6)	0.00049(10)	¹⁹¹ Ir	26.2260(20)	0.132(9)	0.00208(14)
¹⁸⁷ Os	2214.6(3)	0.039(7)	0.00062(11)	¹⁹³ Ir	39.2160(10)	0.17(11)	0.0027(17)
¹⁸⁷ Os	2261.21(14)	0.077(7)	0.00123(11)	¹⁹³ Ir	43.1190(10)	0.9(3)	0.014(5)
¹⁸⁷ Os	2286.54(14)	0.052(8)	0.00083(13)	¹⁹¹Ir	48.0570(10)	5.7(4)	0.090(6)
¹⁸⁷ Os	2306.04(21)	0.0215(18)	0.00034(3)	¹⁹¹ Ir	49.379(4)	0.122(10)	0.00192(16)
¹⁸⁷ Os	2505.13(24)	0.040(5)	0.00064(8)	¹⁹¹ Ir	49.9560(20)	0.115(9)	0.00181(14)
¹⁸⁷ Os	2606.38(21)	0.023(5)	0.00037(8)	¹⁹¹ Ir	50.782(8)	0.132(11)	0.00208(17)
¹⁸⁷ Os	2623.10(21)	0.023(5)	0.00037(8)	¹⁹¹ Ir	54.3210(20)	0.54(20)	0.009(3)
¹⁸⁷ Os	2817.11(25)	0.026(5)	0.00041(8)	¹⁹³ Ir	54.4030(10)	0.12(8)	0.0019(13)
¹⁸⁷ Os	3021.7(3)	0.026(3)	0.00041(5)	¹⁹¹Ir	58.8440(10)	5.3(3)	0.084(5)
¹⁸⁷ Os	3069.9(3)	0.028(5)	0.00045(8)	¹⁹¹Ir	66.822(8)	1.31(13)	0.0207(20)
¹⁸⁷ Os	3110.00(18)	0.0273(19)	0.00043(3)	¹⁹¹ Ir	69.252(3)	0.25(7)	0.0039(11)
¹⁸⁷ Os	3176.9(3)	0.025(5)	0.00040(8)	¹⁹³ Ir	69.4740(20)	0.19(14)	0.0030(22)
¹⁹² Os	3980.58(25)	0.035(4)	0.00056(6)	¹⁹¹ Ir	72.0240(20)	0.6(3)	0.009(5)
¹⁸⁸ Os	4222.8(5)	0.052(6)	0.00083(10)	¹⁹¹ Ir	72.328(4)	0.28(9)	0.0044(14)
¹⁹² Os	4530.27(22)	0.090(8)	0.00143(13)	¹⁹¹ Ir	77.369(3)	0.38(11)	0.0060(17)
¹⁹⁰ Os	4556.2(3)	0.035(7)	0.00056(11)	¹⁹¹Ir	77.9470(10)	4.8(4)	0.076(6)
¹⁹⁰ Os	4666.6(3)	0.024(6)	0.00038(10)	¹⁹³ Ir	82.3350(10)	0.5(3)	0.008(5)
¹⁹² Os	4694.4(3)	0.025(5)	0.00040(8)	¹⁹¹ Ir	83.965(8)	0.18(9)	0.0028(14)
¹⁸⁷ Os	4749.98(22)	0.042(6)	0.00067(10)	¹⁹¹Ir	84.2740(20)	7.7(4)	0.121(6)
¹⁸⁷ Os	4812.6(3)	0.049(7)	0.00078(11)	¹⁹³ Ir	84.2840(10)	1.0(6)	0.016(10)
¹⁸⁷ Os	4919.6(3)	0.037(3)	0.00059(5)	¹⁹¹ Ir	86.8340(20)	0.65(13)	0.0102(20)
¹⁸⁷ Os	4959.35(25)	0.021(5)	0.00033(8)	¹⁹¹Ir	88.7340(10)	3.67(24)	0.058(4)
¹⁹⁰ Os	5010.7(3)	0.029(6)	0.00046(10)	¹⁹¹Ir	90.7030(20)	1.25(15)	0.0197(24)
¹⁹⁰ Os	5036.9(3)	0.041(6)	0.00065(10)	¹⁹¹ Ir	90.857(3)	0.20(4)	0.0032(6)
¹⁸⁷ Os	5096.77(22)	0.037(7)	0.00059(11)	¹⁹³ Ir	93.1630(10)	0.3(3)	0.005(5)
¹⁹⁰Os	5146.63(14)	0.409(20)	0.0065(3)	¹⁹¹ Ir	95.056(6)	0.24(5)	0.0038(8)
¹⁸⁷ Os	5172.38(25)	0.031(6)	0.00049(10)	¹⁹¹ Ir	95.470(4)	0.9(3)	0.014(5)
¹⁸⁷ Os	5223.66(21)	0.0215(21)	0.00034(3)	¹⁹³ Ir	95.5690(10)	0.8(5)	0.013(8)
¹⁸⁷ Os	5250.4(7)	0.029(6)	0.00046(10)	¹⁹¹ Ir	97.347(3)	0.25(5)	0.0039(8)
¹⁹² Os	5277.11(22)	0.116(15)	0.00185(24)	¹⁹¹ Ir	97.348(4)	0.36(14)	0.0057(22)
¹⁸⁹ Os	5315.8(3)	0.024(7)	0.00038(11)	¹⁹¹ Ir	98.524(4)	0.32(5)	0.0050(8)
¹⁹⁰ Os	5341.4(3)	0.074(12)	0.00118(19)	¹⁹¹ Ir	99.603(6)	0.24(13)	0.0038(20)
¹⁸⁸ Os	5364.5(4)	0.028(7)	0.00045(11)	¹⁹³ Ir	100.4030(20)	0.13(8)	0.0020(13)
¹⁸⁷ Os	5366.38(21)	0.028(7)	0.00045(11)	¹⁹¹ Ir	104.043(9)	0.13(4)	0.0020(6)
¹⁸⁸ Os	5371.8(4)	0.023(7)	0.00037(11)	¹⁹¹ Ir	105.159(3)	0.14(6)	0.0022(10)
¹⁸⁸ Os	5416.0(4)	0.053(20)	0.0008(3)	¹⁹¹ Ir	107.015(3)	0.20(7)	0.0032(11)
¹⁸⁸ Os	5483.1(4)	0.049(8)	0.00078(13)	¹⁹¹ Ir	107.132(4)	0.23(6)	0.0036(10)
¹⁸⁷ Os	5484.35(24)	0.049(8)	0.00078(13)	¹⁹¹Ir	108.0300(20)	2.62(12)	0.0413(19)
¹⁸⁹ Os	5502.8(6)	0.021(6)	0.00033(10)	¹⁹¹ Ir	108.658(4)	0.11(3)	0.0017(5)
¹⁸⁷ Os	5528.34(22)	0.038(7)	0.00061(11)	¹⁹¹ Ir	110.352(3)	0.53(7)	0.0084(11)
¹⁸⁹ Os	5529.1(7)	0.045(8)	0.00072(13)	¹⁹¹ Ir	111.025(3)	0.99(11)	0.0156(17)
¹⁸⁷ Os	5573.17(15)	0.052(6)	0.00083(10)	¹⁹³Ir	112.2310(10)	1.7(4)	0.027(6)
¹⁹² Os	5583.70(20)	0.076(7)	0.00121(11)	¹⁹³ Ir	115.4730(10)	0.5(3)	0.008(5)
¹⁸⁹ Os	5599.6(7)	0.024(5)	0.00038(8)	¹⁹³ Ir	117.8790(10)	0.4(3)	0.006(5)
¹⁸⁷ Os	5641.20(23)	0.023(4)	0.00037(6)	¹⁹¹ Ir	118.268(3)	0.15(3)	0.0024(5)
¹⁹⁰ Os	5674.5(4)	0.038(7)	0.00061(11)	¹⁹¹ Ir	118.7820(10)	0.56(7)	0.0088(11)
¹⁸⁹ Os	5680.3(3)	0.045(9)	0.00072(14)	¹⁹¹ Ir	121.139(3)	0.17(7)	0.0027(11)
¹⁹⁰ Os	5683.87(21)	0.167(13)	0.00266(21)	¹⁹¹ Ir	122.596(3)	0.41(7)	0.0065(11)
¹⁸⁷ Os	5702.93(15)	0.050(8)	0.00080(13)	¹⁹³ Ir	123.8450(10)	1.0(6)	0.016(10)
¹⁸⁶ Os	5703.4(7)	0.050(8)	0.00080(13)	¹⁹¹Ir	126.958(3)	1.86(10)	0.0293(16)
¹⁸⁹ Os	5749.8(10)	0.026(6)	0.00041(10)	¹⁹³ Ir	132.8790(20)	0.18(10)	0.0028(16)
¹⁸⁹ Os	5782.7(3)	0.024(6)	0.00038(10)	¹⁹¹ Ir	133.925(6)	0.19(5)	0.0030(8)
¹⁸⁹ Os	5873.5(3)	0.030(6)	0.00048(10)	¹⁹³ Ir	136.1000(20)	0.17(11)	0.0027(17)
¹⁸⁹ Os	5881.67(19)	0.035(6)	0.00056(10)	¹⁹¹Ir	136.1250(10)	6.5(9)	0.102(14)
¹⁸⁸ Os	5885.7(4)	0.041(7)	0.00065(11)	¹⁹¹Ir	136.213(3)	4.0(5)	0.063(8)

^A Z	E _γ -keV	σ _γ ^Z (E _γ)-barns	k ₀	^A Z	E _γ -keV	σ _γ ^Z (E _γ)-barns	k ₀
¹⁹¹ Ir	136.7910(10)	2.20(21)	0.035(3)	¹⁹³ Ir	224.0830(20)	0.18(11)	0.0028(17)
¹⁹¹ Ir	138.2480(20)	0.53(7)	0.0084(11)	¹⁹³ Ir	225.4180(20)	0.12(7)	0.0019(11)
¹⁹³ Ir	138.6880(10)	0.8(5)	0.013(8)	¹⁹¹Ir	226.2980(20)	4.0(4)	0.063(6)
¹⁹¹ Ir	139.736(5)	0.27(4)	0.0043(6)	¹⁹³ Ir	226.6390(10)	0.20(12)	0.0032(19)
¹⁹¹ Ir	140.257(6)	0.32(5)	0.0050(8)	¹⁹¹ Ir	226.722(5)	0.19(4)	0.0030(6)
¹⁹¹ Ir	140.814(6)	0.16(5)	0.0025(8)	¹⁹³ Ir	228.0650(20)	0.12(8)	0.0019(13)
¹⁹³ Ir	143.5940(10)	0.6(3)	0.009(5)	¹⁹¹ Ir	229.771(11)	0.48(11)	0.0076(17)
¹⁹¹ Ir	144.849(4)	0.57(9)	0.0090(14)	¹⁹¹ Ir	231.683(3)	0.95(13)	0.0150(20)
¹⁹¹Ir	144.903(5)	3.1(4)	0.049(6)	¹⁹¹ Ir	232.907(4)	0.20(4)	0.0032(6)
¹⁹³ Ir	145.2220(10)	0.11(7)	0.0017(11)	¹⁹³ Ir	234.8190(20)	0.44(13)	0.0069(20)
¹⁹¹ Ir	148.821(3)	1.08(12)	0.0170(19)	¹⁹¹ Ir	241.867(7)	0.65(13)	0.0102(20)
¹⁹¹ Ir	148.822(3)	1.08(12)	0.0170(19)	¹⁹³ Ir	245.1090(20)	0.14(9)	0.0022(14)
¹⁹³Ir	148.9340(10)	1.4(9)	0.022(14)	¹⁹³ Ir	245.4920(20)	0.33(22)	0.005(4)
¹⁹¹ Ir	151.450(5)	0.26(5)	0.0041(8)	¹⁹¹ Ir	246.169(3)	0.15(4)	0.0024(6)
¹⁹¹Ir	151.5640(20)	2.89(20)	0.046(3)	¹⁹¹ Ir	246.800(4)	0.32(9)	0.0050(14)
¹⁹³ Ir	152.4080(10)	0.37(23)	0.006(4)	¹⁹³ Ir	248.6000(20)	0.24(15)	0.0038(24)
¹⁹³ Ir	152.942(11)	0.55(13)	0.0087(20)	¹⁹³ Ir	252.2750(10)	0.11(7)	0.0017(11)
¹⁹³ Ir	153.0550(10)	0.5(3)	0.008(5)	¹⁹¹ Ir	252.499(12)	0.5(3)	0.008(5)
¹⁹¹ Ir	156.0870(20)	1.02(12)	0.0161(19)	¹⁹¹ Ir	254.277(4)	1.08(11)	0.0170(17)
¹⁹¹Ir	156.654(3)	2.76(12)	0.0435(19)	¹⁹³ Ir	255.3130(20)	0.36(13)	0.0057(20)
¹⁹¹ Ir	158.180(4)	0.15(4)	0.0024(6)	¹⁹¹ Ir	258.320(5)	0.24(5)	0.0038(8)
¹⁹³ Ir	160.8250(20)	0.34(11)	0.0054(17)	¹⁹¹Ir	261.953(6)	2.02(23)	0.032(4)
¹⁹³ Ir	160.9980(10)	0.4(3)	0.006(5)	¹⁹¹Ir	262.03(10)	3.05(18)	0.048(3)
¹⁹³ Ir	162.7740(20)	0.24(15)	0.0038(24)	¹⁹³ Ir	262.7290(10)	0.14(8)	0.0022(13)
¹⁹¹ Ir	162.850(6)	0.14(3)	0.0022(5)	¹⁹¹ Ir	263.573(6)	0.86(10)	0.0136(16)
¹⁹³ Ir	165.3800(20)	0.27(23)	0.004(4)	¹⁹¹ Ir	264.008(7)	0.57(7)	0.0090(11)
¹⁹³ Ir	165.4500(20)	0.35(22)	0.006(4)	¹⁹³ Ir	264.7680(20)	0.8(5)	0.013(8)
¹⁹¹ Ir	166.089(5)	0.89(10)	0.0140(16)	¹⁹¹ Ir	267.415(4)	0.93(21)	0.015(3)
¹⁹¹ Ir	166.435(4)	0.24(4)	0.0038(6)	¹⁹³ Ir	271.6810(20)	0.6(4)	0.009(6)
¹⁹¹Ir	169.196(3)	3.05(13)	0.0481(20)	¹⁹¹ Ir	273.235(8)	0.49(8)	0.0077(13)
¹⁹¹ Ir	169.542(5)	0.52(7)	0.0082(11)	¹⁹¹ Ir	273.236(7)	0.72(17)	0.011(3)
¹⁹¹ Ir	169.542(4)	0.52(7)	0.0082(11)	¹⁹¹ Ir	273.568(5)	0.18(6)	0.0028(10)
¹⁹³ Ir	169.5660(10)	0.24(15)	0.0038(24)	¹⁹¹ Ir	275.0380(20)	0.74(16)	0.0117(25)
¹⁹³ Ir	169.8760(10)	0.15(9)	0.0024(14)	¹⁹³ Ir	275.2990(10)	0.6(4)	0.009(6)
¹⁹¹ Ir	172.839(3)	0.53(24)	0.008(4)	¹⁹¹ Ir	276.787(4)	0.55(12)	0.0087(19)
¹⁹¹ Ir	174.139(8)	0.21(4)	0.0033(6)	¹⁹¹ Ir	278.193(8)	0.42(5)	0.0066(8)
¹⁹³ Ir	176.6510(20)	0.15(10)	0.0024(16)	¹⁹³Ir	278.5040(10)	1.8(11)	0.028(17)
¹⁹¹ Ir	176.812(3)	0.6(4)	0.009(6)	¹⁹¹Ir	284.074(6)	1.95(15)	0.0307(24)
¹⁹¹ Ir	177.919(7)	0.28(6)	0.0044(10)	¹⁹¹ Ir	284.947(3)	0.52(7)	0.0082(11)
¹⁹¹Ir	179.0380(20)	2.1(5)	0.033(8)	¹⁹³ Ir	288.4310(20)	0.12(7)	0.0019(11)
¹⁹¹ Ir	183.626(3)	1.0(4)	0.016(6)	¹⁹¹ Ir	292.374(4)	0.42(12)	0.0066(19)
¹⁹³ Ir	184.6870(20)	0.92(22)	0.015(4)	¹⁹³Ir	293.541(14)d	1.76(6)	0.0277[1.8%]
¹⁹¹ Ir	187.521(3)	0.43(5)	0.0068(8)	¹⁹³ Ir	294.5300(20)	0.41(25)	0.006(4)
¹⁹¹ Ir	188.204(3)	0.52(23)	0.008(4)	¹⁹¹ Ir	296.257(8)	0.65(17)	0.010(3)
¹⁹¹ Ir	189.100(7)	0.47(18)	0.007(3)	¹⁹¹ Ir	299.476(8)	0.13(4)	0.0020(6)
¹⁹¹ Ir	193.718(3)	0.83(11)	0.0131(17)	¹⁹¹Ir	302.905(8)	1.20(11)	0.0189(17)
¹⁹³ Ir	193.9300(20)	0.21(13)	0.0033(20)	¹⁹¹ Ir	305.448(4)	0.45(10)	0.0071(16)
¹⁹¹ Ir	195.433(4)	0.27(7)	0.0043(11)	¹⁹³ Ir	308.9740(10)	0.6(4)	0.009(6)
¹⁹³ Ir	195.5270(10)	0.21(13)	0.0033(20)	¹⁹¹ Ir	310.010(6)	0.26(8)	0.0041(13)
¹⁹¹ Ir	197.061(7)	0.73(19)	0.012(3)	¹⁹¹ Ir	310.08(10)	0.61(10)	0.0096(16)
¹⁹³ Ir	198.8370(20)	0.15(9)	0.0024(14)	¹⁹³ Ir	311.4960(10)	0.16(10)	0.0025(16)
¹⁹¹ Ir	199.174(7)	1.07(18)	0.017(3)	¹⁹¹ Ir	311.630(6)	0.23(6)	0.0036(10)
¹⁹¹ Ir	199.418(5)	0.14(4)	0.0022(6)	¹⁹³ Ir	314.0520(10)	0.26(17)	0.004(3)
¹⁹¹ Ir	201.111(5)	0.21(6)	0.0033(10)	¹⁹¹Ir	316.061(7)	2.4(4)	0.038(6)
¹⁹¹ Ir	203.015(3)	0.27(4)	0.0043(6)	¹⁹¹ Ir	322.510(5)	0.51(11)	0.0080(17)
¹⁹¹Ir	206.220(4)	3.70(18)	0.058(3)	¹⁹³Ir	328.448(14)d	9.1(3)	0.143[1.8%]
¹⁹¹ Ir	207.301(5)	0.50(6)	0.0079(10)	¹⁹¹Ir	333.864(6)	1.53(10)	0.0241(16)
¹⁹¹ Ir	208.440(6)	0.70(9)	0.0110(14)	¹⁹³ Ir	337.5240(20)	0.62(21)	0.010(3)
¹⁹¹ Ir	210.352(5)	0.75(8)	0.0118(13)	¹⁹³ Ir	340.8130(20)	0.8(5)	0.013(8)
¹⁹¹ Ir	210.354(5)	0.75(8)	0.0118(13)	¹⁹¹Ir	351.689(4)	10.9(4)	0.172(6)
¹⁹¹Ir	210.354(5)	2.1(4)	0.033(6)	¹⁹³ Ir	353.9610(10)	0.5(3)	0.008(5)
¹⁹³ Ir	212.3460(20)	0.15(10)	0.0024(16)	¹⁹¹ Ir	358.320(8)	0.34(9)	0.0054(14)
¹⁹¹ Ir	215.117(5)	0.23(4)	0.0036(6)	¹⁹¹Ir	365.440(7)	1.15(10)	0.0181(16)
¹⁹¹ Ir	215.5110(20)	0.24(4)	0.0038(6)	¹⁹³Ir	371.5020(20)	2.11(12)	0.0333(19)
¹⁹¹ Ir	216.1940(20)	0.65(9)	0.0102(14)	¹⁹¹ Ir	384.659(6)	0.50(12)	0.0079(19)
¹⁹¹Ir	216.905(4)	5.57(24)	0.088(4)	¹⁹³ Ir	390.9620(10)	0.6(4)	0.009(6)
¹⁹¹ Ir	221.90(10)	0.83(16)	0.0131(25)	¹⁹³ Ir	405.3660(20)	0.11(7)	0.0017(11)
¹⁹¹ Ir	223.176(6)	0.18(3)	0.0028(5)	¹⁹³ Ir	407.3150(20)	0.13(8)	0.0020(13)

^A Z	E _γ -keV	σ _γ ^Z (E _γ)-barns	k ₀	^A Z	E _γ -keV	σ _γ ^Z (E _γ)-barns	k ₀
¹⁹³ Ir	411.988(10)	0.12(8)	0.0019(13)	¹⁹¹ Ir	4985.93(14)	0.58(3)	0.0091(5)
¹⁹¹ Ir	418.138(6)	3.45(15)	0.0544(24)	¹⁹¹ Ir	4993.32(15)	0.40(4)	0.0063(6)
¹⁹¹ Ir	432.716(6)	1.85(7)	0.0292(11)	¹⁹¹ Ir	5003.4(3)	0.35(4)	0.0055(6)
¹⁹³ Ir	458.3070(20)	0.41(25)	0.006(4)	¹⁹³ Ir	5013.8(5)	0.21(4)	0.0033(6)
¹⁹³ Ir	460.2560(20)	0.8(5)	0.013(8)	¹⁹¹ Ir	5020.51(15)	0.66(6)	0.0104(10)
¹⁹³ Ir	4365.1(3)	0.22(3)	0.0035(5)	¹⁹¹ Ir	5028.52(15)	0.67(6)	0.0106(10)
¹⁹³ Ir	4368.5(4)	0.14(3)	0.0022(5)	¹⁹¹ Ir	5037.5(3)	0.22(4)	0.0035(6)
¹⁹³ Ir	4383.5(4)	0.11(3)	0.0017(5)	¹⁹¹ Ir	5042.35(23)	0.57(6)	0.0090(10)
¹⁹³ Ir	4395.64(18)	0.39(3)	0.0061(5)	¹⁹¹ Ir	5046.4(6)	0.12(3)	0.0019(5)
¹⁹³ Ir	4401.28(18)	0.35(3)	0.0055(5)	¹⁹¹ Ir	5053.15(23)	0.26(3)	0.0041(5)
¹⁹³ Ir	4426.1(3)	0.23(3)	0.0036(5)	¹⁹³ Ir	5058.0(3)	0.20(3)	0.0032(5)
¹⁹³ Ir	4442.1(8)	0.14(3)	0.0022(5)	¹⁹¹ Ir	5066.5(3)	0.15(3)	0.0024(5)
¹⁹³ Ir	4455.3(4)	0.13(3)	0.0020(5)	¹⁹³ Ir	5071.99(21)	0.28(3)	0.0044(5)
¹⁹³ Ir	4460.5(4)	0.18(3)	0.0028(5)	¹⁹¹ Ir	5085.45(20)	0.266(25)	0.0042(4)
¹⁹¹ Ir	4495.88(21)	0.44(4)	0.0069(6)	¹⁹¹ Ir	5091.10(18)	0.37(5)	0.0058(8)
¹⁹¹ Ir	4505.9(4)	0.20(3)	0.0032(5)	¹⁹³ Ir	5091.19(17)	0.52(3)	0.0082(5)
¹⁹¹ Ir	4521.3(4)	0.12(4)	0.0019(6)	¹⁹¹ Ir	5104.6(4)	0.14(3)	0.0022(5)
¹⁹¹ Ir	4531.28(19)	0.61(5)	0.0096(8)	¹⁹³ Ir	5109.0(3)	0.19(3)	0.0030(5)
¹⁹¹ Ir	4556.8(8)	0.18(7)	0.0028(11)	¹⁹¹ Ir	5109.6(6)	0.11(7)	0.0017(11)
¹⁹¹ Ir	4563.5(9)	0.14(11)	0.0022(17)	¹⁹³ Ir	5117.9(4)	0.12(3)	0.0019(5)
¹⁹¹ Ir	4571.8(5)	0.23(4)	0.0036(6)	¹⁹¹ Ir	5123.3(3)	0.20(3)	0.0032(5)
¹⁹³ Ir	4577.9(4)	0.16(3)	0.0025(5)	¹⁹¹ Ir	5129.21(12)	0.90(5)	0.0142(8)
¹⁹³ Ir	4584.4(3)	0.21(4)	0.0033(6)	¹⁹¹ Ir	5138.06(14)	0.39(4)	0.0061(6)
¹⁹¹ Ir	4591.30(17)	0.57(4)	0.0090(6)	¹⁹¹ Ir	5147.51(12)	1.29(6)	0.0203(10)
¹⁹¹ Ir	4601.64(24)	0.22(4)	0.0035(6)	¹⁹¹ Ir	5153.1(3)	0.26(3)	0.0041(5)
¹⁹¹ Ir	4611.6(6)	0.11(7)	0.0017(11)	¹⁹³ Ir	5158.23(22)	0.36(3)	0.0057(5)
¹⁹³ Ir	4612.5(3)	0.19(3)	0.0030(5)	¹⁹¹ Ir	5166.92(13)	0.96(6)	0.0151(10)
¹⁹³ Ir	4618.0(4)	0.13(3)	0.0020(5)	¹⁹³ Ir	5178.4(3)	0.34(4)	0.0054(6)
¹⁹¹ Ir	4640.0(6)	0.15(6)	0.0024(10)	¹⁹¹ Ir	5184.38(25)	0.20(6)	0.0032(10)
¹⁹³ Ir	4643.2(3)	0.33(5)	0.0052(8)	¹⁹³ Ir	5185.2(4)	0.34(4)	0.0054(6)
¹⁹¹ Ir	4646.47(13)	0.26(5)	0.0041(8)	¹⁹¹ Ir	5194.52(24)	0.34(5)	0.0054(8)
¹⁹¹ Ir	4663.36(21)	0.18(3)	0.0028(5)	¹⁹¹ Ir	5198.64(21)	0.38(4)	0.0060(6)
¹⁹¹ Ir	4668.09(17)	0.36(3)	0.0057(5)	¹⁹¹ Ir	5219.92(17)	0.72(5)	0.0114(8)
¹⁹³ Ir	4678.7(3)	0.18(3)	0.0028(5)	¹⁹¹ Ir	5248.02(23)	0.20(3)	0.0032(5)
¹⁹¹ Ir	4711.6(4)	0.17(3)	0.0027(5)	¹⁹¹ Ir	5261.14(17)	0.51(4)	0.0080(6)
¹⁹³ Ir	4712.8(3)	0.28(3)	0.0044(5)	¹⁹¹ Ir	5283.60(13)	0.85(6)	0.0134(10)
¹⁹¹ Ir	4729.1(3)	0.167(25)	0.0026(4)	¹⁹¹ Ir	5304.44(13)	0.73(5)	0.0115(8)
¹⁹¹ Ir	4734.2(3)	0.45(9)	0.0071(14)	¹⁹¹ Ir	5313.6(3)	0.15(4)	0.0024(6)
¹⁹³ Ir	4734.52(23)	0.46(3)	0.0073(5)	¹⁹³ Ir	5316.6(3)	0.20(4)	0.0032(6)
¹⁹¹ Ir	4750.18(15)	0.38(3)	0.0060(5)	¹⁹¹ Ir	5327.53(19)	0.71(5)	0.0112(8)
¹⁹¹ Ir	4755.28(20)	0.39(3)	0.0061(5)	¹⁹¹ Ir	5332.49(20)	0.54(5)	0.0085(8)
¹⁹¹ Ir	4765.66(17)	0.245(24)	0.0039(4)	¹⁹¹ Ir	5347.1(3)	0.18(3)	0.0028(5)
¹⁹¹ Ir	4779.82(15)	0.32(3)	0.0050(5)	¹⁹¹ Ir	5357.09(16)	1.03(6)	0.0162(10)
¹⁹¹ Ir	4801.4(3)	0.12(3)	0.0019(5)	¹⁹¹ Ir	5376.11(14)	0.288(24)	0.0045(4)
¹⁹¹ Ir	4809.72(23)	0.44(4)	0.0069(6)	¹⁹¹ Ir	5384.82(20)	0.224(22)	0.0035(4)
¹⁹¹ Ir	4817.3(3)	0.28(4)	0.0044(6)	¹⁹¹ Ir	5400.78(16)	0.40(3)	0.0063(5)
¹⁹¹ Ir	4826.1(4)	0.11(3)	0.0017(5)	¹⁹¹ Ir	5420.57(23)	0.201(22)	0.0032(4)
¹⁹³ Ir	4826.9(4)	0.20(4)	0.0032(6)	¹⁹¹ Ir	5431.34(12)	0.78(4)	0.0123(6)
¹⁹¹ Ir	4838.3(4)	0.15(4)	0.0024(6)	¹⁹¹ Ir	5448.60(17)	0.51(4)	0.0080(6)
¹⁹³ Ir	4839.34(20)	0.41(4)	0.0065(6)	¹⁹¹ Ir	5458.91(18)	0.60(5)	0.0095(8)
¹⁹¹ Ir	4849.6(3)	0.15(3)	0.0024(5)	¹⁹¹ Ir	5463.9(4)	0.31(7)	0.0049(11)
¹⁹¹ Ir	4854.8(5)	0.28(5)	0.0044(8)	¹⁹³ Ir	5467.0(3)	0.59(7)	0.0093(11)
¹⁹³ Ir	4855.5(3)	0.48(4)	0.0076(6)	¹⁹¹ Ir	5483.9(4)	0.17(6)	0.0027(10)
¹⁹¹ Ir	4859.30(23)	0.45(4)	0.0071(6)	¹⁹³ Ir	5487.40(21)	0.58(4)	0.0091(6)
¹⁹¹ Ir	4866.97(12)	0.68(4)	0.0107(6)	¹⁹¹ Ir	5490.1(5)	0.19(3)	0.0030(5)
¹⁹¹ Ir	4875.03(18)	0.33(4)	0.0052(6)	¹⁹¹ Ir	5495.27(23)	0.22(3)	0.0035(5)
¹⁹¹ Ir	4893.82(23)	0.35(3)	0.0055(5)	¹⁹¹ Ir	5517.04(17)	0.76(4)	0.0120(6)
¹⁹¹ Ir	4898.53(19)	0.41(4)	0.0065(6)	¹⁹¹ Ir	5534.73(12)	1.39(6)	0.0219(10)
¹⁹¹ Ir	4916.5(3)	0.29(5)	0.0046(8)	¹⁹¹ Ir	5552.18(21)	0.163(22)	0.0026(4)
¹⁹³ Ir	4921.1(4)	0.18(4)	0.0028(6)	¹⁹¹ Ir	5564.54(14)	1.71(8)	0.0270(13)
¹⁹¹ Ir	4932.9(3)	0.11(4)	0.0017(6)	¹⁹¹ Ir	5569.4(3)	0.67(4)	0.0106(6)
¹⁹¹ Ir	4938.9(3)	0.25(9)	0.0039(14)	¹⁹³ Ir	5576.98(7)	0.121(24)	0.0019(4)
¹⁹¹ Ir	4942.92(18)	0.52(4)	0.0082(6)	¹⁹¹ Ir	5595.63(13)	0.72(4)	0.0114(6)
¹⁹¹ Ir	4949.40(24)	0.31(4)	0.0049(6)	¹⁹¹ Ir	5612.55(12)	1.06(5)	0.0167(8)
¹⁹¹ Ir	4955.2(3)	0.15(7)	0.0024(11)	¹⁹³ Ir	5630.33(7)	0.315(24)	0.0050(4)
¹⁹¹ Ir	4966.5(3)	0.20(3)	0.0032(5)	¹⁹³ Ir	5642.90(7)	0.293(25)	0.0046(4)
¹⁹¹ Ir	4972.12(17)	0.35(3)	0.0055(5)	¹⁹¹ Ir	5654.27(14)	0.39(3)	0.0061(5)
¹⁹¹ Ir	4980.57(15)	0.82(4)	0.0129(6)	¹⁹¹ Ir	5661.00(20)	0.38(3)	0.0060(5)

^A Z	E _γ -keV	σ _γ ^Z (E _γ)-barns	k ₀
¹⁹¹ Ir	5667.81(3)	2.68(10)	0.0423(16)
¹⁹¹ Ir	5681.1(3)	0.165(19)	0.0026(3)
¹⁹¹ Ir	5689.06(3)	1.73(7)	0.0273(11)
¹⁹¹ Ir	5708.62(3)	0.122(17)	0.0019(3)
¹⁹¹ Ir	5727.2(3)	0.27(4)	0.0043(6)
¹⁹³ Ir	5728.97(7)	1.15(5)	0.0181(8)
¹⁹¹ Ir	5746.80(3)	0.190(18)	0.0030(3)
¹⁹¹ Ir	5757.18(3)	0.49(6)	0.0077(10)
¹⁹³ Ir	5757.65(7)	0.42(4)	0.0066(6)
¹⁹¹ Ir	5783.01(3)	1.34(6)	0.0211(10)
¹⁹³ Ir	5788.12(7)	0.43(4)	0.0068(6)
¹⁹¹ Ir	5808.33(3)	0.48(3)	0.0076(5)
¹⁹¹ Ir	5817.7(4)	0.113(25)	0.0018(4)
¹⁹³ Ir	5821.51(7)	0.48(3)	0.0076(5)
¹⁹¹ Ir	5829.70(3)	0.16(5)	0.0025(8)
¹⁹¹ Ir	5866.29(3)	0.73(6)	0.0115(10)
¹⁹¹ Ir	5866.97(3)	0.79(5)	0.0125(8)
¹⁹¹ Ir	5905.67(3)	0.45(4)	0.0071(6)
¹⁹¹ Ir	5909.64(3)	0.23(3)	0.0036(5)
¹⁹³ Ir	5917.68(7)	0.34(3)	0.0054(5)
¹⁹³ Ir	5927.93(7)	0.33(3)	0.0052(5)
¹⁹³ Ir	5954.39(7)	0.74(4)	0.0117(6)
¹⁹¹ Ir	5958.28(3)	1.79(8)	0.0282(13)
¹⁹¹ Ir	5962.29(3)	0.75(4)	0.0118(6)
¹⁹¹ Ir	5972.13(3)	0.254(21)	0.0040(3)
¹⁹³ Ir	5984.28(7)	0.212(21)	0.0033(3)
¹⁹¹ Ir	6004.53(3)	0.257(21)	0.0041(3)
¹⁹³ Ir	6023.50(7)	0.171(17)	0.0027(3)
¹⁹¹ Ir	6079.26(3)	0.29(9)	0.0046(14)
¹⁹¹ Ir	6082.48(3)	2.62(11)	0.0413(17)
¹⁹¹ Ir	6093.26(3)	0.56(4)	0.0088(6)
Platinum (Z=78), At.Wt.=195.078(2), σ_γ=10.3(4)			
¹⁹⁴ Pt	211.4060(20)	0.0293(10)	0.000455(16)
¹⁹⁵ Pt	326.353(3)	0.511(10)	0.00794(16)
¹⁹⁵ Pt	332.985(4)	2.580(25)	0.0401(4)
¹⁹⁵ Pt	355.6840(20)	6.17(6)	0.0958(9)
¹⁹⁵ Pt	393.346(5)	0.066(4)	0.00103(6)
¹⁹⁵ Pt	446.624(4)	0.0963(21)	0.00150(3)
¹⁹⁵ Pt	521.161(5)	0.338(10)	0.00525(16)
¹⁹⁸ Pt	542.98(4)d	0.0390(3)	0.000606[45%]
¹⁹⁵ Pt	672.894(3)	0.179(4)	0.00278(6)
¹⁹⁵ Pt	779.608(5)	0.227(3)	0.00353(5)
¹⁹⁵ Pt	1005.878(5)	0.139(3)	0.00216(5)
¹⁹⁵ Pt	1047.007(11)	0.181(4)	0.00281(6)
¹⁹⁵ Pt	1091.334(6)	0.181(4)	0.00281(6)
¹⁹⁵ Pt	1248.774(10)	0.099(3)	0.00154(5)
¹⁹⁵ Pt	1305.57(3)	0.062(3)	0.00096(5)
¹⁹⁵ Pt	1321.541(15)	0.081(3)	0.00126(5)
¹⁹⁵ Pt	1358.31(6)	0.076(4)	0.00118(6)
¹⁹⁵ Pt	1439.35(5)	0.067(3)	0.00104(5)
¹⁹⁵ Pt	1491.625(16)	0.135(4)	0.00210(6)
¹⁹⁵ Pt	1497.950(11)	0.084(3)	0.00130(5)
¹⁹⁵ Pt	1510.75(5)	0.083(3)	0.00129(5)
¹⁹⁵ Pt	1531.84(3)	0.122(4)	0.00190(6)
¹⁹⁵ Pt	1532.435(12)	0.066(18)	0.0010(3)
¹⁹⁵ Pt	1562.76(4)	0.083(3)	0.00129(5)
¹⁹⁵ Pt	1677.223(15)	0.087(4)	0.00135(6)
¹⁹⁵ Pt	1713.67(10)	0.090(4)	0.00140(6)
¹⁹⁵ Pt	1737.278(16)	0.087(4)	0.00135(6)
¹⁹⁵ Pt	1802.269(10)	0.146(4)	0.00227(6)
¹⁹⁵ Pt	1825.685(8)	0.091(4)	0.00141(6)
¹⁹⁵ Pt	1888.116(12)	0.080(4)	0.00124(6)
¹⁹⁵ Pt	1968.858(13)	0.103(4)	0.00160(6)
¹⁹⁵ Pt	1978.46(3)	0.163(5)	0.00253(8)
¹⁹⁵ Pt	2309.20(9)	0.066(14)	0.00103(22)
¹⁹⁵ Pt	2311.44(3)	0.134(4)	0.00208(6)
¹⁹⁵ Pt	2527.81(3)	0.07(3)	0.0011(5)
¹⁹⁵ Pt	4949.0(4)	0.069(20)	0.0011(3)

^A Z	E _γ -keV	σ _γ ^Z (E _γ)-barns	k ₀
¹⁹⁶ Pt	5098.1(7)	0.093(6)	0.00144(9)
¹⁹⁵ Pt	5098.5(7)	0.10(3)	0.0016(5)
¹⁹⁵ Pt	5173.4(3)	0.136(6)	0.00211(9)
¹⁹⁵ Pt	5185.3(3)	0.085(5)	0.00132(8)
¹⁹⁵ Pt	5254.70(8)	0.41(3)	0.0064(5)
¹⁹⁵ Pt	5261.0(6)	0.097(14)	0.00151(22)
¹⁹⁵ Pt	5306.9(3)	0.118(14)	0.00183(22)
¹⁹⁵ Pt	5393.05(16)	0.113(10)	0.00176(16)
¹⁹⁵ Pt	5451.93(14)	0.078(7)	0.00121(11)
¹⁹⁵ Pt	5612.62(11)	0.14(3)	0.0022(5)
¹⁹⁵ Pt	5722.40(9)	0.071(5)	0.00110(8)
¹⁹⁵ Pt	5759.22(10)	0.084(12)	0.00130(19)
¹⁹⁵ Pt	5952.95(7)	0.086(16)	0.00134(25)
¹⁹⁵ Pt	6003.37(8)	0.073(4)	0.00113(6)
¹⁹⁵ Pt	6033.69(7)	0.109(6)	0.00169(9)
Gold (Z=79), At.Wt.=196.96655(2), σ_γ=98.65(9)			
¹⁹⁷ Au	35.8240(10)	0.41(5)	0.0063(8)
¹⁹⁷ Au	55.1810(10)	2.90(12)	0.0446(18)
¹⁹⁷ Au	66.3950(10)	0.42(12)	0.0065(18)
¹⁹⁷ Au	75.171(6)	0.390(23)	0.0060(4)
¹⁹⁷ Au	82.3560(10)	2.3(4)	0.035(6)
¹⁹⁷ Au	82.5240(10)	1.4(3)	0.022(5)
¹⁹⁷ Au	83.144(6)	0.17(7)	0.0026(11)
¹⁹⁷ Au	91.0050(10)	0.294(15)	0.00452(23)
¹⁹⁷ Au	97.2500(20)	2.1(5)	0.032(8)
¹⁹⁷ Au	101.9390(10)	0.953(17)	0.0147(3)
¹⁹⁷ Au	103.5610(10)	0.338(15)	0.00520(23)
¹⁹⁷ Au	108.9120(20)	0.270(14)	0.00415(22)
¹⁹⁷ Au	122.6520(10)	0.81(13)	0.0125(20)
¹⁹⁷ Au	123.7860(10)	0.83(13)	0.0128(20)
¹⁹⁷ Au	131.9340(20)	0.17(6)	0.0026(9)
¹⁹⁷ Au	132.850(4)	0.104(24)	0.0016(4)
¹⁹⁷ Au	135.612(6)	0.10(3)	0.0015(5)
¹⁹⁷ Au	137.448(6)	0.13(5)	0.0020(8)
¹⁹⁷ Au	137.7630(10)	0.347(24)	0.0053(4)
¹⁹⁷ Au	137.999(5)	0.17(5)	0.0026(8)
¹⁹⁷ Au	142.9270(20)	0.161(16)	0.00248(25)
¹⁹⁷ Au	144.6050(10)	0.18(4)	0.0028(6)
¹⁹⁷ Au	145.1540(10)	0.46(13)	0.0071(20)
¹⁹⁷ Au	146.3460(20)	0.43(4)	0.0066(6)
¹⁹⁷ Au	146.6700(10)	0.28(5)	0.0043(8)
¹⁹⁷ Au	154.7940(20)	0.38(6)	0.0058(9)
¹⁹⁷ Au	154.797(5)	0.239(10)	0.00368(15)
¹⁹⁷ Au	158.4360(10)	1.250(18)	0.0192(3)
¹⁹⁷ Au	158.479(11)	0.67(9)	0.0103(14)
¹⁹⁷ Au	164.7130(10)	0.21(3)	0.0032(5)
¹⁹⁷ Au	166.2280(10)	0.279(11)	0.00429(17)
¹⁹⁷ Au	168.3340(10)	3.60(22)	0.055(3)
¹⁹⁷ Au	169.9550(10)	0.126(25)	0.0019(4)
¹⁹⁷ Au	170.1030(10)	1.66(22)	0.026(3)
¹⁹⁷ Au	170.3990(20)	0.38(5)	0.0058(8)
¹⁹⁷ Au	175.3070(20)	0.10(8)	0.0015(12)
¹⁹⁷ Au	180.8640(10)	0.63(11)	0.0097(17)
¹⁹⁷ Au	188.1670(20)	0.63(15)	0.0097(23)
¹⁹⁷ Au	191.1870(20)	0.18(3)	0.0028(5)
¹⁹⁷ Au	192.3920(10)	3.9(18)	0.06(3)
¹⁹⁷ Au	192.9440(10)	1.70(22)	0.026(3)
¹⁹⁷ Au	202.9920(20)	0.229(6)	0.00352(9)
¹⁹⁷ Au	204.1580(10)	0.513(10)	0.00789(15)
¹⁹⁷ Au	204.1620(10)	0.59(10)	0.0091(15)
¹⁹⁷ Au	206.2230(10)	0.199(6)	0.00306(9)
¹⁹⁷ Au	213.0650(10)	0.094(13)	0.00145(20)
¹⁹⁷ Au	214.858(3)	0.19(5)	0.0029(8)
¹⁹⁷ Au	214.9710(10)	9.0(12)	0.138(18)
¹⁹⁷ Au	215.2950(20)	0.19(3)	0.0029(5)
¹⁹⁷ Au	218.8300(10)	0.141(22)	0.0022(3)
¹⁹⁷ Au	219.4190(20)	0.42(4)	0.0065(6)
¹⁹⁷ Au	234.6000(20)	0.091(12)	0.00140(18)

$^A Z$	E_γ -keV	$\sigma_\gamma^Z(E_\gamma)$ -barns	k_0	$^A Z$	E_γ -keV	$\sigma_\gamma^Z(E_\gamma)$ -barns	k_0
¹⁹⁷ Au	236.0450(10)	4.1(5)	0.063(8)	¹⁹⁷ Au	529.954(4)	0.39(5)	0.0060(8)
¹⁹⁷ Au	236.1710(20)	0.26(6)	0.0040(9)	¹⁹⁷ Au	540.3010(20)	0.49(23)	0.008(4)
¹⁹⁷ Au	245.314(6)	0.111(18)	0.0017(3)	¹⁹⁷ Au	542.3670(20)	0.104(14)	0.00160(22)
¹⁹⁷ Au	247.5730(10)	5.56(8)	0.0855(12)	¹⁹⁷ Au	544.008(5)	0.52(5)	0.0080(8)
¹⁹⁷ Au	248.739(3)	0.111(16)	0.00171(25)	¹⁹⁷ Au	548.9350(20)	0.67(9)	0.0103(14)
¹⁹⁷ Au	260.8820(10)	0.83(13)	0.0128(20)	¹⁹⁷ Au	552.467(3)	0.104(14)	0.00160(22)
¹⁹⁷ Au	261.4040(10)	5.3(20)	0.08(3)	¹⁹⁷ Au	555.6890(20)	0.126(17)	0.0019(3)
¹⁹⁷ Au	266.6470(10)	0.26(3)	0.0040(5)	¹⁹⁷ Au	565.784(5)	0.38(5)	0.0058(8)
¹⁹⁷ Au	269.0730(20)	0.155(24)	0.0024(4)	¹⁹⁷ Au	565.810(3)	0.43(6)	0.0066(9)
¹⁹⁷ Au	271.1380(20)	0.104(16)	0.00160(25)	¹⁹⁷ Au	571.683(3)	0.50(7)	0.0077(11)
¹⁹⁷ Au	271.2280(20)	0.170(24)	0.0026(4)	¹⁹⁷ Au	573.388(13)	0.126(17)	0.0019(3)
¹⁹⁷ Au	271.8940(10)	0.40(13)	0.0062(20)	¹⁹⁷ Au	573.746(6)	0.096(14)	0.00148(22)
¹⁹⁷ Au	276.072(3)	0.226(5)	0.00348(8)	¹⁹⁷ Au	573.960(4)	0.33(4)	0.0051(6)
¹⁹⁷ Au	277.2460(20)	0.277(6)	0.00426(9)	¹⁹⁷ Au	574.370(5)	0.148(20)	0.0023(3)
¹⁹⁷ Au	284.1090(20)	0.16(3)	0.0025(5)	¹⁹⁷ Au	574.381(3)	0.36(5)	0.0055(8)
¹⁹⁷ Au	291.7240(20)	1.05(17)	0.016(3)	¹⁹⁷ Au	574.733(10)	0.104(14)	0.00160(22)
¹⁹⁷ Au	293.1210(20)	0.101(16)	0.00155(25)	¹⁹⁷ Au	577.3020(20)	0.27(3)	0.0042(5)
¹⁹⁷ Au	307.7180(10)	0.44(6)	0.0068(9)	¹⁹⁷ Au	579.297(3)	0.53(8)	0.0082(12)
¹⁹⁷ Au	311.9040(20)	0.47(6)	0.0072(9)	¹⁹⁷ Au	584.800(10)	0.121(15)	0.00186(23)
¹⁹⁷ Au	314.913(3)	0.27(4)	0.0042(6)	¹⁹⁷ Au	593.184(8)	0.148(21)	0.0023(3)
¹⁹⁷ Au	324.900(5)	0.104(14)	0.00160(22)	¹⁹⁷ Au	609.432(4)	0.111(9)	0.00171(14)
¹⁹⁷ Au	328.4840(20)	1.48(19)	0.023(3)	¹⁹⁷ Au	612.7240(20)	0.104(14)	0.00160(22)
¹⁹⁷ Au	328.740(10)	0.111(14)	0.00171(22)	¹⁹⁷ Au	612.799(6)	0.096(22)	0.0015(3)
¹⁹⁷ Au	333.8380(20)	0.111(14)	0.00171(22)	¹⁹⁷ Au	625.4280(20)	0.44(4)	0.0068(6)
¹⁹⁷ Au	337.5330(10)	0.178(23)	0.0027(4)	¹⁹⁷ Au	631.660(9)	0.144(19)	0.0022(3)
¹⁹⁷ Au	339.2910(20)	0.090(25)	0.0014(4)	¹⁹⁷ Au	632.275(3)	0.170(23)	0.0026(4)
¹⁹⁷ Au	346.9050(20)	0.44(11)	0.0068(17)	¹⁹⁷ Au	635.166(3)	0.24(3)	0.0037(5)
¹⁹⁷ Au	347.8800(20)	0.111(14)	0.00171(22)	¹⁹⁷ Au	640.669(3)	0.59(5)	0.0091(8)
¹⁹⁷ Au	350.8280(10)	1.0(5)	0.015(8)	¹⁹⁷ Au	647.293(5)	0.126(17)	0.0019(3)
¹⁹⁷ Au	355.5300(20)	0.31(4)	0.0048(6)	¹⁹⁷ Au	655.528(4)	0.21(3)	0.0032(5)
¹⁹⁷ Au	364.0240(20)	0.11(3)	0.0017(5)	¹⁹⁷ Au	655.569(3)	0.24(5)	0.0037(8)
¹⁹⁷ Au	364.030(6)	0.104(14)	0.00160(22)	¹⁹⁷ Au	659.2490(20)	0.25(6)	0.0038(9)
¹⁹⁷ Au	368.2510(20)	0.133(21)	0.0020(3)	¹⁹⁷ Au	661.451(10)	0.093(19)	0.0014(3)
¹⁹⁷ Au	371.0790(20)	0.44(6)	0.0068(9)	¹⁹⁷ Au	668.561(7)	0.163(22)	0.0025(3)
¹⁹⁷ Au	373.1450(20)	0.130(19)	0.0020(3)	¹⁹⁷ Au	672.6550(10)	0.55(7)	0.0085(11)
¹⁹⁷ Au	378.2990(20)	0.178(23)	0.0027(4)	¹⁹⁷ Au	673.503(8)	0.126(18)	0.0019(3)
¹⁹⁷ Au	381.1990(10)	3.0(4)	0.046(6)	¹⁹⁷ Au	678.208(10)	0.41(12)	0.0063(18)
¹⁹⁷ Au	383.284(4)	0.24(3)	0.0037(5)	¹⁹⁷ Au	680.391(6)	0.10(3)	0.0015(5)
¹⁹⁷ Au	393.884(5)	0.22(3)	0.0034(5)	¹⁹⁷ Au	682.804(5)	0.111(15)	0.00171(23)
¹⁹⁷ Au	396.104(4)	0.100(8)	0.00154(12)	¹⁹⁷ Au	686.865(5)	0.218(18)	0.0034(3)
¹⁹⁷ Au	398.295(6)	0.096(13)	0.00148(20)	¹⁹⁷ Au	688.968(10)	0.155(24)	0.0024(4)
¹⁹⁷ Au	411.802d	94.29(15)	1.453(23)	¹⁹⁷ Au	690.046(6)	0.388(20)	0.0060(3)
¹⁹⁷ Au	418.8400(20)	0.70(9)	0.0108(14)	¹⁹⁷ Au	692.972(6)	0.094(18)	0.0014(3)
¹⁹⁷ Au	440.3290(20)	0.9(4)	0.014(6)	¹⁹⁷ Au	698.287(4)	0.15(5)	0.0023(8)
¹⁹⁷ Au	441.070(5)	0.7(5)	0.011(8)	¹⁹⁷ Au	702.474(5)	0.51(7)	0.0078(11)
¹⁹⁷ Au	444.3910(20)	0.56(7)	0.0086(11)	¹⁹⁷ Au	724.623(6)	0.115(18)	0.0018(3)
¹⁹⁷ Au	447.527(3)	0.10(4)	0.0015(6)	¹⁹⁷ Au	728.239(6)	0.161(19)	0.0025(3)
¹⁹⁷ Au	448.562(7)	0.118(15)	0.00182(23)	¹⁹⁷ Au	728.997(6)	0.111(20)	0.0017(3)
¹⁹⁷ Au	449.5700(20)	0.50(6)	0.0077(9)	¹⁹⁷ Au	732.221(10)	0.104(14)	0.00160(22)
¹⁹⁷ Au	456.1570(20)	0.141(22)	0.0022(3)	¹⁹⁷ Au	740.0000(20)	0.310(21)	0.0048(3)
¹⁹⁷ Au	456.287(4)	0.47(6)	0.0072(9)	¹⁹⁷ Au	744.8580(20)	0.104(15)	0.00160(23)
¹⁹⁷ Au	458.0540(20)	0.29(4)	0.0045(6)	¹⁹⁷ Au	745.220(4)	0.33(6)	0.0051(9)
¹⁹⁷ Au	458.370(4)	0.16(3)	0.0025(5)	¹⁹⁷ Au	746.073(5)	0.133(18)	0.0020(3)
¹⁹⁷ Au	464.7620(20)	0.17(6)	0.0026(9)	¹⁹⁷ Au	764.011(3)	0.3(3)	0.005(5)
¹⁹⁷ Au	485.638(5)	0.16(3)	0.0025(5)	¹⁹⁷ Au	765.131(6)	0.163(22)	0.0025(3)
¹⁹⁷ Au	502.407(8)	0.16(4)	0.0025(6)	¹⁹⁷ Au	767.886(5)	0.096(14)	0.00148(22)
¹⁹⁷ Au	509.175(4)	0.37(9)	0.0057(14)	¹⁹⁷ Au	767.960(6)	0.096(14)	0.00148(22)
¹⁹⁷ Au	510.427(6)	0.19(7)	0.0029(11)	¹⁹⁷ Au	770.858(5)	0.206(17)	0.0032(3)
¹⁹⁷ Au	511.067(6)	0.111(22)	0.0017(3)	¹⁹⁷ Au	776.632(6)	0.118(19)	0.0018(3)
¹⁹⁷ Au	511.5170(20)	0.68(11)	0.0105(17)	¹⁹⁷ Au	783.230(5)	0.111(23)	0.0017(4)
¹⁹⁷ Au	512.5790(20)	0.16(6)	0.0025(9)	¹⁹⁷ Au	786.793(10)	0.261(15)	0.00402(23)
¹⁹⁷ Au	515.132(6)	0.104(14)	0.00160(22)	¹⁹⁷ Au	788.131(13)	0.104(19)	0.0016(3)
¹⁹⁷ Au	516.0620(10)	0.35(5)	0.0054(8)	¹⁹⁷ Au	794.158(7)	0.178(24)	0.0027(4)
¹⁹⁷ Au	520.746(6)	0.19(8)	0.0029(12)	¹⁹⁷ Au	796.217(5)	0.148(22)	0.0023(3)
¹⁹⁷ Au	522.351(4)	0.096(12)	0.00148(18)	¹⁹⁷ Au	801.7050(20)	0.19(4)	0.0029(6)
¹⁹⁷ Au	524.752(3)	0.27(8)	0.0042(12)	¹⁹⁷ Au	806.248(8)	0.13(3)	0.0020(5)
¹⁹⁷ Au	525.1340(20)	0.35(4)	0.0054(6)	¹⁹⁷ Au	810.100(7)	0.26(3)	0.0040(5)
¹⁹⁷ Au	529.1650(20)	1.9(10)	0.029(15)	¹⁹⁷ Au	815.954(7)	0.104(20)	0.0016(3)

^A Z	E _γ -keV	σ _γ ^Z (E _γ)-barns	k ₀	^A Z	E _γ -keV	σ _γ ^Z (E _γ)-barns	k ₀
¹⁹⁷ Au	822.572(5)	0.104(17)	0.0016(3)	¹⁹⁷ Au	1195.597(6)	0.148(22)	0.0023(3)
¹⁹⁷ Au	825.483(4)	0.31(5)	0.0048(8)	¹⁹⁷ Au	1200.827(8)	0.104(16)	0.00160(25)
¹⁹⁷ Au	831.470(5)	0.153(19)	0.0024(3)	¹⁹⁷ Au	1210.691(4)	0.20(3)	0.0031(5)
¹⁹⁷ Au	833.906(6)	0.104(16)	0.00160(25)	¹⁹⁷ Au	1216.453(5)	0.21(3)	0.0032(5)
¹⁹⁷ Au	836.432(3)	0.76(3)	0.0117(5)	¹⁹⁷ Au	1225.938(6)	0.27(4)	0.0042(6)
¹⁹⁷ Au	838.156(5)	0.13(3)	0.0020(5)	¹⁹⁷ Au	1239.572(5)	0.49(8)	0.0075(12)
¹⁹⁷ Au	839.516(5)	0.73(20)	0.011(3)	¹⁹⁷ Au	1252.166(9)	0.126(23)	0.0019(4)
¹⁹⁷ Au	846.216(7)	0.104(24)	0.0016(4)	¹⁹⁷ Au	1272.140(5)	0.096(16)	0.00148(25)
¹⁹⁷ Au	854.178(6)	0.093(18)	0.0014(3)	¹⁹⁷ Au	1274.975(5)	0.26(4)	0.0040(6)
¹⁹⁷ Au	854.650(4)	0.148(25)	0.0023(4)	¹⁹⁷ Au	1281.377(7)	0.49(12)	0.0075(18)
¹⁹⁷ Au	863.082(6)	0.148(25)	0.0023(4)	¹⁹⁷ Au	1283.442(7)	0.35(11)	0.0054(17)
¹⁹⁷ Au	868.771(4)	0.364(15)	0.00560(23)	¹⁹⁷ Au	1297.124(6)	0.43(10)	0.0066(15)
¹⁹⁷ Au	872.827(4)	0.096(18)	0.0015(3)	¹⁹⁷ Au	1301.041(6)	0.15(6)	0.0023(9)
¹⁹⁷ Au	877.308(4)	0.21(5)	0.0032(8)	¹⁹⁷ Au	1304.825(5)	0.25(5)	0.0038(8)
¹⁹⁷ Au	885.638(6)	0.17(3)	0.0026(5)	¹⁹⁷ Au	1306.851(5)	0.70(9)	0.0108(14)
¹⁹⁷ Au	891.613(3)	0.096(23)	0.0015(4)	¹⁹⁷ Au	1308.164(4)	0.118(25)	0.0018(4)
¹⁹⁷ Au	898.612(4)	0.15(3)	0.0023(5)	¹⁹⁷ Au	1316.318(5)	0.21(4)	0.0032(6)
¹⁹⁷ Au	902.478(6)	0.38(6)	0.0058(9)	¹⁹⁷ Au	1324.356(14)	0.19(3)	0.0029(5)
¹⁹⁷ Au	913.776(4)	0.30(6)	0.0046(9)	¹⁹⁷ Au	1335.515(12)	0.16(4)	0.0025(6)
¹⁹⁷ Au	916.435(6)	0.25(4)	0.0038(6)	¹⁹⁷ Au	1338.164(5)	0.118(22)	0.0018(3)
¹⁹⁷ Au	927.421(4)	0.31(12)	0.0048(18)	¹⁹⁷ Au	1344.153(6)	0.16(3)	0.0025(5)
¹⁹⁷ Au	928.995(6)	0.126(22)	0.0019(3)	¹⁹⁷ Au	1361.477(5)	0.27(4)	0.0042(6)
¹⁹⁷ Au	933.928(6)	0.47(14)	0.0072(22)	¹⁹⁷ Au	1363.345(4)	0.26(4)	0.0040(6)
¹⁹⁷ Au	946.453(5)	0.096(13)	0.00148(20)	¹⁹⁷ Au	1379.390(6)	0.141(22)	0.0022(3)
¹⁹⁷ Au	947.971(6)	0.32(4)	0.0049(6)	¹⁹⁷ Au	1396.133(6)	0.141(22)	0.0022(3)
¹⁹⁷ Au	952.503(7)	0.19(3)	0.0029(5)	¹⁹⁷ Au	1431.641(6)	0.15(4)	0.0023(6)
¹⁹⁷ Au	971.8180(20)	0.13(4)	0.0020(6)	¹⁹⁷ Au	1431.949(4)	0.23(4)	0.0035(6)
¹⁹⁷ Au	978.936(8)	0.141(20)	0.0022(3)	¹⁹⁷ Au	1445.373(5)	0.14(3)	0.0022(5)
¹⁹⁷ Au	983.082(7)	0.096(14)	0.00148(22)	¹⁹⁷ Au	1487.130(4)	0.20(4)	0.0031(6)
¹⁹⁷ Au	985.002(6)	0.104(25)	0.0016(4)	¹⁹⁷ Au	1487.599(7)	0.20(4)	0.0031(6)
¹⁹⁷ Au	993.654(6)	0.21(5)	0.0032(8)	¹⁹⁷ Au	1530.698(6)	0.30(5)	0.0046(8)
¹⁹⁷ Au	999.682(4)	0.23(3)	0.0035(5)	¹⁹⁷ Au	1554.420(5)	0.25(9)	0.0038(14)
¹⁹⁷ Au	1000.447(4)	0.104(22)	0.0016(3)	¹⁹⁷ Au	4951.85(10)	0.156(16)	0.00240(25)
¹⁹⁷ Au	1005.487(6)	0.133(24)	0.0020(4)	¹⁹⁷ Au	4957.83(10)	0.63(11)	0.0097(17)
¹⁹⁷ Au	1006.100(3)	0.096(15)	0.00148(23)	¹⁹⁷ Au	4975.87(10)	0.161(16)	0.00248(25)
¹⁹⁷ Au	1018.136(6)	0.11(3)	0.0017(5)	¹⁹⁷ Au	4981.55(10)	0.09(3)	0.0014(5)
¹⁹⁷ Au	1018.426(4)	0.18(3)	0.0028(5)	¹⁹⁷ Au	4998.68(10)	0.31(4)	0.0048(6)
¹⁹⁷ Au	1028.199(5)	0.10(3)	0.0015(5)	¹⁹⁷ Au	5007.08(10)	0.113(15)	0.00174(23)
¹⁹⁷ Au	1028.564(6)	0.46(7)	0.0071(11)	¹⁹⁷ Au	5025.11(10)	0.113(16)	0.00174(25)
¹⁹⁷ Au	1038.274(3)	0.184(14)	0.00283(22)	¹⁹⁷ Au	5036.63(10)	0.18(7)	0.0028(11)
¹⁹⁷ Au	1046.323(7)	0.111(16)	0.00171(25)	¹⁹⁷ Au	5040.15(10)	0.18(7)	0.0028(11)
¹⁹⁷ Au	1047.121(6)	0.155(20)	0.0024(3)	¹⁹⁷ Au	5080.60(10)	0.152(15)	0.00234(23)
¹⁹⁷ Au	1047.847(5)	0.096(14)	0.00148(22)	¹⁹⁷ Au	5088.46(10)	0.50(8)	0.0077(12)
¹⁹⁷ Au	1049.231(6)	0.104(17)	0.0016(3)	¹⁹⁷ Au	5102.85(10)	0.87(13)	0.0134(20)
¹⁹⁷ Au	1050.701(5)	0.28(5)	0.0043(8)	¹⁹⁷ Au	5110.17(10)	0.156(11)	0.00240(17)
¹⁹⁷ Au	1054.055(5)	0.16(3)	0.0025(5)	¹⁹⁷ Au	5116.11(10)	0.161(13)	0.00248(20)
¹⁹⁷ Au	1060.888(7)	0.19(3)	0.0029(5)	¹⁹⁷ Au	5140.74(10)	0.395(18)	0.0061(3)
¹⁹⁷ Au	1064.436(8)	0.096(13)	0.00148(20)	¹⁹⁷ Au	5148.90(10)	0.46(8)	0.0071(12)
¹⁹⁷ Au	1064.998(7)	0.15(4)	0.0023(6)	¹⁹⁷ Au	5153.21(10)	0.119(14)	0.00183(22)
¹⁹⁷ Au	1076.761(5)	0.111(21)	0.0017(3)	¹⁹⁷ Au	5174.08(10)	0.334(16)	0.00514(25)
¹⁹⁷ Au	1079.197(5)	0.24(4)	0.0037(6)	¹⁹⁷ Au	5205.39(10)	0.16(6)	0.0025(9)
¹⁹⁷ Au	1081.54(4)	0.096(25)	0.0015(4)	¹⁹⁷ Au	5218.35(10)	0.272(20)	0.0042(3)
¹⁹⁷ Au	1085.605(5)	0.19(3)	0.0029(5)	¹⁹⁷ Au	5225.49(10)	0.42(9)	0.0065(14)
¹⁹⁷ Au	1101.942(4)	0.170(23)	0.0026(4)	¹⁹⁷ Au	5246.72(10)	0.51(20)	0.008(3)
¹⁹⁷ Au	1106.951(5)	0.19(4)	0.0029(6)	¹⁹⁷ Au	5271.86(10)	0.38(20)	0.006(3)
¹⁹⁷ Au	1107.562(9)	0.52(10)	0.0080(15)	¹⁹⁷ Au	5279.44(10)	0.524(20)	0.0081(3)
¹⁹⁷ Au	1109.196(4)	0.49(10)	0.0075(15)	¹⁹⁷ Au	5302.86(10)	0.19(10)	0.0029(15)
¹⁹⁷ Au	1111.461(7)	0.37(6)	0.0057(9)	¹⁹⁷ Au	5355.00(10)	0.401(16)	0.00617(25)
¹⁹⁷ Au	1114.585(6)	0.178(24)	0.0027(4)	¹⁹⁷ Au	5473.96(10)	0.21(6)	0.0032(9)
¹⁹⁷ Au	1128.417(6)	0.141(19)	0.0022(3)	¹⁹⁷ Au	5493.81(10)	0.42(10)	0.0065(15)
¹⁹⁷ Au	1132.895(8)	0.25(5)	0.0038(8)	¹⁹⁷ Au	5524.66(10)	0.80(14)	0.0123(22)
¹⁹⁷ Au	1148.562(6)	0.27(4)	0.0042(6)	¹⁹⁷ Au	5540.41(10)	0.17(6)	0.0026(9)
¹⁹⁷ Au	1150.671(9)	0.25(4)	0.0038(6)	¹⁹⁷ Au	5620.62(10)	0.34(9)	0.0052(14)
¹⁹⁷ Au	1157.2330(20)	0.13(4)	0.0020(6)	¹⁹⁷Au	5710.52(10)	1.27(17)	0.020(3)
¹⁹⁷ Au	1179.882(7)	0.12(5)	0.0018(8)	¹⁹⁷ Au	5722.94(10)	0.55(16)	0.0085(25)
¹⁹⁷ Au	1183.796(6)	0.32(5)	0.0049(8)	¹⁹⁷ Au	5767.01(10)	0.09(3)	0.0014(5)
¹⁹⁷ Au	1187.936(4)	0.15(4)	0.0023(6)	¹⁹⁷ Au	5808.50(10)	0.24(9)	0.0037(14)
¹⁹⁷ Au	1189.904(10)	0.10(3)	0.0015(5)	¹⁹⁷ Au	5839.57(10)	0.16(8)	0.0025(12)

^A Z	E _γ -keV	σ _γ ^z (E _γ)-barns	k ₀	^A Z	E _γ -keV	σ _γ ^z (E _γ)-barns	k ₀
¹⁹⁷ Au	5879.74(10)	0.30(8)	0.0046(12)	²⁰³ Tl	178.78(11)	0.0050(5)	7.4(7)E-5
Mercury (Z=80), At.Wt.=200.59(2), σ_γ^z=384(8)				²⁰³ Tl	198.33(8)	0.0408(10)	0.000605(15)
¹⁹⁶ Hg	133.98(5)d	0.0155(4)	2.34E-4[1.4%]	²⁰⁵ Tl	265.86(9)	0.0210(7)	0.000311(10)
¹⁹⁶ Hg	308.07(11)	0.79(7)	0.0119(11)	²⁰³ Tl	284.81(12)	0.0052(5)	7.7(7)E-5
¹⁹⁹ Hg	367.947(9)	251(5)	3.79(8)	²⁰³ Tl	286.88(11)	0.0058(5)	8.6(7)E-5
²⁰¹ Hg	439.50(8)	0.52(7)	0.0079(11)	²⁰³ Tl	292.26(8)	0.0983(20)	0.00146(3)
¹⁹⁹ Hg	540.927(7)	2.75(9)	0.0415(14)	²⁰⁵ Tl	304.86(9)	0.0225(12)	0.000334(18)
¹⁹⁹ Hg	579.295(11)	7.64(23)	0.115(4)	²⁰³ Tl	310.31(9)	0.0245(12)	0.000363(18)
¹⁹⁹ Hg	661.403(11)	22.3(5)	0.337(8)	²⁰³ Tl	318.88(8)	0.325(6)	0.00482(9)
¹⁹⁹ Hg	688.953(7)	2.83(11)	0.0428(17)	²⁰³ Tl	325.85(8)	0.0301(10)	0.000446(15)
¹⁹⁹ Hg	851.30(5)	2.69(9)	0.0406(14)	²⁰³ Tl	330.09(9)	0.0267(10)	0.000396(15)
¹⁹⁹ Hg	886.153(10)	13.5(11)	0.204(17)	²⁰⁵ Tl	330.09(9)	0.0267(10)	0.000396(15)
¹⁹⁹ Hg	1147.222(11)	7.79(23)	0.118(4)	²⁰³ Tl	331.76(9)	0.0371(10)	0.000550(15)
¹⁹⁹ Hg	1202.328(10)	12.0(3)	0.181(5)	²⁰³ Tl	336.96(10)	0.0080(6)	1.19(9)E-4
¹⁹⁹ Hg	1205.717(11)	13.5(5)	0.204(8)	²⁰³ Tl	347.96(8)	0.361(10)	0.00535(15)
¹⁹⁹ Hg	1225.476(11)	12.3(3)	0.186(5)	²⁰⁵ Tl	369.18(7)	0.016(3)	2.4(4)E-4
¹⁹⁹ Hg	1254.099(12)	7.56(23)	0.114(4)	²⁰³ Tl	369.65(24)	0.0047(12)	7.0(18)E-5
¹⁹⁹ Hg	1262.941(11)	21.5(5)	0.325(8)	²⁰³ Tl	383.99(8)	0.0341(12)	0.000506(18)
¹⁹⁹ Hg	1273.497(10)	10.6(3)	0.160(5)	²⁰³ Tl	389.48(11)	0.0079(7)	1.17(10)E-4
¹⁹⁹ Hg	1350.354(10)	4.10(16)	0.0619(24)	²⁰³ Tl	395.62(8)	0.0862(20)	0.00128(3)
¹⁹⁹ Hg	1362.971(10)	5.93(19)	0.090(3)	²⁰³ Tl	416.91(17)	0.0069(12)	1.02(18)E-4
¹⁹⁹ Hg	1407.942(20)	9.53(23)	0.144(4)	²⁰³ Tl	418.27(11)	0.0141(12)	2.09(18)E-4
¹⁹⁹ Hg	1467.92(5)	3.31(13)	0.0500(20)	²⁰³ Tl	424.81(8)	0.1200(25)	0.00178(4)
¹⁹⁹ Hg	1488.825(11)	2.92(14)	0.0441(21)	²⁰³ Tl	471.90(8)	0.116(3)	0.00172(4)
¹⁹⁹ Hg	1514.903(10)	2.68(13)	0.0405(20)	²⁰³ Tl	483.29(12)	0.0082(10)	1.22(15)E-4
¹⁹⁹ Hg	1557.65(9)	2.6(8)	0.039(12)	²⁰³ Tl	488.11(8)	0.096(4)	0.00142(6)
¹⁹⁹ Hg	1557.94(4)	2.87(14)	0.0434(21)	²⁰³ Tl	489.26(24)	0.008(3)	1.2(4)E-4
¹⁹⁹ Hg	1570.273(12)	29.6(7)	0.447(11)	²⁰³ Tl	563.21(8)	0.0356(15)	0.000528(22)
¹⁹⁹ Hg	1604.322(11)	4.07(17)	0.061(3)	²⁰³ Tl	587.01(10)	0.0109(10)	1.62(15)E-4
¹⁹⁹ Hg	1693.296(11)	56.2(16)	0.849(24)	²⁰³ Tl	591.13(9)	0.0225(10)	0.000334(15)
¹⁹⁹ Hg	1718.299(12)	8.47(23)	0.128(4)	²⁰³ Tl	624.46(8)	0.0413(10)	0.000612(15)
¹⁹⁹ Hg	1758.97(6)	3.33(14)	0.0503(21)	²⁰³ Tl	626.54(8)	0.0388(10)	0.000575(15)
¹⁹⁹ Hg	2002.083(13)	24.3(9)	0.367(14)	²⁰³ Tl	629.12(8)	0.0388(10)	0.000575(15)
¹⁹⁹ Hg	2271.90(3)	6.05(23)	0.091(4)	²⁰⁵ Tl	649.30(15)	0.0106(10)	1.57(15)E-4
¹⁹⁹ Hg	2296.310(23)	2.89(17)	0.044(3)	²⁰³ Tl	678.01(8)	0.0361(15)	0.000535(22)
¹⁹⁹ Hg	2639.85(3)	11.6(3)	0.175(5)	²⁰³ Tl	714.86(24)	0.0074(12)	1.10(18)E-4
¹⁹⁹ Hg	2818.26(5)	3.42(16)	0.0517(24)	²⁰³ Tl	732.09(9)	0.064(3)	0.00095(4)
¹⁹⁹ Hg	2901.25(5)	4.63(19)	0.070(3)	²⁰³ Tl	737.12(8)	0.118(5)	0.00175(7)
¹⁹⁹ Hg	2920.90(4)	4.99(23)	0.075(4)	²⁰³ Tl	764.13(9)	0.0316(12)	0.000469(18)
¹⁹⁹ Hg	3186.21(5)	11.3(4)	0.171(6)	²⁰⁵ Tl	803.30(20)d	3.5(6)E-6	5.2E-8[90%]
¹⁹⁹ Hg	3216.63(9)	2.93(17)	0.044(3)	²⁰³ Tl	818.14(8)	0.0279(10)	0.000414(15)
¹⁹⁹ Hg	3269.19(5)	3.96(18)	0.060(3)	²⁰³ Tl	873.16(8)	0.168(4)	0.00249(6)
¹⁹⁹ Hg	3288.85(4)	13.3(4)	0.201(6)	²⁰³ Tl	931.39(8)	0.0257(12)	0.000381(18)
¹⁹⁹ Hg	4373.37(8)	3.70(23)	0.056(4)	²⁰³ Tl	949.88(8)	0.0479(15)	0.000710(22)
¹⁹⁹ Hg	4575.36(6)	4.23(23)	0.064(4)	²⁰³ Tl	1013.27(9)	0.0217(12)	0.000322(18)
¹⁹⁹ Hg	4675.44(9)	13.0(4)	0.196(6)	²⁰³ Tl	1063.00(9)	0.0185(10)	0.000274(15)
¹⁹⁹ Hg	4739.43(5)	30.1(8)	0.455(12)	²⁰³ Tl	1093.02(8)	0.0353(12)	0.000523(18)
¹⁹⁹ Hg	4759.09(6)	12.4(4)	0.187(6)	²⁰³ Tl	1110.37(8)	0.0413(12)	0.000612(18)
¹⁹⁹ Hg	4811.64(9)	3.70(23)	0.056(4)	²⁰³ Tl	1121.29(7)	0.0600(17)	0.000890(25)
¹⁹⁹ Hg	4842.07(6)	20.0(6)	0.302(9)	²⁰³ Tl	1134.01(9)	0.0133(7)	1.97(10)E-4
¹⁹⁹ Hg	4954.47(5)	4.01(23)	0.061(4)	²⁰³ Tl	1155.43(7)	0.0605(17)	0.000897(25)
¹⁹⁹ Hg	4974.98(7)	5.22(23)	0.079(4)	²⁰³ Tl	1182.6(4)	0.0052(12)	7.7(18)E-5
¹⁹⁹ Hg	5050.07(5)	20.0(6)	0.302(9)	²⁰³ Tl	1234.69(7)	0.0746(25)	0.00111(4)
¹⁹⁹ Hg	5388.43(5)	17.5(5)	0.264(8)	²⁰³ Tl	1478.77(8)	0.0544(22)	0.00081(3)
¹⁹⁹ Hg	5658.24(4)	27.5(7)	0.415(11)	²⁰³ Tl	1706.20(16)	0.0091(15)	1.35(22)E-4
¹⁹⁹ Hg	5967.02(4)	62.5(15)	0.944(23)	²⁰³ Tl	1741.01(8)	0.0548(25)	0.00081(4)
¹⁹⁹ Hg	6309.96(4)	4.0(3)	0.060(5)	²⁰³ Tl	1756.27(12)	0.027(3)	0.00040(4)
¹⁹⁹ Hg	6397.37(4)	3.7(3)	0.056(5)	²⁰³ Tl	4076.7(6)	0.0072(15)	1.07(22)E-4
¹⁹⁹ Hg	6457.98(4)	23.1(8)	0.349(12)	²⁰³ Tl	4101.4(4)	0.0086(25)	1.3(4)E-4
Thallium (Z=81), At.Wt.=204.3833(2), σ_γ^z=3.44(6)				²⁰³ Tl	4115.08(17)	0.0222(17)	0.000329(25)
²⁰³ Tl	77.07(22)	0.011(5)	1.6(7)E-4	²⁰³ Tl	4195.98(14)	0.0373(22)	0.00055(3)
²⁰³ Tl	132.11(14)	0.0062(10)	9.2(15)E-5	²⁰³ Tl	4225.47(17)	0.045(3)	0.00067(4)
²⁰³ Tl	139.94(9)	0.400(7)	0.00593(10)	²⁰³ Tl	4286.3(8)	0.0057(15)	8.5(22)E-5
²⁰³ Tl	145.88(10)	0.0054(5)	8.0(7)E-5	²⁰³ Tl	4309.00(24)	0.0210(22)	0.00031(3)
²⁰³ Tl	152.93(11)	0.0144(6)	2.14(9)E-4	²⁰³ Tl	4343.56(12)	0.034(3)	0.00050(4)
²⁰³ Tl	154.01(9)	0.0926(17)	0.001373(25)	²⁰³ Tl	4402.60(15)	0.0208(15)	0.000308(22)
²⁰³ Tl	157.32(10)	0.0061(5)	9.0(7)E-5	²⁰³ Tl	4439.3(3)	0.0094(15)	1.39(22)E-4
²⁰³ Tl	171.88(9)	0.0109(5)	1.62(7)E-4	²⁰³ Tl	4495.74(13)	0.043(4)	0.00064(6)

^A Z	E _γ -keV	σ _γ ^Z (E _γ)-barns	k ₀
²⁰³ Tl	4540.62(15)	0.0413(25)	0.00061(4)
²⁰³ Tl	4570.0(3)	0.0180(20)	0.00027(3)
²⁰³ Tl	4600.95(16)	0.0292(22)	0.00043(3)
²⁰³ Tl	4687.58(12)	0.098(4)	0.00145(6)
²⁰³ Tl	4705.83(14)	0.058(3)	0.00086(4)
²⁰³ Tl	4715.3(4)	0.0131(20)	1.9(3)E-4
²⁰³ Tl	4752.24(11)	0.148(5)	0.00219(7)
²⁰³ Tl	4804.4(4)	0.0138(20)	2.0(3)E-4
²⁰³ Tl	4841.40(15)	0.090(4)	0.00133(6)
²⁰³ Tl	4867.5(6)	0.0074(20)	1.1(3)E-4
²⁰³ Tl	4913.57(11)	0.164(5)	0.00243(7)
²⁰³ Tl	4980.97(20)	0.036(3)	0.00053(4)
²⁰³ Tl	5014.61(15)	0.058(3)	0.00086(4)
²⁰³ Tl	5130.50(23)	0.058(4)	0.00086(6)
²⁰³ Tl	5180.38(12)	0.141(5)	0.00209(7)
²⁰³ Tl	5238.4(3)	0.0156(20)	2.3(3)E-4
²⁰³ Tl	5261.48(13)	0.084(4)	0.00125(6)
²⁰³ Tl	5279.86(12)	0.207(6)	0.00307(9)
²⁰³ Tl	5404.41(12)	0.147(5)	0.00218(7)
²⁰³ Tl	5451.07(14)	0.079(3)	0.00117(4)
²⁰³ Tl	5520.3(4)	0.0183(25)	0.00027(4)
²⁰³ Tl	5533.35(13)	0.131(5)	0.00194(7)
²⁰³ Tl	5603.28(13)	0.282(10)	0.00418(15)
²⁰³ Tl	5641.57(12)	0.316(7)	0.00469(10)
²⁰⁵ Tl	5852.5(5)	0.0072(15)	1.07(22)E-4
²⁰⁵ Tl	5867.8(4)	0.0091(17)	1.35(25)E-4
²⁰³ Tl	5890.2(4)	0.0067(17)	9.9(25)E-5
²⁰³ Tl	5917.48(16)	0.084(4)	0.00125(6)
²⁰³ Tl	6025.21(24)	0.0222(25)	0.00033(4)
²⁰³ Tl	6118.79(23)	0.0232(20)	0.00034(3)
²⁰³ Tl	6166.61(14)	0.166(6)	0.00246(9)
²⁰³ Tl	6183.05(15)	0.081(4)	0.00120(6)
²⁰⁵ Tl	6197.8(4)	0.0109(17)	1.62(25)E-4
²⁰³ Tl	6222.57(16)	0.065(4)	0.00096(6)
²⁰³ Tl	6336.11(22)	0.0245(22)	0.00036(3)
²⁰⁵ Tl	6504.3(6)	0.0040(10)	5.9(15)E-5
²⁰³ Tl	6514.57(15)	0.129(5)	0.00191(7)
²⁰³ Tl	6654.71(25)	0.0104(12)	1.54(18)E-4
Lead (Z=82), At.Wt.=207.2(1), σ_γ^Z=0.154(7)			
²⁰⁶ Pb	569.702d	0.0014(3)	2.0E-5[100%]
²⁰⁴ Pb	6729.38(9)	0.00320(10)	4.68(15)E-5
²⁰⁶ Pb	6737.62(10)	0.00691(19)	1.01(3)E-4
²⁰⁷ Pb	7367.78(7)	0.137(3)	0.00200(4)
Bismuth (Z=83), At.Wt.=208.98038(2), σ_γ^Z=0.0338(7)			
²⁰⁹ Bi	46.58(12)	0.00043(9)	6.2(13)E-6
²⁰⁹ Bi	63.59(5)	1.8(4)E-4	2.6(6)E-6
²⁰⁹ Bi	64.94(6)	2.1(13)E-4	3.0(19)E-6
²⁰⁹ Bi	65.24(20)	1.8(4)E-4	2.6(6)E-6
²⁰⁹ Bi	91.29(5)	0.0005(3)	7(4)E-6
²⁰⁹ Bi	92.48(13)	2.5(4)E-4	3.6(6)E-6
²⁰⁹ Bi	116.49(9)	0.00054(21)	8(3)E-6
²⁰⁹ Bi	154.86(6)	2.5(4)E-4	3.6(6)E-6
²⁰⁹ Bi	154.89(5)	0.0013(5)	1.9(7)E-5
²⁰⁹ Bi	162.19(11)	0.008(3)	1.2(4)E-4
²⁰⁹ Bi	162.27(6)	0.00162(21)	2.3(3)E-5
²⁰⁹ Bi	183.04(6)	1.8(8)E-4	2.6(12)E-6
²⁰⁹ Bi	311.23(11)	2.0(4)E-4	2.9(6)E-6
²⁰⁹ Bi	319.78(4)	0.0115(14)	1.67(20)E-4
²⁰⁹ Bi	347.92(9)	2.1(4)E-4	3.0(6)E-6
²⁰⁹ Bi	347.93(5)	1.8(8)E-4	2.6(12)E-6
²⁰⁹ Bi	392.82(9)	2.4(4)E-4	3.5(6)E-6
²⁰⁹ Bi	408.77(7)	0.00043(7)	6.2(10)E-6
²⁰⁹ Bi	563.06(7)	2.1(8)E-4	3.0(12)E-6
²⁰⁹ Bi	563.14(7)	0.00051(7)	7.4(10)E-6
²⁰⁹ Bi	610.92(11)	1.8(4)E-4	2.6(6)E-6
²⁰⁹ Bi	644.36(8)	2.5(4)E-4	3.6(6)E-6
²⁰⁹ Bi	645.82(6)	0.00047(7)	6.8(10)E-6

^A Z	E _γ -keV	σ _γ ^Z (E _γ)-barns	k ₀
²⁰⁹ Bi	673.97(5)	0.0026(4)	3.8(6)E-5
²⁰⁹ Bi	769.21(6)	0.00078(10)	1.13(15)E-5
²⁰⁹ Bi	774.91(10)	0.00054(21)	8(3)E-6
²⁰⁹ Bi	774.92(7)	0.00141(20)	2.0(3)E-5
²⁰⁹ Bi	808.77(7)	0.00042(16)	6.1(23)E-6
²⁰⁹ Bi	808.79(7)	0.00119(16)	1.73(23)E-5
²⁰⁹ Bi	826.98(13)	2.0(3)E-4	2.9(4)E-6
²⁰⁹ Bi	855.45(14)	1.8(4)E-4	2.6(6)E-6
²⁰⁹ Bi	900.07(7)	0.00035(13)	5.1(19)E-6
²⁰⁹ Bi	900.22(9)	0.00102(14)	1.48(20)E-5
²⁰⁹ Bi	912.77(10)	0.00034(5)	4.9(7)E-6
²⁰⁹ Bi	971.82(7)	0.00026(9)	3.8(13)E-6
²⁰⁹ Bi	971.83(9)	0.00072(9)	1.04(13)E-5
²⁰⁹ Bi	1012.53(7)	0.00064(9)	9.3(13)E-6
²⁰⁹ Bi	1013.03(13)	2.1(8)E-4	3.0(12)E-6
²⁰⁹ Bi	1118.21(19)	2.1(4)E-4	3.0(6)E-6
²⁰⁹ Bi	1156.34(14)	2.0(4)E-4	2.9(6)E-6
²⁰⁹ Bi	1175.48(12)	0.00048(7)	7.0(10)E-6
²⁰⁹ Bi	1203.52(11)	0.00077(12)	1.12(17)E-5
²⁰⁹ Bi	1203.61(8)	2.1(8)E-4	3.0(12)E-6
²⁰⁹ Bi	1203.61(10)	2.1(8)E-4	3.0(12)E-6
²⁰⁹ Bi	1211.11(15)	0.00031(5)	4.5(7)E-6
²⁰⁹ Bi	1226.30(6)	0.00042(7)	6.1(10)E-6
²⁰⁹ Bi	1337.09(6)	0.00156(21)	2.3(3)E-5
²⁰⁹ Bi	1360.16(15)	2.0(4)E-4	2.9(6)E-6
²⁰⁹ Bi	1397.83(11)	0.00033(5)	4.8(7)E-6
²⁰⁹ Bi	1430.29(14)	0.00027(4)	3.9(6)E-6
²⁰⁹ Bi	1465.52(14)	0.00026(4)	3.8(6)E-6
²⁰⁹ Bi	1484.30(8)	0.00034(5)	4.9(7)E-6
²⁰⁹ Bi	1596.43(7)	0.00073(10)	1.06(15)E-5
²⁰⁹ Bi	1625.78(17)	2.1(4)E-4	3.0(6)E-6
²⁰⁹ Bi	1658.34(7)	0.00035(5)	5.1(7)E-6
²⁰⁹ Bi	1708.84(9)	0.00071(10)	1.03(15)E-5
²⁰⁹ Bi	1708.92(10)	2.2(8)E-4	3.2(12)E-6
²⁰⁹ Bi	1756.35(14)	2.4(4)E-4	3.5(6)E-6
²⁰⁹ Bi	1824.97(15)	0.00054(8)	7.8(12)E-6
²⁰⁹ Bi	1839.74(13)	0.00046(7)	6.7(10)E-6
²⁰⁹ Bi	2026.66(15)	0.00037(7)	5.4(10)E-6
²⁰⁹ Bi	2496.69(16)	0.00034(7)	4.9(10)E-6
²⁰⁹ Bi	2505.35(7)	0.0021(3)	3.0(4)E-5
²⁰⁹ Bi	2570.29(7)	0.00031(5)	4.5(7)E-6
²⁰⁹ Bi	2598.33(8)	0.00166(24)	2.4(4)E-5
²⁰⁹ Bi	2614.55(12)	0.00027(5)	3.9(7)E-6
²⁰⁹ Bi	2624.34(7)	0.00154(21)	2.2(3)E-5
²⁰⁹ Bi	2828.29(7)	0.00179(24)	2.6(4)E-5
²⁰⁹ Bi	2898.17(8)	0.00080(12)	1.16(17)E-5
²⁰⁹ Bi	3081.27(10)	0.00145(20)	2.1(3)E-5
²⁰⁹ Bi	3141.75(8)	0.00041(7)	5.9(10)E-6
²⁰⁹ Bi	3214.64(8)	0.00061(9)	8.8(13)E-6
²⁰⁹ Bi	3230.66(10)	2.1(4)E-4	3.0(6)E-6
²⁰⁹ Bi	3268.99(9)	2.2(5)E-4	3.2(7)E-6
²⁰⁹ Bi	3356.60(8)	0.00167(24)	2.4(4)E-5
²⁰⁹ Bi	3396.16(7)	0.00170(24)	2.5(4)E-5
²⁰⁹ Bi	3407.4(3)	2.5(5)E-4	3.6(7)E-6
²⁰⁹ Bi	3610.84(6)	2.1(5)E-4	3.0(7)E-6
²⁰⁹ Bi	3632.77(7)	0.00136(20)	2.0(3)E-5
²⁰⁹ Bi	4054.57(6)	0.0137(18)	2.0(3)E-4
²⁰⁹ Bi	4101.76(6)	0.0089(12)	1.29(17)E-4
²⁰⁹ Bi	4165.36(5)	0.00173(24)	2.5(4)E-5
²⁰⁹ Bi	4171.05(9)	0.0171(22)	2.5(3)E-4
²⁰⁹ Bi	4256.65(5)	0.0024(3)	3.5(4)E-5
²⁰⁹ Bi	4284.80(6)	0.00042(7)	6.1(10)E-6
Thorium (Z=90), At.Wt.=232.0381(1), σ_γ^Z=7.35(3)			
²³² Th	39.92(13)	0.0029(4)	3.8(5)E-5
²³² Th	44.36(14)	0.0031(4)	4.0(5)E-5
²³² Th	53.71(12)	0.0139(10)	1.82(13)E-4
²³² Th	57.41(15)	0.0068(9)	8.9(12)E-5
²³² Th	63.810(10)	10.7(5) s⁻¹g⁻¹	Abundant

A_Z	E_γ -keV	$\sigma_\gamma^Z(E_\gamma)$ -barns	k_0	A_Z	E_γ -keV	$\sigma_\gamma^Z(E_\gamma)$ -barns	k_0
${}^{232}\text{Th}$	77.09(15)	0.09(3)	0.0012(4)	${}^{232}\text{Th}$	849.4(7)	0.005(3)	7(4)E-5
${}^{232}\text{Th}$	140.880(10)	0.85(18) s ⁻¹ g ⁻¹	Abundant	${}^{232}\text{Th}$	860.61(13)	0.047(5)	0.00061(7)
${}^{232}\text{Th}$	201.75(12)	0.0079(8)	1.03(10)E-4	${}^{232}\text{Th}$	869.69(14)	0.0138(11)	1.80(14)E-4
${}^{232}\text{Th}$	211.86(11)	0.0191(17)	2.49(22)E-4	${}^{232}\text{Th}$	872.13(11)	0.0268(15)	0.000350(20)
${}^{232}\text{Th}$	229.08(11)	0.0163(13)	2.13(17)E-4	${}^{232}\text{Th}$	907.44(14)	0.0081(10)	1.06(13)E-4
${}^{232}\text{Th}$	256.25(11)	0.093(17)	0.00121(22)	${}^{232}\text{Th}$	913.74(17)	0.0063(10)	8.2(13)E-5
${}^{232}\text{Th}$	263.06(14)	0.0073(17)	9.5(22)E-5	${}^{232}\text{Th}$	918.70(13)	0.0096(10)	1.25(13)E-4
${}^{232}\text{Th}$	277.48(11)	0.0312(25)	0.00041(3)	${}^{232}\text{Th}$	941.79(13)	0.0103(11)	1.35(14)E-4
${}^{232}\text{Th}$	281.40(11)	0.0170(14)	2.22(18)E-4	${}^{232}\text{Th}$	968.78(9)	0.132(6)	0.00172(8)
${}^{232}\text{Th}$	286.16(25)	0.0028(7)	3.7(9)E-5	${}^{232}\text{Th}$	996.7(3)	0.0067(16)	8.8(21)E-5
${}^{232}\text{Th}$	311.91(10)	0.0187(10)	2.44(13)E-4	${}^{232}\text{Th}$	1013.84(11)	0.037(3)	0.00048(4)
${}^{232}\text{Th}$	316.64(10)	0.0397(18)	0.000518(24)	${}^{232}\text{Th}$	1031.1(3)	0.0040(10)	5.2(13)E-5
${}^{232}\text{Th}$	319.08(10)	0.082(3)	0.00107(4)	${}^{232}\text{Th}$	1034.27(11)	0.0165(14)	2.15(18)E-4
${}^{232}\text{Th}$	320.98(13)	0.0072(8)	9.4(10)E-5	${}^{232}\text{Th}$	1044.58(14)	0.0112(12)	1.46(16)E-4
${}^{232}\text{Th}$	327.80(10)	0.0269(16)	0.000351(21)	${}^{232}\text{Th}$	1055.60(14)	0.0105(12)	1.37(16)E-4
${}^{232}\text{Th}$	329.88(11)	0.0221(17)	0.000289(22)	${}^{232}\text{Th}$	1096.9(4)	0.0050(13)	6.5(17)E-5
${}^{232}\text{Th}$	331.37(11)	0.0291(19)	0.000380(25)	${}^{232}\text{Th}$	1100.98(11)	0.0211(16)	0.000276(21)
${}^{232}\text{Th}$	335.92(10)	0.089(4)	0.00116(5)	${}^{232}\text{Th}$	1116.9(3)	0.0060(12)	7.8(16)E-5
${}^{232}\text{Th}$	354.27(10)	0.0408(20)	0.00053(3)	${}^{232}\text{Th}$	1125.46(19)	0.0079(13)	1.03(17)E-4
${}^{232}\text{Th}$	365.28(16)	0.0060(9)	7.8(12)E-5	${}^{232}\text{Th}$	1145.37(17)	0.0123(15)	1.61(20)E-4
${}^{232}\text{Th}$	366.79(16)	0.0061(9)	8.0(12)E-5	${}^{232}\text{Th}$	1152.1(4)	0.0052(15)	6.8(20)E-5
${}^{232}\text{Th}$	370.35(15)	0.0044(8)	5.7(10)E-5	${}^{232}\text{Th}$	1154.5(4)	0.0056(15)	7.3(20)E-5
${}^{232}\text{Th}$	384.7(3)	0.0030(8)	3.9(10)E-5	${}^{232}\text{Th}$	1164.6(4)	0.0047(13)	6.1(17)E-5
${}^{232}\text{Th}$	427.24(17)	0.0040(7)	5.2(9)E-5	${}^{232}\text{Th}$	1184.9(6)	0.0036(13)	4.7(17)E-5
${}^{232}\text{Th}$	432.15(13)	0.0076(8)	9.9(10)E-5	${}^{232}\text{Th}$	2485.2(3)	0.0090(17)	1.18(22)E-4
${}^{232}\text{Th}$	472.30(10)	0.165(8)	0.00215(10)	${}^{232}\text{Th}$	2503.5(3)	0.0107(18)	1.40(24)E-4
${}^{232}\text{Th}$	506.22(13)	0.0075(11)	9.8(14)E-5	${}^{232}\text{Th}$	2524.7(4)	0.0087(16)	1.14(21)E-4
${}^{232}\text{Th}$	522.73(10)	0.102(5)	0.00133(7)	${}^{232}\text{Th}$	2543.3(5)	0.013(3)	1.7(4)E-4
${}^{232}\text{Th}$	531.58(10)	0.0404(23)	0.00053(3)	${}^{232}\text{Th}$	2546.8(8)	0.0076(23)	1.0(3)E-4
${}^{232}\text{Th}$	535.08(17)	0.0062(11)	8.1(14)E-5	${}^{232}\text{Th}$	2551.9(4)	0.010(4)	1.3(5)E-4
${}^{232}\text{Th}$	539.66(10)	0.061(3)	0.00080(4)	${}^{232}\text{Th}$	2557.8(5)	0.0069(17)	9.0(22)E-5
${}^{232}\text{Th}$	548.23(11)	0.042(10)	0.00055(13)	${}^{232}\text{Th}$	2590.0(10)	0.0069(20)	9(3)E-5
${}^{232}\text{Th}$	553.36(13)	0.011(3)	1.4(4)E-4	${}^{232}\text{Th}$	2596.76(23)	0.0118(18)	1.54(24)E-4
${}^{232}\text{Th}$	556.93(11)	0.040(10)	0.00052(13)	${}^{232}\text{Th}$	2630.1(3)	0.0071(19)	9.3(25)E-5
${}^{232}\text{Th}$	561.25(11)	0.033(8)	0.00043(10)	${}^{232}\text{Th}$	2640.8(4)	0.0110(18)	1.44(24)E-4
${}^{232}\text{Th}$	566.63(10)	0.19(5)	0.0025(7)	${}^{232}\text{Th}$	2652.3(3)	0.010(4)	1.3(5)E-4
${}^{232}\text{Th}$	569.15(16)	0.008(3)	1.0(4)E-4	${}^{232}\text{Th}$	2659.39(21)	0.013(4)	1.7(5)E-4
${}^{232}\text{Th}$	578.02(9)	0.105(5)	0.00137(7)	${}^{232}\text{Th}$	2671.7(6)	0.0085(18)	1.11(24)E-4
${}^{232}\text{Th}$	580.16(19)	0.0125(21)	1.6(3)E-4	${}^{232}\text{Th}$	2689.4(8)	0.008(3)	1.0(4)E-4
${}^{232}\text{Th}$	583.27(9)	0.279(11)	0.00364(14)	${}^{232}\text{Th}$	2703.55(24)	0.014(5)	1.8(7)E-4
${}^{232}\text{Th}$	586.02(10)	0.045(3)	0.00059(4)	${}^{232}\text{Th}$	2712.56(22)	0.013(4)	1.7(5)E-4
${}^{232}\text{Th}$	593.23(10)	0.043(3)	0.00056(4)	${}^{232}\text{Th}$	2719.67(18)	0.016(3)	2.1(4)E-4
${}^{232}\text{Th}$	605.41(10)	0.054(4)	0.00071(5)	${}^{232}\text{Th}$	2732.7(5)	0.008(3)	1.0(4)E-4
${}^{232}\text{Th}$	612.45(9)	0.018(3)	2.4(4)E-4	${}^{232}\text{Th}$	2739.8(3)	0.0072(14)	9.4(18)E-5
${}^{232}\text{Th}$	622.95(11)	0.0125(15)	1.63(20)E-4	${}^{232}\text{Th}$	2744.7(3)	0.0081(15)	1.06(20)E-4
${}^{232}\text{Th}$	632.09(12)	0.0105(9)	1.37(12)E-4	${}^{232}\text{Th}$	2758.3(4)	0.0063(14)	8.2(18)E-5
${}^{232}\text{Th}$	659.56(16)	0.0173(20)	2.3(3)E-4	${}^{232}\text{Th}$	2771.3(4)	0.0030(12)	3.9(16)E-5
${}^{232}\text{Th}$	662.0(3)	0.0101(18)	1.32(24)E-4	${}^{232}\text{Th}$	2784.5(3)	0.0075(15)	9.8(20)E-5
${}^{232}\text{Th}$	665.11(10)	0.084(4)	0.00110(5)	${}^{232}\text{Th}$	2807.08(18)	0.0110(17)	1.44(22)E-4
${}^{232}\text{Th}$	681.81(9)	0.079(4)	0.00103(5)	${}^{232}\text{Th}$	2821.9(3)	0.0110(20)	1.4(3)E-4
${}^{232}\text{Th}$	684.96(13)	0.0117(16)	1.53(21)E-4	${}^{232}\text{Th}$	2824.9(3)	0.0144(22)	1.9(3)E-4
${}^{232}\text{Th}$	696.57(14)	0.0139(17)	1.82(22)E-4	${}^{232}\text{Th}$	2838.0(3)	0.0059(15)	7.7(20)E-5
${}^{232}\text{Th}$	703.1(5)	0.0073(18)	9.5(24)E-5	${}^{232}\text{Th}$	2851.0(3)	0.0077(15)	1.01(20)E-4
${}^{232}\text{Th}$	705.17(11)	0.050(4)	0.00065(5)	${}^{232}\text{Th}$	2880.86(17)	0.0093(14)	1.21(18)E-4
${}^{232}\text{Th}$	714.23(10)	0.052(3)	0.00068(4)	${}^{232}\text{Th}$	2924.3(3)	0.0082(11)	1.07(14)E-4
${}^{232}\text{Th}$	721.60(22)	0.0073(15)	9.5(20)E-5	${}^{232}\text{Th}$	2945.0(4)	0.0033(9)	4.3(12)E-5
${}^{232}\text{Th}$	735.25(14)	0.0123(16)	1.61(21)E-4	${}^{232}\text{Th}$	2970.49(21)	0.0064(10)	8.4(13)E-5
${}^{232}\text{Th}$	741.02(15)	0.0122(16)	1.59(21)E-4	${}^{232}\text{Th}$	2980.69(18)	0.0084(11)	1.10(14)E-4
${}^{232}\text{Th}$	752.05(16)	0.0142(19)	1.85(25)E-4	${}^{232}\text{Th}$	2989.93(25)	0.0066(10)	8.6(13)E-5
${}^{232}\text{Th}$	768.58(23)	0.0091(15)	1.19(20)E-4	${}^{232}\text{Th}$	3009.9(3)	0.0051(10)	6.7(13)E-5
${}^{232}\text{Th}$	777.8(4)	0.0034(14)	4.4(18)E-5	${}^{232}\text{Th}$	3044.7(4)	0.0031(12)	4.0(16)E-5
${}^{232}\text{Th}$	780.8(3)	0.0052(15)	6.8(20)E-5	${}^{232}\text{Th}$	3056.43(23)	0.0084(12)	1.10(16)E-4
${}^{232}\text{Th}$	785.86(22)	0.0097(18)	1.27(24)E-4	${}^{232}\text{Th}$	3070.6(4)	0.0039(12)	5.1(16)E-5
${}^{232}\text{Th}$	797.79(9)	0.0416(20)	0.00054(3)	${}^{232}\text{Th}$	3087.34(17)	0.0086(24)	1.1(3)E-4
${}^{232}\text{Th}$	808.53(11)	0.0212(14)	0.000277(18)	${}^{232}\text{Th}$	3118.4(9)	0.0040(10)	5.2(13)E-5
${}^{232}\text{Th}$	814.75(10)	0.0196(13)	0.000256(17)	${}^{232}\text{Th}$	3127.73(25)	0.0058(11)	7.6(14)E-5
${}^{232}\text{Th}$	834.83(14)	0.059(5)	0.00077(7)	${}^{232}\text{Th}$	3132.80(17)	0.0087(10)	1.14(13)E-4
${}^{232}\text{Th}$	846.0(5)	0.013(3)	1.7(4)E-4	${}^{232}\text{Th}$	3148.23(10)	0.0208(14)	0.000272(18)

^A Z	E _γ -keV	σ _γ ^Z (E _γ)-barns	k ₀
²³² Th	3173.87(19)	0.0089(10)	1.16(13)E-4
²³² Th	3184.94(17)	0.0079(10)	1.03(13)E-4
²³² Th	3196.66(12)	0.0171(13)	2.23(17)E-4
²³² Th	3230.47(23)	0.0123(12)	1.61(16)E-4
²³² Th	3245.2(5)	0.0030(8)	3.9(10)E-5
²³² Th	3260.9(3)	0.0056(9)	7.3(12)E-5
²³² Th	3276.3(4)	0.0063(10)	8.2(13)E-5
²³² Th	3287.94(14)	0.0165(14)	2.15(18)E-4
²³² Th	3294.9(3)	0.0051(9)	6.7(12)E-5
²³² Th	3326.21(17)	0.0102(10)	1.33(13)E-4
²³² Th	3341.90(13)	0.0168(13)	2.19(17)E-4
²³² Th	3363.3(3)	0.0051(8)	6.7(10)E-5
²³² Th	3377.84(13)	0.0135(12)	1.76(16)E-4
²³² Th	3391.3(3)	0.0044(8)	5.7(10)E-5
²³² Th	3398.09(13)	0.0191(14)	2.49(18)E-4
²³² Th	3436.17(12)	0.0211(15)	0.000276(20)
²³² Th	3448.42(10)	0.0233(16)	0.000304(21)
²³² Th	3461.45(24)	0.0069(10)	9.0(13)E-5
²³²Th	3473.00(8)	0.057(3)	0.00074(4)
²³² Th	3502.4(3)	0.0049(9)	6.4(12)E-5
²³² Th	3509.43(14)	0.0170(14)	2.22(18)E-4
²³² Th	3524.9(5)	0.0120(12)	1.57(16)E-4
²³²Th	3530.96(13)	0.0397(24)	0.00052(3)
²³² Th	3548.5(3)	0.0038(8)	5.0(10)E-5
²³² Th	3602.66(19)	0.0119(10)	1.55(13)E-4
²³² Th	3614.88(23)	0.0057(7)	7.4(9)E-5
²³² Th	3635.17(20)	0.0073(8)	9.5(10)E-5
²³² Th	3653.0(4)	0.0034(6)	4.4(8)E-5
²³² Th	3712.29(24)	0.0049(6)	6.4(8)E-5
²³² Th	3724.86(16)	0.0086(8)	1.12(10)E-4
²³² Th	3735.59(12)	0.0115(9)	1.50(12)E-4
²³² Th	3746.40(16)	0.0072(7)	9.4(9)E-5
²³² Th	3755.05(13)	0.0098(9)	1.28(12)E-4
²³² Th	3802.96(17)	0.0071(7)	9.3(9)E-5
²³² Th	3861.50(22)	0.0057(7)	7.4(9)E-5
²³² Th	3946.42(10)	0.0268(15)	0.000350(20)
²³² Th	3971.83(22)	0.0041(5)	5.4(7)E-5
²³² Th	4016.6(3)	0.0037(6)	4.8(8)E-5
²³² Th	4045.00(13)	0.0118(9)	1.54(12)E-4
²³² Th	4073.33(19)	0.0060(7)	7.8(9)E-5
²³² Th	4201.85(16)	0.0110(9)	1.44(12)E-4
²³² Th	4215.0(4)	0.0033(5)	4.3(7)E-5
²³² Th	4246.78(15)	0.0093(7)	1.21(9)E-4
²³² Th	4450.54(21)	0.0043(5)	5.6(7)E-5
²³² Th	4769.66(25)	0.0047(7)	6.1(9)E-5
²³² Th	4787.0(6)	0.0037(7)	4.8(9)E-5
Uranium (Z=92), At. Wt.=238.02891(3), σ_γ^Z=3.374(20)			
¹³⁹ Ba ^d	29.9660(10)d	0.0381(11)	0.000485[<0.1%]
²³⁵ U	31.60(5)	0.10(3) s ⁻¹ g ⁻¹	Abundant
²³⁵ U	34.70(10)	0.2100(15) s ⁻¹ g ⁻¹	Abundant
²³⁵ U	41.4(3)	0.17(12) s ⁻¹ g ⁻¹	Abundant
²³⁵ U	41.96(15)	0.35(6) s ⁻¹ g ⁻¹	Abundant
²³⁸ U	43.5330(10)d	0.110(3)	0.00140[53%]
²³⁵ U	51.22(10)	0.20(4) s ⁻¹ g ⁻¹	Abundant
²³⁵ U	54.25(5)	0.1700(12) s ⁻¹ g ⁻¹	Abundant
²³⁵ U	72.70(20)	0.630(5) s ⁻¹ g ⁻¹	Abundant
²³⁸ U	74.6640(10)d	1.300(3)	0.01655[53%]
²³⁵ U	75.02(5)	0.35(6) s ⁻¹ g ⁻¹	Abundant
²³⁵ U	76.198(4)	0.046(6) s ⁻¹ g ⁻¹	Abundant
²³⁵ U	96.090(20)	0.52(7) s ⁻¹ g ⁻¹	Abundant
²³⁸ Np ^d	106.1230(20)d	0.723(11)	0.00920[<0.1%]
²³⁵ U	109.160(20)	8.9(3) s ⁻¹ g ⁻¹	Abundant
²³⁵ U	115.45(5)	0.17(6) s ⁻¹ g ⁻¹	Abundant
²³⁵ U	120.35(5)	0.1500(11) s ⁻¹ g ⁻¹	Abundant
²³⁸ U	127.301(5)	0.0099(20)	1.26(25)E-4
²³⁸ U	133.7990(10)	0.38(8)	0.0048(10)
²³⁵ U	136.55(5)	0.0690(5) s ⁻¹ g ⁻¹	Abundant
²³⁵ U	140.76(4)	1.27(12) s ⁻¹ g ⁻¹	Abundant

^A Z	E _γ -keV	σ _γ ^Z (E _γ)-barns	k ₀
²³⁵ U	143.760(20)	63.0(7) s ⁻¹ g ⁻¹	Abundant
²³⁵ U	150.930(20)	0.46(6) s ⁻¹ g ⁻¹	Abundant
²³⁵ U	163.330(20)	29.2(3) s ⁻¹ g ⁻¹	Abundant
²³⁸ U	169.089(10)	0.012(4)	1.5(5)E-4
²³⁵ U	182.61(5)	1.96(12) s ⁻¹ g ⁻¹	Abundant
²³⁵ U	185.715(5)	329(4) s ⁻¹ g ⁻¹	Abundant
²³⁸ U	193.956(15)	0.0039(20)	5.0(25)E-5
²³⁵ U	194.940(10)	3.62(7) s ⁻¹ g ⁻¹	Abundant
²³⁵ U	198.900(20)	0.24(4) s ⁻¹ g ⁻¹	Abundant
²³⁵ U	202.110(20)	6.21(13) s ⁻¹ g ⁻¹	Abundant
²³⁵ U	205.311(10)	28.8(4) s ⁻¹ g ⁻¹	Abundant
²³⁸ Np ^d	209.7530(20)d	0.0909(13)	0.001157[<0.1%]
²³⁵ U	215.28(3)	0.167(17) s ⁻¹ g ⁻¹	Abundant
²³⁵ U	221.380(20)	0.69(6) s ⁻¹ g ⁻¹	Abundant
²³⁸ Np ^d	228.1830(10)d	0.286(5)	0.00364[<0.1%]
²³⁵ U	228.78(5)	0.0400(3) s ⁻¹ g ⁻¹	Abundant
²³⁵ U	233.50(3)	0.17(3) s ⁻¹ g ⁻¹	Abundant
²³⁵ U	240.87(3)	0.43(4) s ⁻¹ g ⁻¹	Abundant
²³⁵ U	243.60(20)	0.023(3)	0.00029(4)
²³⁵ U	246.84(4)	0.305(17) s ⁻¹ g ⁻¹	Abundant
²³⁸ U	250.062(7)	0.034(12)	0.00043(15)
²³⁵ U	275.129	0.30(3) s ⁻¹ g ⁻¹	Abundant
²³⁵ U	275.43(10)	0.040(12) s ⁻¹ g ⁻¹	Abundant
²³⁸ Np ^d	277.5990(10)d	0.382(6)	0.00486[<0.1%]
²³⁵ U	289.56(4)	0.0400(3) s ⁻¹ g ⁻¹	Abundant
²³⁵ U	291.65(3)	0.23(3) s ⁻¹ g ⁻¹	Abundant
²³⁸ U	292.5870(20)	0.016(6)	2.0(8)E-4
²³⁵ U ^f	297.00(10)	0.220(20)	0.00280(25)
²³⁵ U	300.00(10)	0.016(3)	2.0(4)E-4
²³⁸ Np ^d	315.880(3)d	0.0425(8)	0.000541[<0.1%]
²³⁸ Np ^d	334.3100(20)d	0.0550(8)	0.000700[<0.1%]
²³⁵ U	345.90(3)	0.23(3) s ⁻¹ g ⁻¹	Abundant
²³⁵ U	387.82(3)	0.23(3) s ⁻¹ g ⁻¹	Abundant
²³⁸ U	451.213(23)	0.010(4)	1.3(5)E-4
²³⁸ U	478.79(8)	0.012(4)	1.5(5)E-4
²³⁸ U	496.753(11)	0.034(8)	0.00043(10)
²³⁸ U	521.849(7)	0.073(3)	0.00093(4)
²³⁸ U	535.45(5)	0.028(6)	0.00036(8)
²³⁸ U	537.26(3)	0.0079(20)	1.01(25)E-4
¹³⁹ Ba ^d	537.261(9)d	0.066(3)	0.00084[<0.1%]
²³⁸ U	539.278(12)	0.099(20)	0.00126(25)
²³⁸ U	542.085(12)	0.024(6)	0.00031(8)
²³⁸ U	552.069(5)	0.207(5)	0.00264(6)
²³⁸ U	554.054(8)	0.085(20)	0.00108(25)
²³⁸ U	554.10(8)	0.028(6)	0.00036(8)
²³⁸ U	562.027(22)	0.032(10)	0.00041(13)
²³⁸ U	563.17(3)	0.014(4)	1.8(5)E-4
²³⁸ U	580.340(13)	0.043(10)	0.00055(13)
²³⁸ U	582.034(9)	0.016(4)	2.0(5)E-4
²³⁸ U	588.88(3)	0.024(6)	0.00031(8)
²³⁸ U	590.39(3)	0.034(12)	0.00043(15)
²³⁸ U	592.309(13)	0.045(12)	0.00057(15)
²³⁸ U	593.612(5)	0.108(24)	0.0014(3)
²³⁸ U	600.284(10)	0.030(8)	0.00038(10)
²³⁸ U	605.581(9)	0.053(12)	0.00067(15)
²³⁸ U	611.38(3)	0.014(4)	1.8(5)E-4
²³⁸ U	612.253(5)	0.23(5)	0.0029(6)
²³⁸ U	629.722(9)	0.073(20)	0.00093(25)
²³⁸ U	638.505(12)	0.041(12)	0.00052(15)
²³⁸ U	669.385(13)	0.0039(20)	5.0(25)E-5
²³⁸ U	673.307(12)	0.010(4)	1.3(5)E-4
²³⁸ U	681.355(9)	0.012(4)	1.5(5)E-4
²³⁸ U	687.853(8)	0.028(8)	0.00036(10)
²³⁸ U	689.907(11)	0.043(10)	0.00055(13)
²³⁸ U	715.832(9)	0.022(6)	0.00028(8)
²³⁸ U	767.86(21)	0.020(6)	0.00025(8)
²³⁸ U	787.15(7)	0.020(6)	0.00025(8)
²³⁸ U	794.21(8)	0.020(6)	0.00025(8)

^A Z	E _γ -keV	σ _γ ^z (E _γ)-barns	k ₀
²³⁸ U	799.12(7)	0.0079(20)	1.01(25)E-4
²³⁸ U	819.868(21)	0.010(4)	1.3(5)E-4
²³⁸ U	828.04(21)	0.024(6)	0.00031(8)
²³⁸ U	831.837(19)	0.053(12)	0.00067(15)
²³⁸ U	842.42(8)	0.024(6)	0.00031(8)
²³⁸ U	853.23(4)	0.055(12)	0.00070(15)
²³⁸ U	893.30(10)	0.016(4)	2.0(5)E-4
²³⁵ U	909.06(6)	0.026(4)	0.00033(5)
²³⁵ U	943.14(7)	0.082(10)	0.00104(13)
²³⁸ U	961.06(4)	0.0039(20)	5.0(25)E-5
²³⁸ U	990.49(3)	0.010(4)	1.3(5)E-4
²³⁸ U	1007.03(6)	0.0079(20)	1.01(25)E-4
²³⁸ U	1007.03(6)	0.0079(20)	1.01(25)E-4
²³⁵ U	1014.1(10)	0.026(4)	0.00033(5)
²³⁸ U	1021.25(4)	0.0079(20)	1.01(25)E-4
²³⁸ U	1021.25(4)	0.0079(20)	1.01(25)E-4
²³⁸ U	1029.32(5)	0.037(8)	0.00047(10)
²³⁸ U	1048.85(8)	0.012(4)	1.5(5)E-4
²³⁸ U	1060.82(8)	0.016(4)	2.0(5)E-4
²³⁸ U	1062.48(6)	0.0079(20)	1.01(25)E-4
²³⁸ U	1066.82(12)	0.030(6)	0.00038(8)
²³⁸ U	1089.50(5)	0.014(4)	1.8(5)E-4
²³⁸ U	1110.27(6)	0.010(4)	1.3(5)E-4
²³⁸ U	1149.8(3)	0.010(4)	1.3(5)E-4
²³⁸ U	1152.80(6)	0.010(4)	1.3(5)E-4
²³⁸ U	1155.05(4)	0.010(4)	1.3(5)E-4
²³⁸ U	1167.01(4)	0.020(6)	0.00025(8)
²³⁵ U ^f	1279.01(10)	0.200(10)	0.00255(13)
²³⁸ U	2998.5(5)	0.012(4)	1.5(5)E-4
²³⁸ U	3089.4(5)	0.0071(24)	9(3)E-5

^A Z	E _γ -keV	σ _γ ^z (E _γ)-barns	k ₀
²³⁸ U	3114.2(5)	0.007(3)	9(4)E-5
²³⁸ U	3121.7(5)	0.008(3)	1.0(4)E-4
²³⁸ U	3175.2(5)	0.0067(22)	9(3)E-5
²³⁸ U	3191.7(5)	0.0047(16)	6.0(20)E-5
²³⁸ U	3197.2(5)	0.016(6)	2.0(8)E-4
²³⁸ U	3220.1(5)	0.012(4)	1.5(5)E-4
²³⁸ U	3233.2(5)	0.010(3)	1.3(4)E-4
²³⁸ U	3286.12(20)	0.0040(3)	5.1(4)E-5
²³⁸ U	3296.5(3)	0.0070(5)	8.9(6)E-5
²³⁸ U	3312.8(5)	0.0040(10)	5.1(13)E-5
²³⁸ U	3445.44(6)	0.0045(3)	5.7(4)E-5
²³⁸ U	3564.45(9)	0.0042(4)	5.3(5)E-5
²³⁸ U	3583.10(7)	0.042(3)	0.00053(4)
²³⁸ U	3611.78(9)	0.0146(10)	1.86(13)E-4
²³⁸ U	3639.39(6)	0.0122(8)	1.55(10)E-4
²³⁸ U	3651.36(6)	0.0069(5)	8.8(6)E-5
²³⁸ U	3739.59(13)	0.0038(3)	4.8(4)E-5
²³⁸ U	3844.56(21)	0.0068(5)	8.7(6)E-5
²³⁸ U	3982.69(5)	0.0259(14)	0.000330(18)
²³⁸ U	3991.25(5)	0.0241(12)	0.000307(15)
²³⁸ U	4060.35(5)	0.186(3)	0.00237(4)
²³⁸ U	4067.02(5)	0.0073(4)	9.3(5)E-5

^d Fission or decay product

^f Prompt fission to ¹³⁴Te

“Abundant”: See explanation on page 78 in the text

Table 7.4 Energy-Ordered Table of Most Intense Thermal Neutron Capture Gamma Rays.

^A Z	E _γ -keV	σ _γ ^z (E _γ)-barns	k ₀	E _γ , σ _γ ^z (E _γ) for associated intense gamma rays
⁵⁶ Fe	14.411(14)	0.149(3)	0.00809(16)	7631.136(0.653), 7645.5450(0.549), 352.347(0.273)
⁷¹ Ga	16.43(3)	0.078(5)	0.00339(22)	834.08(1.65), 2201.91(0.52), 629.96(0.490)
⁵¹ V	17.152(6)	0.260(20)	0.0155(12)	1434.10(4.81), 125.082(1.61), 6517.282(0.78)
⁹³ Nb	17.810(7)	0.0579(14)	0.00189(5)	99.4070(0.196), 255.9290(0.176), 253.115(0.1320)
¹¹⁵ In	22.796(7)	7(3)	0.18(8)	1293.54(131), 1097.30(87.3), 416.86(43.0)
⁵⁵ Mn	26.560(20)	3.42(4)	0.1887(22)	846.754(13.10), 1810.72(3.62), 83.884(3.11)
¹²⁷ I	27.3620(10)	0.43(4)	0.0103(10)	133.6110(1.42), 442.901(0.600), 58.1100(0.28)
¹⁵⁹ Tb	29.0170(20)	0.21(4)	0.0040(8)	75.0500(1.78), 63.6860(1.46), 64.1100(1.2)
⁸¹ Br	29.1130(10)	0.1680(20)	0.00637(8)	776.517(0.990), 554.3480(0.838), 245.203(0.80)
³⁹ K	29.8300(10)	1.380(20)	0.1070(16)	770.3050(0.903), 1158.887(0.1600), 5380.018(0.146)
¹³⁹ La	29.9640(10)	0.169(8)	0.00369(17)	1596.21(5.84), 487.021(2.79), 815.772(1.430)
¹³⁹ Ba	29.9660(10)d	0.0381(11)	0.000485[0.1%]	74.6640(1.30000), 106.1230(0.723), 277.5990(0.382)
²⁷ Al	30.6380(10)	0.0798(20)	0.00896(22)	1778.92(0.232), 7724.027(0.0493), 3033.896(0.0179)
¹⁵⁹ Tb	32.652(3)	0.19(3)	0.0036(6)	75.0500(1.78), 63.6860(1.46), 64.1100(1.2)
¹⁵⁹ Tb	33.1590(10)	0.22(4)	0.0042(8)	75.0500(1.78), 63.6860(1.46), 64.1100(1.2)
⁷⁹ Br	37.0520(20)d	0.428(12)	0.0162[7.4%]	776.517(0.990), 554.3480(0.838), 245.203(0.80)
⁷⁹ Br	37.054(3)	0.160(10)	0.0061(4)	776.517(0.990), 554.3480(0.838), 245.203(0.80)
¹²³ Sb	40.8040(10)	0.10(3)	0.0025(8)	564.24(2.700), 61.4130(0.75), 78.0910(0.48)
¹⁷⁴ Yb	41.2180(20)	1.1(3)	0.019(5)	514.868(9.0), 639.261(1.43), 396.329(1.42)
¹⁵⁹ Tb	41.8900(10)	0.64(10)	0.0122(19)	75.0500(1.78), 63.6860(1.46), 64.1100(1.2)
²³⁸ U	43.5330(10)d	0.110(3)	0.00140[53%]	74.6640(1.30000), 106.1230(0.723), 277.5990(0.382)
⁷⁵ As	44.4250(10)	0.560(20)	0.0227(8)	559.10(2.00), 165.0490(0.996), 86.7880(0.579)
⁷⁵ As	46.0980(10)	0.337(15)	0.0136(6)	559.10(2.00), 165.0490(0.996), 86.7880(0.579)
¹⁸² W	46.4840(10)	0.192(10)	0.00316(16)	685.73(3.24), 479.550(2.59), 72.002(1.32)
¹⁷⁴ Yb	46.7510(20)	0.25(8)	0.0044(14)	514.868(9.0), 639.261(1.43), 396.329(1.42)
¹⁹¹ Ir	48.0570(10)	5.7(4)	0.090(6)	351.689(10.9), 328.448(9.1), 84.2740(7.7)
¹⁵¹ Eu	48.31(17)	181(70)	3.6(14)	89.847(1430), 77.23(187)
¹³³ Cs	48.790(20)	0.345(10)	0.00787(23)	176.4040(2.47), 205.615(1.560), 510.795(1.54)
¹⁶⁴ Dy	50.4310(20)	33.9(15)	0.63(3)	184.257(146), 538.609(69.2), 496.931(44.9)
¹⁵⁹ Tb	50.8690(10)	0.60(15)	0.011(3)	75.0500(1.78), 63.6860(1.46), 64.1100(1.2)
¹⁰³ Rh	51.50(3)	16.0(4)	0.471(12)	180.87(22.6), 97.14(19.5), 217.82(7.38)
¹⁰³ Rh	51.50(3)d	5.2(3)	0.153[90%]	180.87(22.6), 97.14(19.5), 51.50(16.0)
⁴⁵ Sc	52.0110(10)	0.87(3)	0.0586(20)	227.773(7.13), 147.011(6.08), 142.528(4.88)
¹²⁷ I	52.385(3)	0.167(19)	0.0040(5)	133.6110(1.42), 442.901(0.600), 27.3620(0.43)
¹⁸² W	52.5290(10)	0.128(11)	0.00211(18)	685.73(3.24), 479.550(2.59), 72.002(1.32)
¹⁵⁹ Tb	54.1290(10)	0.60(15)	0.011(3)	75.0500(1.78), 63.6860(1.46), 64.1100(1.2)
¹³⁹ La	54.9440(10)	0.143(7)	0.00312(15)	1596.21(5.84), 487.021(2.79), 815.772(1.430)
¹⁹⁷ Au	55.1810(10)	2.90(12)	0.0446(18)	410.(94.), 214.9710(9.0), 247.5730(5.56)
¹²⁷ I	58.1100(20)	0.28(4)	0.0067(10)	133.6110(1.42), 442.901(0.600), 27.3620(0.43)
¹⁹¹ Ir	58.8440(10)	5.3(3)	0.084(5)	351.689(10.9), 328.448(9.1), 84.2740(7.7)
¹⁸⁵ Re	59.0100(20)	5.5(8)	0.090(13)	63.5820(8.0), 155.041(7.16), 137.157(5.29)
¹⁸⁶ W	59.03(4)	0.208(7)	0.00343(12)	685.73(3.24), 479.550(2.59), 72.002(1.32)
⁷⁹ Br	59.471(4)	0.202(5)	0.00766(19)	776.517(0.990), 554.3480(0.838), 245.203(0.80)
¹⁵⁹ Tb	59.6430(10)	0.48(6)	0.0092(11)	75.0500(1.78), 63.6860(1.46), 64.1100(1.2)
⁸⁵ Rb	59.75(6)	0.010(4)	0.00035(14)	556.82(0.0913), 487.89(0.0494), 555.61(0.0407)
¹³³ Cs	60.0300(10)	0.443(14)	0.0101(3)	176.4040(2.47), 205.615(1.560), 510.795(1.54)
¹⁴¹ Pr	60.0630(20)	0.134(14)	0.0029(3)	176.8630(1.06), 140.9050(0.479), 1575.6(0.426)
¹¹⁵ In	60.9160(10)	15.8(11)	0.42(3)	1293.54(131), 1097.30(87.3), 416.86(43.0)
¹²¹ Sb	61.4130(10)	0.75(18)	0.019(5)	564.24(2.700), 78.0910(0.48), 121.4970(0.40)
¹⁷⁷ Hf	62.820(21)	5.26(16)	0.089(3)	213.439(29.3), 214.3410(16.3), 93.182(13.3)
¹³⁹ La	63.1790(10)	0.208(8)	0.00454(17)	1596.21(5.84), 487.021(2.79), 815.772(1.430)
¹⁸⁷ Re	63.5820(20)	8.0(14)	0.130(23)	155.041(7.16), 59.0100(5.5), 137.157(5.29)
¹⁵⁹ Tb	63.6860(10)	1.46(16)	0.028(3)	75.0500(1.78), 64.1100(1.2), 41.8900(0.64)
¹⁵⁹ Tb	64.1100(20)	1.2(3)	0.023(6)	75.0500(1.78), 63.6860(1.46), 41.8900(0.64)
¹⁴¹ Pr	64.5050(20)	0.137(6)	0.00295(13)	176.8630(1.06), 140.9050(0.479), 1575.6(0.426)
¹⁹¹ Ir	66.822(8)	1.31(13)	0.0207(20)	351.689(10.9), 328.448(9.1), 84.2740(7.7)
¹⁴¹ Pr	68.6110(20)	0.116(6)	0.00249(13)	176.8630(1.06), 140.9050(0.479), 1575.6(0.426)
¹⁶⁹ Tm	68.649	1.75(23)	0.031(4)	200.(8.72), 149.7180(7.11), 140.(5.96)
¹²¹ Sb	71.4670(10)	0.095(22)	0.0024(6)	564.24(2.700), 61.4130(0.75), 78.0910(0.48)
¹⁷⁵ Lu	71.5170(10)	3.96(22)	0.069(4)	150.392(13.8), 457.944(8.3), 138.607(6.79)
¹⁸⁶ W	72.002(4)d	1.32(3)	0.0218[1.4%]	685.73(3.24), 479.550(2.59), 134.247(1.050)
¹⁰⁹ Ag	72.67(5)	0.9(15)	0.03(4)	198.72(7.75), 235.62(4.62), 78.91(3.90)
²³⁸ U	74.6640(10)d	1.30000(14)	0.0165511[53%]	106.1230(0.723), 277.5990(0.382), 133.7990(0.38)
¹⁸⁷ Re	74.8630(20)	1.29(8)	0.0210(13)	63.5820(8.0), 155.041(7.16), 59.0100(5.5)
⁷⁵ As	74.8720(10)	0.12(3)	0.0049(12)	559.10(2.00), 165.0490(0.996), 86.7880(0.579)
¹⁵⁹ Tb	75.0500(10)	1.78(18)	0.034(3)	63.6860(1.46), 64.1100(1.2), 41.8900(0.64)

^A Z	E γ -keV	$\sigma_{\gamma}^z(E_{\gamma})$ -barns	k ₀	E γ , $\sigma_{\gamma}^z(E_{\gamma})$ for associated intense gamma rays
¹⁶⁹ Tm	75.83	0.94(8)	0.0169(14)	200.(8.72), 149.7180(7.11), 140.(5.96)
¹⁷³ Yb	76.996	0.40(4)	0.0070(7)	514.868(9.0), 639.261(1.43), 396.329(1.42)
²³² Th	77.09(15)	0.09(3)	0.0012(4)	583.27(0.279), 566.63(0.19), 472.30(0.165)
¹⁵¹ Eu	77.23(4)	187(13)	3.7(3)	89.847(1430), 48.31(181)
¹⁸⁶ W	77.39(3)	0.134(5)	0.00221(8)	685.73(3.24), 479.550(2.59), 72.002(1.32)
¹⁹¹ Ir	77.9470(10)	4.8(4)	0.076(6)	351.689(10.9), 328.448(9.1), 84.2740(7.7)
³¹ P	78.083(20)	0.059(3)	0.0058(3)	512.646(0.079), 636.663(0.0311), 3899.89(0.0294)
¹²¹ Sb	78.0910(10)	0.48(11)	0.012(3)	564.24(2.700), 61.4130(0.75), 121.4970(0.40)
¹⁷¹ Yb	78.7430(10)	0.67(10)	0.0117(18)	514.868(9.0), 639.261(1.43), 396.329(1.42)
¹⁵⁹ Tb	78.8670(10)	0.19(4)	0.0036(8)	75.0500(1.78), 63.6860(1.46), 64.1100(1.2)
¹⁰⁷ Ag	78.91(4)	3.90(12)	0.110(3)	198.72(7.75), 235.62(4.62), 117.45(3.85)
¹⁵⁹ Tb	79.099(6)	0.43(6)	0.0082(11)	75.0500(1.78), 63.6860(1.46), 64.1100(1.2)
¹⁵⁷ Gd	79.5100(10)	4010(100)	77.3(19)	181.931(7200), 944.174(3090), 962.104(2050)
¹⁶⁷ Er	79.8040(10)	18.2(8)	0.330(14)	184.2850(56), 815.9890(42.5), 198.2440(29.9)
¹⁰⁹ Ag	79.91(6)	1.0(16)	0.03(5)	198.72(7.75), 235.62(4.62), 78.91(3.90)
¹⁶⁵ Ho	80.574(8)d	3.87(5)	0.0711[1.3%]	136.6650(14.5), 116.8360(8.1), 426.012(2.88)
¹⁶¹ Dy	80.64(7)	16.5(5)	0.308(9)	184.257(146), 538.609(69.2), 496.931(44.9)
¹⁹⁷ Au	82.3560(10)	2.3(4)	0.035(6)	410.(94.), 214.9710(9.0), 247.5730(5.56)
¹⁹⁷ Au	82.5240(10)	1.4(3)	0.022(5)	410.(94.), 214.9710(9.0), 247.5730(5.56)
⁵⁵ Mn	83.884(23)	3.11(5)	0.172(3)	846.754(13.10), 1810.72(3.62), 26.560(3.42)
¹⁹¹ Ir	84.2740(20)	7.7(4)	0.121(6)	351.689(10.9), 328.448(9.1), 136.1250(6.5)
¹⁴¹ Pr	84.998(3)	0.207(11)	0.00445(24)	176.8630(1.06), 140.9050(0.479), 1575.6(0.426)
¹⁰³ Rh	85.19(3)	3.2(3)	0.094(9)	180.87(22.6), 97.14(19.5), 51.50(16.0)
¹¹⁵ In	85.5690(20)	22.1(16)	0.58(4)	1293.54(131), 1097.30(87.3), 416.86(43.0)
¹⁷³ Yb	86.11(7)	0.164(18)	0.0029(3)	514.868(9.0), 639.261(1.43), 396.329(1.42)
⁷⁵ As	86.7880(10)	0.579(11)	0.0234(4)	559.10(2.00), 165.0490(0.996), 44.4250(0.560)
¹⁸⁵ Re	87.264(3)	0.84(4)	0.0137(7)	63.5820(8.0), 155.041(7.16), 59.0100(5.5)
¹⁶⁹ Tm	87.5210(10)	1.29(3)	0.0231(5)	200.(8.72), 149.7180(7.11), 140.(5.96)
¹²³ Sb	87.601	0.212(8)	0.00528(20)	564.24(2.700), 61.4130(0.75), 78.0910(0.48)
¹⁷⁴ Yb	87.9690(20)	0.26(6)	0.0046(11)	514.868(9.0), 639.261(1.43), 396.329(1.42)
¹²¹ Sb	88.2690(10)	0.083(19)	0.0021(5)	564.24(2.700), 61.4130(0.75), 78.0910(0.48)
¹⁹¹ Ir	88.7340(10)	3.67(24)	0.058(4)	351.689(10.9), 328.448(9.1), 84.2740(7.7)
¹⁵⁵ Gd	88.9670(10)	1380(40)	26.6(8)	181.931(7200), 79.5100(4010), 944.174(3090)
⁶⁵ Cu	89.08(4)	0.0970(17)	0.00463(8)	278.250(0.893), 7915.62(0.869), 159.281(0.648)
¹⁵⁹ Tb	89.4080(20)	0.21(3)	0.0040(6)	75.0500(1.78), 63.6860(1.46), 64.1100(1.2)
¹⁵¹ Eu	89.847(6)	1430(30)	28.5(6)	77.23(187), 48.31(181)
¹⁹¹ Ir	90.7030(20)	1.25(15)	0.0197(24)	351.689(10.9), 328.448(9.1), 84.2740(7.7)
²³ Na	90.9920(10)	0.235(3)	0.0310(4)	1368.66(0.530), 2754.13(0.530), 472.202(0.478)
¹⁸⁷ Re	92.4640(20)	1.07(6)	0.0174(10)	63.5820(8.0), 155.041(7.16), 59.0100(5.5)
¹⁷⁷ Hf	93.182(6)	13.3(9)	0.226(15)	213.439(29.3), 214.3410(16.3), 325.559(6.69)
¹⁵⁹ Tb	93.3060(20)	0.218(25)	0.0042(5)	75.0500(1.78), 63.6860(1.46), 64.1100(1.2)
¹⁷⁴ Yb	95.2730(20)	0.20(5)	0.0035(9)	514.868(9.0), 639.261(1.43), 396.329(1.42)
¹¹⁵ In	96.036(5)	11.4(14)	0.30(4)	1293.54(131), 1097.30(87.3), 416.86(43.0)
¹¹⁵ In	96.062(3)	24.6(18)	0.65(5)	1293.54(131), 1097.30(87.3), 416.86(43.0)
¹⁰³ Rh	97.14(3)	19.5(4)	0.574(12)	180.87(22.6), 51.50(16.0), 217.82(7.38)
¹⁹⁷ Au	97.2500(20)	2.1(5)	0.032(8)	410.(94.), 214.9710(9.0), 247.5730(5.56)
¹⁵⁹ Tb	97.503(3)	0.50(6)	0.0095(11)	75.0500(1.78), 63.6860(1.46), 64.1100(1.2)
¹⁸² W	99.0790(10)	0.155(13)	0.00256(21)	685.73(3.24), 479.550(2.59), 72.002(1.32)
⁹³ Nb	99.4070(10)	0.196(9)	0.0064(3)	255.9290(0.176), 253.115(0.1320), 113.4010(0.117)
¹⁰³ Rh	100.74(4)	4.96(10)	0.146(3)	180.87(22.6), 97.14(19.5), 51.50(16.0)
¹⁹⁷ Au	101.9390(10)	0.953(17)	0.0147(3)	410.(94.), 214.9710(9.0), 247.5730(5.56)
¹⁷³ Yb	102.60(5)	0.44(5)	0.0077(9)	514.868(9.0), 639.261(1.43), 396.329(1.42)
⁷¹ Ga	103.25(3)d	0.0526(11)	0.00229[100%]	834.08(1.65), 2201.91(0.52), 629.96(0.490)
¹⁷⁴ Yb	104.5260(20)	0.43(11)	0.0075(19)	514.868(9.0), 639.261(1.43), 396.329(1.42)
⁵⁵ Mn	104.611(23)	1.74(3)	0.0960(17)	846.754(13.10), 1810.72(3.62), 26.560(3.42)
¹²¹ Sb	105.8160(10)	0.21(5)	0.0052(12)	564.24(2.700), 61.4130(0.75), 78.0910(0.48)
¹⁸⁷ Re	105.8620(20)	1.77(8)	0.0288(13)	63.5820(8.0), 155.041(7.16), 59.0100(5.5)
¹⁰⁹ Ag	105.95(6)	0.87(13)	0.024(4)	198.72(7.75), 235.62(4.62), 78.91(3.90)
²³⁸ Np	106.1230(20)d	0.723(11)	0.00920[0.6%]	74.6640(1.30000), 277.5990(0.382), 133.7990(0.38)
¹⁸² W	107.9320(10)	0.144(12)	0.00237(20)	685.73(3.24), 479.550(2.59), 72.002(1.32)
¹⁹¹ Ir	108.0300(20)	2.62(12)	0.0413(19)	351.689(10.9), 328.448(9.1), 84.2740(7.7)
¹⁸³ W	111.216(9)	0.195(6)	0.00321(10)	685.73(3.24), 479.550(2.59), 72.002(1.32)
¹⁹³ Ir	112.2310(10)	1.7(4)	0.027(6)	351.689(10.9), 328.448(9.1), 84.2740(7.7)
⁷¹ Ga	112.36(3)	0.155(3)	0.00674(13)	834.08(1.65), 2201.91(0.52), 629.96(0.490)
¹⁷⁶ Lu	112.9500(10)d	3.47(16)	0.060[0.2%]	150.392(13.8), 457.944(8.3), 138.607(6.79)
⁹³ Nb	113.4010(10)	0.117(3)	0.00382(10)	99.4070(0.196), 255.9290(0.176), 253.115(0.1320)
¹³³ Cs	113.7650(20)	0.777(15)	0.0177(3)	176.4040(2.47), 205.615(1.560), 510.795(1.54)
¹⁷⁴ Yb	113.805(4)d	0.417(14)	0.00730[0.3%]	514.868(9.0), 639.261(1.43), 396.329(1.42)
¹⁸¹ Ta	114.3150(10)	0.280(9)	0.00469(15)	270.4030(2.60), 173.2050(1.210), 402.623(1.180)

^A Z	E γ -keV	$\sigma_{\gamma}^Z(E_{\gamma})$ -barns	k ₀	E γ , $\sigma_{\gamma}^Z(E_{\gamma})$ for associated intense gamma rays
¹⁶⁹ Tm	114.544	3.19(6)	0.0572(11)	200.(8.72), 149.7180(7.11), 140.(5.96)
¹²¹ Sb	114.8680(10)	0.31(7)	0.0077(17)	564.24(2.700), 61.4130(0.75), 78.0910(0.48)
⁶⁴ Zn	115.225(18)	0.167(3)	0.00774(14)	1077.335(0.356), 7863.55(0.1410), 1883.12(0.0718)
¹³³ Cs	116.3740(20)	1.39(12)	0.032(3)	176.4040(2.47), 205.615(1.560), 510.795(1.54)
¹³³ Cs	116.612(4)	1.44(12)	0.033(3)	176.4040(2.47), 205.615(1.560), 510.795(1.54)
⁷⁵ As	116.7550(10)	0.107(18)	0.0043(7)	559.10(2.00), 165.0490(0.996), 86.7880(0.579)
¹⁶⁵ Ho	116.8360(10)	8.1(4)	0.149(7)	136.6650(14.5), 80.574(3.87), 426.012(2.88)
¹⁰⁹ Ag	117.45(8)	3.85(7)	0.1082(20)	198.72(7.75), 235.62(4.62), 78.91(3.90)
⁷⁵ As	120.2580(10)	0.402(8)	0.0163(3)	559.10(2.00), 165.0490(0.996), 86.7880(0.579)
¹³³ Cs	120.588(3)	0.414(10)	0.00944(23)	176.4040(2.47), 205.615(1.560), 510.795(1.54)
¹²¹ Sb	121.4970(10)	0.40(9)	0.0100(22)	564.24(2.700), 61.4130(0.75), 78.0910(0.48)
¹⁷⁶ Lu	121.620(3)	5.24(17)	0.091(3)	150.392(13.8), 457.944(8.3), 138.607(6.79)
⁵⁶ Fe	122.077(14)	0.096(3)	0.00521(16)	7631.136(0.653), 7645.5450(0.549), 352.347(0.273)
⁷⁵ As	122.2470(10)	0.227(5)	0.00918(20)	559.10(2.00), 165.0490(0.996), 86.7880(0.579)
¹²⁷ I	124.2810(20)	0.180(13)	0.0043(3)	133.6110(1.42), 442.901(0.600), 27.3620(0.43)
⁵¹ V	124.453(4)	0.23(5)	0.014(3)	1434.10(4.81), 125.082(1.61), 6517.282(0.78)
⁵¹ V	125.082(3)	1.61(4)	0.0958(24)	1434.10(4.81), 6517.282(0.78), 645.703(0.769)
¹¹⁵ In	126.3720(20)	4.0(3)	0.106(8)	1293.54(131), 1097.30(87.3), 416.86(43.0)
¹⁴¹ Pr	126.8460(20)	0.307(15)	0.0066(3)	176.8630(1.06), 140.9050(0.479), 1575.6(0.426)
¹⁹¹ Ir	126.958(3)	1.86(10)	0.0293(16)	351.689(10.9), 328.448(9.1), 84.2740(7.7)
¹⁰³ Rh	127.20(3)	5.27(21)	0.155(6)	180.87(22.6), 97.14(19.5), 51.50(16.0)
¹⁸⁶ W	127.43(4)	0.129(5)	0.00213(8)	685.73(3.24), 479.550(2.59), 72.002(1.32)
¹³³ Cs	127.5000(20)d	0.310(11)	7.1E-03[11%]	176.4040(2.47), 205.615(1.560), 510.795(1.54)
¹⁶⁹ Tm	130.027	0.940(25)	0.0169(5)	200.(8.72), 149.7180(7.11), 140.(5.96)
¹³³ Cs	130.2320(20)	1.410(21)	0.0322(5)	176.4040(2.47), 205.615(1.560), 510.795(1.54)
¹²⁷ I	133.6110(10)	1.42(10)	0.0339(24)	442.901(0.600), 27.3620(0.43), 58.1100(0.28)
²³⁸ U	133.7990(10)	0.38(8)	0.0048(10)	74.6640(1.30000), 106.1230(0.723), 277.5990(0.382)
¹⁸¹ Ta	133.8770(20)	0.63(7)	0.0106(12)	270.4030(2.60), 173.2050(1.210), 402.623(1.180)
¹⁸⁶ W	134.247(7)d	1.050(20)	0.0173[1.4%]	685.73(3.24), 479.550(2.59), 72.002(1.32)
¹⁰³ Rh	134.54(3)	6.8(4)	0.200(12)	180.87(22.6), 97.14(19.5), 51.50(16.0)
⁷⁵ As	135.4110(10)	0.156(4)	0.00631(16)	559.10(2.00), 165.0490(0.996), 86.7880(0.579)
¹⁵⁹ Tb	135.5970(20)	0.39(4)	0.0074(8)	75.0500(1.78), 63.6860(1.46), 64.1100(1.2)
¹⁹¹ Ir	136.1250(10)	6.5(9)	0.102(14)	351.689(10.9), 328.448(9.1), 84.2740(7.7)
¹⁹¹ Ir	136.213(3)	4.0(5)	0.063(8)	351.689(10.9), 328.448(9.1), 84.2740(7.7)
¹⁶⁵ Ho	136.6650(20)	14.5(7)	0.266(13)	116.8360(8.1), 80.574(3.87), 426.012(2.88)
¹⁹¹ Ir	136.7910(10)	2.20(21)	0.035(3)	351.689(10.9), 328.448(9.1), 84.2740(7.7)
¹⁸⁵ Re	137.157(8)d	5.29(3)	0.0861[0.4%]	63.5820(8.0), 155.041(7.16), 59.0100(5.5)
¹¹⁵ In	138.326(8)d	5.11(18)	0.135[30%]	1293.54(131), 1097.30(87.3), 416.86(43.0)
¹⁷⁶ Lu	138.607(5)	6.79(24)	0.118(4)	150.392(13.8), 457.944(8.3), 208.3660(6.0)
⁷⁶ Se	139.2270(10)	0.543(9)	0.0208(4)	613.724(2.14), 238.9980(2.06), 520.6370(1.260)
²⁰³ Tl	139.94(9)	0.400(7)	0.00593(10)	347.96(0.361), 318.88(0.325), 5641.57(0.316)
¹⁴¹ Pr	140.9050(20)	0.479(10)	0.01030(22)	176.8630(1.06), 1575.6(0.426), 5666.170(0.379)
¹⁸⁷ Re	141.760(4)	1.46(8)	0.0238(13)	63.5820(8.0), 155.041(7.16), 59.0100(5.5)
⁴⁵ Sc	142.528(8)d	4.88(7)	0.329[99%]	227.773(7.13), 147.011(6.08), 295.243(3.97)
¹⁸⁵ Re	144.152(5)	1.8(3)	0.029(5)	63.5820(8.0), 155.041(7.16), 59.0100(5.5)
¹⁶⁹ Tm	144.4790(10)	1.2(4)	0.022(7)	200.(8.72), 149.7180(7.11), 140.(5.96)
¹⁶⁹ Tm	144.48	5.96(11)	0.1069(20)	200.(8.72), 149.7180(7.11), 237.2390(5.52)
⁷⁵ As	144.5480(10)	0.1000(22)	0.00404(9)	559.10(2.00), 165.0490(0.996), 86.7880(0.579)
¹⁹¹ Ir	144.903(5)	3.1(4)	0.049(6)	351.689(10.9), 328.448(9.1), 84.2740(7.7)
⁷¹ Ga	145.14(3)	0.466(7)	0.0203(3)	834.08(1.65), 2201.91(0.52), 629.96(0.490)
¹⁸⁶ W	145.79(3)	0.970(21)	0.0160(4)	685.73(3.24), 479.550(2.59), 72.002(1.32)
¹⁷⁶ Lu	145.870(4)	1.52(9)	0.0263(16)	150.392(13.8), 457.944(8.3), 138.607(6.79)
⁴⁵ Sc	147.011(10)	6.08(9)	0.410(6)	227.773(7.13), 142.528(4.88), 295.243(3.97)
¹⁷⁶ Lu	147.165(5)	4.96(19)	0.086(3)	150.392(13.8), 457.944(8.3), 138.607(6.79)
¹⁷⁶ Lu	147.167(5)	3.7(7)	0.064(12)	150.392(13.8), 457.944(8.3), 138.607(6.79)
⁵¹ V	147.846(3)	0.253(6)	0.0151(4)	1434.10(4.81), 125.082(1.61), 6517.282(0.78)
¹²¹ Sb	148.238	0.26(6)	0.0065(15)	564.24(2.700), 61.4130(0.75), 78.0910(0.48)
¹⁹³ Ir	148.9340(10)	1.4(9)	0.022(14)	351.689(10.9), 328.448(9.1), 84.2740(7.7)
¹⁶⁵ Ho	149.309(3)	2.25(12)	0.0413(22)	136.6650(14.5), 116.8360(8.1), 80.574(3.87)
¹⁶⁹ Tm	149.7180(10)	7.11(12)	0.1275(22)	200.(8.72), 140.(5.96), 237.2390(5.52)
¹⁷⁶ Lu	150.392(3)	13.8(4)	0.239(7)	457.944(8.3), 138.607(6.79), 208.3660(6.0)
¹⁹¹ Ir	151.5640(20)	2.89(20)	0.046(3)	351.689(10.9), 328.448(9.1), 84.2740(7.7)
¹⁸⁵ Re	151.688(3)	1.15(7)	0.0187(11)	63.5820(8.0), 155.041(7.16), 59.0100(5.5)
¹²⁷ I	153.011(3)	0.209(14)	0.0050(3)	133.6110(1.42), 442.901(0.600), 27.3620(0.43)
¹⁵⁹ Tb	153.6870(20)	0.44(5)	0.0084(10)	75.0500(1.78), 63.6860(1.46), 64.1100(1.2)
²⁰³ Tl	154.01(9)	0.0926(17)	0.001373(25)	139.94(0.400), 347.96(0.361), 318.88(0.325)
¹⁸⁷ Re	155.041(4)d	7.16(25)	0.117[2.0%]	63.5820(8.0), 59.0100(5.5), 137.157(5.29)
¹⁸⁷ Os	155.10(4)	1.19(3)	0.0190(5)	186.7180(2.08), 557.978(0.84), 569.344(0.694)
¹²³ Sb	155.1780(10)	0.081(9)	0.00202(22)	564.24(2.700), 61.4130(0.75), 78.0910(0.48)

^A Z	E γ -keV	$\sigma_{\gamma}^z(E_{\gamma})$ -barns	k ₀	E γ , $\sigma_{\gamma}^z(E_{\gamma})$ for associated intense gamma rays
¹³⁹ La	155.560(5)	0.192(7)	0.00419(15)	1596.21(5.84), 487.021(2.79), 815.772(1.430)
¹⁹¹ Ir	156.654(3)	2.76(12)	0.0435(19)	351.689(10.9), 328.448(9.1), 84.2740(7.7)
⁷⁵ As	157.7450(10)	0.117(24)	0.0047(10)	559.10(2.00), 165.0490(0.996), 86.7880(0.579)
¹⁹⁷ Au	158.4360(10)	1.250(18)	0.0192(3)	410.(94.), 214.9710(9.0), 247.5730(5.56)
⁵⁹ Co	158.517(17)	1.200(15)	0.0617(8)	229.879(7.18), 277.161(6.77), 555.972(5.76)
¹¹⁶ Sn	158.65(6)	0.0145(3)	0.000370(8)	1293.591(0.1340), 1171.28(0.0879), 1229.64(0.0673)
⁶³ Cu	159.281(5)	0.648(10)	0.0309(5)	278.250(0.893), 7915.62(0.869), 7637.40(0.54)
¹²⁷ I	160.7570(10)	0.187(16)	0.0045(4)	133.6110(1.42), 442.901(0.600), 27.3620(0.43)
⁷⁶ Se	161.9220(10)d	0.855(23)	0.0328[99%]	613.724(2.14), 238.9980(2.06), 520.6370(1.260)
²⁰⁹ Bi	162.19(11)	0.008(3)	1.2E-04(4)	4171.05(0.0171), 4054.57(0.0137), 319.78(0.0115)
¹⁸² W	162.315(8)	0.187(5)	0.00308(8)	685.73(3.24), 479.550(2.59), 72.002(1.32)
¹¹⁵ In	162.393(3)d	15.8(8)	0.417[100%]	1293.54(131), 1097.30(87.3), 416.86(43.0)
¹⁷⁶ Lu	162.492(4)	5.32(17)	0.092(3)	150.392(13.8), 457.944(8.3), 138.607(6.79)
¹³⁹ La	162.659(3)	0.489(18)	0.0107(4)	1596.21(5.84), 487.021(2.79), 815.772(1.430)
⁷⁵ As	165.0490(10)	0.996(16)	0.0403(7)	559.10(2.00), 86.7880(0.579), 44.4250(0.560)
¹⁶⁹ Tm	165.735	3.29(6)	0.0590(11)	200.(8.72), 149.7180(7.11), 140.(5.96)
¹³⁸ Ba	165.8570(10)d	0.074(8)	0.00163[21%]	1435.77(0.308), 627.29(0.294), 818.514(0.212)
¹⁹ F	166.700(20)	0.000413(18)	6.6E-05(3)	1633.53(0.0096), 583.561(0.00356), 656.006(0.00197)
⁴⁰ Ar	167.30(20)	0.53(5)	0.040(4)	4745.3(0.36), 1186.8(0.34), 516.0(0.167)
¹⁸⁷ Re	167.327(3)	1.46(6)	0.0238(10)	63.5820(8.0), 155.041(7.16), 59.0100(5.5)
¹⁹⁷ Au	168.3340(10)	3.60(22)	0.055(3)	410.(94.), 214.9710(9.0), 247.5730(5.56)
¹⁰³ Rh	169.16(5)	2.88(19)	0.085(6)	180.87(22.6), 97.14(19.5), 51.50(16.0)
¹⁹¹ Ir	169.196(3)	3.05(13)	0.0481(20)	351.689(10.9), 328.448(9.1), 84.2740(7.7)
¹⁹⁷ Au	170.1030(10)	1.66(22)	0.026(3)	410.(94.), 214.9710(9.0), 247.5730(5.56)
¹¹⁵ In	171.059(5)	3.44(25)	0.091(7)	1293.54(131), 1097.30(87.3), 416.86(43.0)
¹⁷⁶ Lu	171.869(7)	1.74(6)	0.0301(10)	150.392(13.8), 457.944(8.3), 138.607(6.79)
¹⁸¹ Ta	173.2050(20)	1.210(25)	0.0203(4)	270.4030(2.60), 402.623(1.180), 133.8770(0.63)
¹¹⁵ In	173.886(6)	4.1(3)	0.108(8)	1293.54(131), 1097.30(87.3), 416.86(43.0)
¹³³ Cs	174.3040(20)	0.420(11)	0.00958(25)	176.4040(2.47), 205.615(1.560), 510.795(1.54)
⁷⁰ Ge	175.05(3)	0.164(4)	0.00684(17)	595.851(1.100), 867.899(0.553), 608.353(0.250)
¹⁷³ Yb	175.30(5)	0.58(6)	0.0102(11)	514.868(9.0), 639.261(1.43), 396.329(1.42)
¹³³ Cs	176.4040(20)	2.47(4)	0.0563(9)	205.615(1.560), 510.795(1.54), 307.015(1.45)
¹⁴¹ Pr	176.8630(20)	1.06(4)	0.0228(9)	140.9050(0.479), 1575.6(0.426), 5666.170(0.379)
¹⁰³ Rh	178.66(4)	3.27(14)	0.096(4)	180.87(22.6), 97.14(19.5), 51.50(16.0)
¹⁵⁹ Tb	178.881(3)	0.42(8)	0.0080(15)	75.0500(1.78), 63.6860(1.46), 64.1100(1.2)
¹⁹¹ Ir	179.0380(20)	2.1(5)	0.033(8)	351.689(10.9), 328.448(9.1), 84.2740(7.7)
¹⁰³ Rh	180.87(3)	22.6(15)	0.67(4)	97.14(19.5), 51.50(16.0), 217.82(7.38)
¹⁶⁹ Tm	180.993	3.85(14)	0.0691(25)	200.(8.72), 149.7180(7.11), 140.(5.96)
¹⁷¹ Yb	181.529(3)	0.53(6)	0.0093(11)	514.868(9.0), 639.261(1.43), 396.329(1.42)
¹⁵⁷ Gd	181.931(4)	7200(300)	139(6)	79.5100(4010), 944.174(3090), 962.104(2050)
¹⁴¹ Pr	182.786(4)	0.377(14)	0.0081(3)	176.8630(1.06), 140.9050(0.479), 1575.6(0.426)
⁷¹ Ga	184.09(3)	0.1040(21)	0.00452(9)	834.08(1.65), 2201.91(0.52), 629.96(0.490)
¹⁶⁴ Dy	184.257(4)	146(15)	2.7(3)	538.609(69.2), 496.931(44.9), 185.19(39.1)
¹⁶⁷ Er	184.2850(10)	56(5)	1.01(9)	815.9890(42.5), 198.2440(29.9), 79.8040(18.2)
¹⁶¹ Dy	185.19(9)	39.1(12)	0.729(22)	184.257(146), 538.609(69.2), 496.931(44.9)
¹⁷⁶ Lu	185.593(8)	3.42(12)	0.0592(21)	150.392(13.8), 457.944(8.3), 138.607(6.79)
⁶⁵ Cu	185.96(4)	0.244(3)	0.01164(14)	278.250(0.893), 7915.62(0.869), 159.281(0.648)
¹¹⁵ In	186.2100(20)	26.6(18)	0.70(5)	1293.54(131), 1097.30(87.3), 416.86(43.0)
¹⁸⁹ Os	186.7180(20)	2.08(5)	0.0331(8)	155.10(1.19), 557.978(0.84), 569.344(0.694)
¹³³ Cs	186.8400(20)	0.282(9)	0.00643(21)	176.4040(2.47), 205.615(1.560), 510.795(1.54)
⁶⁹ Ga	187.84(3)	0.1080(21)	0.00469(9)	834.08(1.65), 2201.91(0.52), 629.96(0.490)
¹⁷⁶ Lu	187.970(23)	1.39(6)	0.0241(10)	150.392(13.8), 457.944(8.3), 138.607(6.79)
¹⁸⁷ Re	188.813(6)	0.98(10)	0.0159(16)	63.5820(8.0), 155.041(7.16), 59.0100(5.5)
¹⁶⁸ Yb	191.2140(10)	0.22(4)	0.0039(7)	514.868(9.0), 639.261(1.43), 396.329(1.42)
¹⁰⁷ Ag	191.39(3)	1.81(5)	0.0509(14)	198.72(7.75), 235.62(4.62), 78.91(3.90)
⁷¹ Ga	192.11(3)	0.194(3)	0.00843(13)	834.08(1.65), 2201.91(0.52), 629.96(0.490)
¹⁹⁷ Au	192.3920(10)	3.9(18)	0.06(3)	410.(94.), 214.9710(9.0), 247.5730(5.56)
¹⁰⁷ Ag	192.90(3)	2.20(6)	0.0618(17)	198.72(7.75), 235.62(4.62), 78.91(3.90)
¹⁹⁷ Au	192.9440(10)	1.70(22)	0.026(3)	410.(94.), 214.9710(9.0), 247.5730(5.56)
¹⁵⁹ Tb	193.431(4)	0.37(4)	0.0071(8)	75.0500(1.78), 63.6860(1.46), 64.1100(1.2)
⁷¹ Ga	194.66(4)	0.1070(21)	0.00465(9)	834.08(1.65), 2201.91(0.52), 629.96(0.490)
⁷⁹ Br	195.602(4)	0.434(14)	0.0165(5)	776.517(0.990), 554.3480(0.838), 245.203(0.80)
⁸⁷ Rb	196.34(3)	0.00964(19)	0.000342(7)	556.82(0.0913), 487.89(0.0494), 555.61(0.0407)
⁷¹ Ga	197.94(5)	0.1330(24)	0.00578(10)	834.08(1.65), 2201.91(0.52), 629.96(0.490)
¹⁶⁷ Er	198.2440(10)	29.9(16)	0.54(3)	184.2850(56), 815.9890(42.5), 79.8040(18.2)
¹³³ Cs	198.3010(20)	1.100(19)	0.0251(4)	176.4040(2.47), 205.615(1.560), 510.795(1.54)
²⁰³ Tl	198.33(8)	0.0408(10)	0.000605(15)	139.94(0.400), 347.96(0.361), 318.88(0.325)
¹⁶⁹ Tm	198.5260(10)	0.96(3)	0.0172(5)	200.(8.72), 149.7180(7.11), 140.(5.96)
¹⁰⁹ Ag	198.72(4)	7.75(13)	0.218(4)	235.62(4.62), 78.91(3.90), 117.45(3.85)

^A Z	E γ -keV	$\sigma_{\gamma}^z(E_{\gamma})$ -barns	k ₀	E γ , $\sigma_{\gamma}^z(E_{\gamma})$ for associated intense gamma rays
¹⁵⁵ Gd	199.2130(10)	2020(60)	38.9(12)	181.931(7200), 79.5100(4010), 944.174(3090)
¹⁸⁵ Re	199.337(16)	0.91(4)	0.0148(7)	63.5820(8.0), 155.041(7.16), 59.0100(5.5)
¹⁸⁷ Re	199.513(5)	1.02(10)	0.0166(16)	63.5820(8.0), 155.041(7.16), 59.0100(5.5)
⁷⁶ Se	200.4530(20)	0.233(9)	0.0089(4)	613.724(2.14), 238.9980(2.06), 520.6370(1.260)
¹⁸⁶ W	201.44(5)	0.319(8)	0.00526(13)	685.73(3.24), 479.550(2.59), 72.002(1.32)
¹²¹ Sb	201.5950(10)	0.091(3)	0.00226(8)	564.24(2.700), 61.4130(0.75), 78.0910(0.48)
⁸⁹ Y	202.53(3)	0.289(7)	0.00985(24)	6080.171(0.76), 776.613(0.659), 574.106(0.174)
⁶³ Cu	202.950(8)	0.193(3)	0.00920(14)	278.250(0.893), 7915.62(0.869), 159.281(0.648)
¹⁶⁹ Tm	204.448	8.72(19)	0.156(3)	149.7180(7.11), 140.(5.96), 237.2390(5.52)
¹⁸⁶ W	204.83(4)	0.148(4)	0.00244(7)	685.73(3.24), 479.550(2.59), 72.002(1.32)
¹³³ Cs	205.615(3)	1.560(25)	0.0356(6)	176.4040(2.47), 510.795(1.54), 307.015(1.45)
¹⁹¹ Ir	206.220(4)	3.70(18)	0.058(3)	351.689(10.9), 328.448(9.1), 84.2740(7.7)
¹⁰⁷ Ag	206.46(3)	3.58(7)	0.1006(20)	198.72(7.75), 235.62(4.62), 78.91(3.90)
¹⁸⁷ Re	207.853(4)	4.44(21)	0.072(3)	63.5820(8.0), 155.041(7.16), 59.0100(5.5)
¹⁷⁶ Lu	208.3660(10)d	6.0(3)	0.104[0.2%]	150.392(13.8), 457.944(8.3), 138.607(6.79)
¹⁸⁷ Re	208.843(7)	0.98(10)	0.0159(16)	63.5820(8.0), 155.041(7.16), 59.0100(5.5)
²³⁸ Np	209.7530(20)d	0.0909(13)	0.001157[0.6%]	74.6640(1.30000), 106.1230(0.723), 277.5990(0.382)
¹⁹¹ Ir	210.354(5)	2.1(4)	0.033(6)	351.689(10.9), 328.448(9.1), 84.2740(7.7)
¹⁸⁵ Re	210.698(4)	1.50(10)	0.0244(16)	63.5820(8.0), 155.041(7.16), 59.0100(5.5)
⁷⁵ As	211.1470(10)	0.113(3)	0.00457(12)	559.10(2.00), 165.0490(0.996), 86.7880(0.579)
⁵⁵ Mn	212.039(21)	2.13(3)	0.1175(17)	846.754(13.10), 1810.72(3.62), 26.560(3.42)
⁷¹ Ga	212.58(4)	0.0583(12)	0.00253(5)	834.08(1.65), 2201.91(0.52), 629.96(0.490)
¹⁷⁷ Hf	213.439(7)	29.3(7)	0.497(12)	214.3410(16.3), 93.182(13.3), 325.559(6.69)
¹⁷⁸ Hf	214.3410(20)	5.7(6)	0.097(10)	213.439(29.3), 214.3410(16.3), 93.182(13.3)
¹⁷⁸ Hf	214.3410(20)d	16.3(3)	0.277[99%]	213.439(29.3), 93.182(13.3), 325.559(6.69)
¹⁸⁵ Re	214.647(4)	2.53(14)	0.0412(23)	63.5820(8.0), 155.041(7.16), 59.0100(5.5)
¹⁹⁷ Au	214.9710(10)	9.0(12)	0.138(18)	410.(94.), 247.5730(5.56), 261.4040(5.3)
¹⁰⁷ Ag	215.15(4)	1.55(3)	0.0435(8)	198.72(7.75), 235.62(4.62), 78.91(3.90)
¹⁰³ Rh	215.340(22)	5.20(12)	0.153(4)	180.87(22.6), 97.14(19.5), 51.50(16.0)
⁴⁵ Sc	216.44(4)	2.49(4)	0.168(3)	227.773(7.13), 147.011(6.08), 142.528(4.88)
¹⁰³ Rh	216.54(8)	5.0(10)	0.15(3)	180.87(22.6), 97.14(19.5), 51.50(16.0)
¹⁹¹ Ir	216.905(4)	5.57(24)	0.088(4)	351.689(10.9), 328.448(9.1), 84.2740(7.7)
¹⁰³ Rh	217.82(3)	7.38(13)	0.217(4)	180.87(22.6), 97.14(19.5), 51.50(16.0)
¹³⁹ La	218.225(22)	0.78(3)	0.0170(7)	1596.21(5.84), 487.021(2.79), 815.772(1.430)
¹³³ Cs	218.341(3)	0.309(9)	0.00705(21)	176.4040(2.47), 205.615(1.560), 510.795(1.54)
⁷⁹ Br	219.377(3)	0.399(14)	0.0151(5)	776.517(0.990), 554.3480(0.838), 245.203(0.80)
¹⁶⁹ Tm	219.706	3.64(6)	0.0653(11)	200.(8.72), 149.7180(7.11), 140.(5.96)
¹³³ Cs	219.7530(20)	0.344(9)	0.00784(21)	176.4040(2.47), 205.615(1.560), 510.795(1.54)
¹⁶⁵ Ho	221.186(4)	2.05(11)	0.0377(20)	136.6650(14.5), 116.8360(8.1), 80.574(3.87)
⁷⁹ Br	223.627(3)	0.153(5)	0.00580(19)	776.517(0.990), 554.3480(0.838), 245.203(0.80)
¹⁷⁵ Lu	225.4030(10)	1.73(8)	0.0300(14)	150.392(13.8), 457.944(8.3), 138.607(6.79)
¹⁸⁶ W	225.86(4)	0.113(17)	0.0019(3)	685.73(3.24), 479.550(2.59), 72.002(1.32)
¹⁹¹ Ir	226.2980(20)	4.0(4)	0.063(6)	351.689(10.9), 328.448(9.1), 84.2740(7.7)
¹⁸⁷ Re	227.083(6)	1.78(12)	0.0290(20)	63.5820(8.0), 155.041(7.16), 59.0100(5.5)
⁴⁵ Sc	227.773(12)	7.13(11)	0.481(7)	147.011(6.08), 142.528(4.88), 295.243(3.97)
²³⁸ Np	228.1830(10)d	0.286(5)	0.00364[0.6%]	74.6640(1.30000), 106.1230(0.723), 277.5990(0.382)
⁴⁵ Sc	228.716(12)	3.31(5)	0.223(3)	227.773(7.13), 147.011(6.08), 142.528(4.88)
⁵⁹ Co	229.879(17)	7.18(8)	0.369(4)	277.161(6.77), 555.972(5.76), 447.711(3.41)
¹²¹ Sb	233.1690(10)	0.0996(24)	0.00248(6)	564.24(2.700), 61.4130(0.75), 78.0910(0.48)
⁷⁹ Br	234.320(3)	0.205(10)	0.0078(4)	776.517(0.990), 554.3480(0.838), 245.203(0.80)
¹³³ Cs	234.3340(20)	1.070(23)	0.0244(5)	176.4040(2.47), 205.615(1.560), 510.795(1.54)
¹⁶⁹ Tm	235.1890(10)	1.18(4)	0.0212(7)	200.(8.72), 149.7180(7.11), 140.(5.96)
¹¹⁵ In	235.275(4)	4.9(3)	0.129(8)	1293.54(131), 1097.30(87.3), 416.86(43.0)
¹⁰⁹ Ag	235.62(4)	4.62(7)	0.1298(20)	198.72(7.75), 78.91(3.90), 117.45(3.85)
¹³⁹ La	235.771(8)	0.111(4)	0.00242(9)	1596.21(5.84), 487.021(2.79), 815.772(1.430)
⁷⁵ As	235.8770(10)	0.181(4)	0.00732(16)	559.10(2.00), 165.0490(0.996), 86.7880(0.579)
¹⁹⁷ Au	236.0450(10)	4.1(5)	0.063(8)	410.(94.), 214.9710(9.0), 247.5730(5.56)
¹⁸⁷ Re	236.627(4)	1.45(10)	0.0236(16)	63.5820(8.0), 155.041(7.16), 59.0100(5.5)
¹⁰⁷ Ag	236.85(4)	1.95(3)	0.0548(8)	198.72(7.75), 235.62(4.62), 78.91(3.90)
¹⁰⁹ Ag	236.89(7)	1.3(9)	0.037(25)	198.72(7.75), 235.62(4.62), 78.91(3.90)
¹⁶⁹ Tm	237.2390(10)	5.52(10)	0.0990(18)	200.(8.72), 149.7180(7.11), 140.(5.96)
¹³⁹ La	237.660(4)	0.320(12)	0.0070(3)	1596.21(5.84), 487.021(2.79), 815.772(1.430)
⁷⁶ Se	238.9980(10)	2.06(3)	0.0791(12)	613.724(2.14), 520.6370(1.260), 161.9220(0.855)
¹⁶⁵ Ho	239.132(4)	2.25(12)	0.0413(22)	136.6650(14.5), 116.8360(8.1), 80.574(3.87)
¹⁶⁹ Tm	242.6220(10)	1.28(4)	0.0230(7)	200.(8.72), 149.7180(7.11), 140.(5.96)
¹⁵⁹ Tb	242.973(12)	0.219(24)	0.0042(5)	75.0500(1.78), 63.6860(1.46), 64.1100(1.2)
⁷⁹ Br	244.237(3)	0.45(3)	0.0171(11)	776.517(0.990), 554.3480(0.838), 245.203(0.80)
⁸¹ Br	244.8310(10)	0.15(5)	0.0057(19)	776.517(0.990), 554.3480(0.838), 245.203(0.80)
⁷⁹ Br	245.203(4)	0.80(3)	0.0303(11)	776.517(0.990), 554.3480(0.838), 619.106(0.515)

A_Z	$E\gamma$ -keV	$\sigma\gamma^z(E\gamma)$ -barns	k_0	$E\gamma, \sigma\gamma^z(E\gamma)$ for associated intense gamma rays
¹¹⁰ Cd	245.3(3)	274(25)	7.4(7)	558.32(1860), 651.19(358)
¹³³ Cs	245.8620(20)	0.740(15)	0.0169(3)	176.4040(2.47), 205.615(1.560), 510.795(1.54)
¹⁹⁷ Au	247.5730(10)	5.56(8)	0.0855(12)	410.(94.), 214.9710(9.0), 261.4040(5.3)
¹⁵⁹ Tb	248.062(5)	0.30(3)	0.0057(6)	75.0500(1.78), 63.6860(1.46), 64.1100(1.2)
⁷¹ Ga	248.89(4)	0.136(8)	0.0059(4)	834.08(1.65), 2201.91(0.52), 629.96(0.490)
⁷⁶ Se	249.7880(10)	0.538(9)	0.0206(4)	613.724(2.14), 238.9980(2.06), 520.6370(1.260)
¹⁸⁷ Re	251.243(5)	1.80(23)	0.029(4)	63.5820(8.0), 155.041(7.16), 59.0100(5.5)
¹⁸³ W	252.854(11)	0.101(3)	0.00166(5)	685.73(3.24), 479.550(2.59), 72.002(1.32)
⁹³ Nb	253.115(5)	0.1320(19)	0.00431(6)	99.4070(0.196), 255.9290(0.176), 113.4010(0.117)
⁵⁹ Co	254.379(17)	1.290(16)	0.0663(8)	229.879(7.18), 277.161(6.77), 555.972(5.76)
¹⁸⁵ Re	254.998(4)	1.15(5)	0.0187(8)	63.5820(8.0), 155.041(7.16), 59.0100(5.5)
⁹³ Nb	255.9290(20)	0.176(3)	0.00574(10)	99.4070(0.196), 253.115(0.1320), 113.4010(0.117)
²³² Th	256.25(11)	0.093(17)	0.00121(22)	583.27(0.279), 566.63(0.19), 472.30(0.165)
¹⁸⁵ Re	257.447(9)	0.87(23)	0.014(4)	63.5820(8.0), 155.041(7.16), 59.0100(5.5)
¹⁰⁷ Ag	259.17(3)	1.560(25)	0.0438(7)	198.72(7.75), 235.62(4.62), 78.91(3.90)
¹⁷⁶ Lu	259.401(16)	1.89(8)	0.0327(14)	150.392(13.8), 457.944(8.3), 138.607(6.79)
¹³³ Cs	261.1640(20)	0.401(11)	0.00914(25)	176.4040(2.47), 205.615(1.560), 510.795(1.54)
¹⁹⁷ Au	261.4040(10)	5.3(20)	0.08(3)	410.(94.), 214.9710(9.0), 247.5730(5.56)
¹⁹¹ Ir	261.953(6)	2.02(23)	0.032(4)	351.689(10.9), 328.448(9.1), 84.2740(7.7)
¹⁹¹ Ir	262.03(10)	3.05(18)	0.048(3)	351.689(10.9), 328.448(9.1), 84.2740(7.7)
⁷⁵ As	263.8940(10)	0.18(4)	0.0073(16)	559.10(2.00), 165.0490(0.996), 86.7880(0.579)
¹⁰³ Rh	266.84(3)	2.66(17)	0.078(5)	180.87(22.6), 97.14(19.5), 51.50(16.0)
¹⁰⁹ Ag	267.08(3)	2.73(6)	0.0767(17)	198.72(7.75), 235.62(4.62), 78.91(3.90)
¹⁷⁶ Lu	268.788(5)	3.64(13)	0.0630(23)	150.392(13.8), 457.944(8.3), 138.607(6.79)
¹⁸¹ Ta	270.4030(20)	2.60(6)	0.0435(10)	173.2050(1.210), 402.623(1.180), 133.8770(0.63)
⁵⁵ Mn	271.198(22)	0.94(6)	0.052(3)	846.754(13.10), 1810.72(3.62), 26.560(3.42)
⁷⁹ Br	271.374(3)	0.462(7)	0.0175(3)	776.517(0.990), 554.3480(0.838), 245.203(0.80)
¹³⁹ La	272.306(4)	0.502(19)	0.0110(4)	1596.21(5.84), 487.021(2.79), 815.772(1.430)
¹⁸⁸ Os	272.82(4)	0.242(6)	0.00386(10)	186.7180(2.08), 155.10(1.19), 557.978(0.84)
¹¹⁵ In	272.9660(20)	33.1(24)	0.87(6)	1293.54(131), 1097.30(87.3), 416.86(43.0)
¹⁸⁶ W	273.10(5)	0.272(7)	0.00448(12)	685.73(3.24), 479.550(2.59), 72.002(1.32)
¹⁸⁷ Re	274.298(5)	0.80(6)	0.0130(10)	63.5820(8.0), 155.041(7.16), 59.0100(5.5)
⁷⁹ Br	274.532(5)	0.158(3)	0.00599(11)	776.517(0.990), 554.3480(0.838), 245.203(0.80)
⁵⁹ Co	277.161(17)	6.77(8)	0.348(4)	229.879(7.18), 555.972(5.76), 447.711(3.41)
²³² Th	277.48(11)	0.0312(25)	0.00041(3)	583.27(0.279), 566.63(0.19), 472.30(0.165)
²³⁸ Np	277.5990(10)d	0.382(6)	0.00486[0.6%]	74.6640(1.30000), 106.1230(0.723), 133.7990(0.38)
⁶³ Cu	278.250(14)	0.893(15)	0.0426(7)	7915.62(0.869), 159.281(0.648), 7637.40(0.54)
¹⁹³ Ir	278.5040(10)	1.8(11)	0.028(17)	351.689(10.9), 328.448(9.1), 84.2740(7.7)
¹⁷⁴ Yb	282.522(14)d	0.666(22)	0.0117[0.3%]	514.868(9.0), 639.261(1.43), 396.329(1.42)
¹²¹ Sb	282.6500(10)	0.274(7)	0.00682(17)	564.24(2.700), 61.4130(0.75), 78.0910(0.48)
⁶⁰ Ni	282.917(18)	0.211(3)	0.01089(15)	8998.414(1.49), 464.978(0.843), 8533.509(0.721)
¹³⁶ Ba	283.58(6)	0.0404(12)	0.00089(3)	1435.77(0.308), 627.29(0.294), 818.514(0.212)
¹⁹¹ Ir	284.074(6)	1.95(15)	0.0307(24)	351.689(10.9), 328.448(9.1), 84.2740(7.7)
¹⁶⁷ Er	284.6560(20)	13.7(12)	0.248(22)	184.2850(56), 815.9890(42.5), 198.2440(29.9)
¹¹⁵ In	284.914(4)	4.5(3)	0.119(8)	1293.54(131), 1097.30(87.3), 416.86(43.0)
⁷⁴ Se	286.5710(20)	0.280(6)	0.01075(23)	613.724(2.14), 238.9980(2.06), 520.6370(1.260)
⁸¹ Br	287.7390(20)	0.253(4)	0.00960(15)	776.517(0.990), 554.3480(0.838), 245.203(0.80)
¹³⁹ La	288.255(5)	0.73(3)	0.0159(7)	1596.21(5.84), 487.021(2.79), 815.772(1.430)
¹⁸⁷ Re	290.665(6)	3.5(4)	0.057(7)	63.5820(8.0), 155.041(7.16), 59.0100(5.5)
¹⁸⁷ Re	291.492(8)	0.94(7)	0.0153(11)	63.5820(8.0), 155.041(7.16), 59.0100(5.5)
¹⁹⁷ Au	291.7240(20)	1.05(17)	0.016(3)	410.(94.), 214.9710(9.0), 247.5730(5.56)
²⁰³ Tl	292.26(8)	0.0983(20)	0.00146(3)	139.94(0.400), 347.96(0.361), 318.88(0.325)
⁹³ Nb	293.206(4)	0.0651(16)	0.00212(5)	99.4070(0.196), 255.9290(0.176), 253.115(0.1320)
¹⁹³ Ir	293.541(14)d	1.76(6)	0.0277[1.8%]	351.689(10.9), 328.448(9.1), 84.2740(7.7)
⁷⁹ Br	294.349(3)	0.1160(22)	0.00440(8)	776.517(0.990), 554.3480(0.838), 245.203(0.80)
¹⁰⁷ Ag	294.39(3)	2.05(12)	0.058(3)	198.72(7.75), 235.62(4.62), 78.91(3.90)
⁵¹ V	295.023(14)	0.164(4)	0.00976(24)	1434.10(4.81), 125.082(1.61), 6517.282(0.78)
⁴⁵ Sc	295.243(10)	3.97(11)	0.268(7)	227.773(7.13), 147.011(6.08), 142.528(4.88)
²³⁵ U	297.00(10)	0.220(20)	0.00280(25)	74.6640(1.30000), 106.1230(0.723), 277.5990(0.382)
⁷⁶ Se	297.2160(20)	0.337(7)	0.0129(3)	613.724(2.14), 238.9980(2.06), 520.6370(1.260)
¹¹⁵ In	298.664(3)	9.4(7)	0.248(18)	1293.54(131), 1097.30(87.3), 416.86(43.0)
¹⁰⁷ Ag	299.95(3)	1.15(5)	0.0323(14)	198.72(7.75), 235.62(4.62), 78.91(3.90)
¹²⁷ I	301.906(5)	0.17(6)	0.0041(14)	133.6110(1.42), 442.901(0.600), 27.3620(0.43)
¹⁹¹ Ir	302.905(8)	1.20(11)	0.0189(17)	351.689(10.9), 328.448(9.1), 84.2740(7.7)
¹⁷⁸ Hf	303.9880(20)	3.38(9)	0.0574(15)	213.439(29.3), 214.3410(16.3), 93.182(13.3)
¹³³ Cs	307.015(4)	1.45(3)	0.0331(7)	176.4040(2.47), 205.615(1.560), 510.795(1.54)
⁹³ Nb	309.915(8)	0.0690(17)	0.00225(6)	99.4070(0.196), 255.9290(0.176), 253.115(0.1320)
¹⁷⁵ Lu	310.1870(10)	1.49(8)	0.0258(14)	150.392(13.8), 457.944(8.3), 138.607(6.79)
¹⁶⁹ Tm	311.0190(10)	2.50(5)	0.0448(9)	200.(8.72), 149.7180(7.11), 140.(5.96)

^A Z	E γ -keV	$\sigma_{\gamma}^z(E_{\gamma})$ -barns	k ₀	E γ , $\sigma_{\gamma}^z(E_{\gamma})$ for associated intense gamma rays
¹⁷⁴ Yb	311.276(5)	0.26(4)	0.0046(7)	514.868(9.0), 639.261(1.43), 396.329(1.42)
⁵⁵ Mn	314.398(20)	1.460(20)	0.0805(11)	846.754(13.10), 1810.72(3.62), 26.560(3.42)
⁷⁹ Br	314.982(3)	0.460(9)	0.0174(3)	776.517(0.990), 554.3480(0.838), 245.203(0.80)
²³⁸ Np	315.880(3)d	0.0425(8)	0.000541[0.6%]	74.6640(1.30000), 106.1230(0.723), 277.5990(0.382)
¹⁹¹ Ir	316.061(7)	2.4(4)	0.038(6)	351.689(10.9), 328.448(9.1), 84.2740(7.7)
¹⁸⁵ Re	316.457(9)	2.21(10)	0.0360(16)	63.5820(8.0), 155.041(7.16), 59.0100(5.5)
²³² Th	316.64(10)	0.0397(18)	0.000518(24)	583.27(0.279), 566.63(0.19), 472.30(0.165)
⁶⁹ Ga	318.87(3)	0.0592(14)	0.00257(6)	834.08(1.65), 2201.91(0.52), 629.96(0.490)
²⁰³ Tl	318.88(8)	0.325(6)	0.00482(9)	139.94(0.400), 347.96(0.361), 5641.57(0.316)
¹⁷⁶ Lu	319.036(8)	3.83(13)	0.0663(23)	150.392(13.8), 457.944(8.3), 138.607(6.79)
²³² Th	319.08(10)	0.082(3)	0.00107(4)	583.27(0.279), 566.63(0.19), 472.30(0.165)
²⁰⁹ Bi	319.78(4)	0.0115(14)	1.67E-04(20)	4171.05(0.0171), 4054.57(0.0137), 4101.76(0.0089)
¹⁸⁷ Os	322.98(6)	0.242(9)	0.00386(14)	186.7180(2.08), 155.10(1.19), 557.978(0.84)
¹⁷⁷ Hf	325.559(4)	6.69(17)	0.114(3)	213.439(29.3), 214.3410(16.3), 93.182(13.3)
¹⁹³ Ir	328.448(14)d	9.1(3)	0.143[1.8%]	351.689(10.9), 84.2740(7.7), 136.1250(6.5)
¹⁹⁷ Au	328.4840(20)	1.48(19)	0.023(3)	410.(94.), 214.9710(9.0), 247.5730(5.56)
¹³⁹ La	328.762(8)d	1.250(18)	0.0273[0.9%]	1596.21(5.84), 487.021(2.79), 815.772(1.430)
¹⁰⁷ Ag	328.99(3)	0.795(12)	0.0223(3)	198.72(7.75), 235.62(4.62), 78.91(3.90)
²³² Th	331.37(11)	0.0291(19)	0.000380(25)	583.27(0.279), 566.63(0.19), 472.30(0.165)
¹²¹ Sb	332.2860(10)	0.101(3)	0.00251(8)	564.24(2.700), 61.4130(0.75), 78.0910(0.48)
¹⁹⁵ Pt	332.985(4)	2.580(25)	0.0401(4)	355.6840(6.17)
¹⁰³ Rh	333.44(3)	3.27(8)	0.0963(24)	180.87(22.6), 97.14(19.5), 51.50(16.0)
¹⁹¹ Ir	333.864(6)	1.53(10)	0.0241(16)	351.689(10.9), 328.448(9.1), 84.2740(7.7)
¹⁴⁹ Sm	333.97(4)	4790(60)	96.5(12)	439.40(2860), 737.44(597), 505.51(528)
²³⁸ Np	334.3100(20)d	0.0550(8)	0.000700[0.6%]	74.6640(1.30000), 106.1230(0.723), 277.5990(0.382)
¹¹⁵ In	335.450(10)	9.1(7)	0.240(18)	1293.54(131), 1097.30(87.3), 416.86(43.0)
²³² Th	335.92(10)	0.089(4)	0.00116(5)	583.27(0.279), 566.63(0.19), 472.30(0.165)
⁹³ Nb	337.527(7)	0.054(6)	0.00176(20)	99.4070(0.196), 255.9290(0.176), 253.115(0.1320)
⁵⁸ Ni	339.420(11)	0.1670(21)	0.00862(11)	8998.414(1.49), 464.978(0.843), 8533.509(0.721)
¹⁵⁹ Tb	339.487(5)	0.35(4)	0.0067(8)	75.0500(1.78), 63.6860(1.46), 64.1100(1.2)
⁴⁸ Ti	341.706(5)	1.840(21)	0.1165(13)	1381.745(5.18), 6760.084(2.97), 6418.426(1.96)
⁷⁹ Br	343.405(3)	0.118(4)	0.00448(15)	776.517(0.990), 554.3480(0.838), 245.203(0.80)
⁶³ Cu	343.898(14)	0.215(4)	0.01025(19)	278.250(0.893), 7915.62(0.869), 159.281(0.648)
⁸¹ Br	345.0060(10)	0.154(4)	0.00584(15)	776.517(0.990), 554.3480(0.838), 245.203(0.80)
²⁰³ Tl	347.96(8)	0.361(10)	0.00535(15)	139.94(0.400), 318.88(0.325), 5641.57(0.316)
¹⁶⁴ Dy	349.248(10)	14.7(6)	0.274(11)	184.257(146), 538.609(69.2), 496.931(44.9)
²⁰ Ne	350.72(6)	0.0198(4)	0.00297(6)	2035.67(0.0245), 4374.13(0.01910), 2793.94(0.00900)
¹⁹⁷ Au	350.8280(10)	1.0(5)	0.015(8)	410.(94.), 214.9710(9.0), 247.5730(5.56)
¹⁹¹ Ir	351.689(4)	10.9(4)	0.172(6)	328.448(9.1), 84.2740(7.7), 136.1250(6.5)
⁵⁶ Fe	352.347(12)	0.273(3)	0.01481(16)	7631.136(0.653), 7645.5450(0.549), 6018.532(0.227)
²³² Th	354.27(10)	0.0408(20)	0.00053(3)	583.27(0.279), 566.63(0.19), 472.30(0.165)
¹⁹⁵ Pt	355.6840(20)	6.17(6)	0.0958(9)	332.985(2.580)
¹³³ Cs	356.157(4)	0.445(12)	0.0101(3)	176.4040(2.47), 205.615(1.560), 510.795(1.54)
¹⁵⁹ Tb	357.748(5)	0.26(3)	0.0050(6)	75.0500(1.78), 63.6860(1.46), 64.1100(1.2)
¹⁰⁹ Ag	360.41(3)	1.55(3)	0.0435(8)	198.72(7.75), 235.62(4.62), 78.91(3.90)
¹⁸⁹ Os	361.137(6)	0.466(15)	0.00742(24)	186.7180(2.08), 155.10(1.19), 557.978(0.84)
¹⁷⁴ Yb	363.938(6)	0.80(12)	0.0140(21)	514.868(9.0), 639.261(1.43), 396.329(1.42)
¹⁹¹ Ir	365.440(7)	1.15(10)	0.0181(16)	351.689(10.9), 328.448(9.1), 84.2740(7.7)
⁷⁹ Br	366.604(4)	0.233(6)	0.00884(23)	776.517(0.990), 554.3480(0.838), 245.203(0.80)
¹⁷⁶ Lu	367.433(11)	2.23(8)	0.0386(14)	150.392(13.8), 457.944(8.3), 138.607(6.79)
¹⁹⁹ Hg	367.947(9)	251(5)	3.79(8)	5967.02(62.5), 1693.296(56.2), 4739.43(30.1)
¹⁸⁹ Os	371.261(5)	0.574(14)	0.00914(22)	186.7180(2.08), 155.10(1.19), 557.978(0.84)
¹⁹³ Ir	371.5020(20)	2.11(12)	0.0333(19)	351.689(10.9), 328.448(9.1), 84.2740(7.7)
¹⁶⁵ Ho	371.772(5)	1.56(8)	0.0287(15)	136.6650(14.5), 116.8360(8.1), 80.574(3.87)
¹³³ Cs	377.311(5)	0.310(9)	0.00707(21)	176.4040(2.47), 205.615(1.560), 510.795(1.54)
¹⁰⁷ Ag	380.90(3)	1.59(3)	0.0447(8)	198.72(7.75), 235.62(4.62), 78.91(3.90)
¹⁹⁷ Au	381.1990(10)	3.0(4)	0.046(6)	410.(94.), 214.9710(9.0), 247.5730(5.56)
¹⁶⁹ Tm	384.0790(20)	1.95(5)	0.0350(9)	200.(8.72), 149.7180(7.11), 140.(5.96)
¹¹⁵ In	385.111(8)	12.1(9)	0.319(24)	1293.54(131), 1097.30(87.3), 416.86(43.0)
⁶⁵ Cu	385.77(3)	0.1310(18)	0.00625(9)	278.250(0.893), 7915.62(0.869), 159.281(0.648)
¹⁶⁴ Dy	385.9840(20)	34.8(10)	0.649(19)	184.257(146), 538.609(69.2), 496.931(44.9)
²⁴ Mg	389.670(21)	0.00586(24)	0.00073(3)	3916.84(0.0320), 585.00(0.0314), 2828.172(0.0240)
⁷¹ Ga	390.66(4)	0.0476(12)	0.00207(5)	834.08(1.65), 2201.91(0.52), 629.96(0.490)
¹⁸⁵ Re	390.854(23)	1.15(5)	0.0187(8)	63.5820(8.0), 155.041(7.16), 59.0100(5.5)
⁵⁹ Co	391.218(15)	1.080(14)	0.0555(7)	229.879(7.18), 277.161(6.77), 555.972(5.76)
⁷¹ Ga	393.28(3)	0.1340(23)	0.00582(10)	834.08(1.65), 2201.91(0.52), 629.96(0.490)
²⁰³ Tl	395.62(8)	0.0862(20)	0.00128(3)	139.94(0.400), 347.96(0.361), 318.88(0.325)
¹⁷⁴ Yb	396.329(20)d	1.42(5)	0.0249[0.3%]	514.868(9.0), 639.261(1.43), 5266.3(1.4)
¹⁸¹ Ta	402.623(3)	1.180(23)	0.0198(4)	270.4030(2.60), 173.2050(1.210), 133.8770(0.63)

^A Z	E _γ -keV	σ _γ ^Z (E _γ)-barns	k ₀	E _γ , σ _γ ^Z (E _γ) for associated intense gamma rays
¹⁶⁹ Tm	411.5060(20)	2.37(5)	0.0425(9)	200.(8.72), 149.7180(7.11), 140.(5.96)
¹⁶⁴ Dy	411.651(5)	35.1(10)	0.655(19)	184.257(146), 538.609(69.2), 496.931(44.9)
¹⁹⁷ Au	411.802d	94.29(15)	1.453[0.5%]	214.9710(9.0), 247.5730(5.56), 261.4040(5.3)
¹⁶⁴ Dy	414.985(7)	31(5)	0.58(9)	184.257(146), 538.609(69.2), 496.931(44.9)
¹¹⁵ In	416.86(3)d	43.0(18)	1.13[30%]	1293.54(131), 1097.30(87.3), 272.9660(33.1)
¹⁹¹ Ir	418.138(6)	3.45(15)	0.0544(24)	351.689(10.9), 328.448(9.1), 84.2740(7.7)
⁵¹ V	419.475(13)	0.249(6)	0.0148(4)	1434.10(4.81), 125.082(1.61), 6517.282(0.78)
⁸⁵ Rb	421.50(3)	0.0259(5)	0.000918(18)	556.82(0.0913), 487.89(0.0494), 555.61(0.0407)
¹³⁹ La	422.66(4)	0.370(14)	0.0081(3)	1596.21(5.84), 487.021(2.79), 815.772(1.430)
²⁰³ Tl	424.81(8)	0.1200(25)	0.00178(4)	139.94(0.400), 347.96(0.361), 318.88(0.325)
⁸³ Kr	425.30(11)	2.960(19)	0.1070(7)	881.74(20.8), 1213.42(8.28), 1463.86(7.10)
¹⁶⁵ Ho	426.012(5)	2.88(15)	0.053(3)	136.6650(14.5), 116.8360(8.1), 80.574(3.87)
⁷⁵ As	426.5750(10)	0.100(3)	0.00404(12)	559.10(2.00), 165.0490(0.996), 86.7880(0.579)
¹⁷⁴ Yb	428.613(12)	0.61(7)	0.0107(12)	514.868(9.0), 639.261(1.43), 396.329(1.42)
¹³⁹ La	432.493(12)d	0.1780(18)	0.00388[0.9%]	1596.21(5.84), 487.021(2.79), 815.772(1.430)
¹⁹¹ Ir	432.716(6)	1.85(7)	0.0292(11)	351.689(10.9), 328.448(9.1), 84.2740(7.7)
¹¹⁵ In	433.723(8)	6.0(4)	0.158(11)	1293.54(131), 1097.30(87.3), 416.86(43.0)
⁵⁹ Co	435.677(17)	0.789(10)	0.0406(5)	229.879(7.18), 277.161(6.77), 555.972(5.76)
¹⁷⁴ Yb	436.173(5)	0.52(6)	0.0091(11)	514.868(9.0), 639.261(1.43), 396.329(1.42)
⁵¹ V	436.627(13)	0.397(9)	0.0236(5)	1434.10(4.81), 125.082(1.61), 6517.282(0.78)
¹⁴⁹ Sm	439.40(4)	2860(150)	58(3)	333.97(4790), 737.44(597), 505.51(528)
⁷⁶ Se	439.4510(20)	0.319(8)	0.0122(3)	613.724(2.14), 238.9980(2.06), 520.6370(1.260)
¹³³ Cs	442.8430(20)	0.316(12)	0.0072(3)	176.4040(2.47), 205.615(1.560), 510.795(1.54)
¹²⁷ I	442.901(10)d	0.595(4)	0.0142[51%]	133.6110(1.42), 27.3620(0.43), 58.1100(0.28)
¹⁶⁹ Tm	446.328(3)	1.62(4)	0.0291(7)	200.(8.72), 149.7180(7.11), 140.(5.96)
⁵⁹ Co	447.711(19)	3.41(4)	0.1754(21)	229.879(7.18), 277.161(6.77), 555.972(5.76)
¹⁶⁴ Dy	447.893(7)	17.4(5)	0.324(9)	184.257(146), 538.609(69.2), 496.931(44.9)
¹³³ Cs	450.345(3)	0.99(5)	0.0226(11)	176.4040(2.47), 205.615(1.560), 510.795(1.54)
¹⁵⁹ Tb	451.617(10)	0.21(3)	0.0040(6)	75.0500(1.78), 63.6860(1.46), 64.1100(1.2)
⁵⁵ Mn	454.378(21)	0.388(7)	0.0214(4)	846.754(13.10), 1810.72(3.62), 26.560(3.42)
¹³⁸ Ba	454.73(5)	0.0853(22)	0.00188(5)	1435.77(0.308), 627.29(0.294), 818.514(0.212)
¹⁶⁹ Tm	456.0460(10)	1.16(4)	0.0208(7)	200.(8.72), 149.7180(7.11), 140.(5.96)
¹⁷⁶ Lu	457.944(15)	8.3(3)	0.144(5)	150.392(13.8), 138.607(6.79), 208.3660(6.0)
⁹³ Nb	458.467(10)	0.0240(5)	0.000783(16)	99.4070(0.196), 255.9290(0.176), 253.115(0.1320)
¹³⁷ Ba	462.78(4)	0.0660(16)	0.00146(4)	1435.77(0.308), 627.29(0.294), 818.514(0.212)
¹⁵⁹ Tb	464.264(17)	0.192(21)	0.0037(4)	75.0500(1.78), 63.6860(1.46), 64.1100(1.2)
⁵⁸ Ni	464.978(12)	0.843(10)	0.0435(5)	8998.414(1.49), 8533.509(0.721), 6837.50(0.458)
⁶⁵ Cu	465.14(3)	0.1350(21)	0.00644(10)	278.250(0.893), 7915.62(0.869), 159.281(0.648)
¹⁶⁴ Dy	465.416(6)	38.0(10)	0.709(19)	184.257(146), 538.609(69.2), 496.931(44.9)
⁷⁹ Br	468.980(3)	0.29(3)	0.0110(11)	776.517(0.990), 554.3480(0.838), 245.203(0.80)
¹⁰³ Rh	470.40(3)	2.61(7)	0.0769(21)	180.87(22.6), 97.14(19.5), 51.50(16.0)
⁷⁵ As	471.0000(10)	0.203(5)	0.00821(20)	559.10(2.00), 165.0490(0.996), 86.7880(0.579)
¹¹⁵ In	471.349(11)	4.3(3)	0.113(8)	1293.54(131), 1097.30(87.3), 416.86(43.0)
²⁰³ Tl	471.90(8)	0.116(3)	0.00172(4)	139.94(0.400), 347.96(0.361), 318.88(0.325)
²³ Na	472.202(9)d	0.478(4)	0.0630[100%]	1368.66(0.530), 2754.13(0.530), 90.9920(0.235)
²³² Th	472.30(10)	0.165(8)	0.00215(10)	583.27(0.279), 566.63(0.19), 968.78(0.132)
⁷⁵ As	473.1540(10)	0.176(5)	0.00712(20)	559.10(2.00), 165.0490(0.996), 86.7880(0.579)
¹⁴⁰ Ce	475.04(4)	0.082(7)	0.00177(15)	661.99(0.241), 4766.10(0.113), 4291.08(0.053)
¹⁰¹ Ru	475.0950(20)	0.98(9)	0.029(3)	539.538(1.53), 686.907(0.52), 631.22(0.30)
¹⁶⁴ Dy	477.061(6)	22(7)	0.41(13)	184.257(146), 538.609(69.2), 496.931(44.9)
¹⁶⁴ Dy	477.08(4)	15.8(5)	0.295(9)	184.257(146), 538.609(69.2), 496.931(44.9)
¹⁷⁴ Yb	477.391(5)	0.75(8)	0.0131(14)	514.868(9.0), 639.261(1.43), 396.329(1.42)
¹⁰ B	477.595(3)	716(25)	201(7)	
¹⁸⁷ Os	478.04(4)	0.523(14)	0.00833(22)	186.7180(2.08), 155.10(1.19), 557.978(0.84)
¹⁸⁶ W	479.550(22)d	2.59(5)	0.0427[1.4%]	685.73(3.24), 72.002(1.32), 134.247(1.050)
¹⁷⁴ Yb	482.071(11)	0.23(3)	0.0040(5)	514.868(9.0), 639.261(1.43), 396.329(1.42)
⁵⁹ Co	484.257(16)	0.804(11)	0.0413(6)	229.879(7.18), 277.161(6.77), 555.972(5.76)
¹³⁹ La	487.021(12)d	2.79(4)	0.0609[0.9%]	1596.21(5.84), 815.772(1.430), 328.762(1.250)
⁸⁵ Rb	487.89(4)	0.0494(12)	0.00175(4)	556.82(0.0913), 555.61(0.0407), 872.94(0.0321)
²⁰³ Tl	488.11(8)	0.096(4)	0.00142(6)	139.94(0.400), 347.96(0.361), 318.88(0.325)
¹¹⁵ In	492.532(11)	3.31(24)	0.087(6)	1293.54(131), 1097.30(87.3), 416.86(43.0)
⁷³ Ge	492.933(5)	0.133(3)	0.00555(13)	595.851(1.100), 867.899(0.553), 608.353(0.250)
¹³⁹ La	495.620(13)	0.081(3)	0.00177(7)	1596.21(5.84), 487.021(2.79), 815.772(1.430)
¹⁰⁹ Ag	495.71(3)	1.080(18)	0.0303(5)	198.72(7.75), 235.62(4.62), 78.91(3.90)
¹⁶⁴ Dy	496.931(5)	44.9(11)	0.837(21)	184.257(146), 538.609(69.2), 185.19(39.1)
⁵⁹ Co	497.269(16)	2.16(4)	0.1111(21)	229.879(7.18), 277.161(6.77), 555.972(5.76)
⁹³ Nb	499.426(8)	0.0648(18)	0.00211(6)	99.4070(0.196), 255.9290(0.176), 253.115(0.1320)
¹⁶⁹ Tm	499.5560(20)	0.88(3)	0.0158(5)	200.(8.72), 149.7180(7.11), 140.(5.96)
⁷⁰ Ge	499.87(3)	0.162(6)	0.00676(25)	595.851(1.100), 867.899(0.553), 608.353(0.250)

^A Z	E γ -keV	$\sigma_{\gamma}^z(E_{\gamma})$ -barns	k ₀	E γ , $\sigma_{\gamma}^z(E_{\gamma})$ for associated intense gamma rays
¹³³ Cs	502.840(3)	0.256(13)	0.0058(3)	176.4040(2.47), 205.615(1.560), 510.795(1.54)
¹⁶⁹ Tm	505.018(7)	0.90(3)	0.0161(5)	200.(8.72), 149.7180(7.11), 140.(5.96)
¹⁴⁹ Sm	505.51(3)	528(80)	10.6(16)	333.97(4790), 439.40(2860), 737.44(597)
⁶⁹ Ga	508.19(3)	0.349(6)	0.0152(3)	834.08(1.65), 2201.91(0.52), 629.96(0.490)
¹³³ Cs	510.795(3)	1.54(3)	0.0351(7)	176.4040(2.47), 205.615(1.560), 307.015(1.45)
¹⁷⁴ Yb	511.784(11)	0.34(5)	0.0060(9)	514.868(9.0), 639.261(1.43), 396.329(1.42)
¹⁰⁵ Pd	511.843(20)	4.00(4)	0.1139(11)	717.356(0.777), 616.192(0.629)
¹⁶⁹ Tm	512.1370(20)	1.96(5)	0.0352(9)	200.(8.72), 149.7180(7.11), 140.(5.96)
⁸¹ Br	512.488(20)	0.21(3)	0.0080(11)	776.517(0.990), 554.3480(0.838), 245.203(0.80)
³¹ P	512.646(19)	0.079(4)	0.0077(4)	78.083(0.059), 636.663(0.0311), 3899.89(0.0294)
¹⁷⁴ Yb	514.868(7)d	9.0(9)	0.158[100%]	639.261(1.43), 396.329(1.42), 5266.3(1.4)
⁴⁰ Ar	516.0(3)	0.167(17)	0.0127(13)	167.30(0.53), 4745.3(0.36), 1186.8(0.34)
³⁵ Cl	517.0730(10)	7.58(5)	0.648(4)	1164.8650(8.91), 6110.842(6.59), 1951.1400(6.33)
⁹³ Nb	518.113(12)	0.0579(13)	0.00189(4)	99.4070(0.196), 255.9290(0.176), 253.115(0.1320)
⁷⁶ Se	518.1810(20)	0.273(7)	0.0105(3)	613.724(2.14), 238.9980(2.06), 520.6370(1.260)
¹³³ Cs	519.101(4)	0.349(18)	0.0080(4)	176.4040(2.47), 205.615(1.560), 510.795(1.54)
⁴⁰ Ca	519.66(5)	0.0503(13)	0.00380(10)	1942.67(0.352), 6419.59(0.176), 4418.52(0.0708)
⁷⁶ Se	520.6370(20)	1.260(18)	0.0484(7)	613.724(2.14), 238.9980(2.06), 161.9220(0.855)
²³⁸ U	521.849(7)	0.073(3)	0.00093(4)	74.6640(1.30000), 106.1230(0.723), 277.5990(0.382)
²³² Th	522.73(10)	0.102(5)	0.00133(7)	583.27(0.279), 566.63(0.19), 472.30(0.165)
¹⁰⁹ Ag	524.47(3)	0.804(11)	0.0226(3)	198.72(7.75), 235.62(4.62), 78.91(3.90)
¹³³ Cs	525.356(4)	0.39(3)	0.0089(7)	176.4040(2.47), 205.615(1.560), 510.795(1.54)
¹⁵⁹ Tb	525.933(17)	0.22(3)	0.0042(6)	75.0500(1.78), 63.6860(1.46), 64.1100(1.2)
¹⁹⁰ Os	527.60(3)	0.300(10)	0.00478(16)	186.7180(2.08), 155.10(1.19), 557.978(0.84)
¹⁹⁷ Au	529.1650(20)	1.9(10)	0.029(15)	410.(94.), 214.9710(9.0), 247.5730(5.56)
¹³³ Cs	529.504(6)	0.519(23)	0.0118(5)	176.4040(2.47), 205.615(1.560), 510.795(1.54)
²³² Th	531.58(10)	0.0404(23)	0.00053(3)	583.27(0.279), 566.63(0.19), 472.30(0.165)
¹⁷⁴ Yb	531.735(9)	0.50(6)	0.0088(11)	514.868(9.0), 639.261(1.43), 396.329(1.42)
¹⁶⁹ Tm	535.8280(10)	1.18(4)	0.0212(7)	200.(8.72), 149.7180(7.11), 140.(5.96)
¹⁰⁹ Ag	536.13(3)	1.090(16)	0.0306(5)	198.72(7.75), 235.62(4.62), 78.91(3.90)
¹²⁹ Xe	536.17(9)	1.71(24)	0.039(6)	667.79(6.7), 772.72(1.78), 630.29(1.41)
⁸⁵ Rb	536.48(4)	0.0167(5)	0.000592(18)	556.82(0.0913), 487.89(0.0494), 555.61(0.0407)
¹³⁹ Ba	537.261(9)d	0.066(3)	0.00084[0.1%]	74.6640(1.30000), 106.1230(0.723), 277.5990(0.382)
¹⁶⁹ Tm	537.9910(20)	1.00(4)	0.0179(7)	200.(8.72), 149.7180(7.11), 140.(5.96)
¹⁰³ Rh	538.04(3)	2.43(7)	0.0716(21)	180.87(22.6), 97.14(19.5), 51.50(16.0)
¹⁶⁴ Dy	538.609(8)	69.2(19)	1.29(4)	184.257(146), 496.931(44.9), 185.19(39.1)
⁸⁵ Rb	538.66(4)	0.0169(5)	0.000599(18)	556.82(0.0913), 487.89(0.0494), 555.61(0.0407)
¹³³ Cs	539.180(4)	0.360(11)	0.00821(25)	176.4040(2.47), 205.615(1.560), 510.795(1.54)
²³⁸ U	539.278(12)	0.099(20)	0.00126(25)	74.6640(1.30000), 106.1230(0.723), 277.5990(0.382)
⁴⁵ Sc	539.437(20)	0.738(19)	0.0497(13)	227.773(7.13), 147.011(6.08), 142.528(4.88)
⁹⁹ Ru	539.538(15)	1.53(13)	0.046(4)	475.0950(0.98), 686.907(0.52), 631.22(0.30)
²³² Th	539.66(10)	0.061(3)	0.00080(4)	583.27(0.279), 566.63(0.19), 472.30(0.165)
⁷⁹ Br	542.515(6)	0.114(5)	0.00432(19)	776.517(0.990), 554.3480(0.838), 245.203(0.80)
¹⁶⁵ Ho	542.780(4)	1.94(13)	0.0356(24)	136.6650(14.5), 116.8360(8.1), 80.574(3.87)
¹⁴¹ Pr	546.448(15)	0.148(4)	0.00318(9)	176.8630(1.06), 140.9050(0.479), 1575.6(0.426)
²³² Th	548.23(11)	0.042(10)	0.00055(13)	583.27(0.279), 566.63(0.19), 472.30(0.165)
¹³⁹ La	549.01(3)	0.098(4)	0.00214(9)	1596.21(5.84), 487.021(2.79), 815.772(1.430)
¹⁰⁹ Ag	549.56(3)	1.540(24)	0.0433(7)	198.72(7.75), 235.62(4.62), 78.91(3.90)
¹⁶⁹ Tm	551.5140(20)	1.29(25)	0.023(5)	200.(8.72), 149.7180(7.11), 140.(5.96)
¹⁸⁶ W	551.52(4)d	0.603(14)	0.00994[1.4%]	685.73(3.24), 479.550(2.59), 72.002(1.32)
²³⁸ U	552.069(5)	0.207(5)	0.00264(6)	74.6640(1.30000), 106.1230(0.723), 277.5990(0.382)
²³⁸ U	554.054(8)	0.085(20)	0.00108(25)	74.6640(1.30000), 106.1230(0.723), 277.5990(0.382)
⁸¹ Br	554.3480(20)d	0.838(8)	0.0318[1.0%]	776.517(0.990), 245.203(0.80), 619.106(0.515)
⁴⁵ Sc	554.44(4)	1.82(4)	0.123(3)	227.773(7.13), 147.011(6.08), 142.528(4.88)
⁸⁵ Rb	555.61(3)d	0.0407(10)	0.00144[98%]	556.82(0.0913), 487.89(0.0494), 872.94(0.0321)
¹⁰³ Rh	555.81(4)d	3.14(9)	0.092[98%]	180.87(22.6), 97.14(19.5), 51.50(16.0)
⁵⁹ Co	555.972(13)	5.76(6)	0.296(3)	229.879(7.18), 277.161(6.77), 447.711(3.41)
⁸⁵ Rb	556.82(3)	0.0913(24)	0.00324(9)	487.89(0.0494), 555.61(0.0407), 872.94(0.0321)
¹¹⁵ In	556.845(21)	4.7(3)	0.124(8)	1293.54(131), 1097.30(87.3), 416.86(43.0)
²³² Th	556.93(11)	0.040(10)	0.00052(13)	583.27(0.279), 566.63(0.19), 472.30(0.165)
¹⁸⁶ W	557.16(5)	0.125(5)	0.00206(8)	685.73(3.24), 479.550(2.59), 72.002(1.32)
¹⁴¹ Pr	557.75(3)	0.15(4)	0.0032(9)	176.8630(1.06), 140.9050(0.479), 1575.6(0.426)
¹⁸⁹ Os	557.978(5)	0.84(3)	0.0134(5)	186.7180(2.08), 155.10(1.19), 569.344(0.694)
¹¹³ Cd	558.32(3)	1860(30)	50.1(8)	651.19(358), 245.3(274)
⁷⁵ As	559.10(5)d	2.00(10)	0.081[1.3%]	165.0490(0.996), 86.7880(0.579), 44.4250(0.560)
¹⁴¹ Pr	560.495(23)	0.150(7)	0.00323(15)	176.8630(1.06), 140.9050(0.479), 1575.6(0.426)
⁹¹ Zr	560.958(3)	0.0285(5)	0.000947(17)	934.4640(0.125), 1465.7(0.063), 1205.6(0.042)
²³² Th	561.25(11)	0.033(8)	0.00043(10)	583.27(0.279), 566.63(0.19), 472.30(0.165)
⁹³ Nb	562.328(9)	0.0293(11)	0.00096(4)	99.4070(0.196), 255.9290(0.176), 253.115(0.1320)

^A Z	E _γ -keV	σ _γ ^Z (E _γ)-barns	k ₀	E _γ , σ _γ ^Z (E _γ) for associated intense gamma rays
¹²¹ Sb	564.24(4)d	2.700(4)	0.06720[0.5%]	61.4130(0.75), 78.0910(0.48), 121.4970(0.40)
¹⁶⁹ Tm	565.2770(20)	1.58(4)	0.0283(7)	200.(8.72), 149.7180(7.11), 140.(5.96)
²³² Th	566.63(10)	0.19(5)	0.0025(7)	583.27(0.279), 472.30(0.165), 968.78(0.132)
¹³⁹ La	567.386(12)	0.335(13)	0.0073(3)	1596.21(5.84), 487.021(2.79), 815.772(1.430)
¹⁶⁹ Tm	569.1730(20)	1.02(3)	0.0183(5)	200.(8.72), 149.7180(7.11), 140.(5.96)
¹⁸⁹ Os	569.344(20)	0.694(25)	0.0111(4)	186.7180(2.08), 155.10(1.19), 557.978(0.84)
¹⁴¹ Pr	570.111(14)	0.112(5)	0.00241(11)	176.8630(1.06), 140.9050(0.479), 1575.6(0.426)
¹⁴¹ Pr	573.28(4)	0.12(3)	0.0026(7)	176.8630(1.06), 140.9050(0.479), 1575.6(0.426)
⁸⁹ Y	574.106(20)	0.174(7)	0.00593(24)	6080.171(0.76), 776.613(0.659), 202.53(0.289)
¹⁸⁶ W	577.30(5)	0.191(5)	0.00315(8)	685.73(3.24), 479.550(2.59), 72.002(1.32)
²³² Th	578.02(9)	0.105(5)	0.00137(7)	583.27(0.279), 566.63(0.19), 472.30(0.165)
⁷⁶ Se	578.8550(20)	0.243(5)	0.00933(19)	613.724(2.14), 238.9980(2.06), 520.6370(1.260)
⁶³ Cu	579.75(3)	0.0898(15)	0.00428(7)	278.250(0.893), 7915.62(0.869), 159.281(0.648)
²³⁸ U	580.340(13)	0.043(10)	0.00055(13)	74.6640(1.30000), 106.1230(0.723), 277.5990(0.382)
²³² Th	583.27(9)	0.279(11)	0.00364(14)	566.63(0.19), 472.30(0.165), 968.78(0.132)
¹⁹ F	583.561(16)	0.00356(12)	0.000568(19)	1633.53(0.0096), 656.006(0.00197), 665.207(0.00149)
¹⁶⁴ Dy	583.982(5)	24(7)	0.45(13)	184.257(146), 538.609(69.2), 496.931(44.9)
¹⁴⁹ Sm	584.27(3)	480(70)	9.7(14)	333.97(4790), 439.40(2860), 737.44(597)
⁴⁵ Sc	584.785(13)	1.77(3)	0.1193(20)	227.773(7.13), 147.011(6.08), 142.528(4.88)
²⁴ Mg	585.00(3)	0.0314(11)	0.00392(14)	3916.84(0.0320), 2828.172(0.0240), 1808.668(0.0180)
²³² Th	586.02(10)	0.045(3)	0.00059(4)	583.27(0.279), 566.63(0.19), 472.30(0.165)
¹⁶⁹ Tm	590.2270(20)	1.27(10)	0.0228(18)	200.(8.72), 149.7180(7.11), 140.(5.96)
²³⁸ U	592.309(13)	0.045(12)	0.00057(15)	74.6640(1.30000), 106.1230(0.723), 277.5990(0.382)
²³² Th	593.23(10)	0.043(3)	0.00056(4)	583.27(0.279), 566.63(0.19), 472.30(0.165)
²³⁸ U	593.612(5)	0.108(24)	0.0014(3)	74.6640(1.30000), 106.1230(0.723), 277.5990(0.382)
¹³⁹ La	595.099(12)	0.103(4)	0.00225(9)	1596.21(5.84), 487.021(2.79), 815.772(1.430)
⁷³ Ge	595.851(5)	1.100(24)	0.0459(10)	867.899(0.553), 608.353(0.250), 175.05(0.164)
⁷¹ Ga	601.21(6)d	0.471(22)	0.0205[2.4%]	834.08(1.65), 2201.91(0.52), 629.96(0.490)
¹²³ Te	602.729(17)	2.46(16)	0.058(4)	722.772(0.52), 645.819(0.263)
¹⁶⁹ Tm	603.9900(20)	1.40(5)	0.0251(9)	200.(8.72), 149.7180(7.11), 140.(5.96)
²³² Th	605.41(10)	0.054(4)	0.00071(5)	583.27(0.279), 566.63(0.19), 472.30(0.165)
²³⁸ U	605.581(9)	0.053(12)	0.00067(15)	74.6640(1.30000), 106.1230(0.723), 277.5990(0.382)
⁷³ Ge	608.353(4)	0.250(6)	0.01043(25)	595.851(1.100), 867.899(0.553), 175.05(0.164)
¹¹⁵ In	608.422(11)	3.51(25)	0.093(7)	1293.54(131), 1097.30(87.3), 416.86(43.0)
⁶³ Cu	608.766(23)	0.270(6)	0.0129(3)	278.250(0.893), 7915.62(0.869), 159.281(0.648)
²³⁸ U	612.253(5)	0.23(5)	0.0029(6)	74.6640(1.30000), 106.1230(0.723), 277.5990(0.382)
⁷⁷ Se	613.724(3)	2.14(5)	0.0821(19)	238.9980(2.06), 520.6370(1.260), 161.9220(0.855)
¹⁰⁵ Pd	616.192(20)	0.629(9)	0.0179(3)	511.843(4.00), 717.356(0.777)
⁷⁹ Br	616.3(5)d	0.39(4)	0.0148[62%]	776.517(0.990), 554.3480(0.838), 245.203(0.80)
¹⁴³ Nd	618.062(19)	13.4(3)	0.282(6)	696.499(33.3), 814.12(4.98), 864.301(4.27)
¹⁸⁶ W	618.26(4)d	0.746(17)	0.0123[1.4%]	685.73(3.24), 479.550(2.59), 72.002(1.32)
⁸¹ Br	619.106(4)d	0.515(5)	0.01953[1.0%]	776.517(0.990), 554.3480(0.838), 245.203(0.80)
¹⁴¹ Pr	619.29(4)	0.152(4)	0.00327(9)	176.8630(1.06), 140.9050(0.479), 1575.6(0.426)
²⁰³ Tl	624.46(8)	0.0413(10)	0.000612(15)	139.94(0.400), 347.96(0.361), 318.88(0.325)
¹⁸⁶ W	625.519(10)d	0.129(3)	0.00213[1.4%]	685.73(3.24), 479.550(2.59), 72.002(1.32)
¹³⁸ Ba	627.29(5)	0.294(6)	0.00649(13)	1435.77(0.308), 818.514(0.212), 4095.84(0.155)
⁴⁵ Sc	627.462(18)	2.23(5)	0.150(3)	227.773(7.13), 147.011(6.08), 142.528(4.88)
¹⁰¹ Ru	627.970(22)	0.176(16)	0.0053(5)	539.538(1.53), 475.0950(0.98), 686.907(0.52)
²³⁸ U	629.722(9)	0.073(20)	0.00093(25)	74.6640(1.30000), 106.1230(0.723), 277.5990(0.382)
⁷¹ Ga	629.96(5)d	0.490(22)	0.0213[2.4%]	834.08(1.65), 2201.91(0.52), 601.21(0.471)
¹⁴¹ Pr	630.04(3)	0.16(6)	0.0034(13)	176.8630(1.06), 140.9050(0.479), 1575.6(0.426)
¹³¹ Xe	630.29(4)	1.41(11)	0.0325(25)	667.79(6.7), 772.72(1.78), 536.17(1.71)
¹⁰¹ Ru	631.22(4)	0.30(3)	0.0090(9)	539.538(1.53), 475.0950(0.98), 686.907(0.52)
¹⁶⁷ Er	631.7050(20)	7.9(3)	0.143(5)	184.2850(56), 815.9890(42.5), 198.2440(29.9)
¹⁸⁷ Os	633.14(4)	0.585(16)	0.00932(25)	186.7180(2.08), 155.10(1.19), 557.978(0.84)
¹⁴¹ Pr	633.34(4)	0.113(4)	0.00243(9)	176.8630(1.06), 140.9050(0.479), 1575.6(0.426)
¹⁸⁷ Os	635.02(5)	0.405(12)	0.00645(19)	186.7180(2.08), 155.10(1.19), 557.978(0.84)
³¹ P	636.663(21)	0.0311(14)	0.00304(14)	512.646(0.079), 78.083(0.059), 3899.89(0.0294)
¹⁶⁹ Tm	637.900(3)	1.25(4)	0.0224(7)	200.(8.72), 149.7180(7.11), 140.(5.96)
¹⁶⁹ Tm	637.9020(20)	1.8(3)	0.032(5)	200.(8.72), 149.7180(7.11), 140.(5.96)
²³⁸ U	638.505(12)	0.041(12)	0.00052(15)	74.6640(1.30000), 106.1230(0.723), 277.5990(0.382)
⁸⁵ Rb	638.93(5)	0.0101(13)	0.00036(5)	556.82(0.0913), 487.89(0.0494), 555.61(0.0407)
¹⁷⁴ Yb	639.261(9)	1.43(17)	0.025(3)	514.868(9.0), 396.329(1.42), 5266.3(1.4)
¹³³ Cs	645.453(5)	0.248(13)	0.0057(3)	176.4040(2.47), 205.615(1.560), 510.795(1.54)
⁵¹ V	645.703(13)	0.769(17)	0.0457(10)	1434.10(4.81), 125.082(1.61), 6517.282(0.78)
¹⁴¹ Pr	645.720(24)	0.311(7)	0.00669(15)	176.8630(1.06), 140.9050(0.479), 1575.6(0.426)
¹²³ Te	645.819(20)	0.263(22)	0.0062(5)	602.729(2.46), 722.772(0.52)
⁶³ Cu	648.80(3)	0.102(3)	0.00486(14)	278.250(0.893), 7915.62(0.869), 159.281(0.648)
¹⁶⁹ Tm	650.3720(10)	1.45(5)	0.0260(9)	200.(8.72), 149.7180(7.11), 140.(5.96)

^A Z	E γ -keV	$\sigma_{\gamma}^z(E_{\gamma})$ -barns	k ₀	E γ , $\sigma_{\gamma}^z(E_{\gamma})$ for associated intense gamma rays
⁶⁹ Ga	651.09(3)	0.1030(22)	0.00448(10)	834.08(1.65), 2201.91(0.52), 629.96(0.490)
¹¹³ Cd	651.19(3)	358(5)	9.65(13)	558.32(1860), 245.3(274)
¹⁹ F	656.006(18)	0.00197(7)	0.000314(11)	1633.53(0.0096), 583.561(0.00356), 665.207(0.00149)
⁷⁵ As	657.05(5)d	0.279(14)	0.0113[1.3%]	559.10(2.00), 165.0490(0.996), 86.7880(0.579)
¹⁰⁹ Ag	657.50(10)d	1.86(5)	0.0523[99%]	198.72(7.75), 235.62(4.62), 78.91(3.90)
¹³⁹ La	658.278(12)	0.103(4)	0.00225(9)	1596.21(5.84), 487.021(2.79), 815.772(1.430)
¹⁶⁹ Tm	658.913(5)	1.56(5)	0.0280(9)	200.(8.72), 149.7180(7.11), 140.(5.96)
⁷⁹ Br	660.561(4)	0.082(3)	0.00311(11)	776.517(0.990), 554.3480(0.838), 245.203(0.80)
¹⁴⁰ Ce	661.99(5)	0.241(15)	0.0052(3)	4766.10(0.113), 475.04(0.082), 4291.08(0.053)
²³² Th	665.11(10)	0.084(4)	0.00110(5)	583.27(0.279), 566.63(0.19), 472.30(0.165)
¹⁹ F	665.207(18)	0.00149(6)	2.38E-04(10)	1633.53(0.0096), 583.561(0.00356), 656.006(0.00197)
¹³¹ Xe	667.79(6)	6.7(5)	0.155(12)	772.72(1.78), 536.17(1.71), 630.29(1.41)
²⁰⁹ Bi	673.97(5)	0.0026(4)	3.8E-05(6)	4171.05(0.0171), 4054.57(0.0137), 319.78(0.0115)
²³² Th	681.81(9)	0.079(4)	0.00103(5)	583.27(0.279), 566.63(0.19), 472.30(0.165)
¹⁸⁶ W	685.73(4)d	3.24(7)	0.0534[1.4%]	479.550(2.59), 72.002(1.32), 134.247(1.050)
⁹⁹ Ru	686.907(17)	0.52(5)	0.0156(15)	539.538(1.53), 475.0950(0.98), 631.22(0.30)
²³⁸ U	689.907(11)	0.043(10)	0.00055(13)	74.6640(1.30000), 106.1230(0.723), 277.5990(0.382)
⁷⁹ Br	689.994(16)	0.083(4)	0.00315(15)	776.517(0.990), 554.3480(0.838), 245.203(0.80)
⁶⁹ Ga	690.943(24)	0.305(4)	0.01326(17)	834.08(1.65), 2201.91(0.52), 629.96(0.490)
⁵⁶ Fe	691.960(19)	0.1370(18)	0.00743(10)	7631.136(0.653), 7645.5450(0.549), 352.347(0.273)
¹²¹ Sb	692.65(4)d	0.146(5)	0.00363[0.5%]	564.24(2.700), 61.4130(0.75), 78.0910(0.48)
⁷⁷ Se	694.914(4)	0.443(10)	0.0170(4)	613.724(2.14), 238.9980(2.06), 520.6370(1.260)
¹⁴³ Nd	696.499(10)	33.3(23)	0.70(5)	618.062(13.4), 814.12(4.98), 864.301(4.27)
⁸¹ Br	698.374(5)d	0.337(3)	0.01278[1.0%]	776.517(0.990), 554.3480(0.838), 245.203(0.80)
¹⁴¹ Pr	698.65(3)	0.22(6)	0.0047(13)	176.8630(1.06), 140.9050(0.479), 1575.6(0.426)
¹⁶⁹ Tm	703.6280(10)	1.32(4)	0.0237(7)	200.(8.72), 149.7180(7.11), 140.(5.96)
²³² Th	705.17(11)	0.050(4)	0.00065(5)	583.27(0.279), 566.63(0.19), 472.30(0.165)
¹³⁹ La	708.244(14)	0.134(5)	0.00292(11)	1596.21(5.84), 487.021(2.79), 815.772(1.430)
²³² Th	714.23(10)	0.052(3)	0.00068(4)	583.27(0.279), 566.63(0.19), 472.30(0.165)
⁵⁹ Co	717.310(18)	0.845(14)	0.0435(7)	229.879(7.18), 277.161(6.77), 555.972(5.76)
¹⁰⁵ Pd	717.356(22)	0.777(9)	0.0221(3)	511.843(4.00), 616.192(0.629)
¹⁶⁹ Tm	719.2610(20)	1.01(3)	0.0181(5)	200.(8.72), 149.7180(7.11), 140.(5.96)
⁹⁵ Mo	719.528(14)	0.310(10)	0.0098(3)	778.221(2.02), 849.85(0.43), 847.603(0.324)
¹³⁹ La	722.538(14)	0.212(8)	0.00463(17)	1596.21(5.84), 487.021(2.79), 815.772(1.430)
¹²³ Te	722.772(25)	0.52(4)	0.0123(10)	602.729(2.46), 645.819(0.263)
¹⁶⁷ Er	730.6580(10)	11.6(4)	0.210(7)	184.2850(56), 815.9890(42.5), 198.2440(29.9)
²⁰³ Tl	732.09(9)	0.064(3)	0.00095(4)	139.94(0.400), 347.96(0.361), 318.88(0.325)
²⁰³ Tl	737.12(8)	0.118(5)	0.00175(7)	139.94(0.400), 347.96(0.361), 318.88(0.325)
¹⁴² Ce	737.43(7)	0.026(3)	0.00056(7)	661.99(0.241), 4766.10(0.113), 475.04(0.082)
¹⁴⁹ Sm	737.44(4)	597(8)	12.03(16)	333.97(4790), 439.40(2860), 505.51(528)
¹⁶⁷ Er	741.3650(20)	6.72(24)	0.122(4)	184.2850(56), 815.9890(42.5), 198.2440(29.9)
¹⁴² Nd	742.106(22)	3.8(4)	0.080(8)	696.499(33.3), 618.062(13.4), 814.12(4.98)
¹⁴¹ Pr	746.973(14)	0.146(4)	0.00314(9)	176.8630(1.06), 140.9050(0.479), 1575.6(0.426)
⁵⁰ Cr	749.09(3)	0.569(9)	0.0332(5)	834.849(1.38), 8884.36(0.78), 7938.46(0.424)
¹³⁹ La	751.637(18)d	0.2650(23)	0.00578[0.9%]	1596.21(5.84), 487.021(2.79), 815.772(1.430)
¹⁷⁶ Lu	761.564(20)	2.60(9)	0.0450(16)	150.392(13.8), 457.944(8.3), 138.607(6.79)
¹⁷⁴ Yb	767.169(9)	0.151(25)	0.0026(4)	514.868(9.0), 639.261(1.43), 396.329(1.42)
³⁹ K	770.3050(20)	0.903(12)	0.0700(9)	29.8300(1.380), 1158.887(0.1600), 5380.018(0.146)
¹³¹ Xe	772.72(4)	1.78(14)	0.041(3)	667.79(6.7), 536.17(1.71), 630.29(1.41)
¹⁸⁶ W	772.89(5)d	0.490(10)	0.00808[1.4%]	685.73(3.24), 479.550(2.59), 72.002(1.32)
⁸¹ Br	776.517(3)d	0.990(10)	0.0375[1.0%]	554.3480(0.838), 245.203(0.80), 619.106(0.515)
⁸⁹ Y	776.613(18)	0.659(9)	0.0225(3)	6080.171(0.76), 202.53(0.289), 574.106(0.174)
⁹⁵ Mo	778.221(10)	2.02(6)	0.0638(19)	849.85(0.43), 847.603(0.324), 719.528(0.310)
¹⁵⁷ Gd	780.174(10)	1010(22)	19.5(4)	181.931(7200), 79.5100(4010), 944.174(3090)
¹⁸⁶ W	782.12(6)	0.22(3)	0.0036(5)	685.73(3.24), 479.550(2.59), 72.002(1.32)
⁵⁹ Co	785.628(21)	2.41(7)	0.124(4)	229.879(7.18), 277.161(6.77), 555.972(5.76)
⁷¹ Ga	786.17(16)d	0.160(22)	0.0070[2.4%]	834.08(1.65), 2201.91(0.52), 629.96(0.490)
³⁵ Cl	786.3020(10)	3.420(3)	0.2923(3)	1164.8650(8.91), 517.0730(7.58), 6110.842(6.59)
³⁵ Cl	788.4280(10)	5.42(5)	0.463(4)	1164.8650(8.91), 517.0730(7.58), 6110.842(6.59)
¹⁸³ W	792.059(16)	0.119(6)	0.00196(10)	685.73(3.24), 479.550(2.59), 72.002(1.32)
⁵¹ V	793.546(13)	0.199(5)	0.0118(3)	1434.10(4.81), 125.082(1.61), 6517.282(0.78)
²³² Th	797.79(9)	0.0416(20)	0.00054(3)	583.27(0.279), 566.63(0.19), 472.30(0.165)
⁶⁷ Zn	805.79(3)	0.045(3)	0.00209(14)	1077.335(0.356), 115.225(0.167), 7863.55(0.1410)
¹⁷⁴ Yb	811.427(9)	0.92(16)	0.016(3)	514.868(9.0), 639.261(1.43), 396.329(1.42)
¹⁴³ Nd	814.12(3)	4.98(12)	0.1046(25)	696.499(33.3), 618.062(13.4), 864.301(4.27)
¹³⁹ La	815.772(19)d	1.430(12)	0.0312[0.9%]	1596.21(5.84), 487.021(2.79), 328.762(1.250)
¹⁶⁷ Er	815.9890(20)	42.5(15)	0.77(3)	184.2850(56), 198.2440(29.9), 79.8040(18.2)
¹⁸⁶ W	816.13(5)	0.104(4)	0.00171(7)	685.73(3.24), 479.550(2.59), 72.002(1.32)
¹³⁵ Ba	818.514(12)	0.212(4)	0.00468(9)	1435.77(0.308), 627.29(0.294), 4095.84(0.155)

^A Z	E γ -keV	$\sigma_{\gamma}^z(E_{\gamma})$ -barns	k ₀	E γ , $\sigma_{\gamma}^z(E_{\gamma})$ for associated intense gamma rays
¹¹⁵ In	818.70(20)d	17.8(7)	0.470[30%]	1293.54(131), 1097.30(87.3), 416.86(43.0)
¹⁶⁷ Er	821.1680(20)	6.2(3)	0.112(5)	184.2850(56), 815.9890(42.5), 198.2440(29.9)
⁵¹ V	823.184(13)	0.320(8)	0.0190(5)	1434.10(4.81), 125.082(1.61), 6517.282(0.78)
¹⁷⁴ Yb	825.22(7)	0.154(24)	0.0027(4)	514.868(9.0), 639.261(1.43), 396.329(1.42)
⁸¹ Br	827.828(6)d	0.285(3)	0.01081[1.0%]	776.517(0.990), 554.3480(0.838), 245.203(0.80)
²³⁸ U	831.837(19)	0.053(12)	0.00067(15)	74.6640(1.30000), 106.1230(0.723), 277.5990(0.382)
⁷¹ Ga	834.08(3)d	1.65(5)	0.0717[2.4%]	2201.91(0.52), 629.96(0.490), 601.21(0.471)
⁶⁸ Zn	834.77(3)	0.037(5)	0.00171(23)	1077.335(0.356), 115.225(0.167), 7863.55(0.1410)
²³² Th	834.83(14)	0.059(5)	0.00077(7)	583.27(0.279), 566.63(0.19), 472.30(0.165)
⁵³ Cr	834.849(22)	1.38(3)	0.0804(17)	8884.36(0.78), 749.09(0.569), 7938.46(0.424)
⁹³ Nb	835.72(3)	0.0376(8)	0.00123(3)	99.4070(0.196), 255.9290(0.176), 253.115(0.1320)
⁴⁰ Ar	837.7(3)	0.063(7)	0.0048(5)	167.30(0.53), 4745.3(0.36), 1186.8(0.34)
¹⁸⁶ W	840.18(5)	0.143(5)	0.00236(8)	685.73(3.24), 479.550(2.59), 72.002(1.32)
³² S	840.993(13)	0.347(6)	0.0328(6)	5420.574(0.308), 2379.661(0.208), 3220.588(0.117)
⁵¹ V	845.948(13)	0.252(7)	0.0150(4)	1434.10(4.81), 125.082(1.61), 6517.282(0.78)
⁵⁵ Mn	846.754(20)d	13.10(4)	0.7226[12%]	1810.72(3.62), 26.560(3.42), 83.884(3.11)
⁹⁵ Mo	847.603(11)	0.324(9)	0.0102(3)	778.221(2.02), 849.85(0.43), 719.528(0.310)
⁹⁵ Mo	849.85(3)	0.43(3)	0.0136(10)	778.221(2.02), 847.603(0.324), 719.528(0.310)
⁸⁷ Sr	850.657(12)	0.275(4)	0.00951(14)	1836.067(1.030), 898.055(0.702)
²³⁸ U	853.23(4)	0.055(12)	0.00070(15)	74.6640(1.30000), 106.1230(0.723), 277.5990(0.382)
¹⁶⁷ Er	853.4810(10)	7.5(3)	0.136(5)	184.2850(56), 815.9890(42.5), 198.2440(29.9)
⁹ Be	853.630(12)	0.00208(24)	0.00070(8)	6809.61(0.0058), 3367.448(0.00285), 2590.014(0.00191)
¹⁶⁹ Tm	854.337(4)	1.41(4)	0.0253(7)	200.(8.72), 149.7180(7.11), 140.(5.96)
⁶⁴ Zn	855.69(3)	0.066(6)	0.0031(3)	1077.335(0.356), 115.225(0.167), 7863.55(0.1410)
¹⁷¹ Yb	857.621(7)	0.208(25)	0.0036(4)	514.868(9.0), 639.261(1.43), 396.329(1.42)
²³² Th	860.61(13)	0.047(5)	0.00061(7)	583.27(0.279), 566.63(0.19), 472.30(0.165)
¹⁴³ Nd	864.301(10)	4.27(11)	0.0897(23)	696.499(33.3), 618.062(13.4), 814.12(4.98)
¹⁴¹ Pr	864.98(3)	0.14(3)	0.0030(7)	176.8630(1.06), 140.9050(0.479), 1575.6(0.426)
¹³⁹ La	867.846(20)d	0.337(4)	0.00735[0.9%]	1596.21(5.84), 487.021(2.79), 815.772(1.430)
⁷³ Ge	867.899(5)	0.553(12)	0.0231(5)	595.851(1.100), 608.353(0.250), 175.05(0.164)
²³ Na	869.210(9)	0.1080(13)	0.01424(17)	1368.66(0.530), 2754.13(0.530), 472.202(0.478)
¹⁶ O	870.68(6)	1.77E-04(11)	3.35E-05(21)	2184.42(1.64E-04), 1087.75(1.58E-04), 3272.02(3.53E-05)
¹⁷⁴ Yb	871.695(9)	0.24(4)	0.0042(7)	514.868(9.0), 639.261(1.43), 396.329(1.42)
⁸⁵ Rb	872.94(4)	0.0321(5)	0.001138(18)	556.82(0.0913), 487.89(0.0494), 555.61(0.0407)
²⁰³ Tl	873.16(8)	0.168(4)	0.00249(6)	139.94(0.400), 347.96(0.361), 318.88(0.325)
²³ Na	874.389(6)	0.0760(11)	0.01002(15)	1368.66(0.530), 2754.13(0.530), 472.202(0.478)
⁵⁸ Ni	877.977(11)	0.236(3)	0.01219(15)	8998.414(1.49), 464.978(0.843), 8533.509(0.721)
⁸³ Kr	881.74(11)	20.8(3)	0.752(11)	1213.42(8.28), 1463.86(7.10), 425.30(2.960)
¹⁶¹ Dy	882.27(6)	18.3(6)	0.341(11)	184.257(146), 538.609(69.2), 496.931(44.9)
⁷⁶ Se	885.8270(20)	0.262(7)	0.0101(3)	613.724(2.14), 238.9980(2.06), 520.6370(1.260)
¹⁸⁶ W	891.59(6)	0.136(5)	0.00224(8)	685.73(3.24), 479.550(2.59), 72.002(1.32)
⁷¹ Ga	894.91(11)d	0.35(3)	0.0152[2.4%]	834.08(1.65), 2201.91(0.52), 629.96(0.490)
¹⁵⁷ Gd	897.502(10)	1200(50)	23.1(10)	181.931(7200), 79.5100(4010), 944.174(3090)
¹⁵⁷ Gd	897.611(10)	1090(50)	21.0(10)	181.931(7200), 79.5100(4010), 944.174(3090)
⁸⁷ Sr	898.055(11)	0.702(10)	0.0243(4)	1836.067(1.030), 850.657(0.275)
¹⁸³ W	903.274(17)	0.115(5)	0.00190(8)	685.73(3.24), 479.550(2.59), 72.002(1.32)
¹⁶⁷ Er	914.9420(10)	6.99(24)	0.127(4)	184.2850(56), 815.9890(42.5), 198.2440(29.9)
¹³⁹ La	919.550(23)d	0.1630(18)	0.00356[0.9%]	1596.21(5.84), 487.021(2.79), 815.772(1.430)
¹²¹ Sb	921.00(7)	0.075(4)	0.00187(10)	564.24(2.700), 61.4130(0.75), 78.0910(0.48)
¹³⁹ La	925.189(21)d	0.422(4)	0.00921[0.9%]	1596.21(5.84), 487.021(2.79), 815.772(1.430)
⁹¹ Zr	934.4640(10)	0.125(5)	0.00415(17)	1465.7(0.063), 1205.6(0.042), 2042.2(0.032)
²³⁵ U	943.14(7)	0.082(10)	0.00104(13)	74.6640(1.30000), 106.1230(0.723), 277.5990(0.382)
¹⁵⁷ Gd	944.174(10)	3090(70)	59.5(13)	181.931(7200), 79.5100(4010), 962.104(2050)
⁵⁹ Co	945.314(17)	0.98(4)	0.0504(21)	229.879(7.18), 277.161(6.77), 555.972(5.76)
²⁰³ Tl	949.88(8)	0.0479(15)	0.000710(22)	139.94(0.400), 347.96(0.361), 318.88(0.325)
⁹³ Nb	957.28(5)	0.0248(7)	0.000809(23)	99.4070(0.196), 255.9290(0.176), 253.115(0.1320)
⁷³ Ge	961.055(7)	0.129(4)	0.00538(17)	595.851(1.100), 867.899(0.553), 608.353(0.250)
¹⁵⁷ Gd	962.104(10)	2050(130)	39.5(25)	181.931(7200), 79.5100(4010), 944.174(3090)
¹⁷¹ Yb	964.197(10)	0.229(25)	0.0040(4)	514.868(9.0), 639.261(1.43), 396.329(1.42)
²³² Th	968.78(9)	0.132(6)	0.00172(8)	583.27(0.279), 566.63(0.19), 472.30(0.165)
¹¹⁵ Sn	972.619(17)	0.0158(5)	0.000403(13)	1293.591(0.1340), 1171.28(0.0879), 1229.64(0.0673)
²⁴ Mg	974.66(3)	0.00663(24)	0.00083(3)	3916.84(0.0320), 585.00(0.0314), 2828.172(0.0240)
¹⁵⁷ Gd	977.121(10)	1440(21)	27.8(4)	181.931(7200), 79.5100(4010), 944.174(3090)
¹⁸² W	979.871(18)	0.102(10)	0.00168(16)	685.73(3.24), 479.550(2.59), 72.002(1.32)
⁷ Li	980.53(7)	0.00415(13)	0.00181(6)	2032.30(0.0381), 1051.90(0.00414)
²⁷ Al	982.951(10)	0.00902(14)	0.001013(16)	1778.92(0.232), 30.6380(0.0798), 7724.027(0.0493)
¹⁹ F	983.538(20)	0.00116(4)	1.85E-04(6)	1633.53(0.0096), 583.561(0.00356), 656.006(0.00197)
¹⁴¹ Pr	992.00(4)	0.138(10)	0.00297(22)	176.8630(1.06), 140.9050(0.479), 1575.6(0.426)
¹⁴¹ Pr	1006.361(22)	0.153(8)	0.00329(17)	176.8630(1.06), 140.9050(0.479), 1575.6(0.426)

A_Z	E_γ -keV	$\sigma_\gamma^Z(E_\gamma)$ -barns	k_0	$E_\gamma, \sigma_\gamma^Z(E_\gamma)$ for associated intense gamma rays
⁶⁸ Zn	1007.809(25)	0.056(7)	0.0026(3)	1077.335(0.356), 115.225(0.167), 7863.55(0.1410)
²³² Th	1013.84(11)	0.037(3)	0.00048(4)	583.27(0.279), 566.63(0.19), 472.30(0.165)
²² Ne	1017.00(20)	0.0030(5)	0.00045(8)	2035.67(0.0245), 350.72(0.0198), 4374.13(0.01910)
¹⁸² W	1026.373(17)	0.161(15)	0.00265(25)	685.73(3.24), 479.550(2.59), 72.002(1.32)
⁸⁵ Rb	1026.55(6)	0.0218(4)	0.000773(14)	556.82(0.0913), 487.89(0.0494), 555.61(0.0407)
⁸⁵ Rb	1032.32(5)	0.0227(4)	0.000805(14)	556.82(0.0913), 487.89(0.0494), 555.61(0.0407)
¹⁷¹ Yb	1039.150(7)	0.22(3)	0.0039(5)	514.868(9.0), 639.261(1.43), 396.329(1.42)
⁸¹ Br	1044.002(5)d	0.323(3)	0.01225[1.0%]	776.517(0.990), 554.3480(0.838), 245.203(0.80)
¹³⁸ Ba	1047.73(6)	0.0319(10)	0.000704(22)	1435.77(0.308), 627.29(0.294), 818.514(0.212)
⁷¹ Ga	1050.69(5)d	0.119(13)	0.0052[2.4%]	834.08(1.65), 2201.91(0.52), 629.96(0.490)
⁷ Li	1051.90(7)	0.00414(12)	0.00181(5)	2032.30(0.0381), 980.53(0.00415)
¹⁹ F	1056.776(17)	0.00095(3)	1.52E-04(5)	1633.53(0.0096), 583.561(0.00356), 656.006(0.00197)
³¹ P	1071.217(23)	0.0249(12)	0.00244(12)	512.646(0.079), 78.083(0.059), 636.663(0.0311)
²⁰ Ne	1071.34(7)	0.0054(4)	0.00081(6)	2035.67(0.0245), 350.72(0.0198), 4374.13(0.01910)
¹⁷¹ Yb	1076.246(6)	0.52(6)	0.0091(11)	514.868(9.0), 639.261(1.43), 396.329(1.42)
⁸⁵ Rb	1076.64(20)d	0.0301(5)	0.001067[0.08%]	556.82(0.0913), 487.89(0.0494), 555.61(0.0407)
⁶⁷ Zn	1077.335(16)	0.356(5)	0.01650(23)	115.225(0.167), 7863.55(0.1410), 1883.12(0.0718)
¹⁶ O	1087.75(6)	1.58E-04(7)	2.99E-05(13)	870.68(1.77E-04), 2184.42(1.64E-04), 3272.02(3.53E-05)
¹⁷¹ Yb	1093.674(9)	0.24(3)	0.0042(5)	514.868(9.0), 639.261(1.43), 396.329(1.42)
¹¹⁵ In	1097.30(20)d	87.3(17)	2.30[30%]	1293.54(131), 416.86(43.0), 272.9660(33.1)
⁷³ Ge	1101.282(6)	0.134(3)	0.00559(13)	595.851(1.100), 867.899(0.553), 608.353(0.250)
⁹⁶ Zr	1102.67(6)	0.0235(8)	0.00078(3)	934.4640(0.125), 1465.7(0.063), 1205.6(0.042)
¹⁷⁷ Hf	1102.824(5)	2.96(8)	0.0503(14)	213.439(29.3), 214.3410(16.3), 93.182(13.3)
⁸⁵ Rb	1105.52(10)	0.0151(3)	0.000535(11)	556.82(0.0913), 487.89(0.0494), 555.61(0.0407)
¹⁵⁷ Gd	1107.612(9)	1830(40)	35.3(8)	181.931(7200), 79.5100(4010), 944.174(3090)
¹⁴² Ce	1107.66(5)	0.040(3)	0.00087(7)	661.99(0.241), 4766.10(0.113), 475.04(0.082)
²⁰³ Tl	1110.37(8)	0.0413(12)	0.000612(18)	139.94(0.400), 347.96(0.361), 318.88(0.325)
⁹³ Nb	1118.54(3)	0.022(7)	0.00072(23)	99.4070(0.196), 255.9290(0.176), 253.115(0.1320)
¹⁵⁷ Gd	1119.163(10)	1180(30)	22.7(6)	181.931(7200), 79.5100(4010), 944.174(3090)
¹⁷¹ Yb	1119.780(8)	0.46(6)	0.0081(11)	514.868(9.0), 639.261(1.43), 396.329(1.42)
²⁰³ Tl	1121.29(7)	0.0600(17)	0.000890(25)	139.94(0.400), 347.96(0.361), 318.88(0.325)
²⁵ Mg	1129.575(23)	0.00891(25)	0.00111(3)	3916.84(0.0320), 585.00(0.0314), 2828.172(0.0240)
¹⁴¹ Pr	1150.946(21)	0.141(5)	0.00303(11)	176.8630(1.06), 140.9050(0.479), 1575.6(0.426)
²⁰³ Tl	1155.43(7)	0.0605(17)	0.000897(25)	139.94(0.400), 347.96(0.361), 318.88(0.325)
³⁹ K	1158.887(10)	0.1600(25)	0.01240(19)	29.8300(1.380), 770.3050(0.903), 5380.018(0.146)
³⁵ Cl	1164.8650(10)	8.91(4)	0.762(3)	517.0730(7.58), 6110.842(6.59), 1951.1400(6.33)
¹⁷⁷ Hf	1167.072(6)	3.95(10)	0.0671(17)	213.439(29.3), 214.3410(16.3), 93.182(13.3)
¹¹⁹ Sn	1171.28(6)	0.0879(13)	0.00224(3)	1293.591(0.1340), 1229.64(0.0673), 972.619(0.0158)
¹⁷⁷ Hf	1174.635(5)	4.8(7)	0.081(12)	213.439(29.3), 214.3410(16.3), 93.182(13.3)
¹⁵⁷ Gd	1183.968(10)	958(60)	18.5(12)	181.931(7200), 79.5100(4010), 944.174(3090)
¹⁵⁷ Gd	1185.988(9)	1600(90)	30.8(17)	181.931(7200), 79.5100(4010), 944.174(3090)
⁴⁰ Ar	1186.8(3)	0.34(3)	0.0258(23)	167.30(0.53), 4745.3(0.36), 516.0(0.167)
¹⁵⁷ Gd	1187.122(9)	1420(90)	27.4(17)	181.931(7200), 79.5100(4010), 944.174(3090)
⁷³ Ge	1204.199(6)	0.141(4)	0.00588(17)	595.851(1.100), 867.899(0.553), 608.353(0.250)
⁹⁰ Zr	1205.6(7)	0.042(5)	0.00140(17)	934.4640(0.125), 1465.7(0.063), 2042.2(0.032)
⁹³ Nb	1206.26(5)	0.0284(10)	0.00093(3)	99.4070(0.196), 255.9290(0.176), 253.115(0.1320)
¹⁷⁷ Hf	1207.213(5)	3.9(3)	0.066(5)	213.439(29.3), 214.3410(16.3), 93.182(13.3)
⁸³ Kr	1213.42(12)	8.28(17)	0.299(6)	881.74(20.8), 1463.86(7.10), 425.30(2.960)
⁷⁵ As	1216.08(5)d	0.155(8)	0.0063[1.3%]	559.10(2.00), 165.0490(0.996), 86.7880(0.579)
¹⁷⁷ Hf	1229.287(8)	4.26(11)	0.0723(19)	213.439(29.3), 214.3410(16.3), 93.182(13.3)
¹¹⁷ Sn	1229.64(6)	0.0673(13)	0.00172(3)	1293.591(0.1340), 1171.28(0.0879), 972.619(0.0158)
²⁰³ Tl	1234.69(7)	0.0746(25)	0.00111(4)	139.94(0.400), 347.96(0.361), 318.88(0.325)
⁵⁶ Fe	1260.448(19)	0.0684(11)	0.00371(6)	7631.136(0.653), 7645.5450(0.549), 352.347(0.273)
⁶⁷ Zn	1261.15(3)	0.0431(10)	0.00200(5)	1077.335(0.356), 115.225(0.167), 7863.55(0.1410)
¹³⁵ Ba	1261.52(7)	0.095(5)	0.00210(11)	1435.77(0.308), 627.29(0.294), 818.514(0.212)
¹² C	1261.765(9)	0.00124(3)	0.000313(8)	4945.301(0.00261), 3683.920(0.00122)
²⁸ Si	1273.349(17)	0.0289(6)	0.00312(7)	3538.966(0.1190), 4933.889(0.1120), 2092.902(0.0331)
²³⁵ U	1279.01(10)	0.200(10)	0.00255(13)	74.6640(1.30000), 106.1230(0.723), 277.5990(0.382)
¹¹⁵ In	1293.54(15)d	131(3)	3.46[30%]	1097.30(87.3), 416.86(43.0), 272.9660(33.1)
¹¹⁵ Sn	1293.591(15)	0.1340(21)	0.00342(5)	1171.28(0.0879), 1229.64(0.0673), 972.619(0.0158)
⁷⁶ Se	1296.986(7)	0.240(7)	0.0092(3)	613.724(2.14), 238.9980(2.06), 520.6370(1.260)
⁸⁵ Rb	1304.48(4)	0.0204(5)	0.000723(18)	556.82(0.0913), 487.89(0.0494), 555.61(0.0407)
¹⁷³ Yb	1308.53(11)	0.168(19)	0.0029(3)	514.868(9.0), 639.261(1.43), 396.329(1.42)
⁷⁷ Se	1308.632(5)	0.317(8)	0.0122(3)	613.724(2.14), 238.9980(2.06), 520.6370(1.260)
¹⁹ F	1309.126(17)	0.00076(3)	1.21E-04(5)	1633.53(0.0096), 583.561(0.00356), 656.006(0.00197)
⁸¹ Br	1317.473(10)d	0.314(3)	0.01191[1.0%]	776.517(0.990), 554.3480(0.838), 245.203(0.80)
¹³¹ Xe	1317.93(8)	0.89(7)	0.0205(16)	667.79(6.7), 772.72(1.78), 536.17(1.71)
⁶⁷ Zn	1340.14(3)	0.0457(16)	0.00212(7)	1077.335(0.356), 115.225(0.167), 7863.55(0.1410)
²³ Na	1368.66(3)d	0.530(8)	0.0699[2.3%]	2754.13(0.530), 472.202(0.478), 90.9920(0.235)

^A Z	E _γ -keV	σ _γ ^Z (E _γ)-barns	k ₀	E _γ , σ _γ ^Z (E _γ) for associated intense gamma rays
¹⁷⁴ Yb	1378.22(7)	0.42(12)	0.0074(21)	514.868(9.0), 639.261(1.43), 396.329(1.42)
⁴⁸ Ti	1381.745(5)	5.18(12)	0.328(8)	6760.084(2.97), 6418.426(1.96), 341.706(1.840)
¹⁹ F	1387.901(20)	0.00082(3)	1.31E-04(5)	1633.53(0.0096), 583.561(0.00356), 656.006(0.00197)
⁹¹ Zr	1405.159(3)	0.0301(10)	0.00100(3)	934.4640(0.125), 1465.7(0.063), 1205.6(0.042)
⁵¹ V	1434.10(3)d	4.81(10)	0.286[91%]	125.082(1.61), 6517.282(0.78), 645.703(0.769)
¹³⁷ Ba	1435.77(4)	0.308(7)	0.00680(15)	627.29(0.294), 818.514(0.212), 4095.84(0.155)
¹³⁷ Ba	1444.91(5)	0.0801(20)	0.00177(4)	1435.77(0.308), 627.29(0.294), 818.514(0.212)
⁸³ Kr	1463.86(6)	7.10(8)	0.257(3)	881.74(20.8), 1213.42(8.28), 425.30(2.960)
⁷¹ Ga	1464.00(7)d	0.0609(19)	0.00265[2.4%]	834.08(1.65), 2201.91(0.52), 629.96(0.490)
⁹⁰ Zr	1465.7(7)	0.063(15)	0.0021(5)	934.4640(0.125), 1205.6(0.042), 2042.2(0.032)
⁸¹ Br	1474.880(10)d	0.1930(20)	0.00732[1.0%]	776.517(0.990), 554.3480(0.838), 245.203(0.80)
²⁰³ Tl	1478.77(8)	0.0544(22)	0.00081(3)	139.94(0.400), 347.96(0.361), 318.88(0.325)
¹¹⁵ In	1507.40(20)d	15.5(5)	0.409[30%]	1293.54(131), 1097.30(87.3), 416.86(43.0)
⁵⁹ Co	1515.720(25)	1.740(25)	0.0895(13)	229.879(7.18), 277.161(6.77), 555.972(5.76)
¹⁷¹ Yb	1521.197(16)	0.193(24)	0.0034(4)	514.868(9.0), 639.261(1.43), 396.329(1.42)
⁵¹ V	1558.843(18)	0.323(8)	0.0192(5)	1434.10(4.81), 125.082(1.61), 6517.282(0.78)
¹⁹⁹ Hg	1570.273(12)	29.6(7)	0.447(11)	367.947(251), 5967.02(62.5), 1693.296(56.2)
¹⁴¹ Pr	1575.6(5)d	0.426(12)	0.0092[1.8%]	176.8630(1.06), 140.9050(0.479), 5666.170(0.379)
⁴⁸ Ti	1585.941(5)	0.624(8)	0.0395(5)	1381.745(5.18), 6760.084(2.97), 6418.426(1.96)
¹³⁹ La	1596.21(4)d	5.84(9)	0.1274[0.9%]	487.021(2.79), 815.772(1.430), 328.762(1.250)
⁷¹ Ga	1596.68(8)d	0.0732(16)	0.00318[2.4%]	834.08(1.65), 2201.91(0.52), 629.96(0.490)
³⁵ Cl	1601.072(4)	1.210(7)	0.1034(6)	1164.8650(8.91), 517.0730(7.58), 6110.842(6.59)
⁵⁶ Fe	1612.786(18)	0.1530(22)	0.00830(12)	7631.136(0.653), 7645.5450(0.549), 352.347(0.273)
²⁷ Al	1622.877(18)	0.00989(15)	0.001111(17)	1778.92(0.232), 30.6380(0.0798), 7724.027(0.0493)
¹⁹ F	1633.53(3)d	0.0096(4)	0.00153[100%]	583.561(0.00356), 656.006(0.00197), 665.207(0.00149)
²³ Na	1636.293(21)	0.0250(7)	0.00330(9)	1368.66(0.530), 2754.13(0.530), 472.202(0.478)
¹⁷³ Yb	1638.36(17)	0.22(3)	0.0039(5)	514.868(9.0), 639.261(1.43), 396.329(1.42)
¹⁴ N	1678.281(14)	0.0063(3)	0.00136(7)	5269.159(0.0236), 5297.821(0.01680), 5533.395(0.0155)
¹⁷³ Yb	1679.70(14)	0.161(19)	0.0028(3)	514.868(9.0), 639.261(1.43), 396.329(1.42)
¹⁹⁹ Hg	1693.296(11)	56.2(16)	0.849(24)	367.947(251), 5967.02(62.5), 4739.43(30.1)
⁵⁶ Fe	1725.288(21)	0.181(3)	0.00982(16)	7631.136(0.653), 7645.5450(0.549), 352.347(0.273)
²⁰³ Tl	1741.01(8)	0.0548(25)	0.00081(4)	139.94(0.400), 347.96(0.361), 318.88(0.325)
¹¹⁵ In	1753.8(6)d	3.82(12)	0.101[30%]	1293.54(131), 1097.30(87.3), 416.86(43.0)
⁵¹ V	1777.961(19)	0.169(13)	0.0101(8)	1434.10(4.81), 125.082(1.61), 6517.282(0.78)
²⁷ Al	1778.92(3)d	0.232(4)	0.0261[95%]	30.6380(0.0798), 7724.027(0.0493), 3033.896(0.0179)
⁵³ Cr	1784.70(4)	0.1760(20)	0.01026(12)	834.849(1.38), 8884.36(0.78), 749.09(0.569)
²⁵ Mg	1808.668(22)	0.0180(5)	0.00224(6)	3916.84(0.0320), 585.00(0.0314), 2828.172(0.0240)
⁵⁵ Mn	1810.72(4)d	3.62(11)	0.200[12%]	846.754(13.10), 26.560(3.42), 83.884(3.11)
⁵⁹ Co	1830.800(25)	1.700(23)	0.0874(12)	229.879(7.18), 277.161(6.77), 555.972(5.76)
⁸⁷ Sr	1836.067(21)	1.030(18)	0.0356(6)	898.055(0.702), 850.657(0.275)
¹⁹ F	1843.688(20)	0.000600(23)	9.6E-05(4)	1633.53(0.0096), 583.561(0.00356), 656.006(0.00197)
⁷¹ Ga	1861.09(6)d	0.0904(19)	0.00393[2.4%]	834.08(1.65), 2201.91(0.52), 629.96(0.490)
⁹⁰ Zr	1880.4(4)	0.016(4)	0.00053(13)	934.4640(0.125), 1465.7(0.063), 1205.6(0.042)
⁶⁷ Zn	1883.12(3)	0.0718(18)	0.00333(8)	1077.335(0.356), 115.225(0.167), 7863.55(0.1410)
¹⁴ N	1884.821(16)	0.01470(18)	0.00318(4)	5269.159(0.0236), 5297.821(0.01680), 5533.395(0.0155)
⁸⁵ Rb	1890.7(4)	0.017(4)	0.00060(14)	556.82(0.0913), 487.89(0.0494), 555.61(0.0407)
⁸³ Kr	1897.79(8)	2.24(3)	0.0810(11)	881.74(20.8), 1213.42(8.28), 1463.86(7.10)
²⁰ Ne	1931.08(6)	0.00591(22)	0.00089(3)	2035.67(0.0245), 350.72(0.0198), 4374.13(0.01910)
⁴⁰ Ca	1942.67(3)	0.352(7)	0.0266(5)	6419.59(0.176), 4418.52(0.0708), 2001.31(0.0659)
³⁵ Cl	1951.1400(20)	6.33(4)	0.541(3)	1164.8650(8.91), 517.0730(7.58), 6110.842(6.59)
¹⁰² Ru	1959.30(7)	0.210(19)	0.0063(6)	539.538(1.53), 475.0950(0.98), 686.907(0.52)
³⁵ Cl	1959.346(4)	4.10(3)	0.350(3)	1164.8650(8.91), 517.0730(7.58), 6110.842(6.59)
²² Ne	1979.89(6)	0.00306(17)	0.00046(3)	2035.67(0.0245), 350.72(0.0198), 4374.13(0.01910)
¹⁴ N	1999.690(16)	0.00323(4)	0.000699(9)	5269.159(0.0236), 5297.821(0.01680), 5533.395(0.0155)
⁴⁰ Ca	2001.31(3)	0.0659(15)	0.00498(11)	1942.67(0.352), 6419.59(0.176), 4418.52(0.0708)
⁴⁰ Ca	2009.84(3)	0.0409(10)	0.00309(8)	1942.67(0.352), 6419.59(0.176), 4418.52(0.0708)
²³ Na	2025.139(22)	0.0341(8)	0.00450(11)	1368.66(0.530), 2754.13(0.530), 472.202(0.478)
⁷ Li	2032.30(4)	0.0381(8)	0.0166(4)	980.53(0.00415), 1051.90(0.00414)
²⁰ Ne	2035.67(20)	0.0245(25)	0.0037(4)	350.72(0.0198), 4374.13(0.01910), 2793.94(0.00900)
⁹⁰ Zr	2042.2(4)	0.032(8)	0.0011(3)	934.4640(0.125), 1465.7(0.063), 1205.6(0.042)
²⁸ Si	2092.902(18)	0.0331(6)	0.00357(7)	3538.966(0.1190), 4933.889(0.1120), 1273.349(0.0289)
¹¹⁵ In	2112.1(4)d	24.1(7)	0.636[30%]	1293.54(131), 1097.30(87.3), 416.86(43.0)
¹¹⁵ Sn	2112.302(16)	0.0152(5)	0.000388(13)	1293.591(0.1340), 1171.28(0.0879), 1229.64(0.0673)
⁵⁵ Mn	2113.05(4)d	1.91(5)	0.105[12%]	846.754(13.10), 1810.72(3.62), 26.560(3.42)
³¹ P	2114.47(3)	0.0115(5)	0.00113(5)	512.646(0.079), 78.083(0.059), 636.663(0.0311)
³¹ P	2151.52(4)	0.0100(5)	0.00098(5)	512.646(0.079), 78.083(0.059), 636.663(0.0311)
³¹ P	2156.90(4)	0.0128(6)	0.00125(6)	512.646(0.079), 78.083(0.059), 636.663(0.0311)
¹⁶ O	2184.42(7)	1.64E-04(7)	3.11E-05(13)	870.68(1.77E-04), 1087.75(1.58E-04), 3272.02(3.53E-05)
⁷¹ Ga	2201.91(13)d	0.52(4)	0.0226[2.4%]	834.08(1.65), 629.96(0.490), 601.21(0.471)

^A Z	E γ -keV	$\sigma_{\gamma}^z(E_{\gamma})$ -barns	k ₀	E γ , $\sigma_{\gamma}^z(E_{\gamma})$ for associated intense gamma rays
²³ Na	2208.40(3)	0.0259(9)	0.00341(12)	1368.66(0.530), 2754.13(0.530), 472.202(0.478)
¹³⁷ Ba	2217.84(8)	0.044(5)	0.00097(11)	1435.77(0.308), 627.29(0.294), 818.514(0.212)
¹ H	2223.24835(9)	0.3326(7)	1.0000(21)	
⁵³ Cr	2239.04(8)	0.186(3)	0.01084(17)	834.849(1.38), 8884.36(0.78), 749.09(0.569)
²⁷ Al	2282.794(9)	0.00890(17)	0.001000(19)	1778.92(0.232), 30.6380(0.0798), 7724.027(0.0493)
³² S	2379.661(14)	0.208(5)	0.0197(5)	840.993(0.347), 5420.574(0.308), 3220.588(0.117)
¹⁷¹ Yb	2401.37(3)	0.20(3)	0.0035(5)	514.868(9.0), 639.261(1.43), 396.329(1.42)
²³ Na	2414.457(21)	0.0237(5)	0.00312(7)	1368.66(0.530), 2754.13(0.530), 472.202(0.478)
¹⁹ F	2431.084(10)	0.000392(24)	6.3E-05(4)	1633.53(0.0096), 583.561(0.00356), 656.006(0.00197)
²⁴ Mg	2438.54(3)	0.00473(19)	0.000590(24)	3916.84(0.0320), 585.00(0.0314), 2828.172(0.0240)
⁷¹ Ga	2491.6(3)d	0.17(4)	0.0074[2.4%]	834.08(1.65), 2201.91(0.52), 629.96(0.490)
²⁰⁹ Bi	2505.35(7)	0.0021(3)	3.0E-05(4)	4171.05(0.0171), 4054.57(0.0137), 319.78(0.0115)
⁷¹ Ga	2507.40(12)d	0.28(4)	0.0122[2.4%]	834.08(1.65), 2201.91(0.52), 629.96(0.490)
²³ Na	2517.81(3)	0.0699(15)	0.00921(20)	1368.66(0.530), 2754.13(0.530), 472.202(0.478)
¹⁴ N	2520.457(17)	0.00441(24)	0.00095(5)	5269.159(0.0236), 5297.821(0.01680), 5533.395(0.0155)
¹³⁹ La	2521.40(5)d	0.2120(23)	0.00463[0.9%]	1596.21(5.84), 487.021(2.79), 815.772(1.430)
¹⁹ F	2529.212(18)	0.00061(3)	9.7E-05(5)	1633.53(0.0096), 583.561(0.00356), 656.006(0.00197)
⁹⁰ Zr	2557.8(8)	0.016(4)	0.00053(13)	934.4640(0.125), 1465.7(0.063), 1205.6(0.042)
⁹⁰ Zr	2577.3(14)	0.016(4)	0.00053(13)	934.4640(0.125), 1465.7(0.063), 1205.6(0.042)
³¹ P	2586.00(4)	0.0089(4)	0.00087(4)	512.646(0.079), 78.083(0.059), 636.663(0.0311)
⁹ Be	2590.014(19)	0.00191(15)	0.00064(5)	6809.61(0.0058), 3367.448(0.00285), 853.630(0.00208)
²⁷ Al	2590.193(9)	0.00807(16)	0.000906(18)	1778.92(0.232), 30.6380(0.0798), 7724.027(0.0493)
²³ Na	2752.271(23)	0.0654(12)	0.00862(16)	1368.66(0.530), 2754.13(0.530), 472.202(0.478)
²³ Na	2754.13(6)d	0.530(8)	0.0699[2.3%]	1368.66(0.530), 472.202(0.478), 90.9920(0.235)
⁴⁰ Ar	2771.9(8)	0.057(9)	0.0043(7)	167.30(0.53), 4745.3(0.36), 1186.8(0.34)
²⁰ Ne	2793.94(5)	0.00900(11)	0.001352(17)	2035.67(0.0245), 350.72(0.0198), 4374.13(0.01910)
²⁴ Mg	2828.172(25)	0.0240(8)	0.00299(10)	3916.84(0.0320), 585.00(0.0314), 1808.668(0.0180)
²⁰⁹ Bi	2828.29(7)	0.00179(24)	2.6E-05(4)	4171.05(0.0171), 4054.57(0.0137), 319.78(0.0115)
³⁵ Cl	2863.819(12)	1.820(10)	0.1556(9)	1164.8650(8.91), 517.0730(7.58), 6110.842(6.59)
²⁰ Ne	2895.32(10)	0.00252(7)	0.000378(11)	2035.67(0.0245), 350.72(0.0198), 4374.13(0.01910)
³² S	2930.67(3)	0.0832(13)	0.00786(12)	840.993(0.347), 5420.574(0.308), 2379.661(0.208)
¹⁹ F	3014.568(10)	0.000405(15)	6.46E-05(24)	1633.53(0.0096), 583.561(0.00356), 656.006(0.00197)
²⁷ Al	3033.896(6)	0.0179(3)	0.00201(3)	1778.92(0.232), 30.6380(0.0798), 7724.027(0.0493)
⁷¹ Ga	3034.6(4)d	0.15(3)	0.0065[2.4%]	834.08(1.65), 2201.91(0.52), 629.96(0.490)
²⁴ Mg	3054.00(3)	0.0083(3)	0.00103(4)	3916.84(0.0320), 585.00(0.0314), 2828.172(0.0240)
³¹ P	3058.17(4)	0.0110(4)	0.00108(4)	512.646(0.079), 78.083(0.059), 636.663(0.0311)
³⁵ Cl	3061.82(4)	1.130(7)	0.0966(6)	1164.8650(8.91), 517.0730(7.58), 6110.842(6.59)
¹³⁹ La	3082.979(24)	0.140(5)	0.00305(11)	1596.21(5.84), 487.021(2.79), 815.772(1.430)
³² S	3220.588(17)	0.117(5)	0.0111(5)	840.993(0.347), 5420.574(0.308), 2379.661(0.208)
¹⁶ O	3272.02(8)	3.53E-05(23)	6.7E-06(4)	870.68(1.77E-04), 2184.42(1.64E-04), 1087.75(1.58E-04)
³¹ P	3273.98(4)	0.0083(3)	0.00081(3)	512.646(0.079), 78.083(0.059), 636.663(0.0311)
²⁴ Mg	3301.41(3)	0.00620(24)	0.00077(3)	3916.84(0.0320), 585.00(0.0314), 2828.172(0.0240)
⁹ Be	3367.448(25)	0.00285(22)	0.00096(7)	6809.61(0.0058), 853.630(0.00208), 2590.014(0.00191)
²⁴ Mg	3413.10(3)	0.00401(16)	0.000500(20)	3916.84(0.0320), 585.00(0.0314), 2828.172(0.0240)
⁹ Be	3443.406(20)	0.00098(7)	0.000330(24)	6809.61(0.0058), 3367.448(0.00285), 853.630(0.00208)
²⁷ Al	3465.058(7)	0.0146(3)	0.00164(3)	1778.92(0.232), 30.6380(0.0798), 7724.027(0.0493)
¹⁸⁶ W	3469.40(14)	0.103(6)	0.00170(10)	685.73(3.24), 479.550(2.59), 72.002(1.32)
²³² Th	3473.00(8)	0.057(3)	0.00074(4)	583.27(0.279), 566.63(0.19), 472.30(0.165)
⁹⁰ Zr	3475.8(15)	0.019(5)	0.00063(17)	934.4640(0.125), 1465.7(0.063), 1205.6(0.042)
¹⁹ F	3488.064(18)	0.00073(3)	1.16E-04(5)	1633.53(0.0096), 583.561(0.00356), 656.006(0.00197)
³¹ P	3522.59(3)	0.0219(8)	0.00214(8)	512.646(0.079), 78.083(0.059), 636.663(0.0311)
²³² Th	3530.96(13)	0.0397(24)	0.00052(3)	583.27(0.279), 566.63(0.19), 472.30(0.165)
¹⁴ N	3531.981(15)	0.0071(4)	0.00154(9)	5269.159(0.0236), 5297.821(0.01680), 5533.395(0.0155)
²⁸ Si	3538.966(22)	0.1190(20)	0.01284(22)	4933.889(0.1120), 2092.902(0.0331), 1273.349(0.0289)
²³⁸ U	3583.10(7)	0.042(3)	0.00053(4)	74.6640(1.30000), 106.1230(0.723), 277.5990(0.382)
²³ Na	3587.460(25)	0.0596(11)	0.00786(15)	1368.66(0.530), 2754.13(0.530), 472.202(0.478)
²⁷ Al	3591.189(8)	0.01000(21)	0.001123(24)	1778.92(0.232), 30.6380(0.0798), 7724.027(0.0493)
¹⁷⁴ Yb	3632.3(10)	0.40(10)	0.0070(18)	514.868(9.0), 639.261(1.43), 396.329(1.42)
¹³⁸ Ba	3641.12(9)	0.0562(16)	0.00124(4)	1435.77(0.308), 627.29(0.294), 818.514(0.212)
¹³⁹ La	3665.631(24)	0.135(5)	0.00295(11)	1596.21(5.84), 487.021(2.79), 815.772(1.430)
¹⁴ N	3677.732(13)	0.0115(6)	0.00249(13)	5269.159(0.0236), 5297.821(0.01680), 5533.395(0.0155)
¹³⁹ La	3679.641(24)	0.139(5)	0.00303(11)	1596.21(5.84), 487.021(2.79), 815.772(1.430)
¹² C	3683.920(9)	0.00122(3)	0.000308(8)	4945.301(0.00261), 1261.765(0.00124)
⁴⁰ Ar	3700.6(8)	0.065(7)	0.0049(5)	167.30(0.53), 4745.3(0.36), 1186.8(0.34)
¹⁷⁴ Yb	3714.7(5)	0.23(6)	0.0040(11)	514.868(9.0), 639.261(1.43), 396.329(1.42)
¹⁴¹ Pr	3790.37(3)	0.140(6)	0.00301(13)	176.8630(1.06), 140.9050(0.479), 1575.6(0.426)
²⁵ Mg	3831.480(24)	0.00418(14)	0.000521(17)	3916.84(0.0320), 585.00(0.0314), 2828.172(0.0240)
¹⁷⁴ Yb	3885.0(4)	0.72(17)	0.013(3)	514.868(9.0), 639.261(1.43), 396.329(1.42)
³¹ P	3899.89(3)	0.0294(10)	0.00288(10)	512.646(0.079), 78.083(0.059), 636.663(0.0311)

^A Z	E γ -keV	$\sigma_{\gamma}^z(E_{\gamma})$ -barns	k ₀	E γ , $\sigma_{\gamma}^z(E_{\gamma})$ for associated intense gamma rays
²⁴ Mg	3916.84(3)	0.0320(11)	0.00399(14)	585.00(0.0314), 2828.172(0.0240), 1808.668(0.0180)
¹⁷⁴ Yb	3929.3(4)	0.38(9)	0.0067(16)	514.868(9.0), 639.261(1.43), 396.329(1.42)
¹⁹ F	3964.872(20)	0.000435(18)	6.9E-05(3)	1633.53(0.0096), 583.561(0.00356), 656.006(0.00197)
²³ Na	3981.450(25)	0.0677(11)	0.00892(15)	1368.66(0.530), 2754.13(0.530), 472.202(0.478)
⁹⁰ Zr	3982.3(15)	0.015(4)	0.00050(13)	934.4640(0.125), 1465.7(0.063), 1205.6(0.042)
²⁰⁹ Bi	4054.57(6)	0.0137(18)	2.0E-04(3)	4171.05(0.0171), 319.78(0.0115), 4101.76(0.0089)
²³⁸ U	4060.35(5)	0.186(3)	0.00237(4)	74.6640(1.30000), 106.1230(0.723), 277.5990(0.382)
¹³⁸ Ba	4095.84(9)	0.155(4)	0.00342(9)	1435.77(0.308), 627.29(0.294), 818.514(0.212)
²⁰⁹ Bi	4101.76(6)	0.0089(12)	1.29E-04(17)	4171.05(0.0171), 4054.57(0.0137), 319.78(0.0115)
²⁷ Al	4133.407(7)	0.0149(3)	0.00167(3)	1778.92(0.232), 30.6380(0.0798), 7724.027(0.0493)
²⁰⁹ Bi	4165.36(5)	0.00173(24)	2.5E-05(4)	4171.05(0.0171), 4054.57(0.0137), 319.78(0.0115)
²⁰⁹ Bi	4171.05(9)	0.0171(22)	2.5E-04(3)	4054.57(0.0137), 319.78(0.0115), 4101.76(0.0089)
⁵⁶ Fe	4218.27(5)	0.099(3)	0.00537(16)	7631.136(0.653), 7645.5450(0.549), 352.347(0.273)
²⁰³ Tl	4225.47(17)	0.045(3)	0.00067(4)	139.94(0.400), 347.96(0.361), 318.88(0.325)
¹⁸⁶ W	4249.66(7)	0.115(6)	0.00190(10)	685.73(3.24), 479.550(2.59), 72.002(1.32)
²⁰⁹ Bi	4256.65(5)	0.0024(3)	3.5E-05(4)	4171.05(0.0171), 4054.57(0.0137), 319.78(0.0115)
²⁷ Al	4259.534(7)	0.0153(3)	0.00172(3)	1778.92(0.232), 30.6380(0.0798), 7724.027(0.0493)
¹⁴⁰ Ce	4291.08(4)	0.053(4)	0.00115(9)	661.99(0.241), 4766.10(0.113), 475.04(0.082)
¹⁴² Ce	4336.46(8)	0.0251(20)	0.00054(4)	661.99(0.241), 4766.10(0.113), 475.04(0.082)
²⁰ Ne	4374.13(6)	0.01910(22)	0.00287(3)	2035.67(0.0245), 350.72(0.0198), 2793.94(0.00900)
¹³⁹ La	4389.505(14)	0.255(10)	0.00556(22)	1596.21(5.84), 487.021(2.79), 815.772(1.430)
¹³⁹ La	4416.22(3)	0.247(9)	0.00539(20)	1596.21(5.84), 487.021(2.79), 815.772(1.430)
⁴⁰ Ca	4418.52(5)	0.0708(18)	0.00535(14)	1942.67(0.352), 6419.59(0.176), 2001.31(0.0659)
²⁰³ Tl	4495.74(13)	0.043(4)	0.00064(6)	139.94(0.400), 347.96(0.361), 318.88(0.325)
¹³⁹ La	4502.647(13)	0.164(6)	0.00358(13)	1596.21(5.84), 487.021(2.79), 815.772(1.430)
¹⁴ N	4508.731(12)	0.0132(7)	0.00286(15)	5269.159(0.0236), 5297.821(0.01680), 5533.395(0.0155)
²⁰³ Tl	4540.62(15)	0.0413(25)	0.00061(4)	139.94(0.400), 347.96(0.361), 318.88(0.325)
¹⁹ F	4556.817(20)	0.000517(23)	8.2E-05(4)	1633.53(0.0096), 583.561(0.00356), 656.006(0.00197)
¹⁸⁴ W	4573.7(3)	0.104(9)	0.00171(15)	685.73(3.24), 479.550(2.59), 72.002(1.32)
¹⁸⁶ W	4574.94(8)	0.152(10)	0.00251(16)	685.73(3.24), 479.550(2.59), 72.002(1.32)
¹⁸⁶ W	4626.35(7)	0.124(7)	0.00204(12)	685.73(3.24), 479.550(2.59), 72.002(1.32)
³¹ P	4671.37(3)	0.0194(7)	0.00190(7)	512.646(0.079), 78.083(0.059), 636.663(0.0311)
¹⁸⁶ W	4684.40(8)	0.150(7)	0.00247(12)	685.73(3.24), 479.550(2.59), 72.002(1.32)
²⁰³ Tl	4687.58(12)	0.098(4)	0.00145(6)	139.94(0.400), 347.96(0.361), 318.88(0.325)
²⁷ Al	4690.676(5)	0.01090(24)	0.00122(3)	1778.92(0.232), 30.6380(0.0798), 7724.027(0.0493)
¹⁴¹ Pr	4692.120(22)	0.291(10)	0.00626(22)	176.8630(1.06), 140.9050(0.479), 1575.6(0.426)
²⁰³ Tl	4705.83(14)	0.058(3)	0.00086(4)	139.94(0.400), 347.96(0.361), 318.88(0.325)
²⁷ Al	4733.844(11)	0.0126(3)	0.00142(3)	1778.92(0.232), 30.6380(0.0798), 7724.027(0.0493)
¹⁹⁹ Hg	4739.43(5)	30.1(8)	0.455(12)	367.947(251), 5967.02(62.5), 1693.296(56.2)
⁴⁰ Ar	4745.3(8)	0.36(4)	0.027(3)	167.30(0.53), 1186.8(0.34), 516.0(0.167)
²⁰³ Tl	4752.24(11)	0.148(5)	0.00219(7)	139.94(0.400), 347.96(0.361), 318.88(0.325)
¹⁴⁰ Ce	4766.10(5)	0.113(8)	0.00244(17)	661.99(0.241), 475.04(0.082), 4291.08(0.053)
¹⁴¹ Pr	4801.22(3)	0.140(8)	0.00301(17)	176.8630(1.06), 140.9050(0.479), 1575.6(0.426)
¹⁷⁴ Yb	4830.2(4)	0.25(6)	0.0044(11)	514.868(9.0), 639.261(1.43), 396.329(1.42)
²⁰³ Tl	4841.40(15)	0.090(4)	0.00133(6)	139.94(0.400), 347.96(0.361), 318.88(0.325)
¹³⁹ La	4842.695(7)	0.661(25)	0.0144(6)	1596.21(5.84), 487.021(2.79), 815.772(1.430)
³² S	4869.61(3)	0.0650(13)	0.00614(12)	840.993(0.347), 5420.574(0.308), 2379.661(0.208)
¹³⁹ La	4888.606(7)	0.150(6)	0.00327(13)	1596.21(5.84), 487.021(2.79), 815.772(1.430)
²⁰³ Tl	4913.57(11)	0.164(5)	0.00243(7)	139.94(0.400), 347.96(0.361), 318.88(0.325)
²⁸ Si	4933.889(24)	0.1120(23)	0.01209(25)	3538.966(0.1190), 2092.902(0.0331), 1273.349(0.0289)
¹² C	4945.301(3)	0.00261(5)	0.000659(13)	1261.765(0.00124), 3683.920(0.00122)
³⁵ Cl	4979.759(20)	1.230(10)	0.1051(9)	1164.8650(8.91), 517.0730(7.58), 6110.842(6.59)
¹⁷⁴ Yb	5011.0(4)	0.18(4)	0.0032(7)	514.868(9.0), 639.261(1.43), 396.329(1.42)
⁵⁵ Mn	5014.37(7)	0.737(20)	0.0407(11)	846.754(13.10), 1810.72(3.62), 26.560(3.42)
²⁰³ Tl	5014.61(15)	0.058(3)	0.00086(4)	139.94(0.400), 347.96(0.361), 318.88(0.325)
¹⁹ F	5033.530(23)	0.00063(3)	1.00E-04(5)	1633.53(0.0096), 583.561(0.00356), 656.006(0.00197)
¹⁴¹ Pr	5096.081(15)	0.208(8)	0.00447(17)	176.8630(1.06), 140.9050(0.479), 1575.6(0.426)
¹³⁹ La	5097.726(6)	0.68(3)	0.0148(7)	1596.21(5.84), 487.021(2.79), 815.772(1.430)
⁹³ Nb	5103.34(7)	0.0232(12)	0.00076(4)	99.4070(0.196), 255.9290(0.176), 253.115(0.1320)
¹³⁹ La	5126.257(6)	0.114(4)	0.00249(9)	1596.21(5.84), 487.021(2.79), 815.772(1.430)
²⁰³ Tl	5130.50(23)	0.058(4)	0.00086(6)	139.94(0.400), 347.96(0.361), 318.88(0.325)
¹⁴¹ Pr	5140.72(3)	0.269(11)	0.00579(24)	176.8630(1.06), 140.9050(0.479), 1575.6(0.426)
¹⁶⁴ Dy	5142.29(3)	15.7(10)	0.293(19)	184.257(146), 538.609(69.2), 496.931(44.9)
⁵¹ V	5142.363(23)	0.200(6)	0.0119(4)	1434.10(4.81), 125.082(1.61), 6517.282(0.78)
¹⁹⁰ Os	5146.63(14)	0.409(20)	0.0065(3)	186.7180(2.08), 155.10(1.19), 557.978(0.84)
¹⁹¹ Ir	5147.51(12)	1.29(6)	0.0203(10)	351.689(10.9), 328.448(9.1), 84.2740(7.7)
¹³⁹ La	5160.902(6)	0.089(5)	0.00194(11)	1596.21(5.84), 487.021(2.79), 815.772(1.430)
¹⁸² W	5164.43(3)	0.19(3)	0.0031(5)	685.73(3.24), 479.550(2.59), 72.002(1.32)
²⁰³ Tl	5180.38(12)	0.141(5)	0.00209(7)	139.94(0.400), 347.96(0.361), 318.88(0.325)

^A Z	E _γ -keV	σ _γ ^Z (E _γ)-barns	k ₀	E _γ , σ _γ ^Z (E _γ) for associated intense gamma rays
⁵⁵ Mn	5180.89(8)	0.412(13)	0.0227(7)	846.754(13.10), 1810.72(3.62), 26.560(3.42)
⁵⁹ Co	5181.77(7)	0.912(23)	0.0469(12)	229.879(7.18), 277.161(6.77), 555.972(5.76)
⁵¹ V	5210.143(19)	0.244(20)	0.0145(12)	1434.10(4.81), 125.082(1.61), 6517.282(0.78)
²⁰³ Tl	5261.48(13)	0.084(4)	0.00125(6)	139.94(0.400), 347.96(0.361), 318.88(0.325)
¹⁸⁶ W	5261.68(6)	0.86(4)	0.0142(7)	685.73(3.24), 479.550(2.59), 72.002(1.32)
¹⁷⁴ Yb	5266.3(4)	1.4(6)	0.025(11)	514.868(9.0), 639.261(1.43), 396.329(1.42)
¹⁴ N	5269.159(13)	0.0236(3)	0.00511(7)	5297.821(0.01680), 5533.395(0.0155), 1884.821(0.01470)
¹⁹ F	5279.360(20)	0.000421(20)	6.7E-05(3)	1633.53(0.0096), 583.561(0.00356), 656.006(0.00197)
²⁰³ Tl	5279.86(12)	0.207(6)	0.00307(9)	139.94(0.400), 347.96(0.361), 318.88(0.325)
¹⁴ N	5297.821(15)	0.01680(23)	0.00363(5)	5269.159(0.0236), 5533.395(0.0155), 1884.821(0.01470)
¹⁸⁶ W	5320.72(6)	0.605(21)	0.0100(4)	685.73(3.24), 479.550(2.59), 72.002(1.32)
³⁹ K	5380.018(16)	0.146(4)	0.0113(3)	29.8300(1.380), 770.3050(0.903), 1158.887(0.1600)
²⁰³ Tl	5404.41(12)	0.147(5)	0.00218(7)	139.94(0.400), 347.96(0.361), 318.88(0.325)
³² S	5420.574(24)	0.308(7)	0.0291(7)	840.993(0.347), 2379.661(0.208), 3220.588(0.117)
²⁰³ Tl	5451.07(14)	0.079(3)	0.00117(4)	139.94(0.400), 347.96(0.361), 318.88(0.325)
⁶⁸ Zn	5474.02(10)	0.042(5)	0.00195(23)	1077.335(0.356), 115.225(0.167), 7863.55(0.1410)
⁹³ Nb	5496.24(10)	0.0205(14)	0.00067(5)	99.4070(0.196), 255.9290(0.176), 253.115(0.1320)
¹³³ Cs	5505.46(20)	0.333(22)	0.0076(5)	176.4040(2.47), 205.615(1.560), 510.795(1.54)
⁵¹ V	5515.813(23)	0.39(4)	0.0232(24)	1434.10(4.81), 125.082(1.61), 6517.282(0.78)
⁵⁵ Mn	5527.08(8)	0.788(22)	0.0435(12)	846.754(13.10), 1810.72(3.62), 26.560(3.42)
²⁰³ Tl	5533.35(13)	0.131(5)	0.00194(7)	139.94(0.400), 347.96(0.361), 318.88(0.325)
¹⁴ N	5533.395(14)	0.0155(8)	0.00335(15)	5269.159(0.0236), 5297.821(0.01680), 1884.821(0.01470)
⁷⁵ As	5533.94(3)	0.151(7)	0.0061(3)	559.10(2.00), 165.0490(0.996), 86.7880(0.579)
¹⁹¹ Ir	5534.73(12)	1.39(6)	0.0219(10)	351.689(10.9), 328.448(9.1), 84.2740(7.7)
¹⁹ F	5543.713(10)	0.000407(17)	6.5E-05(3)	1633.53(0.0096), 583.561(0.00356), 656.006(0.00197)
¹⁶⁴ Dy	5557.26(3)	28.7(14)	0.54(3)	184.257(146), 538.609(69.2), 496.931(44.9)
¹⁴ N	5562.057(13)	0.0084(5)	0.00182(11)	5269.159(0.0236), 5297.821(0.01680), 5533.395(0.0155)
¹⁹¹ Ir	5564.54(14)	1.71(8)	0.0270(13)	351.689(10.9), 328.448(9.1), 84.2740(7.7)
¹³³ Cs	5572.00(25)	0.249(20)	0.0057(5)	176.4040(2.47), 205.615(1.560), 510.795(1.54)
⁴⁰ Ar	5582.4(8)	0.077(8)	0.0058(6)	167.30(0.53), 4745.3(0.36), 1186.8(0.34)
⁷⁶ Se	5600.995(21)	0.301(14)	0.0116(5)	613.724(2.14), 238.9980(2.06), 520.6370(1.260)
⁷¹ Ga	5601.75(25)	0.063(4)	0.00274(17)	834.08(1.65), 2201.91(0.52), 629.96(0.490)
²⁰³ Tl	5603.28(13)	0.282(10)	0.00418(15)	139.94(0.400), 347.96(0.361), 318.88(0.325)
¹⁶⁴ Dy	5607.69(3)	35.9(16)	0.67(3)	184.257(146), 538.609(69.2), 496.931(44.9)
¹³³ Cs	5637.056(17)	0.277(21)	0.0063(5)	176.4040(2.47), 205.615(1.560), 510.795(1.54)
²⁰³ Tl	5641.57(12)	0.316(7)	0.00469(10)	139.94(0.400), 347.96(0.361), 318.88(0.325)
¹⁹⁹ Hg	5658.24(4)	27.5(7)	0.415(11)	367.947(251), 5967.02(62.5), 1693.296(56.2)
⁵⁹ Co	5660.93(4)	1.89(6)	0.097(3)	229.879(7.18), 277.161(6.77), 555.972(5.76)
¹⁴¹ Pr	5666.170(6)	0.379(15)	0.0082(3)	176.8630(1.06), 140.9050(0.479), 1575.6(0.426)
¹⁹¹ Ir	5667.81(3)	2.68(10)	0.0423(16)	351.689(10.9), 328.448(9.1), 84.2740(7.7)
¹⁹¹ Ir	5689.06(3)	1.73(7)	0.0273(11)	351.689(10.9), 328.448(9.1), 84.2740(7.7)
¹⁹⁷ Au	5710.52(10)	1.27(17)	0.020(3)	410.(94.), 214.9710(9.0), 247.5730(5.56)
³⁵ Cl	5715.244(21)	1.820(16)	0.1556(14)	1164.8650(8.91), 517.0730(7.58), 6110.842(6.59)
¹⁹³ Ir	5728.97(7)	1.15(5)	0.0181(8)	351.689(10.9), 328.448(9.1), 84.2740(7.7)
¹³⁷ Ba	5730.81(6)	0.0617(20)	0.00136(4)	1435.77(0.308), 627.29(0.294), 818.514(0.212)
¹⁶⁹ Tm	5731.36(11)	1.17(22)	0.021(4)	200.(8.72), 149.7180(7.11), 140.(5.96)
¹⁶⁹ Tm	5737.51(11)	1.42(7)	0.0255(13)	200.(8.72), 149.7180(7.11), 140.(5.96)
⁵⁹ Co	5742.53(4)	0.766(23)	0.0394(12)	229.879(7.18), 277.161(6.77), 555.972(5.76)
⁵¹ V	5752.064(22)	0.366(24)	0.0218(14)	1434.10(4.81), 125.082(1.61), 6517.282(0.78)
¹⁹¹ Ir	5783.01(3)	1.34(6)	0.0211(10)	351.689(10.9), 328.448(9.1), 84.2740(7.7)
¹⁴¹ Pr	5843.026(5)	0.147(6)	0.00316(13)	176.8630(1.06), 140.9050(0.479), 1575.6(0.426)
²⁰³ Tl	5917.48(16)	0.084(4)	0.00125(6)	139.94(0.400), 347.96(0.361), 318.88(0.325)
⁵⁵ Mn	5920.39(8)	1.06(3)	0.0585(17)	846.754(13.10), 1810.72(3.62), 26.560(3.42)
⁵⁶ Fe	5920.449(21)	0.225(5)	0.0122(3)	7631.136(0.653), 7645.5450(0.549), 352.347(0.273)
¹⁶⁹ Tm	5941.47(11)	1.51(7)	0.0271(13)	200.(8.72), 149.7180(7.11), 140.(5.96)
¹⁶⁹ Tm	5943.09(11)	1.03(20)	0.018(4)	200.(8.72), 149.7180(7.11), 140.(5.96)
¹⁹¹ Ir	5958.28(3)	1.79(8)	0.0282(13)	351.689(10.9), 328.448(9.1), 84.2740(7.7)
¹⁹⁹ Hg	5967.02(4)	62.5(15)	0.944(23)	367.947(251), 1693.296(56.2), 4739.43(30.1)
⁵⁹ Co	5975.98(4)	2.9(4)	0.149(21)	229.879(7.18), 277.161(6.77), 555.972(5.76)
¹⁶⁹ Tm	6001.61(11)	0.99(10)	0.0178(18)	200.(8.72), 149.7180(7.11), 140.(5.96)
⁷⁶ Se	6006.973(21)	0.289(20)	0.0111(8)	613.724(2.14), 238.9980(2.06), 520.6370(1.260)
⁷¹ Ga	6007.25(14)	0.069(5)	0.00300(22)	834.08(1.65), 2201.91(0.52), 629.96(0.490)
¹⁹ F	6016.802(16)	0.00094(4)	1.50E-04(6)	1633.53(0.0096), 583.561(0.00356), 656.006(0.00197)
⁵⁶ Fe	6018.532(20)	0.227(5)	0.0123(3)	7631.136(0.653), 7645.5450(0.549), 352.347(0.273)
⁸⁹ Y	6080.171(22)	0.76(4)	0.0259(14)	776.613(0.659), 202.53(0.289), 574.106(0.174)
¹⁹¹ Ir	6082.48(3)	2.62(11)	0.0413(17)	351.689(10.9), 328.448(9.1), 84.2740(7.7)
³⁵ Cl	6110.842(18)	6.59(6)	0.563(5)	1164.8650(8.91), 517.0730(7.58), 1951.1400(6.33)
⁷¹ Ga	6111.72(24)	0.055(4)	0.00239(17)	834.08(1.65), 2201.91(0.52), 629.96(0.490)
¹⁸² W	6144.28(3)	0.174(11)	0.00287(18)	685.73(3.24), 479.550(2.59), 72.002(1.32)

^A Z	E γ -keV	$\sigma_{\gamma}^z(E_{\gamma})$ -barns	k ₀	E γ , $\sigma_{\gamma}^z(E_{\gamma})$ for associated intense gamma rays
²⁰³ Tl	6166.61(14)	0.166(6)	0.00246(9)	139.94(0.400), 347.96(0.361), 318.88(0.325)
¹³³ Cs	6175.412(17)	0.252(16)	0.0057(4)	176.4040(2.47), 205.615(1.560), 510.795(1.54)
²⁰³ Tl	6183.05(15)	0.081(4)	0.00120(6)	139.94(0.400), 347.96(0.361), 318.88(0.325)
¹⁸² W	6190.78(3)	0.45(4)	0.0074(7)	685.73(3.24), 479.550(2.59), 72.002(1.32)
¹⁵⁹ Tb	6218.56(7)	0.190(22)	0.0036(4)	75.0500(1.78), 63.6860(1.46), 64.1100(1.2)
²⁰³ Tl	6222.57(16)	0.065(4)	0.00096(6)	139.94(0.400), 347.96(0.361), 318.88(0.325)
⁹¹ Zr	6295.13(16)	0.0279(20)	0.00093(7)	934.4640(0.125), 1465.7(0.063), 1205.6(0.042)
¹⁴ N	6322.428(12)	0.01450(22)	0.00314(5)	5269.159(0.0236), 5297.821(0.01680), 5533.395(0.0155)
⁷¹ Ga	6358.61(14)	0.138(5)	0.00600(22)	834.08(1.65), 2201.91(0.52), 629.96(0.490)
²⁸ Si	6379.801(21)	0.0207(6)	0.00223(7)	3538.966(0.1190), 4933.889(0.1120), 2092.902(0.0331)
¹⁶⁹ Tm	6387.37(11)	1.48(7)	0.0265(13)	200.(8.72), 149.7180(7.11), 140.(5.96)
²³ Na	6395.478(15)	0.1000(20)	0.0132(3)	1368.66(0.530), 2754.13(0.530), 472.202(0.478)
⁴⁸ Ti	6418.426(14)	1.96(6)	0.124(4)	1381.745(5.18), 6760.084(2.97), 341.706(1.840)
⁴⁰ Ca	6419.59(5)	0.176(5)	0.0133(4)	1942.67(0.352), 4418.52(0.0708), 2001.31(0.0659)
⁵¹ V	6464.887(18)	0.43(4)	0.0256(24)	1434.10(4.81), 125.082(1.61), 6517.282(0.78)
¹³¹ Xe	6467.09(12)	1.33(19)	0.031(4)	667.79(6.7), 772.72(1.78), 536.17(1.71)
⁵⁹ Co	6485.99(3)	2.32(5)	0.119(3)	229.879(7.18), 277.161(6.77), 555.972(5.76)
²⁰³ Tl	6514.57(15)	0.129(5)	0.00191(7)	139.94(0.400), 347.96(0.361), 318.88(0.325)
⁵¹ V	6517.282(19)	0.78(4)	0.0464(24)	1434.10(4.81), 125.082(1.61), 645.703(0.769)
¹²¹ Sb	6523.52(7)	0.075(3)	0.00187(8)	564.24(2.700), 61.4130(0.75), 78.0910(0.48)
¹⁹ F	6600.175(16)	0.00096(3)	1.53E-04(5)	1633.53(0.0096), 583.561(0.00356), 656.006(0.00197)
⁷⁶ Se	6600.690(21)	0.623(20)	0.0239(8)	613.724(2.14), 238.9980(2.06), 520.6370(1.260)
³⁵ Cl	6619.615(19)	2.530(23)	0.2163(20)	1164.8650(8.91), 517.0730(7.58), 6110.842(6.59)
³⁵ Cl	6627.821(18)	1.470(16)	0.1257(14)	1164.8650(8.91), 517.0730(7.58), 6110.842(6.59)
⁵³ Cr	6645.61(8)	0.183(13)	0.0107(8)	834.849(1.38), 8884.36(0.78), 749.09(0.569)
⁵⁹ Co	6706.01(3)	3.02(6)	0.155(3)	229.879(7.18), 277.161(6.77), 555.972(5.76)
¹⁵⁷ Gd	6750.11(5)	965(30)	18.6(6)	181.931(7200), 79.5100(4010), 944.174(3090)
⁴⁸ Ti	6760.084(14)	2.97(9)	0.188(6)	1381.745(5.18), 6418.426(1.96), 341.706(1.840)
⁵⁵ Mn	6783.74(12)	0.378(17)	0.0209(9)	846.754(13.10), 1810.72(3.62), 26.560(3.42)
³¹ P	6785.504(24)	0.0267(15)	0.00261(15)	512.646(0.079), 78.083(0.059), 636.663(0.0311)
⁷⁵ As	6808.872(8)	0.160(8)	0.0065(3)	559.10(2.00), 165.0490(0.996), 86.7880(0.579)
⁹ Be	6809.61(3)	0.0058(5)	0.00195(17)	3367.448(0.00285), 853.630(0.00208), 2590.014(0.00191)
⁷⁵ As	6810.898(8)	0.56(3)	0.0227(12)	559.10(2.00), 165.0490(0.996), 86.7880(0.579)
⁶² Ni	6837.50(3)	0.458(8)	0.0236(4)	8998.414(1.49), 464.978(0.843), 8533.509(0.721)
⁴⁵ Sc	6839.09(4)	0.95(4)	0.064(3)	227.773(7.13), 147.011(6.08), 142.528(4.88)
⁴⁵ Sc	6840.34(4)	0.76(11)	0.051(7)	227.773(7.13), 147.011(6.08), 142.528(4.88)
⁵¹ V	6874.157(19)	0.49(6)	0.029(4)	1434.10(4.81), 125.082(1.61), 6517.282(0.78)
⁵⁹ Co	6877.16(3)	3.02(6)	0.155(3)	229.879(7.18), 277.161(6.77), 555.972(5.76)
⁶⁶ Zn	6958.8(3)	0.043(3)	0.00199(14)	1077.335(0.356), 115.225(0.167), 7863.55(0.1410)
⁵⁹ Co	6985.41(3)	1.05(13)	0.054(7)	229.879(7.18), 277.161(6.77), 555.972(5.76)
⁶³ Cu	6988.68(5)	0.126(6)	0.0060(3)	278.250(0.893), 7915.62(0.869), 159.281(0.648)
⁷⁵ As	7020.139(8)	0.104(7)	0.0042(3)	559.10(2.00), 165.0490(0.996), 86.7880(0.579)
⁵⁵ Mn	7057.89(9)	1.22(3)	0.0673(17)	846.754(13.10), 1810.72(3.62), 26.560(3.42)
⁵³ Cr	7099.91(6)	0.146(9)	0.0085(5)	834.849(1.38), 8884.36(0.78), 749.09(0.569)
⁵⁵ Mn	7159.63(10)	0.643(24)	0.0355(13)	846.754(13.10), 1810.72(3.62), 26.560(3.42)
⁵¹ V	7162.898(15)	0.59(4)	0.0351(24)	1434.10(4.81), 125.082(1.61), 6517.282(0.78)
⁶³ Cu	7176.68(5)	0.0925(17)	0.00441(8)	278.250(0.893), 7915.62(0.869), 159.281(0.648)
⁷⁶ Se	7179.492(21)	0.261(25)	0.0100(10)	613.724(2.14), 238.9980(2.06), 520.6370(1.260)
²⁸ Si	7199.199(23)	0.0125(4)	0.00135(4)	3538.966(0.1190), 4933.889(0.1120), 2092.902(0.0331)
⁵⁹ Co	7214.42(3)	1.38(3)	0.0710(15)	229.879(7.18), 277.161(6.77), 555.972(5.76)
⁵⁵ Mn	7243.52(9)	1.36(3)	0.0750(17)	846.754(13.10), 1810.72(3.62), 26.560(3.42)
⁶³ Cu	7253.01(5)	0.1500(23)	0.00715(11)	278.250(0.893), 7915.62(0.869), 159.281(0.648)
⁵⁵ Mn	7270.14(12)	0.362(15)	0.0200(8)	846.754(13.10), 1810.72(3.62), 26.560(3.42)
⁵⁶ Fe	7278.838(10)	0.137(4)	0.00743(22)	7631.136(0.653), 7645.5450(0.549), 352.347(0.273)
¹⁴ N	7298.983(17)	0.00746(12)	0.00161(3)	5269.159(0.0236), 5297.821(0.01680), 5533.395(0.0155)
⁶³ Cu	7306.93(4)	0.321(17)	0.0153(8)	278.250(0.893), 7915.62(0.869), 159.281(0.648)
⁵¹ V	7310.721(15)	0.227(9)	0.0135(5)	1434.10(4.81), 125.082(1.61), 6517.282(0.78)
²⁰⁷ Pb	7367.78(7)	0.137(3)	0.00200(4)	
³⁵ Cl	7413.968(18)	3.29(5)	0.281(4)	1164.8650(8.91), 517.0730(7.58), 6110.842(6.59)
⁷⁶ Se	7418.467(21)	0.350(13)	0.0134(5)	613.724(2.14), 238.9980(2.06), 520.6370(1.260)
³¹ P	7422.022(25)	0.0082(3)	0.00080(3)	512.646(0.079), 78.083(0.059), 636.663(0.0311)
⁵⁹ Co	7491.54(3)	1.16(3)	0.0596(15)	229.879(7.18), 277.161(6.77), 555.972(5.76)
⁶⁰ Ni	7536.637(25)	0.190(4)	0.00981(21)	8998.414(1.49), 464.978(0.843), 8533.509(0.721)
⁷⁹ Br	7577.04(8)	0.108(3)	0.00410(11)	776.517(0.990), 554.3480(0.838), 245.203(0.80)
⁸⁵ Rb	7624.07(11)	0.0114(5)	0.000404(18)	556.82(0.0913), 487.89(0.0494), 555.61(0.0407)
⁵⁶ Fe	7631.136(14)	0.653(13)	0.0354(7)	7645.5450(0.549), 352.347(0.273), 6018.532(0.227)
⁶³ Cu	7637.40(4)	0.54(7)	0.026(3)	278.250(0.893), 7915.62(0.869), 159.281(0.648)
⁵⁶ Fe	7645.5450(10)	0.549(11)	0.0298(6)	7631.136(0.653), 352.347(0.273), 6018.532(0.227)
²⁷ Al	7693.397(4)	0.0081(3)	0.00091(3)	1778.92(0.232), 30.6380(0.0798), 7724.027(0.0493)

^A Z	E γ -keV	$\sigma_{\gamma}^z(E_{\gamma})$ -barns	k ₀	E γ , $\sigma_{\gamma}^z(E_{\gamma})$ for associated intense gamma rays
²⁷ Al	7724.027(4)	0.0493(15)	0.00554(17)	1778.92(0.232), 30.6380(0.0798), 3033.896(0.0179)
³⁵ Cl	7790.330(18)	2.66(3)	0.227(3)	1164.8650(8.91), 517.0730(7.58), 6110.842(6.59)
⁶⁰ Ni	7819.517(21)	0.336(6)	0.0173(3)	8998.414(1.49), 464.978(0.843), 8533.509(0.721)
⁶⁴ Zn	7863.55(7)	0.1410(19)	0.00653(9)	1077.335(0.356), 115.225(0.167), 1883.12(0.0718)
⁶³ Cu	7915.62(4)	0.869(20)	0.0414(10)	278.250(0.893), 159.281(0.648), 7637.40(0.54)
⁵² Cr	7938.46(23)	0.424(11)	0.0247(6)	834.849(1.38), 8884.36(0.78), 749.09(0.569)
⁴⁵ Sc	8175.176(21)	1.80(6)	0.121(4)	227.773(7.13), 147.011(6.08), 142.528(4.88)
¹⁴ N	8310.161(19)	0.00330(6)	0.000714(13)	5269.159(0.0236), 5297.821(0.01680), 5533.395(0.0155)
⁵⁰ Cr	8482.80(9)	0.169(7)	0.0098(4)	834.849(1.38), 8884.36(0.78), 749.09(0.569)
⁵⁰ Cr	8510.77(8)	0.233(8)	0.0136(5)	834.849(1.38), 8884.36(0.78), 749.09(0.569)
⁴⁵ Sc	8532.122(20)	0.89(4)	0.060(3)	227.773(7.13), 147.011(6.08), 142.528(4.88)
⁵⁸ Ni	8533.509(17)	0.721(13)	0.0372(7)	8998.414(1.49), 464.978(0.843), 6837.50(0.458)
⁵³ Cr	8884.36(5)	0.78(5)	0.045(3)	834.849(1.38), 749.09(0.569), 7938.46(0.424)
⁵⁸ Ni	8998.414(15)	1.49(3)	0.0769(15)	464.978(0.843), 8533.509(0.721), 6837.50(0.458)
⁵⁴ Fe	9297.68(19)	0.0747(25)	0.00405(14)	7631.136(0.653), 7645.5450(0.549), 352.347(0.273)
⁵³ Cr	9719.06(5)	0.260(18)	0.0152(10)	834.849(1.38), 8884.36(0.78), 749.09(0.569)
⁷⁷ Se	9883.35(3)	0.220(22)	0.0084(8)	613.724(2.14), 238.9980(2.06), 520.6370(1.260)
¹⁴ N	10829.120(12)	0.0113(8)	0.00244(17)	5269.159(0.0236), 5297.821(0.01680), 5533.395(0.0155)
³ He	20520.46	4.2E-11(12)	3.2E-11(9)	

8. PGAA-IAEA Database: CD-ROM

R.B. Firestone, V. Zerkin

Both the database of prompt gamma-rays from slow neutron capture for elemental analysis and the results of this Co-ordinated Research Project are available on the accompanying CD-ROM. The file *index.html* is the Home Page for the CD-ROM, and provides links to the following information.

- CRP** – general information, papers and reports relevant to this Coordinated Research Project.
- PGAA-IAEA Database Viewer** – interactive program to display and search the PGAA database by isotope, energy, or capture cross section.
- Database of Prompt Gamma Rays from Slow Neutron Capture for Elemental Analysis** – this report.
- PGAA Database Files** - Adopted PGAA database and associated files in EXCEL, PDF and TEXT formats. The archival databases by Lone *et al.* [8.1] and by Reedy and Frankle (LANL) [8.2, 8.3] are also available.
- Evaluated Gamma-ray Activation File (EGAF)** - Adopted PGAA database in ENSDF format. Data can be viewed with Isotope Explorer 2.2 ENSDF Viewer (see below).
- PGAA Database Evaluation** – ENSDF-format versions of the adopted PGAA database, and the Budapest and ENSDF isotopic input files. Decay scheme balance and statistical analysis summaries are provided.
- Isotope Explorer 2.2 ENSDF Viewer** - Windows software for viewing the level scheme drawings and tables provided in ENSDF format. The complete ENSDF database is included, as of December 2002.

The databases and viewers are discussed in greater detail in the following sections.

8.1. PGAA-IAEA Database Viewer

PGAA: Elements and Isotopes

<i>Selected Element</i> 17-Chlorine (457) Cl-35 (386) Cl-37 (71)		1																	2		
		<u>H</u>																	<u>He</u>		
		3	4													5	6	7	8	9	10
		<u>Li</u>	<u>Be</u>													<u>B</u>	<u>C</u>	<u>N</u>	<u>O</u>	<u>F</u>	<u>Ne</u>
11	12													13	14	15	16	17	18		
<u>Na</u>	<u>Mg</u>													<u>Al</u>	<u>Si</u>	<u>P</u>	<u>S</u>	<u>Cl</u>	<u>Ar</u>		
19	20	21	22	23	24	25	26	27	28	29	30	31	32	33	34	35	36				
<u>K</u>	<u>Ca</u>	<u>Sc</u>	<u>Ti</u>	<u>V</u>	<u>Cr</u>	<u>Mn</u>	<u>Fe</u>	<u>Co</u>	<u>Ni</u>	<u>Cu</u>	<u>Zn</u>	<u>Ga</u>	<u>Ge</u>	<u>As</u>	<u>Se</u>	<u>Br</u>	<u>Kr</u>				
37	38	39	40	41	42	43	44	45	46	47	48	49	50	51	52	53	54				
<u>Rb</u>	<u>Sr</u>	<u>Y</u>	<u>Zr</u>	<u>Nb</u>	<u>Mo</u>	Tc	<u>Ru</u>	<u>Rh</u>	<u>Pd</u>	<u>Ag</u>	<u>Cd</u>	<u>In</u>	<u>Sn</u>	<u>Sb</u>	<u>Te</u>	<u>I</u>	<u>Xe</u>				
55	56	57*	72	73	74	75	76	77	78	79	80	81	82	83	84	85	86				
<u>Cs</u>	<u>Ba</u>	<u>La</u>	<u>Hf</u>	<u>Ta</u>	<u>W</u>	<u>Re</u>	<u>Os</u>	<u>Ir</u>	<u>Pt</u>	<u>Au</u>	<u>Hg</u>	<u>Tl</u>	<u>Pb</u>	<u>Bi</u>	Po	At	Rn				
87	88	89**	104	105	106	107	108	109	110	111	112										
Fr	Ra	Ac	Rf	Db	Sg	Bh	Hs	Mt	*	*	*										
* Lanthanides			58	59	60	61	62	63	64	65	66	67	68	69	70	71					
			<u>Ce</u>	<u>Pr</u>	<u>Nd</u>	Pm	<u>Sm</u>	<u>Eu</u>	<u>Gd</u>	<u>Tb</u>	<u>Dy</u>	<u>Ho</u>	<u>Er</u>	<u>Tm</u>	<u>Yb</u>	<u>Lu</u>					
** Actinides			90	91	92	93	94	95	96	97	98	99	100	101	102	103					
			<u>Th</u>	Pa	<u>U</u>	Np	Pu	Am	Cm	Bk	Cf	Es	Fm	Md	No	Lr					

FIG. 8.1 Periodic table of elements and isotopes displayed by the PGAA-IAEA Viewer.

The PGAA-IAEA Database Viewer is provided on this CD-ROM, and was developed by Zarkin (IAEA, NDS). This Viewer is also available on the Internet from the Nuclear Data Service of the International Atomic Energy Agency: <http://www-nds.iaea.org>, and contains html-pages with large portions of JavaScript and GIF-plots for the gamma emissions of each isotope. Such a design enables the Viewer to be used on many platforms with standard Web-browsers. The Viewer also includes interactive plotting provided with the ZVView program, which can be used as a helper-application. ZVView for Windows and Linux are included in the CD-ROM.

Target: 17-Chlorine

Atomic weight (amu) = 35.4527(9)

Elemental Cross Section (barns) = 33.1(3)

Isotope	Abundance (%)	Isotopic Cross Section (barns)	g-factor	N gammas
Cl-35	75.78(4)	43.6(4)	1	386
Cl-37	24.22(4)	0.433(6)	1	71

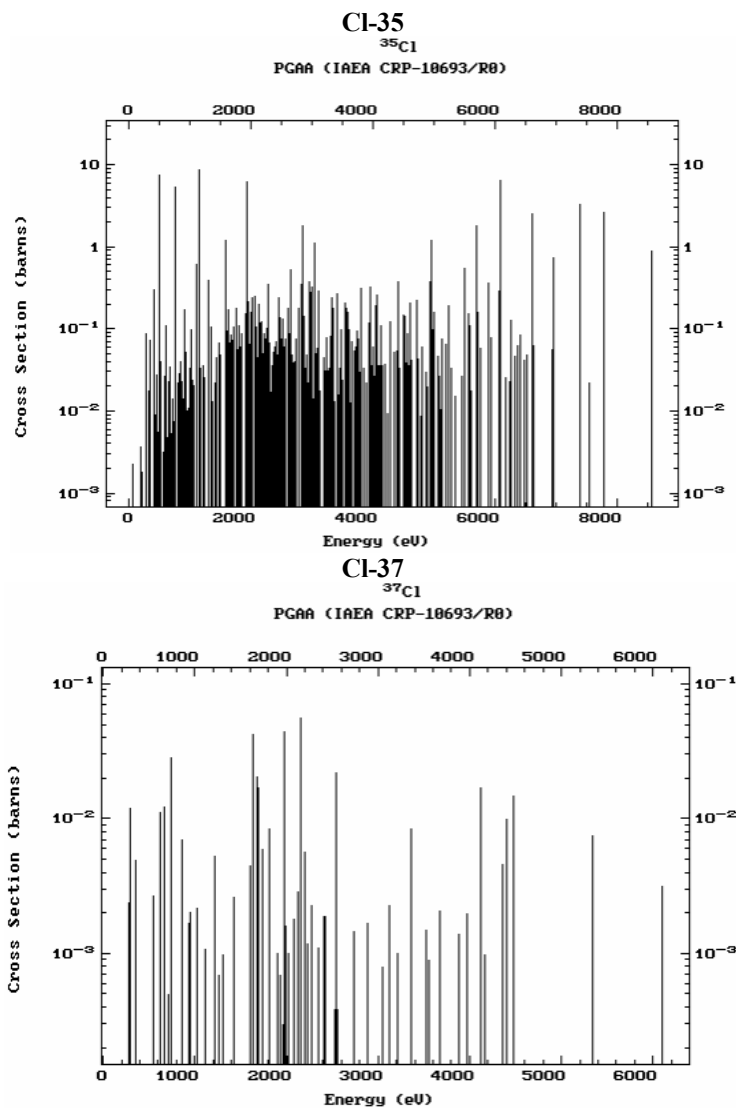

FIG. 8.2 Isotopic and elemental data, and histograms of gamma-ray energies and intensities displayed with the PGAA-IAEA Viewer.

The Viewer can be opened in standard mode to view the database, or in advanced mode to search the database. Fig. 8.1 shows a periodic table of the PGAA elements, as obtained when the Viewer is opened.

Clicking with the mouse on an element in the periodic table displays the isotopes of that element and the number of prompt gamma rays in the database for each isotope. A new window is also opened, as shown in Fig. 8.2, that displays the isotopic and elemental data and histograms of the gamma-ray energies and intensities.

Clicking on an isotope in the selected element box (square on the left) opens a table of gamma-ray energies, cross sections, prompt or decay type, and k_0 values as shown in Fig. 8.3.

Target: 17-Chlorine-35
 Isotopic Abundance(%): 75.78(4)
 Isotopic Capture Cross Section (barns): 43.6(4)
 Number of Gammas: 386
 Westcott g-factor: 1
Sigma(b): Partial gamma ray production cross section (barns)
 p - Prompt, d - Delayed, S – Stable

#	<i>E</i> (keV)	<i>Sigma</i> (b)	Type	Half-life	k_0
1	85.747(9)	2.3e-3(5)	p	Stable	6.9e-3(15)
2	204.380(8)	3.7e-3(8)	p	Stable	0.0111(24)
3	225.49(7)	1.58e-3(6)	p	Stable	4.74e-3(18)
4	225.89(5)	1.1e-3(5)	p	Stable	3.3e-3(15)
5	236.775(13)	1.8e-3(6)	p	Stable	5.4e-3(18)
6	292.177(8)	0.0893(10)	p	Stable	0.268(3)
7	302.64(4)	2.1e-3(11)	p	Stable	6e-3(3)
8	337.620(11)	0.018(6)	p	Stable	0.054(18)
9	342.314(7)	5.4e-3(9)	p	Stable	0.016(3)
10	358.291(6)	0.0736(20)	p	Stable	0.221(6)
11	369(4)	0.019(5)	p	Stable	0.057(15)
12	371.3(25)	1.4e-3(3)	p	Stable	4.2e-3(9)
13	376.4460(20)	1.3e-3(3)	p	Stable	3.9e-3(9)
14	427.89(10)	9.9e-3(16)	p	Stable	3e-2(5)
15	428.060(8)	3.9e-3(7)	p	Stable	0.0117(21)
16	435.964(13)	0.051(8)	p	Stable	0.153(24)
17	436.222(4)	0.309(20)	p	Stable	0.928(6)
18	455.58(11)	4.3e-3(21)	p	Stable	0.013(6)
19	459.46(8)	9e-3(3)	p	Stable	0.027(9)
20	463.72(4)	2e-3(16)	p	Stable	6e-3(5)
21	464.8(5)	4e-3(3)	p	Stable	0.012(9)
22	465.9(11)	5e-3(15)	p	Stable	0.015(5)
23	466.63(15)	1e-2(5)	p	Stable	3e-2(15)
24	468.359(7)	0.0274(20)	p	Stable	0.082(6)
25	478.4(25)	0.027(15)	p	Stable	8e-2(5)

FIG. 8.3 Display of partial table of gamma-ray energies, cross sections, prompt or decay type, and k_0 value (complete table contains 386 gamma rays).

As advanced retrieval mode is available in which the Viewer displays a gamma-ray search window as shown in Fig. 8.4. There are two options in this mode: retrieve the whole database (about 35 000 lines) or a reduced version (about 1300 gamma lines). The reduced version contains lines that are up to 10% of the most intense gamma-ray emission for each element, but at least one gamma-ray emission for each isotope independent of the intensity.

The result of the search shown in Fig. 8.4 for gamma rays between 3000 and 3002 keV is displayed in a new window as shown in Fig. 8.5. PGAA databases can also be downloaded in text format from the PGAA-IAEA Viewer.

Gamma-Ray Search

	Energy (keV)	Z	A	CS
<i>From</i>	<input checked="" type="checkbox"/> 3000	<input type="checkbox"/> 20	<input type="checkbox"/> 43	<input type="checkbox"/> 1e-4
<i>To</i>	<input checked="" type="checkbox"/> 3002	<input type="checkbox"/> 30	<input type="checkbox"/> 44	<input type="checkbox"/> 1e-3

Type: All Prompt Delayed

Sort by: Energy Cross Section

Fig. 8.4 Gamma-ray search window: data can be selected from the entire database by energy, atomic number, mass number, delayed or prompt type, and/or cross section, and the results can be sorted by energy or cross section.

PGAA -

n	Energy, keV	Isotope	Sigma, b	Type	Half-life	k_0
1	3001.07 (5)	Cl-35	0.216 (7)	p	S	0.649 (21)
2	3001.17 (13)	La-139	2.2e-3 (23)	p	S	6.6e-3 (7)
3	3001.55 (5)	K-40 1	1.3e-5 (3)	p	S	3.9e-5 (9)
4	3001.89 (15)	Ca-40	7.3e-4 (19)	p	S	2.2e-3 (6)
5	3001.97 (13)	Sc-45	0.043 (12)	p	S	0.13 (4)

p - prompt, d - delayed, S - stable

FIG.8.5 Display of results of a search for gamma rays with $E = 3000 - 3002$ keV.

8.2. PGAA data files

The PGAA database and associated files are provided in various formats. Microsoft EXCEL format files include elemental data (atomic weights and elemental cross sections), isotopic data (abundances, cross sections and g-factors), and gamma-ray data (energies, cross sections and k_0 values). Tables of isotopic data, decay parent data, gamma-ray lists, g-factors and references from this document are provided in Adobe Portable Document Format and PostScript. Energies and cross sections for adopted prompt and decay gamma rays, and input ENSDF and Budapest gamma rays are available in text format.

8.3. Evaluated Gamma-ray Activation File (EGAF)

The Evaluated Gamma-ray Activation File (EGAF) contains the recommended PGAA database in ENSDF format. The nuclear structure information associated with these data is also preserved, along with three neutron-capture gamma-ray datasets: adopted PGAA, Budapest PGAA and LANL data [8.2, 8.3]. EGAF can be viewed by means of the Isotope Explorer 2.2 ENSDF Viewer (see below).

8.4. PGAA database evaluation

Selecting an element in the HTML periodic table provides a detailed summary of the evaluation. The atomic abundances and Mughabghab *et al.* cross sections are given for each isotope [8.4-8.6]. All Budapest and ENSDF input databases and the final adopted data are provided in ENSDF format. A summary of the initial matching of the Budapest data to the ENSDF data is given as a text file for determining isotopic assignments. This file contains all of the gamma rays measured at Budapest, and was subsequently edited to select only those gamma rays that could be reliably placed in a known level scheme. Additional text files show the least-squares energy and intensity fits, and decay-scheme intensity balance for all relevant datasets. Summary HTML tables are provided that compare the adopted, ENSDF, Budapest, Reedy and Frankle [8.2, 8.3], and Lone *et al.* [8.1].

The total cross section is presented, as deduced from the total measured gamma-ray intensity feeding the ground state and/or de-exciting the capture state. This parameter can also be deduced in some cases from the gamma-ray intensity of short-lived radioisotopes. If the decay scheme is dominated by continuum or unobserved gamma rays that populate the ground state, this cross section should be considered to be a lower limit. The agreement between Mughabghab [8.4] and the current measurements was excellent in a good many cases. Data that exceed the Mughabghab values may indicate that the adopted values are too low, particularly when the overall intensity balances are correct. The new cross section results should be taken as a guide to the overall quality of the data; we do not recommend that these values be quoted until further analysis can be performed.

8.5. Isotope Explorer 2.2, ENSDF Viewer

Isotope Explorer 2.2 by Firestone and Chu (Lawrence Berkeley National Laboratory, USA) and Ekström (Lund University, Sweden) can be installed on Windows PC computers to display level scheme drawings and tables from the data provided in ENSDF format. A “tour” of Isotope Explorer’s capabilities is provided, as shown in Fig. 8.6. Links are available to download and install the program, and a detailed user manual is included. The program is installed by going to the download link, clicking on the self-extracting program archive IE223.EXE (50 MB), choosing “OPEN”, and extracting the program and files to the selected directory. The application can be run from this directory or a short cut can be created on the extension .ENS is used for the PGAA ENSDF data. Associating this extension with Isotope Explorer in the PC will allow direct runs when opening the file. The ENSDF format files can also be read with a text editor, and the ENSDF format manual is provided.

When running Isotope Explorer directly from the executable, the user is prompted to select an isotope. The program can be configured to select data from a local or Internet database. A copy of the complete ENSDF file is included on the CD-ROM, which can be downloaded from the installation menu and used as the local database.



Tour of Isotope Explorer

Version 2.23:

Transfer and installation
User's manual
ENSDF manual
Sample nuclear charts

Isotope Explorer

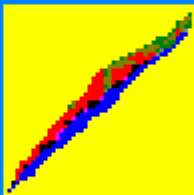

Isotope Explorer

"Nuclear data a mouse-click away"

S Y F Chu*, L P Ekström# and R B Firestone*

** Isotopes Project, LBNL, Berkeley*
Department of Physics, Lund University

Isotope Explorer is a Windows application to interactively access and display nuclear data and to search for literature references. Isotope Explorer can retrieve data via the Internet or it can use data stored locally.

The program can display **level drawings, coincidences, tables, band plots, nuclear charts, chart data** and literature **references** - see figures on the left.

Isotope Explorer supports a **nuclear chart interface**, it can display systematics of nuclear properties by color coding a nuclear chart, and it can perform complex searches and calculations with the built-in **script language**.

FIG. 8.6 Tour of Isotope Explorer 2.2.

The user can open an ENSDF file directly from the Isotope Explorer file menu. Fig. 8.7 shows an example of a level scheme display for the $^{24}\text{Mg}(n, \gamma)$ reaction. Only the lowest tier of gamma rays is shown, and the user must scroll through the display to see gamma rays from the capture state. Different displays can be chosen with the Addview menu. A tabular display is shown in Fig. 8.8. Other features including plots and chart generation are described in the Isotope Explorer manual.

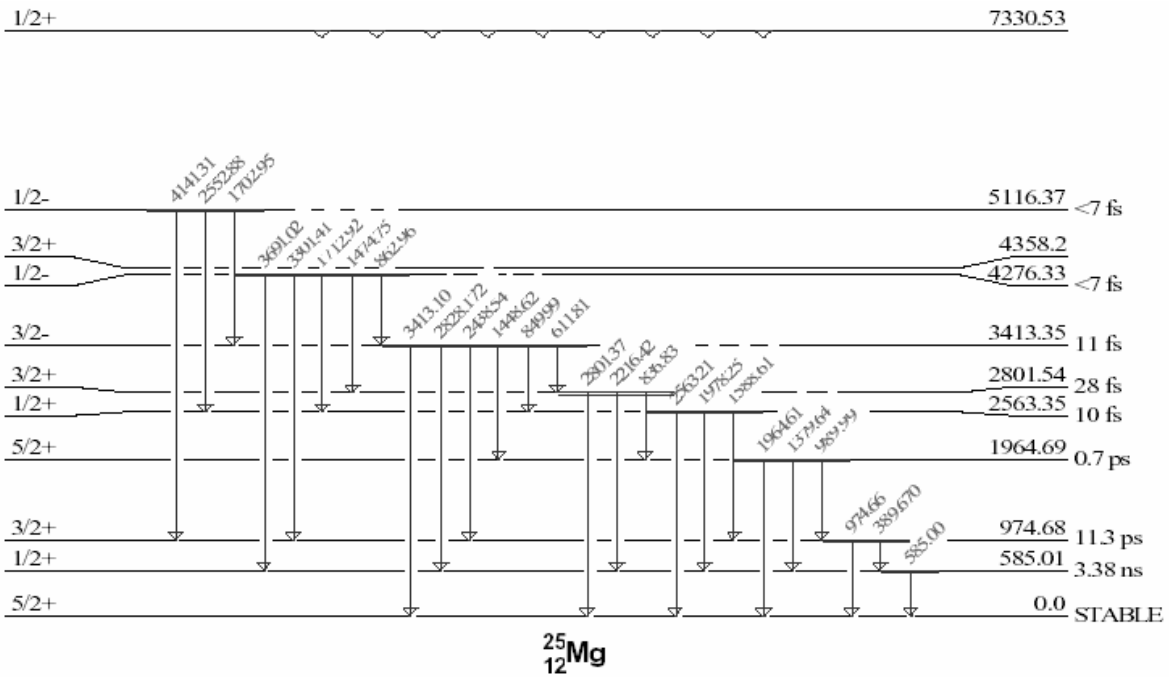

FIG. 8.7 Level scheme displayed with Isotope Explorer: gamma rays are displayed in tiers that can be scrolled through.

Gammas for $^{25}\text{Mg}; ^{24}\text{Mg}(n,\gamma)$ E=thermal

General Comments

SIGMAN=0.051 5 (1981MUZQ)

I_γ Normalization: NORMALIZATION FROM 1992WA06.

E_γ	E_{level}	$J\pi_i$	$J\pi_f$	Mult \ddagger	$\delta\ddagger$	I_γ^\dagger	$T_{1/2}$
389.670 21	974.68 3	3/2+	1/2+	M1+E2	+0.13 3	0.00586 24	11.3 ps 3
585.00 3	585.01 3	1/2+	5/2+	E2(+M3)	=0	0.0314 11	3.38 ns 5
611.81 9	3413.35 3	3/2-	3/2+			1.2×10^{-5} 12	11 fs 4
836.83 6	2801.54 9	3/2+	5/2+	M1(+E2)	-0.03 3	1.58×10^{-4} 15	28 fs 7
849.99 4	3413.35 3	3/2-	1/2+			6.6×10^{-5} 11	11 fs 4
862.96 3	4276.33 4	1/2-	3/2-	[M1]		0.000410 21	<7 fs
974.66 3	974.68 3	3/2+	5/2+	M1+E2	+0.36 2	0.00663 24	11.3 ps 3
989.99 10	1964.69 10	5/2+	3/2+	M1+E2	-0.25 2	3.9×10^{-5} 8	0.7 ps 3
1379.64 9	1964.69 10	5/2+	1/2+	E2(+M3)	=0	8.4×10^{-5} 11	0.7 ps 3
1448.62 10	3413.35 3	3/2-	5/2+			1.2×10^{-5} 12	11 fs 4
1474.75 10	4276.33 4	1/2-	3/2+			1.2×10^{-5} 12	<7 fs
1588.61 4	2563.35 4	1/2+	3/2+			0.000250 23	10 fs 3
1702.95 15	5116.37 15	1/2-	3/2-	M1+E2	+0.09 7	3.2×10^{-5} 10	<7 fs
1712.92 4	4276.33 4	1/2-	1/2+	E1		0.00118 7	<7 fs
1964.61 10	1964.69 10	5/2+	5/2+	M1+E2	-0.60 10	8.1×10^{-5} 18	0.7 ps 3
1978.25 3	2563.35 4	1/2+	1/2+	M1		0.00111 5	10 fs 3
2214.06 15	7330.53 4	1/2+	1/2-	[E1]		0.00030 3	
2216.42 9	2801.54 9	3/2+	1/2+			1.9×10^{-4} 3	28 fs 7
2438.54 3	3413.35 3	3/2-	3/2+	E1(+M2)	=0	0.00473 19	11 fs 4
2552.88 15	5116.37 15	1/2-	1/2+	M1(+E2)	-0.19 9	2.4×10^{-5} 9	<7 fs
2563.21 4	2563.35 4	1/2+	5/2+	[E2]		5.5×10^{-5} 16	10 fs 3
2801.37 9	2801.54 9	3/2+	5/2+	M1+E2	-0.64 8	1.31×10^{-4} 16	28 fs 7
2828.172 25	3413.35 3	3/2-	1/2+	E1(+M2)	=0	0.0240 8	11 fs 4

FIG. 8.8 Display of gamma-ray data as listed by Isotope Explorer.

REFERENCES

- [8.1] LONE, M.A., LEAVITT, R.A., HARRISON, D.A., Prompt Gamma Rays from Thermal-neutron Capture, *At. Data Nucl. Data Tables* **26** (1981) 511.
- [8.2] REEDY, R.C., FRANKLE, S.C., Prompt Gamma Rays from Radiative Capture of Thermal Neutrons by Elements from Hydrogen through Zinc, *At. Data Nucl. Data Tables* **80** (2002) 1.
- [8.3] REEDY, R.C., FRANKLE, S.C., Evaluated Database for Prompt Gamma Rays from Radiative Capture of Thermal Neutrons by Elements from Hydrogen to Zinc, IAEA(NDS)-209, January 2003.
- [8.4] MUGHABGHAB, S.F., Thermal Neutron Capture Cross Sections, Resonance Integrals, and g-factors, INDC(NDS)-440 (2003).
- [8.5] MUGHABGHAB, S.F., DIVADEENAM, M., HOLDEN, N., Neutron Cross Sections, Vol. 1, Part A, Z = 1 - 60, Academic Press, New York, 1981.
- [8.6] MUGHABGHAB, S.F., Neutron Cross Sections, Vol. 1, Part B, Z = 61 - 100, Academic Press, New York, 1984.

BUDAPEST REACTOR GAMMA-RAY CROSS-SECTION DATA

Zs. Révay, G.L. Molnár

The following table contains isotopic gamma-ray energy and thermal neutron radiative cross sections measured with the thermal neutron beam at the Budapest Reactor. Only transitions with $\sigma_{\gamma}^z(E_{\gamma})$ larger than 5% of the highest cross section for gamma rays ≥ 100 keV are listed for each element. The complete set of data is available on the CD-ROM accompanying this document. These data are discussed in greater detail in Chapter 6.

E_{γ} -keV	$\sigma_{\gamma}^z(E_{\gamma})$ -barns	E_{γ} -keV	$\sigma_{\gamma}^z(E_{\gamma})$ -barns	E_{γ} -keV	$\sigma_{\gamma}^z(E_{\gamma})$ -barns
Hydrogen		870.68(3)	1.75(11)E-4	472.222(13)	0.478(4)
2223.2590(10)	0.3326(7)	1087.71(3)	1.51(9)E-4	869.221(17)	0.1080(13)
Deuterium		2184.38(4)	1.75(11)E-4	874.399(18)	0.0759(11)
6250.2(1)	0.000492(25)	3272.11(7)	3.53(25)E-5	1636.23(4)	0.0250(7)
Lithium		Fluorine		2025.15(5)	0.0338(9)
980.48(4)	0.00410(14)	166.61(3)	0.000405(20)	2208.27(5)	0.0254(7)
1051.81(5)	0.00410(12)	556.29(3)	2.01(10)E-4	2517.59(5)	0.0695(11)
2032.300(20)	0.0387(12)	583.493(22)	0.00352(15)	2752.27(7)	0.0654(12)
7246.7(3)	0.0024(3)	655.942(22)	0.00196(9)	3587.31(7)	0.0596(12)
Beryllium		661.71(4)	2.25(14)E-4	3981.15(8)	0.0678(12)
853.631(11)	0.00165(15)	665.137(23)	0.00150(7)	6395.05(13)	0.1010(20)
2590.014(25)	0.00188(17)	822.64(3)	2.21(12)E-4	Magnesium	
3367.48(4)	0.0029(3)	983.467(25)	0.00117(5)	389.64(3)	0.0058(3)
3443.42(4)	0.00099(9)	1045.96(4)	1.84(12)E-4	584.936(24)	0.0316(15)
6809.58(10)	0.0062(6)	1056.70(3)	0.00096(4)	974.61(3)	0.0067(3)
Boron		1148.02(5)	0.000252(16)	1003.05(3)	0.00165(8)
480(3)	713.0(23)	1309.12(3)	0.00076(4)	1129.42(3)	0.0090(4)
Carbon		1387.82(3)	0.00079(4)	1808.62(6)	0.0181(8)
1261.71(6)	0.00123(3)	1542.47(5)	0.000265(17)	2438.42(9)	0.00459(22)
3684.02(7)	0.00117(4)	1843.68(4)	0.00059(3)	2828.12(10)	0.0239(11)
4945.30(7)	0.00270(8)	2143.20(7)	1.94(14)E-4	2881.52(11)	0.00279(15)
Nitrogen		2427.83(11)	1.87(18)E-4	3053.85(12)	0.0083(4)
1678.24(3)	0.00625(9)	2431.04(7)	0.00041(3)	3301.29(13)	0.0063(3)
1681.17(4)	0.00130(4)	2529.21(6)	0.00065(4)	3413.04(14)	0.00400(20)
1884.85(3)	0.01450(18)	3014.61(7)	0.000407(25)	3561.14(14)	0.00252(13)
1999.69(3)	0.00321(5)	3051.56(10)	0.000301(23)	3831.25(16)	0.00408(20)
2520.45(4)	0.00425(8)	3112.88(9)	2.17(16)E-4	3916.65(16)	0.0314(15)
2830.80(5)	0.00133(4)	3488.15(8)	0.00077(5)	5451.79(23)	0.00205(12)
3531.98(5)	0.00686(12)	3586.23(14)	0.00026(3)	8153.4(4)	0.00271(19)
3677.80(5)	0.01140(15)	3589.42(15)	2.0(3)E-4	Aluminum	
4508.69(6)	0.01290(21)	3964.85(10)	0.00039(3)	831.41(5)	0.00269(7)
5268.98(7)	0.0237(4)	4556.90(11)	0.00044(3)	982.94(4)	0.00902(14)
5297.66(15)	0.0167(3)	5033.53(11)	0.00070(4)	1013.57(4)	0.00555(10)
5533.25(8)	0.01570(25)	5279.42(13)	0.00042(4)	1408.27(4)	0.00640(13)
5561.95(8)	0.00863(15)	5291.46(15)	2.3(3)E-4	1526.12(4)	0.00339(9)
6322.30(9)	0.0149(3)	5543.70(13)	0.00039(4)	1589.59(4)	0.00247(7)
7298.90(10)	0.00772(16)	5616.88(16)	1.76(15)E-4	1622.90(3)	0.00989(15)
8310.17(13)	0.00336(9)	6017.04(11)	0.00094(6)	1927.44(4)	0.00262(7)
9149.24(17)	0.00133(6)	6600.39(11)	0.00099(5)	2108.19(4)	0.00549(11)
10829.10(21)	0.0107(4)	Sodium		2138.82(4)	0.00424(9)
Oxygen		90.979(16)	0.235(3)	2271.77(4)	0.00396(10)

$E\gamma$ -keV	$\sigma_{\gamma}^z(E\gamma)$ -barns	$E\gamma$ -keV	$\sigma_{\gamma}^z(E\gamma)$ -barns	$E\gamma$ -keV	$\sigma_{\gamma}^z(E\gamma)$ -barns
2282.71(4)	0.00890(17)	5265.46(11)	0.0060(3)	4135.58(9)	0.0563(17)
2577.53(5)	0.00412(10)	5705.41(13)	0.00447(25)	4360.22(9)	0.0776(21)
2590.10(5)	0.00807(16)	6785.30(14)	0.0276(14)	5379.96(12)	0.146(4)
2625.67(5)	0.00264(6)	7422.08(17)	0.0086(5)	5695.45(13)	0.114(3)
2821.31(6)	0.00752(15)	Sulfur		5751.76(13)	0.108(3)
3033.75(6)	0.0179(3)	841.013(14)	0.348(6)	Calcium	
3464.87(8)	0.0146(3)	2379.50(4)	0.208(3)	519.56(8)	0.0503(13)
3590.93(9)	0.01000(21)	2753.09(5)	0.0277(5)	1942.68(3)	0.352(7)
3848.95(10)	0.00699(17)	2930.59(5)	0.0832(13)	2001.31(3)	0.0659(15)
3875.35(10)	0.00618(14)	3220.36(6)	0.1240(20)	2009.84(3)	0.0409(10)
4133.20(10)	0.0149(3)	3369.48(6)	0.0272(5)	3609.84(9)	0.0284(9)
4259.35(11)	0.0153(3)	4430.28(9)	0.0263(6)	4418.50(12)	0.0708(18)
4659.81(13)	0.00605(16)	4869.19(9)	0.0652(13)	5899.99(20)	0.0258(12)
4690.48(13)	0.01090(24)	5420.24(10)	0.309(7)	6419.69(21)	0.176(5)
4733.63(14)	0.0126(3)	Chlorine		Scandium	
4902.89(14)	0.00716(18)	517.077(8)	7.43(7)	52.049(21)	0.87(3)
5133.99(15)	0.00722(23)	786.18(15)	3.6(17)	142.627(16)	4.88(7)
5410.79(16)	0.00481(19)	788.37(21)	4.9(23)	147.114(16)	6.08(9)
5585.38(19)	0.00279(12)	1131.180(15)	0.634(10)	216.475(17)	2.49(4)
6101.54(19)	0.00570(21)	1162.56(5)	0.71(3)	227.860(16)	7.13(11)
6315.91(20)	0.00500(20)	1164.831(12)	8.92(7)	228.806(16)	3.31(5)
7693.1(3)	0.0081(3)	1601.055(14)	1.230(15)	295.343(19)	3.97(11)
7723.78(25)	0.0493(15)	1951.150(15)	6.49(5)	486.054(21)	0.593(14)
Silicon		1959.359(16)	4.18(4)	539.466(25)	0.738(19)
1273.38(3)	0.0289(6)	2676.11(3)	0.524(10)	547.14(3)	0.373(12)
2092.91(3)	0.0330(6)	2863.76(3)	1.830(25)	554.555(23)	1.82(4)
3538.98(5)	0.1180(20)	3061.76(3)	1.110(19)	584.80(3)	1.77(3)
3660.73(6)	0.00705(21)	4979.75(5)	1.260(24)	627.477(22)	2.23(5)
4933.83(7)	0.1120(23)	5517.13(8)	0.578(17)	721.78(3)	0.487(15)
5106.60(10)	0.0065(3)	5715.16(7)	1.86(4)	773.834(22)	0.572(13)
6379.75(11)	0.0210(6)	6110.71(7)	7.37(11)	807.74(3)	0.523(13)
7199.02(13)	0.0127(4)	6619.58(8)	2.75(4)	860.66(3)	0.396(13)
Phosphorus		6627.87(8)	1.56(3)	1123.41(5)	0.380(14)
77.992(23)	0.059(3)	6977.75(10)	0.794(21)	1166.60(4)	0.386(14)
512.650(18)	0.079(4)	7413.92(10)	3.57(6)	1285.31(9)	0.373(19)
636.570(17)	0.0310(14)	7790.28(11)	2.89(6)	1335.04(3)	0.640(22)
1071.154(20)	0.0248(12)	8578.58(15)	0.93(3)	1618.16(7)	0.362(19)
1322.639(25)	0.00526(25)	Potassium		1693.35(5)	0.465(19)
1676.81(3)	0.00402(20)	770.325(23)	0.903(12)	1857.62(6)	0.393(17)
1941.01(4)	0.00411(20)	1158.880(24)	0.1600(25)	4974.54(10)	0.498(24)
2114.32(4)	0.0114(5)	1247.20(3)	0.0784(13)	5267.04(10)	0.38(3)
2151.42(4)	0.0099(5)	1303.42(3)	0.0550(12)	5896.90(17)	0.42(3)
2156.74(4)	0.0127(6)	1613.76(3)	0.1190(20)	6170.24(16)	0.47(5)
2585.82(5)	0.0088(4)	1618.98(3)	0.1300(21)	6317.64(25)	0.58(4)
2885.89(5)	0.0064(3)	2007.71(4)	0.0513(12)	6349.4(3)	0.53(4)
3057.94(6)	0.0109(5)	2017.49(4)	0.0540(12)	6556.82(14)	0.384(24)
3273.87(7)	0.0084(4)	2039.94(4)	0.0519(13)	6839.73(11)	0.95(4)
3522.49(7)	0.0224(11)	2047.33(4)	0.0537(13)	7117.01(18)	0.39(3)
3899.65(8)	0.0301(14)	2073.67(4)	0.1370(24)	7635.42(20)	0.40(3)
4199.70(9)	0.0057(3)	2290.64(5)	0.0582(13)	8132.37(18)	0.48(3)
4364.24(9)	0.0074(4)	2545.92(6)	0.0536(12)	8175.07(10)	1.80(6)
4660.97(10)	0.0057(3)	3055.30(7)	0.0464(12)	8315.75(16)	0.41(3)
4671.21(9)	0.0199(10)	3545.64(9)	0.0746(18)	8532.07(12)	0.89(4)

Eγ-keV	$\sigma_{\gamma}^z(\text{E}\gamma)\text{-barns}$	Eγ-keV	$\sigma_{\gamma}^z(\text{E}\gamma)\text{-barns}$	Eγ-keV	$\sigma_{\gamma}^z(\text{E}\gamma)\text{-barns}$
Titanium		104.611(23)	1.74(3)	4405.90(7)	0.0453(13)
341.69(3)	1.840(21)	188.521(22)	0.330(6)	4809.70(8)	0.0416(13)
1381.74(3)	5.18(12)	212.039(21)	2.13(3)	5920.25(8)	0.225(5)
1498.65(3)	0.297(5)	215.150(22)	0.168(3)	6018.29(8)	0.227(5)
1585.95(3)	0.624(8)	230.096(24)	0.193(4)	7278.83(10)	0.137(4)
1762.02(3)	0.311(4)	271.198(22)	0.94(6)	7631.05(9)	0.653(13)
4881.24(6)	0.308(7)	314.398(20)	1.460(20)	7645.48(9)	0.549(11)
6418.35(8)	1.96(6)	335.502(24)	0.147(3)	9297.90(21)	0.0747(25)
6555.87(9)	0.334(8)	375.192(22)	0.124(3)		
6760.01(9)	2.97(9)	454.378(21)	0.388(7)	Cobalt	
Vanadium		459.754(23)	0.210(5)	58.90(22)	0.392(4)
125.23(3)	1.61(4)	2043.99(5)	0.243(5)	158.519(12)	1.200(15)
148.09(3)	0.253(6)	2062.81(4)	0.179(5)	229.811(12)	7.18(8)
295.196(25)	0.164(4)	2175.91(5)	0.111(4)	254.371(12)	1.290(16)
419.624(24)	0.249(6)	2294.42(7)	0.112(6)	277.199(11)	6.77(8)
436.765(23)	0.397(9)	2330.55(7)	0.191(8)	391.221(12)	1.080(14)
645.789(22)	0.769(17)	3267.17(7)	0.188(6)	435.671(12)	0.789(10)
793.614(23)	0.199(5)	3408.61(5)	0.303(10)	447.717(11)	3.41(4)
823.26(3)	0.320(8)	4566.56(10)	0.197(9)	461.064(15)	0.519(9)
846.046(24)	0.252(7)	4689.14(11)	0.120(9)	484.284(11)	0.804(11)
1358.52(3)	0.151(5)	4724.84(8)	0.281(10)	497.264(13)	2.16(4)
1558.89(3)	0.323(8)	4949.21(8)	0.274(10)	555.941(10)	5.76(6)
1778.02(13)	0.169(13)	5014.37(7)	0.737(20)	710.493(16)	0.660(12)
2145.88(7)	0.140(4)	5034.60(15)	0.108(8)	717.302(14)	0.845(14)
4117.10(21)	0.094(4)	5067.87(9)	0.265(12)	726.616(21)	0.448(10)
5142.40(14)	0.200(6)	5180.89(8)	0.412(13)	785.614(17)	2.41(7)
5210.18(16)	0.244(20)	5253.98(12)	0.132(13)	901.148(18)	0.418(9)
5515.90(17)	0.39(4)	5527.08(8)	0.788(22)	930.47(5)	0.408(22)
5752.27(14)	0.366(24)	5761.23(11)	0.200(12)	1215.965(20)	0.520(9)
5892.46(15)	0.126(7)	5920.39(8)	1.06(3)	1507.28(3)	0.463(9)
6465.09(18)	0.43(4)	6104.29(12)	0.213(10)	1515.695(25)	1.740(25)
6517.62(15)	0.78(4)	6783.74(12)	0.378(17)	1830.77(3)	1.700(23)
6874.48(20)	0.49(6)	6929.22(13)	0.248(12)	1852.70(3)	0.456(10)
7163.17(18)	0.59(4)	7057.89(9)	1.22(3)	2032.74(4)	0.393(11)
7294.13(23)	0.089(5)	7159.63(10)	0.643(24)	3748.76(7)	0.415(13)
7310.98(21)	0.227(9)	7243.52(9)	1.36(3)	4906.06(17)	0.43(3)
Chromium		7270.14(12)	0.362(15)	5181.14(12)	0.912(23)
564.14(3)	0.1130(20)	Iron		5269.92(12)	0.404(11)
749.10(3)	0.569(9)	122.078(22)	0.096(3)	5602.39(10)	0.434(16)
834.80(3)	1.38(3)	352.332(16)	0.273(3)	5614.04(10)	0.399(15)
1784.41(4)	0.177(3)	366.737(16)	0.0497(7)	5638.55(10)	0.379(15)
1898.90(4)	0.0851(21)	691.914(16)	0.1370(18)	5660.68(16)	1.89(6)
2238.78(4)	0.185(3)	898.14(3)	0.0540(10)	5742.16(9)	0.766(23)
2320.80(4)	0.136(3)	1018.860(21)	0.0507(11)	5925.39(10)	0.643(18)
5617.37(10)	0.132(5)	1260.353(21)	0.0684(11)	5975.60(22)	2.9(4)
6134.19(12)	0.078(4)	1612.77(3)	0.1530(22)	6486.17(13)	2.32(5)
7361.09(14)	0.091(4)	1725.255(24)	0.181(3)	6705.52(10)	3.02(6)
7373.85(15)	0.080(4)	2721.18(5)	0.0384(13)	6876.76(11)	3.02(6)
7937.86(12)	0.424(11)	3267.30(6)	0.0367(13)	6984.9(4)	1.05(13)
8482.84(14)	0.168(7)	3413.14(6)	0.0449(14)	7055.43(12)	0.666(19)
8510.68(14)	0.231(8)	3436.57(13)	0.045(4)	7203.02(13)	0.369(16)
Manganese		3854.17(7)	0.0333(12)	7214.09(12)	1.38(3)
83.884(23)	3.11(5)	4217.93(6)	0.099(3)	7491.29(12)	1.16(3)

$E\gamma$ -keV	$\sigma_{\gamma}^z(E\gamma)$ -barns	$E\gamma$ -keV	$\sigma_{\gamma}^z(E\gamma)$ -barns	$E\gamma$ -keV	$\sigma_{\gamma}^z(E\gamma)$ -barns
Nickel		1007.806(25)	0.0557(15)	6111.19(16)	0.056(4)
282.940(18)	0.211(3)	1077.336(17)	0.356(5)	6128.73(23)	0.024(3)
339.370(18)	0.1660(21)	1126.10(3)	0.0224(7)	6360.02(13)	0.138(5)
464.972(18)	0.843(10)	1261.17(3)	0.0433(11)	6513.06(18)	0.0325(20)
877.984(19)	0.236(3)	1340.15(3)	0.0431(13)	Germanium	
5817.17(6)	0.1090(24)	1673.46(5)	0.0255(11)	175.05(3)	0.164(4)
6583.78(7)	0.0837(21)	1883.11(4)	0.0726(22)	253.22(3)	0.0609(16)
6837.44(6)	0.458(8)	2210.12(9)	0.0270(13)	325.74(3)	0.0649(18)
7536.56(8)	0.191(4)	4137.28(12)	0.0196(23)	492.989(22)	0.133(3)
7819.55(8)	0.337(6)	5473.74(12)	0.040(4)	499.966(22)	0.158(4)
8120.60(9)	0.133(3)	6867.51(17)	0.0243(17)	595.879(20)	1.100(24)
8533.45(8)	0.721(13)	6910.92(16)	0.0192(14)	608.375(21)	0.250(6)
8998.31(9)	1.49(3)	6958.45(12)	0.042(3)	701.490(24)	0.0642(19)
Copper		7069.17(17)	0.0217(14)	708.14(3)	0.0821(23)
88.86(3)	0.0970(17)	7863.54(11)	0.141(5)	867.940(23)	0.553(12)
159.02(3)	0.649(8)	Gallium		961.04(4)	0.129(4)
185.66(3)	0.244(3)	88.97(3)	0.0306(9)	999.78(3)	0.0581(19)
202.69(3)	0.1940(25)	103.25(3)	0.0525(11)	1101.22(3)	0.134(3)
277.993(25)	0.893(12)	112.46(3)	0.155(3)	1105.56(3)	0.0708(20)
343.651(25)	0.215(3)	145.24(3)	0.465(7)	1204.14(4)	0.141(4)
384.27(3)	0.0701(11)	153.90(3)	0.0319(8)	1471.75(5)	0.083(3)
385.37(3)	0.1310(18)	181.60(7)	0.037(4)	Arsenic	
464.857(25)	0.1350(21)	184.13(3)	0.1040(21)	74.88(8)	0.12(3)
467.74(3)	0.0673(13)	187.84(3)	0.1080(21)	86.83(3)	0.579(11)
503.45(3)	0.0596(10)	192.09(3)	0.194(3)	116.91(7)	0.107(18)
579.48(3)	0.0899(14)	194.67(3)	0.1060(21)	117.58(10)	0.071(18)
608.52(3)	0.266(5)	198.00(3)	0.1330(24)	120.28(3)	0.402(8)
648.53(3)	0.101(3)	211.08(3)	0.0343(8)	122.26(3)	0.227(5)
662.67(5)	0.067(5)	212.58(3)	0.0582(12)	127.55(3)	0.096(3)
5417.60(9)	0.0564(23)	229.06(3)	0.0377(10)	135.48(3)	0.156(4)
6009.96(18)	0.0453(25)	248.95(4)	0.140(10)	141.24(4)	0.0625(21)
6600.08(13)	0.078(5)	264.02(4)	0.0238(9)	144.60(3)	0.1000(22)
6674.12(13)	0.0534(24)	266.09(4)	0.0361(11)	157.79(8)	0.117(24)
6679.64(11)	0.067(3)	315.95(4)	0.0275(9)	165.09(3)	0.996(16)
6987.99(9)	0.092(3)	318.87(3)	0.0592(14)	178.16(3)	0.0979(23)
7175.93(12)	0.070(4)	374.37(4)	0.0303(10)	187.94(4)	0.090(3)
7252.10(11)	0.114(5)	390.64(3)	0.0477(12)	198.70(3)	0.089(3)
7306.25(9)	0.245(6)	393.26(3)	0.1340(23)	211.18(3)	0.113(3)
7571.23(14)	0.047(3)	411.11(3)	0.0384(11)	221.60(4)	0.0534(25)
7636.75(9)	0.428(9)	508.19(3)	0.349(6)	225.76(3)	0.0803(24)
7915.00(9)	0.869(16)	651.09(3)	0.1030(22)	235.84(3)	0.181(4)
Zinc		690.943(24)	0.305(4)	263.88(5)	0.18(4)
53.97(3)	0.0225(20)	1140.37(4)	0.0422(16)	281.56(6)	0.085(20)
61.2530(20)	0.055(5)	1203.40(6)	0.0286(14)	297.55(4)	0.055(3)
93.386(22)	0.0343(8)	1311.89(6)	0.0259(12)	300.44(5)	0.051(3)
115.256(23)	0.167(3)	4839.99(13)	0.040(3)	352.41(4)	0.071(3)
153.124(22)	0.0322(6)	5194.5(3)	0.033(3)	357.36(4)	0.074(3)
184.665(20)	0.0321(4)	5233.47(14)	0.0341(20)	363.94(4)	0.059(3)
300.317(25)	0.0202(6)	5334.13(18)	0.0271(18)	402.64(4)	0.061(3)
751.68(3)	0.0307(10)	5340.59(14)	0.0409(22)	426.62(3)	0.100(3)
834.78(3)	0.0372(12)	5488.31(17)	0.0296(19)	471.05(3)	0.203(5)
855.66(8)	0.066(6)	5601.79(15)	0.063(4)	473.21(3)	0.176(5)
909.65(4)	0.0186(8)	6008.11(14)	0.070(5)	550.48(4)	0.071(3)

$E\gamma$ -keV	$\sigma_{\gamma}^z(E\gamma)$ -barns	$E\gamma$ -keV	$\sigma_{\gamma}^z(E\gamma)$ -barns	$E\gamma$ -keV	$\sigma_{\gamma}^z(E\gamma)$ -barns
6295.2(4)	0.064(6)	244.31(4)	0.45(3)	1105.51(4)	0.0151(3)
6810.11(21)	0.160(8)	245.23(3)	0.80(3)	1304.45(4)	0.0204(5)
6926.22(22)	0.061(4)	271.39(3)	0.462(7)	1389.31(5)	0.00809(21)
7020.0(3)	0.104(7)	274.54(3)	0.158(3)	1666.78(6)	0.00774(23)
Selenium		287.76(3)	0.253(4)	6065.00(25)	0.0047(3)
87.87(3)	0.210(4)	294.32(3)	0.1160(22)	6471.30(25)	0.0049(3)
139.28(3)	0.542(9)	299.95(16)	0.08(8)	6520.7(3)	0.0064(4)
161.99(3)	0.855(22)	315.05(3)	0.460(9)	6832.2(3)	0.0064(4)
200.50(4)	0.240(10)	343.42(4)	0.118(4)	7346.0(3)	0.0059(3)
239.06(3)	2.06(3)	345.09(4)	0.154(4)	7624.1(3)	0.0114(5)
249.85(3)	0.539(9)	366.58(4)	0.233(6)	Strontium	
281.68(3)	0.125(4)	389.10(4)	0.0486(13)	388.526(22)	0.0517(9)
286.62(3)	0.280(6)	432.20(3)	0.0783(14)	585.610(20)	0.0704(14)
297.26(3)	0.338(7)	452.69(6)	0.0679(24)	850.671(17)	0.275(4)
439.52(3)	0.320(8)	459.76(6)	0.0455(19)	898.063(16)	0.703(10)
467.77(4)	0.128(4)	468.91(4)	0.29(3)	1218.548(24)	0.0597(13)
484.45(4)	0.125(4)	512.22(5)	0.21(3)	1717.81(3)	0.0672(15)
518.21(4)	0.274(7)	542.39(4)	0.114(5)	1836.05(3)	1.030(18)
520.68(3)	1.270(19)	549.45(3)	0.0593(14)	3009.34(7)	0.0579(16)
578.85(3)	0.244(5)	565.98(4)	0.0551(12)	6266.82(17)	0.075(3)
613.72(3)	2.14(5)	608.70(4)	0.0438(13)	6660.38(18)	0.064(3)
694.88(3)	0.444(10)	660.38(6)	0.082(3)	7527.58(20)	0.067(3)
755.34(3)	0.186(4)	684.84(5)	0.050(3)	Yttrium	
817.86(4)	0.175(5)	689.87(4)	0.083(4)	202.58(4)	0.291(4)
885.40(4)	0.262(7)	701.97(4)	0.0648(14)	574.13(4)	0.172(4)
888.84(4)	0.180(5)	715.93(4)	0.0420(23)	776.64(3)	0.659(9)
1005.01(4)	0.118(5)	765.75(5)	0.0537(16)	1211.56(4)	0.0447(12)
1240.06(5)	0.109(5)	830.72(4)	0.0413(12)	1371.09(6)	0.0400(12)
1296.92(4)	0.241(7)	860.41(7)	0.0450(19)	4107.52(6)	0.0518(17)
1308.60(4)	0.317(9)	914.25(4)	0.0508(14)	6080.12(7)	0.754(13)
1411.51(9)	0.117(6)	976.41(4)	0.0459(13)	Zirconium	
1713.48(6)	0.159(7)	1248.78(12)	0.0527(22)	160.94(10)	0.0111(7)
1995.83(6)	0.123(6)	7030.72(15)	0.0447(22)	266.78(7)	0.0091(5)
4526.6(3)	0.118(8)	7077.34(14)	0.0566(24)	448.13(7)	0.0067(3)
4565.5(3)	0.163(12)	7422.40(14)	0.0495(18)	560.91(6)	0.0285(5)
5025.57(12)	0.141(12)	7576.27(14)	0.108(3)	844.08(7)	0.0095(4)
5600.89(13)	0.287(14)	Rubidium		912.71(7)	0.0117(5)
5795.65(17)	0.112(15)	113.75(3)	0.00535(14)	934.47(6)	0.125(5)
6006.85(13)	0.269(16)	196.34(3)	0.00964(19)	1102.67(6)	0.0235(8)
6232.01(17)	0.177(17)	421.494(23)	0.0259(5)	1132.10(7)	0.0100(7)
6413.36(15)	0.184(15)	487.89(3)	0.0494(12)	1206.89(8)	0.0417(25)
6600.67(12)	0.613(20)	514.55(3)	0.00653(20)	1405.02(6)	0.0301(10)
7179.51(15)	0.237(19)	536.50(3)	0.0167(5)	1847.78(15)	0.0084(8)
7418.52(14)	0.342(13)	538.66(3)	0.0169(5)	5262.7(4)	0.0064(8)
9188.42(21)	0.128(8)	555.61(3)	0.0407(10)	6294.86(18)	0.0279(20)
9883.30(22)	0.180(10)	556.81(3)	0.0913(24)	Niobium	
Bromine		638.82(6)	0.0101(13)	78.63(3)	0.0169(3)
59.57(3)	0.202(5)	691.57(3)	0.00725(18)	99.41(3)	0.196(9)
195.64(3)	0.434(14)	872.93(3)	0.0321(5)	113.39(3)	0.117(3)
211.62(4)	0.0454(21)	881.53(4)	0.00480(17)	161.24(3)	0.0190(5)
219.37(3)	0.399(14)	913.12(4)	0.00497(15)	253.135(23)	0.1320(19)
223.64(3)	0.153(5)	1026.35(3)	0.0218(4)	255.957(23)	0.176(3)
234.32(3)	0.205(10)	1032.32(3)	0.0227(4)	293.223(25)	0.0651(16)

$E\gamma$ -keV	$\sigma_{\gamma}^z(E\gamma)$ -barns	$E\gamma$ -keV	$\sigma_{\gamma}^z(E\gamma)$ -barns	$E\gamma$ -keV	$\sigma_{\gamma}^z(E\gamma)$ -barns
309.926(25)	0.0690(17)	686.890(13)	0.52(5)	192.90(3)	2.20(6)
329.19(3)	0.0108(4)	822.610(19)	0.137(12)	195.34(4)	0.50(3)
337.48(4)	0.054(6)	1046.4980(20)	0.103(9)	198.52(3)	7.75(13)
458.47(3)	0.0240(5)	1103.03(3)	0.100(9)	201.31(6)	0.45(3)
499.48(3)	0.0648(18)	1341.52(3)	0.137(12)	206.46(3)	3.58(7)
518.16(3)	0.0579(13)	1362.02(7)	0.111(13)	215.15(4)	1.55(3)
527.64(5)	0.0127(7)	1627.24(3)	0.129(12)	235.62(3)	4.62(7)
562.29(5)	0.0293(11)	1959.33(3)	0.210(19)	236.85(4)	1.95(3)
689.78(4)	0.0164(6)	6627.84(14)	0.093(9)	259.17(3)	1.560(25)
751.69(5)	0.0143(6)	7790.53(16)	0.132(13)	267.08(3)	2.73(6)
755.30(5)	0.0123(6)	Rhodium		270.00(4)	0.565(25)
775.75(4)	0.0158(6)	51.34(4)	14.6(16)	286.91(4)	0.400(25)
835.75(4)	0.0376(8)	85.19(3)	3.2(3)	294.39(3)	2.05(12)
878.99(8)	0.0191(17)	96.99(3)	20.1(4)	299.95(3)	1.15(5)
883.74(5)	0.0192(7)	100.68(3)	4.96(10)	328.99(3)	0.795(12)
894.27(5)	0.0185(7)	127.21(3)	5.27(21)	338.742(25)	0.595(10)
896.96(6)	0.0144(7)	134.54(3)	6.8(4)	349.95(3)	0.70(4)
911.61(5)	0.0176(7)	169.26(7)	2.88(19)	357.77(5)	0.561(22)
957.27(4)	0.0248(7)	177.64(4)	1.85(12)	360.39(3)	1.55(3)
1121.9(3)	0.0106(13)	180.73(3)	22.6(12)	378.12(5)	0.744(20)
1129.01(10)	0.0175(15)	185.93(3)	1.50(5)	380.90(3)	1.59(3)
1192.10(7)	0.0137(7)	202.69(5)	1.6(3)	408.61(3)	0.459(9)
1206.48(8)	0.0284(10)	212.92(3)	1.27(3)	465.37(6)	0.46(3)
1223.01(10)	0.0121(7)	215.35(3)	6.74(12)	495.714(25)	1.080(18)
1228.40(11)	0.0114(7)	217.75(3)	7.38(13)	524.473(25)	0.804(11)
1239.54(10)	0.0096(7)	266.60(3)	2.66(14)	536.125(24)	1.090(16)
1291.47(8)	0.0097(7)	269.17(3)	1.42(11)	549.560(23)	1.540(24)
1392.82(9)	0.0105(8)	323.79(10)	1.54(19)	586.81(3)	0.459(8)
1459.99(10)	0.0095(6)	333.44(3)	3.27(8)	593.88(3)	0.484(11)
4739.39(23)	0.0153(9)	374.79(3)	1.300(25)	620.08(4)	0.40(5)
5070.5(3)	0.0102(8)	420.61(3)	2.06(4)	626.41(4)	0.39(6)
5103.62(24)	0.0232(12)	440.52(3)	2.23(10)	632.95(3)	0.42(12)
5193.8(3)	0.0114(8)	470.41(3)	2.61(7)	657.741(22)	2.36(3)
5496.46(25)	0.0205(14)	482.24(3)	1.78(6)	724.75(4)	0.393(14)
5895.3(3)	0.0183(8)	786.94(4)	1.16(3)	750.77(3)	0.529(11)
6831.7(3)	0.0175(8)	5917.04(14)	1.31(4)	1013.11(3)	0.698(13)
7186.6(3)	0.0089(6)	Palladium		5701.49(20)	0.716(18)
Molybdenum		113.47(3)	0.335(5)	5795.02(24)	0.513(14)
608.753(18)	0.121(4)	245.128(24)	0.250(4)	6058.03(22)	0.663(19)
719.523(17)	0.310(10)	325.310(23)	0.208(3)	Cadmium	
736.814(16)	0.119(4)	511.847(13)	4.00(4)	558.32(3)	1860(30)
778.221(10)	2.02(6)	616.219(15)	0.628(9)	576.04(3)	107.0(17)
787.398(15)	0.168(5)	717.349(14)	0.777(9)	651.19(3)	358(5)
847.605(12)	0.324(9)	1045.77(3)	0.321(7)	725.19(3)	107.0(13)
1091.298(25)	0.201(6)	1050.30(3)	0.360(8)	805.85(3)	134.0(18)
1200.13(4)	0.124(4)	1127.99(3)	0.323(6)	1209.65(4)	122.0(19)
1497.65(5)	0.122(4)	1572.57(9)	0.22(3)	1364.30(4)	123.0(21)
6918.7(4)	0.106(6)	Silver		1399.54(4)	97.7(15)
Ruthenium		78.91(4)	3.90(12)	Indium	
475.0950(10)	0.98(9)	105.61(5)	0.76(4)	60.97(4)	8.6(5)
539.522(11)	1.53(13)	113.51(6)	0.52(3)	85.66(4)	11.1(6)
627.974(16)	0.176(16)	117.45(3)	3.84(7)	96.11(4)	13.8(7)
631.24(3)	0.30(3)	191.39(3)	1.81(5)	126.49(4)	2.05(11)

$E\gamma$ -keV	$\sigma_{\gamma}^z(E\gamma)$ -barns	$E\gamma$ -keV	$\sigma_{\gamma}^z(E\gamma)$ -barns	$E\gamma$ -keV	$\sigma_{\gamma}^z(E\gamma)$ -barns
141.17(7)	1.61(24)	87.83(4)	0.212(6)	775.58(9)	0.020(3)
155.40(5)	1.38(9)	88.96(9)	0.0220(25)	824.31(9)	0.040(3)
162.50(4)	15.8(8)	101.69(5)	0.0215(11)	921.04(4)	0.076(4)
171.16(4)	1.92(10)	103.79(5)	0.0578(18)	5563.4(3)	0.0200(24)
173.87(4)	2.30(14)	105.95(4)	0.161(4)	5868.89(22)	0.035(3)
186.32(4)	14.9(8)	115.04(4)	0.271(9)	5885.08(20)	0.055(4)
202.58(5)	1.50(9)	121.64(4)	0.360(8)	6009.1(3)	0.020(3)
235.21(4)	2.75(15)	124.17(5)	0.0310(14)	6048.81(25)	0.0184(25)
273.05(4)	18.3(9)	133.95(4)	0.0608(19)	6082.94(22)	0.0182(23)
285.00(4)	2.54(14)	138.12(5)	0.0286(12)	6363.5(3)	0.024(3)
291.00(4)	1.42(8)	141.54(5)	0.0577(18)	6379.82(22)	0.043(4)
295.58(4)	1.55(9)	143.35(5)	0.0331(14)	6467.8(4)	0.022(3)
298.72(4)	4.78(25)	148.39(4)	0.257(6)	6523.87(18)	0.075(3)
321.24(5)	1.28(8)	155.27(5)	0.091(3)	6728.38(23)	0.045(4)
335.47(4)	4.59(24)	166.56(5)	0.0699(23)	Tellurium	
337.84(5)	1.39(8)	167.73(6)	0.0512(20)	602.723(12)	2.37(24)
375.89(4)	1.47(9)	173.91(6)	0.0192(11)	645.823(14)	0.26(3)
385.06(4)	6.8(4)	194.20(4)	0.0534(18)	722.729(15)	0.52(5)
422.23(5)	0.97(6)	201.70(4)	0.091(3)	1488.89(3)	0.120(12)
433.80(4)	3.62(20)	204.68(5)	0.0355(15)	2746.94(5)	0.138(14)
471.92(4)	2.43(14)	232.23(4)	0.0356(12)	Iodine	
476.13(8)	1.05(7)	233.28(4)	0.0996(24)	124.27(4)	0.183(8)
492.52(5)	1.87(11)	246.42(4)	0.0589(16)	133.59(4)	1.42(6)
518.06(5)	1.74(11)	252.89(4)	0.0474(14)	142.12(4)	0.156(7)
521.62(7)	1.11(8)	255.54(7)	0.027(3)	147.10(4)	0.109(5)
548.70(5)	1.14(8)	256.37(8)	0.021(3)	152.99(4)	0.214(9)
556.67(4)	2.61(15)	265.51(6)	0.0299(16)	156.49(4)	0.118(5)
577.45(8)	1.10(10)	272.36(7)	0.0225(14)	160.71(4)	0.192(8)
602.36(4)	1.60(9)	274.22(8)	0.0388(18)	193.54(4)	0.127(5)
608.34(4)	1.97(11)	275.72(8)	0.0306(16)	224.15(4)	0.095(4)
634.03(9)	0.94(7)	282.73(4)	0.274(7)	248.73(4)	0.149(6)
693.24(5)	1.02(7)	286.60(5)	0.0375(17)	268.32(4)	0.082(4)
819.00(6)	1.43(10)	288.21(7)	0.0267(18)	301.89(4)	0.229(9)
847.50(6)	1.21(8)	313.97(5)	0.0318(18)	344.76(4)	0.102(5)
5892.38(15)	1.17(9)	322.19(5)	0.0390(20)	374.27(5)	0.091(5)
Tin		330.91(6)	0.058(3)	385.46(4)	0.087(4)
158.65(6)	0.0145(3)	332.15(5)	0.101(3)	420.85(5)	0.144(11)
463.31(6)	0.0128(3)	335.09(5)	0.0284(14)	Xenon	
703.87(7)	0.0078(3)	351.57(5)	0.0345(15)	483.77(9)	0.51(7)
733.91(6)	0.00925(21)	378.14(5)	0.0500(18)	536.29(9)	1.71(24)
813.26(7)	0.0071(3)	384.55(4)	0.0702(22)	586.23(10)	0.48(7)
818.71(6)	0.0127(4)	419.95(7)	0.071(8)	600.22(9)	0.54(8)
925.90(6)	0.0097(3)	485.34(6)	0.0218(15)	630.40(9)	1.38(19)
925.90(6)	0.0097(3)	491.21(5)	0.0354(16)	667.87(9)	6.9(10)
931.81(6)	0.0111(3)	513.88(8)	0.0359(21)	772.76(9)	1.9(3)
972.59(6)	0.0158(5)	542.35(8)	0.0270(20)	1028.88(8)	0.40(6)
1171.28(6)	0.0879(13)	546.01(6)	0.0315(20)	1318.00(8)	1.03(14)
1229.64(6)	0.0673(13)	555.18(12)	0.024(4)	6467.02(13)	1.33(19)
1293.53(6)	0.1340(21)	564.26(5)	0.0532(25)	Cesium	
1356.70(7)	0.0075(3)	598.66(5)	0.058(3)	59.85(7)	0.443(14)
2112.17(7)	0.0152(5)	603.49(12)	0.020(3)	113.60(7)	0.777(15)
2225.15(18)	0.0082(5)	631.81(4)	0.0581(16)	116.21(7)	2.83(4)
Antimony		746.85(9)	0.034(3)	118.04(8)	0.230(7)

$E\gamma$ -keV	$\sigma_{\gamma}^z(E\gamma)$ -barns	$E\gamma$ -keV	$\sigma_{\gamma}^z(E\gamma)$ -barns	$E\gamma$ -keV	$\sigma_{\gamma}^z(E\gamma)$ -barns
120.42(7)	0.414(10)	283.67(5)	0.0403(10)	2862.97(9)	0.066(4)
130.05(7)	1.410(21)	454.78(5)	0.0858(22)	2924.52(12)	0.040(3)
174.06(7)	0.420(11)	462.80(5)	0.0656(17)	2988.29(19)	0.045(4)
176.21(7)	2.47(4)	627.30(5)	0.293(6)	3016.74(9)	0.065(3)
186.67(7)	0.282(9)	732.32(5)	0.0239(7)	3035.23(11)	0.046(3)
198.11(7)	1.100(19)	818.47(5)	0.212(4)	3082.71(7)	0.135(5)
205.43(7)	1.560(25)	1009.61(5)	0.0167(5)	3188.94(15)	0.045(4)
211.15(7)	0.223(10)	1047.74(5)	0.0319(10)	3265.07(13)	0.049(5)
218.18(7)	0.309(9)	1435.65(6)	0.308(8)	3281.12(14)	0.048(5)
219.57(7)	0.344(9)	1444.71(6)	0.0799(21)	3424.65(11)	0.070(4)
234.15(7)	1.070(23)	1550.86(7)	0.0228(8)	3442.03(16)	0.040(3)
245.66(7)	0.740(15)	1898.47(8)	0.0285(11)	3476.53(16)	0.048(4)
256.44(7)	0.235(8)	2594.00(10)	0.0185(8)	3606.05(14)	0.054(4)
260.99(7)	0.401(11)	2639.09(11)	0.0170(8)	3609.85(16)	0.047(3)
268.82(7)	0.199(6)	3641.22(13)	0.0560(16)	3665.23(8)	0.132(6)
293.15(8)	0.185(9)	4095.77(15)	0.154(4)	3679.24(8)	0.137(6)
295.24(8)	0.231(10)	4723.12(18)	0.0262(11)	3727.27(11)	0.069(4)
307.07(7)	1.45(3)	5730.58(22)	0.0612(20)	3737.46(25)	0.042(4)
309.52(7)	0.237(9)	Lanthanum		3900.56(14)	0.053(4)
316.87(8)	0.149(10)	63.26(3)	0.176(6)	4389.17(9)	0.256(9)
356.06(7)	0.445(12)	155.65(3)	0.192(5)	4415.77(10)	0.240(9)
367.54(8)	0.173(8)	162.74(3)	0.490(13)	4502.26(11)	0.159(7)
377.05(7)	0.310(9)	209.29(4)	0.0434(19)	4558.45(14)	0.047(3)
386.73(7)	0.163(9)	218.30(3)	0.781(21)	4842.33(9)	0.656(17)
442.66(8)	0.316(12)	235.82(3)	0.111(3)	4888.37(12)	0.146(7)
450.27(8)	0.99(5)	237.747(24)	0.320(6)	5097.40(10)	0.680(18)
502.86(8)	0.256(13)	255.49(3)	0.0409(15)	5125.96(15)	0.110(7)
510.81(9)	1.54(3)	272.420(22)	0.502(8)	Cerium	
518.91(7)	0.349(18)	280.01(3)	0.0644(25)	475.09(6)	0.082(7)
523.47(17)	0.151(23)	283.69(4)	0.0411(25)	662.03(5)	0.233(18)
525.08(9)	0.39(3)	288.333(23)	0.729(12)	737.43(7)	0.026(3)
529.15(7)	0.519(23)	422.742(23)	0.371(7)	765.97(5)	0.0145(12)
539.16(7)	0.360(11)	426.51(5)	0.044(3)	1107.66(5)	0.040(3)
554.51(7)	0.206(9)	478.11(5)	0.0408(22)	1153.97(5)	0.0146(12)
557.57(11)	0.142(12)	495.66(3)	0.081(3)	4290.99(8)	0.053(4)
570.42(7)	0.221(12)	538.93(5)	0.0455(25)	4336.46(8)	0.0251(20)
645.53(9)	0.248(13)	549.02(3)	0.098(3)	4765.96(9)	0.109(9)
648.33(9)	0.233(13)	553.19(6)	0.061(4)	Praseodymium	
662.98(9)	0.155(9)	567.413(23)	0.335(7)	60.18(5)	0.134(14)
708.20(7)	0.220(11)	595.07(3)	0.103(3)	64.56(5)	0.137(6)
911.24(12)	0.177(14)	602.02(4)	0.0524(25)	68.67(5)	0.116(6)
966.47(10)	0.168(13)	623.60(4)	0.0518(23)	85.16(5)	0.207(11)
1077.67(9)	0.209(12)	640.62(6)	0.054(3)	126.92(4)	0.307(15)
5493.52(23)	0.230(19)	658.30(3)	0.103(3)	140.98(3)	0.479(10)
5505.46(20)	0.333(22)	667.67(4)	0.058(3)	176.95(3)	1.06(4)
5572.00(25)	0.249(20)	708.22(4)	0.134(4)	182.87(3)	0.377(14)
5637.41(23)	0.277(21)	710.07(8)	0.067(3)	460.24(5)	0.057(3)
5748.9(3)	0.146(15)	722.52(3)	0.212(5)	508.89(6)	0.104(10)
6052.3(3)	0.240(20)	782.86(8)	0.040(3)	528.23(3)	0.0579(19)
6175.64(22)	0.252(16)	868.11(6)	0.056(3)	546.47(3)	0.148(4)
6189.11(24)	0.191(14)	991.83(7)	0.049(3)	560.48(4)	0.150(7)
6697.91(24)	0.224(17)	1020.36(7)	0.054(3)	570.15(4)	0.112(5)
Barium		2757.44(9)	0.050(5)	573.88(5)	0.084(5)

$E\gamma$ -keV	$\sigma_{\gamma}^z(E\gamma)$ -barns	$E\gamma$ -keV	$\sigma_{\gamma}^z(E\gamma)$ -barns	$E\gamma$ -keV	$\sigma_{\gamma}^z(E\gamma)$ -barns
619.35(3)	0.152(4)	89.97(8)	1430(30)	253.52(10)	11(3)
633.19(4)	0.113(4)	91.20(10)	20(10)	256.20(9)	12.0(25)
645.651(25)	0.311(7)	95.25(11)	8(3)	260.66(9)	15.9(18)
729.24(3)	0.0712(23)	100.86(23)	24(5)	265.0(5)	3.8(5)
746.94(3)	0.146(4)	103.34(13)	48(5)	266.96(14)	8.0(11)
893.36(5)	0.053(3)	106.57(14)	42(6)	270.84(10)	6.5(11)
956.89(7)	0.091(7)	109.63(13)	22(9)	273.65(8)	17.3(12)
991.87(6)	0.138(10)	111.0(3)	22(6)	276.14(9)	10.9(11)
1006.30(5)	0.153(8)	113.1(3)	15(5)	279.91(14)	6.9(5)
1102.83(7)	0.056(3)	117.54(10)	14.7(22)	281.78(9)	20.4(8)
1150.98(4)	0.141(5)	119.71(13)	11.9(25)	283.53(24)	5.9(4)
3602.56(16)	0.054(3)	121.71(11)	17.7(25)	285.10(9)	23.2(18)
3650.12(16)	0.061(3)	124.01(16)	25(3)	287.29(10)	11.5(8)
3653.98(14)	0.060(4)	125.19(16)	25(3)	288.82(11)	9.3(6)
3790.15(11)	0.140(6)	129.06(12)	14.7(16)	293.68(14)	6.0(4)
4496.29(16)	0.098(6)	130.93(15)	15.0(16)	295.41(10)	13.4(5)
4691.91(14)	0.291(10)	132.71(10)	20.7(13)	297.40(12)	7.0(4)
4722.39(22)	0.083(4)	135.42(9)	27.8(14)	299.83(8)	24.0(6)
4800.96(16)	0.140(8)	137.89(20)	7(3)	304.22(9)	7.3(6)
5095.9(4)	0.208(8)	140.19(9)	21(4)	309.71(8)	11.5(9)
5137.43(22)	0.098(4)	143.54(8)	43(3)	313.97(24)	4.5(10)
5140.60(17)	0.269(11)	148.80(22)	13(4)	316.18(12)	10.8(9)
5665.98(18)	0.379(15)	150.59(19)	7(3)	318.95(11)	11.7(9)
5842.92(18)	0.147(6)	154.14(9)	22(3)	321.61(12)	9.8(8)
Neodymium		157.22(7)	7.5(22)	326.15(21)	12(4)
453.920(20)	3.00(9)	158.31(21)	9.3(16)	330.82(11)	9.0(8)
618.044(16)	13.4(3)	160.29(16)	9.3(17)	334.45(10)	11.1(10)
696.487(20)	33.2(17)	163.89(14)	13.1(24)	337.58(23)	4.1(9)
742.088(18)	3.07(8)	167.01(13)	18.9(19)	340.01(17)	5.5(9)
814.128(20)	5.05(13)	169.28(9)	54.8(22)	344.53(10)	7.1(14)
864.356(22)	5.08(13)	171.95(9)	40(3)	348.73(12)	7.5(13)
1413.16(3)	1.85(6)	176.6(3)	6(3)	353.10(18)	4.4(4)
6502.32(14)	3.18(11)	179.83(13)	20(3)	354.81(12)	8.7(14)
Samarium		182.38(11)	23(3)	358.27(11)	7.6(15)
334.02(5)	4790(60)	187.37(8)	31.2(14)	360.06(17)	5.1(4)
712.25(5)	268(4)	190.96(11)	19.7(14)	364.82(10)	7.8(5)
737.48(5)	598(8)	193.11(13)	28.3(20)	366.57(9)	8.8(7)
Europium		194.73(25)	11.7(20)	369.39(15)	5.9(8)
52.39(9)	55(3)	197.10(16)	14.1(14)	370.82(12)	8.3(5)
56.73(16)	16(6)	199.12(10)	25.5(15)	376.75(9)	8.4(5)
59.79(14)	10(3)	203.63(10)	18.4(14)	378.98(10)	6.5(4)
63.43(23)	12(5)	206.53(8)	58.7(20)	381.56(10)	5.3(5)
65.1(3)	16(8)	208.51(18)	16.1(21)	388.00(16)	4.3(6)
68.23(9)	69(20)	209.93(25)	8.5(24)	390.61(12)	8.7(7)
71.24(12)	45(14)	214.57(17)	13(3)	392.96(12)	7.5(6)
73.21(9)	106(22)	221.30(8)	73(3)	396.92(11)	7.5(6)
74.86(12)	43(12)	225.11(21)	11.2(23)	400.52(19)	4.2(6)
77.40(8)	187(13)	228.7(4)	5.6(22)	404.34(14)	9.6(9)
79.78(22)	12(6)	233.22(14)	15.9(23)	411.61(17)	5.3(7)
82.51(13)	7(5)	239.25(23)	12.4(25)	414.24(11)	9.1(8)
85.28(13)	9(5)	243.1(3)	12.2(20)	423.32(10)	13.1(10)
87.13(11)	29(3)	244.88(24)	26.3(22)	427.02(13)	8.0(9)
88.31(12)	42(5)	246.5(3)	15(3)	433.04(10)	10.3(11)

$E\gamma$ -keV	$\sigma_{\gamma}^z(E\gamma)$ -barns	$E\gamma$ -keV	$\sigma_{\gamma}^z(E\gamma)$ -barns	$E\gamma$ -keV	$\sigma_{\gamma}^z(E\gamma)$ -barns
438.1(3)	5.3(9)	93.06(8)	0.218(25)	350.99(10)	0.176(22)
440.83(24)	6.2(9)	94.55(12)	0.071(11)	352.37(10)	0.160(21)
444.6(3)	4.7(10)	97.36(8)	0.50(6)	356.22(11)	0.117(17)
449.85(20)	5.4(11)	101.16(15)	0.023(5)	357.64(8)	0.26(3)
472.38(12)	5.3(9)	103.80(9)	0.089(10)	359.90(16)	0.048(9)
526.49(11)	4.3(4)	108.69(14)	0.026(5)	361.61(10)	0.095(12)
5379.7(4)	9.2(19)	112.26(9)	0.089(10)	363.69(9)	0.120(15)
5500.68(18)	7.0(4)	117.76(12)	0.028(5)	369.90(8)	0.057(7)
5595.20(20)	5.3(4)	131.00(9)	0.064(8)	372.86(9)	0.070(8)
5816.5(8)	3.7(12)	135.44(8)	0.39(4)	374.51(8)	0.099(11)
6069.29(18)	8.2(7)	139.03(15)	0.052(6)	376.11(7)	0.154(16)
6229.7(7)	4.1(8)	141.06(11)	0.107(12)	378.60(8)	0.161(19)
Gadolinium		150.45(7)	0.144(15)	379.8(3)	0.024(8)
79.71(6)	4040(110)	153.52(7)	0.44(5)	399.42(11)	0.074(11)
89.17(6)	1380(40)	158.85(7)	0.111(12)	404.69(10)	0.127(17)
182.12(6)	7300(400)	163.02(7)	0.105(11)	414.66(16)	0.092(22)
199.42(6)	2000(600)	176.79(10)	0.070(9)	420.55(8)	0.092(12)
255.80(6)	373(30)	184.37(13)	0.11(3)	426.89(7)	0.147(17)
277.73(6)	495(12)	193.32(7)	0.37(4)	437.21(11)	0.077(16)
780.15(6)	1020(23)	209.61(8)	0.055(6)	441.73(13)	0.077(12)
870.85(6)	434(11)	212.38(12)	0.032(4)	447.20(17)	0.10(3)
897.66(5)	1080(50)	214.61(11)	0.036(5)	451.44(15)	0.21(3)
897.66(5)	1200(50)	220.96(12)	0.022(4)	453.14(22)	0.033(12)
915.11(6)	392(11)	228.09(9)	0.032(4)	455.4(3)	0.029(12)
944.70(10)	3080(70)	234.38(18)	0.026(5)	459.70(9)	0.085(12)
962.18(5)	1980(50)	235.88(14)	0.032(6)	464.28(7)	0.192(21)
977.22(5)	1420(30)	238.81(18)	0.023(5)	491.51(23)	0.024(6)
1003.97(7)	391(30)	241.64(20)	0.035(8)	497.07(15)	0.041(9)
1097.03(5)	660(16)	243.03(8)	0.219(24)	519.73(19)	0.059(13)
1107.51(6)	1840(40)	247.98(7)	0.30(3)	521.32(23)	0.046(12)
1116.52(5)	418(10)	255.39(12)	0.112(16)	525.65(8)	0.22(3)
1119.23(5)	1180(30)	257.81(14)	0.045(7)	529.24(6)	0.022(8)
1141.36(7)	474(30)	262.32(22)	0.022(6)	532.71(8)	0.129(16)
1184.32(7)	1160(120)	264.75(14)	0.031(7)	541.57(8)	0.121(15)
1186.75(5)	1550(190)	270.57(8)	0.102(12)	545.14(11)	0.064(10)
1186.75(5)	1600(190)	275.49(8)	0.124(14)	585.69(13)	0.054(8)
1259.91(5)	420(11)	277.64(9)	0.093(11)	600.02(7)	0.155(18)
1263.73(5)	644(16)	278.75(7)	0.083(11)	611.47(18)	0.034(9)
1323.48(5)	641(17)	282.86(12)	0.049(8)	625.64(16)	0.027(7)
5903.39(13)	453(14)	284.10(9)	0.087(11)	634.67(11)	0.037(7)
6750.05(14)	963(30)	288.07(7)	0.126(14)	5184.6(6)	0.023(9)
Terbium		290.41(9)	0.052(7)	5228.0(5)	0.052(12)
59.48(8)	0.48(6)	295.87(9)	0.062(8)	5238.6(7)	0.026(10)
61.59(25)	0.052(15)	302.75(8)	0.086(10)	5245.4(6)	0.061(13)
63.74(8)	1.46(16)	308.04(9)	0.056(8)	5288.8(5)	0.027(7)
65.94(15)	0.090(17)	310.46(8)	0.177(21)	5460.9(5)	0.029(7)
68.25(24)	0.035(14)	315.81(8)	0.118(14)	5524.3(4)	0.051(13)
74.89(8)	1.78(18)	317.42(8)	0.121(15)	5608.1(6)	0.042(9)
76.77(12)	0.089(12)	319.75(8)	0.132(15)	5661.3(5)	0.037(7)
79.28(8)	0.43(6)	339.35(7)	0.35(4)	5684.4(6)	0.027(7)
84.21(14)	0.050(10)	341.01(9)	0.069(9)	5754.6(4)	0.031(8)
87.46(9)	0.160(19)	345.29(8)	0.128(16)	5776.2(3)	0.120(17)
89.04(9)	0.21(3)	348.61(13)	0.053(10)	5784.1(4)	0.041(9)

$E\gamma$ -keV	$\sigma_{\gamma}^z(E\gamma)$ -barns	$E\gamma$ -keV	$\sigma_{\gamma}^z(E\gamma)$ -barns	$E\gamma$ -keV	$\sigma_{\gamma}^z(E\gamma)$ -barns
5842.1(11)	0.054(10)	5557.15(17)	28.7(14)	235.12(5)	1.18(4)
5860.8(10)	0.036(8)	5607.73(18)	35.9(16)	237.19(5)	5.52(10)
5891.2(3)	0.137(19)	Holmium		242.58(5)	1.28(4)
5896.0(6)	0.023(7)	69.79(4)	1.09(6)	310.97(5)	2.50(5)
5953.5(3)	0.103(13)	116.84(4)	8.1(4)	352.91(6)	0.547(23)
5993.8(3)	0.114(15)	136.67(4)	14.5(7)	384.04(5)	1.95(5)
6138.4(3)	0.110(15)	149.32(4)	2.25(12)	400.21(5)	0.717(19)
6218.5(3)	0.190(22)	180.96(5)	0.94(5)	411.46(5)	2.37(5)
6240.8(3)	0.072(10)	221.18(4)	2.05(11)	424.61(5)	0.556(25)
6268.7(4)	0.029(6)	239.13(4)	2.25(12)	442.06(8)	0.51(4)
6311.9(7)	0.028(6)	289.04(4)	1.16(6)	446.31(5)	1.62(4)
Dysprosium		290.61(4)	0.96(5)	455.96(6)	1.16(4)
50.44(7)	33.9(15)	304.63(4)	1.34(7)	457.23(11)	0.557(25)
80.64(7)	12.0(4)	333.61(4)	1.04(6)	468.62(7)	0.45(4)
108.23(7)	15.6(5)	371.74(4)	1.56(8)	472.94(8)	0.60(5)
184.34(7)	146(15)	401.57(4)	1.07(9)	496.52(5)	0.80(3)
185.19(9)	33.8(9)	410.45(4)	1.23(7)	499.32(5)	0.88(3)
260.11(7)	8.3(3)	425.90(4)	2.88(15)	505.00(6)	0.90(3)
282.89(7)	7.8(3)	455.53(4)	0.78(4)	506.61(6)	0.84(3)
349.14(8)	14.7(6)	489.45(4)	1.15(6)	510.43(11)	0.61(3)
351.20(8)	10.9(5)	542.74(4)	1.94(13)	512.01(5)	1.96(5)
386.08(7)	34.8(10)	543.69(4)	1.00(5)	523.32(7)	0.48(3)
389.83(8)	7.3(4)	Erbium		532.39(6)	0.59(3)
392.66(7)	11.3(5)	99.07(3)	3.73(14)	535.78(5)	1.18(4)
411.71(7)	35.1(10)	184.301(25)	56(5)	537.97(6)	1.00(4)
415.03(7)	30.8(9)	198.267(24)	29.9(16)	562.39(5)	0.85(3)
421.10(10)	11.8(11)	284.71(3)	13.7(12)	565.22(5)	1.58(4)
447.96(7)	17.4(5)	447.556(24)	3.07(11)	569.25(5)	1.02(3)
465.46(7)	38.0(10)	631.709(19)	7.9(3)	585.09(6)	0.60(4)
470.25(8)	9.3(6)	730.649(19)	11.6(4)	589.13(10)	0.58(10)
477.10(7)	15.8(5)	741.372(20)	6.72(24)	590.18(7)	1.27(10)
496.96(7)	44.9(11)	816.003(23)	42.5(15)	603.91(5)	1.40(5)
499.43(9)	13.0(10)	821.20(3)	6.2(3)	611.80(8)	0.83(4)
500.62(9)	10.3(5)	830.01(4)	4.12(19)	632.37(6)	0.74(3)
509.06(9)	9.5(6)	853.505(20)	7.5(3)	637.75(4)	1.25(4)
510.81(14)	8.5(7)	914.952(20)	6.99(24)	640.56(8)	0.70(3)
515.33(7)	9.7(5)	1277.57(8)	2.82(16)	650.21(6)	1.45(5)
538.65(7)	69.2(19)	Thulium		658.85(5)	1.56(5)
570.05(9)	9.7(5)	66.06(10)	0.51(10)	703.71(5)	1.32(4)
584.00(7)	25.7(7)	68.54(6)	1.75(23)	710.70(7)	0.60(3)
807.46(7)	12.1(5)	75.23(9)	0.94(8)	719.12(8)	1.01(3)
882.27(6)	18.3(6)	87.44(5)	1.29(3)	720.61(8)	0.57(3)
888.13(7)	10.4(5)	105.11(6)	0.780(23)	724.48(5)	0.68(3)
911.99(7)	16.0(7)	114.50(5)	3.19(6)	815.56(5)	0.76(3)
979.98(9)	8.5(4)	129.99(5)	0.940(25)	854.23(5)	1.41(4)
994.64(7)	9.2(4)	144.43(5)	5.96(11)	1178.65(9)	0.56(4)
2947.66(19)	10.8(7)	149.66(5)	7.11(12)	4732.63(22)	0.58(5)
3012.35(13)	7.8(5)	165.69(5)	3.29(6)	5158.2(4)	0.47(5)
3035.56(12)	10.9(6)	180.92(5)	3.85(14)	5737.50(20)	1.42(7)
3114.14(15)	7.4(6)	198.46(5)	0.96(3)	5908.3(3)	0.49(4)
3443.43(14)	10.6(16)	204.41(5)	8.72(19)	5943.14(20)	1.51(7)
4123.88(15)	13.1(9)	219.65(5)	3.64(6)	6001.51(22)	0.99(10)
5144.00(22)	15.7(10)	231.71(6)	0.60(3)	6387.49(22)	1.48(7)

Eγ-keV	$\sigma_{\gamma}^z(\text{E}\gamma)$-barns	Eγ-keV	$\sigma_{\gamma}^z(\text{E}\gamma)$-barns	Eγ-keV	$\sigma_{\gamma}^z(\text{E}\gamma)$-barns
6442.19(23)	0.47(3)	214.38(7)	20.6(4)	616.14(9)	0.059(3)
Ytterbium		215.37(8)	2.82(16)	657.42(13)	0.083(5)
180.23(5)	0.52(5)	303.98(6)	4.29(9)	694.27(9)	0.073(3)
363.33(3)	0.89(9)	325.55(6)	6.89(15)	745.76(10)	0.053(3)
428.28(3)	0.59(6)	1066.04(6)	1.96(5)	782.13(9)	0.143(6)
435.88(3)	0.53(5)	1077.71(6)	2.40(6)	788.69(11)	0.070(5)
477.23(3)	0.71(7)	1081.35(6)	2.82(7)	791.86(9)	0.113(6)
514.87(3)	9.0(9)	1102.72(6)	2.96(8)	816.24(9)	0.104(4)
534.83(3)	0.49(5)	1143.66(6)	1.84(6)	840.03(8)	0.143(5)
639.73(3)	1.45(15)	1167.02(6)	3.95(10)	866.24(9)	0.068(3)
5284.9(5)	1.49(15)	1174.77(8)	4.8(7)	888.17(9)	0.079(4)
Lutetium		1175.65(11)	2.6(5)	891.42(9)	0.136(5)
71.46(7)	3.96(16)	1205.93(13)	1.47(23)	894.52(9)	0.078(4)
93.97(8)	0.71(4)	1207.11(7)	3.9(3)	903.16(9)	0.113(4)
111.65(7)	1.02(5)	1229.19(6)	4.26(11)	908.82(9)	0.092(4)
112.83(7)	1.16(5)	1269.27(6)	2.26(7)	979.58(9)	0.104(4)
119.70(7)	1.12(5)	1329.72(6)	2.09(7)	1026.17(8)	0.164(6)
121.54(7)	5.20(17)	1333.66(6)	1.73(7)	1070.98(10)	0.053(3)
138.57(6)	6.76(25)	1340.41(6)	2.40(8)	1082.03(10)	0.061(4)
144.65(7)	1.34(8)	1420.57(7)	1.83(7)	1274.51(9)	0.130(5)
145.84(9)	1.51(9)	5723.90(15)	2.52(11)	3469.42(13)	0.103(6)
147.15(6)	4.96(19)	Tantalum		3492.76(17)	0.051(4)
150.34(6)	13.7(4)	97.77(7)	12.6(6)	3534.66(16)	0.063(5)
162.44(6)	5.29(17)	133.89(6)	57(6)	3561.02(14)	0.060(4)
168.61(7)	0.95(5)	146.80(6)	12.7(4)	3739.00(16)	0.069(4)
171.80(6)	1.73(6)	156.12(6)	21.1(5)	3847.35(17)	0.051(4)
185.49(6)	3.40(12)	173.22(6)	109.0(23)	4014.64(16)	0.055(4)
188.01(6)	1.40(6)	190.34(6)	16.5(6)	4118.85(16)	0.059(4)
192.00(6)	2.09(8)	270.48(6)	235(5)	4249.36(18)	0.115(6)
201.58(7)	0.79(6)	297.19(6)	56.4(15)	4384.34(21)	0.057(5)
207.77(7)	1.02(5)	360.60(6)	16.0(6)	4574.19(18)	0.104(9)
225.34(6)	1.73(6)	402.70(5)	106.0(21)	4626.40(15)	0.124(7)
235.83(6)	0.82(4)	511.85(9)	14.9(8)	4650.6(3)	0.052(5)
259.35(6)	1.89(8)	5964.90(14)	12.5(7)	4684.37(14)	0.150(7)
263.29(9)	0.72(9)	Tungsten		5164.24(14)	0.226(9)
264.28(9)	0.77(9)	111.11(9)	0.162(4)	6144.21(18)	0.186(12)
268.75(5)	3.64(13)	127.46(9)	0.129(5)	6190.60(17)	0.513(18)
284.54(6)	0.75(4)	145.74(9)	0.970(21)	7412.02(24)	0.072(4)
301.10(6)	0.74(4)	162.21(9)	0.187(5)	Rhenium	
310.13(5)	1.49(6)	201.42(9)	0.319(8)	74.76(5)	1.29(8)
318.98(5)	3.83(13)	204.80(9)	0.148(4)	87.20(4)	0.84(4)
335.81(5)	1.32(6)	226.13(10)	0.113(17)	92.33(5)	1.14(6)
347.96(6)	0.85(4)	252.93(9)	0.101(3)	99.36(7)	0.230(24)
367.38(5)	2.22(8)	273.02(9)	0.272(7)	103.16(5)	0.43(3)
413.66(5)	0.94(4)	289.93(9)	0.0603(22)	105.82(4)	1.91(8)
457.94(4)	8.3(3)	313.14(9)	0.054(4)	107.40(7)	0.352(25)
761.64(4)	2.63(10)	423.92(9)	0.0497(22)	111.50(4)	1.80(7)
838.99(7)	0.90(5)	473.85(10)	0.055(5)	114.85(6)	0.43(5)
1080.25(6)	0.69(4)	499.96(9)	0.0491(23)	122.53(5)	0.74(4)
1088.06(5)	0.84(4)	531.19(9)	0.052(3)	127.67(7)	0.43(4)
Hafnium		557.11(9)	0.125(5)	130.83(7)	0.43(3)
63.16(6)	5.26(14)	577.25(8)	0.191(5)	139.32(12)	0.43(5)
213.43(6)	29.4(6)	611.23(9)	0.066(3)	141.52(5)	1.46(8)

$E\gamma$ -keV	$\sigma_{\gamma}^z(E\gamma)$ -barns	$E\gamma$ -keV	$\sigma_{\gamma}^z(E\gamma)$ -barns	$E\gamma$ -keV	$\sigma_{\gamma}^z(E\gamma)$ -barns
144.03(6)	1.85(9)	5073.41(24)	0.43(5)	151.51(6)	2.89(20)
145.45(16)	0.44(5)	5137.4(4)	0.39(4)	156.38(6)	2.76(12)
147.36(11)	0.47(5)	5871.62(21)	0.299(23)	162.52(13)	0.63(13)
149.28(11)	0.44(5)	5910.21(21)	0.60(4)	165.41(18)	1.7(7)
151.38(6)	1.15(7)	Osmium		169.25(5)	3.05(13)
156.59(10)	0.73(8)	73.43(4)	0.174(8)	177.00(18)	0.6(4)
167.30(4)	1.46(6)	155.18(3)	1.19(3)	178.91(8)	2.1(5)
174.21(5)	0.382(24)	175.80(4)	0.189(8)	183.35(14)	1.0(4)
176.34(8)	0.31(3)	186.85(3)	2.08(5)	184.67(16)	0.92(22)
177.70(13)	0.26(3)	235.24(3)	0.184(6)	193.59(8)	1.31(24)
181.92(5)	0.388(25)	272.87(3)	0.242(6)	197.12(21)	0.73(19)
188.82(5)	1.11(5)	275.34(3)	0.173(5)	199.02(10)	1.07(18)
190.05(12)	0.284(24)	323.02(4)	0.242(9)	201.48(9)	1.36(17)
193.29(5)	0.43(3)	361.19(3)	0.466(15)	203.83(8)	1.67(12)
199.44(5)	0.91(4)	371.35(3)	0.574(14)	206.19(6)	3.70(18)
205.18(13)	0.37(8)	397.50(5)	0.115(5)	208.07(16)	0.70(9)
207.92(4)	4.44(21)	407.45(3)	0.134(5)	210.74(10)	2.1(4)
210.59(7)	1.50(10)	478.11(3)	0.523(14)	211.49(5)	0.6(3)
214.62(5)	2.53(14)	527.60(3)	0.300(10)	215.37(15)	0.74(9)
216.76(22)	0.30(7)	537.75(4)	0.121(6)	216.75(5)	5.57(24)
219.34(8)	0.67(9)	558.02(3)	0.84(3)	222.36(10)	0.83(16)
223.09(17)	0.24(6)	569.38(3)	0.694(25)	226.23(14)	4.0(4)
227.04(5)	1.78(12)	605.34(3)	0.113(4)	231.64(8)	0.95(13)
232.07(13)	0.36(7)	633.12(3)	0.585(16)	241.70(15)	0.65(13)
236.59(5)	1.45(10)	634.99(4)	0.405(12)	245.60(8)	1.05(10)
251.45(6)	1.80(23)	829.34(4)	0.167(6)	248.07(18)	0.9(3)
252.12(11)	0.58(16)	5146.63(14)	0.409(20)	250.63(8)	0.87(10)
254.94(4)	1.15(5)	5277.11(22)	0.116(15)	254.29(9)	1.08(11)
257.15(6)	1.52(22)	5683.87(21)	0.167(13)	259.11(8)	1.29(18)
261.13(4)	0.67(3)	Iridium		262.01(6)	3.05(18)
262.71(6)	0.267(17)	58.83(6)	5.3(3)	263.90(11)	1.39(13)
274.30(8)	0.80(6)	63.19(5)	70(3)	267.35(9)	0.93(21)
275.51(11)	0.51(4)	64.81(5)	121(4)	270.79(12)	0.86(20)
284.88(8)	0.41(4)	66.62(9)	3.22(23)	273.23(17)	0.72(17)
290.66(6)	3.5(4)	71.54(20)	0.6(3)	274.88(16)	0.74(16)
300.03(6)	0.70(5)	73.35(5)	42.7(15)	278.33(7)	1.95(16)
307.60(9)	0.34(3)	77.79(5)	4.8(4)	284.29(7)	1.95(15)
316.43(4)	2.21(10)	84.21(5)	7.7(4)	294.16(13)	1.12(17)
318.82(16)	0.25(3)	86.75(7)	0.65(13)	297.51(23)	0.65(17)
358.19(8)	0.236(19)	88.64(5)	3.67(24)	300.05(7)	1.07(12)
360.24(5)	0.449(25)	90.65(5)	1.25(15)	302.91(7)	1.20(11)
362.82(5)	0.46(3)	95.37(6)	0.9(3)	308.23(9)	1.45(11)
378.35(4)	0.54(3)	107.94(5)	2.62(12)	310.04(19)	0.61(10)
390.80(4)	1.15(5)	110.65(7)	1.18(8)	315.94(9)	2.4(4)
518.34(19)	0.24(6)	112.12(6)	1.69(10)	333.79(6)	1.53(10)
607.24(18)	0.25(3)	118.38(8)	0.89(13)	337.48(7)	0.96(9)
608.72(17)	0.25(3)	124.41(8)	1.12(13)	340.48(12)	0.72(9)
680.49(10)	0.34(3)	126.88(5)	1.86(10)	351.59(5)	10.9(4)
795.02(12)	0.31(3)	136.20(5)	11.5(4)	365.02(13)	1.15(10)
4663.71(23)	0.24(3)	138.43(10)	1.29(10)	371.34(6)	2.11(12)
4860.7(3)	0.37(4)	140.01(10)	0.95(9)	417.99(5)	3.45(15)
5007.0(3)	0.27(4)	144.79(6)	3.95(19)	432.55(5)	1.85(7)
5027.89(23)	0.29(5)	148.85(6)	2.33(14)	459.46(7)	1.44(9)

Eγ-keV	$\sigma_{\gamma}^z(\text{E}\gamma)$-barns	Eγ-keV	$\sigma_{\gamma}^z(\text{E}\gamma)$-barns	Eγ-keV	$\sigma_{\gamma}^z(\text{E}\gamma)$-barns
461.97(10)	0.78(7)	204.15(4)	0.513(8)	1202.25(7)	15.9(4)
486.87(10)	0.93(13)	215.01(3)	7.77(8)	1205.67(7)	17.8(6)
4531.38(22)	0.61(5)	219.42(5)	0.42(3)	1225.51(4)	16.3(4)
4867.01(17)	0.68(4)	247.63(3)	5.56(6)	1262.96(4)	28.5(6)
4980.43(17)	0.82(4)	261.36(3)	6.3(3)	1273.52(4)	14.0(4)
4985.92(18)	0.58(3)	271.35(9)	0.42(6)	1407.94(4)	12.6(3)
5020.66(19)	0.66(6)	291.77(4)	1.48(3)	1570.32(4)	39.1(9)
5028.44(18)	0.67(6)	307.73(4)	0.607(21)	1693.31(4)	74.4(21)
5129.20(16)	0.90(5)	311.95(4)	0.627(25)	2002.03(5)	32.2(12)
5147.51(15)	1.29(6)	328.49(3)	2.09(4)	2639.67(5)	15.3(4)
5166.97(16)	0.96(6)	343.62(3)	1.080(20)	3185.77(6)	15.0(5)
5219.77(21)	0.72(5)	346.86(5)	0.58(5)	3288.75(6)	17.6(5)
5283.60(17)	0.85(6)	350.79(4)	1.30(7)	4675.64(9)	17.2(5)
5304.48(18)	0.73(5)	355.53(4)	0.460(21)	4739.44(8)	39.8(10)
5327.56(21)	0.71(5)	371.05(4)	0.572(18)	4759.06(9)	16.4(5)
5357.49(17)	1.03(6)	381.22(3)	4.22(6)	4842.44(9)	26.5(8)
5431.36(17)	0.78(4)	418.90(3)	1.060(21)	5050.06(9)	26.5(8)
5458.96(22)	0.60(5)	439.77(8)	1.49(23)	5388.48(10)	23.1(6)
5467.0(3)	0.59(7)	440.66(13)	0.69(15)	5658.17(10)	36.4(9)
5487.39(22)	0.58(4)	444.35(4)	0.83(3)	5967.00(10)	82.7(20)
5517.18(19)	0.76(4)	449.54(4)	0.646(24)	6457.78(12)	30.5(10)
5534.73(17)	1.39(6)	456.23(5)	0.57(3)	Thallium	
5564.68(17)	1.71(8)	458.15(5)	0.59(3)	139.94(9)	0.400(7)
5570.03(22)	0.67(4)	498.53(5)	0.457(25)	154.01(9)	0.0926(17)
5595.77(17)	0.72(4)	511.50(8)	1.26(9)	198.33(8)	0.0408(10)
5612.60(17)	1.06(5)	515.92(5)	0.57(3)	265.86(9)	0.0210(7)
5667.81(16)	2.68(10)	529.30(4)	2.80(17)	292.26(8)	0.0983(20)
5689.23(16)	1.73(7)	540.27(4)	0.60(4)	304.86(9)	0.0225(12)
5728.93(17)	1.15(5)	543.97(4)	0.54(3)	310.31(9)	0.0245(12)
5782.85(18)	1.34(6)	548.91(4)	0.85(5)	318.88(8)	0.325(6)
5866.76(19)	0.79(5)	565.72(6)	0.43(5)	325.85(8)	0.0301(10)
5954.4(3)	0.74(4)	571.62(5)	0.61(7)	330.09(9)	0.0267(10)
5958.09(23)	1.79(8)	625.35(5)	0.45(3)	330.09(9)	0.0267(10)
5962.25(23)	0.75(4)	640.55(5)	0.59(4)	331.76(9)	0.0371(10)
6082.02(18)	2.62(11)	672.72(3)	0.635(17)	347.96(8)	0.361(10)
Platinum		702.22(3)	0.565(7)	383.99(8)	0.0341(12)
326.20(4)	0.511(10)	835.81(5)	0.758(23)	395.62(8)	0.0862(20)
332.84(4)	2.580(25)	4799.83(5)	0.996(23)	424.81(8)	0.1200(25)
355.54(4)	6.17(6)	4852.60(9)	0.406(18)	471.90(8)	0.116(3)
521.02(4)	0.336(10)	4898.11(9)	0.411(17)	488.11(8)	0.096(4)
5254.41(19)	0.397(11)	4905.79(9)	0.423(17)	563.21(8)	0.0356(15)
Gold		4957.67(6)	0.95(3)	591.13(9)	0.0225(10)
55.11(3)	2.90(12)	4998.64(8)	0.530(20)	624.46(8)	0.0413(10)
74.94(4)	0.390(18)	5086.25(7)	0.607(16)	626.54(8)	0.0388(10)
97.24(3)	4.51(6)	5102.64(5)	1.110(23)	629.12(8)	0.0388(10)
101.93(3)	0.953(17)	5140.69(8)	0.395(14)	678.01(8)	0.0361(15)
146.44(4)	0.43(3)	5148.64(9)	0.500(15)	732.09(9)	0.064(3)
158.44(3)	1.250(14)	5226.41(8)	0.450(18)	737.12(8)	0.118(5)
168.36(3)	3.53(4)	5279.40(7)	0.524(16)	764.13(9)	0.0316(12)
170.17(3)	1.510(17)	5354.86(7)	0.401(13)	818.14(8)	0.0279(10)
180.83(5)	0.53(4)	Mercury		873.16(8)	0.168(4)
188.17(5)	0.51(4)	367.96(3)	251(5)	931.39(8)	0.0257(12)
192.55(4)	4.6(3)	661.39(3)	29.5(6)	949.88(8)	0.0479(15)

$E\gamma$ -keV	$\sigma_{\gamma}^z(E\gamma)$ -barns	$E\gamma$ -keV	$\sigma_{\gamma}^z(E\gamma)$ -barns	$E\gamma$ -keV	$\sigma_{\gamma}^z(E\gamma)$ -barns
1013.27(9)	0.0217(12)	2505.31(8)	0.0021(3)	872.13(11)	0.0268(15)
1093.02(8)	0.0353(12)	2598.28(9)	0.00166(24)	968.78(9)	0.132(6)
1110.37(8)	0.0413(12)	2624.22(8)	0.00154(21)	1013.84(11)	0.037(3)
1121.29(7)	0.0600(17)	2828.27(8)	0.00179(24)	1034.27(11)	0.0165(14)
1155.43(7)	0.0605(17)	3080.67(10)	0.00145(20)	1100.98(11)	0.0211(16)
1234.69(7)	0.0746(25)	3356.53(11)	0.00167(24)	2703.55(24)	0.014(5)
1478.77(8)	0.0544(22)	3396.18(11)	0.00170(24)	2719.67(18)	0.016(3)
1741.01(8)	0.0548(25)	3632.83(12)	0.00136(20)	2824.9(3)	0.0144(22)
1756.27(12)	0.027(3)	4054.32(10)	0.0137(18)	3148.23(10)	0.0208(14)
4115.08(17)	0.0222(17)	4101.62(11)	0.0089(12)	3196.66(12)	0.0171(13)
4195.98(14)	0.0373(22)	4165.44(14)	0.00173(24)	3287.94(14)	0.0165(14)
4225.47(17)	0.045(3)	4170.96(11)	0.0171(22)	3341.90(13)	0.0168(13)
4309.00(24)	0.0210(22)	4256.42(13)	0.0024(3)	3398.09(13)	0.0191(14)
4343.56(12)	0.034(3)	Thorium		3436.17(12)	0.0211(15)
4402.60(15)	0.0208(15)	77.09(15)	0.09(3)	3448.42(10)	0.0233(16)
4495.74(13)	0.043(4)	211.86(11)	0.0191(17)	3473.00(8)	0.057(3)
4540.62(15)	0.0413(25)	229.08(11)	0.0163(13)	3509.43(14)	0.0170(14)
4600.95(16)	0.0292(22)	256.25(11)	0.093(17)	3530.96(13)	0.0397(24)
4687.58(12)	0.098(4)	277.48(11)	0.0312(25)	3946.42(10)	0.0268(15)
4705.83(14)	0.058(3)	281.40(11)	0.0170(14)	Uranium	
4752.24(11)	0.148(5)	311.91(10)	0.0187(10)	521.89(5)	0.072(3)
4841.40(15)	0.090(4)	316.64(10)	0.0397(18)	551.808(22)	0.207(5)
4913.57(11)	0.164(5)	319.08(10)	0.082(3)	909.06(6)	0.026(4)
4980.97(20)	0.036(3)	327.80(10)	0.0269(16)	943.14(7)	0.082(10)
5014.61(15)	0.058(3)	329.88(11)	0.0221(17)		
5130.50(23)	0.058(4)	331.37(11)	0.0291(19)		
5180.38(12)	0.141(5)	335.92(10)	0.089(4)		
5261.48(13)	0.084(4)	354.27(10)	0.0408(20)		
5279.86(12)	0.207(6)	472.30(10)	0.165(8)		
5404.41(12)	0.147(5)	522.73(10)	0.102(5)		
5451.07(14)	0.079(3)	531.58(10)	0.0404(23)		
5533.35(13)	0.131(5)	539.66(10)	0.061(3)		
5603.28(13)	0.282(10)	548.23(11)	0.042(10)		
5641.57(12)	0.316(7)	556.93(11)	0.040(10)		
5917.48(16)	0.084(4)	561.25(11)	0.033(8)		
6025.21(24)	0.0222(25)	566.63(10)	0.19(5)		
6118.79(23)	0.0232(20)	578.02(9)	0.105(5)		
6166.61(14)	0.166(6)	583.27(9)	0.279(11)		
6183.05(15)	0.081(4)	586.02(10)	0.045(3)		
6222.57(16)	0.065(4)	593.23(10)	0.043(3)		
6336.11(22)	0.0245(22)	605.41(10)	0.054(4)		
6514.57(15)	0.129(5)	612.45(9)	0.018(3)		
Lead		659.56(16)	0.0173(20)		
6737.53(14)	0.00691(19)	665.11(10)	0.084(4)		
7367.83(12)	0.137(3)	681.81(9)	0.079(4)		
Bismuth		705.17(11)	0.050(4)		
162.34(4)	0.00162(21)	714.23(10)	0.052(3)		
319.83(4)	0.0115(14)	752.05(16)	0.0142(19)		
673.99(4)	0.0026(4)	797.79(9)	0.0416(20)		
774.95(5)	0.00141(20)	808.53(11)	0.0212(14)		
808.79(4)	0.00119(16)	814.75(10)	0.0196(13)		
900.21(6)	0.00102(14)	834.83(14)	0.059(5)		
1337.07(5)	0.00156(21)	860.61(13)	0.047(5)		

ENSDF THERMAL NEUTRON CAPTURE GAMMA-RAY REFERENCES

The ENSDF database contains one to three primary references for each thermal neutron capture dataset that indicate the main literature sources. Additional references are included in the dataset and can be found in the original ENSDF-formatted files on the accompanying CD-ROM. Each reference is assigned an 8-digit keynumber specifying the publication year, first two initials of the first author's last name, and an arbitrary sequence code. Reference keynumbers for all of the primary ENSDF references used in this report are summarized in the following table. The complete citations for each reference follow the keynumber table

<u>Isotope</u>	<u>NSR Reference Keynumber(s)</u>	<u>Isotope</u>	<u>NSR Reference Keynumber(s)</u>
¹ H	1994Ki27,1982Va13,1980Is02	⁴⁶ Ca	1970Cr04
² H	1982Ju01,1980Al31	⁴⁸ Ca	1970Cr04,1969ArZT
⁶ Li	1985Ko47	⁴⁵ Sc	1982Ti02
⁷ Li	1991Ly01	⁴⁶ Ti	1972Kn07
⁹ Be	1983Ke11,1974JuZW	⁴⁷ Ti	1989Co01,1984Ru06
¹⁰ B	1986Ko19	⁴⁸ Ti	1992Ku17,1983Ru08
¹² C	1982Mu14	⁴⁹ Ti	1984Ru06,1971Te01
¹³ C	1982Mu14	⁵⁰ Ti	1971Ar39
¹⁴ N	1997Ju02,1994Ra17,1990Is05	⁵⁰ V	1991Mi08,1978Ro03,1973HaWJ
¹⁶ O	1977Mc05	⁵¹ V	1991Mi08
¹⁷ O	1978LoZW,1978LoZT	⁵⁰ Cr	1974KoYY,1972Ko15,1972Lo26
¹⁹ F	1996Ra04	⁵² Cr	1980Ko01,1972Ko15
²⁰ Ne	1986Pr05	⁵³ Cr	1989Ho15,1988Li30,1994Co09
²¹ Ne	1986Pr05	⁵⁴ Cr	1972Wh05
²² Ne	1986Pr05	⁵⁵ Mn	1980De20,1975Co05,1974Bo19
²³ Na	1983Hu11,1983Ti02	⁵⁴ Fe	1972Ko15,1967Ar14,1990Ku26
²⁴ Mg	1992Wa06,1991MiZQ	⁵⁶ Fe	1980Ve05,1978Ve06,1969Ko05
²⁵ Mg	1992Wa06,1991Ki04	⁵⁷ Fe	1969Fa05,1973Ko27
²⁶ Mg	1992Wa06	⁵⁸ Fe	1983VeZZ,1980Ve05,1978Ve06
²⁷ Al	1982Sc14	⁵⁹ Co	1984Ko29
²⁸ Si	1992Ra19,1990Is02	⁵⁸ Ni	1993Ha05,1977Is01,1972St06
²⁹ Si	1992Ra19,1990Is02	⁶⁰ Ni	1993Ha05
³⁰ Si	1992Ra19,1990Is02	⁶¹ Ni	1970Fa06,1975Wi06
³¹ P	1989Mi16,1985Ke11	⁶² Ni	1977Is01,1970GaZQ,1972Ko15
³² S	1985Ra15	⁶⁴ Ni	1977Is01
³³ S	1985Ra15	⁶³ Cu	1983De28
³⁴ S	1985Ra15	⁶⁵ Cu	1983De29
³⁶ S	1984Ra09,1997Be42	⁶⁴ Zn	1972Bo75
³⁵ Cl	1982Kr12,1985Ke04,1996Co16	⁶⁶ Zn	1971Kn06,1975DeYM,1970Ba21
³⁷ Cl	1973Sp06	⁶⁷ Zn	1971Ot01
³⁶ Ar	1970Ha56	⁶⁸ Zn	1972Bo75
⁴⁰ Ar	1970Ha56	⁶⁹ Ga	1967Ba79,1970Li04,1971Ve03
³⁹ K	1984Vo01	⁷¹ Ga	1970Li04,1971Ve03
⁴⁰ K	1984Kr05	⁷⁰ Ge	1991Is01,1972Gr34,1972We10
⁴¹ K	1985Kr06	⁷² Ge	1972Gr34,1972Ha74,1972We10
⁴⁰ Ca	1967Gr16,1970Cr04	⁷³ Ge	1985HoZQ,1991Is01
⁴² Ca	1969Gr08	⁷⁴ Ge	1972Gr34,1972Ha74,1991Is01
⁴³ Ca	1972Wh02	⁷⁶ Ge	1972Gr34,1972Ha74
⁴⁴ Ca	1968Gr11	⁷⁵ As	1990Ho10

Isotope	NSR Reference Keynumber(s)	Isotope	NSR Reference Keynumber(s)
⁷⁴ Se	1984To11,1982ToZS,1981En07	¹³⁰ Te	1980Ho29,1977RuZR
⁷⁶ Se	1982ToZS,1985To10	¹²⁷ I	1991Sa07
⁷⁷ Se	1987Su05,1981En07,1979BrZE	¹²⁹ Xe	1988Ha28,1971Gr28
⁷⁸ Se	1979BrZE,1970Ba54,1981En07	¹³¹ Xe	1988Ha28,1971Gr28
⁸⁰ Se	1971Ra07	¹³⁶ Xe	1977Pr07
⁷⁹ Br	1978Do06,1977DoZP	¹³³ Cs	1987Bo24
⁸¹ Br	1978Do06	¹³⁴ Ba	1993Bo01
⁸³ Kr	1987Ha21,1972Ma42	¹³⁵ Ba	1990Is07,1983BrZK,1969Ge07
⁸⁶ Kr	1977Je03	¹³⁶ Ba	1995Bo03
⁸⁵ Rb	1969Da15,1969Ra10,1968Ir02	¹³⁷ Ba	1995Bo05
⁸⁶ Sr	1986Wi16	¹³⁸ Ba	1969Mo13
⁸⁷ Sr	1987Wi15	¹³⁹ La	1970Ju04,1988BoZH,1990Is09
⁸⁸ Sr	1989Wi05	¹³⁶ Ce	1981KoZW
⁸⁹ Y	1993Mi04	¹³⁸ Ce	1969Gr31
⁹⁰ Zr	1978LoZX	¹⁴⁰ Ce	1970Ge03
⁹¹ Zr	1979HeZT,1972FaZW	¹⁴² Ce	1976Ge02
⁹² Zr	1977Ba33	¹⁴¹ Pr	1985AlZN,1981Ke11,1968Ke08
⁹⁴ Zr	1977Ba33,1976BaYM	¹⁴² Nd	1976Mi19,1993Bo29
⁹³ Nb	1985Bo48,1968Ju01	¹⁴³ Nd	1983Sn04
¹⁰⁰ Mo	1990Se17	¹⁴⁴ Nd	1975Hi03
⁹² Mo	1991Is05	¹⁴⁵ Nd	1983Sn01,1976Bu14
⁹⁴ Mo	1973Ba57	¹⁴⁶ Nd	1975Ro16,1976Ro03
⁹⁵ Mo	1970He27	¹⁴⁸ Nd	1976Pi04
⁹⁶ Mo	1973De39	¹⁵⁰ Nd	1975SmZT,1976Pi13,1985BuZU
⁹⁷ Mo	1971He10	¹⁴⁴ Sm	1978WaZM
⁹⁸ Mo	1973De39	¹⁴⁷ Sm	1971Gr37,1993Ju01
⁹⁹ Tc	1979Pi08	¹⁴⁸ Sm	1982Ba15
⁹⁹ Ru	1988Co18,1988CoZU,1991Is05	¹⁴⁹ Sm	1966Sm03,1963Gr18,1969Re11
¹⁰⁰ Ru	1982Ba69	¹⁵⁰ Sm	1986Va08
¹⁰¹ Ru	1991Is05	¹⁵² Sm	1963Gr18,1969Sm04,1971Be41
¹⁰² Ru	1979SeZT	¹⁵⁴ Sm	1982Sc03
¹⁰⁴ Ru	1978Gu14,1974Hr01	¹⁵¹ Eu	1978Vo05
¹⁰³ Rh	1981Ke03	¹⁵³ Eu	1987Ba52,1978PrZY,1984Ro06
¹⁰² Pd	1970Bo29	¹⁵² Gd	1996SpZZ
¹⁰⁴ Pd	1970Bo29	¹⁵⁴ Gd	1986Sc25
¹⁰⁵ Pd	1987Co03,1970Or05	¹⁵⁵ Gd	1982Ba28
¹⁰⁸ Pd	1980Ca02	¹⁵⁶ Gd	1993Ko01,1986GrZR,1971Gr42
¹⁰⁷ Ag	1985Ma54	¹⁵⁷ Gd	1978Gr14,1970Bo29,1994GrZZ
¹⁰⁹ Ag	1979Bo41	¹⁵⁸ Gd	1971Gr42
¹¹⁰ Cd	1987BaYW,1991NeZX	¹⁶⁰ Gd	1971Gr42
¹¹¹ Cd	1993De01	¹⁵⁹ Tb	1974Ke01,1989Du03
¹¹³ Cd	1984Mh01,1979Br25,1968Gr32	¹⁶⁰ Dy	1977Be03
¹¹³ In	1975Ra07	¹⁶¹ Dy	1995Be02,1967Ba34
¹¹⁵ In	1976Al06,1972Ra39,1973Sc23	¹⁶² Dy	1989Sc31,1967Sc05,1986Bo43
¹¹⁵ Sn	1991Ra01	¹⁶³ Dy	1964Sc25
¹²¹ Sb	1972Sh02,1978Al09,1977Va11	¹⁶⁴ Dy	1965Sc09,1983Is04
¹²³ Sb	1973ShZZ,1980Al22	¹⁶⁵ Ho	1967Mo05,1984Ke15
¹²² Te	192000Bo24	¹⁶⁶ Er	1965Ko13,1970Mi01
¹²³ Te	1995Ge06,1983Ro13,1969Bu05	¹⁶⁷ Er	1991Da12,1991DaZT,1996Gi09
¹²⁴ Te	1999Ho01,1998Ho16,1997BoZW	¹⁶⁸ Er	1970Mu15
¹²⁸ Te	1981Ho12,1999Bo31	¹⁷⁰ Er	1971Al01,1984MuZY

Isotope	NSR Reference Keynumber(s)
¹⁶⁹ Tm	1994HoZZ,1989Du03,1968Lo09
¹⁶⁸ Yb	1969Bo16,1972Wi12,1973GrZV
¹⁷⁰ Yb	1972Wa10
¹⁷¹ Yb	1985Ge02,1975Gr32,1988Su01
¹⁷² Yb	1971Al01
¹⁷³ Yb	1987Ge01,1981Gr01
¹⁷⁴ Yb	1971Al27,1971Br17
¹⁷⁶ Yb	1972Al19,1973PrZI,1990Bo49
¹⁷⁵ Lu	1991Kl02
¹⁷⁶ Lu	1965Ma18,1975Ge11,1971Ma45
¹⁷⁴ Hf	1971Al01
¹⁷⁶ Hf	1967Pr08,1967Na07
¹⁷⁷ Hf	1986Ha22,1987Bo52
¹⁷⁸ Hf	1989Ri03,1976Be23
¹⁷⁹ Hf	1974Bu22,1990Bo52,1986RoZM
¹⁸⁰ Hf	1971Al22,1967Pr08
¹⁸⁰ Ta	1973LaZY
¹⁸¹ Ta	1979Va10,1971He13,1974An12
¹⁸² W	1997Pr02
¹⁸³ W	1974Gr11,1975Bu01
¹⁸⁴ W	1973PrYV
¹⁸⁶ W	1973PrZI,1969BoZN,1989BoYT
¹⁸⁵ Re	1969La11,1973Gl06
¹⁸⁷ Re	1972Sh13,1968Su01,1978Sc10
¹⁸⁴ Os	1974PrZY,1974Pr15
¹⁸⁶ Os	1974Pr15,1974NeZY
¹⁸⁷ Os	1983Fe06
¹⁸⁸ Os	1992Br17,1976Be50
¹⁸⁹ Os	1979Ca02
¹⁹⁰ Os	1991Bo35
¹⁹² Os	1978Be22,1979Wa04
¹⁹¹ Ir	1991Ke10
¹⁹³ Ir	1998Ba85,1998Ba42,1987CoZW
¹⁹⁴ Pt	1987Ca03,1982Wa20
¹⁹⁵ Pt	1979Ci04
¹⁹⁶ Pt	1978Ya07
¹⁹⁷ Au	1996Ma70,1996Ma75,1993Pe04
¹⁹⁹ Hg	1970Or05,1971Ma10,1974Br02
²⁰¹ Hg	1975Br02
²⁰³ Tl	1974Co21,1975RaYX
²⁰⁴ Pb	1967Ju02,1983Hu13
²⁰⁶ Pb	1983Hu13
²⁰⁷ Pb	1998Be19,1983Ma55
²⁰⁹ Bi	1989Sh20,1983Ts01
²³² Th	1974Ke13,1979Je01
²³⁴ U	1972Ri08,1979Al03
²³⁵ U	1975OtZX,1973Gr20,1970Ka22
²³⁸ U	1978Bo12,1972Bo46,1984Ch05

Complete Reference Citations

- 1963Gr18** L.V.Groshev, A.M.Demidov, V.A.Ivanov, V.N.Lutsenko, V.I.Pelevhov, Nucl. Phys. 43, 669 (1963)
- 1964Sc25** O.W.B.Schult, U.Gruber, B.P.Maier, F.W.Stanek, Z. Phys. 180, 298 (1964)
- 1965Ko13** H.R.Koch, Z. Phys. 187, 450 (1965)
- 1965Ma18** B.P.K.Maier, Z. Phys. 184, 153 (1965)
- 1965Sc09** O.W.B.Schult, B.P.Maier, U.Gruber, Z. Phys. 182, 171 (1965)
- 1966Sm03** R.K.Smither, Phys. Rev. 150, 964 (1966)
- 1967Ar14** S.E.Arnell, R.Hardell, A.Hasselgren, L.Jonsson, O.Skeppstedt, Nucl. Instrum. Meth. 54, 165 (1967)
- 1967Ba34** A.Backlin, A.Suarez, O.W.B.Schult, B.P.K.Maier, U.Gruber, E.B.Shera, D.W.Hafemeister, W.N.Shelton, R.K.Sheline, Phys. Rev. 160, 1011 (1967)
- 1967Ba79** G.A.Bartholomew, A.Doveika, K.M.Eastwood, S.Monaro, L.V.Groshev, A.M.Demidov, V.I.Pelevhov, L.L.Sokolovskii, Nuclear Data A3, 367 (1967)
- 1967Gr16** H.Gruppelaar, P.Spilling, Nucl. Phys. A102, 226 (1967)
- 1967Ju02** E.T.Jurney, H.T.Motz, S.H.Vegors, Jr., Nucl. Phys. A94, 351 (1967)
- 1967Mo05** H.T.Motz, E.T.Jurney, O.W.B.Schult, H.R.Koch, U.Gruber, B.P.Maier, H.Baader, G.L.Struble, J.Kern, R.K.Sheline, T.Von Egidy, T.Elze, E.Bieber, A.Backlin, Phys. Rev. 155, 1265 (1967)
- 1967Na07** A.I.Namenson, H.H.Bolotin, Phys. Rev. 158, 1206 (1967)
- 1967Pr08** P.T.Prokofev, M.K.Balodis, Y.Y.Berzin, V.A.Bondarenko, N.K.Kramer, E.Y.Lure, G.L.Rezvaya, L.I.Simonova, Atlas Spectra of Conversion Electron From Thermal Neutron Capture in Nuclei with $A = 143 - 197$ and Schemes of Radiative Transitions, 'Zinatne', Riga (1967)
- 1967Sc05** O.W.B.Schult, M.E.Bunker, D.W.Hafemeister, E.B.Shera, E.T.Jurney, J.W.Starner, A.Backlin, B.Fogelberg, U.Gruber, B.P.K.Maier, H.R.Koch, W.N.Shelton, M.Minor, R.K.Sheline, Phys. Rev. 154, 1146 (1967)
- 1968Gr11** H.Gruppelaar, P.Spilling, A.M.J.Spits, Nucl. Phys. A114, 463 (1968)
- 1968Gr32** L.V.Groshev, A.M.Demidov, V.I.Pelevhov, L.L.Sokolovskii, G.A.Bartholomew, A.Doveika, K.M.Eastwood, S.Monaro, Nucl. Data Tables A5, 1 (1968)
- 1968Ir02** J.-L.Irigaray, G.-Y.Petit, R.Samama, P.Carlos, J.Girard, G.Perrin, Compt. Rend. 267B, 1358 (1968)
- 1968Ju01** E.T.Jurney, H.T.Motz, R.K.Sheline, E.B.Shera, J.Vervier, Nucl. Phys. A111, 105 (1968)
- 1968Ke08** J.Kern, G.L.Struble, R.K.Sheline, E.T.Jurney, H.R.Koch, B.P.K.Maier, U.Gruber, O.W.B.Schult, Phys. Rev. 173, 1133 (1968)
- 1968Lo09** M.A.Lone, R.E.Chrien, O.A.Wasson, M.Beer, M.R.Bhat, H.R.Muether, Phys. Rev. 174, 1512 (1968)
- 1968Su01** A.A.Suarez, T.v.Egidy, W.Kaiser, H.F.Mahlein, A.Jones, Nucl. Phys. A107, 417 (1968)
- 1969ArZT** S.E.Arnell, R.Hardell, O.Skeppstedt, E.Wallander, Proc. Int. Symp. Neutron Capture Gamma-Ray Spectroscopy, Studsvik, Intern. At. En. Agency, Vienna, p. 231 (1969)
- 1969Bo16** V.Bondarenko, P.Prokofev, P.Manfrass, A.Andreeff, Latvijas PSR Zinatnu Akad. Vestis, Fiz. Teh. Zinatnu Ser., No. 1, 3 (1969)
- 1969BoZN** H.H.Bolotin, D.A.McClure, Proc. Intern. Symp. Neutron Capture Gamma-Ray Spectroscopy, Studsvik, Int. At. En. Agency, Vienna, p. 389 (1969)
- 1969Bu05** D.L.Bushnell, R.P.Chaturvedi, R.K.Smither, Phys. Rev. 179, 1113 (1969)
- 1969Da15** J.W.Dawson, R.K.Sheline, E.T.Jurney, Phys. Rev. 181, 1618 (1969)
- 1969Fa05** U.Fanger, W.Michaelis, H.Schmidt, H.Ottmar, Nucl. Phys. A128, 641 (1969)
- 1969Ge07** W.Gelletly, J.A.Moragues, M.A.J.Mariscotti, W.R.Kane, Phys. Rev. 181, 1682 (1969)
- 1969Gr08** H.Gruppelaar, A.M.F.Op Den Kamp, A.M.J.Spits, Nucl. Phys. A131, 180 (1969)
- 1969Gr31** L.V.Groshev, V.N.Dvoretzkii, A.M.Demidov, M.S.Alvash, Yadern. Fiz. 10, 681

- (1969); Soviet J. Nucl. Phys. 10, 392 (1970)
- 1969Ko05** J.Kopecky, E.Warming, Nucl. Phys. A127, 385 (1969)
- 1969La11** R.G.Lanier, R.K.Sheline, H.F.Mahlein, T.v.Egidy, W.Kaiser, H.R.Koch, U.Gruber, B.P.K.Maier, O.W.B.Schult, D.W.Hafemeister, E.B.Shera, Phys. Rev. 178, 1919 (1969)
- 1969Mo13** J.A.Moragues, M.A.J.Mariscotti, W.Gelletly, W.R.Kane, Phys. Rev. 180, 1105 (1969)
- 1969Ra10** N.C.Rasmussen, Y.Hukai, T.Inouye, V.J.Orphan, AFCRL-69-0071 (MITNE-85) (1969)
- 1969Re11** E.R.Reddingius, H.Postma, Nucl. Phys. A137, 389 (1969)
- 1969Sm04** R.K.Smither, E.Bieber, T.von Egidy, W.Kaiser, K.Wien, Phys. Rev. 187, 1632 (1969)
- 1970Ba21** I.F.Barchuk, D.A.Bazavov, G.V.Belykh, V.I.Golyshkin, A.V.Murzin, A.F.Ogorodnik, Yad. Fiz. 11, 934 (1970); Sov. J. Nucl. Phys. 11, 519 (1970)
- 1970Ba54** I.F.Barchuk, D.A.Bazavov, G.V.Belykh, V.I.Golyshkin, A.V.Murzin, A.F.Ogorodnik, Izv. Akad. Nauk SSSR, Ser. Fiz. 34, 1775 (1970); Bull. Acad. Sci. USSR, Phys. Ser. 34, 1579 (1971)
- 1970Bo29** L.M.Bollinger, G.E.Thomas, Phys. Rev. C2, 1951 (1970)
- 1970Cr04** F.P.Cranston, R.E.Birkett, D.H.White, J.A.Hughes, Nucl. Phys. A153, 413 (1970)
- 1970Fa06** U.Fanger, D.Heck, W.Michaelis, H.Ottmar, H.Schmidt, R.Gaeta, Nucl. Phys. A146, 549 (1970)
- 1970GaZQ** J.-J.Gardien, Thesis, Univ. Paris (1970); FRNC-TH-37 (1970)
- 1970Ge03** W.Gelletly, J.A.Moragues, M.A.J.Mariscotti, W.R.Kane, Phys. Rev. C1, 1052 (1970)
- 1970Ha56** R.Hardell, C.Beer, Phys. Scr. 1, 85 (1970)
- 1970He27** D.Heck, N.Ahmed, U.Fanger, W.Michaelis, H.Ottmar, H.Schmidt, Nucl. Phys. A159, 49 (1970)
- 1970Ju04** E.T.Jurney, R.K.Sheline, E.B.Shera, H.R.Koch, B.P.K.Maier, U.Gruber, H.Baader, D.Breitig, O.W.B.Schult, J.Kern, G.L.Struble, Phys. Rev. C2, 2323 (1970)
- 1970Ka22** W.R.Kane, Phys. Rev. Lett. 25, 953 (1970)
- 1970Li04** H.Linusson, R.Hardell, S.E.Arnell, Ark. Fys. 40, 197 (1970)
- 1970Mi01** W.Michaelis, F.Weller, U.Fanger, R.Gaeta, G.Markus, H.Ottmar, H.Schmidt, Nucl. Phys. A143, 225 (1970)
- 1970Mu15** T.J.Mulligan, R.K.Sheline, M.E.Bunker, E.T.Jurney, Phys. Rev. C2, 655 (1970)
- 1970Or05** V.J.Orphan, N.C.Rasmussen, T.L.Harper, GA-10248 (1970)
- 1971Al01** G.Alenius, S.E.Arnell, C.Schale, E.Wallander, Nucl. Phys. A161, 209 (1971)
- 1971Al22** G.Alenius, S.E.Arnell, C.Schale, E.Wallander, Phys. Scr. 3, 105 (1971)
- 1971Al27** G.Alenius, S.E.Arnell, C.Schale, E.Wallander, Phys. Scr. 4, 35 (1971)
- 1971Ar39** S.E.Arnell, R.Hardell, A.Hasselgren, C.-G.Mattsson, O.Skeppstedt, Phys. Scr. 4, 89 (1971)
- 1971Be41** M.J.Bennett, R.K.Sheline, Y.Shida, Nucl. Phys. A171, 113 (1971)
- 1971Br17** D.Breitig, Z. Naturforsch. 26a, 371 (1971)
- 1971Gr28** L.V.Groshev, L.I.Govor, A.M.Demidov, A.S.Rakhimov, Yad. Fiz. 13, 1129 (1971); Sov. J. Nucl. Phys. 13, 647 (1971)
- 1971Gr37** L.V.Groshev, A.M.Demidov, V.F.Leonov, L.L.Sokolovskii, Yad. Fiz. 14, 473 (1971); Sov. J. Nucl. Phys. 14, 265 (1972)
- 1971Gr42** L.V.Groshev, A.M.Demidov, L.L.Sokolovskii, Izv. Akad. Nauk SSSR, Ser. Fiz. 35, 1644 (1971); Bull. Acad. Sci. USSR, Phys. Ser. 35, 1497 (1972)
- 1971He10** D.Heck, U.Fanger, W.Michaelis, H.Ottmar, H.Schmidt, Nucl. Phys. A165, 327 (1971)
- 1971He13** R.G.Helmer, R.C.Greenwood, C.W.Reich, Nucl. Phys. A168, 449 (1971)
- 1971Kn06** R.Knerr, H.Vonach, Z. Phys. 246, 151 (1971)
- 1971Ma10** W.Mampe, T.von Egidy, W.Kaiser, K.Schreckenbach, Z. Naturforsch. 26a, 405 (1971)
- 1971Ma45** P.Manfrass, H.Prade, M.R.Beitins, W.A.Bondarenko, N.D.Kramer, P.T.Prokofev, Nucl. Phys. A172, 298 (1971)
- 1971Ot01** H.Ottmar, N.M.Ahmed, U.Fanger, D.Heck, W.Michaelis, H.Schmidt, Nucl. Phys. A164, 69 (1971)

- 1971Ra07** D.Rabenstein, H.Vonach, Z. Naturforsch. 26a, 458 (1971)
- 1971Te01** J.Tenenbaum, R.Moreh, Y.Wand, G.Ben-David, Phys. Rev. C3, 663 (1971)
- 1971Ve03** J.Vervier, H.H.Bolotin, Phys. Rev. C3, 1570 (1971)
- 1972Al19** G.Alenius, S.E.Arnell, C.Schale, E.Wallander, Nucl. Phys. A186, 209 (1972)
- 1972Bo46** L.M.Bollinger, G.E.Thomas, Phys. Rev. C6, 1322 (1972)
- 1972Bo75** A.P.Bogdanov, A.V.Soroka, Vestsi Akad. Navuk BSSR, Ser. Fiz. -Mat. Navuk No. 6, 96 (1972)
- 1972FaZW** U.Fanger, D.Heck, R.Pepelnik, H.Schmidt, J.Wood, Contrib. Conf. Nuclear Structure Study with Neutrons, Budapest, p. 72 (1972)
- 1972Gr34** L.V.Groshev, L.I.Govor, A.M.Demidov, Izv. Akad. Nauk SSSR, Ser. Fiz. 36, 833 (1972); Bull. Acad. Sci. USSR, Phys. Ser. 36, 753 (1973)
- 1972Ha74** A.Hasselgren, Nucl. Phys. A198, 353 (1972)
- 1972Kn07** U.A.Knatsko, S.A.Nyagrei, E.A.Rudak, A.M.Khilmanovich, Vestsi Akad. Navuk BSSR, Ser. Fiz. -Mat. Navuk No. 3, 79 (1972)
- 1972Ko15** J.Kopecky, K.Abrahams, F.Stecher-Rasmussen, Nucl. Phys. A188, 535 (1972)
- 1972Lo26** G.D.Loper, G.E.Thomas, Nucl. Instrum. Meth. 105, 453 (1972)
- 1972Ma42** C.G.Mattsson, S.E.Arnell, L.Jonsson, Phys. Scr. 5, 58 (1972)
- 1972Ra39** D.Rabenstein, D.Harrach, H.Vonach, G.G.Dussel, R.P.I.Perazzo, Nucl. Phys. A197, 129 (1972)
- 1972Ri08** F.A.Rickey, E.T.Jurney, H.C.Britt, Phys. Rev. C5, 2072 (1972)
- 1972Sh02** E.B.Shera, Priv. Comm. (February 1972)
- 1972Sh13** E.B.Shera, U.Gruber, B.P.K.Maier, H.R.Koch, O.W.B.Schult, R.G.Lanier,, Phys. Rev. C6, 537 (1972)
- 1972St06** F.Stecher-Rasmussen, J.Kopecky, K.Abrahams, W.Ratynski, Nucl. Phys. A181, 250 (1972)
- 1972Wa10** E.Wallander, E.Selin, Nucl. Phys. A188, 129 (1972)
- 1972We10** R.Weishaupt, D.Rabenstein, Z. Phys. 251, 105 (1972)
- 1972Wh02** D.H.White, R.E.Birkett, Phys. Rev. C5, 513 (1972)
- 1972Wh05** D.H.White, R.E.Howe, Nucl. Phys. A187, 12 (1972)
- 1972Wi12** L.Wimmer, Priv. Comm. (May 1972)
- 1973Ba57** I.F.Barchuk, G.V.Belykh, V.I.Golyshkin, A.V.Murzin, A.F.Ogorodnik, Izv. Akad. Nauk SSSR, Ser. Fiz. 37, 1080 (1973); Bull. Acad. Sci. USSR, Phys. Ser. 37, No. 5, 146 (1974)
- 1973De39** A.M.Demidov, M.R.Akhmed, M.A.Khalil, S.Al-Nazar, Izv. Akad. Nauk SSSR, Ser. Fiz. 37, 998 (1973); Bull. Acad. Sci. USSR, Phys. Ser. 37, No. 5, 74 (1974)
- 1973Gl06** J.Glatz, Z. Phys. 265, 335 (1973)
- 1973Gr20** R.G.Graves, R.E.Chrien, D.I.Garber, G.W.Cole, O.A.Wasson, Phys. Rev. C8, 781 (1973)
- 1973GrZV** R.C.Greenwood, Priv. Comm. (1973)
- 1973HaWJ** D.Harrach, Proc. Int. Conf. Nuc. Phys., Munich, J. de Boer, H. J. Mang, Eds. , North-Holland Publ. Co., Amsterdam, Vol. 1, p. 175 (1973)
- 1973Ko27** J.Kopecky, K.Abrahams, F.Stecher-Rasmussen, Nucl. Phys. A215, 45 (1973)
- 1973LaZY** J.T.Larsen, R.G.Lanier, Priv. Comm. (March 1973)
- 1973PrYV** H.Prade, W.Andrejscheff, P.Manfrass, M.Mohsen, W.Seidel, M.R.Beitins, L.I.Simonova, ZfK-260 (1973)
- 1973PrZI** P.Prokofev, M.Balodis, M.Beitins, Y.Berzin, V.Bondarenko, N.Kramer, A.Krumina, G.Rezvaya, L.Simonova, Spectra of Electromagnetic Transitions and Level Schemes Following Thermal Neutron Capture by Nuclides with A

- 143-193, P. Prokofev, J. Berzins, G. Rezvaya, Eds., Publishing House 'Zinatne', Riga (1973)
- 1973Sc23** K.Schreckenbach, A.A.Suarez, T.von Egidy, Z. Naturforsch. 28a, 1308 (1973)
- 1973ShZZ** E.B.Shera, Priv. Comm. (Jan. 1973)
- 1973Sp06** A.M.J.Spits, J.A.Akkermans, Nucl. Phys. A215, 260 (1973)
- 1974An12** W.Andrejscheff, P.Manfrass, W.Seidel, Nucl. Phys. A226, 142 (1974)
- 1974Bo19** H.Borner, O.W.B.Schult, Z. Naturforsch. 29a, 385 (1974)
- 1974Br02** D.Breitig, R.F.Casten, G.W.Cole, Phys. Rev. C9, 366 (1974); Erratum Phys. Rev. C9, 2088 (1974)
- 1974Bu22** D.L.Bushnell, D.J.Buss, R.K.Smither, Phys. Rev. C10, 2483 (1974)
- 1974Co21** A.H.Colenbrander, T.J.Kennett, Can. J. Phys. 52, 1215 (1974)
- 1974Gr11** R.C.Greenwood, C.W.Reich, Nucl. Phys. A223, 66 (1974)
- 1974Hr01** B.Hrastnik, H.Seyfarth, A.M.Hassan, W.Delang, P.Gottel, Nucl. Phys. A219, 381 (1974)
- 1974JuZW** E.T.Jurney, USNDC-11, p. 149 (1974)
- 1974Ke01** J.Kern, G.Mauron, B.Michaud, K.Schreckenbach, T.Von Egidy, W.Mampe, H.R.Koch, H.A.Baader, D.Breitig, U.Gruber, B.P.K.Maier, O.W.B.Schult, J.T.Larsen,, Nucl. Phys. A221, 333 (1974)
- 1974Ke13** J.Kern, D.Duc, Phys. Rev. C10, 1554 (1974)
- 1974KoYY** J.Kopecky, Contrib. Int. Symp. Neutron Capture Gamma Ray Spectrosc. and Related Topics, 2nd, Petten, p. 325 (1974)
- 1974NeZY** L.A.Neiburg, L.I.Simonova, Program and Theses, Proc. 24th Ann. Conf. Nucl. Spectrosc. Struct. At. Nuclei, Kharkov, p. 151 (1974)
- 1974Pr15** P.T.Prokofev, L.I.Simonova, Izv. Akad. Nauk SSSR, Ser. Fiz. 38, 2135 (1974); Bull. Acad. Sci. USSR, Phys. Ser. 38, No. 10, 104 (1974)
- 1974PrZY** P.T.Prokofev, L.A.Neiburg, L.I.Simonova, Program and Theses, Proc. 24th Ann. Conf. Nucl. Spectrosc. Struct. At. Nuclei, Kharkov, p. 149 (1974)
- 1975Br02** D.Breitig, R.F.Casten, W.R.Kane, G.W.Cole, J.A.Cizewski, Phys. Rev. C11, 546 (1975)
- 1975Bu01** D.L.Bushnell, J.Hawkins, R.Goebbert, R.K.Smither, Phys. Rev. C11, 1401 (1975)
- 1975Co05** A.H.Colenbrander, T.J.Kennett, Can. J. Phys. 53, 236 (1975)
- 1975DeYM** J.de Boer, Proc. Int. Symp. Neutron Capture Gamma-Ray Spectroscopy and Related Topics, 2nd, Petten, p. 609 (1975)
- 1975Ge11** D.Geinoz, J.Kern, R.Piepenbring, Nucl. Phys. A251, 305 (1975)
- 1975Gr32** R.C.Greenwood, C.W.Reich, S.H.Vegors,Jr., Nucl. Phys. A252, 260 (1975)
- 1975Hi03** D.L.Hillis, C.R.Bingham, D.A.McClure, N.S.Kendrick, Jr., J.C.Hill, S.Raman, J.B.Ball, J.A.Harvey, Phys. Rev. C12, 260 (1975)
- 1975OtZX** H.Ottmar, P.Matussek, I.Piper, Proc. Int. Symp. Neutron Capture Gamma Ray Spectroscopy and Related Topics, 2nd, Petten, The Netherlands (1974), K. Abrahams, F. Stecher-Rasmussen, P. Van Assche, Eds., Reactor Centrum Nederland, p. 658 (1975)
- 1975Ra07** D.Rabenstein, D.Harrach, Nucl. Phys. A242, 189 (1975)
- 1975RaYX** D.Rabenstein, Proc. Int. Symp. Neutron Capture Gamma-Ray Spectrosc. and Related Topics, 2nd, Petten, p. 584 (1974)
- 1975Ro16** R.Roussille, J.A.Pinston, H.Borner, H.R.Koch, D.Heck, Nucl. Phys. A246, 380 (1975)
- 1975SmZT** H.A.Smith Jr., M.E.Bunker, J.W.Starner, Priv. Comm. (October 1975)
- 1975Wi06** W.M.Wilson, G.E.Thomas, H.E.Jackson, Phys. Rev. C11, 1477 (1975)
- 1976Al06** V.L.Alexeev, B.A.Emelianov, D.M.Kaminker, Y.L.Khazov, I.A.Kondurov,

- Y.E.Loginov, V.L.Rumiantsev, S.L.Sakharov, A.I.Smirnov, Nucl. Phys. A262, 19 (1976)
- 1976BaYM** I.F.Barchuk, G.V.Belykh, V.I.Golyshkin, A.F.Ogorodnik, M.M.Tuchinsky, Program and Theses, Proc. 26th Ann. Conf. Nucl. Spectrosc. Struct. At. Nuclei, Baku, p. 67 (1976)
- 1976Be23** M.R.Beitins, N.D.Kramer, P.T.Prokofjev, J.J.Tamberg, L.Jacobs, G.Vandenput, J.M.van den Cruyce, P.H.M.van Assche, D.Breitig, H.A.Baader, H.R.Koch, Nucl. Phys. A262, 273 (1976)
- 1976Be50** D.Benson, Jr., P.Kleinheinz, R.K.Sheline, E.B.Shera, Phys. Rev. C14, 2095 (1976)
- 1976Bu14** D.L.Bushnell, G.R.Tassotto, R.K.Smither, Phys. Rev. C14, 75 (1976)
- 1976Ge02** W.Gelletly, W.R.Kane, R.F.Casten, Phys. Rev. C13, 1434 (1976)
- 1976Mi19** J.A.Mirza, A.M.Khan, M.Irshad, H.A.Schmidt, A.F.M.Ishaq, M.Anwar-Ul-Islam, Nucl. Phys. A272, 133 (1976)
- 1976Pi04** J.A.Pinston, R.Roussille, H.Borner, H.R.Koch, Nucl. Phys. A264, 1 (1976)
- 1976Pi13** J.A.Pinston, R.Roussille, H.Borner, W.F.Davidson, P.Jeuch, H.R.Koch, K.Schreckenbach, D.Heck, Nucl. Phys. A270, 61 (1976)
- 1976Ro03** R.Roussille, J.A.Pinston, F.Braumann, P.Jeuch, J.Larysz, W.Mampe, K.Schreckenbach, Nucl. Phys. A258, 257 (1976)
- 1977Ba33** I.F.Barchuk, G.V.Belykh, V.I.Golyshkin, A.F.Ogorodnik, M.M.Tuchinskii, Izv. Akad. Nauk SSSR, Ser. Fiz. 41, 101 (1977); Bull. Acad. Sci. USSR, Phys. Ser. 41, No. 1, 82 (1977)
- 1977Be03** M.J.Bennett, R.K.Sheline, Phys. Rev. C15, 146 (1977)
- 1977DoZP** H.-P.Do, Thesis, Univ. Claude Bernard, Lyon (1977); LYCEN-7736 (1977)
- 1977Is01** A.F.M.Ishaq, A.Robertson, W.V.Prestwich, T.J.Kennett, Z. Phys. A281, 365 (1977)
- 1977Je03** C.M.Jensen, R.G.Lanier, G.L.Struble, L.G.Mann, S.G.Prussin, Phys. Rev. C15, 1972 (1977)
- 1977Mc05** A.B.McDonald, E.D.Earle, M.A.Lone, F.C.Khanna, H.C.Lee, Nucl. Phys. A281, 325 (1977)
- 1977Pr07** S.G.Prussin, R.G.Lanier, G.L.Struble, L.G.Mann, S.M.Schoenung, Phys. Rev. C16, 1001 (1977)
- 1977RuZR** E.A.Rudak, A.V.Soroka, V.N.Tadeush, Program and Theses, Proc. 27th Ann. Conf. Nucl. Spectrosc. Struct. At. Nuclei, Tashkent, p. 60 (1977)
- 1977Va11** W.F.van Gunsteren, D.Rabenstein, Z. Phys. A282, 55 (1977)
- 1978Al09** V.L.Alexeev, B.A.Emelianov, A.I.Egorov, L.P.Kabina, D.M.Kaminker, Y.L.Khazov, I.A.Kondurov, E.K.Leushkin, Y.E.Loginov, V.V.Martynov, V.L.Rumiantsev, S.L.Sakharov, P.A.Sushkov, H.G.Borner, W.F.Davidson, J.A.Pinston, K.Schreckenbach, Nucl. Phys. A297, 373 (1978)
- 1978Be22** D.Benson, Jr., P.Kleinheinz, R.K.Sheline, E.B.Shera, Z. Phys. A285, 405 (1978)
- 1978Bo12** H.G.Borner, H.R.Koch, H.Seyfarth, T.von Egidy, W.Mampe, J.A.Pinston, K.Schreckenbach, D.Heck, Z. Phys. A286, 31 (1978)
- 1978Do06** Do Huu Phuoc, R.Chery, H.G.Borner, W.F.Davidson, J.A.Pinston, R.Roussille, K.Schreckenbach, H.R.Koch, H.Seyfarth, D.Heck, Z. Phys. A286, 107 (1978)
- 1978Gr14** R.C.Greenwood, C.W.Reich, H.A.Baader, H.R.Koch, D.Breitig, O.W.B.Schult, B.Fogelberg, A.Backlin, W.Mampe, T.von Egidy, E.Schreckenbach, Nucl. Phys. A304, 327 (1978)
- 1978Gu14** H.H.Guven, B.Kardon, H.Seyfarth, Z. Phys. A287, 271 (1978)
- 1978LoZT** CONF BNL (Neutron Capt γ -Ray Spectr), Contrib, No48, Lone
- 1978LoZW** CONF Brookhaven (Neutron Capt γ -Ray Spectr), Proc, P678, Lone
- 1978LoZX** M.A.Lone, G.A.Bartholomew, Proc. Intern. Symp. Neutron Capture Gamma Ray

- Spectroscopy and Related Topics, 3rd, BNL, Upton (1978), R. E. Chrien, W. R. Kane, eds., Plenum Press, New York, p. 675 (1978)
- 1978PrZY** P.T.Prokofjev, M.Balodis, N.Kramer, L.Lokshina, L.Simonova, K.Schreckenbach, W.Davidson, J.Pinston, D.Warner, P.Van Assche, LAFI-006 (1978)
- 1978Ro03** A.Robertson, T.J.Kennett, W.V.Prestwich, Z. Phys. A284, 407 (1978)
- 1978Sc10** K.D.Schilling, L.Kaubler, W.Andrejscheff, T.M.Muminov, V.G.Kalinnikov, N.Z.Marupov, F.R.May, W.Seidel, Nucl. Phys. A299, 189 (1978)
- 1978Ve06** R.Vennink, W.Ratynski, J.Kopecky, Nucl. Phys. A299, 429 (1978)
- 1978Vo05** T.von Egidy, W.Kaiser, W.Mampe, C.Hillenbrand, W.Stoffl, R.G.Lanier, K.Muhlbauer, O.W.B.Schult, H.R.Koch, H.A.Baader, R.L.Mlekodaj, R.K.Sheline, E.B.Shera, J.Ungrin, P.T.Prokofjev, L.I.Simonova, M.K.Balodis, H.Seyfarth, B.Kardon,, Z. Phys. A286, 341 (1978)
- 1978WaZM** D.D.Warner, W.F.Davidson, W.Gelletly, Contrib. Int. Symp. Neutron Capture Gamma-Ray Spectrosc. and Related Topics, 3rd, Upton, N. Y., No. 84 (1978)
- 1978Ya07** Y.Yamazaki, R.K.Sheline, E.B.Shera, Phys. Rev. C17, 2061 (1978); Erratum Phys. Rev. C18, 2450 (1978)
- 1979Al03** J.Almeida, T.von Egidy, P.H.M.van Assche, H.G.Borner, W.F.Davidson, K.Schreckenbach, A.I.Namenson, Nucl. Phys. A315, 71 (1979)
- 1979Bo41** M.Bogdanovic, S.Koicki, J.Simic, B.Lalovic, D.Breitig, R.Koch, H.A.Baader, O.V.B.Schult, W.R.Kane, R.F.Casten, Fizika (Zagreb) 11, 157 (1979)
- 1979Br25** F.Braumann, K.Schreckenbach, T.von Egidy, Nucl. Instrum. Meth. 166, 243 (1979)
- 1979BrZE** P.M.Brewster, Thesis, McMaster Univ. (1979)
- 1979Ca02** R.F.Casten, M.R.Macphail, W.R.Kane, D.Breitig, K.Schreckenbach, J.A.Cizewski, Nucl. Phys. A316, 61 (1979)
- 1979Ci04** J.A.Cizewski, R.F.Casten, G.J.Smith, M.R.Macphail, M.L.Stelts, W.R.Kane, H.G.Borner, W.F.Davidson, Nucl. Phys. A323, 349 (1979)
- 1979HeZT** D.Heck, Priv. Comm. (December 1979)
- 1979Je01** P.Jeuch, T.von Egidy, K.Schreckenbach, W.Mampe, H.G.Borner, W.F.Davidson, J.A.Pinston, R.Roussille, R.C.Greenwood, R.E.Chrien, Nucl. Phys. A317, 363 (1979)
- 1979Pi08** J.A.Pinston, W.Mampe, R.Roussille, K.Schreckenbach, D.Heck, H.G.Borner, H.R.Koch, S.Andre, D.Barneoud, Nucl. Phys. A321, 25 (1979)
- 1979SeZT** H.Seyfarth, H.H.Guven, B.Viardon, Priv. Comm. (1979)
- 1979Va10** J.M.Van den Cruyce, G.Vandenput, L.Jacobs, P.H.M.Van Assche, H.A.Baader, D.Breitig, H.R.Koch, J.K.Alksnis, J.J.Tamberg, M.K.Balodis, P.T.Prokofjev, W.Delang, P.Gottel, H.Seyfarth, Phys. Rev. C20, 504 (1979)
- 1979Wa04** D.D.Warner, W.F.Davidson, H.G.Borner, R.F.Casten, A.I.Namenson, Nucl. Phys. A316, 13 (1979)
- 1980Al22** V.L.Alexeev, I.A.Kondurov, Yu. E. Loginov, V.V.Martynov, S.L.Sakharov, H.G.Borner, W.F.Davidson, J.A.Pinston, K.Schreckenbach, Nucl. Phys. A345, 93 (1980)
- 1980Al31** V.P.Alfimenkov, S.B.Borzakov, E.V.Vasilyeva, Wo Wang Thuang, B.P.Osipenko, L.B.Pikelner, V.G.Tishin, E.I.Sharapov, Yad. Fiz. 32, 1491 (1980)
- 1980Ca02** R.F.Casten, G.J.Smith, M.R.Macphail, D.Breitig, W.R.Kane, M.L.Stelts, Phys. Rev. C21, 65 (1980)
- 1980De20** P.P.J.Delheij, K.Abrahams, W.J.Huiskamp, H.Postma, Nucl. Phys. A341, 45 (1980)
- 1980Ho29** J.Honzatko, K.Konecny, F.Becvar, E.A.Eissa, Czech. J. Phys. 30, 763 (1980)
- 1980Is02** M.A.Islam, T.J.Kennett, S.A.Kerr, W.V.Prestwich, Can. J. Phys. 58, 168 (1980)
- 1980Ko01** J.Kopecky, R.E.Chrien, H.I.Liou, Nucl. Phys. A334, 35 (1980)
- 1980Ve05** R.Vennink, J.Kopecky, P.M.Endt, P.W.M.Glaudemans, Nucl. Phys. A344, 421 (1980)
- 1981En07** G.Engler, R.E.Chrien, H.I.Liou, Nucl. Phys. A372, 125 (1981)
- 1981Gr01** R.C.Greenwood, C.W.Reich, Phys. Rev. C23, 153 (1981)

- 1981Ho12** J.Honzatko, K.Konecny, F.Becvar, E.A.Eissa, M.Kralik, Z. Phys. A299, 183 (1981)
- 1981Ke03** T.J.Kennett, W.V.Prestwich, M.A.Islam, Z. Phys. A299, 323 (1981)
- 1981Ke11** T.J.Kennett, W.V.Prestwich, M.A.Islam, Can. J. Phys. 59, 1212 (1981)
- 1981KoZW** B.K.Koene, R.E.Chrien, M.L.Stelts, L.K.Peker, Priv. Comm. (October 1981)
- 1982Ba15** I.F.Barchuk, V.I.Golyshkin, E.N.Gorban, Izv. Akad. Nauk SSSR, Ser. Fiz. 46, 63 (1982)
- 1982Ba28** A.Backlin, G.Hedin, B.Fogelberg, M.Saraceno, R.C.Greenwood, C.W.Reich, H.R.Koch, H.A.Baader, H.D.Breitig, O.W.B.Schult, K.Schreckenbach, T.Von Egidy, Nucl. Phys. A380, 189 (1982)
- 1982Ba69** I.F.Barchuk, V.I.Golyshkin, E.N.Gorban, Izv. Akad. Nauk SSSR, Ser. Fiz. 46, 2077 (1982)
- 1982Ju01** E.T.Jurney, P.J.Bendt, J.C.Browne, Phys. Rev. C25, 2810 (1982)
- 1982Kr12** B.Krusche, K.P.Lieb, H.Daniel, T.von Egidy, G.Bureau, H.G.Borner, R.Brissot, C.Hofmeyer, R.Rascher, Nucl. Phys. A386, 245 (1982)
- 1982Mu14** S.F.Mughabghab, M.A.Lone, B.C.Robertson, Phys. Rev. C26, 2698 (1982)
- 1982Sc03** K.Schreckenbach, A.I.Namenson, W.F.Davidson, T.Von Egidy, H.G.Borner, Nucl. Phys. A376, 149 (1982)
- 1982Sc14** H.H.Schmidt, P.Hungerford, H.Daniel, T.von Egidy, S.A.Kerr, R.Brissot, G.Barreau, H.G.Borner, C.Hofmeyr, K.P.Lieb, Phys. Rev. C25, 2888 (1982)
- 1982Ti02** T.A.A.Tielens, J.Kopecky, F.Stecher-Rasmussen, W.Ratynski, K.Abrahams, P.M.Endt, Nucl. Phys. A376, 421 (1982)
- 1982ToZS** Y.Tokunaga, H.G.Borner, JUL-Spez-145 (1982); Erratum (March 1983)
- 1982Va13** C.Van Der Leun, C.Alderliesten, Nucl. Phys. A380, 261 (1982)
- 1982Wa20** D.D.Warner, R.F.Casten, M.L.Stelts, H.G.Borner, G.Barreau, Phys. Rev. C26, 1921 (1982)
- 1983BrZK** A.M.Bruce, W.Gelletly, R.F.Casten, D.D.Warner, G.Colvin, K.Schreckenbach, M.Snelling, B.Moore, S.Kerr, W.F.Davidson, Univ. Manchester, Ann. Rept. , p. 77 (1983)
- 1983De28** M.G.Delfini, J.Kopecky, J.B.M.De Haas, H.I.Liou, R.E.Chrien, P.M.Endt, Nucl. Phys. A404, 225 (1983); Erratum Nucl. Phys. A410, 513 (1983)
- 1983De29** M.G.Delfini, J.Kopecky, R.E.Chrien, H.I.Liou, P.M.Endt, Nucl. Phys. A404, 250 (1983)
- 1983Fe06** P.Fettweis, J.C.Dehaes, Z. Phys. A314, 159 (1983)
- 1983Hu11** P.Hungerford, T.von Egidy, H.H.Schmidt, S.A.Kerr, H.G.Borner, E.Monmand, Z. Phys. A313, 325 (1983)
- 1983Hu13** P.Hungerford, T.von Egidy, H.H.Schmidt, S.A.Kerr, H.G.Borner, E.Monmand, Z. Phys. A313, 349 (1983)
- 1983Ii02** H.Iimura, T.Seo, S.Yamada, S.-I.Uehara, T.Hayashi, Ann. Rep. Res. Reactor Inst., Kyoto Univ. 16, 128 (1983)
- 1983Is04** M.A.Islam, W.V.Prestwich, T.J.Kennett, Phys. Rev. C27, 2401 (1983)
- 1983Ke11** T.J.Kennett, W.V.Prestwich, R.J.Tervo, J.S.Tsai, Nucl. Instrum. Methods 215, 159 (1983)
- 1983Ma55** M.A.J.Mariscotti, D.R.Bes, S.L.Reich, H.M.Sofia, P.Hungerford, S.A.Kerr, K.Schreckenbach, D.D.Warner, W.F.Davidson, W.Gelletly, Nucl. Phys. A407, 98 (1983)
- 1983Ro13** S.J.Robinson, W.D.Hamilton, D.M.Snelling, J. Phys. (London) G9, 961 (1983)
- 1983Ru08** J.F.A.G.Ruyl, P.M.Endt, Nucl. Phys. A407, 60 (1983)
- 1983Sn01** D.M.Snelling, W.D.Hamilton, J. Phys. (London) G9, 111 (1983)
- 1983Sn04** D.M.Snelling, W.D.Hamilton, J. Phys. (London) G9, 763 (1983)
- 1983Ts01** J.S.Tsai, T.J.Kennett, W.V.Prestwich, Phys. Rev. C27, 2397 (1983)

- 1983VeZZ** R.Vennink, Priv. Comm. (July 1983)
- 1984Ch05** R.E.Chrien, J.Kopecky, Nucl. Phys. A414, 281 (1984)
- 1984Ke15** T.J.Kennett, M.A.Islam, W.V.Prestwich, Phys. Rev. C30, 1840 (1984)
- 1984Ko29** J.Kopecky, M.G.Delfini, R.E.Chrien, Nucl. Phys. A427, 413 (1984)
- 1984Kr05** B.Krusche, K.P.Lieb, L.Ziegeler, H.Daniel, T.Von Egidy, R.Rascher, G.Barreau, H.G.Borner, D.D.Warner, Nucl. Phys. A417, 231 (1984)
- 1984Mh01** A.Mheemeed, K.Schreckenbach, G.Barreau, H.R.Faust, H.G.Borner, R.Brissot, P.Hungerford, H.H.Schmidt, H.J.Scheerer, T.Von Egidy, K.Heyde, J.L.Wood, P.Van Isacker, M.Waroquier, G.Wenes, M.L.Stelts, Nucl. Phys. A412, 113 (1984)
- 1984MuZY** S.F.Mughabghab, Neutron Cross Sections, Vol. 1, Neutron Resonance Parameters and Thermal Cross Sections, Part B, Z=61-100, Academic Press, New York (1984)
- 1984Ra09** S.Raman, W.Ratynski, E.T.Jurney, M.E.Bunker, J.W.Starner, Phys. Rev. C30, 26 (1984)
- 1984Ro06** H.Rotter, C.Heiser, K.D.Schilling, W.Andrejtscheff, L.K.Kostov, M.K.Balodis, Nucl. Phys. A417, 1 (1984)
- 1984Ru06** J.F.A.G.Ruyl, J.B.M.De Haas, P.M.Endt, L.Zybert, Nucl. Phys. A419, 439 (1984)
- 1984To11** Y.Tokunaga, H.Seyfarth, O.W.B.Schult, S.Brant, V.Paar, D.Vretenar, H.G.Borner, G.Barreau, H.Faust, Ch.Hofmeyr, K.Schreckenbach, R.A.Meyer, Nucl. Phys. A430, 269 (1984)
- 1984Vo01** T.von Egidy, H.Daniel, P.Hungerford, H.H.Schmidt, K.P.Lieb, B.Krusche, S.A.Kerr, G.Barreau, H.G.Borner, R.Brissot, C.Hofmeyr, R.Rascher, J. Phys. (London) G10, 221 (1984)
- 1985AIZN** V.L.Alekseev, A.I.Egorov, L.P.Kabina, I.A.Kondurov, E.K.Leushkin, Yu.E.Loginov, V.V.Martynov, V.L.Rumyantsev, S.L.Sakharov, P.A.Sushkov, Yu.L.Khazov, Program and Theses, Proc. 35th Ann. Conf. Nucl. Spectrosc. Struct. At. Nuclei, Leningrad, p. 85 (1985)
- 1985Bo48** M.Bogdanovic, H.Seyfarth, O.W.B.Schult, H.R.Borner, S.Kerr, F.Hoyler,, Fizika(Zagreb) 17, 219 (1985)
- 1985BuZU** M.E.Bunker, H.A.Smith,Jr., J.W.Starner, D.G.Burke, Priv. Comm. (February 1985)
- 1985Ge02** W.Gelletly, J.R.Larysz, H.G.Borner, R.F.Casten, W.F.Davidson, W.Mampe, K.Schreckenbach, D.D.Warner, J. Phys. (London) G11, 1055 (1985)
- 1985HoZQ** C.Hofmeyr, C.Franklyn, G.Barreau, H.Borner, R.Brissot, H.Faust, K.Schreckenbach, Priv. Comm. (1985)
- 1985Ke04** E.G.Kessler,Jr., G.L.Greene, R.D.Deslattes, H.G.Borner, Phys. Rev. C32, 374 (1985)
- 1985Ke11** T.J.Kennett, W.V.Prestwich, J.S.Tsai, Phys. Rev. C32, 2148 (1985)
- 1985Ko47** P.J.J.Kok, K.Abrahams, H.Postma, W.J.Huiskamp, Nucl. Instrum. Methods Phys. Res., B12, 325 (1985)
- 1985Kr06** B.Krusche, Ch.Winter, K.P.Lieb, P.Hungerford, H.H.Schmidt, T.Von Egidy, H.J.Scheerer, S.A.Kerr, H.G.Borner, Nucl. Phys. A439, 219 (1985)
- 1985Ma54** T.D.MacMahon, G.R.Massoumi, T.Mitsunari, M.Thein, O.Chalhoub, D.Breitig, H.A.Baader, U.Heim, H.R.Koch, L.Wimmer, H.Seyfarth, K.Schreckenbach, G.B.Orr, G.J.Smith, W.R.Kane, I.A.Kondurov, P.A.Sushkov, Yu.E.Loginov, D.Rabenstein, M.Bogdanovic, J. Phys. (London) G11, 1231 (1985)
- 1985Ra15** S.Raman, R.F.Carlton, J.C.Wells, E.T.Jurney, J.E.Lynn, Phys. Rev. C32, 18 (1985)
- 1985To10** Y.Tokunaga, H.Seyfarth, R.A.Meyer, O.W.B.Schult, H.G.Borner, G.Barreau, H.R.Faust, K.Schreckenbach, S.Brant, V.Paar, M.Vouk, D.Vretenar, Nucl. Phys. A439, 427 (1985)
- 1986Bo43** S.T.Boneva, E.V.Vasileva, Yu.P.Popov, A.M.Sukhovi, V.A.Khitrov, Yu.S.Yazvitsky, Izv. Akad. Nauk SSSR, Ser. Fiz. 50, 1831 (1986); Bull.

- Acad. Sci. USSR, Phys. Ser. 550, No. 9, 162 (1986)
- 1986GrZR** R.C.Greenwood, Priv. Comm. (1986)
- 1986Ha22** A.M.I.Haque, R.F.Casten, I.Forster, A.Gelberg, R.Rascher, R.Richter, P.von Brentano, G.Barreau, H.G.Borner, S.A.Kerr, K.Schreckenbach, D.D.Warner, Nucl. Phys. A455, 231 (1986)
- 1986Ko19** P.J.J.Kok, J.B.M.de Haas, K.Abrahams, H.Postma, W.J.Huiskamp, Z. Phys. A324, 271 (1986)
- 1986Pr05** W.V.Prestwich, T.J.Kennett, J.-S.Tsai, Z. Phys. A325, 321 (1986)
- 1986RoZM** A.A.Rodionov, S.L.Sakharov, Yu.L.Khazov, Program and Theses, Proc. 36th Ann. Conf. Nucl. Spectrosc. Struct. At. Nuclei, Kharkov, p. 129 (1986)
- 1986Sc25** H.H.Schmidt, W.Stoffl, T.von Egidy, P.Hungerford, H.J.Scheerer, K.Schreckenbach, H.G.Borner, D.D.Warner, R.E.Chrien, R.C.Greenwood, C.W.Reich, J. Phys. (London) G12, 411 (1986)
- 1986Va08** G.Vandenput, P.H.M.Van Assche, L.Jacobs, J.M.Van den Cruyce, R.K.Smithier, K.Schreckenbach, T.von Egidy, D.Breitig, H.A.Baader, H.R.Koch, Phys. Rev. C33, 1144 (1986)
- 1986Wi16** Ch.Winter, B.Krusche, K.P.Lieb, H.H.Schmidt, T.Von Egidy, P.Hungerford, F.Hoyler, H.G.Borner, Nucl. Phys. A460, 501 (1986)
- 1987Ba52** M.K.Balodis, P.T.Prokofjev, N.D.Kramer, L.I.Simonova, K.Schreckenbach, W.F.Davidson, J.A.Pinston, P.Hungerford, H.H.Schmidt, H.J.Scheerer, T.von Egidy, P.H.M.van Assche, A.M.J.Spits, R.F.Casten, W.R.Kane, D.D.Warner, J.Kern, Nucl. Phys. A472, 445 (1987)
- 1987BaYW** K.A.Baskova, A.B.Vovk, T.M.Gerus, L.I.Gorov, A.M.Demidov, V.A.Kurkin, IAE-4544/2 (1987)
- 1987Bo24** M.Bogdanovic, R.Brissot, G.Barreau, K.Schreckenbach, S.Kerr, H.G.Borner, I.A.Kondurov, Yu.E.Loginov, V.V.Martynov, P.A.Sushkov, H.Seyfarth, T.von Egidy, P.Hungerford, H.H.Schmidt, H.J.Scheerer, A.Chalupka, W.Kane, G.Alaga, Nucl. Phys. A470, 13 (1987)
- 1987Bo52** A.A.Bogdzal, S.T.Boneva, E.V.Vasileva, O.I.Elizarov, Yu.P.Popov, A.M.Sukhovoï, V.A.Khitrov, Yu.S.Yazvitsky, Izv. Akad. Nauk SSSR, Ser. Fiz. 51, 1882 (1987); Bull. Acad. Sci. USSR, Phys. Ser. 51, No. 11, 8 (1987)
- 1987Ca03** R.F.Casten, G.G.Colvin, K.Schreckenbach, J. Phys. (London) G13, 221 (1987)
- 1987Co03** G.G.Colvin, F.Hoyler, S.J.Robinson, J. Phys. (London) G13, 191 (1987)
- 1987CoZW** G.G.Colvin, J.A.Cizewski, H.G.Borner, P.Geltenbort, F.Hoyler, S.A.Kerr, K.Schreckenbach, Pric. Comm. (1987)
- 1987Ge01** W.Gelletly, J.R.Larysz, H.G.Borner, R.F.Casten, W.F.Davidson, W.Mampe, K.Schreckenbach, D.D.Warner, J. Phys. (London) G13, 69 (1987)
- 1987Ha21** S.A.Hamada, W.D.Hamilton, F.Hoyler, J. Phys. (London) G13, 1143 (1987)
- 1987Su05** A.R.H.Subber, S.J.Robinson, P.Hungerford, W.D.Hamilton, P.Van Isacker, K.Kumar, P.Park, K.Schreckenbach, G.Colvin, J. Phys. (London) G13, 807 (1987)
- 1987Wi15** Ch.Winter, B.Krusche, K.P.Lieb, T.Weber, G.Hlawatsch, T.von Egidy, F.Hoyler, Nucl. Phys. A473, 129 (1987)
- 1988BoZH** M.Bogdanovic, J.Simic, M.P.Stojanovic, R.Vukanovic, M.Zupancic, H.G.Borner, G.Colvin, F.Hoyler, K.Schreckenbach, H.Seyfarth, S.Brant, V.Paar, Proc. Int. Conf. Capture Gamma-Ray Spectroscopy 1987, Leuven, Belgium, K. Abrahams, P. van Assche, Eds, p. S553 (1988)
- 1988Co18** G.G.Colvin, S.J.Robinson, F.Hoyler, J. Phys. (London) G14, 1411 (1988)
- 1988CoZU** G.Colvin, Priv. Comm. (1988)
- 1988Ha28** S.A.Hamada, W.D.Hamilton, B.More, J. Phys. (London) G14, 1237 (1988)

- 1988Li30** K.P.Lieb, H.G.Borner, M.S.Dewey, J.Jolie, S.J.Robinson, S.Ulbig, Ch.Winter, Phys. Lett. 215B, 50 (1988)
- 1988Su01** A.R.H.Subber, W.D.Hamilton, P.Van Isacker, K.Schreckenbach, G.Colvin, J. Phys. (London) G14, 87 (1988)
- 1989BoYT** V.A.Bondarenko, S.T.Boneva, E.V.Vasileva, I.L.Kuvaga, Yu.P.Popov, P.T.Prokofev, G.L.Rezvaya, A.M.Sukhovi, V.A.Khitrov, JINR-P6-89-10 (1989)
- 1989Co01** S.P.Collins, S.A.Eid, S.A.Hamada, W.D.Hamilton, F.Hoyler, J. Phys. (London) G15, 321 (1989)
- 1989Du03** P.Durner, T.von Egidy, F.J.Hartmann, Nucl. Instrum. Meth. Phys. Res. A278, 484 (1989)
- 1989Ho15** C.Hofmeyr, Nucl. Phys. A500, 111 (1989)
- 1989Mi16** S.Michaelsen, Ch.Winter, K.P.Lieb, B.Krusche, S.Robinson, T.von Egidy, Nucl. Phys. A501, 437 (1989)
- 1989Ri03** R.Richter, I.Forster, A.Gelberg, A.M.I.Haque, P.von Brentano, R.F.Casten, H.G.Borner, G.G.Colvin, K.Schreckenbach, G.Barreau, S.A.Kerr, H.H.Schmidt, P.Hungerford, H.J.Scheerer, T.von Egidy, R.Rascher, Nucl. Phys. A499, 221 (1989)
- 1989Sc31** H.H.Schmidt, P.Hungerford, T.von Egidy, H.J.Scheerer, H.G.Borner, S.A.Kerr, K.Schreckenbach, F.Hoyler, G.G.Colvin, A.M.Bruce, R.F.Casten, D.D.Warner,, Nucl. Phys. A504, 1 (1989)
- 1989Sh20** R.K.Sheline, R.L.Ponting, A.K.Jain, J.Kvasil, B.bu Nianga, L.Nkwambiaya, Czech. J. Phys. B39, 22 (1989)
- 1989Wi05** Ch.Winter, B.Krusche, K.P.Lieb, S.Michaelsen, G.Hlawatsch, H.Linder, T.von Egidy, F.Hoyler, R.F.Casten, Nucl. Phys. A491, 395 (1989)
- 1990Bo49** S.T.Boneva, E.V.Vasileva, V.D.Kulik, H.H.Le, Yu.P.Popov, A.M.Sukhovi, V.A.Khitrov, Yu.V.Kholnov, Izv. Akad. Nauk SSSR, Ser. Fiz. 54, 822 (1990); Bull. Acad. Sci. Ussr, Phys. Ser. 54, No. 5, 5 (1990)
- 1990Bo52** S.T.Boneva, E.V.Vasileva, V.D.Kulik, L.K.Kkhem, Yu.P.Popov, A.M.Sukhovi, V.A.Khitrov, Yu.V.Kholnov, Izv. Akad. Nauk SSSR, Ser. Fiz. 54, 1787 (1990); Bull. Acad. Sci. USSR, Phys. Ser. 54, No. 9, 118 (1990)
- 1990Ho10** F.Hoyler, J.Jolie, G.G.Colvin, H.G.Borner, K.Schreckenbach, P.Van Isacker, P.Fettweis, H.Gokturk, J.C.Dehaes, R.F.Casten, D.D.Warner, A.M.Bruce, Nucl. Phys. A512, 189 (1990)
- 1990Is02** M.A.Islam, T.J.Kennett, W.V.Prestwich, Phys. Rev. C41, 1272 (1990)
- 1990Is05** M.A.Islam, T.J.Kennett, W.V.Prestwich, Nucl. Instrum. Meth. Phys. Res. A287, 460 (1990)
- 1990Is07** M.A.Islam, T.J.Kennett, W.V.Prestwich, Phys. Rev. C42, 207 (1990)
- 1990Is09** M.A.Islam, T.J.Kennett, W.V.Prestwich, Can. J. Phys. 68, 1237 (1990)
- 1990Ku26** V.T.Kupryashkin, N.V.Strilchuk, A.I.Feoktistov, I.P.Shapovalova, Izv. Akad. Nauk SSSR, Ser. Fiz. 54, 2145 (1990); Bull. Acad. Sci. USSR, Phys. Ser. 54, No. 11, 60 (1990)
- 1990Se17** H.Seyfarth, H.H.Guven, B.Kardon, G.Lhersonneau, K.Sistemich, S.Brant,, Fizika (Zagreb) 22, 183 (1990)
- 1991Bo35** H.G.Borner, R.F.Casten, I.Forster, D.Lieberz, P.von Brentano, S.J.Robinson, T.von Egidy, G.Hlawatsch, H.Lindner, P.Geltenbort, F.Hoyler, H.Faust, G.Colvin, W.R.Kane, M.MacPhail, Nucl. Phys. A534, 255 (1991)
- 1991Da12** W.F.Davidson, W.R.Dixon, J. Phys. (London) G17, 1683 (1991)
- 1991DaZT** W.F.Davidson, W.R.Dixon, PIRS-0288/NRC (1991)
- 1991Is01** M.A.Islam, T.J.Kennett, W.V.Prestwich, Phys. Rev. C43, 1086 (1991)
- 1991Is05** M.A.Islam, T.J.Kennett, W.V.Prestwich, Can. J. Phys. 69, 658 (1991)
- 1991Ke10** J.Kern, A.Raemy, W.Beer, J.-Cl.Dousse, W.Schwitz, M.K.Balodis,

- P.T.Prokofjev, N.D.Kramer, L.I.Simonova, R.W.Hoff, D.G.Gardner, M.A.Gardner, R.F.Casten, R.L.Gill, R.Eder, T.von Egidy, E.Hagn, P.Hungerford, H.J.Scheerer, H.H.Schmidt, E.Zech, A.Chalupka, A.V.Murzin, V.A.Libman, I.V.Kononenko, C.Coceva, P.Giacobbe, I.A.Kondurov, Yu.E.Loginov, P.A.Sushkov, S.Brant, V.Paar, Nucl. Phys. A534, 77 (1991)
- 1991Ki04** S.W.Kikstra, Z.Guo, C.van der Leun, P.M.Endt, S.Raman, T.A.Walkiewicz, J.W.Starner, E.T.Jurney, I.S.Towner, Nucl. Phys. A529, 39 (1991)
- 1991Kl02** N.Klay, F.Kappeler, H.Beer, G.Schatz, H.Borner, F.Hoyler, S.J.Robinson, K.Schreckenbach, B.Krusche, U.Mayerhofer, G.Hlawatsch, H.Lindner, T.von Egidy, W.Andrejscheff, P.Petkov, Phys. Rev. C44, 2801 (1991)
- 1991Ly01** J.E.Lynn, E.T.Jurney, S.Raman, Phys. Rev. C44, 764 (1991)
- 1991Mi08** S.Michaelsen, K.P.Lieb, S.J.Robinson, Z. Phys. A338, 371 (1991)
- 1991MiZQ** S.Michaelsen, K.P.Lieb, L.Ziegeler, T.von Egidy, Proc. Int. Conf. Capture Gamma-Ray Spectroscopy, Pacific Grove, Calif., R. W. Hoff, Ed. , p. 393 (1990); AIP Conf. Proc. 238 (1991)
- 1991NeZX** Zs.Nemeth, KFK 4888 (1991)
- 1991Ra01** S.Raman, T.A.Walkiewicz, S.Kahane, E.T.Jurney, J.Sa, Z.Gacsi, J.L.Weil, K.Allaart, G.Bonsignori, J.F.Shriener, Jr., Phys. Rev. C43, 521 (1991)
- 1991Sa07** S.L.Sakharov, V.L.Alexeev, I.A.Kondurov, E.K.Leushkin, Yu.E.Loginov, V.V.Martynov, V.L.Rumiantsev, P.A.Sushkov, Yu.L.Khazov, A.I.Egorov, H.Lindner, H.Hiller, T.von Egidy, G.Hlawatsch, J.Klora, U.Mayerhofer, H.Trieb, A.Walter, Nucl. Phys. A528, 317 (1991)
- 1992Br17** A.M.Bruce, W.Gelletly, G.G.Colvin, P.Van Isacker, D.D.Warner, Nucl. Phys. A542, 1 (1992)
- 1992Ku17** A.Kuronen, J.Keinonen, H.G.Borner, J.Jolie, S.Ulbig, Nucl. Phys. A549, 59 (1992)
- 1992Ra19** S.Raman, E.T.Jurney, J.W.Starner, J.E.Lynn, Phys. Rev. C46, 972 (1992)
- 1992Wa06** T.A.Walkiewicz, S.Raman, E.T.Jurney, J.W.Starner, J.E.Lynn, Phys. Rev. C45, 1597 (1992)
- 1993Bo01** V.A.Bondarenko, I.L.Kuvaga, P.T.Prokofjev, V.A.Khitrov, Yu.V.Kholnov, Nucl. Phys. A551, 54 (1993)
- 1993Bo29** V.A.Bondarenko, I.L.Kuvaga, L.K.Khiem, Yu.P.Popov, P.T.Prokofjev, A.M.Sukhovoy, P.D.Khang, V.A.Khitrov, Yu.V.Kholnov, Bull. Rus. Acad. Sci. Phys. 57, 42 (1993)
- 1993De01** M.Deleze, S.Drissi, J.Kern, P.A.Tercier, J.P.Vorlet, J.Rikovska, T.Otsuka, S.Judge, A.Williams, Nucl. Phys. A551, 269 (1993)
- 1993Ha05** A.Harder, S.Michaelsen, K.P.Lieb, A.P.Williams, Z. Phys. A345, 143 (1993)
- 1993Ju01** A.Jungclaus, H.G.Borner, J.Jolie, S.Ulbig, R.F.Casten, N.V.Zamfir, P.von Brentano, K.P.Lieb, Phys. Rev. C47, 1020 (1993)
- 1993Ko01** J.Kopecky, M.Uhl, R.E.Chrien, Phys. Rev. C47, 312 (1993)
- 1993Mi04** S.Michaelsen, A.Harder, K.P.Lieb, G.Graw, R.Hertenberger, D.Hofer, P.Schiemenz, E.Zanotti, H.Lenske, A.Weigel, H.H.Wolter, S.J.Robinson, A.P.Williams, Nucl. Phys. A552, 232 (1993)
- 1993Pe04** P.Petkov, W.Andrejscheff, S.J.Robinson, U.Mayerhofer, T.von Egidy, S.Brant, V.Paar, V.Lopac, Nucl. Phys. A554, 189 (1993)
- 1994Co09** C.Coceva, Nuovo Cim. 107A, 85 (1994)
- 1994GrZZ** R.C.Greenwood, Priv. Comm. (1994)
- 1994HoZZ** R.W.Hoff, H.G.Borner, K.Schreckenbach, G.G.Colvin, F.Hoyler, T.von Egidy, R.Georgii, J.Ott, W.Schauer, S.Schrunder, R.F.Casten, R.Gill, M.Balodis, P.Prokofjevs, L.Simonova, J.Kern, O.Bersillon, S.Joly, Priv. Comm. (1994)
- 1994Ki27** T.Kishikawa, K.Nishimura, S.Noguchi, Nucl. Instrum. Methods Phys. Res.

- A353, 285 (1994)
- 1994Ra17** S.Raman, E.T.Jurney, J.W.Starner, A.Kuronen, J.Keinonen, K.Nordlund, D.J.Millener, Phys. Rev. C50, 682 (1994)
- 1995Be02** J.Berzins, P.Prokofjev, R.Georgii, R.Hucke, T.von Egidy, G.Hlawatsch, J.Klora, H.Lindner, U.Mayerhofer, H.H.Schmidt, A.Walter, V.G.Soloviev, N.Yu.Shirikova, A.V.Sushkov, Nucl. Phys. A584, 413 (1995)
- 1995Bo03** V.A.Bondarenko, I.L.Kuvaga, P.T.Prokofjev, A.M.Sukhovoj, V.A.Khitrov,, Nucl. Phys. A582, 1 (1995)
- 1995Bo05** V.A.Bondarenko, I.L.Kuvaga, P.T.Prokofjev, A.M.Sukhovoj, V.A.Khitrov,, Nucl. Phys. A584, 279 (1995)
- 1995Ge06** R.Georgii, T.von Egidy, J.Klora, H.Lindner, U.Mayerhofer, J.Ott, W.Schauer, P.von Neumann-Cosel, A.Richter, C.Schlegel, R.Schulz, V.A.Khitrov, A.M.Sukhovoj, A.V.Vojnov, J.Berzins, V.Bondarenko, P.Prokofjevs, L.J.Simonova, M.Grinberg, Ch.Stoyanov, Nucl. Phys. A592, 307 (1995)
- 1996Co16** C.Coceva, A.Brusegan, C.van der Vorst, Nucl. Instrum. Meth. Phys. Res. A378, 511 (1996)
- 1996Gi09** R.L.Gill, R.F.Casten, W.R.Phillips, B.J.Varley, C.J.Lister, J.L.Durell, J.A.Shannon, D.D.Warner, Phys. Rev. C54, 2276 (1996)
- 1996Ma70** U.Mayerhofer, T.von Egidy, J.Klora, H.Lindner, H.G.Borner, S.Judge, B.Krusche, S.Robinson, K.Schreckenbach, A.M.Sukhovoj, V.A.Khitrov, S.T.Boneva, V.Paar, S.Brant, R.Pezer, Fizika (Zagreb) B5, 167 (1996)
- 1996Ma75** U.Mayerhofer, T.von Egidy, J.Klora, H.Lindner, H.G.Borner, S.Judge, B.Krusche, S.Robinson, K.Schreckenbach, A.M.Sukhovoj, V.A.Khitrov, S.T.Boneva, V.Paar, S.Brant, R.Pezer, Fizika (Zagreb) B5, 229 (1996)
- 1996Ra04** S.Raman, E.K.Warburton, J.W.Starner, E.T.Jurney, J.E.Lynn, P.Tikkanen, J.Keinonen, Phys. Rev. C53, 616 (1996)
- 1996SpZZ** A.Spits, P.H.M.Van Assche, H.G.Borner, W.F.Davidson, K.Schreckenbach,, BLG 703 (1996), edited by A. Spits and P. H. M. Van Assche
- 1997Be42** H.Beer, C.Coceva, R.Hofinger, P.Mohr, H.Oberhummer, P.V.Sedyshev, Yu.P.Popov, Nucl. Phys. A621, 235c (1997)
- 1997BoZW** V.Bondarenko, T.von Egidy, J.Ott, W.Schauer, C.Doll, H.-F.Wirth, J.Honzatko, I.Tomandl, D.Bucurescu, A.Gollwitzer, G.Graw, R.Hertenberger, B.Valnion, Proc. 9th Intern. Symposium on Capture Gamma-Ray Spectroscopy and Related Topics, Budapest, Hungary, October 1996, G. L. Molnar, T. Belgya, Zs. Revay, Eds., Vol. 1, p. 363 (1997)
- 1997Ju02** E.T.Jurney, J.W.Starner, J.E.Lynn, S.Raman, Phys. Rev. C56, 118 (1997)
- 1997Pr02** P.Prokofjevs, L.Simonova, J.Berzins, V.Bondarenko, M.Balodis, A.V.Afanasjev, M.Beitins, M.Kessler, T.von Egidy, T.Koerbitz, R.Georgii, J.Ott, W.Schauer, V.O.Nesterenko, N.A.Bonch-Osmolovskaya, Nucl. Phys. A614, 183 (1997)
- 1998Ba42** M.Balodis, P.Prokofjevs, N.Kramere, L.Simonova, J.Berzins, T.Krasta, R.Georgii, T.von Egidy, J.Klora, H.Lindner, U.Mayerhofer, A.Walter, J.A.Cizewski, G.G.Colvin, H.G.Borner, P.Geltenbort, F.Hoyler, S.A.Kerr, K.Schreckenbach, A.Raemy, J.C.Dousse, J.Kern, W.Schwitz, I.A.Kondurov, Yu.E.Loginov, P.A.Sushkov, S.Brant, V.Paar, V.Lopac, Fizika(Zagreb) B7, 15 (1998)
- 1998Ba85** M.Balodis, P.Prokofjevs, N.Kramere, L.Simonova, J.Berzins, T.Krasta, J.Kern, A.Raemy, J.C.Dousse, W.Schwitz, J.A.Cizewski, G.G.Colvin, H.G.Borner, P.Geltenbort, F.Hoyler, S.A.Kerr, K.Schreckenbach, R.Georgii,

- T.von Egidy, J.Klora, H.Lindner, U.Mayerhofer, A.Walter, A.V.Murzin, V.A.Libman, I.A.Kondurov, Yu.E.Loginov, P.A.Sushkov, S.Brant, V.Paar, V.Lopac, Nucl. Phys. A641, 133 (1998)
- 1998Be19** T.Belgya, B.Fazekas, Zs.Kasztovszky, Zs.Revay, G.Molnar, M.Yeh, P.E.Garrett, S.W.Yates, Phys. Rev. C57, 2740 (1998)
- 1998Ho16** J.Honzatko, I.Tomandl, V.Bondarenko, J.Ott, T.von Egidy, W.Schauer, C.Doll, H.-F.Wirth, A.Gollwitzer, G.Graw, R.Hertenberger, B.Valnion, Fizika(Zagreb) B7, 87 (1998)
- 1999Bo31** V.Bondarenko, J.Honzatko, I.Tomandl, D.Bucurescu, T.von Egidy, J.Ott., Phys. Rev. C60, 027302 (1999)
- 1999Ho01** J.Honzatko, I.Tomandl, V.Bondarenko, D.Bucurescu, T.von Egidy, J.Ott., Nucl. Phys. A645, 331 (1999)
- 2000Bo24** V.Bondarenko, T.von Egidy, J.Honzatko, I.Tomandl, D.Bucurescu, N.Marginean, J.Ott, W.Schauer, H.-F.Wirth, C.Doll, Nucl. Phys. A673, 85 (2000)

DEFINITIONS

E_γ : energy of gamma ray emitted in the decay process from neutron capture.

θ : natural abundance of the capturing isotope involved in the subsequent emission of the prompt gamma ray of interest.

v : speed of neutron.

v_0 : neutron speed of 2200 m s^{-1} .

$\sigma_\gamma(v)$: nuclear capture cross section for neutron of speed v .

σ_0 or $\sigma_\gamma \equiv \sigma_\gamma(v_0)$: thermal neutron capture cross section or the nuclear capture cross section for neutron of speed v_0 .

σ_γ^Z or σ_0^Z : thermal neutron capture cross section for the element (Z) = $\sum_i^{\text{all isotopes}} (\theta \sigma_\gamma)_i$

$P(E_\gamma)$: absolute emission probability of a gamma ray of energy E_γ (gammas per capture).

$\sigma_\gamma(E_\gamma)$: nuclear partial capture cross section = $P(E_\gamma)\sigma_0$.

$\sigma_\gamma^Z(E_\gamma)$: elemental partial capture cross section = $\theta P(E_\gamma)\sigma_0 = \theta \sigma_\gamma(E_\gamma)$; Equation (2) of Chapter 2.

$\hat{\sigma}$: effective capture cross section; definition is given by Equation (3) of Chapter 2.

$\langle \sigma \rangle$: effective capture cross section; definition is given by Equation (5) of Chapter 2.

g_w : Westcott g-factor; definition is given by Equation (12) of Chapter 2.

\hat{g} : effective g-factor; definition is given by Equation (20) of Chapter 2.

k_0 : prompt k_0 factor; definition is given by Equation (1) of Chapter 2.

$k_0(x)$ or $k_0(E_\gamma)$: prompt k_0 factor of the specific gamma ray (of energy E_γ) from element x relative to the hydrogen 2223-keV gamma ray.

At. Wt.: Atomic Weight.

N_γ : Number of gamma rays.

ACRONYMS FOR PROMPT-GAMMA ACTIVATION ANALYSIS

No single abbreviation has been universally agreed in the analytical use of gamma rays from the capture of slow neutrons. The technique has most often been called PGAA or PGNAA during the course of this CRP. The following list has been collected from the literature:

CGA	<u>C</u> apture <u>G</u> amma-ray <u>A</u> nalysis
NCGA	<u>N</u> eutron <u>C</u> apture <u>G</u> amma-ray <u>A</u> nalysis
PCGRA	<u>P</u> rompt <u>C</u> apture <u>G</u> amma-ray <u>A</u> nalysis
PGA	<u>P</u> rompt <u>G</u> amma <u>A</u> nalysis
PGAA	<u>P</u> rompt <u>G</u> amma <u>A</u> ctivation <u>A</u> nalysis
PGNA	<u>P</u> rompt <u>G</u> amma <u>N</u> eutron <u>A</u> nalysis
PGNAA	<u>P</u> rompt <u>G</u> amma-ray <u>N</u> eutron <u>A</u> ctivation <u>A</u> nalysis
PNAA	<u>P</u> rompt <u>N</u> eutron <u>A</u> ctivation <u>A</u> nalysis
PNCAA	<u>P</u> rompt <u>N</u> eutron <u>C</u> apture <u>A</u> ctivation <u>A</u> nalysis
RNC	<u>R</u> adiative <u>N</u> eutron <u>C</u> apture
TCGS	<u>T</u> hermal-neutron <u>C</u> apture <u>G</u> amma-ray <u>S</u> pectroscopy

Additional terms have been used when cold neutrons are employed:

CPGAA	<u>C</u> old <u>P</u> rompt <u>G</u> amma <u>A</u> ctivation <u>A</u> nalysis
CNPGAA	<u>C</u> old <u>N</u> eutron <u>P</u> rompt <u>G</u> amma <u>A</u> ctivation <u>A</u> nalysis
PGCNAA	<u>P</u> rompt <u>G</u> amma <u>C</u> old <u>N</u> eutron <u>A</u> ctivation <u>A</u> nalysis
TNPGAA	<u>T</u> hermal <u>N</u> eutron <u>P</u> rompt <u>G</u> amma <u>A</u> ctivation <u>A</u> nalysis

Other acronym of note:

INAA	<u>D</u> elayed <u>I</u> nstrumental <u>N</u> eutron <u>A</u> ctivation <u>A</u> nalysis
------	------------------------------------------------------------------------------------------

LIST OF PARTICIPANTS

- Choi, H.D. Department of Nuclear Engineering, Seoul National University, Shinrim-dong, Gwanak-ku, Seoul 151-742, Republic of Korea
- Firestone, R.B. Isotopes Project, MS 88R0192, Lawrence Berkeley National Laboratory, University of California, 1 Cyclotron Road, Berkeley, CA 94720, USA
- Frankle, S.C. MS F663, P.O. Box 1663, Los Alamos National Laboratory Los Alamos, NM 87545, USA
- Goswami, A. Nuclear Chemistry Section, Radiochemistry Division, Bhabha Atomic Research Centre, Trombay, Mumbai 400 085, India
- Lindstrom, R.M. Analytical Chemistry Division, Stop 8395, National Institute for Standards and Technology, 100 Bureau Drive, Gaithersburg, MD 20899-8395, USA
- Lone, M.A. Office of the Chief Engineer, Station E4, AECL, Chalk River Laboratories, Ontario, K0J 1J0, Canada
- Molnár, G.L. Nuclear Research Department, Chemical Research Centre, Institute of Isotope and Surface Chemistry, P.O. Box 77, H-1525 Budapest, Hungary
- Mughabghab, S.F. Building 197D, Energy Technology Division, Brookhaven National Laboratory, P.O. Box 5000, Upton, NY 11973-5000, USA
- Nguyen Canh Hai Department of Nuclear Physics and Techniques, Nuclear Research Institute, 1 Nguyen Tu Luc, Dalat, Vietnam
- Reddy, A.V.R. Nuclear Chemistry Section, Radiochemistry Division, Bhabha Atomic Research Centre, Trombay, Mumbai 400 085, India
- Révay, Zs. Nuclear Research Department, Chemical Research Centre, Institute of Isotope and Surface Chemistry, P.O. Box 77 H-1525 Budapest, Hungary
- Zhou, Chunmei China Nuclear Data Centre, China Institute of Atomic Energy, P.O. Box 275 (41), 102413-Beijing, China

