

# Deformation and the Strip Necking Zone in a Cracked Steel Sheet

Moiré method is used to measure the relative opening displacements between crack surfaces and between the upper and lower boundaries of the strip necking region as well as the strain near this region

by B. J. Schaeffer, H. W. Liu and J. S. Ke

**ABSTRACT**—When a tensile stress is applied to a thin cracked plate, a strip necking region results ahead of a crack tip. The relative opening displacement between the crack surfaces and between the upper and lower boundaries of the strip necking region were measured by the moiré method. The strains ahead of the strip necking region and the thickness reduction (therein) were also measured. The measured relative opening displacements were compared with the calculated values using the Dugdale strip necking model. The thickness reduction in the strip necking region is equal to the relative opening displacement.

## Introduction

Knowledge of the state of deformation at a crack tip is important to determine the conditions which led to crack propagation and fracture. Valuable results have been obtained with elastic<sup>1</sup>, elasto-plastic<sup>2,3</sup>, and modified-elastic solutions.<sup>4,5</sup> Empirically, compliance calibration has been used to measure elastic stress-intensity factor<sup>6</sup> and PhotoStress has been used to measure the stress field near a crack tip.<sup>7</sup> Recently, the moiré method has been used to measure the deformation near a crack tip<sup>8,9</sup> and the photoelastic-plastic technique has been used to measure the plastic-zone size in polycarbonate.<sup>10</sup>

When a specimen is very thin, extensive deformation occurs in a thin strip region. This strain concentration is caused by the necking of the material ahead of the crack tip. Figure 1 shows the moiré fringes on the surface of a thin steel specimen under a tensile load. There is a Dugdale strip necking region ahead of each of the tips of the slot. When necking takes place, the material above and below the necked region deforms little as the load is further increased. Therefore the upper and lower boundaries of the strip necking region can be treated as "elastic". This is especially correct if the material is elastic and perfectly plastic. The relative opening displacement between the upper and the lower boundaries increases with the applied load. The deformation of such a cracked thin plate was first analyzed by Dugdale<sup>4</sup> and subsequently by Goodier and Field<sup>5</sup> and Bilby, Cottrell and Swinden.<sup>11</sup>

*B. J. Schaeffer, H. W. Liu and J. S. Ke are Research Fellow, Professor and Research Assistant, respectively, Department of Chemical Engineering and Metallurgy, Syracuse University, Syracuse, N. Y. 13210.*

*This report was produced under contracts sponsored by AISI and NASA. The conclusions and recommendations expressed are those of the authors and are not necessarily endorsed by the sponsor.*

Swedlow et al<sup>2</sup> have calculated stresses and strains near a crack tip for a two-dimensional plane-stress case. Their calculation shows a diffused deformed region in contrast with the strip deformed region as assumed by the Dugdale model. Drucker and Rice<sup>3</sup> attributed the difference primarily to the yield conditions used by these two calculations. While the Tresca yield condition was used for the Dugdale model, the Mises' yield condition was used by Swedlow et al.<sup>2</sup> Consequently, Drucker and Rice<sup>3</sup> concluded that material obeying Tresca's yield criterion should have a strip necking region, while materials obeying Mises' yield criterion should show a diffused region of intensive deformation. The regions of intensive deformation based on these two calculations are shown schematically in Fig. 2. In this study, the relative opening displacements between crack surfaces and between the upper and lower boundaries of the strip necking region, as well as the strain near the strip necking region, were measured using the moiré method. The measured opening displacements were compared with the calculated values. The thickness reduction in the strip necking region was also measured.

## Experimental Method

The relative opening displacements between crack surfaces and the upper and lower boundaries of the strip necking region, and the strain near the strip necking region were measured with the moiré technique. Two thin steel specimens with central slots were tested. The slot is a jewel-saw cut, 1-in. long and 0.007-in. wide. The specimens are 6-in. wide and 0.012-in. thick. The tensile stress-strain curve is shown in Fig. 3. The 0.2-percent offset yield strength is 91 ksi. Two specimens were tested. One was loaded to 55 ksi and the deformation was measured under load. The other was loaded to 62 ksi and the deformation was measured after unloading.

The specimen surface was polished, cleaned and coated with photo-resist. The moiré grille was printed onto the specimen surface with lines parallel to the slot. A line density of 13,400 lines per inch (lpi) was used. The moiré fringes were obtained by double exposures before and after deformation.

## Results and Discussion

Figure 1 shows a picture of moiré fringes. The ap-

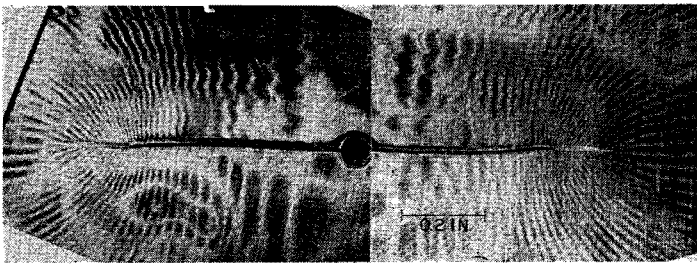

Fig. 1—Moiré pattern of a steel specimen: applied stress, 55 ksi; 0.2-percent-offset yield stress, 91 ksi; Young's modulus,  $32 \times 10^6$  psi; 0.012-in. thick; 6-in. wide; slot length, 1.0 in.; pitch of moiré grille,  $1/13,400$  in.

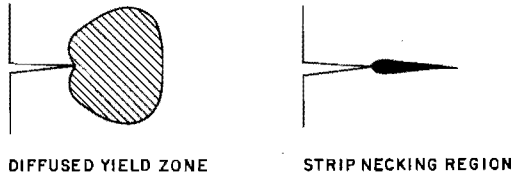

Fig. 2—Schematic diagrams of diffused yield zone and strip necking region

plied stress is 55 ksi. The slot is 1-in. long. The Dugdale strip necking region is clearly visible. Along each fringe, the displacement in the loading direction is constant. The relative displacement between two neighboring fringes is equal to the pitch of the grille lines, i.e.,  $1/13,400$  in. The relative opening displacements between the crack surfaces and between the upper and lower boundaries of the Dugdale strip necking region were measured and plotted as the solid line in Fig. 4. In the strip necking region, the accuracy is  $\pm 50 \mu\text{in}$ .

The crack-opening displacement  $v$  along the crack line has been calculated by Goodier and Field<sup>5</sup> using the Dugdale model.

$$v(x, a) = \frac{\sigma_Y l}{\pi E} \left[ \cos\theta \log \frac{\sin^2(\theta_2 - \theta)}{\sin^2(\theta_2 + \theta)} + \cos\theta_2 \log \frac{(\sin\theta_2 + \sin\theta)^2}{(\sin\theta_2 - \sin\theta)^2} \right] \quad (1)$$

where

$$\cos\theta_2 = \frac{a}{l}$$

$$\cos\theta = \frac{x}{l} \text{ for } |x| < l, -\pi < \theta < \pi$$

$$\theta_2 = \frac{\pi\sigma}{2\sigma_Y}$$

$\sigma$  and  $\sigma_Y$  are the applied stress and the tensile yield stress of the material.  $a$  is the half-crack length.  $l$  is the half-crack length plus the length of the strip necking region, and  $E$  is Young's modulus. The calculated opening displacements are shown as the dashed line in Fig. 4. Values of  $32 \times 10^6$  psi and 91 ksi for  $E$  and  $\sigma_Y$  were used for the calculations. The relative opening displacement is  $2v$ .

In the central region of the crack surface, the measured values of the relative opening displacements are

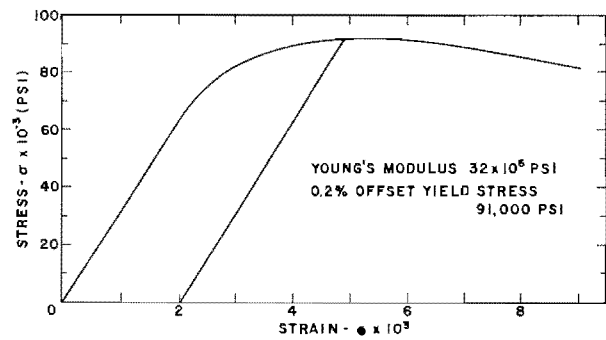

Fig. 3—Tensile stress-strain curve of a thin steel sheet

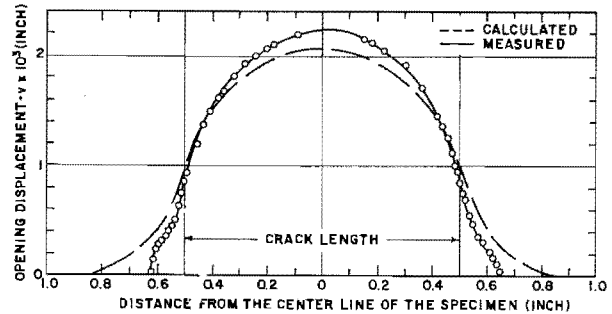

Fig. 4—Opening displacement along crack line:  $\sigma$ , 55 ksi;  $\sigma_Y$ , 91 ksi;  $E$ ,  $32 \times 10^6$  psi; thickness, 0.012 in.; width, 6 in.; slot length, 1.0 in.

higher than the calculated values. The deviation is approximately 10 percent. The opening displacements in the central region of the crack reflect the extent and the intensity of the deformation of the cracked section of the sheet. As indicated by eq (1), the deformation of the cracked section increases with the ratio  $\sigma/\sigma_Y$ . The steel strain hardens considerably. The proportional limit is in the neighborhood of 65 ksi and the 0.2-percent-offset yield stress is 91 ksi. A slightly lower value of  $\sigma_Y$  in the calculation will give a better agreement between the measurements and the calculation.

The measured opening displacements are lower than the calculated values in the strip necking region. The measured and the calculated values at the ends of the slot are  $0.86 \times 10^{-3}$  in. and  $1.01 \times 10^{-3}$  in., respectively. The Dugdale model assumes that the deformation is confined to the strip necking region, and the material outside of the region deforms elastically. The stress within the strip is uniaxial, equal to  $\sigma_Y$ . This is probably correct if a material is elastic and perfectly plastic. But most materials strain harden. If a material strain hardens, plastic deformation takes place outside of the strip necking region, before necking takes place.

When the stresses and the deformations increase in the cracked section, two opposing effects affect the load-carrying capacity of the material ahead of a crack tip. The load-carrying capacity is increased by the strain hardening of the material, and it is reduced by the decrease of the cross-sectional area. For a simple tensile test, necking takes place when the effect of area reduction overtakes the effect of strain hardening. If a material strain hardens strongly, necking takes place only after extensive deformation occurs throughout the test section of a tensile speci-

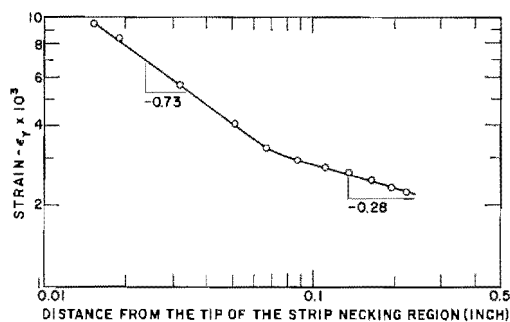

Fig. 5—Strain ahead of the strip necking region

men. In the case of localized necking ahead of a crack tip, the situation is complicated by the stress gradient in this region. When a steep stress gradient is present, necking may take place at a much lower strain level in the local region ahead of a crack tip. Therefore, both the rate of strain hardening and the stress gradient affect the plastic deformation outside of the strip necking region. The deformation outside of the strip necking region is evident by examining the moiré fringes in Fig. 1. The fringe spacing corresponding to the yield strain of the steel is 0.027 in. It is evident that plastic deformation takes place above, below and ahead of the strip necking region. Figure 5 shows the logarithmic plot of the strains ahead of the strip necking region and along the crack line. Two straight-line segments correlate the data well. Near the tip of the strip necking region, the strains decrease with  $(r)^{-0.73}$ , where  $r$  is the distance from the tip of the strip necking region. The yield strain of the steel is  $2.8 \times 10^{-3}$  in./in., and the plastic-zone size from the tip of the strip necking region is 0.09 in. It is close to the intersection of these two line segments.

It is evident that strip necking region is imbedded in a diffused plastically deformed region as shown schematically in Fig. 6. This picture of deformation was first suggested by McClintock.<sup>12</sup> The strip necking is the result of the reduction of the cross-sectional area ahead of a crack tip, which causes the reduction of the load-carrying capacity of the material element regardless of the yield criteria which a material obeys.

The calculated length of the strip necking region is 0.36 in., the measured length is 0.14 in., whereas the total length of the necked region and the diffused plastic zone ahead of it is 0.23 in. The measured total length of the plastically deformed region is much less than the calculated strip necking region. It is expected that the length of a strip necking region using the Dugdale model should be longer than the size of the diffused plastically deformed region given by Swedlow's two-dimensional elasto-plastic plane-stress calculation. Therefore, the total length of the strip necking region and the diffused plastic region in the steel specimen should be less than the calculated length of the strip necking region.

Liu<sup>13</sup> has suggested that, when necking takes place, deformation is the result of shears on two sets of orthogonal planes, each inclined 45 deg to the loading axis, as shown schematically in Fig. 7. The 45 deg inclined shear planes were verified by Hahn and

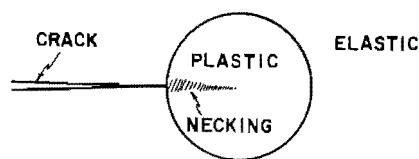

Fig. 6—Schematic diagram of the various regions of deformation around a crack

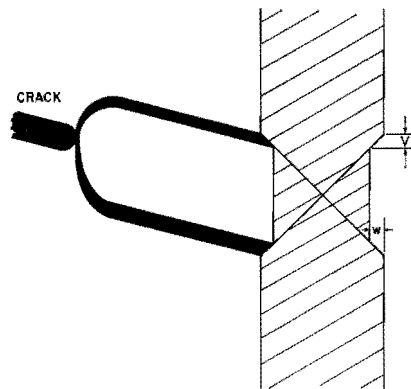

Fig. 7—Schematic diagram for necking zone ahead of a crack

Rosenfield,<sup>14</sup> experimentally, with etching studies on silicon iron.

The strain concentration in the necked region will increase the fatigue-crack-propagation rate. Liu has also used strain concentration in the necked region to explain the rapidly increased fatigue-crack-propagation rate  $da/dN$  as the applied stress-intensity-factor range,  $\Delta K$ , increases. This strain concentration may lead to a relation that  $da/dN$  is proportional to  $\Delta K^4$ .<sup>15</sup> Therefore, the necking process affects both fracture toughness of thin sheets and the fatigue-crack-propagation rate.

The simple model in Fig. 7 indicates that the relative opening displacement is equal to the reduction of the thickness. Figure 8 shows the opening displacements and the thickness reduction in the strip necking region. Both the opening displacements and the thickness reduction were measured after unloading. The applied stress was 62 ksi. The specimen width, thickness, and the slot length were 6 in., 0.012 in. and 1.0 in., respectively. The opening displacements were measured by the moiré method. The thickness reductions were measured with a microscope. The microscope was focussed first on the specimen surface, then on the bottom of the necked region. The reduction of the specimen thickness is the difference of the readings on the micrometer, which is attached to the microscope for focus adjustment. Because of the shallow depth of focussing at high magnification, the thickness reduction can be measured accurately. Both measurements agree with each other exceedingly well. The maximum deviation at the end of the slot is approximately 10 percent. The simple model shown in Fig. 7 indicates two shear planes orthogonal to each other,

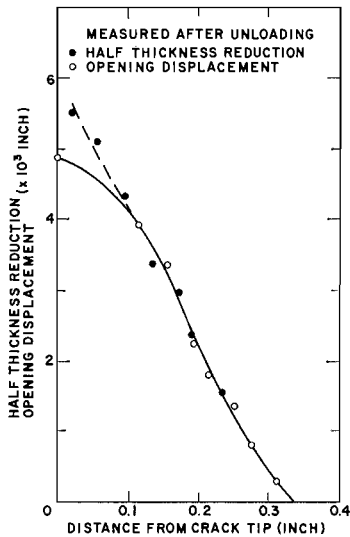

Fig. 8—Half-thickness reduction and opening displacement in the strip necking region of a steel specimen.  $\sigma$ , 62 ksi

and the deformation leads to a stepped surface. This picture is shown for the simplicity of presentation. Shear deformation occurs on two orthogonal sets of parallel shear planes. The shears on these planes give a gradual thickness reduction to the bottom of the necked region, rather than the abrupt thickness reduction shown in Fig. 7.

If one assumes that the in-plane lateral strain is zero, the longitudinal tensile strain at the bottom of the necked region is equal to the contraction strain in the thickness direction. Hence, the tensile strain is given by

$$\epsilon = \frac{2v}{t} \quad (2)$$

where  $t$  is the sheet thickness. For the same value of opening displacement, a thinner specimen gives a higher strain. This relation is reasonable for a very thin specimen.

The fracture toughness of a material increases from the plane-strain fracture-toughness value to an optimum value as the plate thickness reduces. As the thickness is further reduced beyond the optimum point, the fracture toughness reduces.<sup>16</sup> Liu<sup>17</sup> has used the concept of strain concentration in the necked region to explain the reduction in fracture toughness as the sheet thickness decreases beyond the optimum point. It was assumed that  $\epsilon_{ave}$  at the crack tip in the necked region is a constant at fracture. The relative crack-opening displacement is related to the strain-intensity factor

$$2v = \frac{K^2}{E\sigma_Y} \quad (3)$$

Equations (2) and (3) lead to a fracture toughness,

$$K_c = \sqrt{E\sigma_Y \epsilon_c t} \quad (4)$$

where  $\epsilon_c$  is the critical strain at the crack tip at frac-

ture. Hence  $K_c$  is proportional to  $\sqrt{t}$ . However, as the sheet thickness is close to the optimum point of highest fracture toughness, the relation in eq (2) may not be valid. For most of materials, the optimum point occurs when a plate is fairly thick. Therefore the strip necking model is not applicable.

## Conclusions

1. For a material that strain hardens, the Dugdale strip necking region is imbedded in a diffused region of plastic deformation.
2. The strip yielding region is primarily caused by necking, i.e., the thickness reduction in the area ahead of a crack tip.
3. The thickness reduction in the strip necking region is equal to the relative opening displacement. The strain at the bottom of the necked region is approximately given by  $\epsilon_{ave} = 2v/t$ .

## Acknowledgment

The work was conducted at the Metallurgical Research Laboratories of Syracuse University. The support of both American Iron and Steel Institute (to JSK) Contract No. 123, and NASA (to BJS) Grant No. NGR-33-022-105 is acknowledged. The assistance by Mmes. H. Turner and B. Howden in the preparation of the manuscript is also acknowledged.

## References

1. Paris, P. C. and Sih, G. C., "Stress Analysis of Cracks," *Fracture Toughness Testing and Its Applications*, ASTM STP 381, 30-83 (1965).
2. Suedlow, J. L., Williams, M. L. and Yang, W. H., "Elasto-Plastic Stress and Strains in Cracked Plates," *Proc. First Internat. Conf. on Fracture, Sendai, Japan, 1*, 259-282 (1965).
3. Drucker, D. C. and Rice, J. R., "Plastic Deformation in Brittle and Ductile Fracture," *Engineering Fracture Mechanics*, 1, 577-602 (1970).
4. Dugdale, D. S., "Yielding of Steel Sheets Containing Slits," *Jnl. of Mech. and Phys. of Solids*, 8, 100-104 (1960).
5. Goodier, J. N. and Field, F. A., "Plastic Energy Dissipation in Crack Propagation," *Fracture of Solids*, Interscience, New York, 103-118 (1963).
6. Gross, B., Srawley, J. E. and Brown, Jr., W. F., "Stress Intensity Factors for a Single-Edge-Notch Tension Specimen by Boundary Collocation of a Stress Function," NASA TN D-2395, (1964).
7. Gerberich, W. W., "Plastic Strains and Energy Density in Cracked Plates—Part I—Experimental Technique and Results," *EXPERIMENTAL MECHANICS*, 4 (11), 335-344 (Nov. 1964).
8. Underwood, J. H. and Kendall, D. P., "Measurement of Microscopic Plastic-strain Distributions in the Region of a Crack Tip," *EXPERIMENTAL MECHANICS*, 9 (7), 296-304 (July 1969).
9. Liu, H. W., Gavigan, W. J. and Ke, J. S., "An Engineering Analysis of Ductile Fractures," *Internat. Jnl. of Fracture Mechanics*, 6 (1) (1970).
10. Brinson, H. F., "The Ductile Fracture of Polycarbonate," *EXPERIMENTAL MECHANICS*, 10 (2), 72-77 (Feb. 1970).
11. Bilby, B. A., Cottrell, A. H. and Swinden, K. H., "The Spread of Plastic Yield from a Notch," *Proc. Royal Society*, 272, Series A (1963).
12. McClintock, F. A., "Discussion on Fracture Mode Transition for a Crack Traversing a Plate," *Trans. ASME, Jnl. of Basic Engrg.*, 82, 423 (1960).
13. Liu, H. W., "Discussion on W. Weibull's Paper on the Effect of Size and Stress History on Fatigue Crack Initiation and Propagation," *Proc. of the Internat. Symp. on Crack Propagation, Cranfield, England (1961)*.
14. Rosenfield, A. R., Dai, P. K. and Hahn, G. T., "Crack Extension and Propagation Under Plane Stress," *Proc. First Internat. Conf. on Fracture, Sendai, Japan, 1*, 223-258 (1965).
15. Liu, H. W., "Fatigue Crack Propagation and the Stresses and Strains in the Vicinity of a Crack," *Applied Materials Research*, (Oct. 1964).
16. Irwin, G. R., Kies, J. A. and Smith, H. L., "Fracture Strengths Relative to Onset and Arrest of Crack Propagation," *Proc. Am. Soc. Testing Materials*, 58, 640 (1958).
17. Liu, H. W., "Yielding Initiation Process and Its Effect on Fracture of Cracked Plate," *Proc. First Internat. Conf. on Fracture, Sendai, Japan, 1*, 191-212 (1965).