

# Demonstration of Extinction Ratio Improvement From 2 to 9 dB and Intensity Noise Reduction With the MZI-GCSOA All-Optical 2R Regenerator

Mingshan Zhao, Geert Morthier, *Senior Member, IEEE*, and Roel Baets, *Senior Member, IEEE*

**Abstract**—In this letter, we experimentally demonstrate improved static and dynamic characteristics of the all-optical 2R regenerator based on a Mach–Zehnder interferometer with gain-clamped semiconductor optical amplifiers. A true digital-like optical decision characteristic with an adjustable decision threshold has been found. A tremendous noise suppression at the logic “0” and a large improvement in the extinction ratio have been obtained even for a very deteriorated input signal with small extinction ratio at a bit rate of 2.488 Gb/s. An 8-dB improvement in extinction ratio can be achieved for an input extinction ratio of 5- and 7-dB improvement for an input extinction ratio of 2 dB. Furthermore, a good regeneration is achieved over a broad wavelength range of 20 nm.

**Index Terms**—All-optical regeneration, optical communication, optical pulse shaping, semiconductor optical amplifiers.

## I. INTRODUCTION

IN FUTURE LARGE-SCALE and high bit rate optical networks, all-optical regeneration will be the key technique to suppress signal degradations induced by accumulation of noise and dispersion. This regeneration can be either 2R regeneration, consisting of signal reshaping, or 3R regeneration, consisting of signal reshaping and retiming. Although 3R regenerators are generally preferred for application in high bit rate systems, 2R regenerators may be useful in parts of an optical network. The quality of an optical 2R regenerator can be defined by its ability of noise reduction and extinction ratio improvement, two factors that can be derived from the optical decision characteristic. The regenerator offering the best regenerative properties must have an optical decision characteristic as close as possible to the digital (step-like) characteristic. However, the decision characteristics of the optical regenerators proposed recently, such as semiconductor optical amplifier (SOA)-based interferometric wavelength converters [1], [2], SOA-based Mach–Zehnder or Michelson interferometers [3], [4] and regenerators based on saturable absorbers [5], were not truly digital in the sense that the slope of the regeneration characteristic was rather slow. For getting a steeper decision characteristic, cascaded regenerator structures are normally needed [2]. A novel all-optical 2R regenerator which gives a true digital-like decision characteristic,

a flexible adjustment of decision threshold and does not require wavelength conversion has been theoretically proposed [6] earlier by the authors and verified by preliminary experimental results [7]. Here, we present more detailed experimental results of the static and dynamic characteristics of the 2R regenerator, which clearly demonstrate a quasi-ideal optical decision characteristic and excellent regeneration capabilities.

## II. EXPERIMENTS

The regenerator has a Mach–Zehnder interferometric structure with gain-clamped SOAs (GCSOAs) in both arms. The operation of this regenerator is based on the specific property of a GCSOA that its amplification in the linear regime is independent of the injected current, whereas the saturation power increases linearly with the injected current, which has been explained in [6], [7]. The two GCSOAs in the Mach–Zehnder interferometer (MZI) are, in principle, identical and have different bias applied to them. In the linear regime, both arms of the (MZI) give the same signal gain and a phase delay that differs by a constant  $\pi$ . As a result, a completely destructive interference below the input saturation powers of both GCSOAs is obtained at the output of the MZI. Beyond the saturation power of both GCSOAs, the phase difference between both arms is also constant, but now different from  $\pi$  and the output powers from both GCSOAs are saturated, such that a constant output power is also obtained at the output of the MZI and hence a digital-like decision characteristic is achieved with the MZI regenerator. Fig. 1 shows the regenerator and the experimental setup used. This MZI 2R regenerator can in principle be integrated. For our experiments, however, the MZI was built using fiber-optic 3-dB splitters and two commercial packaged GCSOAs [8]. The two GCSOAs happen to exhibit considerably different amplification and equal gain in both interferometer arms is achieved using an extra variable attenuator in one arm. The temperature control of one of the packaged GCSOA was used to obtain destructive interference at a low input power level. To avoid instabilities due to airflow, the fiber-optic interferometer is concealed in a plastic box. At the output, an optical filter with 3-dB bandwidth of 0.3 nm is used to suppress the laser signals and the amplified spontaneous emission from the GCSOAs. A tunable laser source (Model Tunics-plus, Photonics), an external modulator and a pulse generator are combined and used as a transmitter. The optical data signal at 2.488 Gb/s (PRBS =  $2^{23} - 1$ , RZ format) is first transmitted through

Manuscript received January 8, 2002; revised March 26, 2002. This work has been supported in part by the European Union IST under Project STOLAS.

The authors are with the Department of Information Technology, Ghent University-IMEC, B-9000 Gent, Belgium (e-mail: mszhao@intec.rug.ac.be; morthier@intec.rug.ac.be; baets@intec.rug.ac.be).

Publisher Item Identifier S 1041-1135(02)05293-X.

an erbium-doped fiber amplifier (EDFA) and then coupled into the MZI. The extinction ratio of the data signal can be controlled by changing the driving

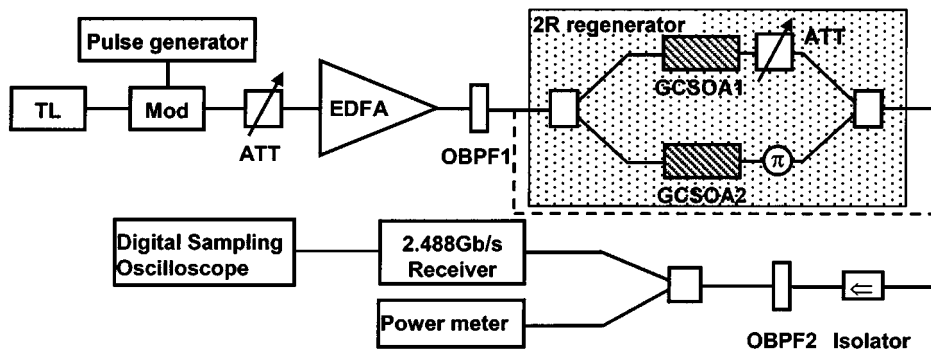

Fig. 1. Experimental setup for 2R regenerator based on a MZI with equal GCSOAs in both arms. TL: Tunable laser. ATT: Attenuator. Mod: Mach-Zehnder modulator. The dashed line indicates the setup without the 2R regenerator.

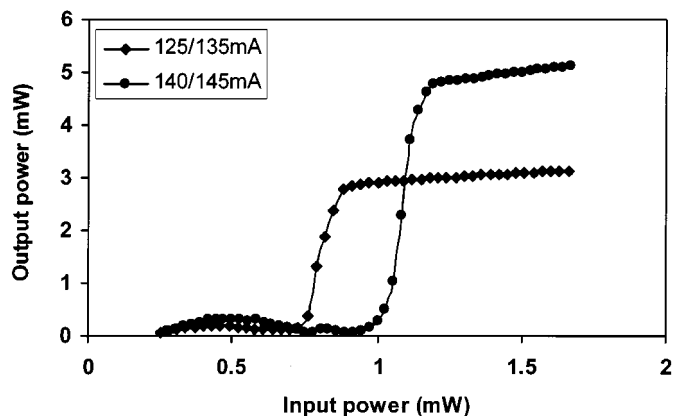

Fig. 2. Measured static decision characteristic for different bias currents to the GCSOAs.

pulse amplitude (i. e., electrical pulse signal amplitude) of the external modulator. The optical bandpass filter (OBPF) behind the EDFA has a 3-dB bandwidth of 0.2 nm and the same central wavelength as the filter at the output of the MZI.

### III. RESULTS AND DISCUSSION

The measured static decision characteristic for the MZI is shown in Fig. 2. The bias currents applied to the two GCSOAs are 140/145 and 125/135 mA, respectively, and the signal wavelength is 1553.3 nm. As can be seen, the decision characteristic has a true digital-like shape. For both a logical “1” (high-power level) and a logical “0” (low-power level) quasi-perfect regeneration is achieved, which is consistent with the simulation result given in [6]. The output power shifts from the low to the high level over an input power range of about 0.2 mW at a threshold input power of 1.0 mW for the bias currents of 140/145 mA. This means that under static conditions an output extinction ratio of 15 dB can be obtained for an input extinction ratio of less than 1 dB. We note that this is in sharp contrast with the sinusoidal-like regeneration obtained from most other regenerators that have been proposed so far (cf. [1], [2]). For different bias currents to the GCSOAs, the results demonstrate very clearly a

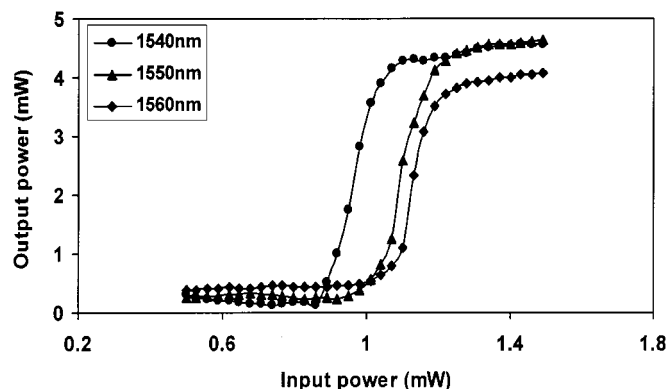

Fig. 3. Regeneration characteristics for different wavelengths, bias currents of two GCSOAs: 135 and 147 mA, respectively.

significant shift of the decision threshold. Therefore, a very flexible adjustment of the decision threshold can be achieved easily by altering the bias current to the GCSOAs.

An important feature for practical use of all-optical regeneration is wavelength insensitivity. Fig. 3 shows the measured decision characteristics for different signal wavelengths, with the same bias currents being applied to the GCSOAs. Clearly, good regeneration has been obtained over a broad wavelength range from 1540 to 1560 nm. A decision threshold shift of  $\sim 1$  dB for a wavelength range of 20 nm is due to the fact that the saturation input power of the fiber-pigtailed GCSOAs changes with the signal wavelength.

The regenerative capabilities of the regenerator under dynamic operation are demonstrated in Figs. 4 and 5. Fig. 4 shows the eye diagrams with and without the 2R regenerator for different input extinction ratios, while Fig. 5 shows the extinction ratio improvement, both figures are obtained for a signal with a bit rate of 2.488 Gb/s. Clearly, the input signal is regenerated. Both the level and the noise at the logic “0” are tremendously suppressed and great improvements of both extinction ratio and signal to noise ratio are demonstrated. For an input extinction ratio of 5 dB, 8-dB improvement in extinction ratio is obtained. Even for a very deteriorated input signal with an extinction of 2 dB, an extinction ratio improvement of 7 dB is still achieved. This result is in

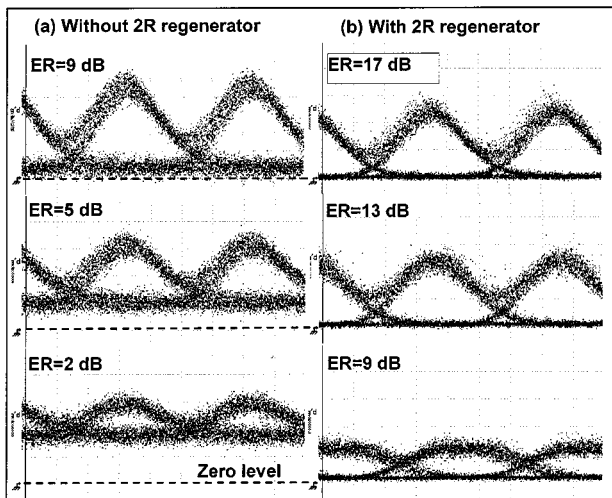

Fig. 4. Eye diagrams with and without the 2R regenerator for signals with different extinction ratios at 2.488 Gb/s. Signal wavelength: 1553.3 nm. ER: Extinction ratio.

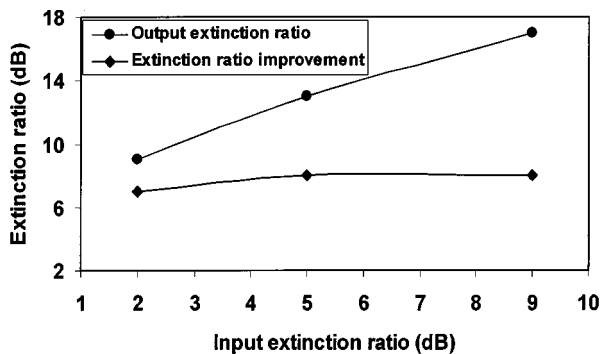

Fig. 5. Output extinction ratio and its improvement as a function of input extinction ratio at 2.488 Gb/s.

contrast with that in [3], where the maximum improvement of extinction ratio was 4 dB with an input extinction ratio of 6 dB. As the noise at the logic “0” is strongly suppressed, there is no doubt that a large improvement in signal to noise ratio can also be achieved with the regenerator, although no significant intensity noise suppression at the logic “1” is observed. Indeed, it can be noticed that the noise suppression for a logic “1” is not as good as expected. This is due to extra noise induced by the relaxation oscillations as well as by an instability of the laser mode near the saturation power of the GCSOAs. The instability of the laser mode near the threshold might result from some weak back reflection in the hybrid fiber-based device. We believe that an integrated version of the device would show better noise suppression

at both logic “0” and “1”. Furthermore, recent developments indicate that very high-speed GCSOAs can be fabricated [9]. With such high-speed GCSOAs, the regenerator proposed here should be capable of operation at 10 Gb/s or multiples of that bit rate.

#### IV. CONCLUSION

We have presented quasi-ideal optical decision characteristics, measured on a MZI with GCSOAs in both arms. The decision characteristic has an adjustable threshold and exhibits a very sharp transition between low and high output power. Dynamic measurements at 2.488 Gb/s demonstrate a tremendous intensity noise suppression at the logic “0” and a large improvement in the extinction ratio even for a very deteriorated input signal with small extinction ratio: e.g., 8-dB improvement in extinction ratio has been obtained for an input extinction ratio of 5- and 7-dB improvement for an input extinction ratio of 2 dB. Furthermore, a good regeneration over a broad wavelength range of 20 nm is also demonstrated. Therefore, taking the simplicity of the device and the excellent regeneration characteristic into account, this approach is a promising technique for 2R all-optical regeneration.

#### REFERENCES

- [1] B. Lavigne, D. Chiaroni, L. Hamon, C. Janz, and A. Jourdan, “Experimental analysis of SOA based 2R and 3R optical regeneration for future WDM networks,” in Tech. Dig. OFC, San Jose, CA, 1998, Paper Th07.
- [2] B. Lavigne, D. Chiaroni, P. Guerber, L. Hamon, and A. Jourdan, “Improvement of regeneration capabilities in semiconductor optical amplifier-based 3R regenerator,” in Tech. Dig. OFC, San Diego, CA, 1999, Paper TuJ3.
- [3] D. Wolfson, P. B. Hansen, A. Kloch, and K. E. Stubkjaer, “All-optical 2R regeneration based on interferometric structure incorporating semiconductor optical amplifiers,” *Electron. Lett.*, vol. 35, pp. 59–60, 1999.
- [4] J. De Merlier, G. Morthier, S. Verstuyft, T. Van Caenegem, I. Moerman, P. Van Daele, and R. Baets, “A novel 2R regenerator based on an asymmetric Mach-Zehnder interferometer incorporating an MMI-SOA,” in Proc. LEOS Annual Meeting, San Diego, CA, 2001.
- [5] T. Otani, T. Miyazaki, and S. Yamamoto, “Optical 3R regenerator using wavelength converters based on electroabsorption modulator for all-optical network applications,” *IEEE Photon. Technol. Lett.*, vol. 12, pp. 431–433, Apr. 2000.
- [6] G. Morthier, J. Sun, and R. Baets, “A novel optical decision circuit based on a Mach-Zehnder or Michelson interferometer and gain-clamped semiconductor optical amplifiers,” *IEEE Photon. Technol. Lett.*, vol. 10, pp. 1162–1164, Aug. 1998.
- [7] G. Morthier, M. Zhao, B. Vanderhaegen, and R. Baets, “Experimental demonstration of an all optical 2R regenerator with adjustable decision threshold and ‘true’ regeneration characteristics,” *IEEE Photon. Technol. Lett.*, vol. 12, pp. 1516–1518, Nov. 2000.
- [8] GCSOA’s Were Acquired From Alcatel [Online]. Available: <http://www.alcatel.com>
- [9] D. A. Francis, S. P. DiJaili, and J. D. Walker, “A single-chip linear optical amplifier,” in Tech. Dig. OFC, Anaheim, CA, 2001, Postdeadline Paper PD13.