

AD-A123 970

DESCRIPTOR VARIABLE AND GENERALIZED SINGULARLY  
PERTURBED SYSTEMS: A GEOMETRIC APPROACH(U) ILLINOIS  
UNIV AT URBANA DECISION AND CONTROL LAB J D COBB  
MAY 80 DC-38 N00014-79-C-0424

1/2

UNCLASSIFIED

F/G 12/1

NL

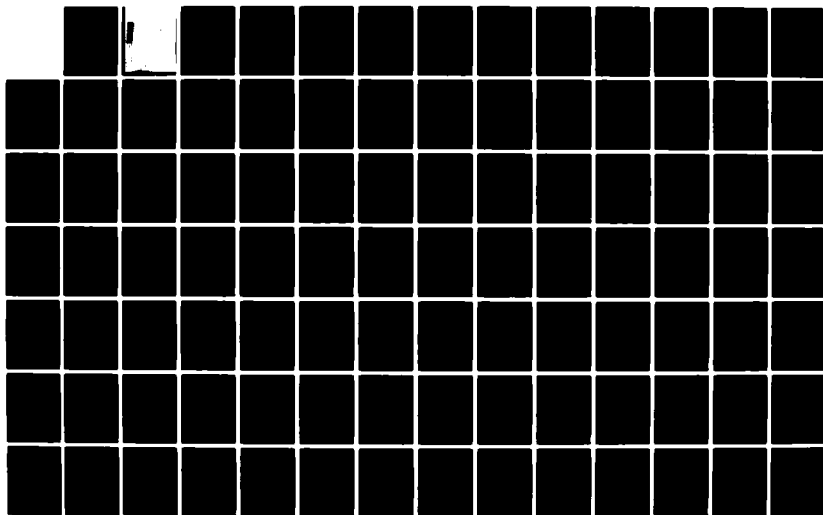

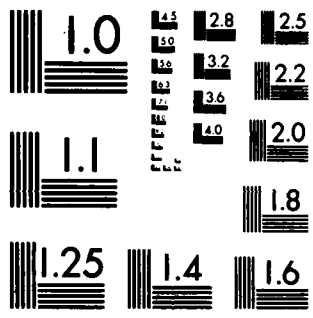

MICROCOPY RESOLUTION TEST CHART  
NATIONAL BUREAU OF STANDARDS-1963-A

ADA 123970

UNCLASSIFIED

SECURITY CLASSIFICATION OF THIS PAGE (When Data Entered)

REPORT DOCUMENTATION PAGE		READ INSTRUCTIONS BEFORE COMPLETING FORM
1. REPORT NUMBER	2. GOVT ACCESSION NO.	3. RECIPIENT'S CATALOG NUMBER
	A123970	
4. TITLE (and Subtitle) DESCRIPTOR VARIABLE AND GENERALIZED SINGULARLY PERTURBED SYSTEMS: A GEOMETRIC APPROACH		5. TYPE OF REPORT & PERIOD COVERED Technical Report
7. AUTHOR(s) J. Daniel Cobb		6. PERFORMING ORG. REPORT NUMBER R-882(DC-38); UILU-80-2214
9. PERFORMING ORGANIZATION NAME AND ADDRESS Coordinated Science Laboratory University of Illinois at Urbana-Champaign Urbana, Illinois 61801		8. CONTRACT OR GRANT NUMBER(s) AFOSR-78-3633 NSF ECS-79-19396 N00014-79-C-0424
11. CONTROLLING OFFICE NAME AND ADDRESS Joint Services Electronics Program		10. PROGRAM ELEMENT, PROJECT, TASK AREA & WORK UNIT NUMBERS
14. MONITORING AGENCY NAME & ADDRESS (if different from Controlling Office)		12. REPORT DATE May 1980
		13. NUMBER OF PAGES 105
		15. SECURITY CLASS. (of this report) UNCLASSIFIED
		15a. DECLASSIFICATION/DOWNGRADING SCHEDULE
16. DISTRIBUTION STATEMENT (of this Report)  Approved for public release; distribution unlimited.		
17. DISTRIBUTION STATEMENT (of the abstract entered in Block 20, if different from Report)		
18. SUPPLEMENTARY NOTES		
19. KEY WORDS (Continue on reverse side if necessary and identify by block number)  Descriptor variable systems Linear feedback Singularly perturbed systems Convergence of solutions		
20. ABSTRACT (Continue on reverse side if necessary and identify by block number)  Existing results in descriptor variable theory are interpreted geometrically. New results are obtained concerning linear feedback and pole placement in such systems. Descriptor variable systems are viewed as limits of singularly perturbed systems. It is shown that some important singularly perturbed systems cannot be treated effectively with standard techniques. Hence, a generalized class of singularly perturbed systems is considered. A geometric decomposition that preserves continuity about the singular point is derived. Conditions are presented under which the solution of a singularly perturbed system converges		

DD FORM 1 JAN 73 1473 EDITION OF 1 NOV 65 IS OBSOLETE

UNCLASSIFIED

SECURITY CLASSIFICATION OF THIS PAGE (When Data Entered)

20. ABSTRACT (continued)

with the parameter. Miscellaneous structural properties are established with applications to the quadratic regulator problem.

<b>Accession For</b>	
NTIS GRA&I	<input checked="" type="checkbox"/>
DTIC TAB	<input type="checkbox"/>
Unannounced	<input type="checkbox"/>
Justification	
By	
Distribution/	
Availability Codes	
Dist	Avail and/or Special
A	



UILU-80-2258

DESCRIPTOR VARIABLE AND GENERALIZED SINGULARLY  
PERTURBED SYSTEMS: A GEOMETRIC APPROACH

BY

J. Daniel Cobb

This work was supported in part by the U. S. Air Force under Grant AFOSR-78-3633, in part by the National Science Foundation under Grant NSF ECS-79-19396, and in part by the Joint Services Electronics Program under Contract N00014-79-C-0424.

Reproduction in whole or in part is permitted for any purpose of the United States Government.

Approved for public release. Distribution unlimited.

DESCRIPTOR VARIABLE AND GENERALIZED SINGULARLY  
PERTURBED SYSTEMS: A GEOMETRIC APPROACH

BY

J. DANIEL COBB

B.S., Illinois Institute of Technology, 1975  
M.S., University of Illinois, 1977

THESIS

Submitted in partial fulfillment of the requirements  
for the degree of Doctor of Philosophy in Electrical Engineering  
in the Graduate College of the  
University of Illinois at Urbana-Champaign, 1980

Thesis Adviser: Professor W. R. Perkins

Urbana, Illinois

DESCRIPTOR VARIABLE AND GENERALIZED SINGULARLY  
PERTURBED SYSTEMS: A GEOMETRIC APPROACH

J. Daniel Cobb, Ph.D.  
Department of Electrical Engineering  
University of Illinois at Urbana-Champaign, 1980

Existing results in descriptor variable theory are interpreted geometrically. New results are obtained concerning linear feedback and pole placement in such systems. Descriptor variable systems are viewed as limits of singularly perturbed systems. It is shown that some important singularly perturbed systems cannot be treated effectively with standard techniques. Hence, a generalized class of singularly perturbed systems is considered. A geometric decomposition that preserves continuity about the singular point is derived. Conditions are presented under which the solution of a singularly perturbed system converges with the parameter. Miscellaneous structural properties are established with applications to the quadratic regulator problem.



## ACKNOWLEDGMENT

The author would like to express his appreciation to Professors W. R. Perkins, J. B. Cruz, Jr., F. R. Albrecht, P. V. Kokotovic, and D. P. Looze for serving on his doctoral committee and especially to his advisor, Professor W. R. Perkins, for his invaluable help during the course of the research. Special thanks should also go to those fellow graduate students with which the author had many stimulating discussions, including Bill Hopkins, Boza Avramovic, and Doug Lindner. Finally, the author wishes to thank his parents for their support during his years of education.

## TABLE OF CONTENTS

CHAPTER	Page
1. INTRODUCTION .....	1
1.1. A Brief Overview of Descriptor Variable and Singular Perturbation Theory .....	1
1.2. Contributions of this Thesis .....	4
1.3. Chapter Survey .....	9
PART ONE: DESCRIPTOR VARIABLE THEORY .....	12
2. GEOMETRIC DECOMPOSITION .....	13
2.1. Problem Formulation .....	13
2.2. System Decomposition .....	15
2.3. Trajectories and Initial Conditions .....	21
3. CONTROLLABILITY AND POLE PLACEMENT .....	23
3.1. Reachability in the Fast Subspace .....	23
3.2. Controllability of Descriptor Variable Systems .....	26
3.3. The Effects of Linear Feedback .....	30
3.4. Slow Feedback .....	34
3.5. Fast Feedback .....	36
3.6. A Two-Stage Pole Placement Procedure .....	45
PART TWO: SINGULARLY PERTURBED SYSTEMS .....	46
4. DECCMPOSITION OF GENERALIZED SINGULARLY PERTURBED SYSTEMS .....	47
4.1. Preliminaries .....	47
4.2. Eigenvalue Behavior .....	55
4.3. Slow and Fast Subspaces .....	58
4.4. System Decomposition .....	60
5. TRAJECTORY CONVERGENCE .....	63
5.1. Solution of Descriptor Equations .....	63
5.2. Sufficient Conditions for Convergence .....	66
6. FURTHER STRUCTURAL PROPERTIES .....	78
6.1. Slow Subsystem .....	78
6.2. Fast Subsystem .....	81
6.3. Application to Pole Placement .....	83

## TABLE OF CONTENTS (continued)

	Page
7. THE LINEAR QUADRATIC REGULATOR .....	85
7.1. Preliminaries .....	85
7.2. Problem Formulation .....	86
7.3. Reduced-Order Solution at $\omega_0$ .....	88
7.4. Convergence of $\Lambda(\omega)$ .....	90
7.5. Convergence of the Optimal Solution .....	92
8. ALTERNATIVE FORMULATIONS AND CONCLUSIONS .....	94
8.1. Algebraic Interpretations .....	94
8.2. Geometry of the Space of Linear Systems .....	97
8.3. Suggestions for Further Research .....	99
8.4. Conclusions .....	100
REFERENCES .....	102
VITA .....	105

CHAPTER 1  
INTRODUCTION

1.1. A Brief Overview of Descriptor Variable and Singular  
Perturbation Theory

Descriptor variable theory depends heavily on the theory of regular matrix pencils which was first explored by Weierstrass in the nineteenth century [1]. A standard modern reference to the theory is Gantmacher [2]. A regular matrix pencil is a matrix polynomial  $Es-A$  where  $E$  and  $A$  are square matrices of the same dimensions and

$$\det(Es-A) \neq 0. \quad (1.1)$$

In (1.1) the determinant is formed in the obvious way by taking the determinant of the corresponding matrix of scalar polynomials.

More recently, it was observed by Rosenbrock [3],[4] that the linear system

$$E\dot{x} = Ax + Bu \quad (1.2)$$

is strongly related to the pencil  $Es-A$  since Laplace transformation of (1.2) yields

$$(Es-A)\hat{x} = B\hat{u} + Ex(0). \quad (1.3)$$

$\hat{x}$  and  $\hat{u}$  are the Laplace transforms of  $x$  and  $u$ . If  $E$  is singular, (1.2) is called a descriptor variable system.

In [4] Rosenbrock introduced his decomposition of (1.3) into static and dynamic parts along with the theory of infinite decoupling zeros. The decomposition uses the canonical form of a regular pencil to decompose the system into two parts, one whose eigenvalues are the same as those of (1.2)

and one with no dynamics in the usual sense. The theory of infinite decoupling zeros is an algebraic characterization of controllability and observability for the static subsystem. The theory utilizes properties of the pencil  $As-E$ . Continuing in the same direction, Verghese et al. [5]-[7] carried the work of Rosenbrock further with some modifications.

Proceeding in a somewhat different direction, Luenberger (who originally coined the phrase "descriptor variable") concerned himself with time varying, discrete-time descriptor systems. In [8] and [9], as well as having stated basic results, he gave many real-world examples as a justification of the development. [10] contains applications of the theory to the LQ regulator problem and to large-scale systems.

A third line of work has been followed by Campbell [11] who solved (1.2) using the Drazin inverse. The Drazin inverse is a generalized matrix inverse, closely related to the eigenspaces of a matrix. The solution of (1.2) can be written in terms of  $E$ ,  $A$ , and  $B$  and their Drazin inverses. Such an approach seems less traditional than that of the others insofar as it completely avoids explicit use of the theory of matrix pencils.

The motivation for descriptor variable theory for the most part is that, in choosing variables in a physical system in a natural way, one is not always guaranteed that the resulting mathematical model will be in state variable form. In many instances the most natural choice of system variables may be a non-minimal set leading to a system model (1.2) with  $E$  singular. Luenberger gives several examples of such systems in [8] and [9].

In other situations it may not even be possible to write a state equation under any choice of system variables. For example, Figure 1.1 shows a simple electrical network with one energy storage element. A convenient

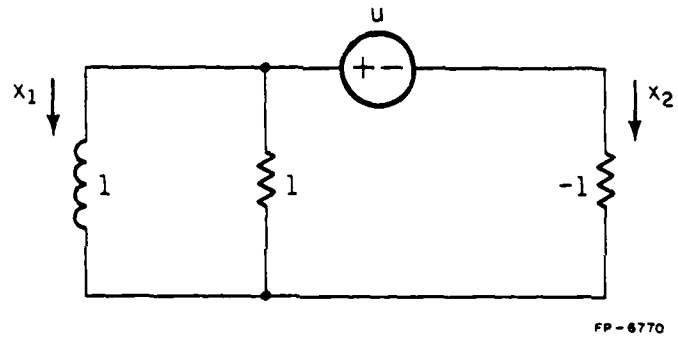

Figure 1.1. An electric circuit which is not naturally described by a state equation.

choice of variables might be as labeled. However, the loop equations are

$$\begin{aligned}\dot{x}_1 &= -x_1 - x_2 \\ 0 &= x_1 + u\end{aligned}\tag{1.4}$$

which cannot be manipulated into state space form. It will be shown in Chapter 2 that even though the circuit contains an energy storage element, the system order is zero. (1.4) is an almost trivial example of one sort of problem that can arise in system modeling. However, it is clear that in more complex situations when one's intuition may not be readily applied, a systematic approach to such problems is essential.

We now turn to singular perturbation theory. It is difficult to state precisely what constitutes a singular perturbation problem. Singularly perturbed systems are identified as such if they exhibit certain characteristic features. First, there is a dependence on a parameter of some sort, usually real and in some sense "small." Secondly, a slight change in the parameter results in a change in system order. This often occurs when a small real parameter multiplies a derivative of a system variable. Many times, when the parameter is set to give a low-order system, a descriptor variable system results. This fact is the basis for the relationship between descriptor variable and singularly perturbed systems.

Existing work in singular perturbation theory is extensive. Surveys of the subject include [12]-[14].

### 1.2. Contributions of this Thesis

In this section we shall explore some of the limitations of existing singular perturbation theory and general directions that will be taken in subsequent chapters to overcome them.

The majority of control oriented results in singular perturbation theory have been derived for the linear time-invariant system

$$\begin{aligned}\dot{x}_1 &= A_{11}x_1 + A_{12}x_2 + B_1u \\ \omega\dot{x}_2 &= A_{21}x_1 + A_{22}x_2 + B_2u\end{aligned}\tag{1.5}$$

where  $\omega$  is a small real parameter and  $A_{22}$  is nonsingular. There are, however, important cases in which system models yield singular  $A_{22}$ . A simple example is given in Figure 1.2. The system equations are

$$\begin{aligned}\dot{x}_1 &= -x_1 - x_2 \\ -\omega\dot{x}_2 &= x_1 + u.\end{aligned}\tag{1.6}$$

Here  $A_{22} = 0$  and the results of [15]-[17] are not applicable. There are only a few results available concerning singular  $A_{22}$  (see [20]).

There are many instances in which systems may not be conveniently modeled in the form (1.5) even if singularity of  $A_{22}$  is allowed. Consider the operational amplifier circuit of Figure 1.3. Assuming an ideal amplifier, the system equations are

$$\begin{aligned}\omega\dot{x}_1 + \dot{x}_2 &= -x_1 - u \\ \omega\dot{x}_2 &= -x_2.\end{aligned}\tag{1.7}$$

(1.7) seems to be the most natural (i.e. most intuitively meaningful) description of Figure 1.3. Yet it is not clear how to transform (1.7) into the form (1.5). One might try to diagonalize the matrix of coefficients of  $\dot{x}_1$  and  $\dot{x}_2$ , but this would lead to a similarity transformation which is singular at  $\omega = 0$ . Thus system equivalence between (1.7) and the transformed system would be lost at  $\omega = 0$ . Other attempts at standardizing the model must all lead to a loss of the natural interpretation inherent in (1.7) of the parameter and system variables.



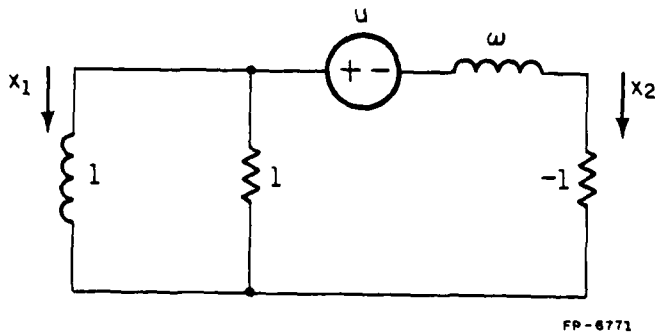

Figure 1.2. A singularly perturbed system with singular  $A_{22}$ .

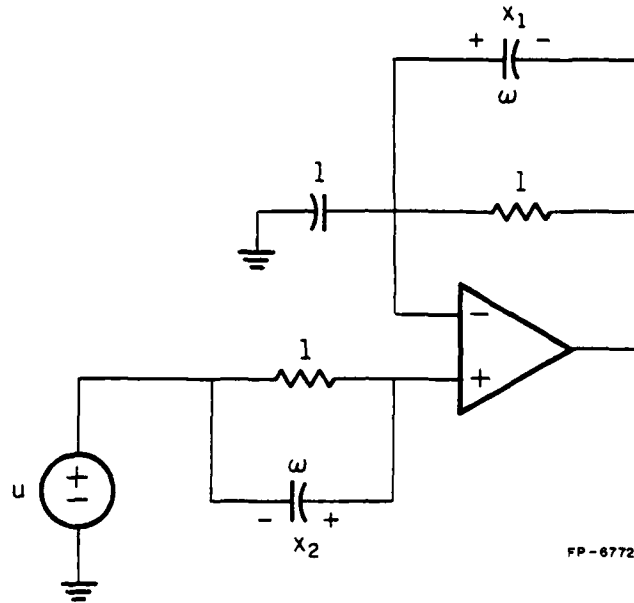

Figure 1.3. A singularly perturbed system which is not naturally representable by the standard form (1.5).

Actually, a more natural interpretation of the system of Figure 1.3 would include two parameters, one for each parasitic capacitance. This brings us to the problem of generalizing the system parameter. It is easy to think of many examples where the most intuitively pleasing model formulation requires several parameters. However, little work has been done in this area. Most results can be applied only to systems of a highly restrictive form [18],[19].

Singular perturbation theory is primarily a qualitative theory. Its purpose is to give insight into the nature of the perturbations of system related quantities that occur as a result of slight changes in system components. Quantitative results are scarce. In fact, the existence of practical numerical bounds on the variation of system related quantities would render most convergence results obsolete since bounds contain much more information than a simple statement of convergence. Singular perturbation theory is mainly a means of obtaining insight into the variational characteristics of a system and, in particular, of obtaining information about a high-order model by examining one of lower order.

Given a particular physical system it is clear that one may mathematically characterize it with a large number of parametrically dependent models. One task of those who apply the theory is that of choosing the model that supplies the most information. Since the information to be gained is basically qualitative, it makes the most sense to choose system parameters and variables which have direct and intuitively clear relationships with physical quantities in the system. It is true that singularly perturbed models of an extraordinary nature may in some cases be manipulated into something resembling a standard form. However, it is unavoidable that such

manipulations at times must diminish the intuitive power of the model resulting in a loss of information provided by the theory. It is for this reason that a more general theory is needed.

The main contributions of this work are 1) the reformulation of the singular perturbation problem to include system models which cannot be naturally put into a standard form, 2) the extension of existing control-theoretic results of standard singular perturbation theory to the more general class of system models, and 3) the unification of descriptor variable and singular perturbation theory for linear, time-invariant systems. It is hoped that this thesis will be viewed as a fresh look at the singular perturbation problem. Whenever possible, results are stated in coordinate-free or geometric terms. This is done in order to increase conceptual clarity. In this way the reader is freed from the burden of having to keep track of changes of coordinates which would appear in any discussion of structural properties and would necessarily depend on the perturbation parameter. The value of the geometric approach has been established by Wonham [21] and others. Part of the last chapter is devoted to alternative algebraic formulations of the problem. This is intended to give further insight into the nature of singularly perturbed systems.

It should be stressed here that even in the linear time-invariant case the structure of generalized singularly perturbed systems can be extremely complex. Many pertinent questions cannot be answered easily.

### 1.3. Chapter Survey

The thesis is divided into two main parts: ideas concerning descriptor variable theory (Chapters 2 and 3) and singular perturbation theory

(Chapters 4-7). In Chapter 2 the decomposition theory of Rosenbrock [4] is interpreted in geometric terms. It is shown that there is a natural decomposition of the state space into independent subspaces that span the whole space, including Rosenbrock's decomposition on the system. Chapter 3 carries the geometric approach further by defining controllability of descriptor systems and studying the interplay between controllability and linear non-dynamic feedback. The geometric structure of closed-loop systems is studied in the tradition of Wonham.

In Chapter 4 we begin the study of generalized singularly perturbed systems with the definition of such systems and with an extension of the geometric decomposition described in Chapter 2 to a region of the parameter space. Under this decomposition a singularly perturbed system consists of two subsystems which are consistent with the partitioning of the system eigenvalues into slow and fast modes. Chapter 5 is a study of the variation of the trajectory or solution of a system under small perturbations. Some conditions are given under which a small perturbation in system parameters results in a small change in the system trajectory. Chapter 6 is a study of the behavior of certain basic structural properties such as stability, controllability, and stabilizability that results from a perturbation of the system.

The linear quadratic regulator problem is considered in Chapter 7. Conditions are established under which the optimal control, trajectory, and cost change only slightly as a result of a small perturbation in system parameters. Finally, Chapter 8 contains some alternative ways of looking at

descriptor variable and singularly perturbed systems. Previous results are interpreted in new ways and basic conclusions of the thesis are stated.

PART ONE

DESCRIPTOR VARIABLE THEORY

## CHAPTER 2

## GEOMETRIC DECOMPOSITION

2.1. Problem Formulation

To facilitate the development in later chapters and to gain insight into the structure of descriptor systems we shall be concerned in this chapter with the decomposition of a given system into two subsystems. The decomposition has already been achieved in [4], for example, using analytic techniques. However, the geometric structure of the decomposition has not been described elsewhere. We shall parallel the development of the analytic decomposition for descriptor systems with geometric interpretations given at each step.

It will be seen that the natural response of one subsystem is a linear combination of the Dirac delta and its derivatives. Hence it will be called the "fast" subsystem. The other subsystem will be called "slow" since it is a state variable system with exponential natural response. It is emphasized that the terms slow and fast refer merely to the natural responses of the two subsystems of the original open loop system. The character of the trajectories of the two subsystems may change drastically when feedback or an external control is applied. The terms "dynamic" and "static" seem to be preferred by some authors. However, since we are ultimately concerned with singular perturbation theory, the terms slow and fast seem more appropriate.

Let  $X$  and  $U$  be complex Euclidean spaces with  $\dim X = n$  and  $\dim U = m$ .  $X$  and  $U$  have inner products and norms related by  $\langle x, x \rangle = \|x\|^2$  and  $\langle u, u \rangle = \|u\|^2$



for  $x \in X$ ,  $u \in U$ .<sup>1,2</sup> We shall consider only linear maps associated with  $X$  and  $U$ . Let  $\text{Hom}(U, X)$  be the  $C$ -vector space of homomorphisms from  $U$  into  $X$  where  $C$  is the complex plane. We choose to make the distinction between homomorphisms and matrices in keeping with the philosophy of coordinate-free representations.  $\text{Hom}(X, X)$  is the  $C$ -algebra of endomorphisms on  $X$ .  $\text{Hom}(X, X)$  has identity element  $I$ . If  $A \in \text{Hom}(X, X)$  and  $S$  is an  $A$ -invariant subspace of  $X$  then let  $A|_S \in \text{Hom}(S, S)$  be the restriction of  $A$  to  $S$ . The identity map in  $\text{Hom}(S, S)$  will also be denoted by  $I$ . If  $S$  is not  $A$ -invariant then  $A|_S \in \text{Hom}(S, X)$ .

Let  $A_i \in \text{Hom}(X, X)$ ,  $i=0, \dots, \nu$  and choose a basis  $\mathcal{B}$  of  $X$ . We denote by  $\det(A_\nu s^\nu + \dots + A_1 s + A_0)$  the determinant of the polynomial matrix  $[a_{ij}^\nu s^\nu + \dots + a_{ij}^1 s + a_{ij}^0]$  where  $\text{Mat}_{\mathcal{B}} A_k = [a_{ij}^k]$ .  $\det(A_\nu s^\nu + \dots + A_1 s + A_0)$  is independent of the particular choice of  $\mathcal{B}$ .

We shall consider dynamical systems described by differential equations of the form

$$A_\nu x^\nu + \dots + A_0 x = B_\pi u^\pi + \dots + B_0 u \quad (2.1)$$

where  $B_i \in \text{Hom}(U, X)$ ,  $i=0, \dots, \pi$  and superscripts denote differentiation with respect to  $t$ .  $A_i x^i$  and  $B_i u^i$  are to be interpreted in the obvious pointwise sense. The class of admissible controls is taken to be the set of all generalized functions (or distributions; see [24] and Section 5.1) with range in  $U$  that are identically zero on  $(-\infty, 0)$ . The admissible controls form a  $C$ -vector space denoted by  $\mathcal{D}_0(U)$ .

---

<sup>1</sup>Throughout the thesis all inner products are denoted by  $\langle \cdot, \cdot \rangle$ , and all norms by  $\| \cdot \|$ .

<sup>2</sup> $\langle \cdot, \cdot \rangle$  is conjugate symmetric.

The system equation (2.1) can be simplified considerably by defining  $Z = X^v \times U^\pi$ ,  $\mathcal{D}_0(X)$  and  $\mathcal{D}_0(Z)$  analogous to  $\mathcal{D}_0(U)$ , and  $z \in \mathcal{D}_0(Z)$ ,  $v \in \mathcal{D}_0(U)$  according to

$$z = (x, \dots, x^{v-1}, u, \dots, u^{\pi-1}) \quad (2.2)$$

and

$$v = u^\pi \quad (2.3)$$

where  $x$  is a solution of (2.1) for a given  $u$ . Then (2.1) may be rewritten

$$E\dot{z} = Az + Bv \quad (2.4)$$

where  $E, A \in \text{Hom}(Z, Z)$  and  $B \in \text{Hom}(U, Z)$ . Applying a control  $v$  to (2.4) corresponds to applying the  $\pi$ th indefinite integral of  $v$  to (2.1). Thus any problem involving (2.1) can be reduced to one in which (2.4) is considered.

Henceforth we shall concern ourselves with (2.4) only. Of course, the interesting case occurs when  $E$  is singular. We shall always assume that  $\det(Es-A) \neq 0$ .

## 2.2. System Decomposition

For simplicity, assume  $E, A \in \text{Hom}(X, X)$  and  $B \in \text{Hom}(U, X)$ . Our goal is to decompose the system

$$E\dot{x} = Ax + Bu \quad (2.5)$$

into slow and fast parts. Let  $\det(Es-A) = \phi_0 \prod_{i=1}^k (s-\lambda_i)^{n_i}$  where  $\phi_0 \neq 0$  and  $i \neq j$  implies  $\lambda_i \neq \lambda_j$ . Define  $\sigma(E, A) = \{\lambda_1, \dots, \lambda_k\}$  and let  $\lambda \in C - \sigma(E, A)$ . Then

$$\det(\lambda E - A) = \phi_0 \prod_{i=1}^k (\lambda - \lambda_i)^{n_i} \neq 0 \quad (2.6)$$

so  $\lambda E - A$  is invertible. Define

$$S = \bigoplus_{i=1}^k \text{Ker}((\lambda E - A)^{-1} E - \frac{1}{\lambda - \lambda_i} I)^{n_i} \quad (2.7)$$

and

$$F = \text{Ker}((\lambda E - A)^{-1} E)^{n-r} \quad (2.8)$$

where

$$r = \sum_{i=1}^k n_i = \text{deg}(\det(ES - A)) \leq n. \quad (2.9)$$

Clearly,  $r \leq \text{rank } E$  with  $r = n$  if and only if  $E$  is invertible.

Theorem 2.1 gives a canonical decomposition of  $X$  with respect to the pair  $(E, A)$ .

Theorem 2.1: 1.  $S \oplus F = X$  with  $\dim S = r$ .

2. There exists an invertible  $M \in \text{Hom}(X, X)$  such that

- a)  $S$  and  $F$  are both  $ME$ - and  $MA$ -invariant
- b)  $ME|_S = I$ ,  $MA|_F = I$
- c)  $ME|_F$  is nilpotent
- d)  $\det(Is - MA|_S) = \prod_{i=1}^k (s - \lambda_i)^{n_i}$ .

Proof:<sup>3</sup> Let  $\det(Is - (\lambda E - A)^{-1} E) = s^{n-d} \prod_{i=1}^{\delta} (s - \eta_i)^{m_i}$  where  $d = \sum_{i=1}^{\delta} m_i$ ,  $\eta_i \neq 0$  for  $i=1, \dots, \delta$ , and  $i \neq j$  implies  $\eta_i \neq \eta_j$ .<sup>4</sup>  $n-d$  is the multiplicity of the zero eigenvalue of  $(\lambda E - A)^{-1} E$ . Define

$$R_1 = \bigoplus_{i=1}^{\delta} \text{Ker}((\lambda E - A)^{-1} E - \eta_i I)^{m_i}$$

and

$$R_2 = \text{Ker}((\lambda E - A)^{-1} E)^{n-d}.$$

Then  $R_1 \oplus R_2 = X$ ,  $\dim R_1 = d$ , and  $R_1$  and  $R_2$  are both  $(\lambda E - A)^{-1} E$ -invariant.

<sup>3</sup>Much of this proof was patterned after Gantmacher [2], Vol. 1, p. 28.

<sup>4</sup> $\eta_i$  clearly depends on  $\lambda$ . However,  $\lambda$  is fixed so we do not write this dependence explicitly as  $\eta_i(\lambda)$ .

Let  $J_1 = (\lambda E - A)^{-1} E|_{R_1}$  and  $J_2 = (\lambda E - A)^{-1} E|_{R_2}$ . Then  $\det(Is - J_1) = \prod_{i=1}^{\delta} (s - \eta_i)^{m_i}$  and  $J_2$  is nilpotent. Since  $(\lambda E - A)^{-1} A = \lambda(\lambda E - A)^{-1} E - I$ ,  $(\lambda E - A)^{-1} A|_{R_1} = \lambda J_1 - I$  and  $(\lambda E - A)^{-1} A|_{R_2} = \lambda J_2 - I$ . Define  $\bar{M} \in \text{Hom}(X, X)$  according to

$$\bar{M}x = \begin{cases} J_1^{-1}x & \text{if } x \in R_1 \\ (\lambda J_2 - I)^{-1}x & \text{if } x \in R_2 \end{cases}.$$

$J_1$  and  $\lambda J_2 - I$  are invertible since  $J_1$  has no zero eigenvalues and  $J_2$  is nilpotent. Let  $M = \bar{M}(\lambda E - A)^{-1}$ . Then  $R_1$  and  $R_2$  are both  $ME$ - and  $MA$ -invariant with

$$ME|_{R_1} = \bar{M}(\lambda E - A)^{-1} E|_{R_1} = J_1^{-1} J_1 = I$$

and

$$MA|_{R_2} = \bar{M}(\lambda E - A)^{-1} A|_{R_2} = (\lambda J_2 - I)^{-1} (\lambda J_2 - I) = I.$$

Also,

$$ME|_{R_2} = (\lambda J_2 - I)^{-1} J_2$$

which is nilpotent and

$$MA|_{R_1} = J_1^{-1} (\lambda J_1 - I) = \lambda I - J_1^{-1}.$$

Next observe that

$$\begin{aligned} \det(Es - A) &= \frac{\det(MEs - MA)}{\det M} \\ &= \frac{\det(Is - MA|_{R_1}) \det(ME|_{R_2} s - I)}{\det M}. \end{aligned}$$

But  $\det(ME|_{R_2} s - I) = (-1)^{n-d}$  so  $\det(Is - MA|_{R_1}) = \prod_{i=1}^k (s - d_i)^{n_i}$ . Also

$$\det(Is - MA|_{R_1}) = (Is - (\lambda I - J_1^{-1})) = \prod_{i=1}^{\delta} (s - (\lambda - \frac{1}{\eta_i}))^{m_i}.$$

Thus, if the  $\eta_i$  are indexed properly, we have  $\delta = k$ ,  $m_i = n_i$ ,  $d = r$ , and  $\lambda - \frac{1}{\eta_i} = \lambda_i$  so  $\eta_i = \frac{1}{\lambda - \lambda_i}$ . Hence  $R_1 = S$ ,  $R_2 = F$ . This completes the proof.

The construction of  $M$  in the preceding theorem is important so it will be repeated here. Let

$$J_1 = (\lambda E - A)^{-1} E|S \quad (2.10)$$

$$J_2 = (\lambda E - A)^{-1} E|F \quad (2.11)$$

and let  $\bar{M} \in \text{Hom}(X, X)$  be defined by

$$\bar{M}x = \begin{cases} J_1^{-1}x & \text{if } x \in S \\ (\lambda J_2 - I)^{-1}x & \text{if } x \in F \end{cases} \quad (2.12)$$

Finally, let

$$M = \bar{M}(\lambda E - A)^{-1} \quad (2.13)$$

$$L_f = ME|F, \quad L_s = MA|S. \quad (2.14)$$

Note that

$$\text{rank } L_f = \text{rank } ME - r = \text{rank } E - r. \quad (2.15)$$

Formulas (2.7), (2.8), and (2.10)-(2.14) constitute a family of algorithms for decomposing the pair  $(E, A)$ . The family is indexed by the parameter  $\lambda$  which ranges over  $C - \sigma(E, A)$ . It is fortunate that all the algorithms give the same end result. The following two lemmas establish that  $S$ ,  $F$ ,  $M$ , and consequently  $L_s$  and  $L_f$  are independent of  $\lambda$ .

**Lemma 2.1:** Let  $\lambda_i \in \sigma(E, A)$ ,  $\beta$  be any positive integer, and  $L_s$  and  $L_f$  be generated by using a fixed parameter  $\lambda \in C$  in the algorithm (2.7)-(2.14). Then

$$1) \quad \text{Ker}((\eta E - A)^{-1} E - \frac{1}{\eta - \lambda_i} I)^\beta = \text{Ker}(\lambda_i I - L_s)^\beta$$

and

$$2) \quad \text{Ker}((\eta E - A)^{-1} E)^\beta = \text{Ker } L_f^\beta$$

for all  $\eta \in C - \sigma(E, A)$ .

Proof: 1) First observe that

$$(\eta E - A)^{-1} E - \frac{1}{\eta - \lambda_i} I = - \frac{1}{\eta - \lambda_i} (\eta E - A)^{-1} (\lambda_i E - A)$$

so if  $M$  is given by (2.7)-(2.13) (using  $\lambda$ , not  $\eta$ ) we have

$$\begin{aligned} \text{Ker}((\eta E - A)^{-1} E - \frac{1}{\eta - \lambda_i} I)^\beta &= \text{Ker}((\eta E - A)^{-1} (\lambda_i E - A))^\beta \\ &= \text{Ker}((\eta E - A)^{-1} M^{-1} M (\lambda_i E - A))^\beta \\ &= \text{Ker}((\eta M E - M A)^{-1} (\lambda_i M E - M A))^\beta \\ &= \text{Ker}((\eta I - L_s)^{-1} (\lambda_i I - L_s))^\beta \\ &\quad \oplus \text{Ker}((\eta L_f - I)^{-1} (\lambda_i L_f - I))^\beta \\ &= \text{Ker}((\eta I - L_s)^{-1} (\lambda_i I - L_s))^\beta \end{aligned}$$

since  $\lambda_i L_f - I$  is invertible. Also

$$((\eta I - L_s)^{-1} (\lambda_i I - L_s))^\beta = (\eta I - L_s)^{-\beta} (\lambda_i I - L_s)^\beta$$

since  $(\eta I - L_s)^{-1}$  and  $\lambda_i I - L_s$  commute. Hence

$$\text{Ker}((\eta E - A)^{-1} E - \frac{1}{\eta - \lambda_i} I)^\beta = \text{Ker}(\lambda_i I - L_s)^\beta.$$

2) The argument parallels that of part 1).

$$\begin{aligned} \text{Ker}((\eta E - A)^{-1} E)^\beta &= \text{Ker}((\eta M E - M A)^{-1} M E)^\beta \\ &= \text{Ker}(\eta I - L_s)^{-\beta} \oplus \text{Ker}((\eta L_f - I)^{-1} L_f)^\beta \\ &= \text{Ker } L_f^\beta \end{aligned}$$

since  $(\eta L_f - I)^{-1}$  and  $L_f$  commute. This completes the proof.

An obvious corollary to Lemma 2.1 is that  $S$  and  $F$  do not depend on  $\lambda$ . The  $\lambda$ -independence of  $M$  will be shown next.

Lemma 2.2: Let  $J_1(\lambda)$ ,  $J_2(\lambda)$ ,  $\bar{M}(\lambda)$ , and  $M(\lambda)$  be given by (2.10)-(2.13) for some choice of  $\lambda$ . For  $\eta \in C - \sigma(E, A)$  define  $J_1(\eta)$ ,  $J_2(\eta)$ ,  $\bar{M}(\eta)$ , and  $M(\eta)$  in the obvious way. Then  $M(\eta) = M(\lambda)$  regardless of the choice of  $\eta$ .

Proof: We have

$$M(\lambda)E|S = I, \quad M(\lambda)A|F = I.$$

Define

$$L_s(\lambda) = M(\lambda)A|S, \quad L_f(\lambda) = M(\lambda)E|F.$$

Then

$$\begin{aligned} J_1(\eta) &= (\eta M(\lambda)E - M(\lambda)A)^{-1} M(\lambda)E|S \\ &= (\eta I - L_s(\lambda))^{-1}. \end{aligned}$$

Similarly,

$$J_2(\eta) = (\eta L_f(\lambda) - I)^{-1} L_f(\lambda)$$

so

$$\bar{M}(\eta)|S = \eta I - L_s(\lambda)$$

and

$$\bar{M}(\eta)|F = \eta L_f(\lambda) - I.$$

Hence

$$\bar{M}(\eta)(\eta M(\lambda)E - M(\lambda)A)^{-1} = I$$

so

$$\begin{aligned} M(\eta) &= \bar{M}(\eta)(\eta M(\lambda)E - M(\lambda)A)^{-1} M(\lambda) \\ &= M(\lambda) \end{aligned}$$

which is the desired result.

This brings us to the decomposition of the descriptor system (2.5).

Operating on both sides of (2.5) by  $M$  yields

$$ME\dot{x} = MAx + MBu. \tag{2.16}$$

Define  $P \in \text{Hom}(X, S)$  and  $Q \in \text{Hom}(X, F)$  as the skew projection operators on  $S$  along  $r$  and on  $F$  along  $S$  respectively. Let

$$B_s = PMB \quad (2.17)$$

and

$$B_f = QMB. \quad (2.18)$$

We may rewrite (2.16) as

$$\dot{x}_s = L_s x_s + B_s u \quad (2.19)$$

$$L_f \dot{x}_f = x_f + B_f u \quad (2.20)$$

where

$$x_s = Px \quad \text{and} \quad x_f = Qx.$$

We now have two systems acting on independent state spaces with  $x = x_s + x_f$ .

### 2.3. Trajectories and Initial Conditions

If  $T \in \text{Hom}(S, S)$  define  $e(T) : [0, \infty) \rightarrow \text{Hom}(S, S)$  according to

$$e(T)(t) = e^{tT}. \quad (2.21)$$

Then the solution of (2.19) is simply

$$x_s = e(L_s)Px_0 + e(L_s)*B_s u \quad (2.22)$$

where "\*" denotes convolution. Defining solutions of (2.20) is a more complicated task.

Let  $q$  be the index of nilpotency of  $L_f$ . In [11] Campbell showed that for each  $q$  times differentiable  $u : [0, \infty) \rightarrow U$  there exists a unique differentiable  $x_f : [0, \infty) \rightarrow F$  satisfying (2.20).  $x_f$  is given by

$$x_f(t) = -\sum_{i=0}^{q-1} L_f^i B_f u^{(i)}(t). \quad (2.23)$$

Note that no initial condition is specified. This is in contrast to the family of solutions of (2.19), a particular solution being singled out by choosing an initial condition  $x_{s0} \in S$ .



It has been suggested in [5] and [7] that by allowing solutions of (2.20) from  $\mathcal{D}_0(X)$ , a distinct solution may be defined for each choice of initial condition  $x_{f0} \in F$ . The proposed solution is

$$x_f = - \sum_{i=1}^{q-1} \delta^{i-1} L_f^i x_{f0} - \sum_{i=0}^{q-1} L_f^i B_f u^i \quad (2.24)$$

where  $\delta^j$  is the  $j$ th derivative of the Dirac delta. (2.24) was obtained by taking the Laplace transform of (2.20). Although the Laplace transform approach is quite formal and is not very satisfying intuitively, we shall take (2.24) to be the solution of (2.20). A more intuitively pleasing justification will be given in Chapter 5. We shall see that, for any singularly perturbed system with (2.20) as its limiting descriptor form, if its solutions converge to anything then they converge to (2.24).

The parts of (2.22) and (2.24) due to initial conditions alone serve as motivation for calling (2.19) the slow subsystem and (2.20) the fast subsystem. Also, we shall henceforth call  $S$  the slow subspace and  $F$  the fast subspace.

## CHAPTER 3

## CONTROLLABILITY AND POLE PLACEMENT

3.1. Reachability in the Fast Subspace

In this chapter we begin by defining controllability for descriptor systems. Although the idea of extending the usual state variable definition of controllability to descriptor systems is a fairly obvious generalization, it has not been proposed elsewhere.

Some authors have come close to considering controllability. Rosenbrock in his theory of infinite decoupling zeros [4] considered certain properties of descriptor variable systems which are related to controllability. According to his definitions, a descriptor system has infinite decoupling zeros if and only if the matrix  $[sA-E \ ; \ B]$  loses rank at  $s=0$ . It will be shown that this condition is equivalent to uncontrollability of the fast subsystem as we shall define it in Definition 3.1. Rosenbrock's theory, however, does not address the problems of state reachability and of finding controls that steer the trajectory to a specified state.

In [10] Luenberger et al. defined the concept of maintainability which is also related to controllability as we shall define it. Maintainability guarantees that a solution exists to a certain type of tracking problem determined by the parameters of a descriptor system. It is clear after examination of the definitions that maintainability is not equivalent to our forthcoming definition of controllability. For our purposes it will be convenient to define controllability for descriptor systems in a way more closely analogous to the standard definition of controllability for state variable systems.

In generalized function theory it is often impossible to talk about the value of a function at a given point.<sup>1</sup> To avoid this problem let  $C^q(U)$  be the C-vector space of  $q$  times continuously differentiable mappings from  $[0, \infty)$  into  $U$  (using the right-hand derivative at 0) and consider only controls from  $C^q(U)$ . Then  $x_f$  may be identified with a differentiable ordinary function on  $(0, \infty)$ , namely

$$x_f = - \sum_{i=0}^{q-1} L_f^i B_f u^i, \quad t > 0 \quad (3.1)$$

and it makes sense to say

$$x_f(t) = - \sum_{i=0}^{q-1} L_f^i B_f u^i(t) \quad (3.2)$$

for any  $t > 0$ .

The definition of a reachable vector for descriptor variable systems is highly analogous to that of a reachable state for state variable systems. Let  $\phi : [0, \infty) \times C^q(U) \times X \rightarrow X$  be given by

$$\phi(t, u, x_0) = e^{tL_s}(P x_0) + \int_0^t e^{(t-\tau)L_s} B_s u(\tau) d\tau - \sum_{i=0}^{q-1} L_f^i B_f u^i(t) \quad (3.3)$$

where  $u^i(0)$  is the  $i$ th right-hand derivative at 0. Then  $\phi(\cdot, u, x_0)$  agrees on  $(0, \infty)$  with the solution of (2.5) with control  $u$  and initial condition  $x_0$ .

**Definition 3.1:** A vector  $w \in X$  is said to be reachable from  $x_0 \in X$  with respect to the system (2.5) at time  $\tau \in (0, \infty)$  if there exists a control  $u \in C^q(U)$  such that  $\phi(\tau, u, x_0) = w$ .

Clearly, when applied to the slow subsystem (2.19), Definition 3.1 is equivalent to the usual notion of controllability from state variable theory.

---

<sup>1</sup>What is  $\delta(0)$ ?

We now consider controllability of the fast subsystem (2.20). Let

$$\mathcal{R}_f = \text{Im}B_f + L_f \text{Im}B_f + \dots + L_f^{q-1} \text{Im}B_f. \quad (3.4)$$

Theorem 3.1: Let  $w \in F$ . The following statements are equivalent with regard to the fast subsystem (2.20):

- 1)  $w \in \mathcal{R}_f$ .
- 2) There exist  $\tau \in (0, \infty)$  and  $x_{fo} \in F$  such that  $w$  is reachable from  $x_{fo}$  at time  $\tau$ .
- 3)  $w$  is reachable from  $x_{fo}$  at time  $\tau$  for every  $\tau \in (0, \infty)$ ,  $x_{fo} \in F$ .

Proof: It should be noted at the outset that the initial vector  $x_{fo}$  has no effect on the solution of (2.20) for  $t > 0$ . It appears in statements 2) and 3) merely to preserve the form of the analogous theorem from state variable theory.

First we show that 1) implies 3). Let  $x_{fo} \in F$  and  $\tau \in (0, \infty)$  be given. Since  $w \in \mathcal{R}_f$ ,  $w = w_0 + \dots + w_{q-1}$  with  $w_i \in L_f^i \text{Im}B_f$ ,  $i = 0, \dots, q-1$ . Since  $L_f^i \text{Im}B_f = \text{Im}(L_f^i B_f)$ , there are  $u_i \in U$  satisfying  $L_f^i B_f u_i = -w_i$ ,  $i = 0, \dots, q-1$ . Define  $u \in C^q(U)$  according to

$$u(t) = u_0 + (t-\tau)u_1 + \frac{(t-\tau)^2}{2!} u_2 + \dots + \frac{(t-\tau)^{q-1}}{(q-1)!} u_{q-1}.$$

Then

$$\begin{aligned} \phi(\tau, u, x_{fo}) &= -\sum_{i=0}^{q-1} L_f^i B_f u_i(\tau) \\ &= -\sum_{i=0}^{q-1} L_f^i B_f u_i \\ &= w. \end{aligned}$$

Obviously, 3) implies 2) so it remains to show that 2) implies 1).

This follows almost trivially since  $L_f^i B_f u_i(\tau) \in L_f^i \text{Im}B_f$ . Inspection of the definitions of  $\phi$  and  $\mathcal{R}_f$  gives the desired result.

### 3.2. Controllability of Descriptor Variable Systems

We now consider reachability and define controllability for descriptor systems. Let  $\mathcal{R}_s$  be the controllable subspace<sup>2</sup> of the slow subsystem (2.19).

Lemma 3.1: Let  $p$  be a nonnegative integer,  $\tau \in (0, \infty)$ , and

$$\mathcal{N}_{\tau p} = \int_0^{\tau} t^{2p} e^{tL_s} B_s B_s^* e^{tL_s^*} dt. \quad 3$$

Then

$$\text{Im } \mathcal{N}_{\tau p} = \mathcal{R}_s.$$

Proof:<sup>4</sup> Let  $x \in \text{Ker } \mathcal{N}_{\tau p}$  for some  $\tau, p$ . Then

$$\begin{aligned} \int_0^{\tau} \| t^p B_s^* e^{tL_s^*} x \|^2 dt &= \int_0^{\tau} \langle x, t^{2p} e^{tL_s} B_s B_s^* e^{tL_s^*} x \rangle dt \\ &= \langle x, \int_0^{\tau} t^{2p} e^{tL_s} B_s B_s^* e^{tL_s^*} x dt \rangle \\ &= \langle x, \mathcal{N}_{\tau p} x \rangle \\ &= 0 \end{aligned}$$

so  $t^p B_s^* e^{tL_s^*} x = 0$  for all  $t \in [0, \tau]$ . Right-hand differentiation  $p+r-1$  times at  $t=0$  gives

$$B_s^* L_s^{*i} x = 0, \quad i=0, \dots, r-1. \quad (3.5)$$

Hence

$$\begin{aligned} x \in \bigcap_{i=0}^{r-1} \text{Ker}(B_s^* L_s^{*i}) &= \bigcap_{i=0}^{r-1} \text{Im}(L_s^i B_s)^{\perp} \\ &= \left( \sum_{i=0}^{r-1} \text{Im}(L_s^i B_s) \right)^{\perp} \\ &= \mathcal{R}_s \end{aligned} \quad (3.6)$$

<sup>2</sup>See [21].

<sup>3</sup>\*denotes the adjoint operator.

<sup>4</sup>This is an adaptation of a proof given on pp. 35-36 of [21].

so  $\text{Ker } \mathcal{N}_{\tau p} \subset \mathcal{R}_S^\perp$  and

$$\mathcal{R}_S \subset \text{Ker } \mathcal{N}_{\tau p}^\perp = \text{Im } \mathcal{N}_{\tau p}^* = \text{Im } \mathcal{N}_{\tau p}$$

since  $\mathcal{N}_{\tau p}$  is Hermitian.

To show the reverse inclusion let  $x \in \mathcal{R}_S^\perp$ . Then (3.6) holds and hence (3.5) does also. Recall that there exist  $\gamma_i : [0, \tau] \rightarrow \mathbb{C}$ ,  $i=0, \dots, r-1$  such that

$$e^{tL_S} = \gamma_0(t)I + \gamma_1(t)L_S + \dots + \gamma_{r-1}(t)L_S^{r-1}$$

for all  $t \in [0, \tau]$ . Thus

$$t^p B_S^* e^{tL_S} x = \sum_{i=0}^{r-1} t^p \gamma_i(t) B_S^* L_S^{i+1} x = 0$$

and  $\mathcal{N}_{\tau p} x = 0$  so

$$x \in \text{Im } \mathcal{N}_{\tau p}^\perp = \text{Ker } \mathcal{N}_{\tau p}.$$

Hence  $\mathcal{R}_S^\perp \subset \text{Ker } \mathcal{N}_{\tau p}$  and  $\text{Im } \mathcal{N}_{\tau p} \subset \mathcal{R}_S$ . This completes the proof.

Let  $\mathcal{R} = \mathcal{R}_S \oplus \mathcal{R}_f$ . The next result justifies calling  $\mathcal{R}$  the controllable subspace.

Theorem 3.2: Let  $w \in X$ . The following statements are equivalent with regard to the system (2.5):

- 1)  $w \in \mathcal{R}$ .
- 2) There exists  $\tau \in (0, \infty)$  and  $x_0 \in \mathcal{R}_S \oplus F$  such that  $w$  is reachable from  $x_0$  at time  $\tau$ .
- 3)  $w$  is reachable from  $x_0$  at time  $\tau$  for every  $\tau \in (0, \infty)$ ,  $x_0 \in \mathcal{R}_S \oplus F$ .

Proof: To show 1) implies 3) let  $\tau$  and  $x_0$  be given and let  $w = w_S + w_f$ ,  $w_S \in \mathcal{R}_S$ ,  $w_f \in \mathcal{R}_f$ . Choose  $u_i$ ,  $i=0, \dots, q-1$  so that

$$-\sum_{i=0}^{q-1} L_f^i B_f u_i = w_f$$

and define  $u_f \in C^q(U)$  by

$$u_f(t) = u_0 + (t-\tau)u_1 + \frac{(t-\tau)^2}{2!}u_2 + \dots + \frac{(t-\tau)^{q-1}}{(q-1)!}u_{q-1}.$$

Let

$$\phi = \int_0^\tau e^{(\tau-t)L_S} B_S u_f(t) dt \in \mathcal{R}_S$$

and choose any position integer  $p > \frac{q-1}{2}$ . Let  $x_0 = x_{s0} + x_{f0}$ ,  $x_{s0} \in \mathcal{R}_S$ ,  $x_{f0} \in F$ .

Since  $\mathcal{R}_S$  is  $L_S$ -invariant,  $w_s - e^{\tau L_S} x_{s0} - \phi \in \mathcal{R}_S$  and from Lemma 3.1 there exists  $z \in S$  with

$$\mathcal{N}_{\tau p} z = w_s - e^{\tau L_S} x_{s0} - \phi.$$

Define

$$u(t) = (\tau-t)^{2p} B_S^* e^{(\tau-t)L_S^*} z + u_f(t).$$

Then  $u^i(\tau) = u_f^i(\tau) = u_i$ ,  $i = 0, \dots, q-1$  and

$$-\sum_{i=0}^{q-1} L_f^i B_f u^i(\tau) = w_f.$$

Also

$$\begin{aligned} \int_0^\tau e^{(\tau-t)L_S} B_S u(t) dt &= \int_0^\tau (\tau-t)^{2p} e^{(\tau-t)L_S} B_S B_S^* e^{(\tau-t)L_S^*} z dt + \phi \\ &= \mathcal{N}_{\tau p} z + \phi \end{aligned}$$

and hence

$$\phi(\tau, u, x_0) = w_s + w_f = w.$$

2) follows from 3) trivially. Inspection of the definition of  $\phi$  gives that 2) implies 1) and the proof is complete.

For obvious reasons, if  $\mathcal{R} = X$  the system (2.5) is said to be completely controllable and  $(E, A, B)$  is called a controllable triple.

Implicit in the notation  $(E, A, B)$  is the assumption that  $\det(Es - A) \neq 0$ .

Recall that an eigenvalue  $\lambda_i$  of  $L_s$  is called a controllable mode if the eigenspace of  $\lambda_i$  is reachable, i.e.

$$\text{Ker}(\lambda_i I - L_s)^{n_i} \subset \mathcal{R}_s. \quad (3.7)$$

In [3] and [5] tests were established to check for the existence of input decoupling zeros. Although they were not originally intended to pertain to our concept of controllability, these tests are related to our definitions. We shall interpret them geometrically.

Theorem 3.3: 1) An eigenvalue  $\lambda_i \in \sigma(E, A)$  is a controllable mode of the slow subsystem (2.19) if and only if

$$\text{Im}(\lambda_i E - A) + \text{Im}B = X.$$

2) The fast subsystem (2.20) is completely controllable if and only if

$$\text{Im}E + \text{Im}B = X.$$

Proof: 1) Let  $M$  be given by (2.13). Then

$$\begin{aligned} M(\text{Im}(\lambda_i E - A) + \text{Im}B) &= \text{Im}(\lambda_i ME - MA) + \text{Im}(MB) \\ &= \text{Im}(\lambda_i I - L_s) + \text{Im}(\lambda_i L_f - I) + \text{Im}(MB) \\ &= (\text{Im}(\lambda_i I - L_s) + \text{Im}B_s) \oplus F \end{aligned}$$

since  $\lambda_i L_f - I$  is invertible. From state variable theory,

$$\text{Im}(\lambda_i I - L_s) + \text{Im}B_s = S$$

if and only if  $\lambda_i$  is a controllable mode. Since  $M$  is invertible the result follows.

2) From (3.4) it follows that the fast subsystem is completely controllable if and only if  $(L_f, B_f)$  is a controllable pair or equivalently,

$$\text{Im}(\lambda I - L_f) + \text{Im}B_f = F$$



for all  $\lambda \in \mathbb{C}$ . This certainly holds for  $\lambda \neq 0$ . Hence

$$\begin{aligned} M(\text{Im}E + \text{Im}B) &= \text{Im}(ME) + \text{Im}(MB) \\ &= S \oplus (\text{Im}L_f + \text{Im}B_f) \end{aligned}$$

gives the desired result.

### 3.3. The Effects of Linear Feedback

Now that controllability has been defined, we can investigate its bearing on problems associated with descriptor systems. As we shall see, in some situations it is necessary to allow controls in  $\mathcal{D}_0(U) - C^q(U)$ . At first it may seem strange that controllability is a useful concept in such cases since it was defined entirely in terms of  $C^q(U)$  controls. However, closer inspection reveals that controllability is essentially a structural property independent of the types of control driving the system.

Suppose one were to apply to the system (2.5) a feedback control law

$$u(t) = Kx(t) + v(t) \quad (3.8)$$

where  $K \in \text{Hom}(X, U)$  and  $v \in \mathcal{D}_0(U)$ . The system would then be of the form

$$E\dot{x} = (A + BK)x + Bv. \quad (3.9)$$

However, it is easy to construct examples where the condition

$$\det(Es - A - BK) \neq 0 \quad (3.10)$$

is violated. Since we do not know how to deal with such systems theoretically, only those  $K$  satisfying (3.10) will be considered.

Our first task is to establish relationships between the structures of the open and closed loop systems (2.5) and (3.9). One easy result concerns systems satisfying

$$\text{rank } E = r \quad (3.11)$$

where  $r$  is defined in (2.9). (2.15) shows that (3.11) is equivalent to  $L_f = 0$ . If (3.11) holds then

$$\dim(\text{Ker } E) = n - r = \dim F. \quad (3.12)$$

From (2.8), the definition of  $F$ ,  $\text{Ker } E \subset F$ . Hence (3.11) implies  $F = \text{Ker } E$  so the fast subspace of any system satisfying (3.11) is invariant to linear feedback.

A more difficult result says that the feedback invariance of the controllable subspace in state variable theory can be extended to descriptor systems. To prove this we shall need a lemma.

Lemma 3.2: Let  $(E, A, B)$  have controllable subspace  $\mathcal{R}$ . Then the pair  $((\lambda E - A)^{-1}E, (\lambda E - A)^{-1}B)$  has controllable subspace  $\mathcal{R}$  (in the state variable sense) for any  $\lambda \in \mathbb{C} - \sigma(E, A)$ .

Proof: Choose  $\lambda \notin \sigma(E, A)$  and observe that

$$R + (\lambda I - L_S)R \subset R + L_S R$$

for any subspace  $R$  of  $S$ . If  $x \in R + L_S R$  then there exist  $y, z \in R$  such that  $x = y + L_S z$ . Let  $\bar{z} = -z$  and  $\bar{y} = y + \lambda z$ . Then  $\bar{z}, \bar{y} \in R$  and

$$x = \bar{y} + (\lambda I - L_S)\bar{z} \in R + (\lambda I - L_S)R$$

so

$$R + L_S R = R + (\lambda I - L_S)R.$$

Assume that

$$R + L_S R + \cdots + L_S^k R = R + (\lambda I - L_S)R + \cdots + (\lambda I - L_S)^k R$$

for some  $k$ . Then

$$\begin{aligned}
R + L_S R + \cdots + L_S^{k+1} R &= R + L_S R + \cdots + L_S^k R \\
&\quad + L_S (R + L_S R + \cdots + L_S^k R) \\
&= R + L_S R + \cdots + L_S^k R \\
&\quad + (\lambda I - L_S) (R + L_S R + \cdots + L_S^k R) \\
&= (\lambda I - L_S) R + \cdots + (\lambda I - L_S)^{k+1} R.
\end{aligned}$$

Setting  $R = \text{Im}B_S$ , it follows that

$$\mathcal{R}_S = \text{Im}B_S + (\lambda I - L_S) \text{Im}B_S + \cdots + (\lambda I - L_S)^{n-1} \text{Im}B_S.$$

Since  $\mathcal{R}_S$  is  $L_S$ -invariant it is also  $(\lambda I - L_S)^{-1}$ -invariant so

$$\mathcal{R}_S = (\lambda I - L_S)^{-1} \text{Im}B_S + \cdots + (\lambda I - L_S)^{-n} \text{Im}B_S.$$

We shall now prove that

$$\begin{aligned}
\mathcal{R}_f &= (\lambda L_f - I)^{-1} \text{Im}B_f + ((\lambda L_f - I)^{-1} L_f) (\lambda L_f - I)^{-1} \text{Im}B_f + \cdots + \\
&\quad + \cdots + ((\lambda L_f - I)^{-1} L_f)^{n-1} (\lambda L_f - I)^{-1} \text{Im}B_f.
\end{aligned}$$

For  $\lambda = 0$  this is obvious so assume that  $\lambda \neq 0$  and let  $R$  be any subspace of  $F$ .

Clearly,

$$L_f^{n-1} R + (\lambda L_f - I) L_f^{n-2} R + (\lambda L_f - I)^2 L_f^{n-3} R + \cdots + (\lambda L_f - I)^{n-1} R \subset R + L_f R + \cdots + L_f^{n-1} R.$$

Let  $0 \leq k \leq n-1$  and consider the  $n \times n$  matrix  $T = [t_{ij}]$  where

$$t_{ij} = \begin{cases} \binom{i}{i-j} (-1)^j \lambda^{i-j} & \text{if } i \geq j \\ 0 & \text{if } i < j \end{cases}.$$

$T$  is invertible so there exist  $\alpha_i$ ,  $i = 0, \dots, n-1$  satisfying

$$\sum_{i=j}^{n-1} t_{ij} \alpha_i = \begin{cases} 0 & \text{if } j \neq n-k-1 \\ 1 & \text{if } j = n-k-1 \end{cases}.$$

Then

$$\begin{aligned}
 \sum_{i=0}^{n-1} \alpha_i (\lambda L_f - I)^i L_f^{n-i-1} &= \sum_{i=0}^{n-1} \sum_{j=0}^i \alpha_i \binom{i}{j} (-1)^{i-j} \lambda^j L_f^{n+j-i-1} \\
 &= \sum_{j=0}^{n-1} \sum_{i=j}^{n-1} \alpha_i \binom{i}{i-j} (-1)^j \lambda^{i-j} L_f^{n-j-1} \\
 &= L_f^k.
 \end{aligned}$$

If  $x \in R$  then

$$\begin{aligned}
 L_f^k x &= \sum_{i=0}^{n-1} (\lambda L_f - I)^i L_f^{n-i-1} (\alpha_i x) \\
 &\in L_f^{n-1} R + (\lambda L_f - I) L_f^{n-2} R + \cdots + (\lambda L_f - I)^{n-1} R
 \end{aligned}$$

and

$$R + L_f R + \cdots + L_f^{n-1} R = L_f^{n-1} R + (\lambda L_f - I) L_f^{n-2} R + \cdots + (\lambda L_f - I)^{n-1} R.$$

Setting  $R = \text{Im} B_f$  and observing that  $\mathcal{R}_f$  is  $(\lambda L_f - I)^{-1}$ -invariant gives

$$\mathcal{R}_f = (\lambda L_f - I)^{-1} \text{Im} B_f + (\lambda L_f - I)^{-2} L_f \text{Im} B_f + \cdots + (\lambda L_f - I)^{-n} L_f^{n-1} \text{Im} B_f.$$

Note that

$$L_f (\lambda L_f - I) = (\lambda L_f - I) L_f$$

so left and right multiplication by  $(\lambda L_f - I)^{-1}$  shows that  $(\lambda L_f - I)^{-1}$  and  $L_f$  commute. This establishes the desired expression for  $\mathcal{R}_f$ .

Finally, note that

$$\begin{aligned}
 (\lambda E - A)^{-1} E | S &= (\lambda I - L_s)^{-1} \\
 (\lambda E - A)^{-1} E | F &= (\lambda L_f - I)^{-1} L_f \\
 P(\lambda E - A)^{-1} B &= (\lambda I - L_s)^{-1} B_s \\
 Q(\lambda E - A)^{-1} B &= (\lambda L_f - I)^{-1} B_f
 \end{aligned}$$

so the pairs  $((\lambda E - A)^{-1} E | S, P(\lambda E - A)^{-1} B)$  and  $((\lambda E - A)^{-1} E | F, Q(\lambda E - A)^{-1} B)$  have controllable subspaces  $\mathcal{R}_s$  and  $\mathcal{R}_f$  respectively. Since  $(\lambda E - A)^{-1} E | S$  and

$(\lambda E - A)^{-1}E|F$  have disjoint spectra,  $((\lambda E - A)^{-1}E, (\lambda E - A)^{-1}B)$  has controllable subspace  $\mathcal{R}_s \oplus \mathcal{R}_f = \mathcal{R}$ . This completes the proof.

Theorem 3.4: The triple  $(E, A+BK, B)$  has controllable subspace  $\mathcal{R}$  for all  $K \in \text{Hom}(X, U)$  that satisfy (3.10).

Proof: Let  $\mathcal{R}_K$  be the controllable subspace of  $(E, A+BK, B)$ . For any subspace  $R$  of  $X$  and any  $\lambda \in C - (\sigma(E, A) \cup \sigma(E, A+BK))$  we have

$$(\lambda E - A - BK)(\lambda E - A)^{-1}(\text{Im}B + R) = (I - BK(\lambda E - A)^{-1})(\text{Im}B + R) \subset \text{Im}B + R$$

and

$$(\lambda E - A)^{-1}(\text{Im}B + R) = (\lambda E - A - BK)^{-1}(\text{Im}B + R)$$

since  $\lambda E - A - BK$  is invertible. Applying Lemma 3.2 gives

$$\begin{aligned} \mathcal{R} &= (\lambda E - A)^{-1}(\text{Im}B + E(\lambda E - A)^{-1}(\text{Im}B + E(\lambda E - A)^{-1}(\dots(\text{Im}B)\dots))) \\ &= (\lambda E - A - BK)^{-1}(\text{Im}B + E(\lambda E - A - BK)^{-1}(\text{Im}B + E(\lambda E - A - BK)^{-1}(\dots(\text{Im}B)\dots))) \\ &= \mathcal{R}_K \end{aligned}$$

and the proof is complete.

Henceforth, for notational simplicity, we shall denote the relevant subspaces and operators of the closed loop system (3.9) by  $S_K, F_K, M_K, L_{sK}, L_{fK}$ , etc.

### 3.4. Slow Feedback

Besides feedback invariance of the controller subspace, there does not appear to be much that can be said in general relating structural properties of open loop descriptor systems to those of closed loop ones. Fortunately, the pole placement problem can be dealt with by feeding back the slow and fast trajectories separately. The induced structural changes

can then be more easily characterized. In this section we consider feedback in the slow subsystem. That is, we apply a control  $u = Kx + v$  with

$$\text{Ker } K \supset F. \quad (3.13)$$

Let

$$K_s = K|_S \quad (3.14)$$

and let  $\mathcal{B}_s = (e_1, \dots, e_r)$  and  $\mathcal{B}_f = (e_{r+1}, \dots, e_n)$  be bases of  $S$  and  $F$  respectively. If  $\mathcal{B} = (e_1, \dots, e_n)$  then

$$\text{Mat}_{\mathcal{B}}(MEs - MA - MBK) = \begin{bmatrix} \text{Mat}_{\mathcal{B}_s}(Is - L_s - B_s K_s) & 0 \\ \text{Mat}_{\mathcal{B}_f \mathcal{B}_s}(-B_f K_s) & \text{Mat}_{\mathcal{B}_f}(L_f s - I) \end{bmatrix}. \quad (3.15)$$

Clearly, the eigenvalues of the closed loop system (3.9) are those of the operator  $L_s + B_s K_s$ . Hence we have the following extension of a well known result from state variable theory.

**Theorem 3.5:** An eigenvalue  $\lambda_i$  of the descriptor variable system (2.5) can be shifted arbitrarily by applying slow feedback if and only if the eigenspace of  $\lambda_i$  is contained in  $\mathcal{R}_s$ .

From (3.15) it follows that the dimensions of the slow and fast subspaces do not change when feedback is applied. In fact, the next result says that the fast subspace and fast subsystem are essentially unchanged by slow feedback.

**Theorem 3.6:** If  $K$  satisfies (3.10) and (3.13) then

$$F_K = F$$

$$L_{fK} = L_f$$

and

$$\mathcal{R}_{fK} = \mathcal{R}_f.$$

**Proof:** Choose  $\lambda \in C - (\sigma(E, A) \cup \sigma(E, A + BK))$  and observe that

$$\text{Mat}_{\mathbb{B}}((\lambda E - A - BK)^{-1}E) = \begin{bmatrix} \text{Mat}_{\mathbb{B}_s}(\lambda I - L_s - B_s K_s)^{-1} & 0 \\ \text{Mat}_{\mathbb{B}_f}(\lambda L_f - I)^{-1} B_f K_s (\lambda I - L_s - B_s K_s)^{-1} & \text{Mat}_{\mathbb{B}_f}(\lambda L_f - I)^{-1} L_f \end{bmatrix}.$$

Clearly,

$$F_K = \text{Ker}((\lambda E - A - BK)^{-1}E)^{n-r} = F.$$

Also, (3.13) implies

$$(\lambda E - A - BK)^{-1}E|F = (\lambda E - A)^{-1}E|F$$

so

$$\bar{M}_K|F = (\lambda J_{2K} - I)^{-1} = (\lambda J_2 - I)^{-1} = \bar{M}|F$$

and

$$L_{fK} = \bar{M}_K (\lambda E - A - BK)^{-1}E|F = \bar{M}(\lambda E - A)^{-1}E|F = L_f.$$

Finally,  $\mathcal{R}_{fK} = \mathcal{R}_K \cap F_K$ ,  $F_K = F$ , and Theorem 3.4 together imply  $\mathcal{R}_{fK} = \mathcal{R}_f$  so the proof is complete.

It is easy to construct examples where  $B_{fK} \neq B_f$ . Nevertheless, as we have just seen, the open and closed loop systems have the same fast controllable subspace.

### 3.5. Fast Feedback

Consider the control law  $u = Kx + v$  with

$$\text{Ker } K \supset S \tag{3.16}$$

and let

$$K_f = K|F. \tag{3.17}$$

Then

$$\text{Mat}_{\mathbb{R}}(MEs-MA-MBK) = \begin{bmatrix} \text{Mat}_{\mathbb{R}}(Is-L_s) & \text{Mat}_{\mathbb{R}}(-B_s K_f) \\ 0 & \text{Mat}_{\mathbb{R}}(L_f s - I - B_f K_f) \end{bmatrix}. \quad (3.18)$$

Clearly, the eigenvalues of the open loop system are also eigenvalues of the closed loop system. But  $\det(L_f s - I - B_f K_f)$  in general is not a constant polynomial so fast feedback may induce additional modes in the system.

If some of the roots of  $\det(L_f s - I - B_f K_f)$  are also eigenvalues of  $L_s$  then it is difficult to find a relationship between the open loop and closed loop eigenspace structures. However, this can be easily voided as we shall now see.

Let  $\mathcal{X}$  denote the subspace of  $\text{Hom}(X, U)$  consisting of all  $T$  satisfying  $\text{Ker } T \subset S$  and let  $\mathcal{J} \subset \mathcal{X}$  consist of all  $T$  satisfying  $\det(L_f s - I - B_f T_f) \neq 0$  and such that

$$\sigma(L_f, I + B_f T_f) \cap \sigma(E, A) = \emptyset \quad (3.19)$$

where  $T_f = T|_F$ . Let

$$\|T\| = \sup\{\|Tx\| \mid x \in X, \|x\| = 1\}. \quad (3.20)$$

Proposition 3.1:  $\mathcal{J}$  is open relative to  $\mathcal{X}$ .

Proof: The proof will be postponed until Chapter 4. See the discussion following Lemma 4.3.

Corollary: There exists  $\varepsilon > 0$  such that  $T \in \mathcal{X}$  and  $\|T\| < \varepsilon$  together imply that  $T \in \mathcal{J}$ .

Proof: Obviously  $0 \in \mathcal{J}$  so the result follows immediately from the proposition.

We next establish a threefold decomposition of the closed loop system. Let



$$\det(L_f s - I - B_f K_f) = \psi_0 \prod_{i=1}^h (s - \beta_i)^{g_i} \quad (3.21)$$

where  $\psi_0 \neq 0$  and  $i \neq j$  implies  $\beta_i \neq \beta_j$ . Henceforth we assume that  $K \in \mathcal{J}$  so  $\beta_i \neq \lambda_j$  for all  $i, j$ . Let  $\lambda \in C - \sigma(E, A+BK)$  and define

$$D_K = \bigoplus_{i=1}^h \text{Ker}((\lambda E - A - BK)^{-1} E - \frac{1}{\lambda - \beta_i} I)^{g_i}. \quad (3.22)$$

Lemma 2.1 guarantees that  $D_K$  is independent of  $\lambda$ .

Theorem 3.8: 1)  $S_K = S \oplus D_K$ .

2)  $S$  and  $D_K$  are both  $M_K E$ - and  $M_K(A+BK)$ -invariant with  $M_K(A+BK)|_S = L_S$ .

3)  $R_{SK} = R_S \oplus D_K$ .

Proof: 1) Let  $\lambda \in C - \sigma(E, A+BK)$  and define

$$\bar{S} = \bigoplus_{i=1}^r \text{Ker}((\lambda E - A - BK)^{-1} E - \frac{1}{\lambda - \lambda_i})^{n_i}.$$

Then  $S_K = \bar{S} \oplus D_K$ . Let  $x \in X$  with  $x = x_1 + x_2$ ,  $x_1 \in S$ , and  $x_2 \in F$ . Then

$$\begin{aligned} (\lambda E - A - BK)^{-1} E x &= (\lambda I - L_S)^{-1} x_1 + (\lambda I - L_S)^{-1} B_S K_f (\lambda L_f - I - B_f K_f)^{-1} L_f x_2 \\ &\quad + (\lambda L_f - I - B_f K_f)^{-1} L_f x_2 \end{aligned}$$

and there exists  $N \in \text{Hom}(F, S)$  such that

$$\bigoplus_{i=1}^k ((\lambda E - A - BK)^{-1} E - \frac{1}{\lambda - \lambda_i} I)^{n_i} x = N x_2 + \bigoplus_{i=1}^k ((\lambda L_f - I - B_f K_f)^{-1} L_f - \frac{1}{\lambda - \lambda_i} I)^{n_i} x_2.$$

Since  $K \in \mathcal{J}$ ,  $\frac{1}{\lambda - \lambda_i}$  is not an eigenvalue of  $(\lambda L_f - I - B_f K_f)^{-1} L_f$ <sup>5</sup> so

$(\lambda L_f - I - B_f K_f)^{-1} L_f - \frac{1}{\lambda - \lambda_i} I$  is invertible. Thus, if  $x \in \bar{S}$  we have  $x_2 = 0$  and  $x \in S$ . Conversely, suppose  $x \in S$ . Then

<sup>5</sup> See the proof of Theorem 2.1 for a discussion of the eigenvalues of  $(\lambda E - A)^{-1} E$  for any  $E$  and  $A$  with  $\lambda E - A$  invertible.

$$\prod_{i=1}^k ((\lambda E - A - BK)^{-1} E - \frac{1}{\lambda - \lambda_i} I) \prod_{i=1}^n x = 0$$

and  $x \in \bar{S}$  so  $S = \bar{S}$ .

2) We have immediately that  $S$  and  $D_K$  are  $(\lambda E - A - BK)^{-1} E$ -invariant,  $J_{1K}^{-1}$  and  $\bar{M}_K$ -invariant, and hence  $M_K E$ -invariant. From

$$(\lambda E - A - BK)^{-1} (A + BK) = \lambda (\lambda E - A - BK)^{-1} E - I$$

$M_K (A + BK)$ -invariance of  $S$  and  $D_K$  follows. From (3.16),

$$(\lambda E - A - BK)^{-1} E|_S = (\lambda E - A)^{-1} E|_S$$

so

$$\bar{M}_K|_S = J_{1K}^{-1}|_S = J_1^{-1} = \bar{M}|_S$$

and

$$\begin{aligned} M_K (A + BK)|_S &= \bar{M}_K (\lambda E - A - BK)^{-1} A|_S \\ &= \bar{M} (\lambda E - A)^{-1} A|_S \\ &= L_S. \end{aligned}$$

3) Clearly,

$$\text{Im}(\beta_i M E - M A - M B K) + \text{Im} M B = S \quad (\text{Im}(\beta_i L_f - I - B_f K_f) + \text{Im} B_f).$$

For  $x \in F$  let  $x_1 = (\beta_i L_f - I)^{-1} x$  and  $x_2 = K_f x_1$ . Then

$$(\beta_i L_f - I - B_f K_f) x_1 + B_f x_2 = x$$

and

$$\text{Im}(\beta_i L_f - I - B_f K_f) + \text{Im} B_f = F.$$

Hence, from Theorem 3.3, part 1),  $D_K \subset \mathcal{R}$ . Also  $D_K \subset S_K$  so

$$D_K \subset \mathcal{R} \cap S_K = \mathcal{R}_{sK}.$$

Furthermore, by Theorem 3.4,

$$\mathcal{R}_s = \mathcal{R} \cap S \subset \mathcal{R}_K \cap S_K = \mathcal{R}_{sK}$$

so

$$\mathcal{R}_{sK} \supset \mathcal{R}_s \oplus D_K.$$

To prove the converse let

$$x \in \mathcal{R}_{sK} = \mathcal{R}_K \cap S_K = \mathcal{R} \cap (S \oplus D_K).$$

Then  $x \in \mathcal{R}$  and there exist  $y \in S$ ,  $z \in D_K$  such that  $x = y + z$ . But  $y = x - z \in \mathcal{R} + D_K = \mathcal{R}$

so

$$x \in (\mathcal{R} \cap S) \oplus D_K = \mathcal{R}_s \oplus D_K$$

and

$$\mathcal{R}_{sK} \subset \mathcal{R}_s \oplus D_K.$$

This completes the proof.

Theorem 3.8 is analogous to Theorem 3.6. It states that the closed loop system consists of three subsystems: one acting on the open loop slow subspace  $S$  with eigenvalues  $\lambda_i$  and controllable subspace  $\mathcal{R}_s$ , one which is completely controllable acting on  $D_K$  with the induced eigenvalues  $\beta_i$ , and a fast subsystem acting on  $F_K$ . Although there is considerable structural reshuffling, the controllable subspace of the overall system  $\mathcal{R}$  remains unchanged.

If  $\text{rank } E = r$  then we can go even further. We already know that in this case the fast subspace does not change when feedback is applied. Since  $S \subset S_K$  and  $S_K \oplus F = X$  it follows that  $S = S_K$ . The next result says that not only are the slow and fast subspaces unchanged, but the entire system is essentially unaffected. This would seem to indicate that applying fast feedback to such a system is pointless. Recall that  $\text{rank } E = r$  implies  $L_f = 0$  so  $I + B_f K_f$  must be invertible for  $\det(L_f s - I - B_f K_f) \neq 0$  to hold.

Theorem 3.9: If  $\text{rank } E = r$  and  $K$  satisfies (3.10) and (3.16) then  $L_{sK} = L_s$ ,  $L_{fK} = 0$ ,  $B_{sK} = B_s (I - K_f (I + B_f K_f)^{-1} B_f)$ , and  $B_{fK} = (I + B_f K_f)^{-1} B_f$ .

Proof: Since  $F = \text{Ker } E$ ,  $L_{fK} = M_K E|F = 0$ . Also, if  $\lambda \in C - \sigma(E, A+BK)$  then

$$J_{1K} = (\lambda E - A - BK)^{-1} E|S = (\lambda E - A)^{-1} E|S = (\lambda I - L_S)^{-1}$$

and

$$\begin{aligned} L_{sK} &= \bar{M}_K (\lambda E - A - BK)^{-1} (A + BK)|S \\ &= J_{1K}^{-1} (\lambda E - A)^{-1} A|S \\ &= L_S. \end{aligned}$$

Next we have

$$P\bar{M}_K = J_{1K}^{-1} P$$

so

$$\begin{aligned} P\bar{M}_K B &= J_{1K}^{-1} P (\lambda E - A - BK)^{-1} MB \\ &= J_{1K}^{-1} ((\lambda I - L_S)^{-1} B_S - (\lambda I - L_S)^{-1} B_S K_f (I + B_f K_f)^{-1} B_f) \\ &= B_S (I - K_f (I + B_f K_f)^{-1} B_f). \end{aligned}$$

Finally,

$$Q\bar{M}_K = (\lambda J_{2K} - I)^{-1} Q$$

so

$$\begin{aligned} Q\bar{M}_K B &= (\lambda J_{2K} - I)^{-1} Q (\lambda E - A - BK)^{-1} MB \\ &= -(\lambda J_{2K} - I)^{-1} (I + B_f K_f)^{-1} B_f. \end{aligned}$$

But

$$J_{2K} = (E - A - BK)^{-1} E|F = 0$$

which gives the desired result.

To conclude this chapter we consider the problem of eliminating the impulsive portion of the fast trajectory (2.24) by applying fast feedback.

The result that we shall obtain says that it is possible to eliminate impulsive behavior if and only if the fast subsystem (except for the part acting on  $\text{Ker } L_f$ ) is controllable. First we need a lemma.

Lemma 3.3: Let  $Y$  and  $Z$  be finite-dimensional  $C$ -vector spaces with  $\dim Y = \dim Z$ . Let  $N \in \text{Hom}(Y, Z)$  and  $G \in \text{Hom}(U, Z)$ . There exists  $H \in \text{Hom}(Y, U)$  such that  $N + GH$  is invertible if and only if  $\text{Im } N + \text{Im } G = Z$ .

Proof: If  $N$  is invertible then the result is obvious. Let  $N$  be noninvertible and choose bases of  $Y$ ,  $Z$ , and  $U$ . The existence of an appropriate  $H$  is equivalent to controllability of the mode 0 of the pair  $(\text{Mat}N, \text{Mat}G)$  which is equivalent to

$$\text{Im}N + \text{Im}G = Z$$

so the proof is complete.

Let  $F/\text{Ker}L_f$  be the quotient space of  $F$  modulo  $\text{Ker}L_f$ ,  $W \in \text{Hom}(F, F/\text{Ker}L_f)$  the canonical surjection, and  $\hat{L}_f$  the induced map of  $L_f$ .

Proposition 3.2:  $\hat{L}_f$  is nilpotent with index of nilpotency  $q-1$ .

Proof:  $\hat{L}_f$  is uniquely defined by  $WL_f = \hat{L}_f W$ . Assume

$$WL_f^p = \hat{L}_f^p W. \quad (3.23)$$

Then

$$WL_f^{p+1} = \hat{L}_f^p WL_f = L_f^{p+1} W.$$

Hence (3.23) holds for  $p = 1, 2, 3, \dots$

Next, note that if  $x \in \text{Im}L_f^{q-1}$  then there exists  $y \in F$  with  $x = L_f^{q-1}y$ .

Thus  $L_f^q x = L_f^q y = 0$  and

$$\text{Im}L_f^{q-1} \subset \text{Ker}L_f = \text{Ker}W$$

so

$$\hat{L}_f^{q-1} W = WL_f^{q-1} = 0$$

and, since  $W$  is a surjection,  $\hat{L}_f^{q-1} = 0$ .

On the other hand, there exists  $y \in F$  with  $L_f^{q-1}y \neq 0$  so

$$\text{Im}L_f^{q-2} \not\subset \text{Ker}L_f.$$

Thus

$$\hat{L}_f^{q-2} W = WL_f^{q-2} \neq 0$$

and  $\hat{L}_f^{q-2} \neq 0$ . This completes the proof.

Letting  $\hat{B}_f = WB_f$  and  $\hat{x}_f(t) = Wx_f(t)$ , we may define the quotient system

$$\hat{L}_f \dot{\hat{x}}_f = \hat{x}_f + \hat{B}_f u. \quad (3.24)$$

Since  $\hat{L}_f$  is nilpotent, (3.24) has similar structural properties to those of the fast subsystem (2.20). In particular, from Theorem 3.3, part 2) it follows that (3.24) is completely controllable if and only if  $\text{Im} \hat{L}_f + \text{Im} \hat{B}_f = F / \text{Ker } L_f$ . We shall make use of this fact in the final theorem of this chapter. Note that no  $\delta$ -functions are present in (2.24) if and only if  $L_f = 0$ .

Theorem 3.10: The following statements are equivalent:

- 1) There exists  $K \in \text{Hom}(X, U)$  satisfying (3.10) such that  $L_{fK} = 0$ .
- 2) There exists  $K \in \text{Hom}(X, U)$  satisfying (3.10) and (3.16) such that  $L_{fK} = 0$ .
- 3)  $\text{Im} L_f + \text{Im} B_f + \text{Ker} L_f = F$ .
- 4) The quotient system (3.24) is completely controllable.

Proof: Choosing bases of  $S$  and  $F$ , it is clear from the matrix representation of  $Ex - MA - MBK$  that, for any  $K$ ,

$$\deg(\det(Es - A - BK)) = r + \deg(\det(L_f s - I - B_f K_f)).$$

From (2.15),  $L_{fK} = 0$  if and only if

$$\deg(\det(Es - A - BK)) = \text{rank } E$$

or equivalently,

$$\deg(\det(L_f s - I - B_f K_f)) = \text{rank } L_f$$

since

$$\text{rank } E = r + \text{rank } L_f.$$

Whether or not  $L_{fK} = 0$  is therefore determined solely by the action of  $K$  on  $F$ .

The behavior of  $K$  on  $S$  is irrelevant and the equivalence of 1) and 2) follows.

Choose a basis  $= (e_1, \dots, e_{p_1}, e_{p_1+1}, \dots, e_{p_2}, \dots, e_{p_{d-1}+1}, \dots, e_{p_d})$  of  $F$  so that  $\text{Mat}_{\mathbb{R}} L_f$  is in Jordan form with  $d$  blocks of sizes  $p_{i+1} - p_i$ . Let  $\text{Mat}_{\mathbb{R}} (I + B_f K_f) = [h_{ij}]$ . A straightforward but notationally messy calculation yields that the  $(\text{rank } L_f)$ th coefficient of  $\det(L_f s - I - B_f K_f)$  is just  $\det \Theta$  where, setting  $p_0 = 0$ ,  $\Theta = [\theta_{ij}]$  with

$$\theta_{ij} = h_{p_i, p_{j-1}+1}.$$

1) is equivalent to  $\det \Theta \neq 0$  for some  $K_f$ . Note that

$$\text{Im } L_f = \text{span}\{e_j \mid j = p_{i-1}+1, \dots, p_i-1; i = 1, \dots, d\}$$

and

$$\text{Ker } L_f = \text{span}\{e_1, e_{p_1+1}, \dots, e_{p_{d-1}+1}\}.$$

Let  $T = \text{span}\{e_{p_1}, e_{p_2}, \dots, e_{p_d}\}$ .

Then  $\dim(\text{Ker } L_f) = \dim T$  and 1) is equivalent to the statement that

$P_{T \text{Im } L_f} (I + B_f K_f) | \text{Ker } L_f$  is invertible for some  $K_f$  where  $P_{T \text{Im } L_f}$  is the skew projection operator on  $T$  along  $\text{Im } L_f$ . Let  $V = P_{T \text{Im } L_f}$ . Then

$$V(I + B_f K_f) | \text{Ker } L_f = V | \text{Ker } L_f + (V B_f)(K_f | \text{Ker } L_f)$$

and from Lemma 3.3 an appropriate  $K_f$  may be found if and only if

$$V(\text{Ker } L_f + \text{Im } B_f) = \text{Im } V | \text{Ker } L_f + \text{Im } V B_f = T.$$

Hence we have arrived at the equivalence of 3).

Complete controllability of (3.24) is equivalent to

$$\text{Im } \hat{L}_f + \text{Im } \hat{B}_f = F / \text{Ker } L_f$$

so the equivalence of 3) and 4) follows from elementary arguments.

Since 1) implies 2) in Theorem 3.10, we are guaranteed that if the impulsive behavior of the fast subsystem can be eliminated by feedback then it can be eliminated by fast feedback. Theorem 3.10 may be interpreted as a pole placement theorem concerned with shifting poles at infinity into the finite portion of the complex plane. Theorem 3.8 says that the shifted poles correspond to controllable modes and can thus be placed arbitrarily.

### 3.6. A Two-Stage Pole Placement Procedure

The following design procedure can be used for pole placement in the overall descriptor system. First, calculate the decomposition for the given open loop system. If the fast subsystem modulo  $\text{Ker } L_f$  is completely controllable then any impulsive behavior can be eliminated by applying fast feedback as outlined in the corollary to Proposition 3.1 and Lemma 3.3.

Second, calculate the decomposition of the closed loop system after fast feedback has been applied and shift the poles of the slow subsystem as desired. The properties listed in Theorem 3.8 make calculating the decomposition easier.



PART TWO

SINGULAR PERTURBATION THEORY

## CHAPTER 4

## DECOMPOSITION OF GENERALIZED SINGULARLY PERTURBED SYSTEMS

4.1. Preliminaries

As shown in Chapter 1, there is a need for a singular perturbation theory which not only unifies existing theories, but also extends them to a larger class of systems. In this Chapter, after defining the generalized singularly perturbed system, we shall develop a geometric decomposition of the system into slow and fast subsystems. Such a decomposition will have use in Chapter 5 in the study of the behavior of the solutions of (4.8). It will also be useful in studying the behavior of the solution to the LQ regulator problem in Chapter 7. For the standard form (1.5), approximate decompositions already exist (see, for example, [15]). We shall take a somewhat different approach from what has been done in the past, extending the geometric decomposition developed in Chapter 2 to systems defined on a parameter space. The decomposition will be exact in contrast to the approximate decoupling result of [15]. In order to develop the theory we shall need certain mathematical concepts. Consider the set  $\mathcal{M}$  of all subspaces of  $X$ . For any  $R \in \mathcal{M}$  let  $P_R \in \text{Hom}(X, X)$  be the orthogonal projection operator on  $R$ . Define  $\rho: \mathcal{M}^2 \rightarrow [0, \infty)$  by

$$\rho(R, T) = \|P_R - P_T\|. \quad (4.1)$$

It is shown in [33], pp. 69-71 that  $\rho$  is a metric with values in  $[0, 1]$  and that  $\rho(R, T) = 1$  if and only if either  $R^\perp \cap T \neq 0$  or  $R \cap T^\perp \neq 0$ . From a dimensionality argument it follows that  $\rho(R, T) = 1$  when  $\dim R \neq \dim T$ .  $\rho$  can be thought of as a generalization of the angle between subspaces.

Let  $\Omega$  be a topological space (see, for example, [28]) and choose  $\omega_0 \in \Omega$ . If  $R: \Omega \rightarrow \mathcal{M}$  is continuous at  $\omega_0$  with respect to  $\rho$ , it will be useful to construct a convergent basis for  $R$ . To do this we need a pair of lemmas.

**Lemma 4.1.** Let  $y, e_i: \Omega \rightarrow X, i=1, \dots, n$  be continuous at  $\omega_0$  with  $(e_1(\omega), \dots, e_n(\omega))$  a basis of  $X$  for all  $\omega \in \Omega$ . If  $\alpha_i: \Omega \rightarrow \mathbb{C}, i=1, \dots, n$  are defined by  $y(\omega) = \alpha_1(\omega)e_1(\omega) + \dots + \alpha_n(\omega)e_n(\omega)$  then each  $\alpha_i$  is continuous at  $\omega_0$ .

**Proof:** Define  $L: \Omega \rightarrow \text{Hom}(X, X)$  according to

$$L(\omega)e_i(\omega_0) = e_i(\omega), \quad i=1, \dots, n.$$

Then  $L$  is continuous at  $\omega_0$  and  $L(\omega)$  is invertible for each  $\omega \in \Omega$ . Taking the inverse of  $L(\omega)$  corresponds to a continuous function on the topological subspace of invertible endomorphisms in  $\text{Hom}(X, X)$ . Hence  $\omega \rightarrow L(\omega)^{-1}$  is continuous at  $\omega_0$ . It follows from

$$\begin{aligned} \|L(\omega)^{-1}y(\omega) - L(\omega_0)^{-1}y(\omega_0)\| &\leq \|L(\omega)^{-1} - L(\omega_0)^{-1}\| \|y(\omega)\| \\ &\quad + \|L(\omega_0)^{-1}\| \|y(\omega) - y(\omega_0)\| \end{aligned}$$

so  $\omega \rightarrow L(\omega)^{-1}y(\omega)$  is continuous at  $\omega_0$ . Define  $\beta_i: \Omega \rightarrow \mathbb{C}$  according to

$$L(\omega)^{-1}y(\omega) = \beta_1(\omega)e_1(\omega_0) + \dots + \beta_n(\omega)e_n(\omega_0).$$

Then each  $\beta_i$  is continuous at  $\omega_0$ . It follows that

$$\begin{aligned} y(\omega) &= L(\omega)(\beta_1(\omega)e_1(\omega_0) + \dots + \beta_n(\omega)e_n(\omega_0)) \\ &= \beta_1(\omega)e_1(\omega) + \dots + \beta_n(\omega)e_n(\omega) \end{aligned}$$

so  $\alpha_i = \beta_i, i=1, \dots, n$  and the proof is complete.

**Lemma 4.2.** Let  $L: \Omega \rightarrow \text{Hom}(X, X)$  be continuous at  $\omega_0$  with  $(v_1, \dots, v_p)$  a basis of  $\text{Ker } L(\omega_0)$ . There exists a neighborhood  $V$  of  $\omega_0$  and maps  $e_i: V \rightarrow X, i=1, \dots, p$  such that

- 1)  $e_i$  is continuous at  $\omega_0$ ,  $i = 1, \dots, p$ .
- 2)  $e_i(\omega_0) = v_i$ ,  $i = 1, \dots, p$ .
- 3)  $(e_1(\omega), \dots, e_p(\omega))$  is linearly independent  $\forall \omega \in V$ .
- 4)  $\text{span} \{e_1(\omega), \dots, e_p(\omega)\} \supset \text{Ker } L(\omega) \forall \omega \in V$ .
- 5)  $\omega \rightarrow \text{span} \{e_1(\omega), \dots, e_p(\omega)\}$  is continuous at  $\omega_0$ .

Proof: Choose a basis  $(b_1, \dots, b_{n-p})$  of  $\text{Im } L(\omega_0)$  and define  $c_i : \Omega \rightarrow X$ ,  $i = 1, \dots, n-p$  according to  $c_i(\omega) = L(\omega)^* b_i$ . Then  $c_i(\omega) \in \text{Ker } L(\omega)^\perp$ . Furthermore,  $(b_1, \dots, b_{n-p})$  is a basis of  $\text{Ker } L(\omega_0)^{\perp}$  so  $(c_1(\omega_0), \dots, c_{n-p}(\omega_0))$  is a basis of  $\text{Im } L(\omega_0)^* = \text{Ker } L(\omega_0)^\perp$ . Since the points in  $X^{n-p}$  which correspond to linearly independent sets of vectors form an open set, there is a neighborhood  $V_1$  of  $\omega_0$  throughout which  $(c_1(\omega), \dots, c_{n-p}(\omega))$  is linearly independent. Taking the adjoint corresponds to a continuous function on  $\text{Hom}(X, X)$  so  $\omega \rightarrow L(\omega)^*$  is continuous at  $\omega_0$ .  $\|c_i(\omega) - c_i(\omega_0)\| \leq \|L(\omega)^* - L(\omega_0)^*\| \|b_i\|$  gives that  $c_i$  is continuous at  $\omega_0$ ,  $i = 1, \dots, n-p$ .

Applying the projection theorem (see [27], p. 56) yields the orthogonal projection  $\beta_{i1}(\omega)c_1(\omega) + \dots + \beta_{i, n-p}(\omega)c_{n-p}(\omega)$  of  $v_i$  on  $\text{span} \{c_1(\omega), \dots, c_{n-p}(\omega)\} \subset \text{Ker } L(\omega)^\perp$  where  $\beta_{ij} : V_1 \rightarrow \mathbb{C}$  is given by

$$\begin{bmatrix} \langle c_1(\omega), c_1(\omega) \rangle & \dots & \langle c_1(\omega), c_{n-p}(\omega) \rangle \\ \vdots & & \vdots \\ \langle c_{n-p}(\omega), c_1(\omega) \rangle & \dots & \langle c_{n-p}(\omega), c_{n-p}(\omega) \rangle \end{bmatrix} \begin{bmatrix} \beta_{i1}(\omega) \\ \vdots \\ \beta_{i, n-p}(\omega) \end{bmatrix} = \begin{bmatrix} \langle v_i, c_1(\omega) \rangle \\ \vdots \\ \langle v_i, c_{n-p}(\omega) \rangle \end{bmatrix}.$$

Clearly, each  $\beta_{ij}$  is continuous at  $\omega_0$ .

Define  $e_i$  on  $V_1$  by

$$e_i(\omega) = v_i - (\beta_{i1}(\omega)c_1(\omega) + \dots + \beta_{i, n-p}(\omega)c_{n-p}(\omega)).$$

Then each  $e_i$  is continuous at  $\omega_0$ . Also,

$$v_i = \text{span} \{c_1(\omega_0), \dots, c_{n-p}(\omega_0)\}$$

so  $e_i(\omega_0) = v_i$ ,  $i = 1, \dots, p$  and there exists a neighborhood  $V \subset V_1$  of  $\omega_0$  throughout which  $(e_1(\omega), \dots, e_p(\omega))$  is linearly independent. Restricting  $e_i$  to  $V$ , 1) - 3) hold.

Since

$$e_i(\omega) \in \text{span} \{c_1(\omega), \dots, c_{n-p}(\omega)\}^\perp,$$

from a dimensionality argument it follows that

$$\text{span}\{e_1(\omega), \dots, e_p(\omega)\} = \text{span}\{c_1(\omega), \dots, c_{n-p}(\omega)\}^\perp \supset \text{Ker } L(\omega)$$

for all  $\omega \in V$ . Finally, let  $x \in X$ . From lemma 4.3 there exist  $\alpha_i : \Omega \rightarrow \mathbb{C}$ ,  $i = 1, \dots, n$ , continuous at  $\omega_0$ , such that

$$x = \alpha_1(\omega)e_1(\omega) + \dots + \alpha_p(\omega)e_p(\omega) + \alpha_{p+1}(\omega)c_1(\omega) + \dots + \alpha_n(\omega)c_{n-p}(\omega)$$

for all  $\omega \in V$ . Then

$$P \text{span}\{e_1(\omega), \dots, e_p(\omega)\}^x = \alpha_1(\omega)e_1(\omega) + \dots + \alpha_p(\omega)e_p(\omega)$$

so  $\omega \rightarrow P \text{span}\{e_1(\omega), \dots, e_p(\omega)\}^x$  is continuous at  $\omega_0$  and so is  $\omega \rightarrow \text{span}\{e_1(\omega), \dots, e_p(\omega)\}$ . This completes the proof.

Corollary: Let  $(v_1, \dots, v_p)$  be a basis of  $R(\omega_0)$ . There exist a neighborhood  $V$  of  $\omega_0$  and maps  $e_i : \Omega \rightarrow X$ ,  $i = 1, \dots, p$ , continuous at  $\omega_0$ , with  $e_i(\omega_0) = v_i$ ,  $i = 1, \dots, p$  and  $(e_1(\omega), \dots, e_p(\omega))$  a basis of  $R(\omega)$  for each  $\omega \in V$ .

Proof: Since  $R$  is continuous at  $\omega_0$ ,  $\dim R(\omega) = p$  for all  $\omega$  in some neighborhood of  $\omega_0$ . Setting

$$L(\omega) = P_{R(\omega)} - I - P_{R(\omega)}$$

and applying 1) - 4) give the desired result.

We shall shortly be considering parametrically varying linear operators. Unfortunately, their domains may also depend on a parameter. Hence, in order to talk about continuous behavior locally about the singular point, it is necessary to topologize the set

$$\mathcal{X} = \bigcup_{R \in \mathcal{M}} \text{Hom}(R, R). \quad (4.2)$$

To do this define  $\mu : \mathcal{X} \rightarrow \text{Hom}(X, X)$  according to

$$\mu(T)x = \begin{cases} Tx & \text{if } x \in R \\ 0 & \text{if } x \in R^\perp \end{cases}. \quad (4.3)$$

$\text{Hom}(X, X)$  has the topology induced by the operator norm (3.20). Let  $\mathcal{F}(X)$  be the weakest topology on  $\mathcal{X}$  that makes  $\mu$  continuous. The topological space  $(\mathcal{X}, \mathcal{F}(X))$  is pseudometrizable with pseudometric

$$d_X(T_1, T_2) = \|\mu(T_1) - \mu(T_2)\|. \quad (4.4)$$

Hence, a map  $L : \Omega \rightarrow \mathcal{X}$  is continuous at  $\omega_0$  if and only if  $\mu \circ L$  is continuous at  $\omega_0$  in the usual norm sense. Define  $H(X)$  to be the set of all  $L : \Omega \rightarrow \mathcal{X}$  continuous at  $\omega_0$ .

If  $R : \Omega \rightarrow \mathcal{M}$  is continuous at  $\omega_0$  we denote by  $H_R(X)$  the set of all  $L \in H(X)$  with  $L(\omega) \in \text{Hom}(R(\omega), R(\omega))$  for each  $\omega \in \Omega$ . If  $G \in \mathcal{M}$  and  $R(\omega) = G$  for all  $\omega$  then  $H_G(X)$  is alternative notation for  $H_R(X)$ . Note that  $\text{Hom}(G, G) \subset \mathcal{X}$  with

$$\|T\| = \|\mu(T)\| \quad (4.5)$$

for any  $T \in \text{Hom}(G, G)$ . Thus, considering  $\text{Hom}(G, G)$  as a topological subspace of  $\mathcal{X}$ , the relative topology on  $\text{Hom}(G, G)$  is the same as the norm topology. Therefore,  $L : \Omega \rightarrow \text{Hom}(G, G)$  is contained in  $H_G(X)$  if and only if it is con-

tinuous at  $\omega_0$  with respect to the norm topology on  $\text{Hom}(G,G)$ .

Consider a locally continuous  $R : \Omega \rightarrow \mathcal{M}$  and  $L \in H_R(X)$ . Let  $V$  be a neighborhood of  $\omega_0$  and  $e_1, \dots, e_p$  basis functions as described in the corollary of lemma 4.2. Then

$$\begin{aligned} & \|L(\omega)e_i(\omega) - L(\omega_0)e_i(\omega_0)\| = \|\mu(L(\omega))e_i(\omega) - \mu(L(\omega_0))e_i(\omega_0)\| \\ & \leq \|(\mu \circ L)(\omega) - (\mu \circ L)(\omega_0)\| \|e_i(\omega_0)\| + \|\mu(L(\omega_0))\| \|e_i(\omega) - e_i(\omega_0)\| \end{aligned} \quad (4.6)$$

so  $\omega \rightarrow L(\omega)e_i(\omega)$  is continuous at  $\omega_0$ ,  $i=1, \dots, p$ . It follows from lemma 4.1 that the matrix representation of  $L(\omega)$ , defined on  $V$  with respect to  $e_1, \dots, e_p$ , varies continuously with the parameter about the singular point.

Proceeding similarly, let

$$\mathcal{U} = \bigcup_{R \in \mathcal{M}} \text{Hom}(U, R) \quad (4.7)$$

and define  $\nu : \mathcal{U} \rightarrow \text{Hom}(U, X)$  by  $\nu(T)u = Tu$  for any  $u \in U$ .  $\nu$  simply extends range spaces to  $X$ . Letting  $\mathfrak{F}(U)$  be the weakest topology on  $\mathcal{U}$  that makes  $\nu$  continuous, define  $H(U)$  to be the set of all  $L : \Omega \rightarrow \mathcal{U}$ , continuous at  $\omega_0$  with respect to  $\mathfrak{F}(U)$ . If  $R : \Omega \rightarrow \mathcal{M}$  is continuous at  $\omega_0$ , let  $H_R(U)$  consist of all  $L \in H(U)$  with  $L(\omega) \in \text{Hom}(U, R(\omega))$  for all  $\omega$ . Local continuity of matrix representations of members of  $H_R(U)$  can easily be shown.

In dealing with singularly perturbed systems we shall consider only operator valued maps in  $H_R(X)$  and  $H_R(U)$  for some  $R$ , continuous at  $\omega_0$ . Hence, all systems that we shall consider will have locally continuous matrix representations. Since matrix representations are inevitably used in applications we are justified in developing a theory which guarantees local continuity with respect to the topologies  $\mathfrak{F}(X)$  and  $\mathfrak{F}(U)$ . For theoretical purposes, however, abstract topological concepts are preferred

over notions of matrix convergence since the abstract approach is coordinate free.

We need a few more results concerning  $H_R(X)$  and  $H_R(U)$ . Let  $R: \Omega \rightarrow \mathcal{M}$  be continuous at  $\omega_0$ .

**Proposition 4.1.** 1) Let  $L \in H_X(X)$  and let  $R(\omega)$  be  $L(\omega)$ -invariant for all  $\omega \in \Omega$ . Then  $\omega \rightarrow L(\omega) \upharpoonright R(\omega)$  is continuous at  $\omega_0$ .

2) If  $\lambda: \Omega \rightarrow \mathbb{C}$  is continuous at  $\omega_0$  and  $L \in H(X)$  then  $\omega \rightarrow \lambda(\omega)L(\omega)$  is continuous at  $\omega_0$ .

3) If  $L_1, L_2 \in H(X)$  such that, for each  $\omega \in \Omega$ ,  $L_1(\omega)$  and  $L_2(\omega)$  share the same domain, then  $\omega \rightarrow L_1(\omega) + L_2(\omega)$  is continuous at  $\omega_0$ .

4) If  $L \in H_R(X)$  and  $L(\omega)$  is invertible for each  $\omega \in \Omega$  then  $\omega \rightarrow L(\omega)^{-1}$  is continuous at  $\omega_0$ .

5) If  $G: \Omega \rightarrow \mathcal{M}$  and  $v: \Omega \rightarrow X$  are continuous at  $\omega_0$  with  $R(\omega) \ominus G(\omega) = X$  for all  $\omega \in \Omega$  then  $\omega \rightarrow P_{R(\omega)G(\omega)}^{v(\omega)} \upharpoonright^1$  and  $\omega \rightarrow P_{G(\omega)R(\omega)}^{v(\omega)}$  are continuous at  $\omega_0$ .

6) If  $B \in H_X(U)$  then  $\omega \rightarrow P_{R(\omega)G(\omega)}^{B(\omega)}$  and  $\omega \rightarrow P_{G(\omega)R(\omega)}^{B(\omega)}$  are continuous at  $\omega_0$ .

**Proof:** 1) Let  $x \in X$  and  $e_1, \dots, e_p$  be as in the corollary to lemma 4.2. Since  $P_{R(\omega)^\perp} = I - P_{R(\omega)}$ ,  $\omega \rightarrow R(\omega)^\perp$  is continuous at  $\omega_0$  and  $e_{p+1}, \dots, e_n$  may be constructed to form a locally continuous basis for  $R(\omega)^\perp$ . As in lemma 4.1 construct  $\alpha_1, \dots, \alpha_n$  such that

$$x = \alpha_1(\omega)e_1(\omega) + \dots + \alpha_n(\omega)e_n(\omega).$$

Then

$$\omega \rightarrow (L(\omega) \upharpoonright R(\omega))x = \sum_{i=1}^p \alpha_i(\omega)L(\omega)e_i(\omega)$$

---

$\upharpoonright^1_{P_{R(\omega)G(\omega)}} \in \text{Hom}(X, R(\omega))$  is the skew projection operator on  $R(\omega)$  along  $G(\omega)$ .



and  $\omega \rightarrow \mu(L(\omega) | R(\omega))$  is continuous at  $\omega_0$ .

2) This follows immediately from

$$\mu(\lambda(\omega)L(\omega)) = \lambda(\omega)\mu(L(\omega)).$$

3) The result follows from

$$\mu(L_1(\omega) + L_2(\omega)) = \mu(L_1(\omega)) + \mu(L_2(\omega)).$$

4) Construct a locally continuous matrix representation with respect to a basis  $(e_1, \dots, e_p)$  on a neighborhood  $V$  of  $\omega_0$ . The inverse of  $\text{Mat } L(\omega)$  also varies continuously at  $\omega_0$ . Define  $\beta_{ij} : V \rightarrow \mathbb{C}$  according to

$$\text{Mat } L(\omega)^{-1} = [\beta_{ij}(\omega)].$$

Choose  $x \in X$  and construct  $\alpha_1, \dots, \alpha_p$  as in 1). Then

$$\mu(L(\omega)^{-1})x = \sum_{i=1}^p \alpha_i(\omega) L(\omega)^{-1} e_i(\omega) = \sum_{i=1}^p (\alpha_i(\omega) \sum_{j=1}^p \beta_{ji}(\omega) e_j(\omega)).$$

5) Choose basis functions  $e_1, \dots, e_p$  for  $R$  and  $e_{p+1}, \dots, e_n$  for  $G$ , and let  $\alpha_1, \dots, \alpha_n$  satisfy

$$v(\omega) = \alpha_1(\omega) e_1(\omega) + \dots + \alpha_n(\omega) e_n(\omega).$$

Then

$$P_{R(\omega)G(\omega)} v(\omega) = \alpha_1(\omega) e_1(\omega) + \dots + \alpha_p(\omega) e_p(\omega).$$

6) Let  $u \in U$ . Then

$$v(P_{R(\omega)G(\omega)} B(\omega))u = P_{R(\omega)G(\omega)} B(\omega)u.$$

Letting

$$v(\omega) = B(\omega)u = v(B(\omega))u$$

we have that  $v$  is continuous at  $\omega_0$ . The desired result follows from 5) and the proof is complete.

#### 4.2. Eigenvalue Behavior

We shall now construct a singularly perturbed system. We call  $\Omega$  the parameter space and  $\omega_0$  the singular point. For applications, the importance of non-Euclidean parameter spaces is not as yet clear. However, for our purposes, the structure of a topological space will be sufficient. We shall not cloud the relevant issues by imposing additional structure on  $\Omega$ .

A generalized singularly perturbed system is a family of linear time-invariant systems described by

$$E(\omega)\dot{x} = A(\omega)x + B(\omega)u \quad (4.8)$$

where  $E, A \in H_X(X)$ ,  $B \in H_X(U)$ , and  $\omega$  ranges over  $\Omega$ . Furthermore, we require that

$$\det(E(\omega_0)s - A(\omega_0)) \neq 0 \quad (4.9)$$

and that  $E(\omega_0)$  be singular.

The singularity of  $E(\omega_0)$  and the continuity of  $E$  and  $A$  at  $\omega_0$  work together to create the "singular" behavior of singularly perturbed systems. For example, we shall now see that, in general, systems of the form (4.8) have eigenvalues which can be separated into two classes according to magnitudes in a natural way.

Consider the characteristic polynomial  $\det(E(\omega)s - A(\omega))$  of (4.8). Since forming the determinant involves only sums and products of the entries of  $E(\omega)$  and  $A(\omega)$  we have

$$\det(E(\omega)s - A(\omega)) = \gamma_n(\omega)s^n + \dots + \gamma_1(\omega)s + \gamma_0(\omega) \quad (4.10)$$

where  $\gamma_i : \Omega \rightarrow \mathbb{C}$  is continuous at  $\omega_0$ ,  $i = 0, \dots, n$ . Let

$$r = \max\{i \mid \gamma_i(\omega_0) \neq 0\}. \quad (4.11)$$

**Lemma 4.3.** Let  $f(\omega, s) = \gamma_n(\omega)s^n + \dots + \gamma_0(\omega)$  where  $\gamma_i : \Omega \rightarrow \mathbb{C}$ ,  $i = 0, \dots, n$  are continuous at  $\omega_0$  satisfying  $\gamma_{r+1}(\omega_0) = \dots = \gamma_n(\omega_0) = 0$ ,  $\gamma_r(\omega_0) \neq 0$ ,  $r < n$ , but otherwise arbitrary. Then there exists a neighborhood  $V$  of  $\omega_0$  and maps  $\varphi_0, \lambda_1, \dots, \lambda_r, \sigma_1, \dots, \sigma_{n-r} : V \rightarrow \mathbb{C}$ , continuous at  $\omega_0$ , with  $\sigma_i(\omega_0) = 0$ ,  $i = 1, \dots, r$ ,  $\varphi_0(\omega) \neq 0$  for all  $\omega$ , and such that

$$f(\omega, s) = \varphi_0(\omega) \left( \prod_{i=1}^{n-r} (\sigma_i(\omega)s - 1) \right) \left( \prod_{i=1}^r (s - \lambda_i(\omega)) \right)$$

for every  $\omega \in V$ .

**Proof:** Let  $g(\omega, s) = \gamma_n(\omega)s^n + \dots + \gamma_r(\omega)$ . A bound on the roots of a polynomial over  $\mathbb{C}$  given in [26], p. 62 implies that there exists at least one root  $\delta_\omega$  of  $g(\omega, s)$  satisfying

$$|\delta_\omega| \leq \left| \frac{\gamma_n(\omega)}{\gamma_r(\omega)} \right| \prod_{i=1}^r \left( 1 - \frac{n-r}{i} \right)^{\frac{1}{n-r}} \quad (4.12)$$

whenever  $\gamma_r(\omega) \neq 0$ . Since  $\gamma_r(\omega_0) \neq 0$ , there is a neighborhood  $V_1$  of  $\omega_0$  throughout which (4.12) holds. Define  $\sigma_1$  on  $V_1$  according to

$$\sigma_1(\omega) = \begin{cases} \delta_\omega & \text{if } \gamma_n(\omega) \neq 0 \\ 0 & \text{if } \gamma_n(\omega) = 0 \end{cases}.$$

The construction of  $\sigma_1$  guarantees that if 0 is a root of  $g(\omega, s)$  then  $\sigma_1(\omega) = 0$ . From (4.12)  $\sigma_1$  is continuous at  $\omega_0$  with  $\sigma_1(\omega_0) = 0$ .

Let  $C(V_1)$  be the set of all maps from  $V_1$  into  $\mathbb{C}$ , continuous at  $\omega_0$ . Using pointwise addition and multiplication,  $C(V_1)$  is a commutative ring with identity. Hence (see [25], p. 334) there exist  $\bar{\gamma}_0, \dots, \bar{\gamma}_{n-1} \in C(V_1)$  such that

$$g = (s - \sigma_1)(\bar{Y}_0 s^{n-1} + \dots + \bar{Y}_{n-1})$$

where  $g$  is considered as a polynomial over  $C(V_1)$ . Multiplying and equating coefficients at  $\omega_0$  yields  $\bar{Y}_{r+1}(\omega_0) = \dots = \bar{Y}_{n-1}(\omega_0) = 0$  and  $\bar{Y}_r(\omega_0) \neq 0$ .

The above arguments may be applied  $n-r$  times yielding a neighborhood  $V_{n-r}$  of  $\omega_0$  and maps  $\sigma_1, \dots, \sigma_{n-r}, \varphi_0, \dots, \varphi_r : V \rightarrow C$ , continuous at  $\omega_0$  with  $\sigma_1(\omega_0) = \dots = \sigma_{n-r}(\omega_0) = 0$  such that

$$g = (-1)^{n-r} (\varphi_r s^r + \dots + \varphi_0 \prod_{i=1}^{n-r} (s - \sigma_i)).$$

From the construction of the  $\sigma_i$  we have that 0 is not a root of  $\varphi_r(\omega)s^r + \dots + \varphi_0(\omega)$  so  $\varphi_0(\omega) \neq 0$  for any  $\omega \in V_{n-r}$ . Let  $V = V_{n-r}$ .

Clearly,

$$f(\omega, s) = (\varphi_0(\omega)s^r + \dots + \varphi_r(\omega) \prod_{i=1}^{n-r} (s - \sigma_i(\omega))).$$

From the continuity of  $\varphi_i$  and  $\sigma_i$  it follows that there exist  $\lambda_1, \dots, \lambda_r : V \rightarrow C$ , continuous at  $\omega_0$  such that

$$\varphi_0(\omega)s^r + \dots + \varphi_r(\omega) = \varphi_0(\omega) \prod_{i=1}^r (s - \lambda_i(\omega))$$

for all  $\omega \in V$ . This completes the proof.

We thus have that the eigenvalues of the system (4.8) are  $\lambda_1(\omega), \dots, \lambda_r(\omega)$  and  $\frac{1}{\sigma_1(\omega)}, \dots, \frac{1}{\sigma_{n-r}(\omega)}$  where  $\lambda_i$  and  $\sigma_i$  are continuous at  $\omega_0$  and  $\sigma_i(\omega_0) = 0$ . Hence there is a characteristic separation of the modes of all systems of the form (4.8) according to magnitudes.

It is now a straightforward task to prove proposition 3.1.

Proof of Proposition 3.1. Let  $\Omega = X$  with the topology induced by the norm (3.20) and choose  $\omega_0 \in J$ . Then from lemma 4.3

$$\det(L_f s - I - B_f(\omega | F)) = \alpha(\omega) \left( \prod_{i=1}^p (s - \lambda_i(\omega)) \right) \left( \prod_{i=1}^{n-r-p} (\delta_i(\omega) s - 1) \right)$$

for some  $p \leq n-r$  where  $\alpha(\omega_0) \neq 0$  and  $\delta_i(\omega) = 0$ . Clearly,

$$\det(L_f s - I - B_f(\omega | F)) \neq 0$$

is satisfied throughout a neighborhood of  $\omega_0$ . Also

$$\bar{\eta}_i(\omega_0) \notin \sigma(E, A)$$

implies

$$\bar{\eta}_i(\omega) \notin \sigma(E, A)$$

throughout a neighborhood of  $\omega_0$ . Finally,

$$\frac{1}{\delta_i(\omega)} \notin \sigma(E, A)$$

so

$$\sigma(L_f, I + B_f(\omega | F)) \cap \sigma(E, A) = \emptyset$$

throughout some neighborhood of  $\omega_0$ . Hence  $J$  is open in  $\Omega$  and the proof is complete.

#### 4.3. Slow and Fast Subspaces

Since the system (4.8) is a descriptor system at  $\omega_0$ , the slow and fast subspaces are already defined at  $\omega_0$ . We shall now extend their definitions to a neighborhood of  $\omega_0$ . From lemma 4.3 there exists a neighborhood  $V$  of  $\omega_0$  such that  $|\lambda_i(\omega)| < \left| \frac{1}{\sigma_i(\omega)} \right|$  for all  $\omega \in V$ . We now re-define  $\Omega = V$  so that the natural eigenvalue separation occurs at all points of  $\Omega$ . Since we are concerned only with local properties of (4.8) about  $\omega_0$ , the restriction of  $\Omega$  to a neighborhood of  $\omega_0$  causes no problems.

To facilitate the definition of slow and fast subspaces we need the following lemma.

Lemma 4.4. Let  $E, A \in H_X(X)$  satisfy (4.9). Then there exists  $\lambda : \Omega \rightarrow \mathbb{C}$ , continuous at  $\omega_0$  such that  $\lambda(\omega) \in \mathbb{C} - \sigma(E(\omega), A(\omega))$  for all  $\omega \in \Omega$ .

Proof: Let  $\eta : \Omega \rightarrow \mathbb{C}$  be continuous at  $\omega_0$  with  $\eta(\omega_0) \notin \sigma(E(\omega_0), A(\omega_0))$ . Then there exists a neighborhood  $V$  of  $\omega_0$  such that  $\eta(\omega) \notin \lambda_i(\omega)$ ,  $i = 1, \dots, r$  and  $|\eta(\omega)| < \left| \frac{1}{\sigma_i(\omega)} \right|$ ,  $i = 1, \dots, n-r$ . Hence  $\eta(\omega) \notin \sigma(E(\omega), A(\omega))$  for all  $\omega \in V$ . Define  $\lambda(\omega) = \eta(\omega)$  for  $\omega \in V$  and let  $\lambda(\omega)$  satisfy  $\lambda(\omega) \notin \sigma(E(\omega), A(\omega))$  for  $\omega \in \Omega - V$ . This completes the proof.

Choosing  $\lambda$  as in lemma 4.4 we may now define the slow subspace at  $\omega$  as

$$S(\omega) = \text{Ker} \prod_{i=1}^r ((\lambda(\omega)E(\omega) - A(\omega))^{-1} E(\omega) - \frac{1}{\lambda(\omega) - \lambda_i(\omega)} I) \quad (4.13)$$

and the fast subspace at  $\omega$  as

$$F(\omega) = \text{Ker} \prod_{i=1}^{n-r} ((\lambda(\omega)E(\omega) - A(\omega))^{-1} E(\omega) - \frac{\sigma_i(\omega)}{\lambda(\omega)\sigma_i(\omega) - 1} I). \quad (4.14)$$

Let

$$\det(Is - (\lambda(\omega)E(\omega) - A(\omega))^{-1} E(\omega)) = \prod_{i=1}^{p_\omega} (s - \eta_{i\omega})^{n_{i\omega}} \quad (4.15)$$

with  $i \neq j$  implying  $\eta_{i\omega} \neq \eta_{j\omega}$ . As demonstrated in the proof of theorem 2.1,  $\frac{1}{\lambda(\omega) - \lambda_i(\omega)}$  is an eigenvalue of  $(\lambda(\omega)E(\omega) - A(\omega))^{-1} E(\omega)$  and so may be identified, after proper indexing with  $\eta_{i\omega}$ ,  $i = 1, \dots, q_\omega$  for some  $q_\omega$ . The remaining eigenvalues of  $(\lambda(\omega)E(\omega) - A(\omega))^{-1} E(\omega)$  are  $\frac{\sigma_i(\omega)}{\lambda(\omega)\sigma_i(\omega) - 1}$  and may be identified with  $\eta_{i\omega}$ ,  $i = q_\omega + 1, \dots, p_\omega$ . Hence we may give an alternate definition of  $S(\omega)$  and  $F(\omega)$  as the direct sum of eigenspaces. Note the resemblance to (2.7) and (2.8).

$$S(\omega) = \bigoplus_{i=1}^{q_\omega} \text{Ker}((\lambda(\omega)E(\omega) - A(\omega))^{-1} E(\omega) - \eta_{i\omega} I)^{n_{i\omega}} \quad (4.16)$$

$$F(\omega) = \bigoplus_{i=q_\omega+1}^{p_\omega} \text{Ker}((\lambda(\omega)E(\omega) - A(\omega))^{-1} E(\omega) - \eta_{i\omega} I)^{n_{i\omega}} \quad (4.17)$$

Clearly, the definitions (4.16) and (4.17) are equivalent to (4.14) and (4.15). (4.14) and (4.15) are usually to be preferred, however, since they are given in terms of operators that vary continuously with  $\omega$  at  $\omega_0$ . It follows immediately from lemma 2.1 that  $S(\omega)$  and  $F(\omega)$  are independent of the particular choice of the function  $\lambda$  for all  $\omega \in \Omega$ . From the definitions and the properties of  $\lambda_i$  and  $\sigma_i$  as outlined in lemma 4.3 it is clear that  $\dim S(\omega) = r$  and  $\dim F(\omega) = n-r$  for all  $\omega$ . Also,  $S(\omega) \oplus F(\omega) = X$  for all  $\omega$ . From (4.13), (4.14), and lemma 4.2 we have that  $S, F : \Omega \rightarrow \mathcal{M}$  are continuous at  $\omega_0$ .

#### 4.4. System Decomposition

We now extend the decomposition for descriptor systems to a neighborhood of the singular point. We first extend the algorithm (2.10) - (2.13) to all of  $\Omega$ . Let  $J_1, J_2 : \Omega \rightarrow \mathcal{X}$  be defined by

$$J_1(\omega) = (\lambda(\omega)E(\omega) - A(\omega))^{-1}E(\omega) \mid S(\omega) \quad (4.18)$$

$$J_2(\omega) = (\lambda(\omega)E(\omega) - A(\omega))^{-1}E(\omega) \mid F(\omega). \quad (4.19)$$

Define  $\bar{M}, M : \Omega \rightarrow \text{Hom}(X, X)$  by

$$\bar{M}(\omega)x = \begin{cases} J_1(\omega)^{-1}x & \text{if } x \in S(\omega) \\ (\lambda(\omega)J_2(\omega) - I)^{-1}x & \text{if } x \in F(\omega) \end{cases} \quad (4.20)$$

and

$$M(\omega) = \bar{M}(\omega) (\lambda(\omega)E(\omega) - A(\omega))^{-1}. \quad (4.21)$$

Finally, let  $L_s, L_f : \Omega \rightarrow \mathcal{X}$  be given by

$$L_s(\omega) = \lambda(\omega)I - J_1(\omega)^{-1} \quad (4.22)$$

and

$$L_f(\omega) = (\lambda(\omega)J_2(\omega) - I)^{-1}J_2(\omega). \quad (4.23)$$

Clearly,  $\bar{M}(\omega)$  and  $M(\omega)$  are invertible for each  $\omega \in \Omega$ . From proposition 4.1 we have  $J_1, L_s \in H_S(X)$ ,  $J_2, L_f \in H_F(X)$ , and  $\bar{M}, M \in H_X(X)$ .

At this point we are ready to state the main decomposition result.

**Theorem 4.1.** For each  $\omega \in \Omega$

- 1)  $S(\omega)$  and  $F(\omega)$  are both  $M(\omega)E(\omega)$ - and  $M(\omega)A(\omega)$ -invariant.
- 2)  $M(\omega)E(\omega) \mid S(\omega) = I$ ,  $M(\omega)A(\omega) \mid F(\omega) = I$ .
- 3)  $M(\omega)E(\omega) \mid F(\omega) = L_f(\omega)$ ,  $M(\omega)A(\omega) \mid S(\omega) = L_s(\omega)$ .
- 4)  $\det(L_f(\omega)s - I) = \prod_{i=1}^{n-r} (\sigma_i(\omega)s - 1)$ .
- 5)  $\det(Is - L_s(\omega)) = \prod_{i=1}^r (s - \lambda_i(\omega))$ .

**Proof:** 1) - 3) follow immediately from the definitions and from

$$(\lambda(\omega)E(\omega) - A(\omega))^{-1}A(\omega) = \lambda(\omega) (\lambda(\omega)E(\omega) - A(\omega))^{-1}E(\omega) - I.$$

To prove 4) note that

$$\det(Is - J_2(\omega)) = \prod_{i=1}^{n-r} \left( s - \frac{\sigma_i(\omega)}{\lambda(\omega)\sigma_i(\omega) - 1} \right).$$

Then from (4.23) we have the desired result. 5) follows similarly by

observing that

$$\det(Is - J_1(\omega)) = \prod_{i=1}^r \left( s - \frac{1}{\lambda(\omega) - \lambda_i(\omega)} \right).$$

This completes the proof.

From lemma 2.2,  $M$  is independent of  $\lambda$  and hence so are  $L_s$  and  $L_f$ . From 6) of proposition 4.1 we may define  $B_s \in H_S(U)$  and  $B_f \in H_F(U)$  according to



$$B_s(\omega) = P_{S(\omega)} F(\omega) B(\omega) \quad (4.24)$$

and

$$B_f(\omega) = P_{F(\omega)} S(\omega) B(\omega). \quad (4.25)$$

We have finally arrived at the decoupled system equivalent to (4.8). Letting the solution  $x$  of (4.8) be decomposed by  $S(\omega)$  and  $F(\omega)$  into  $x = x_s + x_f$  we define the slow subsystem

$$\dot{x}_s = L_s(\omega)x_s + B_s(\omega)u \quad (4.26)$$

and the fast subsystem

$$L_f(\omega)\dot{x}_f = x_f + B_f(\omega)u. \quad (4.27)$$

The initial condition  $x_0$  is decomposed into

$$x_{s0}(\omega) = P_{S(\omega)} F(\omega) x_0 \quad (4.28)$$

and

$$x_{f0}(\omega) = P_{F(\omega)} S(\omega) x_0. \quad (4.29)$$

From 5) of proposition 4.1,  $x_{s0}$  and  $x_{f0}$  are continuous at  $\omega_0$ .

We have thus achieved an exact decoupling of (4.8) according to eigenvalue magnitudes. Continuity at the singular point has been preserved everywhere possible. The decomposition at  $\omega_0$  coincides with the descriptor decomposition developed in Chapter 2. We shall use the decoupling results in a variety of situations in later chapters.

## CHAPTER 5

## TRAJECTORY CONVERGENCE

5.1. Solution of Descriptor Equations

In this chapter we shall consider two questions. The first concerns one justification for calling (2.24) the solution of (2.20). Consider the class of all singularly perturbed systems whose system operators converge to those of a given descriptor system. Given one member of that class, its solution may or may not converge as  $\omega \rightarrow \omega_0$ . We would like to find the set of all possible limiting solutions of such systems. If there exists only one possible limit then it would make sense to call that the solution of the descriptor equation. Since each descriptor system is the limit of a singularly perturbed system, it would be convenient if at least the possibility of convergence of solutions existed. Of course we have to decide what definition of convergence of functions to use. It would be helpful if more than one notion of convergence gave the same result. So far no other author has taken such an approach to the solution of (2.20).

The second problem is that of determining when the solution of a singularly perturbed system does converge. More will be said about this later.

We first consider generalized functions (see [24]) from  $[0, \infty)$  into  $X$  and  $U$ . Let  $K(X)$  be the  $C$ -vector space of infinitely differentiable maps from  $(-\infty, \infty)$  into  $X$  having compact support. A sequence  $(\phi_k)$  in  $K(X)$  converges to  $\phi \in K(X)$  if and only if the supports of all the  $\phi_k$  are contained in the same bounded interval and  $\phi_k^i \rightarrow \phi^i$  uniformly for  $i = 1, 2, 3, \dots$ . The class of generalized functions is the set of all continuous linear functionals on  $K(X)$ . We shall consider only a subspace  $\mathcal{D}_0(X)$  of the generalized

functions.  $\mathcal{D}_0(X)$  consists of all  $x$  with  $(x, \varphi) = 0$  whenever  $\varphi$  has support contained in  $(-\infty, 0]$ . In other words,  $\mathcal{D}_0(X)$  consists of all  $x$  such that  $x = 0$  on  $(-\infty, 0)$ .

If  $x : [0, \infty) \rightarrow X$  is Lebesgue measurable and integrable on any compact interval then

$$(x, \varphi) = \int_0^{\infty} \langle x(t), \varphi(t) \rangle dt \quad (5.1)$$

defines the corresponding  $x \in \mathcal{D}_0(X)$ . For  $v \in X$ , the functional  $\delta^i v$  defined by

$$(\delta^i v, \varphi) = (-1)^i \langle v, \varphi^i(0) \rangle \quad (5.2)$$

is the multivariable generalization of the Dirac delta (differentiated  $i$  times). We shall consider the two most common topologies on  $\mathcal{D}_0(X)$ , the weak and strong topologies (see [24]). A sequence  $(x_k)$  in  $\mathcal{D}_0(X)$  is said to converge weakly to  $x \in \mathcal{D}_0(X)$  if  $(x_k, \varphi) \rightarrow (x, \varphi)$  for every  $\varphi \in K(X)$ . We need not even consider the definition of strong convergence. For our purposes it suffices to state that strong convergence implies weak convergence and the two limits are equal<sup>1</sup>.

Consider the descriptor variable system (2.5) and the class of all singularly perturbed systems converging to it in the sense of its defining operators. We could attempt to show that there is only one limit for the solution to achieve, but we are already satisfied with the definition of the solution of the slow subsystem (since this is merely a state equation). In fact, only the natural response of the fast subsystem is in question since the forced response is the solution of (2.20) in the ordinary sense for  $u \in C^q(U)$ . We especially need to justify our use of the unforced

<sup>1</sup>The three topologies on  $K(X)$  and  $\mathcal{D}_0(X)$  are all Hausdorff and satisfy the first axiom of countability. Hence, we need consider only countable sequences. Also, no sequence has more than one limit.

part of (2.24) since it does not even satisfy (2.20).

Let  $R_k \rightarrow R \in \mathcal{M}$  and  $(T_k)$  be in  $\mathcal{Z}$  with  $T_k$  invertible in  $\text{Hom}(R_k, R_k)$  and  $T_k \rightarrow T \in \text{Hom}(R, R)$ ,  $T$  nilpotent with index  $q$ . Let  $v_k \rightarrow v \in R$ . We need to consider the solution of

$$T_k \dot{x} = x \quad (5.3)$$

with initial condition  $v_k$ .

**Theorem 5.1.** If  $e(T_k^{-1})v_k$  converges weakly to some limit then that limit is  $\sum_{i=1}^{q-1} \delta^{i-1} T^i v$ .

**Proof:** We have for  $\varphi \in K(X)$

$$\begin{aligned} (e(T_k^{-1})v_k, \varphi) &= \int_0^\infty \langle e^{tT_k^{-1}} v_k, \varphi(t) \rangle dt = \sum_{i=1}^q (-1)^i \langle T_k^i v_k, \varphi^{i-1}(0) \rangle \\ &\quad + (-1)^q \int_0^\infty \langle T_k^q e^{tT_k^{-1}} v_k, \varphi^q(t) \rangle dt \end{aligned}$$

by integration by parts. Choose an orthonormal basis  $(e_1, \dots, e_n)$  of  $X$  and let

$$e^{tT_k^{-1}} v_k = \alpha_{1k}(t)e_1 + \dots + \alpha_{nk}(t)e_n$$

$$\varphi^q(t) = \beta_1(t)e_1 + \dots + \beta_n(t)e_n$$

$$\mu(T_k^q)e_j = \eta_{1jk}e_1 + \dots + \eta_{njk}e_n.$$

Since

$$\mu(T_k^q) = (\mu(T_k))^q,$$

$\mu(T_k^q) \rightarrow 0$  and  $\eta_{ijk} \rightarrow 0$  as  $k \rightarrow \infty$ . Since  $\varphi^q \in K(X)$ , we may define  $\psi_{ij} \in K(X)$  by

$$\psi_{ij}(t) = \beta_i(t)e_j.$$

Then

$$\int_0^{\infty} \alpha_{jk}(t) \beta(t) dt = \int_0^{\infty} \langle e^{tT_k^{-1}} v_k, \gamma_{ij}(t) \rangle dt = C_{ij}$$

for some  $C_{ij}$ ,  $i, j=1, \dots, n$  and

$$\begin{aligned} \int_0^{\infty} \langle T_k^q e^{tT_k^{-1}} v_k, \phi^q(t) \rangle dt &= \sum_{i=1}^n \int_0^{\infty} \langle \mu(T_k^q)(e^{tT_k^{-1}} v_k), \beta_i(t) e_i \rangle dt \\ &= \sum_{i,j=1}^n \eta_{ijk} \int_0^{\infty} \alpha_{jk}(t) \beta_i(t) dt = 0. \end{aligned}$$

Hence,

$$\langle e^{(T_k^{-1})v_k}, \phi \rangle - \sum_{i=1}^{q-1} (-1)^i \langle T^i v, \phi^{i-1}(0) \rangle = \left( - \sum_{i=1}^{q-1} \delta^{i-1} T^i v, \phi \right)$$

for all  $\phi \in K(X)$  and the proof is complete.

We therefore know that the only possible limit of the solution of the fast subsystem (4.27) (unforced) in the weak topology on  $\mathcal{D}_0(X)$  is in fact what we have been calling the solution all along. To reinforce this convergence argument, consider the strong topology on  $\mathcal{D}_0(X)$ . If the unforced solution of (4.27) converges in the strong sense then it must converge weakly. Since the two limits must be the same, Theorem 5.1 holds for strong convergence as well. The labeling of (2.24) as the "solution" of the fast subsystem is inescapable. It should be stressed, however, that (2.24) can be called the solution only in the limiting sense. Once again, it does not satisfy the equation (2.20).

## 5.2. Sufficient Conditions for Convergence

Although the previous section shows that only one limiting solution of a singularly perturbed system can exist, the question of whether or not that limit is actually achieved is still unanswered. In this section we shall develop conditions which guarantee convergence of the solution as  $\omega \rightarrow \omega_0$ .

For several reasons it is important to know if the system trajectory converges with  $\omega$ . Since in practice a descriptor system can usually be viewed as the limit of a particular singularly perturbed system, establishing trajectory convergence serves as justification for considering a descriptor system as a viable model. A descriptor system which has not been identified as the limit of a particular singularly perturbed system, or for which trajectory convergence has not been established may have hidden instability due to the disappearance of the fast modes in the limit.

In terms of numerical considerations, it is easier in some cases to compute the solution of an  $r$ th order descriptor system than an  $n$ th order state variable system. If trajectory convergence has been established, a computational savings may be obtained by setting the parameter to  $\omega_0$  and calculating the corresponding solution, sacrificing a small amount of accuracy.

Convergence of the solution of the standard system (1.5) is understood (see [20],[28], and [34]-[36]). Necessary and sufficient conditions for existence of a limiting solution can be stated in terms of the limiting system alone. This can be done, however, only because the assumption of the form (1.5) contains implicitly the assumption of one particular way of approaching the limiting system. In our formulation many different approaches are possible leading to a much more difficult problem. To guarantee convergence of solutions, some statements must be made not only about the limiting system, but also the way in which it is approached.

Convergence of the solution of the slow subsystem (4.26) in various senses is relatively easy to establish. We shall be concerned

mainly with characterizing convergence of the solution of the fast subsystem (4.27) in terms of the behavior of the fast eigenvalues  $\frac{1}{\sigma_i(\omega)}$ . For convenience we assume that  $L_f(\omega)$  is invertible when  $\omega \neq \omega_0$ . That is,  $\omega_0$  is an isolated singularity.

Let  $\Phi_f : \Omega \times [0, \infty) \times C^q(U) \times X \rightarrow X$  be given by

$$\Phi_f(\omega, t, u, x_0) = \begin{cases} e^{tL_f(\omega)^{-1}} x_{f0}(\omega) + \int_0^t e^{(t-\tau)L_f(\omega)^{-1}} B_f(\omega) u(\tau) d\tau & \text{if } \omega \neq \omega_0 \\ -\sum_{i=0}^{q-1} L_f(\omega_0)^i B_f(\omega_0) u^i(t) & \text{if } \omega = \omega_0 \end{cases} \quad (5.4)$$

where  $u^i(0)$  is the  $i$ th right-hand derivative of  $u$  at 0. Clearly,  $\Phi_f$  agrees on  $(0, \infty)$  with the solution of the fast part of (4.8) at  $\omega$  with control  $u$  and initial condition  $x_0$ .

From (5.4) it is clear that understanding the behavior of  $e(L_f(\omega)^{-1})$  plays an essential role in the study of  $\Phi_f$  convergence. We now characterize convergence of  $e(L_f(\omega)^{-1})$  in terms of the fast eigenvalues  $\frac{1}{\sigma_j(\omega)}$ .

Consider the smallest rectangle in  $C$ , symmetric about the real axis, enclosing the eigenvalues  $\frac{1}{\sigma_j(\omega)}$ . (See Figure 5.1.) Let

$$a(\omega) = \max_j \operatorname{Re} \frac{1}{\sigma_j(\omega)} \quad (5.5)$$

$$b(\omega) = \min_j \operatorname{Re} \frac{1}{\sigma_j(\omega)} \quad (5.6)$$

$$c(\omega) = \max_j \left| \operatorname{Im} \frac{1}{\sigma_j(\omega)} \right|^2. \quad (5.7)$$

Define

<sup>2</sup>Here "Im" denotes imaginary part.

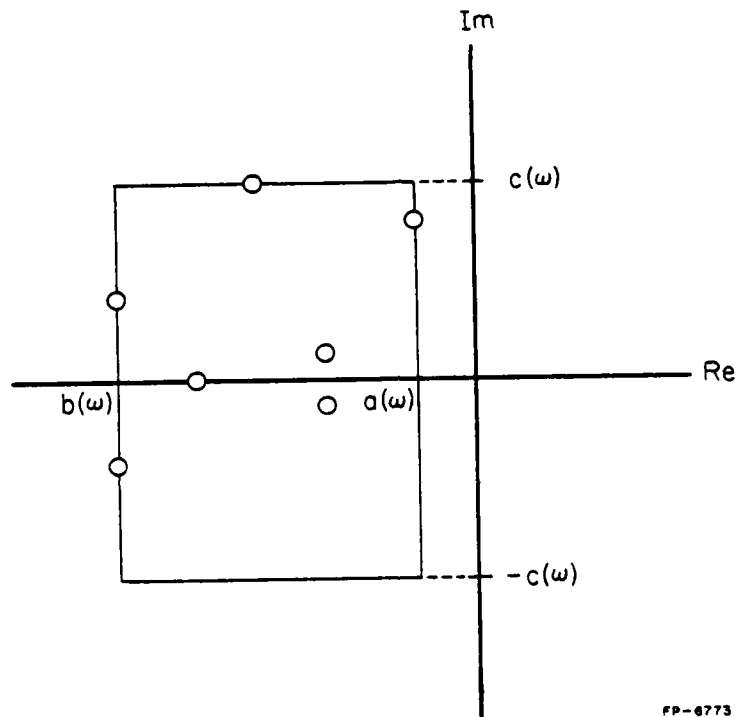

FP-6773

Figure 5.1. The eigenvalues of  $L_F^{-1}(\omega)$ .



$$\gamma(\omega) = \min\left\{ \frac{|a(\omega)|}{a(\omega)^2 + c(\omega)^2}, \frac{|b(\omega)|}{b(\omega)^2 + c(\omega)^2} \right\}. \quad (5.8)$$

As a part of any sufficient condition for convergence that we shall derive, it will always be assumed that  $a(\omega) \rightarrow -\infty$  as  $\omega \rightarrow \omega_0$  and hence  $b(\omega) \rightarrow -\infty$ . Actually, it can be shown that this is in fact necessary for most types of convergence. Thus we may restrict attention to a neighborhood  $V_1$  of  $\omega_0$  with  $\omega \in V_1 - \{\omega_0\}$  implying  $a(\omega) < 0$ . Define  $p_\omega : [0, 1] \rightarrow \mathbb{C}$  by

$$p_\omega(y) = \left| \frac{\gamma(\omega)}{2} + \frac{1}{a(\omega)} \right| e^{i2\pi y} - \left( \frac{\gamma(\omega)}{\Psi} + \frac{1}{a(\omega)} \right). \quad (5.9)$$

$p_\omega$  parametrizes a circle with center at  $\frac{\gamma(\omega)}{\Psi} + \frac{1}{a(\omega)}$  and radius  $\left| \frac{\gamma(\omega)}{2} + \frac{1}{a(\omega)} \right|$ .

Let  $p_\omega = \delta_\omega + i_1 i$ .

Lemma 5.1.  $\delta_\omega(y) < 0$ ,  $\sigma_j(\omega)$  is enclosed by  $p_\omega$ , and

$$|p_\omega(y) - \sigma_j(\omega)| \geq \frac{\gamma(\omega)}{\Psi}$$

for  $j=1, \dots, n-r$  and each  $y \in [0, 1]$ ,  $\omega \in V_1 - \{\omega_0\}$ .

Proof: Choose  $j, y$ , and  $\omega$ . We have

$$\gamma(\omega) \leq \frac{-a(\omega)}{a(\omega)^2 + c(\omega)^2} \leq -\frac{1}{a(\omega)}.$$

From (5.9),

$$\delta_\omega(y) \leq \frac{\gamma(\omega)}{4} < 0.$$

Let  $\sigma_j(\omega) = w + zi$ . Then

$$b(\omega) \leq \frac{w}{w^2 + z^2} \leq a(\omega)$$

and

$$\left| \frac{z}{w^2 + z^2} \right| \leq c(\omega).$$

Equivalently,

$$\begin{aligned}
 \left(w - \frac{1}{2a(w)}\right)^2 + z^2 &\leq \frac{1}{4a(w)^2} \\
 \left(w - \frac{1}{2b(w)}\right)^2 + z^2 &\geq \frac{1}{4b(w)^2} \\
 w^2 + \left(z - \frac{1}{2c(w)}\right)^2 &\geq \frac{1}{4c(w)^2} \\
 w^2 + \left(z + \frac{1}{2c(w)}\right)^2 &\geq \frac{1}{4c(w)^2}.
 \end{aligned} \tag{5.10}$$

Hence,  $\sigma_j(\omega)$  is contained in the region determined by four circles as in Figure 5.2. The five points of intersection are  $\frac{a(\omega) \pm c(\omega)i}{a(\omega)^2 + c(\omega)^2}$ ,  $\frac{b(\omega) \pm c(\omega)i}{b(\omega)^2 + c(\omega)^2}$ , 0. From the geometry it is clear that  $w \leq -Y(\omega)$ . From (5.10) it follows that

$$w^2 + z^2 \leq \frac{w}{a(\omega)}$$

so

$$\begin{aligned}
 \left(w - \frac{Y(\omega)}{4} - \frac{1}{a(\omega)}\right)^2 + z^2 &\leq -\left(\frac{Y(\omega)}{2} + \frac{1}{a(\omega)}\right)w + \left(\frac{Y(\omega)}{4} + \frac{1}{a(\omega)}\right)^2 \leq \frac{9Y(\omega)}{16} + \frac{3Y(\omega)}{2a(\omega)} + \frac{1}{a(\omega)^2} \\
 &= \left(\frac{3Y(\omega)}{4} + \frac{1}{a(\omega)}\right)^2.
 \end{aligned}$$

Thus,  $\sigma_j(\omega)$  is enclosed by the circle with center at  $\frac{Y(\omega)}{4} + \frac{1}{a(\omega)}$  and radius

$$\left|\frac{3Y(\omega)}{4} + \frac{1}{a(\omega)}\right| = \left|\frac{Y(\omega)}{2} + \frac{1}{a(\omega)}\right| - \frac{Y(\omega)}{4}$$

and the proof is complete.

**Lemma 5.2.** If  $a(\omega) \rightarrow \infty$ ,  $b(\omega)\varphi^{a(\omega)} \rightarrow 0$ , and  $c(\omega)\varphi^{a(\omega)} \rightarrow 0$  as  $\omega \rightarrow \omega_0$  for every  $\varphi > 1$  then  $e(L_f(\omega)^{-1}) \rightarrow 0$  pointwise on  $(0, \infty)$  and uniformly on  $[\epsilon, \infty)$  with respect to the pseudometric  $d_X$  (see (4.4)) for all  $\epsilon > 0$ .

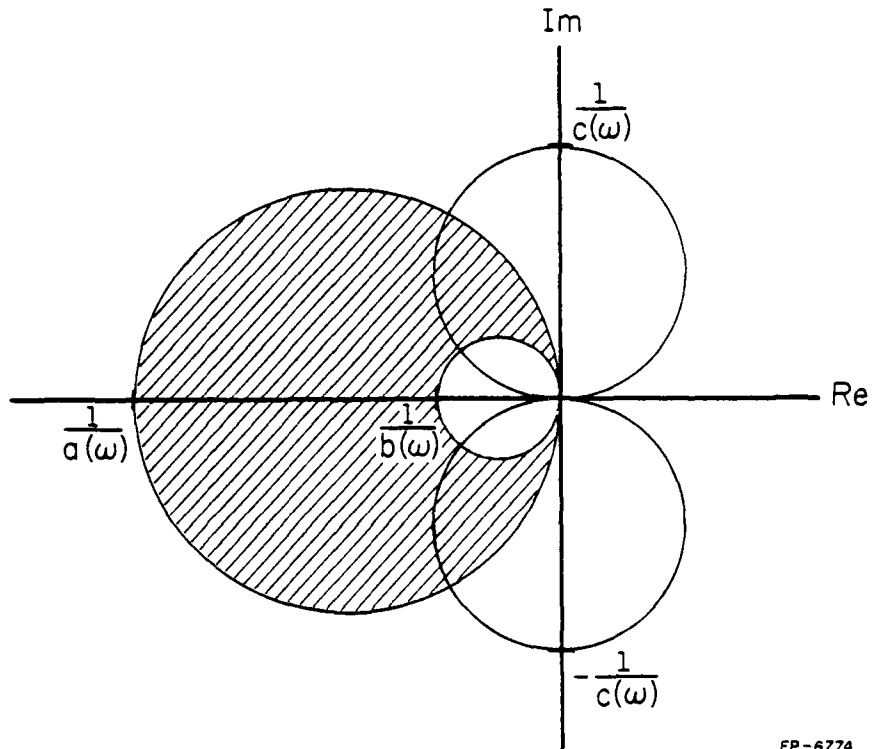

FP-6774

Figure 5.2. The region containing  $\sigma_j(\omega)$ .

Proof: Let  $t \geq \epsilon > 0$ . Then

$$e^{tL_f(\omega)^{-1}} = \frac{1}{2\pi i} \oint e^{\frac{t}{s}} (sI - L_f(\omega))^{-1} ds$$

where the path of integration is parameterized by  $p_\omega$ . Hence,

$$\begin{aligned} \|e^{tL_f(\omega)^{-1}}\| &= \frac{1}{2\pi} \int_0^1 \frac{e^{\frac{t}{p_\omega(y)}} |p'_\omega(y)|}{\prod_{j=1}^n |p_\omega(y) - \sigma_j(\omega)|} \| \text{adj}(p_\omega(y)I - L_f(\omega)) \| dy \\ &\leq \frac{1}{2\pi} \int_0^1 \frac{e^{\frac{t}{p_\omega(y)}} |p'_\omega(y)|}{\prod_{j=1}^n |p_\omega(y) - \sigma_j(\omega)|} \| \text{adj}(p_\omega(y)I - L_f(\omega)) \| dy \end{aligned}$$

where "adj" denotes the (classical) adjoint. Since  $p_\omega(y) \rightarrow 0$  as  $\omega \rightarrow \omega_0$  uniformly in  $y$ ,

$$\| \text{adj}(p_\omega(y)I - L_f(\omega)) \| \rightarrow \| \text{adj} L_f(\omega_0) \|$$

uniformly in  $y$  and there exists a neighborhood  $V$  of  $\omega_0$  and  $N > 0$  such that

$$\| \text{adj}(p_\omega(y)I - L_f(\omega)) \| < N$$

for all  $\omega \in V - \{\omega_0\}$ ,  $y \in [0, 1]$ .

We have for  $\omega \in V_1 - \{\omega_0\}$ ,

$$\left(\delta_\omega(y) - \frac{\gamma(\omega)}{4} - \frac{1}{a(\omega)}\right)^2 + \eta_\omega(y)^2 = \left(\frac{\gamma(\omega)}{2} + \frac{1}{a(\omega)}\right)^2 \leq \left(\frac{\gamma(\omega)}{4} + \frac{1}{a(\omega)}\right)^2$$

so

$$\frac{\delta_\omega(y)}{\delta_\omega(y)^2 + \eta_\omega(y)^2} \leq \frac{1}{2\left(\frac{\gamma(\omega)}{4} + \frac{1}{a(\omega)}\right)} \leq \frac{2}{3} a(\omega)$$

since  $\gamma(\omega) \leq \frac{1}{a(\omega)}$ . Thus

$$\left| \frac{t}{e^{p_w(y)}} \right| \leq e^{\frac{2}{3} \epsilon a(w)}.$$

From

$$|p'_w(y)| = 2\pi \left| \frac{\gamma(w)}{2} + \frac{1}{a(w)} \right|$$

it follows that for  $w \in V \cap V_1 - \{w_0\}$

$$\| \mu(e^{tL_f(w)})^{-1} \| \leq \frac{e^{\frac{2}{3} \epsilon a(w) \left( \frac{\gamma(w)}{2} + \frac{1}{a(w)} \right) \cdot N}}{\left( \frac{\gamma(w)}{4} \right)^{n-r}}$$

which is independent of  $t$ . If  $n-r=1$  we need only show that

$$\frac{e^{\frac{2}{3} \epsilon a(w)}}{a(w)\gamma(w)} \rightarrow 0.$$

Letting  $\varphi = e^{\frac{1}{3} \epsilon}$  we have

$$\frac{\varphi^{2a(w)}}{a(w) \left( \frac{a(w)}{a(w)^2 + c(w)^2} \right)} = \varphi^{2a(w)} + \frac{1}{a(w)^2} (c(w)\varphi^{a(w)})^2$$

and

$$\frac{\varphi^{2a(w)}}{a(w) \left( \frac{b(w)}{b(w)^2 + c(w)^2} \right)} \leq \frac{1}{a(w)^2} ((b(w)\varphi^{a(w)})^2 + (c(w)\varphi^{a(w)})^2).$$

For  $n-r > 1$  set  $\varphi = e^{\frac{1}{3(n-r-1)} \epsilon}$ . Then

$$\frac{e^{\frac{2}{3} \epsilon a(w)}}{\gamma(w)^{n-r-1}} = \left( \frac{\varphi^{2a(w)}}{\gamma(w)} \right)^{n-r-1}.$$

But

$$\frac{\varphi^{2a(w)}}{a(w) \left( \frac{a(w)}{a(w)^2 + c(w)^2} \right)} = a(w)\varphi^{2a(w)} + \frac{1}{a(w)} (c(w)\varphi^{a(w)})^2$$

and

$$\frac{\frac{\varphi^{2a(w)}}{b(w)}}{b(w)^2 + c(w)^2} = \frac{1}{b(w)} ((b(w)\varphi^{a(w)})^2 + (c(w)\varphi^{a(w)})^2).$$

Finally, setting  $\varphi = e^{\frac{\epsilon}{3(n-r)}}$  and applying similar arguments gives

$$\frac{\frac{2}{3} \epsilon a(w)}{a(w)\gamma(w)^{n-r}} \rightarrow 0.$$

This completes the proof.

Lemma 5.2 establishes convergence of the exponential provided  $a(w) \rightarrow -\infty$  and certain growth conditions on  $b(w)$  and  $c(w)$  are satisfied. For example, if

$$b(w) \leq N a(w)^k \quad (5.11)$$

for some  $N, k > 0$  then the condition  $b(w)\varphi^{a(w)} \rightarrow 0$  holds for every  $\varphi > 1$ . The rate of growth of  $b(w)$  and  $c(w)$  must be less than any exponential of  $a(w)$ .

Lemma 5.3. If  $a(w) \rightarrow -\infty$  then there exists a neighborhood  $V$  of  $w_0$  such that

$$\int_0^\infty \| e^{tL_f(w)^{-1}} \| dt < \left| \frac{b(w)^2 + c(w)^2}{a(w)} \right|^{n-r}$$

for all  $w \in V - \{w_0\}$ .

Proof: As in the proof of lemma 5.2,

$$\| e^{tL_f(w)^{-1}} \| \leq N \left( \frac{4}{\gamma(w)} \right)^{n-r} \left| \frac{\gamma(w)}{2} + \frac{1}{a(w)} \right| \int_0^1 \left| e^{\frac{t}{p_w(y)}} \right| dy$$

so, by Fubini's theorem,

$$\begin{aligned} \int_0^\infty \| e^{tL_f(w)^{-1}} \| dt &\leq N \left( \frac{4}{\gamma(w)} \right)^{n-r} \left| \frac{\gamma(w)}{2} + \frac{1}{a(w)} \right| \int_0^1 \int_0^\infty \left| e^{\frac{t}{p_w(y)}} \right| dt dy \\ &\leq N \left( \frac{4}{\gamma(w)} \right)^{n-r} \left( \frac{\gamma(w)}{2} + \frac{1}{a(w)} \right) \left( \frac{3}{2a(w)} \right) \leq \frac{3}{2} N \left( \frac{4}{\gamma(w)} \right)^{n-r} \left( \frac{1}{a(w)} \right)^2. \end{aligned}$$

Since  $a(\omega) \rightarrow -\infty$ , there exists a neighborhood  $V$  of  $\omega_0$  with

$$\left(\frac{1}{a(\omega)}\right)^2 < \frac{2}{3} \left(\frac{1}{4^{n-r} N}\right).$$

Then

$$\int_0^\infty \|e^{tL_f(\omega)^{-1}}\| dt < \left(\frac{1}{\gamma(\omega)}\right)^{n-r} \leq \left|\frac{b(\omega)^2 + c(\omega)^2}{a(\omega)}\right|^{n-r}$$

and the proof is complete.

We now establish sufficient conditions for convergence of  $\Phi_f$ .

**Theorem 5.2.** Let  $a(\omega) \rightarrow -\infty$ ,  $b(\omega)\phi^{a(\omega)} \rightarrow 0$ , and  $c(\omega)\phi^{a(\omega)} \rightarrow 0$  for every  $\phi > 1$  and let  $u \in C^\infty(U)$  have all its derivatives bounded. If there exists a neighborhood  $V$  of  $\omega_0$  and a positive integer  $p$  such that

$$\|L_f(\omega)^p\| < \left|\frac{a(\omega)}{b(\omega)^2 + c(\omega)^2}\right|^{n-r}$$

for all  $\omega \in V - \{\omega_0\}$ , then, as  $\omega \rightarrow \omega_0$ ,

$$\Phi_f(\omega, \cdot, u, x_0) \rightarrow \Phi_f(\omega_0, \cdot, u, x_0)$$

pointwise on  $(0, \infty)$  and uniformly on  $[\epsilon, \infty)$  for every  $\epsilon > 0$  and each  $x_0 \in X$ .

**Proof:** For  $\omega \neq \omega_0$ , integration by parts gives

$$\begin{aligned} \Phi_f(\omega, t, u, x_0) &= e^{tL_f(\omega)^{-1}} x_{f_0}(\omega) - \sum_{i=0}^p L_f(\omega)^i B_f(\omega) u^i(t) \\ &+ e^{tL_f(\omega)^{-1}} \sum_{i=0}^p L_f(\omega)^i B_f(\omega) u^i(0) + L_f(\omega)^p \int_0^t e^{(t-\tau)L_f(\omega)^{-1}} B_f(\omega) u^p(\tau) d\tau. \end{aligned}$$

From

$$\left|\frac{a(\omega)}{b(\omega)^2 + c(\omega)^2}\right| \leq \left|\frac{1}{b(\omega)}\right|$$

it follows that  $L_f(\omega)^p \rightarrow 0$  so  $p \geq q$ . Hence, from lemmas 5.2 and 5.3, the desired result follows.



## CHAPTER 6

## FURTHER STRUCTURAL PROPERTIES

6.1. Slow Subsystem

It is often advantageous to know that if a certain dynamical system property holds for a singularly perturbed system at  $\omega_0$ , then it also holds throughout some neighborhood of  $\omega_0$ . For example, in this chapter we shall see that controllability behaves in this way. Hence, controllability at  $\omega_0$  is sufficient to guarantee existence of the optimal solution of the LQ regulator problem (see Chapter 7) throughout a neighborhood of  $\omega_0$ . This fact will result in a computational savings.

In this chapter we shall consider various results of this type. Applications to the pole placement problem will be discussed.

In section 4.3 we restricted the parameter space  $\Omega$  to a neighborhood of  $\omega_0$  so that the eigenvalues of the system  $\lambda_i(\omega)$  and  $\frac{1}{\sigma_i(\omega)}$  are separated by magnitudes for all  $\omega \in \Omega$ . Since each  $\lambda_i$  is continuous at  $\omega_0$ , the parameter space can be further restricted so that  $\lambda_i(\omega_0) \neq \lambda_j(\omega_0)$  implies  $\lambda_i(\omega) \neq \lambda_j(\omega)$  for all  $\omega \in \Omega$ . Accordingly, the functions  $\lambda_i$  can be partitioned into equivalence classes,  $\lambda_i$  and  $\lambda_j$  being in the same class if and only if  $\lambda_i(\omega_0) = \lambda_j(\omega_0)$ . We can reindex the  $\lambda_i$  such that  $\lambda_1, \dots, \lambda_{n_1}$  comprise one equivalence class,  $\lambda_{n_1+1}, \dots, \lambda_{n_2}$  another, etc. up to  $n_k = r$ .

Consider the eigenspace

$$\begin{aligned} S_i(\omega) &= \text{Ker}_{j=n_{i-1}+1}^{\pi_i} \left( (\lambda(\omega)E(\omega) - A(\omega))^{-1} E(\omega) - \frac{1}{\lambda(\omega) - \lambda_j(\omega)} I \right) \\ &= \text{Ker}_{j=n_{i-1}+1}^{\pi_i} (L_s(\omega) - \lambda_j(\omega)I) \end{aligned} \quad (6.1)$$

where  $n_0 = 0$  and  $\lambda$  is as in lemma 4.4. From lemma 4.2 and the fact that  $S_i(\omega)$  has constant dimension throughout  $\Omega$  it follows that  $S_i$  is continuous at  $\omega_0$  for  $i = 1, \dots, k$ . Also,

$$S(\omega) = \bigoplus_{i=1}^k S_i(\omega). \quad (6.2)$$

**Lemma 6.1.** Let  $R_1, \dots, R_p : \Omega \rightarrow \mathcal{M}$  be continuous at  $\omega_0$ . Then there exists  $R : \Omega \rightarrow \mathcal{M}$  such that

- 1)  $R$  is continuous at  $\omega_0$ .
- 2)  $R(\omega) \subset R_1(\omega) + \dots + R_p(\omega) \quad \forall \omega \in \Omega$ .
- 3)  $R(\omega_0) = R_1(\omega_0) + \dots + R_p(\omega_0)$ .

**Proof:** Let  $L : \Omega \rightarrow \text{Hom}(X^p, X)$  be defined by

$$L(\omega)(x_1, \dots, x_p) = P_{R_1(\omega)} x_1 + \dots + P_{R_p(\omega)} x_p.$$

Then  $\omega \rightarrow L(\omega)^*$  is continuous at  $\omega_0$  and by lemma 4.2 there exists  $\bar{R} : \Omega \rightarrow \mathcal{M}$ , continuous at  $\omega_0$ , with  $\bar{R}(\omega) \supset \text{Ker } L(\omega)^*$  for all  $\omega \in \Omega$  and  $\bar{R}(\omega_0) = \text{Ker } L(\omega_0)^*$ . Let  $R(\omega) = \bar{R}(\omega)^\perp$ . Then  $R$  is continuous at  $\omega_0$ ,

$$R(\omega) \subset \text{Ker } L(\omega)^{\perp*} = R_1(\omega_0) + \dots + R_p(\omega_0).$$

This completes the proof.

Since  $\lambda_j$  is continuous at  $\omega_0$ ,  $\text{Re } \lambda_j(\omega_0) < 0$  implies that  $\text{Re } \lambda_j(\omega) < 0$  throughout some neighborhood of  $\omega_0$ . Let  $\lambda_{i_1}(\omega_0), \dots, \lambda_{i_p}(\omega_0)$  be the stable members of  $\sigma(E(\omega_0), A(\omega_0))$ . Continuity at  $\omega_0$  of  $S_i$  and lemma 6.1 give the following result.

**Proposition 6.1.** Let  $\Delta(\omega)$  be the eigenspace corresponding to the stable eigenvalues of the system (4.8). Then  $\omega \rightarrow \bigoplus_{j=1}^p S_{i_j}(\omega)$  is continuous at  $\omega_0$  and there exists a neighborhood  $V$  of  $\omega_0$  such that  $\bigoplus_{j=1}^p S_{i_j}(\omega) \subset \Delta(\omega)$  for

every  $\omega \in V$ .

Proposition 6.1 states that for small perturbations the slow subsystem is at least as stable when perturbed as it is at  $\omega_0$ . Also, the stable subspace is well-behaved about  $\omega_0$ .

We next consider the controllable subspace  $\mathcal{R}_s(\omega)$  of the slow subsystem (4.26).

Proposition 6.2. There exists  $R : \Omega \rightarrow \mathcal{M}$  such that

- 1)  $R$  is continuous at  $\omega_0$ .
- 2)  $R(\omega) \subset \mathcal{R}_s(\omega) \quad \forall \omega \in \Omega$ .
- 3)  $R(\omega_0) = \mathcal{R}_s(\omega_0)$ .

Proof: Since

$$\nu(L_s(\omega) \overset{i}{B}_s(\omega)) = \nu(L_s(\omega) \overset{i}{\nu}(B_s(\omega))),$$

$\omega \rightarrow \nu(L_s(\omega) \overset{i}{B}_s(\omega))^*$  is continuous at  $\omega_0$ . Hence, from lemma 4.2 there exists  $R_i : \Omega \rightarrow \mathcal{M}$ , continuous at  $\omega_0$ , with  $R_i(\omega) \subset \text{Im}(L_s(\omega) \overset{i}{B}_s(\omega))$  for all  $\omega \in \Omega$  and  $R_i(\omega_0) = \text{Im}(L_s(\omega_0) \overset{i}{B}_s(\omega_0))$ . Let  $R$  be as in lemma 6.1 with  $p = r$ . Then 1) holds and

$$\begin{aligned} R(\omega) \subset R_1(\omega) + \dots + R_r(\omega) &\subset \text{Im} B_s(\omega) + \text{Im}(L_s(\omega) B_s(\omega)) + \dots + \text{Im}(L_s(\omega) \overset{r}{B}_s(\omega)) \\ &= \mathcal{R}_s(\omega) \end{aligned}$$

for all  $\omega \in \Omega$  so 2) holds. 3) follows similarly. This completes the proof.

Thus, the slow subsystem is at least as controllable when perturbed as it is at  $\omega_0$ . The slow controllable subspace is well-behaved about  $\omega_0$ .

To conclude this section we consider stabilizability.

Proposition 6.3. If  $\lambda_i(\omega_0)$  is a controllable mode then  $\lambda_i(\omega)$  is controllable throughout some neighborhood of  $\omega_0$ .

Proof: By hypothesis,

$$\text{Im}(\lambda_i(\omega_0)I - L_s(\omega_0)) + \text{Im} B_s(\omega_0) = S(\omega_0).$$

From proposition 4.1 and lemma 4.2 there exist  $R_1, R_2 : \Omega \rightarrow \mathcal{M}$ , continuous at  $\omega_0$ , with

$$R_1(\omega) \subset \text{Im} (\lambda_i(\omega)I - L_s(\omega))$$

and

$$R_2(\omega) \subset \text{Im } \nu(B_s(\omega))$$

for all  $\omega \in \Omega$  and such that

$$R_1(\omega_0) + R_2(\omega_0) = S(\omega_0).$$

From lemma 6.1 and the constant dimensionality of  $S$ ,

$$\text{Im} (\lambda_i(\omega)I - L_s(\omega)) + \text{Im } \nu(B_s(\omega)) = X$$

throughout a neighborhood of  $\Omega$  and the proof is complete.

Corollary: If the slow subsystem is stabilizable at  $\omega_0$  then it is stabilizable throughout some neighborhood of  $\omega_0$ .

## 6.2. Fast Subsystem

Since many different singularly perturbed systems, with various types of fast mode behavior, share the same limiting descriptor system, no information concerning stability of the perturbed fast subsystem can be extracted from the fast subsystem at the singular point. Hence, we cannot make statements analogous to those of the previous section about stabiliz-

ability and convergence of the stable eigenspaces. However, we can describe behavior of the controllable subspace.

Let  $\mathcal{R}_f(\omega)$  be the controllable subspace of the fast subsystem (4.27). If  $L_f(\omega)$  is not invertible at a certain  $\omega$ , then (4.27) must be decoupled according to the descriptor system decomposition outlined in Chapter 2. The resulting slow and fast subsystems (subsystems of (4.27)) then have well-defined controllable subspaces as given in Chapter 3. The vector sum of the slow and fast controllable subspaces is then the controllable subspace of (4.27).

Proposition 6.4. There exists  $R: \Omega \rightarrow \mathcal{M}$  such that

- 1)  $R$  is continuous at  $\omega_0$ .
- 2)  $R(\omega) \subset \mathcal{R}_f(\omega) \quad \forall \omega \in \Omega$ .
- 3)  $R(\omega_0) = \mathcal{R}_f(\omega_0)$ .

Proof: Choosing an arbitrary  $\omega \in \Omega$  and proceeding according to the algorithm (2.10) - (2.14) yields the decomposition  $F_1 \oplus F_2 = F(\omega)$  with

$$L_f(\omega) \big|_{F_1} = L_1$$

and

$$L_f(\omega) \big|_{F_2} = L_2$$

where  $L_1$  is invertible and  $L_2$  is nilpotent. In fact, the system decomposition takes the form

$$\dot{x}_1 = L_1^{-1} x_1 + L_1^{-1} B_1 u$$

$$L_2 \dot{x}_2 = x_2 + B_2 u$$

where  $B_1 = P_{F_1 F_2} B_f(\omega)$  and  $B_2 = P_{F_2 F_1} B_f(\omega)$ . The part of the controllable subspace corresponding to subsystem 1 is

$$\begin{aligned}\mathcal{R}_1 &= \text{Im}(L_1^{-1}B_1) + \dots + \text{Im}(L_1^{r-n}B_1) = L_1^{r-n}(\text{Im} B_1 + \dots + L_1^{n-r-1}\text{Im} B_1) \\ &= \text{Im} B_1 + \dots + L_1^{n-r-1}\text{Im} B_1\end{aligned}$$

by the Cayley - Hamilton theorem and the  $L_1$  - invariance of  $\mathcal{R}_1$ . Corresponding to subsystem 2 we have

$$\mathcal{R}_2 = \text{Im} B_2 + \dots + L_2^{n-r-1}\text{Im} B_2.$$

Thus,

$$\begin{aligned}\mathcal{R}_f(\omega) &= \mathcal{R}_1 \oplus \mathcal{R}_2 \\ &= \text{Im} B_f(\omega) + \dots + L_f(\omega)^{n-r-1}\text{Im} B_f(\omega).\end{aligned}$$

The result follows from lemmas 4.2 and 6.1. This completes the proof.

It is gratifying to note that we have defined controllability for descriptor systems in such a way that controllability at  $\omega_0$  implies controllability throughout a neighborhood of  $\omega_0$ .

### 6.3. Application to Pole Placement

From propositions 6.2 and 6.4 and lemma 6.1 it follows that statements identical to those in propositions 6.2 and 6.4 hold for  $\mathcal{R}(\omega) = \mathcal{R}_s(\omega) \oplus \mathcal{R}_f(\omega)$ . As an application of this and the results of the previous two sections we now show how some modes of the perturbed system can be placed approximately by designing a feedback gain for the system at  $\omega_0$ . Here we are generalizing results of [16].

First, since controllability at  $\omega_0$  implies controllability for small perturbations, the existence of a feedback gain that achieves arbitrary eigenvalue assignment in the perturbed system can in some cases be established by testing the system at  $\omega_0$  for controllability. If a mode

of the limiting system is controllable and if it is shifted as desired by linear feedback then, from local continuity of slow eigenvalues, the same feedback gain applied to the perturbed system results in eigenvalues only slightly different from those desired. Hence, for small perturbations, modes controllable at  $\omega_0$  can be approximately assigned as desired by considering only the limiting descriptor system.

In fact, as outlined in section 3.5, given a certain degree of controllability of the limiting system, a feedback gain may be constructed such that the closed-loop system at  $\omega_0$  has slow subsystem (in the descriptor sense) of dimension rank  $E(\omega_0)$  with all modes controllable. These can be assigned with linear feedback yielding an approximate assignment in the perturbed system. Unfortunately, this is the best that we can do. All information about the position of the remaining  $n$ -rank  $E(\omega_0)$  eigenvalues of the perturbed system is lost at  $\omega_0$ . In order to place the remaining eigenvalues, the subsystem decomposition must be calculated at the perturbed value of  $\omega$  and the gain calculated accordingly. Nevertheless, some computational convenience is achieved since the feedback gains may be calculated for the slow and fast subsystems individually. The modal separation eliminates some of the problems associated with stiff numerical computations.

## CHAPTER 7

## THE LINEAR QUADRATIC REGULATOR

7.1. Preliminaries

In this chapter we consider the optimal control problem with quadratic cost and singularly perturbed system constraint. A similar problem pertaining to the standard system (1.5) was considered in [15]. We shall need to solve the regulator problem for the descriptor system at  $\omega_0$ . The LQ regulator has been considered in [10] for descriptor systems using dynamic programming, but we shall take a Hilbert space approach. The Hilbert space methodology is more suitable for dealing with questions about convergence of the optimal control with respect to  $\omega$ .

Let  $L^2(X)$  be the set of Lebesgue measurable maps  $x : [0, \infty) \rightarrow X$  satisfying

$$\int_0^{\infty} \|x(t)\|^2 dt < \infty. \quad (7.1)$$

After identifying functions which are equal almost everywhere,  $L^2(X)$  is a Hilbert space with inner product defined by

$$\langle x, y \rangle = \int_0^{\infty} \langle x(t), y(t) \rangle dt \quad (7.2)$$

for all  $x, y \in L^2(X)$ . Define  $L^2(U)$  similarly.  $L^2(X) \times L^2(U)$  is also a Hilbert space with inner product

$$\langle (x, u), (y, v) \rangle = \langle x, y \rangle + \langle u, v \rangle. \quad (7.3)$$

Recall the definition (2.21) of  $e(T)$  for  $T \in \text{Hom}(X, X)$ . For  $x \in L^2(X)$  it is known (see [22], p. 158) that if  $T$  is stable then the convolution  $e(T) * x : [0, \infty) \rightarrow X$  belongs to  $L^2(X)$  and



$$\|e(T)*x\| \leq \|x\| \int_0^{\infty} \|e^{tT}\| dt < \infty. \quad (7.4)$$

Throughout this chapter we shall consider only singularly perturbed systems with  $L_f(\omega_0) = 0$ ,  $L_f(\omega)$  invertible for  $\omega \neq \omega_0$ , and  $L_s(\omega_0)$  stable. We further assume that  $L_f(\omega)$  is stable for  $\omega \neq \omega_0$ . Hence,  $\eta_\omega : [0, \infty) \rightarrow X$  defined by

$$\eta_\omega(t) = \begin{cases} e^{tL_s(\omega)} x_{s0}(\omega) + e^{tL_f(\omega)^{-1}} x_{f0}(\omega) & \text{if } \omega \neq \omega_0 \\ e^{tL_s(\omega_0)} x_{s0}(\omega_0) & \text{if } \omega = \omega_0 \end{cases} \quad (7.5)$$

is in  $L^2(X)$  for  $\omega$  in some neighborhood of  $\omega_0$ . We now restrict  $\Omega$  to a neighborhood of  $\omega_0$  such that  $\eta_\omega \in L^2(X)$  for all  $\omega \in \Omega$ . Clearly,  $\eta_\omega$  is the natural response of (4.8).

If we define  $\mathcal{J}_\omega : L^2(U) \rightarrow L^2(X)$  by

$$\mathcal{J}_\omega(u) = \begin{cases} e(L_s(\omega)) * B_s(\omega)u + e(L_f(\omega)^{-1}) * L_f(\omega)^{-1} B_f(\omega)u & \text{if } \omega \neq \omega_0 \\ e(L_s(\omega_0)) * B_s(\omega_0)u - B_f(\omega_0)u & \text{if } \omega = \omega_0. \end{cases} \quad (7.6)$$

then  $\mathcal{J}_\omega(u)$  is the forced response of (4.8).

## 7.2. Problem Formulation

Let

$$\Lambda(\omega) = \{(x, u) \in L^2(X) \times L^2(U) \mid x = \mathcal{J}_\omega(u)\}. \quad (7.7)$$

Since  $\mathcal{J}_\omega$  is a linear map,  $\Lambda(\omega)$  is a subspace of  $L^2(X) \times L^2(U)$ . In fact, from (7.4) it follows that  $\mathcal{J}_\omega$  is continuous so  $\Lambda(\omega)$  is closed for all  $\omega \in \Omega$ . The solution of the regulator problem minimizes the cost functional

$$J(x,u) = \int_0^{\infty} \|x(t)\|^2 + \|u(t)\|^2 dt \quad (7.8)$$

over the constraint set  $(\eta_w, 0) + \Lambda(\omega)$  for each  $\omega \in \Omega$ . Since  $J(x,u) = \|(x,u)\|^2$ , we can view the problem as a minimum norm problem in  $L^2(X) \times L^2(U)$ . Since  $\Lambda(\omega)$  is closed, we have from the projection theorem (see [23]) that a unique pair  $(x_w, u_w) \in (\eta_w, 0) + \Lambda(\omega)$  that minimizes  $J$  exists for each  $\omega \in \Omega$ . Furthermore,

$$(x_w, u_w) = (\eta_w, 0) - P_{\Lambda(\omega)}(\eta_w, 0) \quad (7.9)$$

where  $P_{\Lambda(\omega)}$  is the orthogonal projection operator on  $\Lambda(\omega)$ .

The problem that this chapter addresses is not that of finding explicitly the solution of the regulator problem since this has already been done via the algebraic Riccati equation. The Riccati equation will not come into consideration to any significant extent in this chapter. The problem that we shall consider can be dealt with much more simply from a geometric point of view.

Our problem is that of establishing conditions under which  $x_w \rightarrow x_{w_0}$  and  $u_w \rightarrow u_{w_0}$  in the  $L^2$  sense as  $\omega \rightarrow \omega_0$ . If  $(x_w, u_w)$  converges then for each  $\epsilon > 0$  there exists a neighborhood  $V$  of  $\omega_0$  such that if  $\omega \in V$  then

$$\|u_w - u_{w_0}\| < \epsilon \quad (7.10)$$

$$\|\eta_w + \mathcal{J}_w(u_{w_0}) - x_w\| < \epsilon \quad (7.11)$$

and

$$|J(\eta_w + \mathcal{J}_w(u_{w_0}), u_{w_0}) - J(x_w, u_w)| < \epsilon \quad (7.12)$$

since  $\mathcal{J}_w$  and  $J$  are continuous. Thus, for small perturbations about  $\omega_0$ , the solution  $u_{w_0}$  of the regulator problem at  $\omega_0$  can be applied to the

AD-A123 970

DESCRIPTOR VARIABLE AND GENERALIZED SINGULARLY  
PERTURBED SYSTEMS: A GEOMETRIC APPROACH(U) ILLINOIS  
UNIV AT URBANA DECISION AND CONTROL LAB J D COBB

2/2

UNCLASSIFIED

MAY 80 DC-38 NO0014-79-C-0424

F/G 12/1

NL

END
DATE
FILED
83
DEC

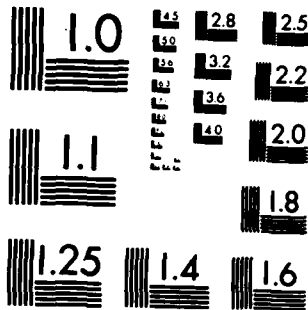

MICROCOPY RESOLUTION TEST CHART  
NATIONAL BUREAU OF STANDARDS-1963-A

perturbed system with only a slight deviation from the optimal trajectory and optimal cost. It will be shown that solving the problem at  $\omega_0$  explicitly for  $u_{\omega_0}$  is simpler computationally than solving the problem at  $\omega \neq \omega_0$  for  $u_{\omega}$ . Hence, a computational savings can be achieved at the cost of slight suboptimality.

### 7.3. Reduced-Order Solution at $\omega_0$

As a result of the reduction in order that occurs in the system at  $\omega_0$ , solving the regulator problem explicitly at  $\omega_0$  turns out to be simpler than solving it for some other  $\omega$ . To see this, choose an orthonormal basis  $(e_1, \dots, e_r)$  of  $S(\omega_0)$ , an arbitrary basis  $(e_{r+1}, \dots, e_n)$  of  $F(\omega_0)$  and an orthogonal basis  $(v_1, \dots, v_m)$  of  $U$  with  $\|v_i\| = \gamma$ ,  $i = 1, \dots, m$  for some  $\gamma > 0$ . If  $u \in L^2(U)$  and  $x \in L^2(X)$  with  $x = x_s + x_f$ ,  $x_s(t) \in S(\omega_0)$ ,  $x_f(t) \in F(\omega_0)$ , and

$$x_s(t) = \alpha_1(t)e_1 + \dots + \alpha_r(t)e_r \quad (7.13)$$

$$x_f(t) = \beta_1(t)e_{r+1} + \dots + \beta_{n-r}(t)e_n \quad (7.14)$$

$$u(t) = \psi_1(t)v_1 + \dots + \psi_m(t)v_m \quad (7.15)$$

then

$$J(x, u) = \int_0^{\infty} \alpha(t)^* \alpha(t) + 2\alpha(t)^* N\beta(t) + \beta(t)^* Q\beta(t) + \gamma^2 \psi(t)^* \psi(t) dt \quad (7.16)$$

where  $\alpha(t)$ ,  $\beta(t)$ , and  $\psi(t)$  are column vectors consisting of the  $\alpha_i(t)$ ,  $\beta_i(t)$ , and  $\psi_i(t)$  and

1  
1  
1

$$N = \begin{bmatrix} \langle e_1, e_{r+1} \rangle & \dots & \langle e_1, e_n \rangle \\ \vdots & & \vdots \\ \langle e_r, e_{r+1} \rangle & \dots & \langle e_r, e_n \rangle \end{bmatrix} \quad (7.17)$$

$$Q = \begin{bmatrix} \langle e_{r+1}, e_{r+1} \rangle & \dots & \langle e_{r+1}, e_n \rangle \\ \vdots & & \vdots \\ \langle e_n, e_{r+1} \rangle & \dots & \langle e_n, e_n \rangle \end{bmatrix}. \quad (7.18)$$

If  $(x, u) \in (\eta_\omega, 0) + \Lambda(\omega_0)$  then  $x(t) = x_s(t) + x_f(t) = x_s(t) - B_f(\omega_0)u$

so we may equivalently minimize

$$\begin{aligned} \hat{J}(x_s, u) = J(x_s - B_f(\omega_0)u, u) = & \int_0^\infty \alpha(t)^* \alpha(t) - 2\alpha(t)^* NK\psi(t) \\ & + \psi(t)^* (\gamma^2 I + K^* QK) \psi(t) dt \end{aligned} \quad (7.19)$$

where  $K = \text{Mat } B_f(\omega_0)$ .

In [31], pp. 46-48 it is shown that the optimization problem with cost (7.19) and system

$$\dot{\alpha}(t) = G\alpha(t) + H\psi(t) \quad (7.20)$$

may be reduced to that of minimizing

$$\bar{J}(\alpha, \phi) = \int_0^\infty \alpha(t)^* (I - NK(\gamma^2 I + K^* QK)^{-1} K^* N^*) \alpha(t) + \phi(t)^* (\gamma^2 I + K^* QK) \phi(t) dt \quad (7.21)$$

subject to

$$\dot{\alpha}(t) = (G - H(\gamma^2 I + K^* QK)^{-1} K^* N^*) \alpha(t) + H\phi(t) \quad (7.22)$$

if  $I - NK(\gamma^2 I + K^* QK)^{-1} K^* N^*$  is positive semidefinite.

**Lemma 7.1.** There exists  $\gamma > 0$  such that  $I - NK(\gamma^2 I + K^* QK)^{-1} K^* N^*$  is positive definite.

**Proof:** The matrix  $T = NK(\gamma^2 I + K^* QK)^{-1} K^* N^*$  is clearly Hermitian, positive semidefinite since  $Q$  is positive definite. We need to show only that for

some  $\gamma > 0$  the eigenvalues of  $T$  are less than unity. Since the eigenvalues of a matrix are bounded above by its norm, it is sufficient to show that

$$\|(Y^2 I + K^* Q K)^{-1}\| < \frac{1}{\|NK\|^2}$$

for some  $\gamma$ .

According to a well-known result, there exists  $p > 0$  such that

$$\|L\| < p \xi(L)$$

for all  $L \in C^{m \times m}$  where  $\xi$  is the spectral norm. Let  $\mu$  be the minimum eigenvalue of  $K^* Q K$  and let

$$\gamma > \sqrt{\max\{p\|NK\|^2 - \mu, 0\}}.$$

Then

$$\|(Y^2 I + K^* Q K)^{-1}\| < p \xi((Y^2 I + K^* Q K)^{-1}) = \frac{p}{\gamma^2 + \mu} < \frac{1}{\|NK\|^2}.$$

This completes the proof.

Setting  $G = \text{Mat } L_s(\omega_0)$  and  $H = \text{Mat } B_s(\omega_0)$  and choosing  $\gamma$  as in lemma 7.1 we may solve the regulator problem at  $\omega_0$  by minimizing  $\bar{J}$  subject to (7.22) which necessitates the solution of an  $r$ th order Riccati equation. Compared to the  $n$ th order problem for  $\omega \neq \omega_0$ , the  $r$ th order problem is a considerable computational simplification. The remainder of this chapter is devoted to finding conditions under which the solution of the reduced order problem is close to that of the full order perturbed problem.

#### 7.4. Convergence of $\Lambda(\omega)$

In order to establish convergence of the optimal solution  $(x_\omega, u_\omega)$  it is convenient to establish convergence of  $\Lambda(\omega)$  with respect to a certain

metric on the closed subspaces of  $L^2(X) \times L^2(U)$ . Let  $\mathcal{M}$  be the set of closed subspaces of a Hilbert space  $H$ . In [32] and [33] a metric  $\rho$  on  $\mathcal{M}$  is discussed giving two equivalent expressions. Let

$$\rho(R, T) = \|P_R - P_T\| = \max \left\{ \sup_{\substack{x \in R \\ \|x\| \leq 1}} D[x, T], \sup_{\substack{x \in T \\ \|x\| \leq 1}} D[x, R] \right\} \quad (7.23)$$

for any  $R, T \in \mathcal{M}$  where

$$D[x, T] = \inf_{y \in T} \|x - y\|. \quad (7.24)$$

Note that  $(\mathcal{M}, \rho)$  is a generalization of the metric space considered in Chapter 4.

Theorem 7.1. If  $\int_0^\infty \|e^{tL_f(\omega)}\|^{-1} dt \rightarrow 0$  as  $\omega \rightarrow \omega_0$  then the mapping  $\omega \rightarrow \Lambda(\omega)$  is continuous at  $\omega_0$  with respect to  $\rho$ .

Proof: Observe that

$$\begin{aligned} \sup_{\substack{(x,u) \in \Lambda(\omega) \\ \|(x,u)\| \leq 1}} D[(x,u), \Lambda(\omega_0)]^2 &\leq \sup_{\substack{u \in L^2(U) \\ \|u\| \leq 1}} D[(\mathcal{J}_\omega(u), u), \Lambda(\omega_0)]^2 \\ &= \sup_{\substack{u \in L^2(U) \\ \|u\| \leq 1}} \inf_{v \in L^2(U)} \|(\mathcal{J}_\omega(u) - \mathcal{J}_{\omega_0}(u), u-v)\|^2 \leq \sup_{\substack{u \in L^2(U) \\ \|u\| \leq 1}} \|\mathcal{J}_\omega(u) - \mathcal{J}_{\omega_0}(u)\|^2 \\ &= \|\mathcal{J}_\omega - \mathcal{J}_{\omega_0}\|^2. \end{aligned}$$

Similarly,

$$\sup_{\substack{(x,u) \in \Lambda(\omega_0) \\ \|(x,u)\| \leq 1}} D[(x,u), \Lambda(\omega)] \leq \|\mathcal{J}_\omega - \mathcal{J}_{\omega_0}\|$$

so from (7.4), convergence of  $\int_0^\infty \|e^{tL_f(\omega)}\|^{-1} dt$  to 0 and stability of  $L_s(\omega_0)$  guarantee that



$$\rho(\Lambda(\omega), \Lambda(\omega_0)) \rightarrow 0$$

as  $\omega \rightarrow \omega_0$  and the proof is complete.

### 7.5. Convergence of the Optimal Solution

We now give sufficient conditions under which  $\omega \rightarrow (x_\omega, u_\omega)$  is continuous at  $\omega_0$ .

**Theorem 7.2.** If  $\int_0^\infty \|e^{tL_f(\omega)}\|^{-1} dt \rightarrow 0$  and  $\int_0^\infty \|e^{tL_f(\omega)}\|^{-2} dt \rightarrow 0$  as  $\omega \rightarrow \omega_0$  then  $\omega \rightarrow (x_\omega, u_\omega)$  is continuous at  $\omega_0$ .

**Proof:** First observe that

$$\|\tilde{\eta}_\omega - \tilde{\eta}_{\omega_0}\| \leq \sqrt{\int_0^\infty \|e^{tL_f(\omega)}\|^{-2} \|x_{f_0}(\omega)\|^2 dt} + \|e^{(L_s(\omega))x_{s_0}(\omega)} - e^{(L_s(\omega_0))x_{s_0}(\omega_0)}\|$$

so stability of  $L_s(\omega_0)$  and the second hypothesis of the theorem imply

$\tilde{\eta}_\omega \rightarrow \tilde{\eta}_{\omega_0}$ . But the first hypothesis guarantees that

$$P_{\Lambda(\omega)} \rightarrow P_{\Lambda(\omega_0)}$$

from (7.23). From (7.9) we have

$$\|(x_\omega, u_\omega) - (x_{\omega_0}, u_{\omega_0})\| \leq \|\tilde{\eta}_\omega - \tilde{\eta}_{\omega_0}\| + \|P_{\Lambda(\omega)} - P_{\Lambda(\omega_0)}\| \|\tilde{\eta}_{\omega_0}\|$$

and the desired result follows.

Since the hypothesis of theorem 7.2 implies that

$$\int_0^\infty \|e^{tL_f(\omega)}\|^{-1} dt < \infty \quad (7.25)$$

throughout a neighborhood of  $\omega_0$  and since

$$\int_0^\infty \|e^{tL_f(\omega)}\|^{-2} dt \geq \int_0^\infty e^{2t \operatorname{Re} \frac{1}{\sigma_j(\omega)}} dt = \begin{cases} \infty & \text{if } \operatorname{Re} \frac{1}{\sigma_j(\omega)} \geq 0 \\ \frac{1}{2 \operatorname{Re} \frac{1}{\sigma_j(\omega)}} & \text{if } \operatorname{Re} \frac{1}{\sigma_j(\omega)} < 0 \end{cases} \quad (7.26)$$

for all  $\omega \in \Omega$ ,  $j=1, \dots, n-r$ , it follows that it is necessary for  $L_f(\omega)$  to be stable throughout a neighborhood of  $\omega_0$  in order that the sufficiency condition of theorem 7.2 hold.

The sufficient condition of theorem 7.2 guarantees that the reduced order problem at  $\omega_0$  may be solved yielding only a slightly sub-optimal control which is close to the optimal control and which generates a trajectory close to the optimal trajectory in the  $L^2$  sense. Under most circumstances it is reasonable to interpret the convergence criteria of theorems 7.1 and 7.2 as conditions on the behavior of the boundary layer in singularly perturbed systems, for if the natural response converges uniformly to zero in  $[\epsilon, \infty)$  the integrals are essentially measures of the intensity of the boundary layer effect in  $[0, \epsilon)$ . The integral convergence conditions state that the effect of the boundary layer becomes vanishingly small as  $\omega \rightarrow \omega_0$ .

## CHAPTER 8

## ALTERNATIVE FORMULATIONS AND CONCLUSIONS

8.1. Algebraic Interpretations

Although it was not explicitly stated in previous chapters, there are abstract algebraic interpretations for many of the results encountered so far in our study of singularly perturbed systems. These interpretations have not been explored in much detail yet, but they are presented here for completeness and as a suggestion for further study.

To begin with, consider the set of all mappings  $\lambda : \Omega \rightarrow \mathbb{C}$ , continuous at  $\omega_0$ . Such mappings have been considered extensively, starting with Chapter 4, but we have not considered properties of the set of all such maps. Denote the set by  $C(\omega_0)$ . With little effort it can be shown that  $C(\omega_0)$  is a commutative ring with identity using pointwise addition and multiplication. Letting  $\mathcal{I}(\omega_0)$  denote the subset of  $C(\omega_0)$  consisting of all  $\lambda$  with  $\lambda(\omega_0) = 0$ , it can be shown that  $\mathcal{I}(\omega_0)$  is an ideal of  $C(\omega_0)$ . Lemma 4.3 may be interpreted as a factorization theorem for polynomials over  $C(\omega_0)$ .

Let  $\mathcal{Q}_X$  be the set of maps  $x : \Omega \rightarrow X$ , continuous at  $\omega_0$ . Using pointwise addition and scalar multiplication,  $\mathcal{Q}_X$  is a  $C(\omega_0)$ -module. Let  $\mathcal{M}$  be the set of subspaces of  $X$  and  $R : \Omega \rightarrow \mathcal{M}$  be continuous at  $\omega_0$  with dimension  $p$  for all  $\omega \in \Omega$ . For example,  $R$  may be the slow or fast subspace map  $S$  or  $F$  as defined in Chapter 4.  $R$  may be identified with a submodule of  $\mathcal{Q}_X$  in the following natural way. As outlined in lemma 4.2 choose a basis  $(x_1(\omega), \dots, x_p(\omega))$  of  $R(\omega)$  with  $x_i$  continuous at  $\omega_0$ . Then  $x_i \in \mathcal{Q}_X$  and  $\{x_1, \dots, x_p\}$  is linearly independent since

$$\alpha_1(\omega)x_1(\omega) + \dots + \alpha_p(\omega)x_p(\omega) = 0 \quad (8.1)$$

implies  $\alpha_i(\omega) = 0$  for all  $\omega$ ,  $i=1, \dots, p$ . Let  $(y_1(\omega), \dots, y_p(\omega))$  be another basis of  $R(\omega)$ , continuous at  $\omega_0$ . Then

$$y_i(\omega) = \beta_1(\omega)x_1(\omega) + \dots + \beta_p(\omega)x_p(\omega) \quad (8.2)$$

with  $\beta_i \in C(\omega_0)$  by lemma 4.1. Hence,

$$\text{span}\{y_1, \dots, y_p\} \subset \text{span}\{x_1, \dots, x_p\}. \quad (8.3)$$

By reversing the argument,

$$\text{span}\{x_1, \dots, x_p\} \subset \text{span}\{y_1, \dots, y_p\} \quad (8.4)$$

so we may naturally and without ambiguity identify  $R$  with  $\text{span}\{x_1, \dots, x_p\}$ .

In our study of singularly perturbed systems we considered operator valued maps  $A \in H_R(X)$ . Members of  $H_R(X)$  can be identified with linear transformations on the submodule  $R$  by setting

$$(Ax)(\omega) = A(\omega)x(\omega). \quad (8.5)$$

$H_R(X)$  admits the structure of a  $C(\omega_0)$ -algebra. Let

$$(A+B)(\omega) = A(\omega) + B(\omega) \quad (8.6)$$

$$(AB)(\omega) = A(\omega)B(\omega) \quad (8.7)$$

$$(\lambda A)(\omega) = \lambda(\omega)A(\omega) \quad (8.8)$$

for  $A, B \in H_R(X)$ .

Following the same line of reasoning it can be seen that the set  $Q_U$  of all maps  $u: \Omega \rightarrow U$  that are continuous at  $\omega_0$  is a  $C(\omega_0)$ -module. Also,  $H_R(U)$  is a  $C(\omega_0)$ -module of linear transformations from  $Q_U$  into  $Q_X$ .

Consider pencils (i.e. first degree polynomials) over the algebra

$H_R(X)$ . Using lemmas 4.1 and 4.2 it is easily shown that all the bases of the submodule  $R$  have the same number of elements. For  $G, L \in H_R(X)$  each basis of  $R$  determines  $r \times r$  matrix representations of  $G$  and  $L$  with entries in  $C(\omega_0)$ . It also determines a matrix representation of the pencil  $(G, L)$ <sup>1</sup> with entries in the  $C(\omega_0)$ -algebra  $C(\omega_0)[s]$  of polynomials over  $C(\omega_0)$  in the indeterminate  $s$ . The determinant of the pencil  $(E, A)$  may be defined by forming the determinant of  $\text{Mat}(E, A)$  in the usual way with respect to some basis yielding

$$\det(E, A) \in C(\omega_0)[s]. \quad (8.9)$$

A simple argument shows that  $\det(E, A)$  is independent of the basis chosen.

Consider  $A \in H_R(X)$  and let

$$\det(I, A) = \Psi \prod_{i=1}^p (s - \eta_i) \quad (8.10)$$

where  $I$  is the identity element of  $H_R(X)$  and  $\Psi \in C(\omega_0)$  is invertible.

( $\Psi$  is invertible if and only if  $\Psi(\omega) \neq 0$  for all  $\omega \in \Omega$ ). Define

$$\sigma(A) = \{\eta_i \mid i=1, \dots, p\} \quad (8.11)$$

The  $\eta_i$  can be considered as eigenvalues of  $A$ .

We are now in a position to interpret the central singular perturbation decomposition result, theorem 4.1, algebraically. Suppose that  $E, A \in H_X(X)$  with

$$\det(E, A) = \phi_0 \left( \prod_{i=1}^r (s - \lambda_i) \right) \left( \prod_{i=1}^{n-r} (\sigma_i s - 1) \right) \quad (8.12)$$

where  $\phi_0 \in C(\omega_0)$  is invertible and  $\sigma_i \in \mathcal{Z}(\omega_0)$ . This can be done according to

<sup>1</sup>The pencil  $(G, H)$  is often written  $Gs - H$ .

lemma 4.3. Theorem 4.1 states that

$$(E,A) = N * (K,L) \quad (8.13)$$

where  $N$  is an invertible constant polynomial over  $H_X(X)$ , "\*" denotes polynomial multiplication, and  $K$  and  $L$  are both  $S$ - and  $F$ -invariant with

$$K | S = I \in H_S(X) \quad (8.14)$$

$$L | F = I \in H_F(X) \quad (8.15)$$

$$\sigma(K|F) = \{\sigma_i | i=1, \dots, n-r\} \quad (8.16)$$

$$\sigma(L|S) = \{\lambda_i | i=1, \dots, r\}. \quad (8.17)$$

Theorem 4.1 may be interpreted as a canonical factorization result for regular pencils (i.e. with  $\det(E,A) \neq 0$ ) over  $H_X(X)$ .

## 8.2. Geometry of the Space of Linear Systems

Let  $\Gamma$  be the complex Euclidean space of ordered pairs of  $n \times n$  matrices  $(E,A)$ . There is an obvious one-to-one correspondence between  $\Gamma$  and differential equations  $E\dot{x} = Ax$ . Hence each point of  $\Gamma$  can be interpreted as a linear system of one of the following three types: 1) a state variable system if  $E$  is nonsingular, 2) a descriptor variable system if  $E$  is singular and  $\det(Es-A) \neq 0$ , 3) a degenerate system if  $\det(Es-A) \equiv 0$ .<sup>2</sup> Viewing linear systems in this way is natural since a small perturbation of a given system in the Euclidean norm is equivalent to a small perturbation in the system parameters.

Studying the geometry of  $\Gamma$  adds valuable insight into the nature of descriptor variable and singularly perturbed systems. With little effort

<sup>2</sup>This implies, of course, that  $E$  is singular.

it can be shown that descriptor and degenerate systems together form a hypersurface in  $\Gamma$  contained in the boundary of the set of state variable systems. The property of being state variable is a generic property of  $\Gamma$ .

It is an unfortunate fact that for every descriptor system in  $\Gamma$  there exists a sequence of state variable systems converging to it with the corresponding sequences of eigenvalues diverging to  $+\infty$ . That is, if a descriptor system is perturbed in the wrong direction, the perturbed system will have tremendous instability, the smaller the perturbation, the greater the instability. It is as if every descriptor system is perched precariously on the edge of a cliff. A step in one direction will result in only a slight change in its characteristics. A step in the other direction will have disastrous consequence. The importance of establishing simple conditions that guarantee trajectory convergence is clear. If a designer fails to account for the possibility that a descriptor system's parameters are slightly different from what he thinks they are, his whole design could fail miserably.

Let  $D \subset \Gamma$  be the set of degenerate systems. One way to view the question of trajectory convergence is to consider the map  $\xi_x : \Gamma - D \rightarrow \mathcal{D}_0(X)$  which associates with each pair  $(E, A)$  the solution of  $E\dot{z} = Az$  for initial condition  $x \in X$ . If a topology is placed on  $\mathcal{D}_0(X)$  (e.g. see Chapter 5) then we need to ask questions about the weakest topology on  $\Gamma$  that makes  $\xi_x$  continuous. Once the nature of the resulting neighborhoods of a descriptor system is understood, the behavior of the solutions of a singularly perturbed system (which is nothing more than a map from  $\Omega$  into  $\Gamma$ , continuous at  $\omega_0$ , or the parameterization of a particular path in  $\Gamma$ ) can be determined by checking to see if an arbitrarily small neighborhood of the descriptor system

contains the image of some neighborhood of  $\omega_0$ .

So far in this section we have considered only pairs of matrices corresponding to unforced systems with fixed initial conditions. In order to study the behavior of a forced system with a parametrically varying initial condition,  $\Gamma$  must be the space of 4-tuples  $(E, A, B, x)$  where  $B$  is  $n \times m$  and  $x$  is  $n \times 1$ . Our previous discussion of geometry and induced topology carries through with only minor changes.

### 8.3. Suggestions for Further Research

In the area of descriptor variable theory there are many avenues which have yet to be explored. For example, although observability of descriptor systems has been considered in [7], the descriptor variable equivalent of observers from state variable theory have not been developed. In a stochastic environment the Kalman filter might also have a natural extension to descriptor systems. There are many fundamental control-theoretic concepts such as the Maximum Principle and various stochastic and adaptive control techniques that have yet to be considered in the context of descriptor variable theory.

Clearly, the problem of trajectory convergence in singularly perturbed systems has, for the most part, not been solved except for certain standard systems. The general case that we have considered still requires a great deal more work. The resolution of this issue is essential. As we have seen in the last section, the survival of the descriptor variable approach to system modeling depends on it.

As with descriptor systems, many system-theoretic concepts have not as yet been extended to singularly perturbed systems. In Chapter 7 we studied the regulator problem for  $L_s(\omega_0)$  stable and  $L_f(\omega_0) = 0$ . The same



problem needs to be considered with the two assumptions dropped. It is safe to say that if a problem has not been studied in the context of descriptor systems then it needs to be studied in the context of generalized singularly perturbed systems. If a given system is close to a descriptor system in the Euclidean norm then conditions are needed to insure that one need only consider the nearby descriptor system. If a designer is guaranteed that the application of some design technique to the descriptor system will yield results close to those that would come from working with the given system, then he may choose to apply that technique to the reduced order descriptor system. Such an action often results in increased computational efficiency. Of course, the price is always inferior system performance.

#### 8.4. Conclusions

In this thesis three central points have become clear. First, there are many alternative ways to view descriptor variable and singularly perturbed systems. They range from the matrix oriented approaches which exist in most of the literature to the geometric theory developed in Chapters 2 through 7 to the algebraic ideas discussed briefly in this chapter. Certainly, there are other interpretations as well that no one has even thought of yet. The more ways that exist to look at a problem, the more likely it is that the problem will be solved in the near future.

The second point is that descriptor systems must be considered as members of the space  $\Gamma$ . Since they are located in such precarious positions in  $\Gamma$ , failure to consider their spatial relationships with nearly state variable systems could result in unexpected system behavior, to put

it mildly. The question of trajectory convergence has yet to be answered satisfactorily.

Finally, there are still many important control-theoretic concepts that have not been extended to singularly perturbed systems. We have made some progress in the pole placement and regulator problems in Chapters 3 and 7, but many other problems still exist.

## REFERENCES

- [1] K. Weierstrass, Zur Theorie der Bilinearen und Quadratischen Formen, Monatsh. Akad. Wiss. Berlin, 310-338, 1867.
- [2] F. R. Gantmacher, The Theory of Matricies, Chelsea, New York, 1964.
- [3] H. H. Rosenbrock, State-Space and Multivariable Theory, John Wiley & Sons, Inc., 1970.
- [4] H. H. Rosenbrock, "Structural Properties of Linear Dynamical Systems," Int. J. Control, Vol. 20, 191-202, 1974.
- [5] G. Verghese, B. Levy, T. Kailath, "Generalized State-Space Systems," Stanford University, Information Systems Lab., Unpublished Report, 1977.
- [6] P. Van Dooren, G. Verghese, T. Kailath, "Properties of the System Matrix of a Generalized State-Space System," Proc. IEEE Conf. on Decision and Control, 1978.
- [7] G. Verghese, "Infinite-Frequency Behavior in Generalized Dynamical Systems;" Stanford University, Information Systems Laboratory, Unpublished Report, 1978.
- [8] D. G. Luenberger, "Dynamic Equations in Descriptor Form," IEEE Trans. on Automatic Control, AC-22, 312-321, 1977.
- [9] D. G. Luenberger, A. Arbel, "Singular Dynamic Leontief Systems," Econometrica, 991-995, 1977.
- [10] R. E. Larson, D. G. Luenberger, D. N. Stengel, Descriptor Variable Theory and Spatial Dynamic Programming, Topical Report, Systems Control, Inc., 1978.
- [11] S. L. Campbell, C. D. Meyer, N. J. Rose, "Applications of the Drazin Inverse to Linear Systems of Differential Equations with Singular Constant Coefficients," SIAM J. Appl. Math., Vol. 31, No. 3, 411-425, 1976.
- [12] P. V. Kokotovic, R. E. O'Malley, P. Sannuti, "Singular Perturbations and Order Reduction in Control Theory - An Overview," Automatica, Vol. 12, 123-132, 1976.
- [13] V. F. Butuzov, A. B. Vasileva, M. V. Fedoryuk, "Asymptotic Methods in the Theory of Ordinary Differential Equations," Progress in Mathematics, Vol. 8, 1-82, Plenum Press, New York, 1970.

- [14] R. E. O'Malley, Introduction to Singular Perturbations, Academic Press, New York, 1974.
- [15] J. H. Chow, P. V. Kokotovic, "A Decomposition of Near-Optimum Regulators for Systems with Slow and Fast Modes," IEEE Trans. on Automatic Control, 701-705, Oct., 1976.
- [16] B. Porter, "Singular Perturbation Methods in the Synthesis of Feedback Control Laws for Eigenvalue Assignment in Multivariable Linear Systems," Int. J. Systems Sci., Vol. 7, No. 5, 597-601, 1976.
- [17] P. V. Kokotovic and A. H. Haddad, "Controllability and Time-Optimal Control of Systems with Slow and Fast Modes," IEEE Trans. on Automatic Control, AC-20, 111-113, 1975.
- [18] H. K. Khalil, "Multimodeling and Multiparameter Singular Perturbation in Control and Game Theory," University of Illinois, Coordinated Science Lab. Report T-65, 1978.
- [19] F. Hoppensteadt, "Properties of Solution of Ordinary Differential Equations with Small Parameters," Comm. Pure and Appl. Math., XXIV, 807-840, 1971.
- [20] S. L. Campbell, "On a Singularly Perturbed Autonomous Linear Control Problem," IEEE Trans. on Automatic Control, AC-24, No. 1, 115-117, 1979.
- [21] W. M. Wonham, Linear Multivariable Control: a Geometric Approach, Springer Verlag, 1974.
- [22] W. Rudin, Real and Complex Analysis, McGraw Hill, 1966.
- [23] R. B. Ash, Real Analysis and Probability, Academic Press, 1972.
- [24] I. M. Gelfand, G. E. Shilov, Generalized Functions, Academic Press, 1964.
- [25] S. Warner, Classical Modern Algebra, Prentice Hall, Inc., 1971.
- [26] M. Marden, Geometry of Polynomials, American Mathematical Society, 1966.
- [27] D. G. Luenberger, Optimization by Vector Space Methods, John Wiley & Sons, Inc., 1969.
- [28] S. L. Campbell, N. J. Rose, "Singular Perturbation of Autonomous Linear Systems," SIAM J. Math. Anal., Vol. 10, No. 3, May 1979.

- [29] J. B. Conway, Functions of One Complex Variable, Springer-Verlag, 1978.
- [30] T. Kato, Perturbation Theory for Linear Operators, Springer-Verlag, 1966.
- [31] B. D. O. Anderson, J. B. Moore, Linear Optimal Control, Prentice-Hall, 1971.
- [32] E. Berkson, "Some Metrics on the Subspaces of a Banach Space," Pacific J. Math., Vol. 13, No. 1, 7-22, 1963.
- [33] N. I. Akhiezer, I. M. Glazman, Theory of Linear Operators in Hilbert Space, Fredrick Ungar Publishing Co., 1961.
- [34] S. L. Campbell, "Singular Perturbation of Autonomous Linear Systems, II," J. Diff. Equations, 362-373, September 1978.
- [35] S. L. Campbell, "Singular Perturbation of Autonomous Linear Systems, III," Houston J. Math., 527-539, Vol. 4, No. 4, 1978.
- [36] S. L. Campbell, "Singular Perturbation of Autonomous Linear Systems, IV," Singular Systems of Differential Equations, Dec. 1979.

VITA

J. Daniel Cobb was born in Chicago, Illinois on May 10, 1953. He received the B.S. degree in electrical engineering from the Illinois Institute of Technology, Chicago, Illinois in 1975 and the M.S. degree in electrical engineering from the University of Illinois at Urbana-Champaign in 1977.

From August, 1975 until December, 1976 he was a teaching assistant in the Department of Electrical Engineering at the University of Illinois. He was a research assistant at the Coordinated Science Laboratory in Urbana, Illinois from January 1977 until finishing his Ph.D. research.

**MED**  
**8**