



IJRASET

International Journal For Research in
Applied Science and Engineering Technology



INTERNATIONAL JOURNAL FOR RESEARCH

IN APPLIED SCIENCE & ENGINEERING TECHNOLOGY

Volume: 11 Issue: III Month of publication: March 2023

DOI: <https://doi.org/10.22214/ijraset.2023.49727>

www.ijraset.com

Call:  08813907089

E-mail ID: ijraset@gmail.com

Design and Analysis of Quad Copter Chassis Using Shape Optimization Technique

Srawanee Sreeramoju¹, M. Sreenivasa Rao²

¹Research scholar & Assistant Professor, Department of Mechanical Engineering, JNTUH, Telangana, India

² Professor, Department of Mechanical Engineering, JNTUH, Telangana, India.

Abstract: Unmanned aerial vehicles (UAVs) are replacing many traditional methods ranging from simple play toys to critical defense operations. UAVs or drones that are the little flying machines are used in space, defense, food delivery, pest sprays for agriculture, consumer goods delivery, land-surveillance and the list goes on. However, the physics behind it demands a lesser weight for drone to fly high as lesser the weight, lesser is the power required to operate. In all the components that make up a drone, is the frame that is most important structure which holds and bears everything at place. So the material used for the drone frame plays a very crucial role for it should have a lesser mass but sufficient strength. In this work, frame is modeled taking into consideration, its sturdiness and stress analysis is conducted using Autodesk Fusion 360 software and compared for different materials of frames from plastics to metals and the design is shape optimized to meet the objective.

Keywords: Unmanned aerial vehicles; drone frames; design optimization; stress analysis; FEM analysis; Shape optimization;

I. INTRODUCTION

A drone is a flying machine which is a pilotless aircraft formally known as UAV. Since it does not need a human pilot and taking the advantage of sizing the UAV as per the requirement, the application areas are far very wide for a UAV. They are used in agriculture, monitoring, transportation, goods delivery agent, land-surveillance, inspection [1] only to name a few. To be able to fly, drones must be able to generate upward thrust to overcome their own weight. This makes drone a weight critical object where any additional gram on the flying machine will turn out to be costly. Another important aspect that cannot be overlooked is the need to cut down material utilization to as much as possible. Material depletion rates are alarming and so are the pollution rates, which demands to lessen material wastage and landfill. On the design side of a drone, higher the material, higher is the weight. Higher the weight, higher will be the power consumption. So a design that can cut down material without affecting the strength and mechanical properties is a great opportunity to overcome all the limitations that come from a larger mass [2]. Every gram that is lessened can improve the performance of drone like increased payload carrying capacity, extended flight times, better maneuverability, less material consumption, low power consumption, less wastage that means less pollution and landfill, and more economical.

A. Quad copter frame

Frame is the structure of drone. It holds and bears everything at place acting as a skeleton to fit in all the components of drone. The size of the frame is measured as the diagonal distance between motors. If this dimension is less than 150mm, the size is categorized under micro, otherwise it is considered as a mini. Depending on the no. of motors, drones are named as tri-copter, quad-copter, hex-copter, etc. of which quad-copter is the most popular design for the following reasons: mechanical simplicity, quantity of motors and Electronic Speed Controllers (ESCs) required for flight and their compact size.

II. PROBLEM STATEMENT

In this work, frame is chosen as weight critical component. Unibody design will be stiffer and stronger, hence as unibody quad-copter is considered in this work for which shape optimization of frame is carried out to attain a low mass structure without affecting the strength [3].

Since weight is directly proportional to cost, that includes the flight times, range, material depletion, material wastage, pollution are a few that makes up to total cost of a heavy weight object, shape optimization tool is utilized to reduce the weight of the component. Shape optimization technique is applied to drone frame to reduce the mass of the frame without affecting the strength, sturdiness and stiffness of the frame.

III.OBJECTIVE

- 1) To design simple multi-functional frame for higher payload capacities (about 2.14 kg)
- 2) To make a simple but aesthetically appealing design
- 3) To make a low weight component
- 4) To make a good strength frame
- 5) Should be economical

IV.GENERAL DESIGN AND ANALYSIS OF QUAD COPTER FRAME

A. Basic Design of Quad Copter Frame

The quad copter frame is designed to hold all the components in place. Design is carried out as per the figures 1 and 2 shown below. Frame size is 210 mm for a 4 to 5 inch propeller which is the diagonal distance from motor to motor. Each motor is positioned at right angle to adjacent motor to ensure stability and equal weight and thrust distribution [4, 5]. Three most popular materials used for drone frame are selected viz., Aluminium [6, 7], Al A356 T6 [8] and ABS plastic [9,10] keeping in mind their mechanical properties like strength, rigidity (as shown in table 1), weight, cost and availability.

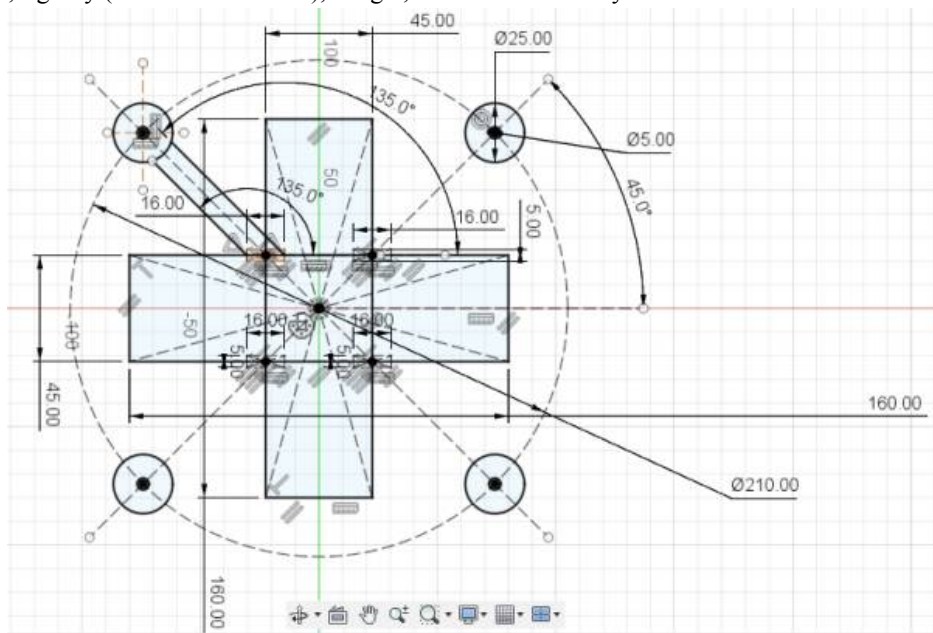

Fig. 1 Design specifications of quadcopter frame structure

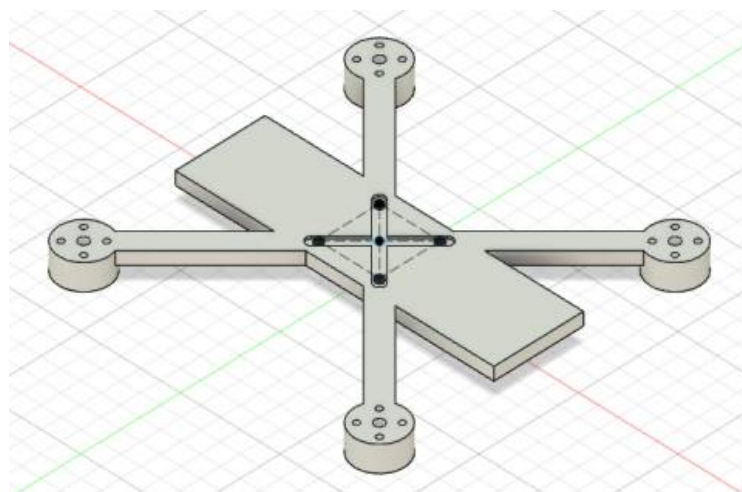

Fig. 2 Quadcopter frame (basic model)

Table 1 Comparison of properties between Al, Al A356 T6 and ABS plastic for basic model

Property	Aluminium	Al A356 T6	ABS Plastic
Density kg / mm ³	2.7E-06	2.67E-06	1.06E-06
Mass g	216.661	214.254	85.06
Volume mm ³	80244.84	80244.84	80244.84
Young's Modulus E (MPa)	68900	72400	2240
Poisson's Ratio	0.33	0.33	0.38
Moment of Inertia (g mm ²)			
Ixx	4.342E+05	4.294E+05	1.705E+05
Iyy	6.629E+05	6.555E+05	2.602E+05
Izz	1.094E+06	1.082E+06	4.295E+05
Yield Strength MPa	275	165	20
Ultimate Tensile Strength MPa	310	234	29.6

Table 2 shows the components of drone that frame carries along with quantity and weight [11-14]. In current work, frame design is made to withstand a load of 2.14 kg (ie. 21N)

Table 2 Components of drone that frame carries along with quantity and weight

S. No.	Name of the Component	Quantity	Weight (in grams)
1	Motors	4	138
2	Electronic Speed Controller (ESC)	4	412
3	Flight control board	1	82
4	5" Propellers	4	10
5	Battery	4	600
6	GPS, electronics, power distribution cables		100
Total approximate weight			1342

B. Analysis of Basic Design of Quad Copter Frame

Quad copter frame is analyzed for static stress [15, 16] using Fusion 360 software for which the following materials are considered: Aluminium, A356 T6 and ABS plastic.

- 1) *Boundary Conditions:* The motor mount holes (4X4=16) are fixed (Fig 3)
- 2) *Loading Conditions:* Weight of 21N is applied on the frame, along with thrust of 10N for each motor acting upwards. (Fig 4)
- 3) *Mesh Settings:* Fine mesh of tetrahedron shape of absolute size of 1mm is created with 760746 nodes and 518391 elements.

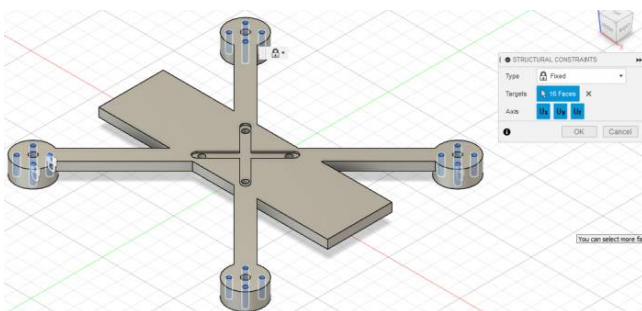

Fig 3 Motor mount holes are fixed

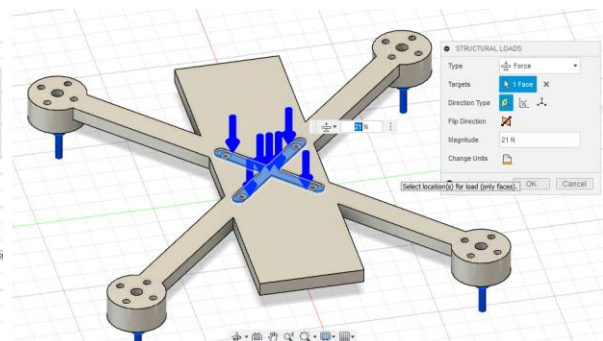

Fig 4 A payload of 21N is applied on the frame

C. Comparative analysis of basic design of quad copter frame made of Al, A356T6, ABS plastic

The Maximum displacement and Stress for Aluminium material is as shown as fig 5 and 6 respectively below.

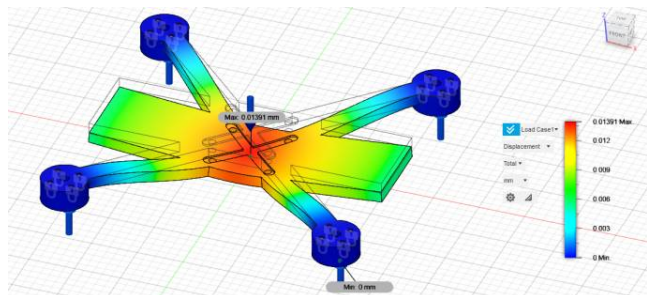

Fig 5 Maximum displacement

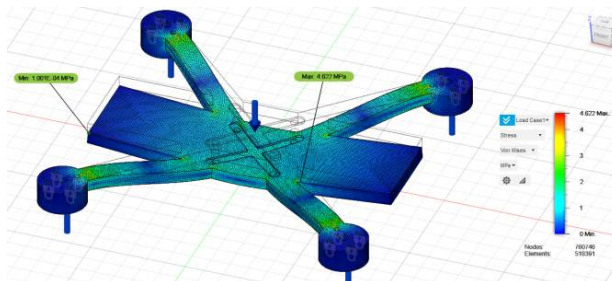

Fig 6 Stress distribution

Stress and maximum displacement for Al A356 T6 is as shown in fig 7 and 8 respectively

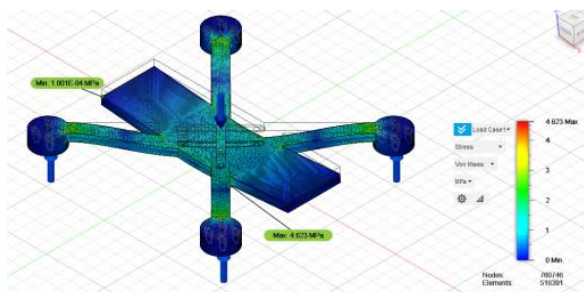

Fig 7 Stress distribution

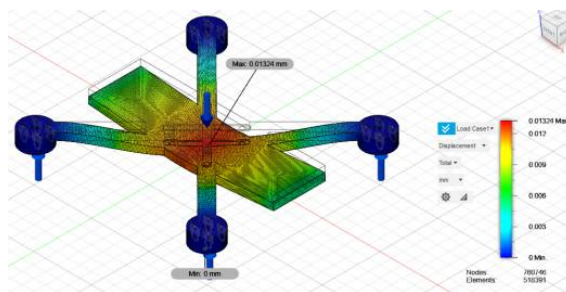

Fig 8 Maximum displacement

Stress and maximum displacement for ABS is as shown in fig 9 and 10 respectively

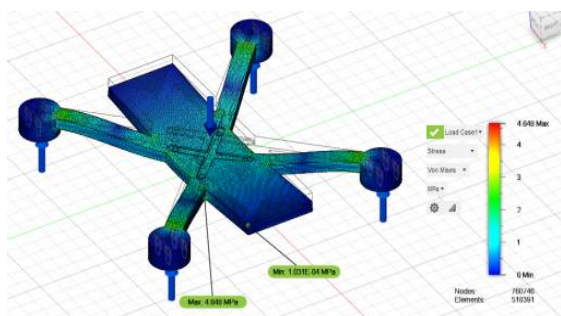

Fig 9 Stress distribution

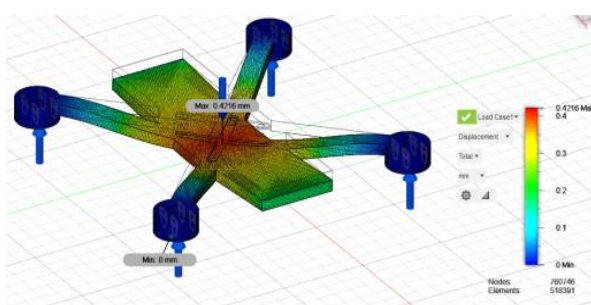

Fig 10 Maximum displacement

The following table no 3 compares the static stress analysis results of all three materials used.

Table 3 Comparison of static stress analysis results for Al, Al A356 T6 and ABS plastic of basic model

Property	Aluminium		Al A356 T6		ABS Plastic	
	Min	Max	Min	Max	Min	Max
Factor of Safety	15	15	15	15	4.303	15
Von Mises Stress MPa	1.001E-04	4.622	1.001E-04	4.623	1.031E-04	4.648
Displacement mm	0	0.01391	0	0.01324	0	0.4216
Reaction Force N	0	1.277	0	1.279	0	1.259
Strain	2.534E-09	1.072E-04	2.412E-09	1.02E-04	7.35E-08	0.003431

The ultimate factor of safety (FOS) used in aircraft can be about 1.5. In general, an FOS of 2 is considered as a standard for tested structures and 3 for untested structures. The most important thing in aircraft application is it should have the lowest weight possible [2]. The FOS based on yield strength of materials is 15 for Al as well as Al A356 T6 whereas for ABS plastic it is 4.303. Amongst other factors, it is mainly weight that has its impact on the FOS and the least weight is with ABS plastic as it is only 39.26% of the weight of Al and 39.7% of the weight of Al A356 T6. So, ABS plastic is chosen for further analysis such that the strength is not compromise while further reducing the weight of the frame using shape optimization technique.

V. SHAPE OPTIMIZATION AND STRESS ANALYSIS OF QUAD COPTER FRAME MADE OF ABS PLASTIC

A. Shape Optimization of Quad Copter Frame (Iteration 1)

Fusion 360 software is used to shape optimize the basic model of quad copter frame designed to bring out the best of the design. The following is the 1st iteration of the design to cut down mass and material. The 1st iteration is the basic model of the quad copter frame on which the boundary conditions and loads are applied as discussed in section 4.2. Shape optimization or otherwise topology optimization is applied to find the regions in the design component that does not contribute much to load or otherwise whose absence does not affect the strength, stiffness or rigidity of the component [17 to 23].

B. Analysis of Shape Optimized Quad Copter Frame

On simulating for optimizing shape of the basic model, the target is set to reduce mass by at least 30%. This is done by modifying the design in every iteration such that the design still meets the strength criteria. The 1st iteration is worked out on the basic model (fig 2), and the stress distribution is studied (Fig 11). The blue color region in fig. 11 shows that the region has negligible stress and that region is not contributing much in carrying the load and hence can be reduced. The basic model is redesigned keeping in mind the stress distribution and fig. 12 is the outcome whose weight came down to 76.75g.

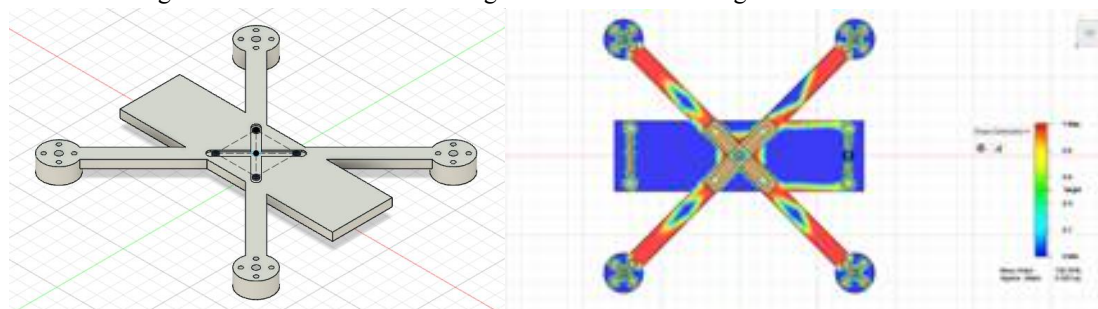

Fig 11 Iteration 1: a) Basic model of the quad copter frame b) Stress distribution on basic model quadcopter frame

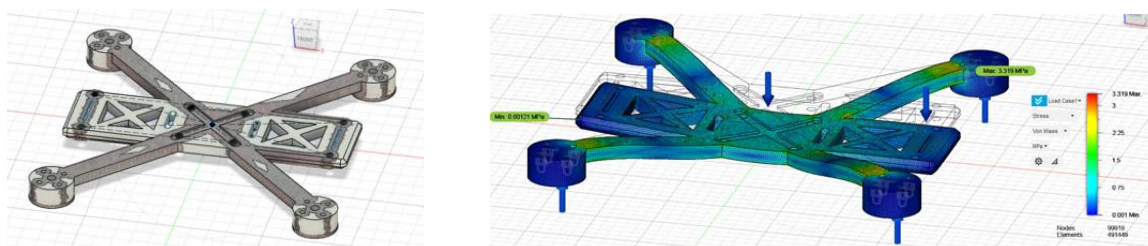

Fig 12 Iteration 2 a) shape optimized design b) stress analysis

On further applying shape optimization technique on fig. 12, fig. 13 is resulted. The weight of the final component is 54.54g with a 35% weight reduction. Lesser weight gives more flight time and payload capacity to the drone. The maximum stress in the final component after shape optimization is 3.238MPa and the minimum FOS is 6.39.

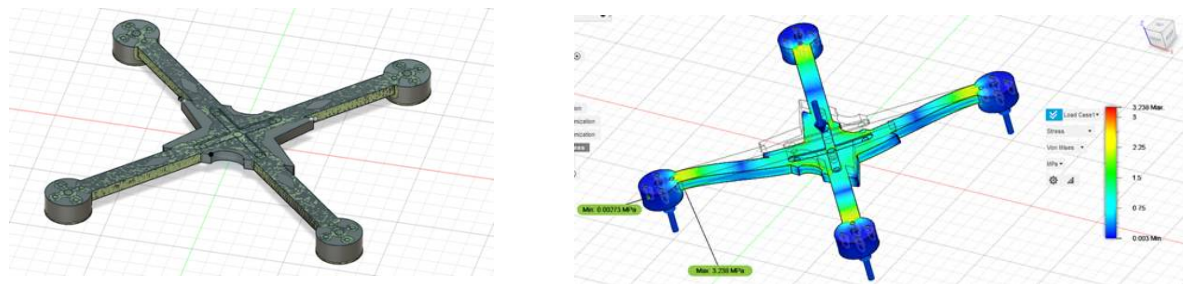

Fig 13 Iteration 2 a) shape optimized design b) stress analysis

VI.RESULT

After applying shape optimization technique on the basic design, the design properties and the static stress analysis results are tabulated as Table 4. From table 4 it is evident that the mass of the frame came down to 54.54g from 85.06g, ie. 35.88% of weight is reduced which is way more than the target set (ie. 30%) and with a minimum of factor of safety of about 6.39 which is also greater than the standard set (ie. 3) for the design.

Table 4 Comparison of static stress analysis results and design properties for SO I, SO II and SO X

Property	SO Iteration 1	SO Iteration 2	SO Iteration X
Mass g	85.06	76.75	54.54
Density g / mm ³	0.001	0.001	0.001
Volume mm ³	80244.84	72405.478	51452.701
Center of Mass mm	(0.00,0.00,2.189)	(0.00,0.004,2.098)	(0.005,0.001,1.736)
Moment of Inertia at Center of Mass (g mm ²)			
Ixx	1.705E+05	1.695E+05	1.654E+05
Iyy	2.602E+05	2.396E+05	1.672E+05
Izz	4.295E+05	4.080E+05	3.316E+05
Factor of Safety	4.303	6.026	6.39
Von Mises Stress MPa	4.648	3.319	3.13
Displacement mm	0.4216	0.4208	0.4821
Reaction Force N	1.259	3.358	3.768
Strain	0.003431	0.002277	0.002194

REFERENCES

- [1] Faiyaz Ahmed, J. C. Mohanta, Anupam Keshari, Pankaj Singh Yadav, Recent advances in Unmanned Aerial Vehicles: A Review, Arabian Journal for Science and Engineering, volume 47, pages 7963-7984 (2022) DOI: <https://doi.org/10.1007/s13369-022-06738-0>
- [2] John J. Zipay, C. Thomas Modlin Jr., Curtis E. Larsen, The ultimate factor of safety for aircraft and spacecraft – its history, applications and misconceptions, 57th AIAA/ASCE/AHS/ASC Structures, Structural Dynamics, and Materials Conference, 2016. <https://arc.aiaa.org/doi/10.2514/6.2016-1715>
- [3] Swapnil Yemle, Yogeshwar Durgude, Ganesh Kondhalkar, Ketan Pol, Design & Analysis of Multi-Frame for Octo & Quad Copter Drones, International Research Journal of Engineering and Technology, Volume: 06 Issue: 06, Page 2935- 2939
- [4] S. Meivel, S.Maheswari, Design and aluminium framework of drone using solidworks, International Journal of Grid and Distributed Computing, Vol. 12, No. 2, 2019, pg 85 to 97. <https://www.researchgate.net/publication/340594698>.
- [5] Puneeth Nagaraju Obli, Quad copter Frame Optimization, June 2020 <https://www.researchgate.net/publication/342038780>
- [6] Prajwalkumar M. Patil, Mallikarjun B. Koujalagi, Krishna Toli, Modeling, analysis & fabrication of quadcopter (uav) with payload drop mechanism, International journal of research in advent technology, Special Issue, March 2019, E-ISSN: 2321-9637, 2019. www.ijrat.org
- [7] Ali Magdi Sayed Soliman, Suleyman Cinar Cagan, Berat Baris Buldum, The design of a rotary-wing unmanned aerial vehicles–payload drop mechanism for fire-fighting services using fire-extinguishing balls, Springer Nature Switzerland AG 2019. <https://doi.org/10.1007/s42452-019-1322-6>
- [8] Muhammad A. Muflikhun, Elmer R. Magsino, Alvin Y. Chua, Design of a quadrotor uav aluminum casting frame, RCMME 2014. <https://www.researchgate.net/publication/272164971>
- [9] Ivan Palinkas, Jasmina Pekez, Eleonora Desnica, Aleksandar Rajic, Dorian Nedelcu, Analysis and Optimization of UAV Frame Design for Manufacturing from Thermoplastic Materials on FDM 3D Printer, Materiale Plastice, 58 (4), 2021, 238-249. <https://doi.org/10.37358/MP.21.4.5549>



- [10] MohamedZain, A.O.; Chua, H.; Yap, K.; Uthayasurian, P.; Jiehan, T. Novel Drone Design Using an Optimization Software with 3D Model, Simulation, and Fabrication in Drone Systems Research. *Drones* **2022**, *6*, 97. <https://doi.org/10.3390/drones6040097>
- [11] <https://www.foundationstructures.com/> for finding weight of all components used in drone
- [12] K. Anilkumar, K. Sumanth, B. Kishore, T. Kondalarao, N. Jagadeesh, Analysis of quadcopter, *International Journal of Engineering Science and Computing*, March 2019, pp 20358 – 20361. <http://ijesc.org/>
- [13] <https://www.modalai.com>
- [14] <https://robu.in>
- [15] M Urdea, Stress and vibration analysis of a drone, *IOP Conference Series: Materials Science and Engineering*, 2021. doi:10.1088/1757-899X/1009/1/012059
- [16] Swarna Uma Maheswara Chary, B.Purna Chandra Sekhar, Design and optimization of drone jammer antenna using structural analysis, *Journal of interdisciplinary cycle research*, Volume XII, Issue XI, November/2020, Issn no: 0022-1945, Page No: 425 to 430
- [17] Yee Ling Yap , William Toh , Anthoni Giam , Feng Rong Yong , Keen Ian Chan , Justin Wei Sheng Tay , Soo Soon Teong , Rongming Lin , Teng Yong Ng , Topology Optimization and 3D Printing of Micro-Drone: Numerical Design with Experimental Testing, *International Journal of Mechanical Sciences* (2022). <https://doi.org/10.1016/j.ijmecsci.2022.107771>
- [18] Sung Hoon Chung , Bhawesh Sah , Jinkun Lee, Optimization for drone and drone-truck combined operations: A review of the state of the art and future directions, *Computers and Operations Research* 123 (2020). <https://doi.org/10.1016/j.cor.2020.105004>
- [19] Nagadurga Srinivas Sripada, A methodology for topology and lattice structure optimization of a cargo drone motor mount, 2018. <https://rc.library.uta.edu/uta-ir/handle/10106/27218>
- [20] Ali Ahrari, Ali A. Atai, Fully Stressed Design Evolution Strategy for Shape and Size Optimization of Truss Structures, *Computers and Structures* 123 (2013) pg 58–67. <http://dx.doi.org/10.1016/j.compstruc.2013.04.013>
- [21] T.R.Costa, M. P. Caldas, P. M. N. Araujo, E. C. Silva, Topological Optimization applied towards the development of a small and lightweight MAV composite frame, 10th International Micro-Air Vehicles Conference November 2018. <http://www.imavs.org/pdf/imav.2018.7>
- [22] Sven Maricic, Iva Mrsa Haber, Ivan Veljovic, Ivana Palunko, Implementation of optimum additive technologies design for unmanned aerial vehicle take-off weight increase, *Eureka: Physics and Engineering*. <https://doi.org/10.21303/2461-4262.2020.001514>
- [23] Mohammad Shaqura, Jeff S. Shamma, An Automated quadcopter cad based design and modeling platform using solidworks api and smart dynamic assembly, 14th International conference on informatics in control, Automation and Robotics 2017- Volume 2, pp 122-131. <https://doi.org/10.5220/0006438601220131>



10.22214/IJRASET



45.98



IMPACT FACTOR:
7.129



IMPACT FACTOR:
7.429



INTERNATIONAL JOURNAL FOR RESEARCH

IN APPLIED SCIENCE & ENGINEERING TECHNOLOGY

Call : 08813907089  (24*7 Support on Whatsapp)