



# Design and Analysis of Triple Notched Band Uwb Band Pass Filter Using Defected Microstrip Structure (Dms)

Satish Chand Gupta, Mithilesh Kumar, Ram Swaroop Meena

Department of Electronics Engineering, Rajasthan Technical University, Kota, India

## Email address:

satishggc@yahoo.co.in (S. C. Gupta), mith\_kr@yahoo.com (M. Kumar), rssmeena@gmail.com (R. S. Meena)

## To cite this article:

Satish Chand Gupta, Mithilesh Kumar, Ram Swaroop Meena. Design and Analysis of Triple Notched Band Uwb Band Pass Filter Using Defected Microstrip Structure (Dms). *International Journal of Wireless Communications and Mobile Computing*.

Vol. 5, No. 6, 2017, pp. 32-44. doi: 10.11648/j.wcmc.20170506.11

**Received:** December 19, 2017; **Accepted:** January 2, 2018; **Published:** January 19, 2018

---

**Abstract:** This paper presents design, simulation, fabrication and electrical analysis of a triple notched band UWB band pass filter. Short circuit stubs and microstrip line defected structures are used to design a triple notched band UWB filter. The proposed UWB BPF consists of five short circuited stubs of quarter wavelength attached to the feed line. The notched bands are created by introducing three U-shaped defected microstrip structures in the feed line. The proposed structure of the filter is designed, simulated on CST MSW and fabricated using conventional photolithography process. This band pass filter is designed to pass the UWB signals between 3.1 GHz to 10.6 GHz and to eliminate INSAT signal (4.6 GHz), WLAN signal (5.6 GHz) and satellite communication signal (8.0 GHz). The experimental results of this fabricated filter are compared with the simulated results and they are found to be in close agreement to each other. The Electrical equivalent circuit of this triple notched band filter is also presented in this paper and verified mathematically. This filter is compact in size and better in performance. It can be incorporated in UWB communication system to efficiently increase the interference protection from undesired signals. The physical dimension of this filter is about 30x10.5 mm<sup>2</sup>.

**Keywords:** Ultra-Wide Band (UWB), Defected Microstrip Line Structure (DMS), WLAN, Multi-Mode Resonator (MMR), Federal Communication Commission (FCC), WiMAX, INSAT

---

## 1. Introduction

Ultra-wide band (UWB) from 3.1 GHz to 10.6 GHz is released by the Federal Communications Commission for commercial use of indoor and hand-held wireless systems in 2002 [1]. High mobility, flexibility and high data rate are the attractive features of UWB radio system which draws interest from scientists and engineers. An Ultra-wide band pass filter is an important passive element to realize such a wide band radio system. Therefore designing such a wide band filter is much in demand. In order to obtain UWB characteristics; researchers have designed UWB filters using various techniques such as follows: MMR [2-3], meander resonator; inter digital coupled lines with modified multi-mode ring resonator [4-5], short circuited stubs with non-redundant connecting lines [6], defected microstrip structure [7], defected ground structure in [8-9], three parallel coupled lines with a radial open stub in [10], short circuited stubs separated by uniform connecting lines [11].

In the UWB frequency range, some frequency bands which are allotted for specific functions such as WiMAX (3.5 GHz), INSAT C (4.5 GHz), WLAN (5.6 GHz) and satellite communication band (8.0 GHz) signals, may create interference with UWB systems. Therefore, UWB band pass filters with multiple notched bands are needed to eliminate these unwanted interfering signals. Lot of research has been done in the field of design and manufacturing of this type of filters. To achieve single notched band various techniques were reported in [12-19]. Band stop filters were realized by various methods with different configuration in [12], application of DGS and embedded stubs in [13-14], L-shaped open stubs and ring resonator and stub-loaded MMR with electrical coupling were used in [15-16]. For designing of dual notched bands many methods were demonstrated in [17-20]. C-shaped DGS in multi-layer structure [17], modified L-shaped resonator in [18], dual embedded open-circuited stubs with stub-loaded rectangular ring MMR in [19] and multi-mode resonator with dual spur-line [20] were used to design

double notched band UWB filter. To design and implement a triple notched band filter various techniques were described in [21-23]. Creation of transmission zeroes with a double MMR structure in [21], triple-mode stepped impedance resonator (SIR) with modified genetic algorithm (MGA) in [22] and a combination of multimode resonators (MMR) and complementary split ring resonators (CSRR) were used to design multi notch-bands ultra wide-band (UWB) band-pass filters (BPF) in [23].

DGS and DMS are two important techniques which are used to produce narrow sharp stop band frequency response. DMS is easier to integrate with other microwave circuits and effectively reduced the circuit size compared to DGS. It exhibits the properties of a slow wave and it rejects the electromagnetic waves at certain frequencies by controlling the electrical length of the circuit. DMS does not change the geometry of the ground plane and helps to avoid leakage of radio frequency signals. Therefore, DMS has been widely used for designing band stop filter at microwave frequencies. Many researchers have used this idea of DMS to obtain notch band as demonstrated in [24-29].

In this paper, design and analysis of UWB BPF filter with triple notched bands using defected microstrip structure (DMS) is presented. Five short circuited stubs of quarter wavelengths are interconnected by a single feed line is used to design a basic UWB BPF [30]. Later on multiple defected microstrip structures are embedded in the feed line to obtain a multi notched band filter. Here three U-shaped defected microstrip structures are used to generate a notched band in the filter response. The number of notches that are generated in the response signal is directly related with the number of DMSs and the frequency of the notch is the function of the profile dimension of the DMS. The proposed UWB filter is designed using commercial, full-wave electromagnetic (EM) simulation software CSTMWS, and is fabricated on the substrate FR4 of dielectric constant 4.4 and height 1.6 mm.

The novelty of this paper is that the fabrication of the proposed filter is easy, compact in size and cost of the substrate used is comparatively low. The methodology used to design this filter is verified by solving the electrical equivalent circuit of this filter.

The structure of this paper is as follows. In section 2, the comparison between simulation and experimental data is presented. Section 3 demonstrates the electrical modelling of this filter. In section 4, electrical analysis of filter and is described. Finally, the conclusions are mentioned in Section 5.

## 2. Design of UWB Filter with Notch Bands

Initially a five poles UWB BPF filter is designed by five short circuited stubs of quarter wavelengths based on Chebychev proto type low pass filter with 0.1 dB pass band ripple. The admittances and dimension of the stubs are calculated by using design equation which is given below [12].

$$\theta = \frac{\pi}{2} \left( 1 - \frac{FBW}{2} \right) \quad (1)$$

$$\frac{J_{1,2}}{Y_0} = g_0 \sqrt{\frac{hg_1}{g_2}} \quad (2)$$

$$\frac{J_{i,i+1}}{Y_0} = \frac{hg_0 g_1}{\sqrt{g_i g_{i+1}}} \text{ for } i=2 \text{ to } n-2 \quad (3)$$

$$Y_{i,i+1} = Y_0 \left( \frac{J_{i,i+1}}{Y_0} \right) \text{ for } i=1 \text{ to } n-1 \quad (4)$$

$$N_{i,i+1} = \sqrt{\left( \frac{J_{i,i+1}}{Y_0} \right)^2 + \left( \frac{hg_0 g_1 \tan \theta}{2} \right)^2} \quad (5)$$

for  $i=1 \text{ to } n-1$

$$Y_1 = g_0 Y_0 \left( 1 - \frac{h}{2} \right) g_1 \tan \theta + Y_0 \left( N_{1,2} - \frac{J_{1,2}}{Y_0} \right) \quad (6)$$

$$Y_i = Y_0 \left( N_{i-1,i} + N_{i,i+1} - \frac{J_{i-1,i}}{Y_0} - \frac{J_{i,i+1}}{Y_0} \right) \quad (7)$$

for  $i=2 \text{ to } n-1$

Where  $h$  is the dimensional constant and  $n$  is the number of poles which are fixed to a value for providing a convenient admittance level of the filter.

For this proposed filter we take  $h=1.7$  and  $n=5$ , stubs and line admittances calculated from the formulas mentioned in equations from 1 to 7 and dimensions calculated from SERENIDE S. V 8.5 are given in Table 1.

**Table 1.** Design parameters of basic UWB filter.

Stub admittance	Calculated admittance of S/C stub in (mho)	Dimension of stub in mm	
		Length	Width
Y1	0.007536	6.7	0.35
Y2	0.008304	6.7	0.42
Y3	0.008759	6.7	0.56
Y4	0.009094	6.7	0.42
Y5	0.007536	6.7	0.35

In the basic structure of the filter, three horizontal U-shaped DMS slots of quarter wavelength are etched on the 50 ohms microstrip line which is shown in figure 1. Defected microstrip structure (DMS) perturbs current distribution on the surface of the microstrip line and modifies the properties of the transmission line. The increment in the effective inductance and capacitance introduces stop band characteristics in the frequency response. The arrangement of these DMSs is shown in figure 2. The dimensions of the DMSs are given by length ( $l_1$ ,  $l_2$  &  $l_3$ ), coupling gaps between these resonators ( $l_{12}$  &  $l_{23}$ ), width of resonators (a) and spacing gap (b) of resonators.

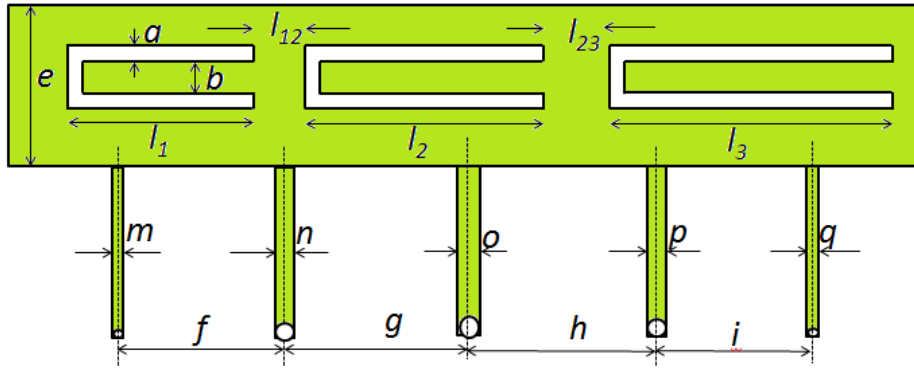

Figure 1. Structure of filter design.

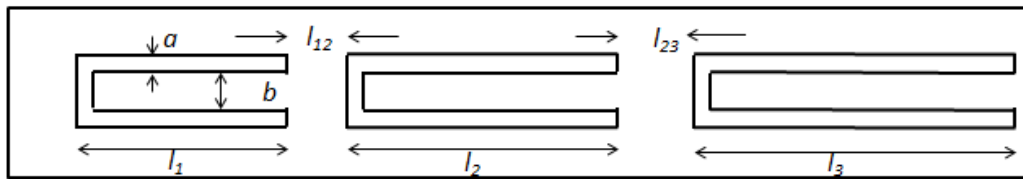

Figure 2. Arrangement of defected microstrip structure (DMS).

The notch frequency is determined by the dimensions of the DMS. It is more sensitive towards the length of the resonator which can be obtained as shown below:

$$f_{notch} = \frac{c}{\lambda_{notch} \sqrt{\epsilon_{eff}}} \tag{8}$$

$$l = \frac{\lambda_{notch}}{4} \tag{9}$$

C=Speed of Light in free space ( $3 \times 10^8 \text{ m/s}$ ),

$\epsilon_{eff}$  is effective dielectric constant of the substrate used.

$$l = \frac{46.07}{f_{notch}} \tag{10}$$

Calculation of respective lengths of DMS are shown in Table 2.

Table 2. Calculation of length of DMS.

$f_{1notch} = 8.0\text{GHz}$	$f_{2notch} = 5.6\text{GHz}$	$f_{3notch} = 4.6\text{GHz}$
$l_1 = 5.7\text{mm}$	$l_2 = 8.2\text{mm}$	$l_3 = 10.0\text{mm}$

(While other parameters are kept constant at  $a = b = 0.2 \text{ mm}$  and  $l_{12} = l_{23} = 2.0 \text{ mm}$ ).

The structure parameters of the filter shown in figure 1 are  $a = 0.2 \text{ mm}$ ,  $b = 0.2 \text{ mm}$ ,  $l_{12} = 2.00 \text{ mm}$ ,  $l_{23} = 2.00 \text{ mm}$ ,  $e = 3.2 \text{ mm}$ , length of short circuit stub  $l = 6.7 \text{ mm}$   $f = g = h = i = 6.9 \text{ mm}$  (Spacing between short circuit stubs),  $l_1 = 5.7 \text{ mm}$ ,  $l_2 = 8.2 \text{ mm}$  and  $l_3 = 10.0 \text{ mm}$  (length of U-shaped DMS),  $m = q = 0.35 \text{ mm}$ ,  $n = p = 0.42 \text{ mm}$ ,  $o = 0.56 \text{ mm}$  and diameter of the short circuit via hole is considered to be  $0.3 \text{ mm}$ . The proposed structure of the filter shown in the figure 1 is

simulated by using electromagnetic simulator CST MWS software.

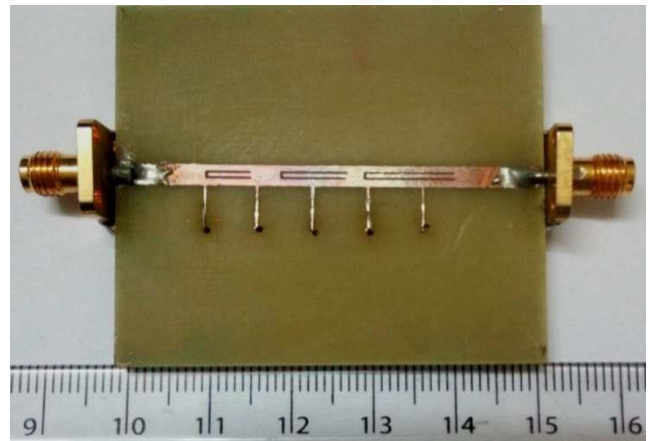

Figure 3. Photograph of fabricated filter with triple notched band.

Finally, the proposed filter is fabricated by photolithography process and the picture of the fabricated filter is shown in figure 3. The s-parameters of the fabricated filter are measured on Agilent Tech. E5071C ENA Vector Network Analyzer. Comparison between the simulated and measured results is in consensus with each other as is shown in figure 4. The measured response of the filter shows pass band from 3.1 to 10.6 GHz and three highly rejected notched bands centered at 4.6 GHz, 5.6 GHz and 8.0 GHz with rejection level -15.0 dB, -20.0 dB and -20.2 dB at these notch frequencies. The 3-dB fractional bandwidth of 1.96%, 1.75% and 1.12% are also observed from the result. The value of insertion loss ( $S_{21}$ ) of approximate value is 0.41 dB, 0.35 dB, 0.20 dB and 0.25 dB in band I<sup>st</sup>, II<sup>nd</sup>, III<sup>rd</sup> and IV<sup>th</sup> band respectively. The slight divergence in the measurement and simulation results

is caused due to imperfection in fabrication, quality of substrate and SMA connectors used. The design of our filter is compared with similar filters (dielectric constant, size of the filter, number of notch bands, pass band etc.) and

comparison is given in Table 3.

It is observed that the performance of the triple notched band UWB filter using DMS has better and uniform insertion loss in the pass band.

**Table 3.** Comparison of proposed work with various multi band UWB BPF'S.

No. of Ref.	$\epsilon_r$ /height	Size (mm <sup>2</sup> )	Notch frequency/attenuation (dB)	Pass Band (GHz)	Year of Publication
[33]	3.38/1.527	20*19.5	4.2 and 7.7/>20	3.0-8.5	2017
[34]	3.38/0.508	20*15	6/>20	3.6-10.1	2016
[35]	2.2/0.508	35.66*13.15	5.2/6.8/8.0/>10	3.1-10.9	2015
[36]	2.65/1.0	30*16	5.3/7.8/>20	2.8-11.0	2014
[37]	2.55/0.8	22.5*13.7	5.5/>10	3.1-10.6	2013
[38]	2.2/1.0	31*20	3.6/5.9/8.0/>10	3.1-10.6	2013
This work	4.4/1.6	30.0*10.0	4.6/5.6/8.0/>15	3.1-10.6	-

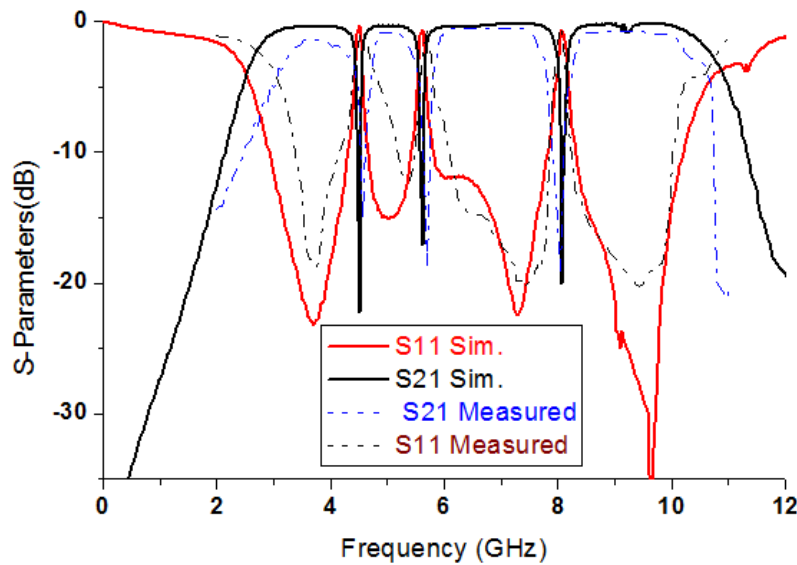
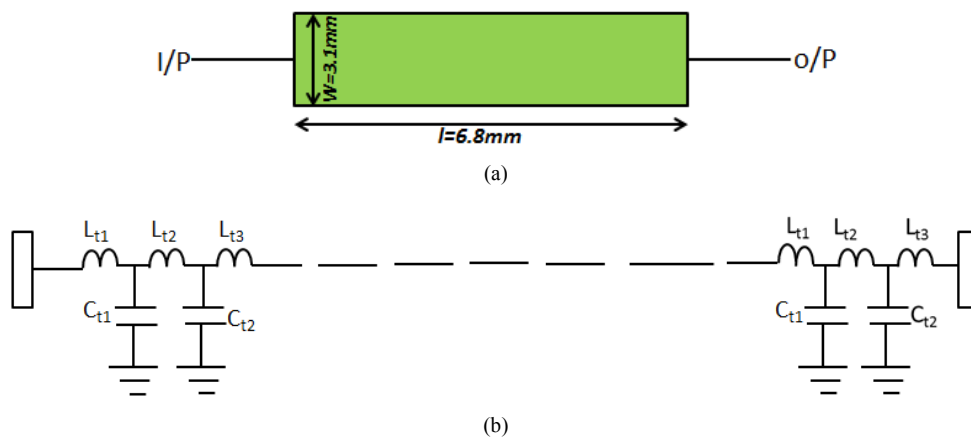

**Figure 4.** Comparison of S-parameters of designed UWB filter with triple notched band.

### 3. Electrical Analysis of the Proposed Filter

The structure of the filter shown in Figure1 consists of 50 ohms feed line, quarter wavelength short circuited stub and defected microstrip structure (DMS). Electrical analysis of this filter can be explained by making an individual

equivalent circuit consisting of the components of the filter. The microstrip line of 50 ohm is represented by distributed R- L-C-G network, but at very high frequency the line behaves as loss less line so it is represented by L-C parameters. The electrical equivalent circuit of a small section 50 ohm feed line is shown figure 5. The electrical equivalent of quarter wavelength short circuited stub and DMS is described in the following sections.



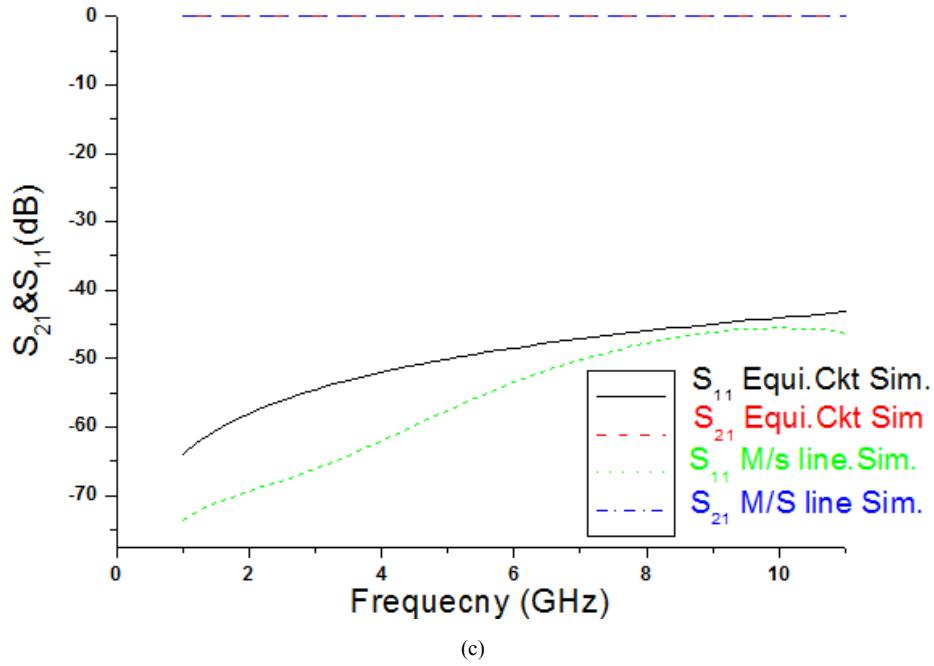

Figure 5. (a) Small section of feed line (b) Electrical equivalent circuit of feed line for values  $Lt1=0.21 \text{ nH}$ ,  $Lt2=0.35 \text{ nH}$ ,  $Lt3=0.39 \text{ nH}$ ,  $Ct1=0.71 \text{ pF}$ ,  $Ct2=0.12 \text{ pF}$ , (c) Comparison of response.

3.1. Electrical Equivalent of Quarter Wavelength Short Circuited Stub

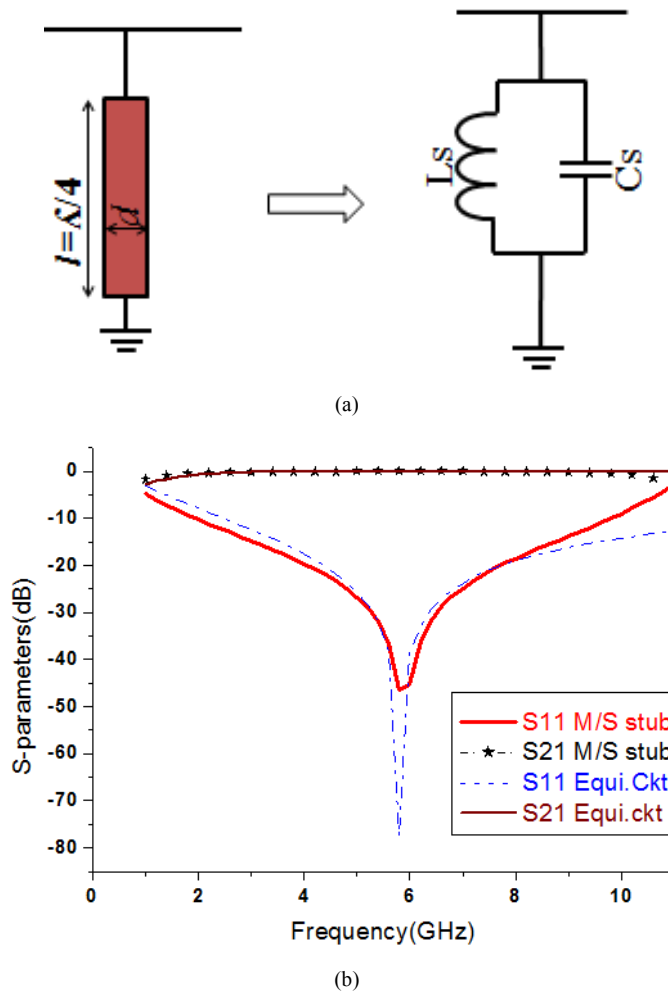

Figure 6. (a) Microstrip line stub and its equivalent circuit (b) Comparison of response ( $Ls=3.96 \text{ nH}$  and  $Cs=0.22 \text{ pF}$ ).

Five short circuited stubs in the proposed structure of the filter create five poles in the frequency response. A short circuit stub of quarter wavelength can be represented by parallel L-C circuit and the values of L and C of individual stub is calculated by the use of standard equations in [31]. A microstrip line short circuited stub of quarter wave length is simulated on an EM simulator. The simulation results are compared with its equivalent L-C circuit simulation response which is shown in figure 6.

**3.2. Electrical Equivalent Circuit of DMS**

In the microstrip line circuit; defected ground plane

**Table 4.** Equivalent circuit parameter calculation of DMS.

$f_0=4.6$	$f_c=4.545$ and $4.655$	$f_0=5.6$	$f_c=5.56$ and $5.64$	$f_0=8.0$	$f_c=7.998$ and $8.16$
$L_{d1}$	$C_{d1}$	$L_{d2}$	$C_{d2}$	$L_{d3}$	$C_{d3}$
0.08147	15.85	0.0638	12.52	0.0437	9.0

$$C \approx \frac{1.59f_c}{(f_0^2 - f_c^2)} pf \text{ and } L \approx \frac{25}{f_c^2 C} nH .$$

( $f_0, f_c$  are in GHz) where  $f_0$  is frequency of resonance while  $f_c$  is cut of frequency.

Simulation responses of a DMS of length 8.2 mm for a notch band frequency 5.6 GHz and its equivalent L-C network circuit is compared and shown in figure 7.

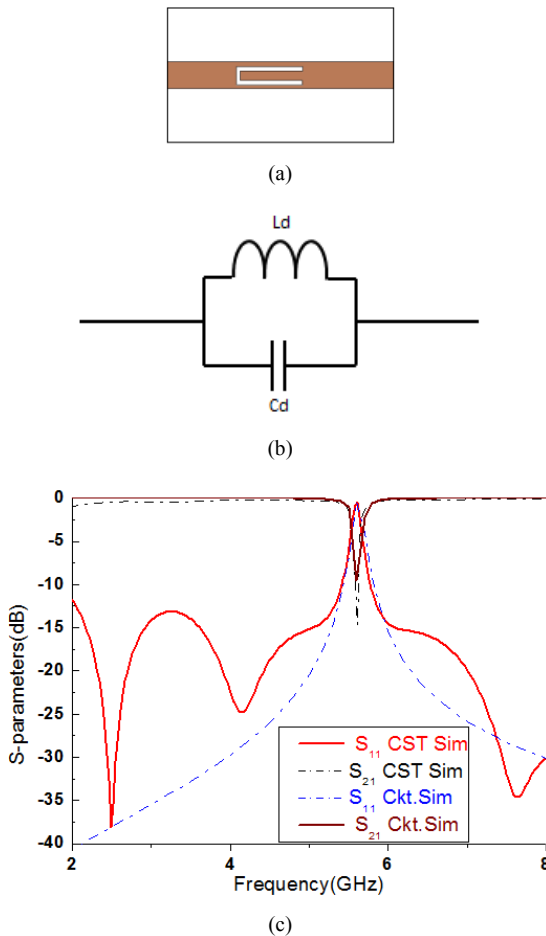
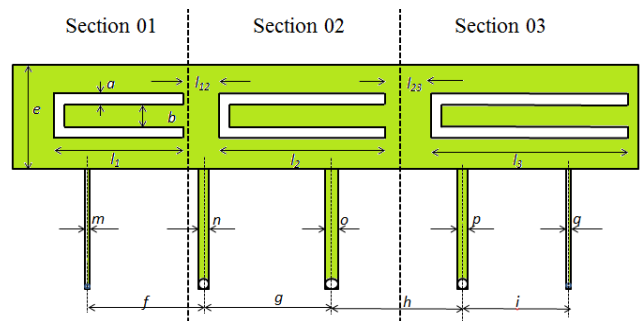

**Figure 7.** (a) DMS structure (b) Equivalent circuit of DMS (c) Comparison of response for  $L_d=0.064nH$  and  $C_d=12.52pF$ .

structures and defected microstrip structures are very useful techniques to reduce the size of the circuit for a given frequency response. Defect in the ground plane, arises the problem of radiation, which can be overcome by using DMS in place of DGS. Introducing DMS in the microstrip line circuit disturbs the current distribution and increases the effective value of the inductance and capacitance of the line. This behavior of the DMS is electrically explained by a parallel L-C circuit [32]. The inductance and capacitance of DMS are frequency sensitive and can be calculated by using the formulae shown in Table 4.

**4. Analysis of the Proposed Filter**

The filter structure shown in figure 1, having three defected microstrip structures which behave as resonators are closely placed on a 50 ohms line and an electrical coupling between these resonators affects the performance of the filter. This filter structure can be analysed by dividing it into sections. The frequency response of the electrical equivalent circuit of individual section is compared with CST simulation frequency response. The overall electrical equivalent circuit is made by combining the individual section's equivalent circuits. This filter structure is divided into three sections as named as section 01, section 02 and section 03 which is shown in figure 8.

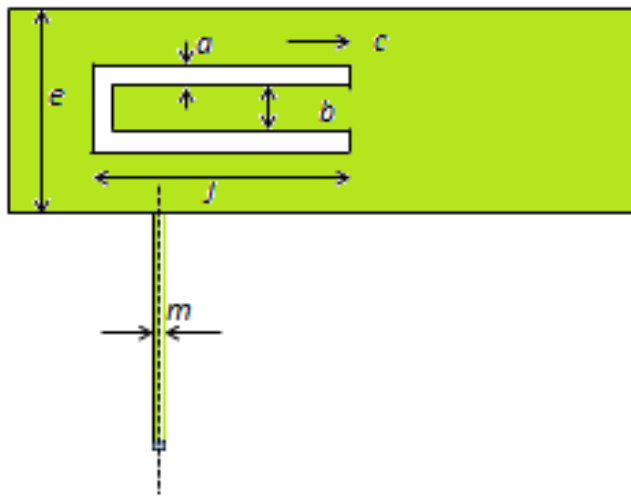

**Figure 8.** Section wise division of the filter structure.

**4.1. Analysis of Section 01**

Section 01 consists of one DMS, one QWSS and 50 ohms microstrip line. The analysis of this section is mentioned in figure 9. Figure 9 (a) represents the CST model of this section and its electrical equivalent is shown in figure 9 (b). This equivalent electrical circuit is simulated on a EM circuit simulator (SERENIDE SV 8.5) and its frequency response is compared with the CST simulation results. Figure 9 (c)

shows that the results are in agreement with each other.



(a)

Equivalent circuit of 50Ω M/S line

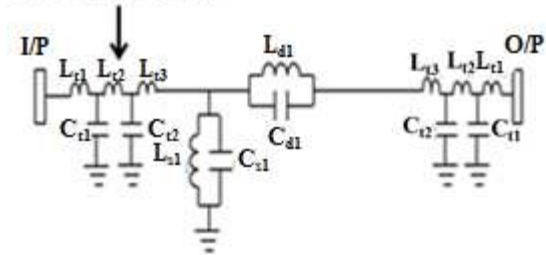

(b)

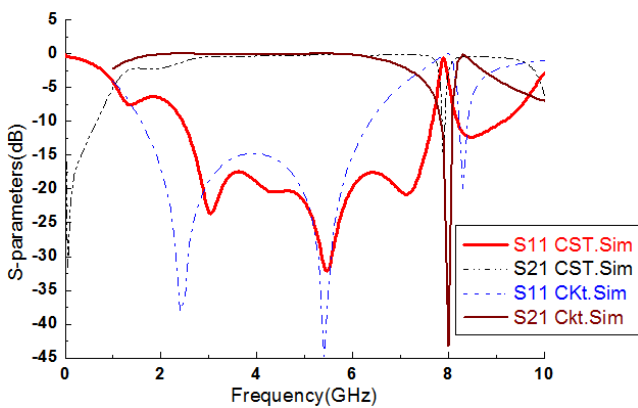

(c)

**Figure 9.** (a) CST modal of section 01 (b) Electrical equivalent of section 01 (c) Comparison of frequency responses for values  $L_{s1}=3.94$  nH,  $C_{s1}=0.22$  pF,  $L_{d1}=0.044$  nH and  $C_{d1}=9$  pF.

The letters in subscription with L and C stands for, t=transmission line parameters, s=short circuit stub parameters and d=defected microstrip structure parameters.

**4.2. Analysis of Section 02**

The analysis of section 02, consists of two QWSS and one DMS and 50 ohms microstrip line. It's CST model, electrical equivalent circuit and comparison of frequency responses are shown in figure 10.

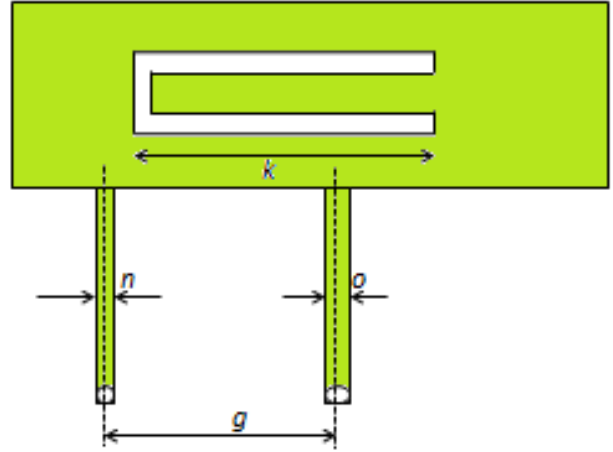

(a)

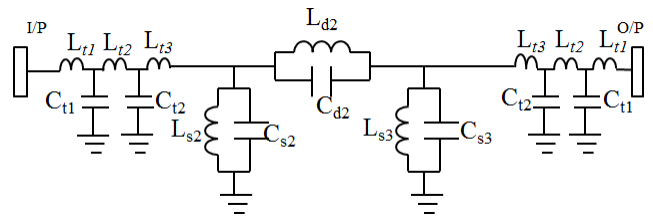

(b)

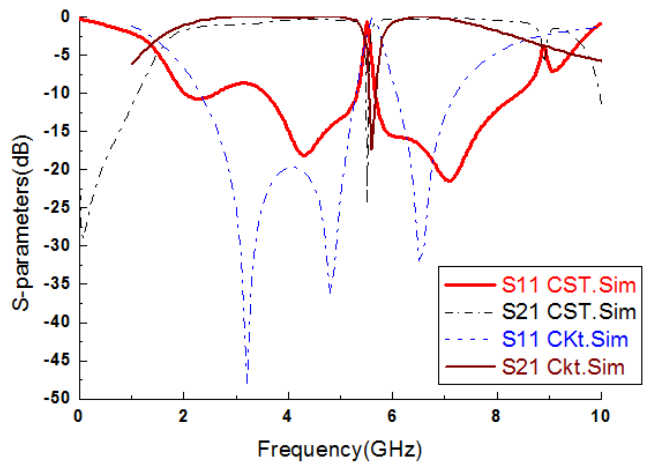

(c)

**Figure 10.** (a) CST model of section 02 (b) Electrical Equivalent of sections 02 (c) Comparison of frequency response for parameters  $L_{s2}=3.64$ nH,  $C_{s2}=0.24$ pF,  $L_{d2}=0.064$ nH,  $C_{d2}=12.52$ pF  $L_{s3}=3.4$ nH and  $C_{s3}=0.26$ pF.

**4.3. Analysis of Section 03**

The section 03 of the proposed structure consists of the remaining two QWSS, one DMS and a 50 ohms microstrip line. The CST model, electrical equivalent circuit and comparison of frequency responses of section 03 are shown in figure 11.



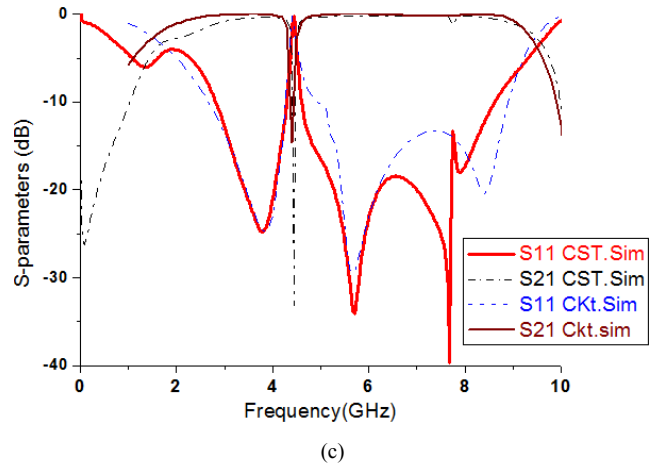
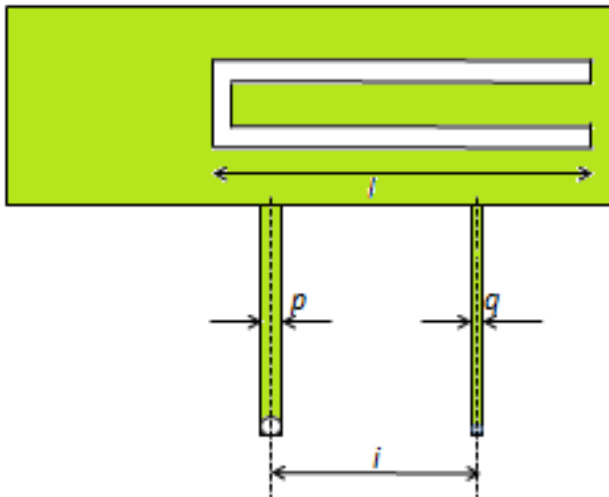
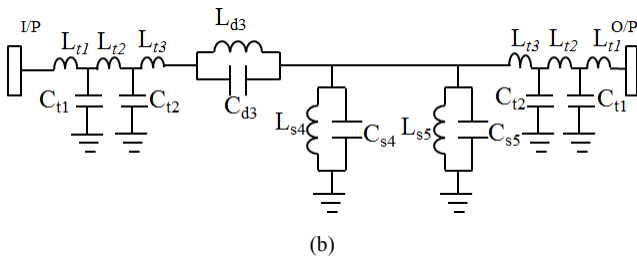

Figure 11. (a) CST modal of section 03 (b) electrical equivalent of section 03 (c) Comparison of frequency response for values  $Ls4=3.64nH$ ,  $Cs4=0.24pF$ ,  $Ls5=3.96nH$ ,  $Cs5=0.22pF$ ,  $Ld3=0.082nH$  and  $Cd3=15.85 pF$ .



For better understanding of the notched filter behaviour; the surface current distribution at three different frequencies of 8 GHz, 5.6 GHz and 4.6 GHz are observed as shown in figure 12. These frequencies correspond to the the center frequencies of the three notched bands. At the notched frequencies, current distribution is concentrated along the DMS which verifies that the resonance at frequencies 8 GHz, 5.6 GHz and 4.6 GHz are as provided by the DMSs.

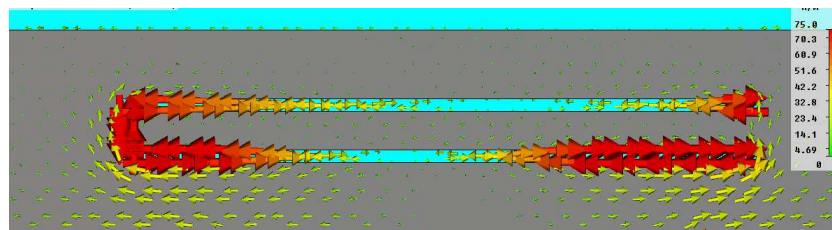
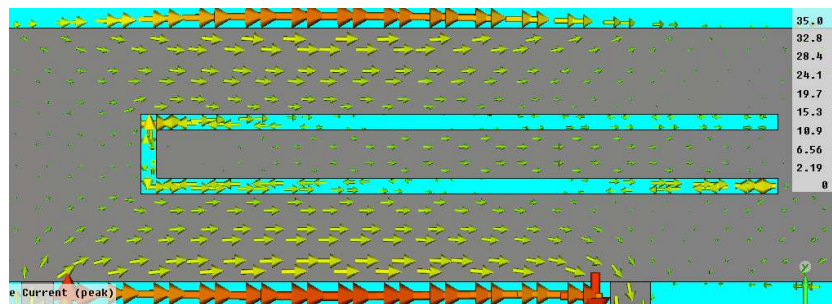
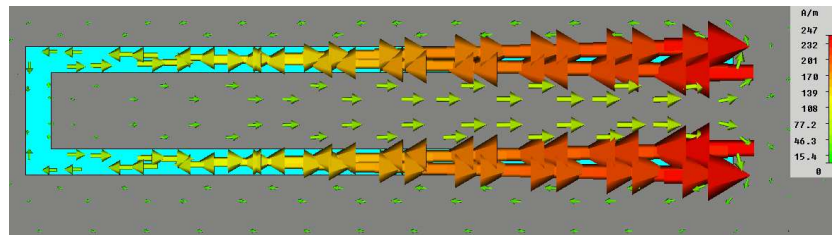

Figure 12. Surface current distribution in DMS at three different frequencies (a) Front side at 8.0 GHz (b) Front side at 5.6 GHz (c) Front side at 4.4 GHz.



**4.4. Overall Electrical Equivalent Circuit of the Filter**

The overall electrical equivalent circuit of the proposed filter structure which is shown in figure 13 can be obtained by combining the equivalent circuits explained in figure 8, 9 and 10. This circuit is simulated by SERENIDE SV 8.5 circuit simulator and its frequency response is compared with CST simulation frequency response. This comparison is shown in figure 14.

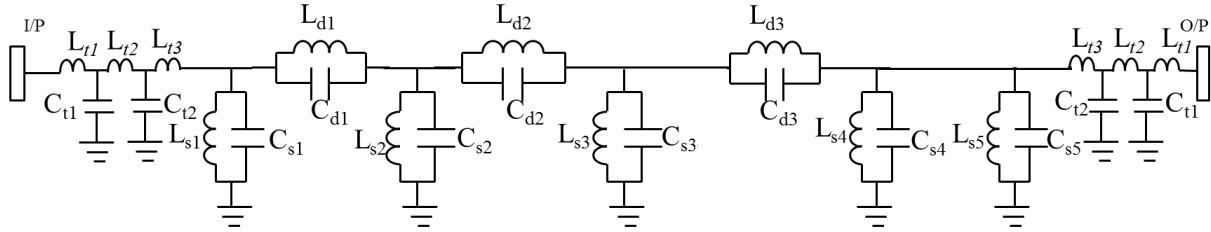

Figure 13. Electrical equivalent circuit of the filter.

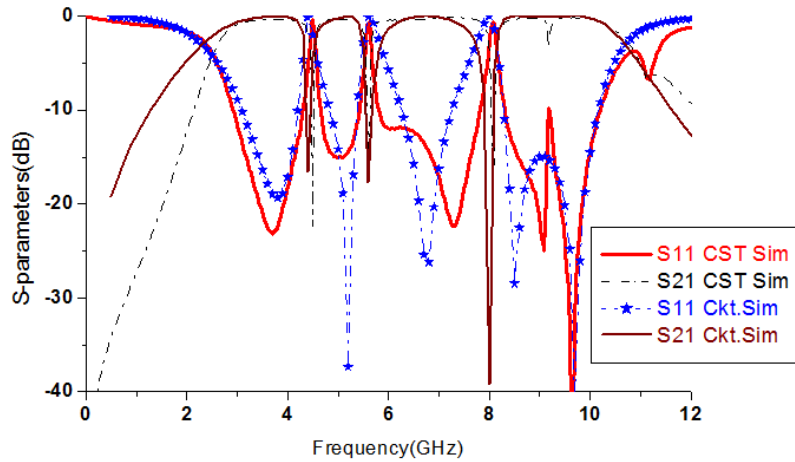

Figure 14. Comparison of frequency response.

This comparison of frequency response shows close resemblance and it verifies that the circuit shown in figure 13 is the electrical equivalent circuit of the proposed structure of the filter.

**4.5. Mathematical Analysis of This Proposed Filter**

The electrical equivalent circuit shown in figure 13 can be mathematically verified by solving this electrical network using circuit theory. Over all ABCD parameters of this circuit are calculated by calculating ABCD parameters of the individual sections. The calculated ABCD parameters of overall network are converted into S-parameters by using the following equations:

$$\begin{bmatrix} A & B \\ C & D \end{bmatrix}_{overall} = \begin{bmatrix} A & B \\ C & D \end{bmatrix}_{section01} \begin{bmatrix} A & B \\ C & D \end{bmatrix}_{section02} \begin{bmatrix} A & B \\ C & D \end{bmatrix}_{section03} \tag{11}$$

$$S_{11} = \frac{A + BY_0 - CZ_0 - D}{A + BY_0 + CZ_0 + D} = \frac{\Delta_1}{\Delta} \tag{12}$$

$$S_{21} = \frac{2}{A + BY_0 + CZ_0 + D} = \frac{2}{\Delta} \tag{13}$$

Where  $Y_0 = \frac{1}{Z_0}$  and  $Z_0 = 50\Omega$

$$S_{11} \text{ (dB)} = 20 \log_{10} |S_{11}| \tag{14}$$

$$S_{21} \text{ (dB)} = 20 \log_{10} |S_{21}| \tag{15}$$

The expression of the S-parameters in terms of frequency obtained from equation 7 and 8 is solved using MATLAB. This frequency response is compared with CST simulation response and the equivalent circuit simulation response is shown in figure 15. The resemblance in the results is shown in figure 15. This verifies the equivalent model of the proposed filter.

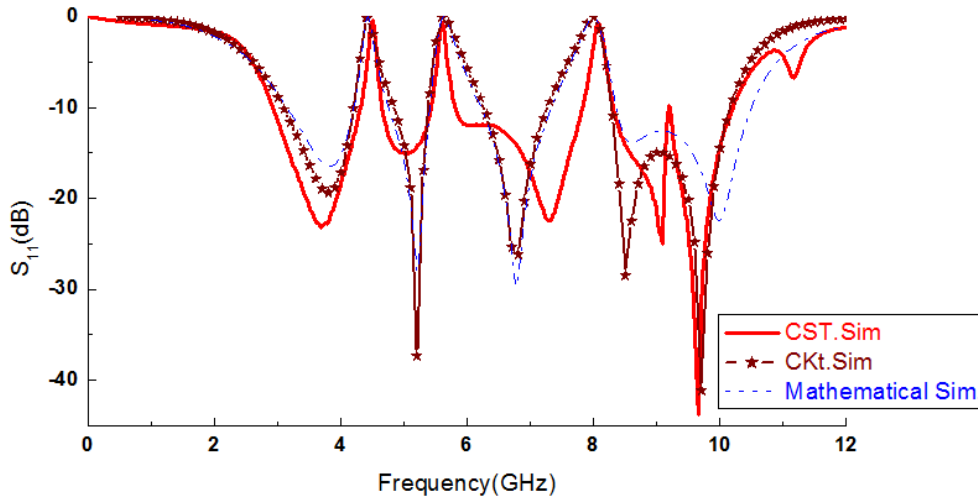

(a)

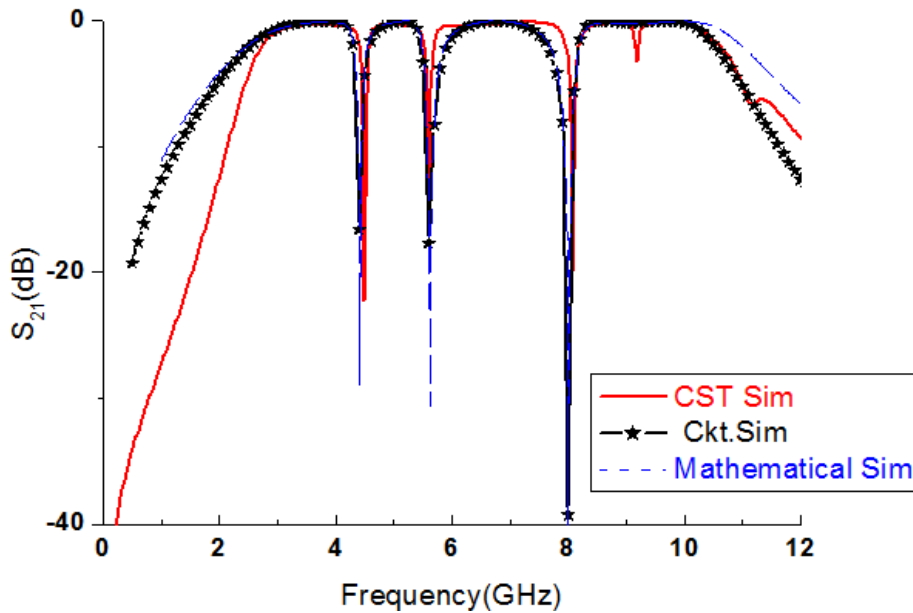

(b)

Figure 15. Comparison of results (a) Return loss  $S_{11}$  (b) Insertion loss  $S_{21}$ .

4.6. Parameter Characterization of the Filter

In the proposed filter structure DMS resonator creates notch band, therefore the parameters of DMS resonator i.e length ( $l$ ), width ( $b$ ) and spacing ( $a$ ) affects the characteristics of the notch band in the frequency response of the filter. The study of parameter characterization is carried out by considering a U-shaped DMS which provide notch band at 5.4 GHz shown in figure 16.

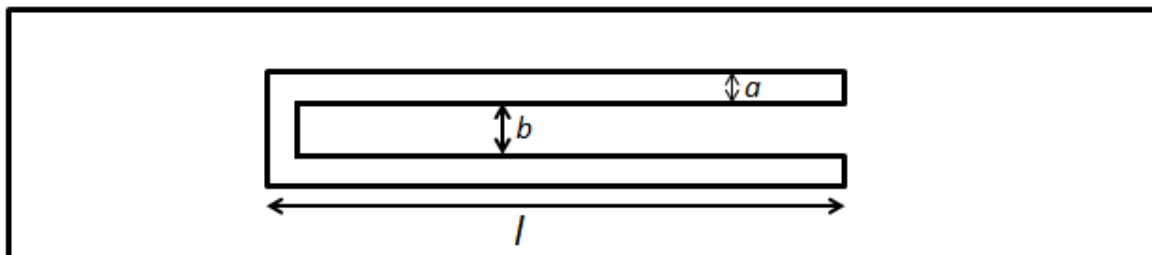

Figure 16. U-shaped DMS.

One parameter of DMS is varies while other kept constant and structure is simulated and effect of this change in the parameter is observed in the frequency response which is shown in figure 17. These observations from simulation are illustrated in Table 5. It is observed that the length of the DMS is the effective parameter to control the location of the notch in comparison to other parameters. The notch frequency decreases with increasing the length of the resonator. It is observed that the notch frequency slightly decreases with increasing width of the DMS and variation in the spacing of the resonator does not affect the notch frequency of the filter.

Table 5. The ( $f_{notch}$ ) against parameter variation.

Parameter dimensions in mm	Length ( $l$ )			Spacing ( $a$ )			Width ( $b$ )		
	7.0	8.0	9.0	0.1	0.2	0.3	0.5	1.0	1.5
$f_{notch}$ (GHz)	6.21	5.46	4.87	5.43	5.46	5.475	5.53	5.4	5.26

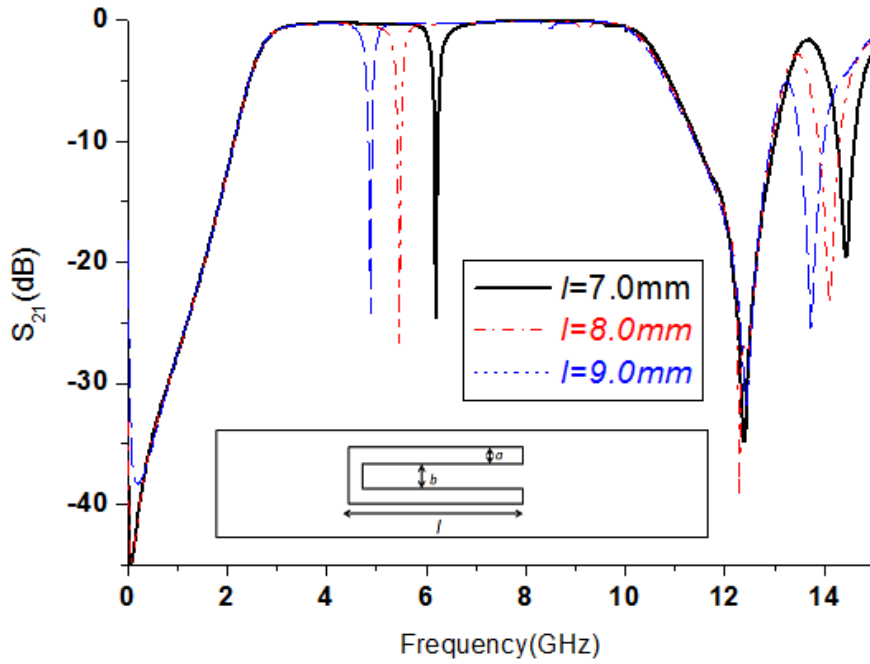

Figure 17. Effect of variation in length of DMS while ( $a=0.2\text{mm}$  and  $b=1.0\text{mm}$  are constant).

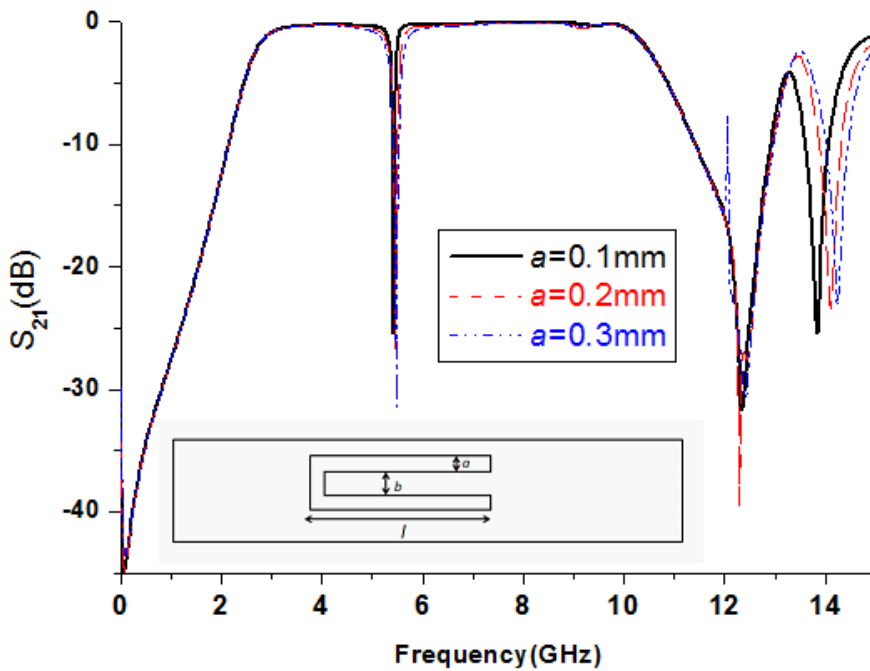

Figure 18. Effect of variation in spacing of DMS while ( $l=8.0\text{ mm}$  and  $b=1.0\text{ mm}$  are const.).

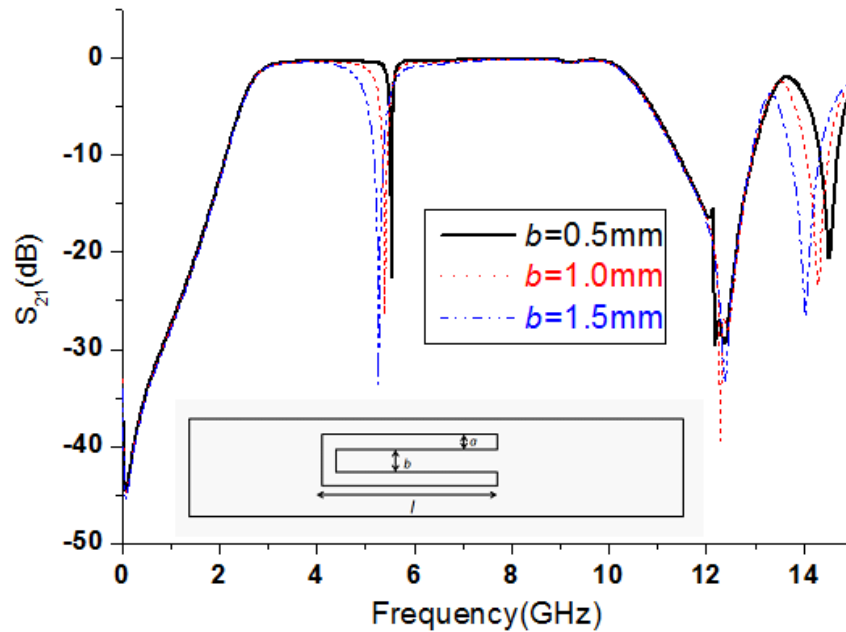

Figure 19. Effect of variation in width of DMS while ( $l=8.0$  mm and  $a=0.2$  mm are const.).

## 5. Conclusions

A microstrip UWB BPF with three highly rejected notched bands has been proposed in this paper. Initially the basic UWB filter is designed by using quarter wavelength short circuited stubs connected with the feed line. Then three quarter wave length U-shaped slots are incorporated in the feed line of the basic UWB filter structure to achieve three notched bands. Three notch bands are easily generated and their centre frequency is controlled by varying the length of the U-shaped resonator. For demonstration the UWB BPF is designed, simulated and fabricated. The measured value parameters show close resemblance with the predicted value parameters. The electrical analysis of this filter is also reported in this paper. Therefore the proposed filter is useful for wireless communication systems as it is easy to fabricate, comparatively compact in size and is far superior in performance.

## References

- [1] FCC, Revision of part 15 of the commission's Rules regarding Ultra-wideband Transmission Systems, Federal Communications Commission, Tech, Rep, ET-Docket 98-153, FCC 02-48, Apr. 2002.
- [2] Zhu, L. S. Sun, and W. Menzel, "Ultra-wideband (UWB) band pass filters using multiple-mode resonator," *IEEE Microw. Wireless Compon. Lett.*, Vol. 15, No. 11, pp. 796–798, 2005.
- [3] R. Li and L. Zhu, "Compact UWB band pass filter using stub-loaded multiple-mode resonator," *IEEE Microw. Wireless Compon. Lett.*, Vol. 7, No. 1, pp. 40–42, 2007.
- [4] Tianliang Zhang, Liguozhou, Kai Yang, Wei Dang, Kezhao Hua, Changlin Yang, Peng Chen, "Compact multi-mode UWB microstrip filter using meander resonator," *Microwave and Optical Technology Letters*, Vol. No. 58, pp. 2026-29, 2016.
- [5] Yong-Qin Liu and Xi-Zheng Ke, "A Novel Compact Microstrip UWB Band pass Filter with Improved Out-of-Band Rejection," *Progress In Electromagnetics Research Letters*, Vol. 59, pp. 21–25, 2016.
- [6] Hussein Shaman and Jia-Sheng Hong "An Optimum Ultra-Wideband (UWB) Band pass Filter with Spurious Response Suppression," *WAMICON 2006*.
- [7] Fallahzadeh, S. and M. Tayarani, "A new microstrip UWB band pass filter using defected microstrip structure," *Journal of Electromagnetic Waves and Application*, Vol. 4 No. 7, pp. 893-902, 2010.
- [8] Arjun Kumar and M. V. Kartikeyan, "Design and realization of microstrip filters with new defected ground structure (DGS)," *Engineering Science and Technology, an International Journal*, Vol. 20, No. 2, pp. 679-86, 2017.
- [9] Naghshvarian-Jahromi, M. and M. Tayarani, "Miniature planar UWB band pass filters with circular slots in ground," *Progress in Electromagnetics Research Letters*, Vol. 3, pp. 87-93, 2008.
- [10] Yechou Lahcen, Tribak Abdelwahed, Kacim Mohamed, Zbitou Jamal, and Angel Mediavilla Sanchez, "A Novel Low-Cost Microstrip Band pass Filter for Ultra-Wideband RF Applications," *International Journal of Microwave and Optical Technology*, Vol. 11, No. 2, March 2016.
- [11] Abdel-Fattah Sheta and Ibrahim Elshafiey, "Microstrip Ultra-Wide-Band Filter," *PIERS Proceedings*, Marrakesh, MOROCCO, March 20-23, 2011.
- [12] Hong, J. S. and M. J. Lancaster, *Microstrip Filters for RF/Microwave Application*, Wiley, New York, 2001.
- [13] Yang, G.-M., R. Jin, C. Vittoria, V.-G. Harris, and N.-X. Sun, "Small ultra-wideband (UWB) band pass filter with notched band," *IEEE Microw. Wireless Compon. Lett.*, Vol. 18, No. 3, pp. 176–178, 2008.

- [14] Shaman, H. and J.-S. Hong, "Ultra-wideband (UWB) band pass filter with embedded band notch structures," *IEEE Microw. Wireless Compon. Lett.*, Vol. 17, No. 3, pp. 193–195, Mar. 2007.
- [15] A. Kalteha, Atila Eskandarnejad, "Design of a Novel Compact Microstrip UWB Band-pass filter with 5.5 GHz band rejection function," *Indian J. Sci. Res.* pp. 113-116, 2014.
- [16] Tengfei Yana, Xiao-Hong, and Tanga, Jun Xiangb, "High-selectivity UWB band-pass filter with a notched band using stub-loaded multi-mode resonator," *AEU - International Journal of Electronics and Communications* Vol. 70, Issue 12, pp. 1617-1621, 2016.
- [17] P.-Y. Hsiao and R.-M. Weng, "Compact tri-layer Ultra-Wideband Band-Pass Filter with dual notch bands," *Progress In Electromagnetics Research*, Vol. 106, pp. 49-60, 2010.
- [18] L. Bala Senthil Murugan, S. Antony Anbu Raja, "Design and Implementation of a Microstrip Band-Stop Filter for Microwave Applications," *International conference on modeling, optimization and computing, Elsevier, Procedia Engineering* pp. 1346 – 1351, 2012.
- [19] Hung-Wei Wu and Yu-Fu Chen, "Ultra wideband band pass filter with dual-notched bands using stub-loaded rectangular ring multi-mode resonator" *Microelectronics Journal*, Vol. 43, Issue 4, pp. 257-62, 2012.
- [20] Hung-Wei Wu and Yu-Fu Chen, "New compact ultra wideband band pass filter using modified multi-mode resonator" *AEU - International Journal of Electronics and Communications*, Vol. 66, Issue 12, pp. 1021-25, 2012.
- [21] Anil Kamma, Ranjan Das, Darshak Bhatt, and Jayanta Mukherjee, "Multi-Mode Resonators Based Triple Band Notch UWB Filter," *IEEE Microwave and Wireless Components Letters*, Vol. 27, Issue: 2, 2017.
- [22] Chengpei Tang and Nian Yang, "Design of Compact Microstrip UWB Band pass Filter with Triple-Notched Bands," *Progress In Electromagnetics Research Letters*, Vol. 58, pp. 9–16, 2016.
- [23] Omid Borazjani, Mehdi Nosrati and Mojgan Daneshmand, "A novel triple notch-bands ultra wide-band band-pass filters using parallel multi-mode resonators and CSRRs," *International Journal of RF AND MICROWAVE COMPUTER-AIDED ENGINEERING*, Vol. 24, Issue 3, pp. 375-81, 2014.
- [24] Vijaykrishnan J. and Ravi Prakash Dwivedi, "Analysis of different shapes of defected microstrip structure (DMS) and their stop-band performance" *ARPJ Journal of Engineering and Applied Sciences* Vol. 10, No. 8, 2015.
- [25] Jian-Kang and Xiao Yu-Feng Zhu, "Multi-band band stop filter using inner T-shaped defected microstrip structure (DMS)" *AEU - International Journal of Electronics and Communications*, Vol. 68, Issue 2, February 2014, Pages 90–96.
- [26] S. Allahzadeh and M. Tayarani, "A New microstrip UWB band pass filter using defected microstrip structure" *J. of Electromagn. Waves and Appl...* Vol. 24, pp 893-902, 2010.
- [27] Tao Jiang, Yanyan Wang and Ying Song Li "Design and Analysis of a Triple Stop-band Filter Using Ratioed Periodical Defected Microstrip Structure" *Frequenz Journal of RF-Engineering and Telecommunications*, June 2016.
- [28] Hussein Shaman and Jia-Sheng Hong "Ultra-wideband (UWB) Microstrip Band pass Filter with Narrow Notched Band" *Proceedings of the 38th European Microwave Conference EuMA* pp. 857-60, 2008.
- [29] Jianpeng Wang, Junding Zhao and Jia-Lin Li, "Compact UWB band pass filter with triple notched bands using parallel U-shaped defected microstrip structure," *Electronics Letters* Vol. 50, Issue: 2, 2014.
- [30] Satish Chand Gupta, Mithilesh Kumar and R. S. Meena "Design of UWB filter based on multi short circuited stubs" *IEEE Conference RAECS*, 2014.
- [31] Koryn Ishii T. Handbook of microwave technology, component & devices, Vol. 01 Academic Press; 2013, pp. 123-124.
- [32] J.-K. Xiao and W.-J. Zhu, "New Defected Microstrip Structure Band stop Filter" *Progress In Electromagnetics Research Symposium Proceedings*, pp. 12-16, 2011.
- [33] Arjun Kumar, M. V. Kartikeyan "Design and realization of microstrip filters with new defected ground structure (DGS)," *Engineering Science and Technology, an International Journal* Volume 20, pp. 679-686, 2017.
- [34] Shan, Q., C. Chen, and W. Wu, "Design of an UWB band pass filter with a notched band using asymmetric loading stubs," *IEEE International Conference on Microwave and Millimeter Wave Technology (ICMMT)*, Vol. 2, pp. 5–8, 2016.
- [35] Ruifang Su, Ting Luo, Wenlan Zhang, Junding Zhao, and Zifei Liu "A New Compact Microstrip UWB Band pass Filter with Triple-Notched Bands," *Progress In Electromagnetics Research C*, Vol. 60, pp. 187–197, 2015.
- [36] Song, Y., G. M. Yang, and G. Wen, "Compact UWB band pass filter with dual notched bands using defected ground structures," *IEEE Microwave and Wireless Components Letters*, Vol. 24, No. 4, pp. 230–232, 2014.
- [37] Zhu, H. and Q. X. Chu, "Ultra-wideband band pass filter with a notch-band using stub-loaded ring resonator," *IEEE Microwave and Wireless Components Letters*, Vol. 23, No. 7, pp. 341–343, 2013.
- [38] Wei, F., Z. D. Wang, F. Yang, and X. W. Shi, "Compact UWB BPF with triple-notched bands based on stub loaded resonator," *IEEE Electronics Letters*, Vol. 49, No. 2, pp. 124–126, 2013.