

Design and Development of the ATLAS Central Solenoid Magnet

A. Yamamoto, T. Kondo, Y. Doi, Y. Makida, K. Tanaka, T. Haruyama, H. Yamaoka
High Energy Accelerator Research Organization (KEK), Tsukuba, Ibaraki, 305-0801, Japan

H. ten Kate, L. Bjorset
European Laboratory for Particle Physics (CERN), CH-1213, Geneva, Switzerland

K. Wada, S. Meguro, The Furukawa Electric Co. Ltd., Nikko, Tochigi, 321-1493, Japan

J.S.H. Ross, and K.D. Smith, Oxford Instruments, Oxford, OX2 0DX, England

Abstract ---The ATLAS central solenoid magnet is being constructed to provide a magnetic field of 2 Tesla in the central tracking part of the ATLAS detector. As a key technology for the solenoid coil as thin as possible, high-strength aluminum stabilized superconductor has been developed with achieving a yield strength of > 100 MPa at 4.2K. This paper describes the status of the design and development of the solenoid magnet.

I. INTRODUCTION

The ATLAS central solenoid magnet is being constructed as a collaborative work between KEK and CERN for the ATLAS experiment in the LHC project [1]-[3]. The solenoid is required to provide a axial magnetic field of 2 Tesla in a warm-bore of 2.3 m in diameter for precise momentum measurement of charged particles produced in 14 TeV proton-proton interactions at LHC. Figure 1 shows a bird's-eye view of the ATLAS central solenoid.

Since the coil is placed in front of the liquid-argon (LAr) electromagnetic calorimeter, the solenoid coil must be as thin (and transparent) as possible for the best calorimeter performance with minimum interactions of elementary particles in the coil. The solenoid coil design is featured with high-strength aluminum stabilized super-conductor to make the solenoid coil thinnest while keeping its electrical stability. As a further effort, the solenoid coil is installed in a common

vacuum vessel with the LAr calorimeter to minimize the wall material. Since the magnetic return yoke is located enough away, the coil is designed to be an iron-free, air-core solenoid. Fig. 2 shows the cross sectional view of the solenoid coil installed in the LAr calorimeter cryostat. This paper describes progress in design and fabrication of the ATLAS central solenoid magnet.

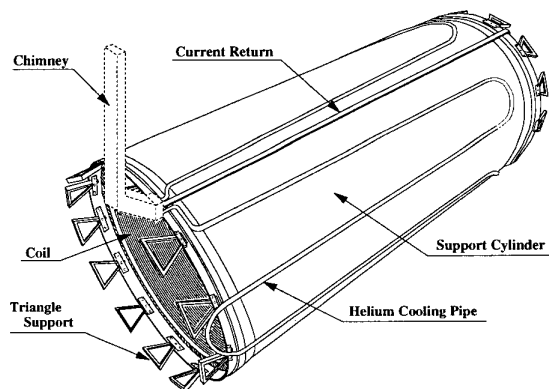

Fig. 1. Schematic view of the ATLAS central solenoid.

Manuscript received on Sept. 14, 1998

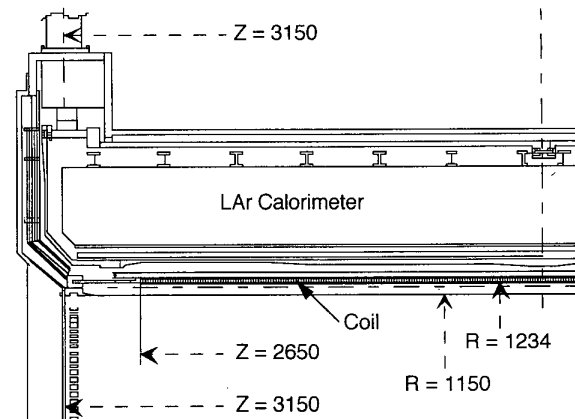

Fig. 2. Cross section of the coil, LAr calorimeter, and the common cryostat.

II. MAGNET DESIGN

A. Superconducting Coil

The ATLAS central solenoid magnet was designed with the following guide-lines [4], [5].

- Single layer coil with edge-wise winding, inside the coil support cylinder
- Mechanically elastic design with a stress intensity level of 70 MPa, with keeping a strain ≤ 0.1 %,
- Magnetic stored energy fully absorbable in the coil, with keeping a coil temperature ≤ 120 K, in a quench,
- Thin coil with $\leq 0.7 X_0$ (radiation thickness) optimized with an E/M (stored energy/coil mass) ratio of 7-8 kJ/kg,
- Indirect cooling by using two-phase helium flow.

Design parameters of the solenoid magnet are summarized in Table I, and the transparency breakdown is given in Table II.

TABLE I
DESIGN PARAMETERS OF THE ATLAS CENTRAL SOLENOID.

Dimensions (@ 300 K):		
Warm bore Inner radius		1,150 mm
Coil Inner radius		1,234 mm
Half length		2,650 mm
Transparency:		
Radial length of coil (90 deg.)		0.66 λ_0
Interaction length of coil (90 deg.)		0.13 λ_0
Electrical:		
Central field		2.0 T
Current		7,600 A
lop/lc on load-line at 4.2 K		45 %
Inductance		1.35 H
Stored energy		39 MJ
E/M ratio		7.1 kJ/kg
Magnetic force:		
Hoop stress in coil		47.5 MPa
Axial stress in coil		23.6 MPa
Radial de-centering force		<25 kN/cm
Axial de-centering force		<2 kN/cm
Coil weight		5.5 tons
Thermal load at 4.2 K:		
Coil (static+eddy-current-loss)		15 + <80 W
Chimney and control dewar		30 W

TABLE II
TRANSPARENCY OF THE ATLAS SOLENOID COIL

material	effective. thickness	λ_0	λ_0
Al-stabilizer	25.2 mm	0.283	0.067
NbTi/Cu	3.26	0.204	0.022
GFRP (Insulation)	3.0	0.017	0.007
Al-strip	1.2	0.013	0.003
Support cylinder	12.8	0.144	0.034
total		0.66	0.13

Figure 3 shows the cross section of the coil. The necessary coil thickness, t , to support the radial magnetic pressure, may be given by $t = r \cdot p / \sigma_h$, where r is the coil radius, p is the magnetic pressure, and σ_h is the hoop stress in the coil. Since it is proportional to " r " and B^2 , we may consider a useful parameter to scale the transparency of the superconducting coil in terms of the ratio of the stored energy, E , to the coil cold mass, M . This ratio can be simplified by:

$$E/M = \{B^2/2\mu_0 \cdot V_r\} / \{v_c \cdot \rho\} \approx \sigma_h / 2\rho,$$

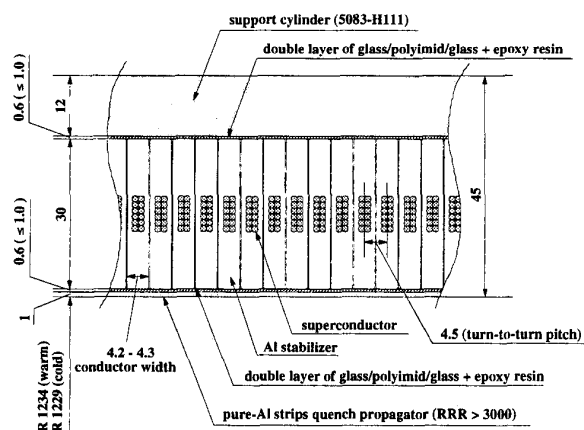

Fig. 3. Cross section of the ATLAS solenoid coil.

where $V_r (= \pi r^2)$ is the magnetic field volume per length, μ_0 is the permeability, $v_c (= 2\pi r t)$ is the coil volume per length, and ρ is the effective density of coil material. In case of the air-core solenoid having additional axial stress component corresponding to a half level of the hoop stress, the stress intensity ($\sigma_{SI} = \sigma_h - \sigma_z = 1.5 \sigma_h$) should be additional constraint to be enough below yield strength ($YS_{0.2}$) in the mechanically elastic design. Figure 4. shows the E/M ratio in various superconducting solenoid magnets for particle detectors in high energy physics. In the ATLAS solenoid, an E/M ratio of 7.1 kJ/kg is expected in operation in the ATLAS detector (and 8 kJ/kg in the magnet performance test at $I_{max} = 8,400$ A in air). Our previous experience in the SDC-prototype solenoid has already demonstrated the E/M ratio of about 10 kJ/kg including full energy dump test, and the ATLAS solenoid design should be safe enough [6].

The E/M ratio is also approximately equal to the coil enthalpy and is related to the coil temperature when the stored energy is dissipated entirely and uniformly in the coil after quench as follows:

$$E/M = \int C_p dT \approx H(T),$$

where C_p is the specific heat of the coil (aluminum), $H(T)$ is enthalpy of the coil at the temperature T after a quench. The E/M ratio of 7 kJ/kg corresponds to $T = 75$ K and the coil is thermally safe enough, even including some non-uniform temperature distribution in the coil. The uniform energy dump can be realized by using a quench propagator of pure-aluminum axial strips. This technique was established in the previously developed coils [6,7]. In the ATLAS central solenoid, pure (99.9998 %) aluminum strips of 10 cm in width and 1.2 mm in thickness are glued onto inner surface of the coil [8]. The maximum coil temperature was expected to be less than 120-K by using pure aluminum quench propagator with $RRR > 3,000$., as given in Table III.

B. Cooling of the magnet

The solenoid coil is cooled indirectly by using two-phase helium flow [9]. A helium cooling tube with an inner

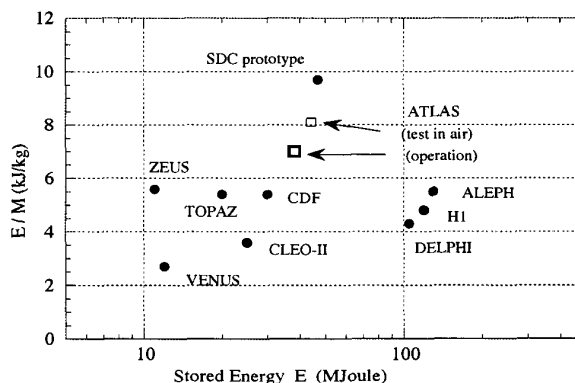

Fig. 4. E/M Ratios in various detector solenoid.

TABLE III
PEAK COIL TEMPERATURE AFTER QUENCH

RRR of pure-Al strip	Decay time	T-peak
1500	30 sec	134 K
2000	24	130
3000	23	120
4000	23	116

diameter of 18 mm is welded to the outer surface of the support cylinder. It has a pair of 6 parallel serpentine paths from the bottom to the top of the support cylinder. A forced flow of two-phase helium is taken in steady state operation. A thermosyphon cooling is prepared for a back-up. Figure 5 shows operational cryogenics characteristics in a temperature-entropy (T-S) diagram in He thermodynamics.

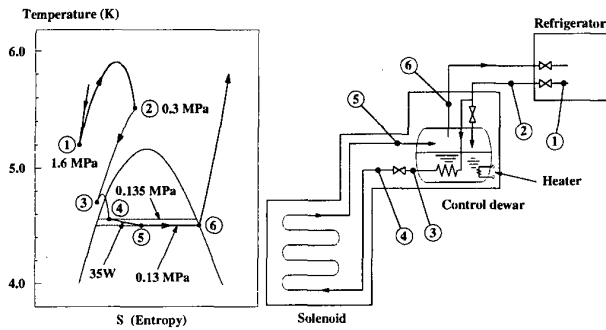

Fig. 5. The cryogenics flow diagram and characteristics.

III. FABRICATION

A. Superconductor

The superconductor consists of Rutherford type NbTi/Cu superconducting cable and aluminum stabilizer, as shown in Fig. 6. A half of the superconductor has been fabricated by the Furukawa Electric Co. Ltd., and another half is being fabricated by Hitachi Cable Co. Ltd. The critical current characteristics are shown in Fig. 7. Design parameters and measured performance by Furukawa are given in Table IV.

An extensive R&D effort has been made to improve the mechanical strength of aluminum stabilized superconductor while keeping adequate residual resistance ratio (RRR) [10]. The following process has been established;

- Micro-alloying: pure(5N)-Al alloyed with additives,
- Mechanical cold work: area reduction.

As a result of the development, the yield strength of 110 MPa (at RRR = 592) was achieved by using an additive of Ni (1000-ppm) in combination of a cold work of 21 % [11]. The measured mechanical strength is given in Table V. The stress-strain curve of aluminum stabilizer is shown in Fig. 8, compared with A5083 for the support cylinder. The strength

TABLE IV
CHARACTERISTICS OF Al-STABILIZED SUPERCONDUCTOR

	Design	Measured
Cross sections	30 mmx 4.25 mm	30 mmx4.25 mm
Area ratio (NbTi/Cu/Al)	1/0.9/15.6	1/0.8/13.7-1/0.9/14.0
Superconducting strands:		
Strand diameter	1.22 mm	1.25-1.26
Filament diameter	20 μm	21 μm
Jc in NbTi @ 5 T, 4.2 K	> 2,750 A/mm ²	>2,800 A/mm ²
Superconducting cable:		
Cross section		
Number of strands	12	12
Ic @ 5T, 4.2K	>20,300 A	22,820 A
@ 2.7 T, 7.2 K	>7,600 A	7,750 A
Al-stabilizer strength @ RRR = 600:		
Yield strength* @ 4.2 K	>85 MPa	110 MPa
Tensile strength* @ 4.2 K		294 MPa
Overall (Al+SC) strength:		
Yield strength.* @ 4.2 K		146 Mpa
Shear strength b/w Al-Cu* @4.2K	>30 MPa	80 MPa

* Strength measured after heat-treatment of 130 deg C for 15 hr.

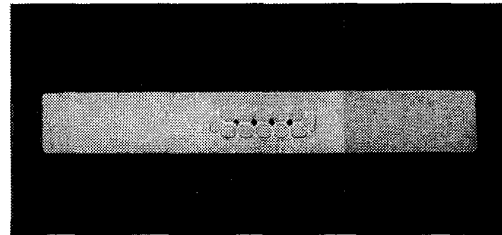

Fig. 6. Aluminum stabilized superconductor cross section.

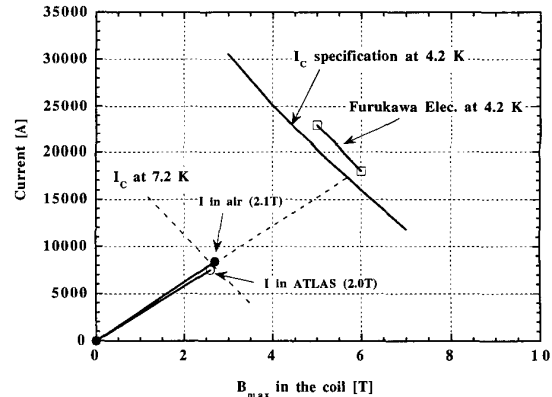

Fig. 7. Critical current characteristics of the superconductor and the solenoid load line characteristics.

TABLE V
MECHANICAL STRENGTH OF AL-STABILIZER AND CONDUCTOR. AFTER CURING AT 130 °C FOR 15 HOURS.

	Temp.	0.2% Y. S.	T. S.
Aluminum Stabilizer:	300 K	81 MPa	86 MPa
	77	99	157
	4.2 K	110	294
Over-all (AL+NbTi/Cu)	300 K	128	184
	77 K	131	---
	4.2 K	147	---

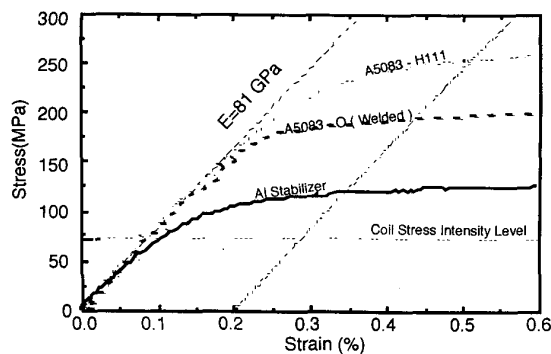

Fig. 8. Stress-strain curve of Al stabilizer compared with A-5083.

was obtained in the measurement after a heat treatment at 130 °C for 15 hours to take into account of coil curing after the coil winding. Fig. 9 shows the yield strength of aluminum stabilizer at 4.2 K as a function of RRR. Basically the additives contribute to improve the strength with less contribution to increasing the electrical resistance. The mechanical cold work has a major effect to improve the mechanical strength. The micro-alloying may contribute to keep its mechanical stability during and after the coil curing process at 130 °C. Further details are still to be investigated.

B. Solenoid Coil

The solenoid coil is wound inside the coil support cylinder, which has been fabricated by Oxford Instruments, UK, in cooperation with Romabau, Switzerland. Figure 10 shows the picture of the support cylinder completed. Cooling tubes are welded on the outer surface, and two end-rings are attached by using bolts to interface triangle-shape coil supports from the vacuum vessel. Polyimide film, Upilex, has been chosen for electrical insulation. The film is preprocessed with glass-cloth and epoxy-resin (GUG) for the best electrical and bonding performance [12], [13]. The single layer coil is to be wound directly inside the coil support cylinder with turn-to-turn insulation by using a laminated tape of Upilex and epoxy-resin. Inside the coil, the pure-Al strip quench propagators will be glued in axial direction after ground plane

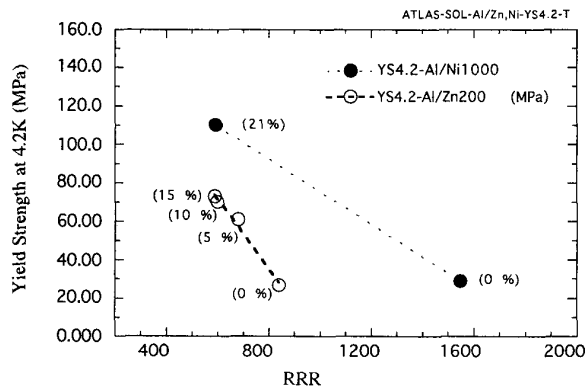

Fig. 9. Yield strength v.s. RRR of high-strength Al stabilizer.

insulation work inside. The coil winding is being prepared by Toshiba, Japan. The coil is to be supported by 12 triangle-shaped coil supports made of GFRP at each axial end. The supports have been fabricated by Arisawa Mfg. Company. As a test result, each support can sustain more than 50kN with keeping a safety factor of > 4 against electromagnetic de-centering force [14].

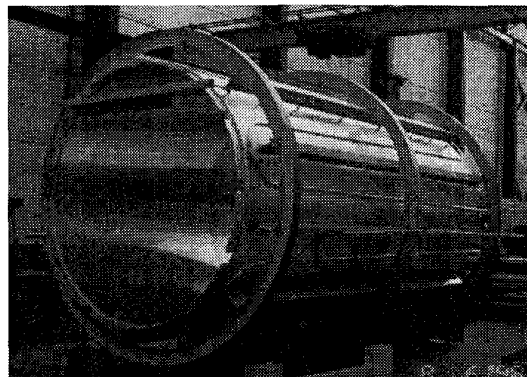

Fig. 10. Picture of the coil support cylinder

IV. SUMMARY

The ATLAS central solenoid magnet was designed to provide a magnetic field of 2T in a warm volume of 2.3 m in diameter and 6.3 m in length with an E/M ratio of 7 kJ/kg. A coil transparency of 0.66 radiation length is expected in the design featured with high-strength aluminum stabilized superconductor at a yield strength of > 100 MPa at 4.2 K with RRR = 600. The coil fabrication is in progress and is to be completed in 2000.

ACKNOWLEDGMENT

The authors would like to thank the ATLAS collaboration for continuous support and encouragement to proceed this work. They would like to thank Romabau AG, Switzerland for the cooperative work with Oxford Instruments Co. Ltd. The KEK-team would like to thank Dr. J. Sondericker and his team at BNL for their cooperative work in interfaces with LAR calorimeter. Finally, the authors would thank KEK and CERN for continuous support and encouragement in this work.

REFERENCES

- [1] ATLAS Technical proposal, CERN/LHCC/94-43, LHCC/P2 (1994).
- [2] H. ten Kate et al, "ATLAS magnet system, Technical Design Report" CERN/LHCC/97-20, ATLAS TDR 9, 1997.
- [3] A. Yamamoto et al, ATLAS Central Solenoid Technical Design Report, CERN/LHCC/97-2, ATLAS-TDR-9, 1997.
- [4] Y. Makida et al, IEEE Trans. Appl. Supercond., No. 7 1997, p. 638.
- [5] K. Tanaka et al, Proc. ICEC-16, Kita-kyushu, Japan, 1996, p.119-122.
- [6] A. Yamamoto et al, IEEE Trans. Appl. Super. Vol. 5, 1996, P.849.
- [7] Y. Makida et al., Adv. Cryog. Eng. 37, 1991, p. 401-407.
- [8] A. Takahashi et al, developed by Sumitomo-Chemical Co. Ltd.
- [9] T. Haruyama et al., Cryogenics 36, 1996, p. 465-469.
- [10] I. Inoue et al, Supercollider, No. 4, 1992, p.943.
- [11] K. Wada, Furukawa Electric. Co., personal communication, 1998.
- [12] F.R. Fickett, Cryogenics, 1971, p. 349-367.
- [13] T. Ueki et al, to be published in Adv. in Cryog. Eng., Vol. 44.
- [14] E. Evans et al, to be published in Adv. in Cryog. Eng., Vol. 44.
- [14] H. Yamaoka, et al, Proc. MT15, Beijing, 1997, p. 204-207.