



# Design and implementation of an intelligent low-cost IoT solution for energy monitoring of photovoltaic stations

Youssef Cheddadi<sup>1</sup> · Hafsa Cheddadi<sup>1</sup> · Fatima Cheddadi<sup>1</sup> · Fatima Errahimi<sup>1</sup> · Najia Es-sbai<sup>1</sup>

Received: 15 October 2019 / Accepted: 30 May 2020 / Published online: 4 June 2020  
© Springer Nature Switzerland AG 2020

## Abstract

Smart grids exploit the capability of information and communication technologies especially internet of things, to improve the sustainability, quality and the performance of energy production and demand previsions, whereas reducing resource consumption and increasing renewable energies integration. This paper aims to present a cost-effective and open source internet of things solution that could collect in intelligent manner and monitor in real-time the produced power and environmental conditions of solar stations. The solution is designed as a laboratory prototype that could be extended to monitor large scale photovoltaic stations using small adjustments. The system also provides an alert to a remote user, when there is a deviation of solar power generation quality parameters from the predefined set of standard values.

**Keywords** Photovoltaic station · IoT · Cloud · Sensor network · Real-time monitoring · ESP32 microcontroller · Data-acquisition system

## 1 Introduction

Energy demands are steadily increasing, leading to excessive consumption of fossil energy resources. Indeed, to meet the energy needs of today's society, it is necessary to find more sustainable, effective and clean solutions for the environment. Among renewable energies sources, solar energy is considered the most fascinating source that could balance this gap between the consumption and the production, thanks to the remarkable decreasing in its cost and the advancement in this technology [1]. With modern monitoring and control systems, this technology become a reliable sources of energy [2].

Smart grids exploit the capability of information and communication technologies (ICT) to improve the sustainability, quality performance and balance of energy production and demand previsions, whereas reducing resources consumption. ICT also help smart grid to integrate renewable energies.

Internet of things (IoT) is playing a crucial role in the daily life of humans by enabling the connectivity of many physical devices through internet where the devices are intelligently linked together enabling new kinds of communication between things and people, and between things themselves to exchange the data for monitoring and controlling the devices from anywhere around the globe using the internet connection [3]. Additionally, The communication between machines or different devices is possible without human intervention using the IoT applications [4].

The idea behind IoT principle is to connect the sensors and devices of a special system on a common network through wired or wireless nodes. In general, IoT based wireless systems are widely chosen in order to avoid associated risks with wired systems. While keeping in mind the needs of near future, where every device will be smart, automated and connected via internet. For more details, authors in [3] have investigated some technical details

✉ Youssef Cheddadi, [youssef.cheddadi@usmba.ac.ma](mailto:youssef.cheddadi@usmba.ac.ma) | <sup>1</sup>SMBA University, Fez, Morocco.



that refer to the IoT enabling technologies, protocols, and applications. They have explained the link between the IoT technology and the other emerging technologies including cloud services, big data analytics and fog computing.

The purpose of PV monitoring systems is to offer continuously a clear information about various parameters, namely the energy potential, extracted energy, fault detection, historical analysis of the plant, and associated energy loss. Furthermore, the monitored data can be used for preventive maintenance, early detection of warning and evaluating the weather variations ...etc. [1, 5]. Many classifications of PV monitoring systems based on the internet technology, data acquisition systems used and monitoring system methods have overviewed in detail in [2].

The remote supervising technology could be used in numerous applications related to solar field, namely: Solar plants, solar stations for charging electric vehicles [6], micro grids [7] and solar street lights and so on. Also in many other vital applications such as the monitoring of the water quality [8], and the monitoring and control of solar thermal station with solar collector [9].

Since we are interested in photovoltaic part of the solar energy, we have studied the state of the art of wireless remote monitoring related to PV applications during the last decade. Starting by a comprehensive review on monitoring systems for photovoltaic plants; the communication and storage in data acquisition systems, challenges and opportunities in existing and futuristic systems have discussed in [1]. PV performance metrics was monitored and processed ubiquitously using cloud data logging with a LabVIEW based monitoring system was presented in many researches [10–13].

Researchers in [14] have elaborated a low cost IoT application based on embedded solar PV monitoring system using a GPRS module and a microcontroller to send the data measured. However, authors in [15] have reported a real-time monitoring of solar home systems based on Arduino microcontroller with 3G Connectivity. Whereas, a remote monitoring for solar photovoltaic systems in rural application using GSM voice channel have presented in [16].

An IoT-based experimental prototype for monitoring of photovoltaic arrays has been developed in [17]. Furthermore, a cost effective IoT technique in order to remotely supervise the maximum power point (MPP) of a photovoltaic system has described in [18].

A health monitoring system of a solar farm has been developed in [4], with a validation concept using eight solar panels to monitor the string voltage, string current, temperature and humidity. The system is controlled by CC3200 microcontroller with ARM Cortex-M4 architecture.

Since PV panels are sensitive to environmental parameters, specifically irradiance and temperature, the electric

data, weather information are considered essential for analysing PV station state. This is why supervising the performance of every PV systems is very important [13, 19].

From the studied state of the art, we notice many IoT solutions for monitoring PV systems based on low cost processing boards such as raspberry, Arduino boards, but the common point between these solutions is the utilization of expensive pyranometers in the entry of the photovoltaic system to measure irradiance. In this paper, a low-cost lux meter is utilized instead in intelligent manner. The proposed IoT solution embraces the data acquisition, processing functions, data analysis and visualization of the PV station performances. Moreover, an alert system based on the monitored parameters is included. All these features with an effective cost of the instruments and monitoring system. The concept of the proposed solution is based on open source and low-cost technology in sensing, data acquisition, processing, and transmission system using ESP32 board. A data-driven estimation of irradiance was extracted from a pyranometer and a lux meter in order to validate the global luminous efficacy relationship and then lower the cost of instruments used by replacing an expensive pyranometer by a low cost illuminance sensor.

The rest of the paper is organized as follow: Sect. 2 presents the architecture of the proposed IoT based photovoltaic data monitoring. Section 3 presents the hardware and software of the designed system. Results are described in Section 4 and a discussion is investigated in Sect. 5.

## 2 Proposed system design

Since the data needs to be collected, processed, stored and analyzed in an IoT setup, a low cost data pipeline for monitoring the electrical and environmental parameters in a photovoltaic station is designed in this work.

In the proposed monitoring system, the ESP32 DEVKIT V1 board acts as the microcontroller that acquires and processes the incoming data from various sensors, then it transmits the processed data to the cloud and servers via built-in Wi-Fi. Data communication occurs in two steps: The first step is the communication between sensors, and the controller via inter-integrated circuit protocol (I2C), then the second step is the communication between controller and the cloud service application via Wi-fi protocol.

The data collected by the various sensors is stored in the cloud (web server) or locally. The exchange is based on client and server requests. A client launches an HTTP request, and the server returns an answer. This protocol defines the communication between the different parts of the web. The bloc diagram of the proposed IoT solution that used to monitor photovoltaic plants, is illustrated in Fig. 1 bellow:

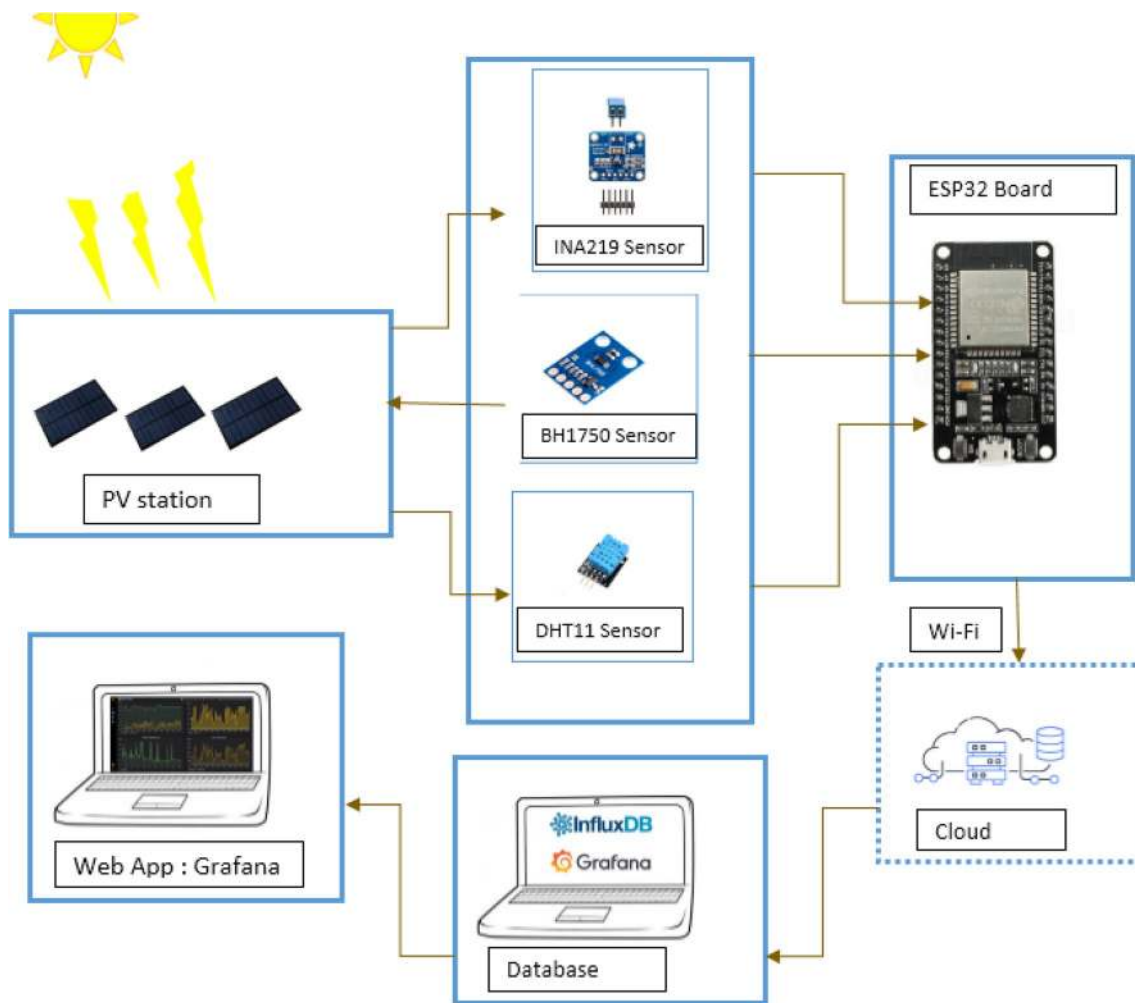

Fig. 1 Block diagram of the overall system

### 3 Hardware and software design

#### 3.1 Hardware design

The experimental setup of the system hardware, drawn with fritzing software is illustrated in Fig. 2.

The developed experimental prototype consists mainly of the PV system including the battery, sensors and the dual core ESP32 controller (Figs. 3, 4, 5):

##### 3.1.1 Photovoltaic System

The photovoltaic system in this experimental setup consists of three PV panels, a DC–DC Buck converter and a Lithium ion battery as a load.

**3.1.1.1 PV panel** The PV panels consist of a set of parallel and series PV cells that convert the sun light into DC electrical energy. Three small polycrystalline PV panels with a

dimension of 115 mm×85 mm are capable to generate 1.6 W of power and 12 V of voltage for each one, are used in this work.

**3.1.1.2 Regulator TP4056** To harvest the maximum of generated PV energy and reduce the power losses, a stage of adaptation is necessary. For this reason, a dc–dc converter is placed between the PV generator and the load to adjust the maximum power point MPP using an MPPT control [20]. Since a lithium ion battery is used as a load, an associated commercial regulator TP4056 that incorporates protection features is also used, but it is important to note that this regulator does not incorporate the MPPT algorithm in its features.

**3.1.1.3 DC load** The Lithium-ion battery used in mobile phone applications, is employed as a load in this monitoring prototype. This battery of 3.7 V nominal voltage is protected by the regulator that controls the charging current

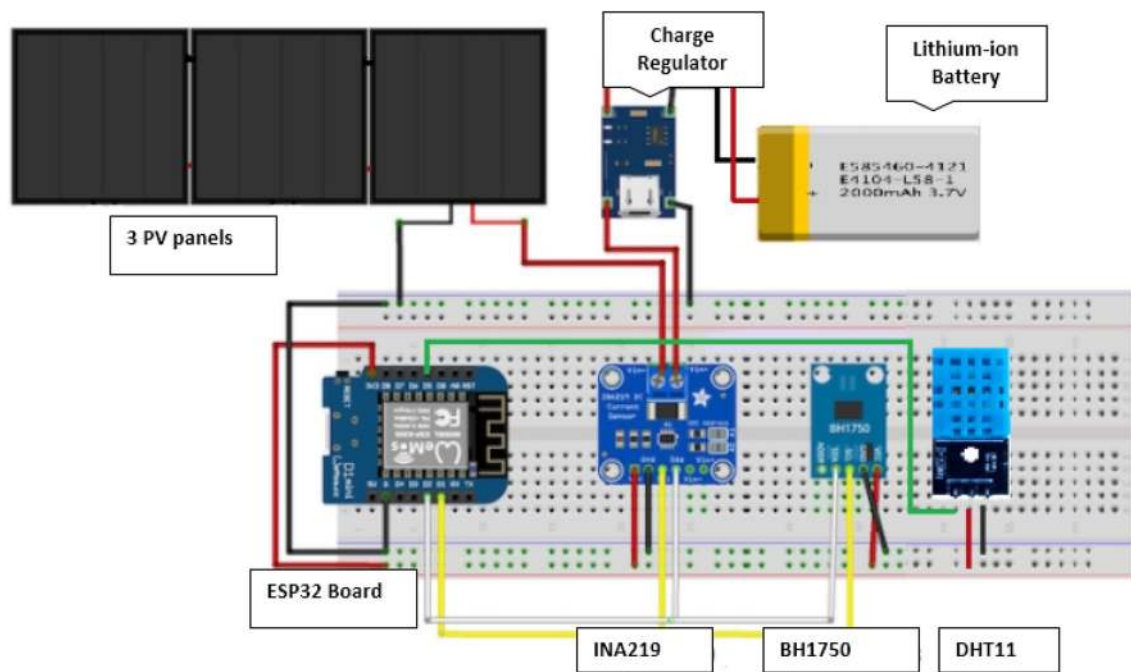

Fig. 2 The experimental setup of the system



Fig. 3 The PV panel used in the prototype

(1A maximum). Besides, It is equipped with an overload protection circuit (charging stops at 4.3 V), an excessive discharge protection to avoid destruction of the battery, and an overcurrent detection at the battery output level to avoid the battery damage in case of a short circuit.

### 3.1.2 Measurement Sensors

The measurement sensors network in the presented application involves three main sensors that sense four physical signals: Current, Voltage, irradiation and temperature.

**3.1.2.1 Current/voltage sensor** This is a smart sensor that senses, makes also filtering and analog to digital conversion. INA219 sensor is a current and power sensor that



Fig. 4 The current/voltage DC sensor INA219



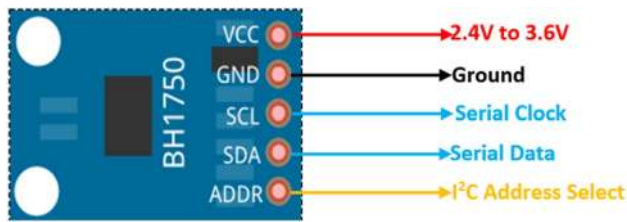

**Fig. 5** The Luminosity sensor BH1750

**Table 1** Features of the sensor INA219

Parameter	Value
Power supply	3 to 5 V
Current detection resistor	0.1 Ω 1% 2 W
Measuring range: voltage	Up to 26 V
Measuring range: current	Up to 3.2 A
Resolution	0.8 mA
I2C addresses (on 7 bits):	0×40, 0×41, 0×44, 0×45

gives the total power consumed by shunt load and gives respective reading in digital form. It can handle high side current measuring up to +26 V of voltage and up to 3.2 A of current, even though it is powered with 3.3 or 5 V. It is equipped with an I2C bus, which makes it easy to retrieve measurements using a microcontroller. The essential characteristics of this sensor are listed in Table 1.

**3.1.2.2 Illumination sensor** It is possible to check the rate of sunshine using the BH1750 according to different parameters: time of day, inclination, location, orientation, season... BH1750 is a digital ambient light sensor integrated circuit, which considered as a lux meter that gives a wide range of measurement and high resolution (1–65535 lx). The BH1750 module communicates via the I2C bus with the ESP32 controller to transmit the measured data.

A Lux meter (in this work BH1750 sensor) measures the sunlight intensity in (lux) and the direct conversion of its value to irradiance value in ( $W/m^2$ ) is not possible since the nature of the measured parameter is different. But one of the important claims of this paper is using the fusion sensor principle to lower the cost of the instruments used to collect irradiation. Instead of using an expensive pyranometer, a software approximation is used based on data collected from both the BH1750 sensor and a calibrated pyranometer LP02 of the laboratory to estimate a relationship between the two measurements.

In this paper, the laboratory pyranometer is exploited to find the global luminous efficacy relationship. The

global luminous efficacy is defined as the ratio of global illuminance and global irradiance [21, 22]. This relationship that is found a linear function, was deduced based on numerous physical measurements with both instruments approximately in the same time, then it was implemented in the software to convert the reading of the BH1750 sensor to irradiance.

The solar radiation sensor used to measure irradiance then extract this relationship is the pyranometer LP02, which complies with class C specifications of the IEC 61724-1 standard. This scientific instrument costs more than \$600, and owing to this low-cost method, the irradiance measurement becomes possible with acceptable accuracy using an illuminance sensor that costs less than 10 \$.

**3.1.2.3 Temperature sensor** The sensor DHT11 is a low cost temperature and humidity sensor, which is widely used in embedded projects. Its temperature range is from 0 to 50 degrees Celsius with  $\pm 2$  degrees accuracy. DHT11 has good quality, fast response time and provides high stability. For temperature measurement, it has a thermistor embedded in it, which measure temperature. To ensure the accuracy of measurements, this sensor was also calibrated using another trustworthy thermometer.

### 3.1.3 ESP32 based controller

ESP32 is a low-cost, low-power consumption system-on-chip (SOC) microcontroller, with integrated Wi-Fi and dual-mode Bluetooth and low power support, all in a single chip. This board is selected because it reduces the cost of the monitoring system and thanks to its high processing performances. ESP32 board is based on Tensilica 32-bit dual-core CPU Xtensa, LX6 Microcontroller [23]. One of its major advantages that it can be coded using many open-source platforms and languages. In this study, we developed codes using Arduino IDE and uploaded directly to the board.

Figure 6 shows the ESP32 DEVKIT V1 board used in this IoT project, and the Table 2 summarizes some of its technical specifications.

ESP32 takes the advantages of Linux-based IOT boards such as Raspberry Pi, Beaglebone...etc. that support operating systems (OS), but they need external ADC devices to acquire analog measurements, besides their high cost and energy consumption compared to the ESP32. Furthermore, this latter offers the advantages of the low-cost boards such as Arduino boards that need, in their turn, additional components and shields to be connected to the internet. Indeed, ESP32 supports real-time operating systems (RTOS) like freeRTOS, to manage optimally all the tasks required, it integrates 16 ADC channels of 10 bits to



**Fig. 6** The ESP32 DEVKIT V1 board used as controller

**Table 2** Summary of features of ESP32 board

Feature	Value
Operating voltage	3.3 V
Input voltage	7–12 V
Digital I/O pins (GPIO)	25
Analog input pins (ADC)	6
Analog outputs pins (DAC)	2
UART	3
SPI	2
I2C	3
Flash memory	4 MB
SRAM	520 KB
Clock speed	240 MHz
Wi-Fi	IEEE 802.11 b/g/n/ e/i

acquire analog information and a built-in Wifi to be connected and many other features. Moreover, ESP32 chip offers a high flexibility in software development; three easy to understand programming and open source environments for both researchers, engineers and PV owners. These platforms are Arduino IDE, the constructor Espressif

environment and Micro-Python the emergent language in embedded software development (Table 3).

All the described characteristics of the IoT board and the sensors used in this monitoring system are presented in a low cost as demonstrated in table below, with a total cost of 7.71 \$. The price are extracted from ([www.aliexpress.com](http://www.aliexpress.com)).

### 3.2 Software design

#### 3.2.1 Grafana & influx DB

Grafana is an open source platform for data monitoring, analysis and visualization, delivered with a web server that allows access from anywhere. It is free software under Apache 2.02 license that allows the user to create graphs and dashboards over time. This independent cross-platform is also an essential tool for creating alerts. Grafana has a full HTTP API, which makes it very efficient. It allows us to create dashboards and graphs from several sources including time series databases such as Graphite, Influx DB, as well as MySQL [24].

Data transmitted from the ESP32 controller are stored in the cloud; in our case installed locally in “InfluxDB” database. “Grafana” offers a platform for researchers and engineers to acquire, analyze and visualize the useful information graphically. In addition, Grafana could be linked to various local databases and web servers, and InfluxDB amongst them. Furthermore, it includes a real-time dashboard and could share the data through public links. Data stored in the cloud can be used for a further detailed analysis. Moreover, the platform is programmed to send e-mail notifications whenever the monitored parameters overpass the threshold limit. The thresholds are configured and predefined before. Table 4 presents a summary of useful features of Grafana cloud platform.

The process to connect the system to the database (InfluxDB) and Grafana cloud tracks the following steps:

- Connect to the access point using ssid and password through mobile phone, tablet or personal computer.
- Configure the database with Grafana.

**Table 3** The cost of the IoT monitoring solution

Reference	Price (\$)
Doit ESP32 Dev Kit V1	4.61
INA 219B	1.55
DHT11	0.83
BH1750	0.72
Total	7.71

**Table 4** Summary of useful features of Grafana Labs platform

Features	Description	Options available
Dashboard	Create real-time dashboards to analyze data or control devices	Panels Graph(X-axis: time, series, histogram), Singlstat, Table, Heatmap, Alerts list, Dashboard list, Plugin list Metric Mean Maximum Minimum Count Sum median First/Last value, Bottom/top value, percentile Indicator Gauge, Bar gauge
Events	Create alerts based on your sensor data Captures an image and include it in the notification	Email, Telegram, Webhook, OpsGenie, Pushover, discord, LINE, Microsoft Teams, Google hangouts chat, Threema gateway, PagerDuty, DingDing, Sensu, Slack, victorOps, prometheus Alermanager, HibChat, kafka REST Proxy

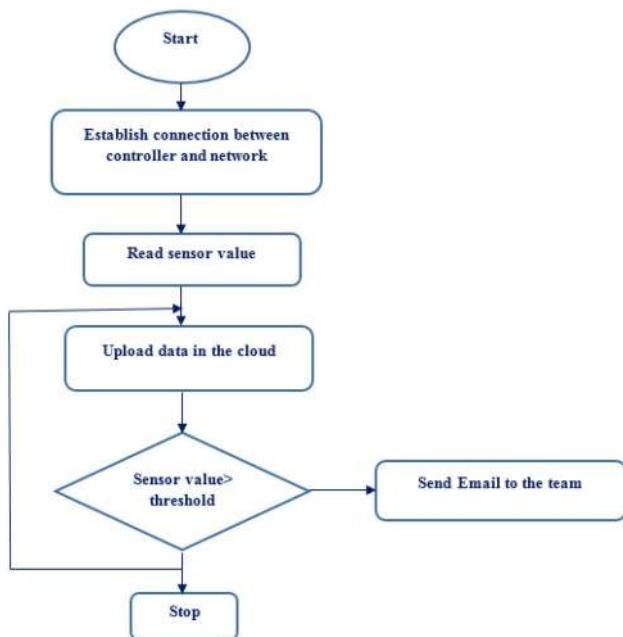

**Fig. 7** The Flow chart for the proposed IoT solution

- The controller is then connected to the access point using Wi-Fi.
- Data from the controller is loaded into the database.
- Data is graphically displayed on the cloud platform.

**3.2.2 Monitoring algorithm**

The algorithm of the proposed internet of things solution that monitors solar farms is illustrated in the flow chart of Fig. 7.



**Fig. 8** A caption of Irradiance and Temperature monitored

**4 Results**

Five parameters namely Power, current, voltage, temperature and irradiance level are measured using the experimental setup. This latter is connected wirelessly to the InfluxDB database and visualized via Grafana platform.

Figure 8 displays the dashboard with different widgets to present and visualize the results of data collected in the cloud. This figure shows the environmental measurements namely the temperature and irradiance with the accurate time and date of sensing the data.

Figure 9 shows the captured electrical measurements in real time visualized in Grafana dashboards namely the current, voltage and power with the accurate time and date of collecting the data. As it is mentioned, the system does not integrate any MPPT algorithm to maximize the generated power from the panel. However, it demonstrates the real time monitoring of station measurements.

A threshold in red line is shown on the PV power histogram (in bottom). This event is determined to verify reliability of this IoT monitoring system to alert the user



Fig. 9 A caption of the PV current, voltage and power monitored



Fig. 10 PV panels under shading effect

or stakeholder whenever the monitored power is lower than the threshold (a fault occurrence). For this end, the verification of this test case is proceeded by exposing the PV panels to the shade for a precise time as it is shown Fig. 10, then the results of both the irradiance and the power measurements are inspected.

Figure 11 shows the drop in irradiation values due to the exposition of the PV panels to the shading during a



Fig. 11 The monitored irradiance in shading effect

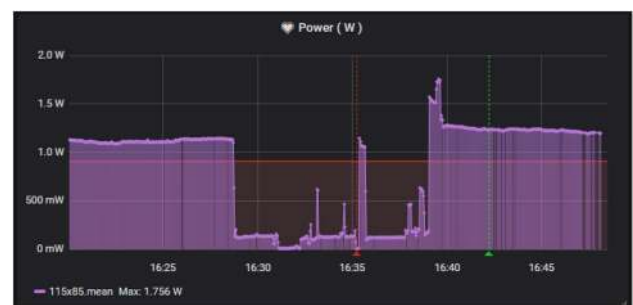

Fig. 12 The monitored PV power under shading effect

period of time. This huge drop in irradiation has led to a descent in the power produced under the threshold of the predefined standards as it is displayed in Fig. 12.



Figure 13 shows the alert notification displayed in the dashboard and send to the mail address due to decreased value of power (upper side). Before this time, the produced power was within the standard values i.e. higher than the predefined threshold (bottom side).

### 5 Discussion

In this paper, a cost effective IoT system to gather and monitor in real-time both environmental and electric data of a PV solar station is proposed. The low-cost of this solution comes from the accurate choice of the controller and the instruments used. Two low-cost sensors are used to measure the enviremental variation: the DHT11 was used for temperature after its calibration with a thermometer.

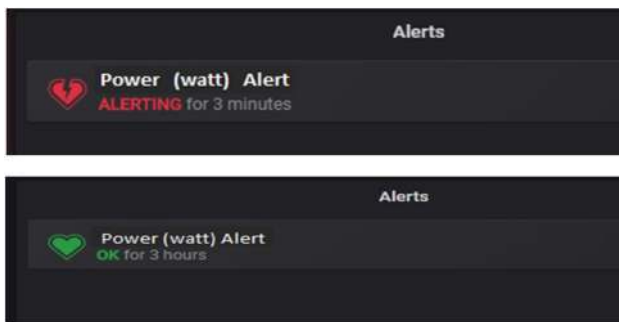

Fig. 13 A caption of alerts in event occurrence

Then, the light sensor BH1170 which is a lux meter, was used in innovative way to measure solar irradiance after deducing an accurate data-driven approximation between the lux meter and a calibrated pyranometer. These solutions lead to decrease the total cost of the system. For the electrical parameters, the power/current sensor INA219 was employed to measure the current, voltage and the power generated by PV array.

Owing to its high computation performances, simple programing and low-cost, the ESP32 controller is chosen to acquire, process and transmit in real time the gathered data. Besides its high calculation capabilities, this controller incorporates a built-in WiFi technology, which means that our application will not require additionnal ethernet or wifi shields to ensure its connection to the internet and the transmission of data to the cloud.

The table thereafter summarizes the cost comparison of controllers used in IoT solutions of PV monitoring in litterature.

As shown in Table 5, the micro-computers such as Raspberry Pi and Beaglebone black provide a very high computation performances, but on the other hand, they require external ADC devices to acquire analog measurements, then they are more expensive and consume an important amount of energy to operate compared to the ESP32 board. Moreover, the ESP32 controller offers the advantages of the arduino boards in easy to use programming tools, analog reading capabilities and their low-cost, then it completes their weaknesses in IoT application in terms of high computation and connectivity.

Table 5 Comparison of controllers used in IOT solution

Paper	Characterestics	Controller used	Control-ler price (\$)
[25]	High computation Need external ADC Wifi built-in High power consumption	Raspberry Pi	49.88
[2]	Low computation Integrated ADCs Need Ethernet or GSM shield Low power consumption	Arduino Mega2560	5.50
[26]	Low computation Integrate ADC No wireless connection (External RF) Low power consumption	PIC 16F877	3.20
[27]	Very High computation Need external ADC No wireless connection (add GSM module) High power consumption	BeagleBone black	54.40
The proposed	High computation Integrated ADCs Wifi built-in Low power consumption	ESP32	4.61

In addition to the low cost of the controller used in this work, Grafana is an open-source platform with user-friendly pattern to visualize graphs and dashboards in interactive way. Compared to many works that monitor PV systems, have used LABVIEW [10, 12, 28], which is an expensive commercial software, with its hardware instruments. Thus, the software of this solution may be also considered low-cost for energy monitoring of a large PV systems.

The proposed system is able to update the measured data every second in grafana dashboards, but it worth to mention that a delay take places when sending alerts by mails.

On the other side, in a large scale solar PV farms, the required electrical sensors will be much expensive and powerful than those used in this prototype since the range of the current/voltage requirements will be higher. But, there are many powerful current and voltage sensors existing in the market which are known for their accuracy and low demand for energy such as the Hall Effect Current Transducer (HCT0036) that can sense up to 500 A...etc.

To summarize, the proposed IoT application is able to continuously supervise and maintain the PV plant in a safe state and high working performances, monitor the weather conditions of the station and alert the user to control the effect of the failure when it occurs, all these features in an effective cost with a capability to perform well in monitoring large scale solar farms, with small changes in the used electrical sensors.

## 6 Conclusion

The paper investigates studies on the tools and techniques used in existing solar plant monitoring systems. Furthermore, a smart low cost IoT solution for monitoring the electrical and environmental parameters of photovoltaic system is proposed. An implementation of a laboratory prototype is established to demonstrate the performance of the developed solution. Several smart sensors, a cutting-edge controller and an algorithm for solar array monitoring are described in this work to provide real time data to stakeholders. Besides, a low-cost indirect measurement method is proposed to decrease the cost of the measurement instruments. The experimental test bench is enhanced by integrating alerts for anomaly detections in PV stations. Finally, the cost effectiveness of the proposed solution has found essentially in the low-cost edge sensing methods, open source software and processing technologies used. The study is validated by an economical study of the proposed acquisition and monitoring system.

**Acknowledgements** The authors would like to thank the Design-Tronik sarl, Morocco, for providing the materials and the computer facilities used to develop some parts of the work presented in the paper.

## Compliance with ethical standards

**Conflict of interest** The authors declare that they have no conflict of interest.

## References

1. Madeti SR, Singh SN (2017) Monitoring system for photovoltaic plants: a review. *Renew Sustain Energy Rev* 67:1180–1207. <https://doi.org/10.1016/j.rser.2016.09.088>
2. Rahman MM, Selvaraj J, Rahim NA, Hasanuzzaman M (2018) Global modern monitoring systems for PV based power generation: a review. *Renew Sustain Energy Rev* 82:4142–4158. <https://doi.org/10.1016/j.rser.2017.10.111>
3. Al-Fuqaha A, Guizani M, Mohammadi M, Aledhari M, Ayyash M (2015) Internet of things: a survey on enabling technologies, protocols, and applications. *IEEE Commun Surv Tutor* 17(4):2347–2376. <https://doi.org/10.1109/comst.2015.2444095>
4. Badave PM, Karthikeyan B, Badave SM, Mahajan SB, Sanjeevikummar P, Gill GS (2018) Health monitoring system of solar photovoltaic panel: an internet of things application. In: *Advances in smart grid and renewable energy*, pp 347–355
5. Adhya S, Saha D, Das A, Jana J, Saha H (2016) An IoT based smart solar photovoltaic remote monitoring and control unit. In: *2016 2nd International conference on control, instrumentation, energy communication (CIEC)*, pp 432–436. <https://doi.org/10.1109/ciec.2016.7513793>
6. Youssef C, Fatima E, Najia E, Chakib A (2018) A technological review on electric vehicle DC charging stations using photovoltaic sources. *IOP Conf Ser Mater Sci Eng* 353(1):012014. <https://doi.org/10.1088/1757-899x/353/1/012014>
7. Cheddadi Y, Gaga A, Errahimi F, Sbai NE (2015) Design of an energy management system for an autonomous hybrid micro-grid based on Labview IDE. In: *Renewable and sustainable energy conference (IRSEC), 2015 3rd international*, pp 1–6
8. Geetha S, Gouthami S (2017) Internet of things enabled real time water quality monitoring system. *Smart Water* 2(1):1. <https://doi.org/10.1186/s40713-017-0005-y>
9. Saravia MWD, Salvador R, Palencia CM, Zepeda AEP (2017) Monitoring system for solar thermal station with IoT and M2M. In: *2017 IEEE 37th Central America and Panama Convention (CONCAPAN XXXVII)*, pp 1–6. <https://doi.org/10.1109/concapan.2017.8278533>
10. Touati F, Al-Hitmi MA, Chowdhury NA, Hamad JA, San Pedro Gonzales AJR (2016) Investigation of solar PV performance under Doha weather using a customized measurement and monitoring system. *Renew Energy* 89:564–577. <https://doi.org/10.1016/j.renene.2015.12.046>
11. Forero N, Hernández J, Gordillo G (2006) Development of a monitoring system for a PV solar plant. *Energy Convers Manag* 47(15):2329–2336. <https://doi.org/10.1016/j.enconman.2005.11.012>
12. Rezk H, Tyukhov I, Al-Dhaifallah M, Tikhonov A (2017) Performance of data acquisition system for monitoring PV system parameters. *Measurement* 104:204–211. <https://doi.org/10.1016/j.measurement.2017.02.050>

13. Chouder A, Silvestre S, Taghezouit B, Karatepe E (2013) Monitoring, modelling and simulation of PV systems using LabVIEW. *Sol Energy* 91:337–349
14. Kekre A, Gawre SK (2017) Solar photovoltaic remote monitoring system using IOT. In: 2017 International conference on recent innovations in signal processing and embedded systems (RISE), pp 619–623. doi:10.1109/RISE.2017.8378227
15. López-Vargas A, Fuentes M, Vivar M (2019) IoT application for real-time monitoring of solar home systems based on Arduino™ with 3G connectivity. *IEEE Sens J* 19(2):679–691. <https://doi.org/10.1109/JSEN.2018.2876635>
16. Tejwani R, Kumar G, Solanki C (2014) Remote monitoring for solar photovoltaic systems in rural application using GSM voice channel. *Energy Procedia* 57:1526–1535
17. Hamied A, Mellit A, Zoulid M, Birouk R (2018) IoT-based experimental prototype for monitoring of photovoltaic arrays. In: 2018 International conference on applied smart systems (ICASS), pp 1–5. doi: 10.1109/ICASS.2018.8652014
18. Rouibah N, Barazane L, Mellit A, Hajji B, Rabhi A (2019) A low-cost monitoring system for maximum power point of a photovoltaic system using IoT technique. In: 2019 International conference on wireless technologies, embedded and intelligent systems (WITS), pp 1–5. <https://doi.org/10.1109/wits.2019.8723724>
19. Han J, Lee I, Kim S-H (2015) User-friendly monitoring system for residential PV system based on low-cost power line communication. *IEEE Trans Consum Electron* 61(2):175–180. <https://doi.org/10.1109/TCE.2015.7150571>
20. Cheddadi Y, Cheddadi F, Errahimi F, Es-Sbai N (2017) Extremum seeking control-based global maximum power point tracking algorithm for PV array under partial shading conditions. In: Wireless technologies, embedded and intelligent systems (WITS), 2017 international conference on, pp 1–6
21. Perez R, Webster K, Seals R, Stewart R, Barron J (1987) Variations of the luminous efficacy of global and diffuse radiation and zenith luminance with weather conditions—description of a potential method to generate key daylight availability data from existing solar radiation data bases. *Sol Energy* 38(1):33–44. [https://doi.org/10.1016/0038-092X\(87\)90068-5](https://doi.org/10.1016/0038-092X(87)90068-5)
22. Wright J, Perez R, Michalsky JJ (1989) Luminous efficacy of direct irradiance: variations with insolation and moisture conditions. *Sol Energy* 42(5):387–394
23. ESP32 Overview | Espressif Systems. [Online]. Available: <https://www.espressif.com/en/products/hardware/esp32/overview>. Accessed 19 Jan 2019
24. Grafana Features, *Grafana Labs*. [Online]. Available: <https://grafana.com/grafana/#alert>. Accessed 09 Oct 2019
25. Pereira RI, Dupont IM, Carvalho PC, Jucá SC (2018) IoT embedded linux system based on Raspberry Pi applied to real-time cloud monitoring of a decentralized photovoltaic plant. *Measurement* 114:286–297
26. Benganem M (2009) Measurement of meteorological data based on wireless data acquisition system monitoring. *Appl Energy* 86(12):2651–2660. <https://doi.org/10.1016/j.apenergy.2009.03.026>
27. Ngo GC, Floriza JKI, Creayla CMC, Garcia FCC, Macabebe EQB (2015) Real-time energy monitoring system for grid-tied Photovoltaic installations. In: TENCON 2015-2015 IEEE Region 10 conference, pp 1–4
28. Torres M, Muñoz FJ, Muñoz JV, Rus C (2012) Online monitoring system for stand-alone photovoltaic applications: analysis of system performance from monitored data. *J Sol Energy Eng*. <https://doi.org/10.1115/1.4005448>

**Publisher's Note** Springer Nature remains neutral with regard to jurisdictional claims in published maps and institutional affiliations.