

 Open access • Proceedings Article • DOI:10.2514/6.1978-997

Design and preliminary results of a semitranspiration cooled (Lamilloy) liner for a high-pressure high-temperature combustor — [Source link](#)

J. D. Wear, A. M. Trout, J. M. Smith, Robert E. Jones

Institutions: Glenn Research Center

Published on: 01 Jan 1978

Topics: Combustor, Air cooling and Combustion chamber

Related papers:

- [Advanced liner-cooling techniques for gas turbine combustors](#)
- [Combustor liner effusion cooling holes](#)
- [Combustor cooling method](#)
- [Numerical Study of Mist Film Cooling in Combustor at Operating Conditions](#)
- [Effusion Cooling System Optimization for Modern Lean Burn Combustor](#)

Share this paper:    

View more about this paper here: <https://typeset.io/papers/design-and-preliminary-results-of-a-semitranspiration-cooled-3gfwr0f0lp>

General Disclaimer

One or more of the Following Statements may affect this Document

- This document has been reproduced from the best copy furnished by the organizational source. It is being released in the interest of making available as much information as possible.
- This document may contain data, which exceeds the sheet parameters. It was furnished in this condition by the organizational source and is the best copy available.
- This document may contain tone-on-tone or color graphs, charts and/or pictures, which have been reproduced in black and white.
- This document is paginated as submitted by the original source.
- Portions of this document are not fully legible due to the historical nature of some of the material. However, it is the best reproduction available from the original submission.

**NASA TECHNICAL
MEMORANDUM**

NASA TM-78874

NASA TM-78874

(NASA-TM-78874) DESIGN AND PRELIMINARY
RESULTS OF A SEMITRANSPIRATION COOLED
(LAMILLOY) LINER FOR A HIGH-PRESSURE
HIGH-TEMPERATURE COMBUSTOR (NASA) 13 p HC
A02/MF A01

N78-24138

Unclas
16799

CSCI 21E G3/07

**DESIGN AND PRELIMINARY RESULTS OF A SEMITRANSPIRATION COOLED
(LAMILLOY) LINER FOR A HIGH-PRESSURE HIGH-TEMPERATURE COMBUSTOR**

by Jerrold D. Wear, Arthur M. Trout, John M. Smith, and Robert E. Jones
Lewis Research Center
Cleveland, Ohio 44135

TECHNICAL PAPER to be presented at the
Fourteenth Propulsion Conference
cosponsored by the American Institute of Aeronautics and Astronautics and the
Society of Automotive Engineers
Las Vegas, Nevada, July 25-27, 1978



DESIGN AND PRELIMINARY RESULTS OF A SEMITRANSPIRATION COOLED (LAMILLOY)*
LINER FOR A HIGH-PRESSURE HIGH-TEMPERATURE COMBUSTOR

Jerrold D. Wear, Arthur M. Trout, John M. Smith, and Robert E. Jones
National Aeronautics and Space Administration
Lewis Research Center
Cleveland, Ohio 44135

ORIGINAL PAGE IS
OF POOR QUALITY

Abstract

A Lamilloy combustor liner has been designed, fabricated and tested in a combustor at pressures up to 8 atmospheres. The liner was fabricated of a three layer Lamilloy structure and designed to replace a conventional step-louver liner. The liner will be used in a combustor that provides hot gases to a turbine cooling test facility at pressures up to 40 atmospheres. The Lamilloy liner was tested extensively at lower pressures and demonstrated lower metal temperatures than the conventional liner, while at the same time requiring about 40 percent less cooling air flow. Tests conducted at combustor exit temperatures in excess of 2200 K have not indicated any cooling or durability problems with the Lamilloy liner.

Introduction

This paper will describe the design, intended use and preliminary results obtained from combustor tests using a liner constructed of a semitranspiration cooling material (Lamilloy). The design of the liner and the application of the Lamilloy material will be discussed. The results of tests conducted at low pressure (8 atm), but high combustor inlet and exit temperatures will be presented. The future application of this liner and test program will also be covered.

The trend for gas turbine combustors is toward high exit temperatures at increasing compressor pressure ratios. The need for combustor liners to be durable under these conditions has always been a problem of paramount importance. As pressure and temperature levels have increased, the availability of excess air for increased liner film cooling has declined. In addition, the recent requirement by the Environment Protection Agency (EPA) to control engine emissions has severely affected the airflow distribution in combustors.¹ More effective liner cooling schemes are needed as the availability of air for liner cooling decreases.

Transpiration cooling of liners is a technique that has the potential to maintain low liner wall temperatures with reduced air flow rates. In the past, porous metal or wire structures have been used. These have not always exhibited the durability required due to plugging of the very small passages with dirt and the gradual oxidation of the surface metal, reducing the flow area. An alternative approach has been taken by the Detroit Diesel Allison (DDA) Division of General Motors with a material they call Lamilloy. This material consists of two or more layers of metal, bonded together. Air enters from one side through regularly spaced holes, flows through small etched passage-

ways to holes in the next layer of metal and continues this process until the air exits through regularly spaced holes on the flame side of the liner. The liner is cooled by a combination of effects; the air passing through the liner and the exit air acting as a film. Since the material surface is only partially covered by film air, this approach may be thought of as semitranspiration cooling.

The NASA Lewis Research Center is presently constructing a High Pressure Facility (HPF).² This facility will have the capability of operation at pressures up to 40 atmospheres. There will be a combustor test leg and a turbine test leg in this facility. The turbine test leg will consist of a complete single-stage turbine assembly, using a water brake to absorb the turbine power. The combustor, installed upstream of the turbine, has the requirement to produce exit temperatures up to 2500 K at a pressure of 40 atmospheres and an inlet-air temperature of 895 K. The ability of conventional step-louver designed liners to perform at these conditions is doubtful. Liner life may be quite short and liner damage may be accompanied by turbine damage. A Lamilloy liner might provide the durability required at this severe operating condition.

Consequently, such a liner was designed and fabricated by DDA for use in this facility. This paper will present the results that have been obtained during the low pressure testing of this liner.

Liner Cooling Advances

As indicated previously, continuing demands are being placed on the availability of combustor liner cooling and dilution air flows. Advances in liner cooling technology can provide some relief by being able to maintain existing liner metal temperatures with decreased cooling air flow. This is graphically represented in figure 1 which compares conventional liner cooling technology with advanced approaches typified by Lamilloy. The data shown in this figure were furnished by DDA and is based on their experience with various types of liner cooling methods. The figure relates the amount of cooling air required as a function of the cooling effectiveness, E_c . The cooling effectiveness is defined as:

$$E_c = \frac{T_{\text{flame}} - T_{\text{wall}}}{T_{\text{wall}} - T_{\text{coolant}}}$$

In figure 1, the region between the two lines, film cooling and transpiration cooling, is the region where advanced cooling technology results in reduced cooling air flow requirements.

*Lamilloy is a registered Trademark of the General Motors Corporation, 3044 West Grant Blvd., Detroit Mich., 48202.

Liner Design

The Lamilloy liner was designed to be an identical replacement for a conventional liner, designated as liner A, of the turbine rig combustor. Figure 2(a) is a cross-sectional sketch of the combustor showing the contour of liner A. The liner is of a conventional step-louver type and was designed to withstand the operating conditions shown in table I. This liner has undergone extensive testing to exit temperatures in excess of 2200 K with no apparent damage or deterioration. However, testing has been limited to pressures up to 8 atmospheres. There is concern that at higher pressures and heat fluxes, this liner might eventually crack and pieces would be thrown into the turbine. Compared to conventional aircraft engine liners, the metal of this liner is quite thick, being fabricated of 0.20 centimeter thick Hastelloy X material. The combustor consists of two concentric annuli of airblast fuel injectors. These injectors are a derivative of the original swirl-can module and their performance has been documented in a variety of applications.^{3,4} As with most combustors of this type, there are no dilution air holes in the liner. All air except that required for liner cooling passes directly through the array of fuel injectors.

All liners designed for use in this combustor were designed to the specifications shown in table I. The conditions shown in table I are quite stringent and the low availability of cooling air makes the liner design very critical. Since this combustor is to be used for turbine cooling research, it was desirable to operate over a very wide flow range. This is indicated by the variability on the flow factor which was specified as part of the design requirements.

At the highest flow factor and operating pressure, the system pressure drop was to be 10 percent. At this condition, a pressure loading of 0.243 MPa (35.24 psi) is applied to the liner.

The mechanical design of the Lamilloy liner is shown schematically in figure 2(b). This liner completely duplicates the contour of the step-louver liner. Figure 3 is a schematic representation of the principle of Lamilloy. Cooling air enters the liner through holes and passes between the metal layers through etched passage ways. This air is eventually conducted through one metal layer to the next by holes. The process is repeated until the air leaves the liner on the flame side. Cooling is achieved primarily by convection within the liner, though there may be some cooling due to the exiting air providing a film barrier to heating. The design chosen used three layers of material each 0.0508 centimeter (0.020 in.) thick. The selection of these dimensions was based on recent experience in fabricating combustor liners for a variety of applications. A large hole size was selected to allow passage of foreign material in the combustion air through the liner. Considerable material is in the combustion air supply but this is usually a very fine iron oxide powder (rouge) which should easily pass through the liner without plugging the passage. In HPF, the air is filtered prior to compression to 40 atmospheres, so no large particles should be present.

The heat transfer analysis was performed at the maximum operating condition as shown in table I.

The analysis assumed that the average temperature close to the fuel injectors was 2300 K, but the temperature further downstream was stoichiometric or 2650 K. Maximum hot spot temperatures were also assumed to be stoichiometric temperature. The combustor pressure loss and liner differential pressure were based upon calculations and data supplied from tests conducted with conventional film-cooled liners. Once the analysis had determined the required cooling flux and pressure drop distribution, the Lamilloy permeability could be determined. The permeability, expressed as discharge coefficients, for required flows is shown in figure 4. Figure 4 also shows the coefficient values of the three permeabilities selected and the liner length over which these values apply. The highest permeability was used in the transition region as this region requires the greatest cooling.

The material selection was based on the following factors:

- High temperature oxidation resistance
- Buckling resistance
- High modulus of elasticity
- High temperature strength
- Ease of fabrication/repair

Of these, high temperature strength and oxidation resistance were judged to be of greatest importance in this application. Hastelloy X, Haynes 188 and TD Nickel-Chrome materials were evaluated. Haynes 188 was selected for use as it has better high temperature strength than Hastelloy X without the difficult fabrication and welding problems of TD Nickel-Chrome.

The liners underwent considerable stress and buckling analysis. Where appropriate, finite element stress analysis was used. The buckling analysis led to the conclusion that five stiffening rings were required on the outer liner and these were added to the liner at the positions indicated by analysis. See figures 2(b) and 5(b).

The estimated life of the Lamilloy liner was calculated using the strain-life curves based on the work of Manson.⁵ Strain-life curves were developed for a variety of material properties and surface conditions. The results indicate that a liner life of 109 hours is achievable based on reduced material properties and a notched surface. The use of mean material properties instead of -3 σ properties increases liner life to 500 hours. This is based on a thermal cycle rate of one cycle per hour. Additional large increases in life are calculated by assuming smooth rather than notched material.

Fabrication

The liner is composed of a series of Lamilloy sheets welded together. The seams between adjacent sheets are arranged to be at an angle to the flow so that there is always an air film flow over the narrow weld joint. The liner ring portions, composed of Lamilloy of varying permeability were hydroformed to the proper shape and then welded together to form the complete liner. Hydroforming was necessary, rather than spinning, because of the particular liner geometry chosen for this combustor. A less convoluted liner could probably be spun, which is a simpler fabrication procedure

than hydroforming. The finished liners are shown in figure 5. Figure 5(a) shows the inner liner and figure 5(b) shows the outer liner. The stiffening rings can be clearly seen in figure 5(b).

Results and Discussion

For the first test, the liner was painted with a temperature indicating paint, as shown in figure 5. The first test was to be very brief and color changes in the temperature indicating paint would locate liner hot spots and positions where thermocouples would be installed to monitor future tests. The first test was conducted at an inlet-air pressure of 7.9 atmospheres, inlet-air temperature of 895 K and an average combustor exit temperature of 1700 K. The test time was only about 10 minutes, long enough to ensure that the paint would undergo the appropriate color changes. When examined after this test, both the O.D. and I.D. liners were uniformly the same color with the exception of some slight color differential in narrow regions at each weld joint. The color change indicated that the hottest portions of the liner were only about 180 K above the inlet-air temperature. The remainder of the liner showed only a uniform color indicative of very low thermal gradients. It was apparent that this test was not severe enough to pinpoint areas other than liner weld joints where thermocouples should be located. Therefore, the liner was cleaned and repainted with temperature indicating paint preparatory for a test at higher combustor exit temperatures. In addition, three thermocouples were installed on both the O.D. and I.D. liners. These thermocouples were placed in liner weld joints between Lamilloy panels (see fig. 6). The operating conditions for this test were inlet-air pressure of 7.9 atmospheres, inlet-air temperature of 895 K and combustor average exhaust temperature was varied upwards from 1700 to 2215 K in several steps. Substantial color changes were obtained this time and figure 7 shows the liner with isothermal lines on the surface. Figure 8 is a plot of the readings of the O.D. and I.D. liner thermocouples at the two combustor exit temperatures. Two test points were obtained: the first at an average exit temperature of 1719 K to confirm with thermocouples the temperatures indicated by paint in the previous test and second a test at 2215 K average exit temperature to force pronounced color changes in the paint. As shown in figure 8, the liner temperatures at the lower combustor exit temperature are generally in agreement with those temperatures indicated by the paint. That is, the weld areas were at least 180 K hotter than the inlet-air temperature. At the higher combustor exit temperature, the I.D. liner hot spot was about 285 K above the inlet-air temperature or a metal temperature of 1180 K (1665° F). The results obtained with the outer liner are shown in figure 8(b). Two thermocouples on this liner failed during the higher combustor exit temperature test. The outer liner tended to operate slightly hotter than the inner liner, but as before, the hottest region is the combustor exit portion of the liner. The maximum indicated temperature was 380 K above the inlet-air temperature or a metal temperature of 1275 K (1830° F).

Figure 9 compares the performance of the Lamilloy liner with that of a conventional step louver liner at virtually identical operating

conditions. As before, the results are shown as metal temperature minus the inlet-air temperature along the length of the liner. The distribution of cooling air is significantly different for the two liners which accounts for some of the observed differences. The amount of cooling air was also different for the two liners and this is listed in table II. A comparison of the two inner liners, figure 9(a), shows that the step-louver liner generally has as high a metal temperature as the Lamilloy liner in spite of 100 percent greater cooling air flow. The thermocouple in the Lamilloy liner, at the 7.3 centimeter position, is installed in a junction of two welds. This may account for the high metal temperatures of the Lamilloy liner at this upstream position. The outer liner comparison is shown in figure 9(b). At the lower exhaust gas temperature, the step-louver metal temperature was somewhat lower than the Lamilloy; the step-louver liner cooling air flow is about 60 percent greater.

As the exhaust gas temperature increased, the step-louver liner metal temperature increased at a greater rate than that of the Lamilloy liner. For example, at the 19 to 20 centimeter position when the exhaust gas average temperature increased from 1719 to 2215 K, the Lamilloy temperature increased only 110 K while the step-louver liner temperature increased 220 K. To date, durability of both the Lamilloy and the step-louver liners has been excellent. There has been no indication of separation of the metal layers in the Lamilloy liner. Iron oxide dust (rouge) in the combustion air has not been any problem and there is no evidence of liner flow restriction in spite of the amount of material in the air stream. The step-louver liners have been extensively used, accumulating many hours and test cycles. These liners are also in excellent condition showing no evidence of cracking or tendency for warping that might reduce film-cooling.

Concluding Remarks

In tests conducted to date, the Lamilloy liner shows every indication of being able to withstand the high combustor gas temperatures and maintain acceptable wall-temperature levels while requiring less cooling air than a more conventionally designed step-louver liner. The test program at the 8 atmosphere pressure level is nearly complete. The combustor and the Lamilloy liner will be tested in the High Pressure Facility at pressure levels up to 40 atmospheres.

References

1. Environmental Protection Agency, "Control of Air Pollution for Aircraft Engines - Emission Standards and Test Procedures for Aircraft," Federal Register, Vol. 38, No. 136, Part II, July 17, 1973, pp. 19088-19103.
2. Cochran, R. P., Norris, J. W., and Jones R. E., "A High-Pressure, High-Temperature Combustor and Turbine-Cooling Test Facility," ASME Paper 76-WA/GT-4, July 1976.
3. Roberts, R., Peduzzi, A., and Vitti, G., "Experimental Clean Combustor Program, Phase II, Pratt and Whitney Aircraft, East Hartford, Conn., PWA-5418, Nov. 1976. (NASA CR-134969)

4. Mularz, E. J., Wear, J. D., and Verbulecz, P. W., "Pollution Emissions from Single Swirl-Can Combustor Modules at Parametric Test Conditions," NASA TM X-3167, Jan. 1975.
5. Manson, S. S., "Fatigue, A Complex Subject - Some Simple Approximations," Experimental Mechanics, Vol. 5, No. 7, July 1965, pp. 193-226

TABLE I. - LAMILLOY LINER DESIGN REQUIREMENTS

Maximum operating condition

Inlet-air temperature, K	900
Inlet-air pressure, atm	40
Combustor exit average temperature, K	2500
System pressure differential, percent	10
Maximum metal temperature, K	1310
Desired lifetime at maximum operating condition, hr.	100
Allowable cooling air flow rate, percent (Percent of total flow).	15-20
Flow factor, $\frac{w\sqrt{T}}{p}$, range, Kg/sec, K, atm	44-65

TABLE II. - COMPARISON OF LINER COOLING FLOW RATES

<u>Liner type</u>	<u>Inner liner</u>	<u>Outer liner</u>	<u>Total</u>
Lamilloy	4.7	7.5	12.2
Step-Louver	9.5	12.0	21.5

Values as percent of total combustor air-flow rate

REPRODUCIBILITY OF THE
CAL-PAGE IS POOR

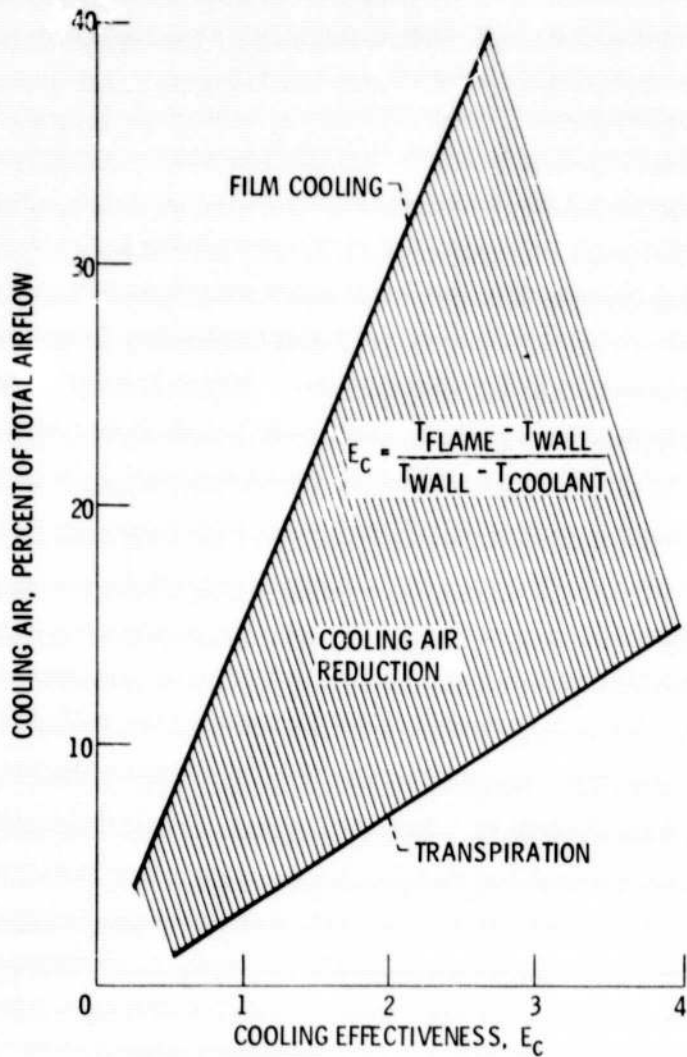
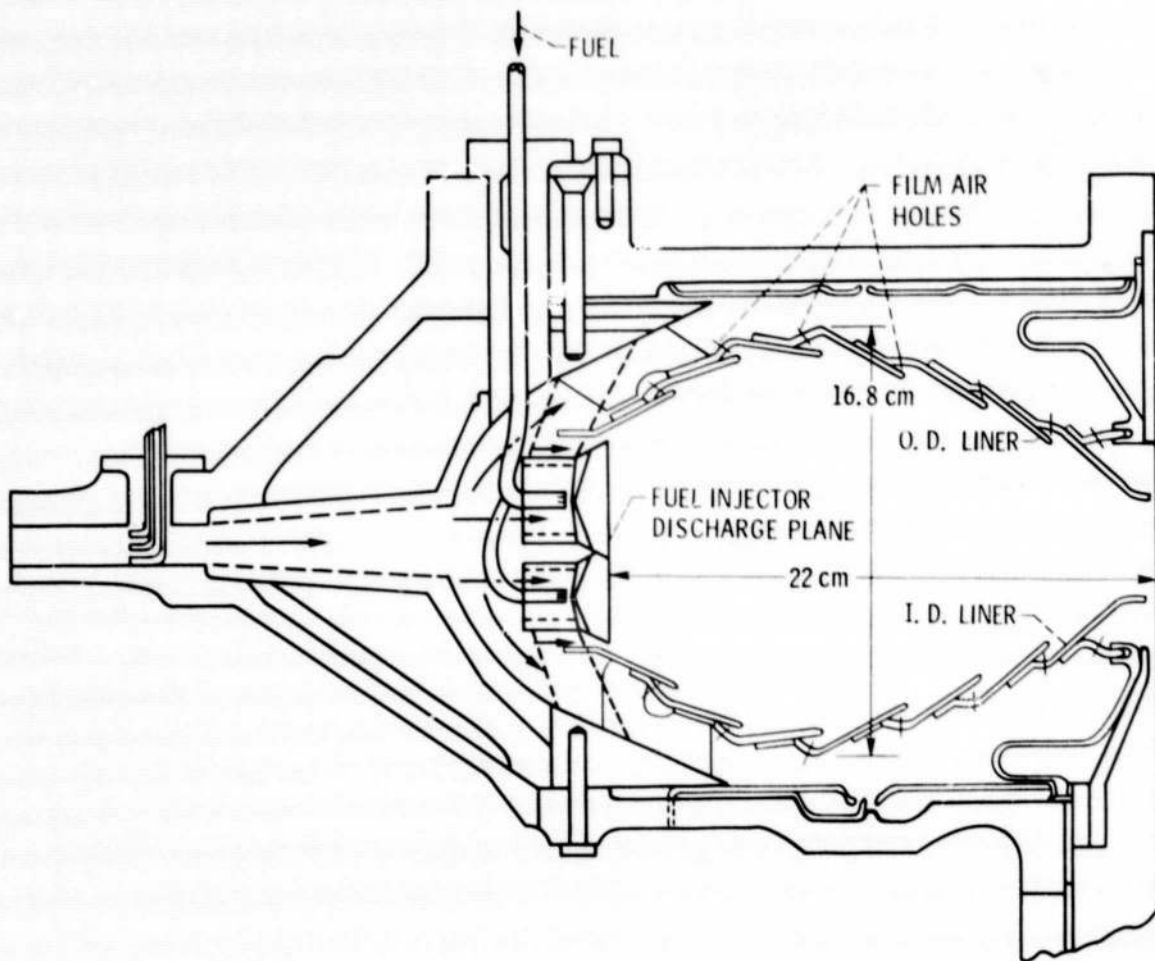
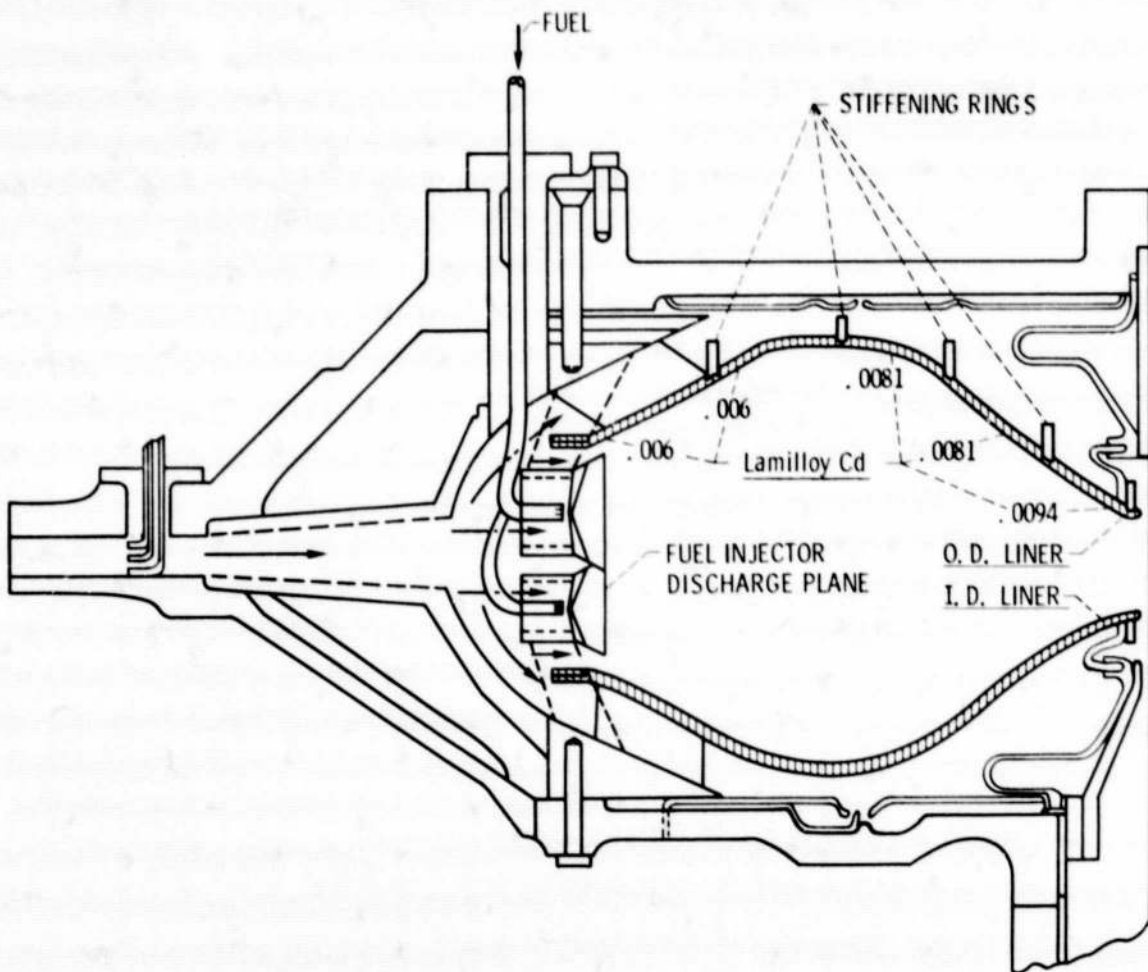

Figure 1. - Relative cooling performance of film cooled and transpiration cooled combustors.



(a) Step louver liner, A.

Figure 2 - Cross sectional sketch of high pressure combustor test section with combustor liner.



(b) Lamilloy liner.

Figure 2 - Concluded.

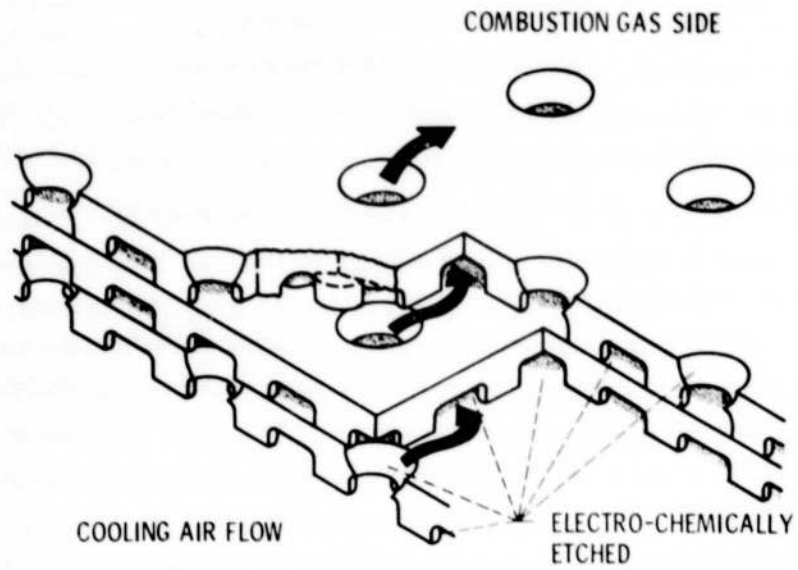

Figure 3 - Sketch of lamilloy construction and air flow path.

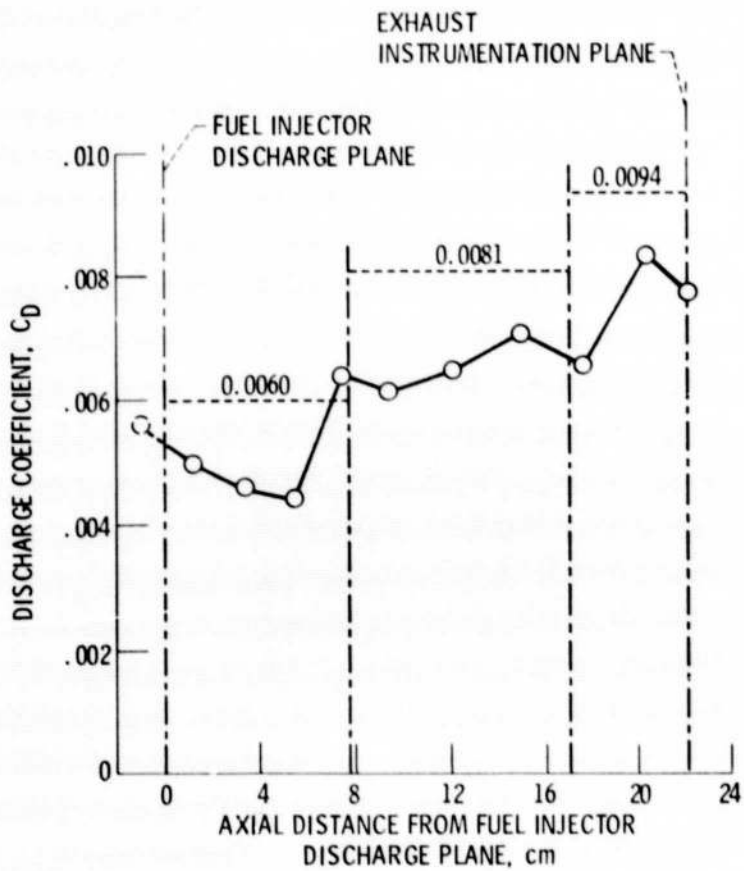
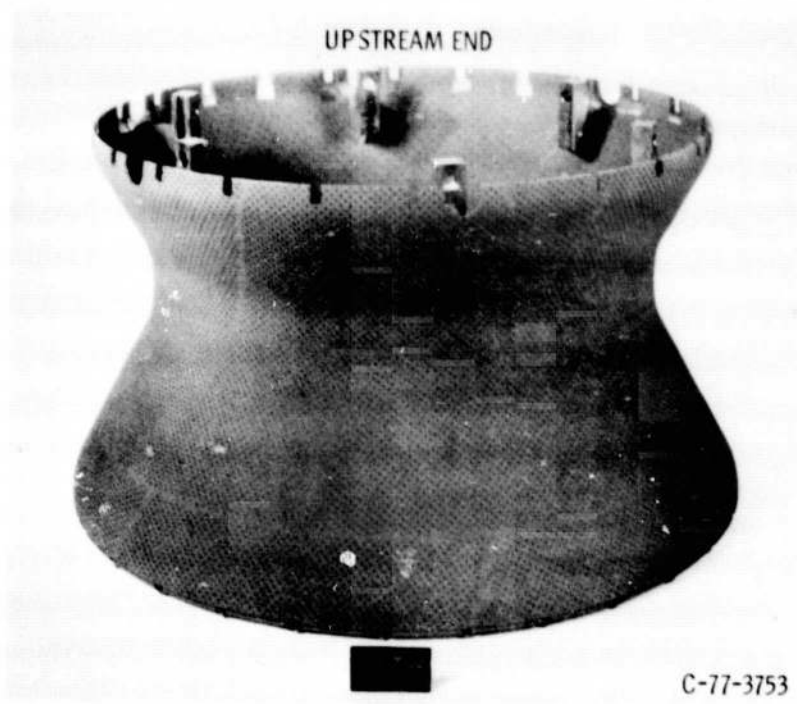

Figure 4 - Lamilloy permeability selection.

E-9706



(a) Inner liner.

Figure 5. - Lamilloy liner with temperature indicating paint.

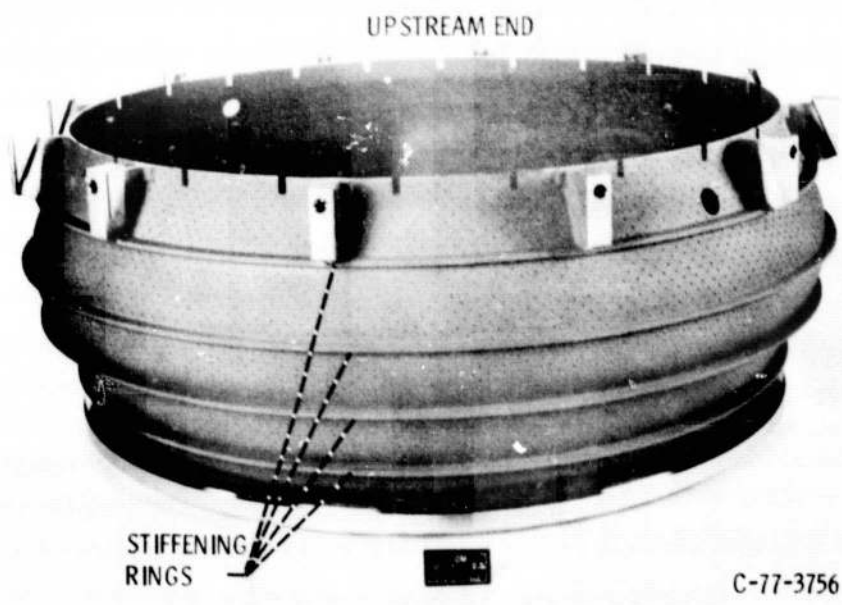

(a) OUTER LINER.

Figure 5. - Concluded.

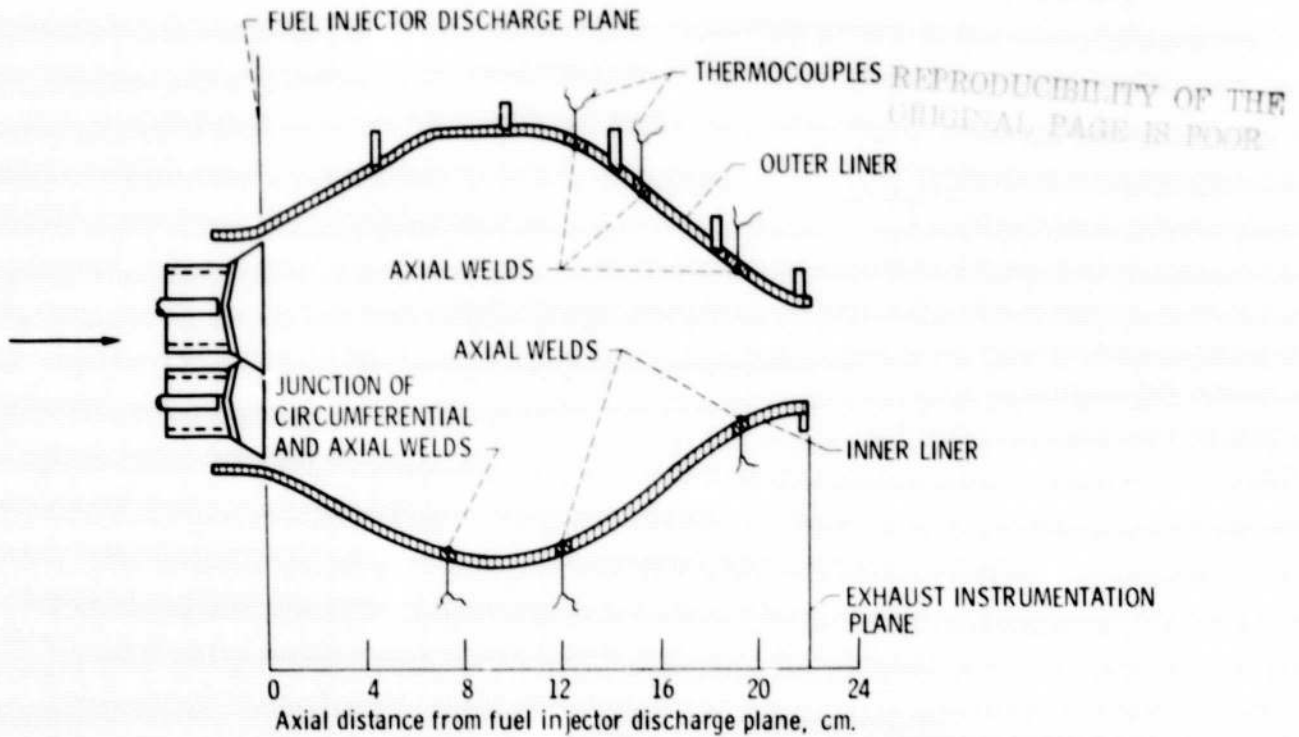
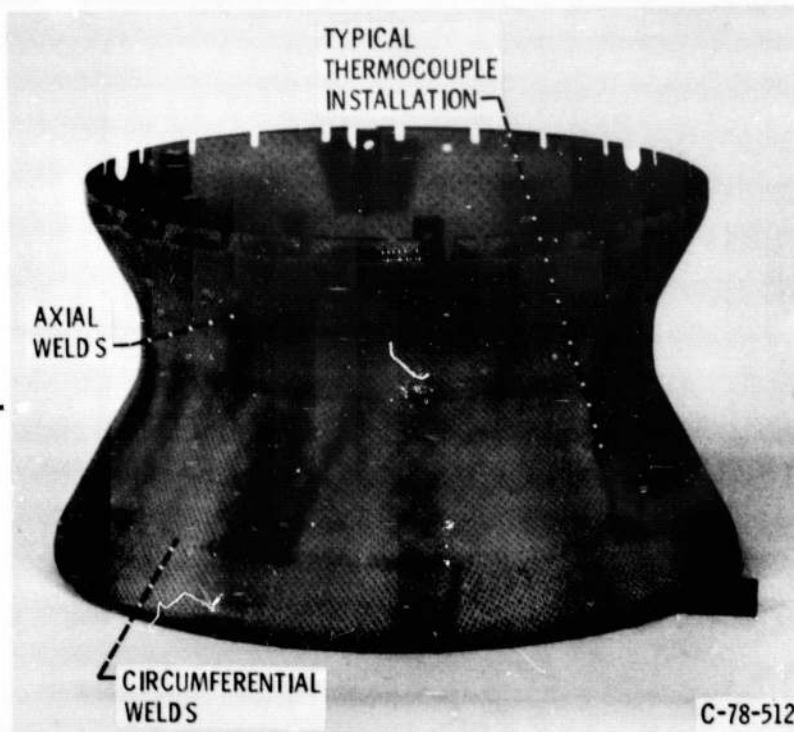

Figure 6. - Axial position of thermocouples installed on Lamilloy liner.



(a) INNER LINER.

Figure 7. - Lamilloy liner with temperature indicating paint after test to 2215 K average exhaust gas temperature.

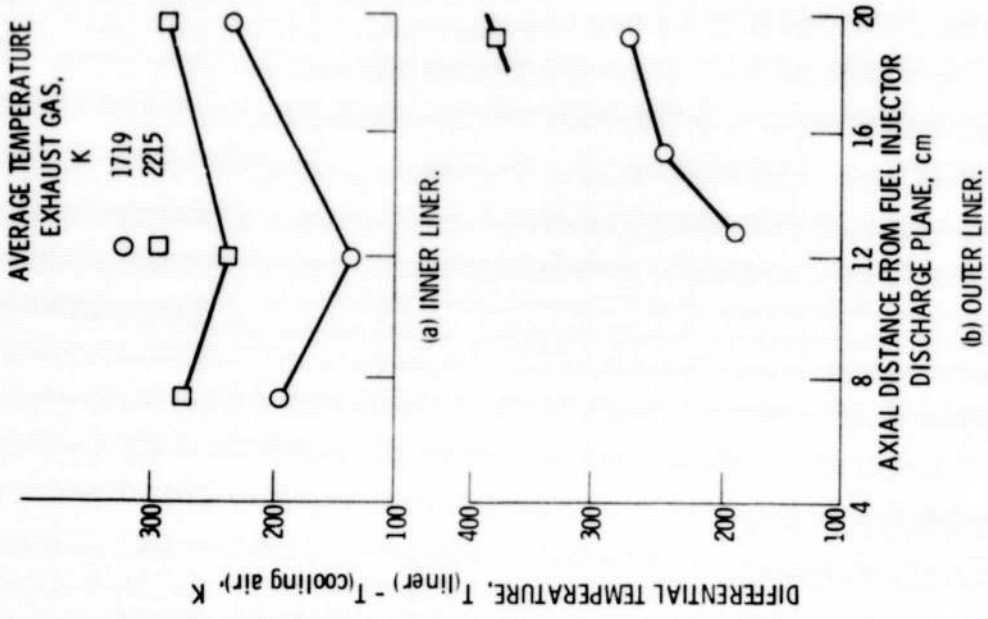
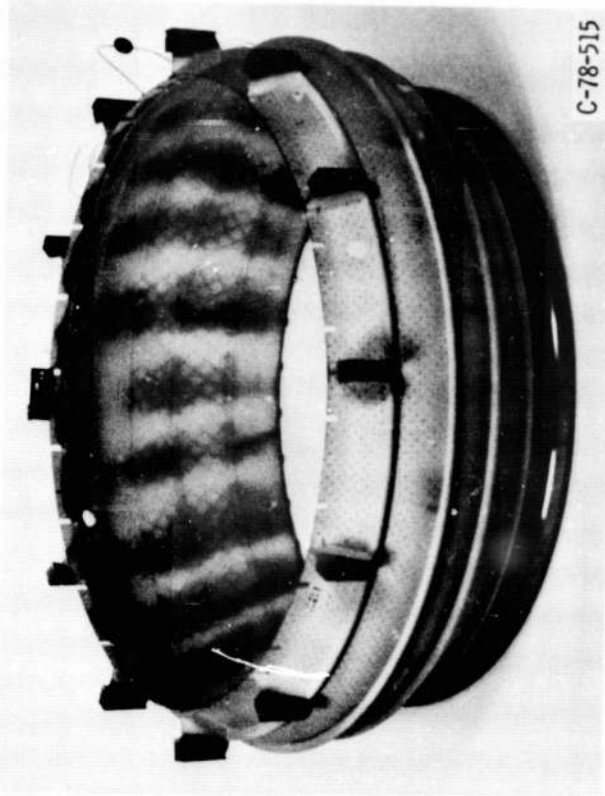

Figure 8. - Lamilloy liner temperature, as indicated by thermocouples, obtained during tests at two combustor exhaust gas temperatures. Inlet-air temperature, 895 K, combustion pressure, 7.9 atm.



C-78-515

(b) OUTER LINER.

Figure 7. - Concluded.

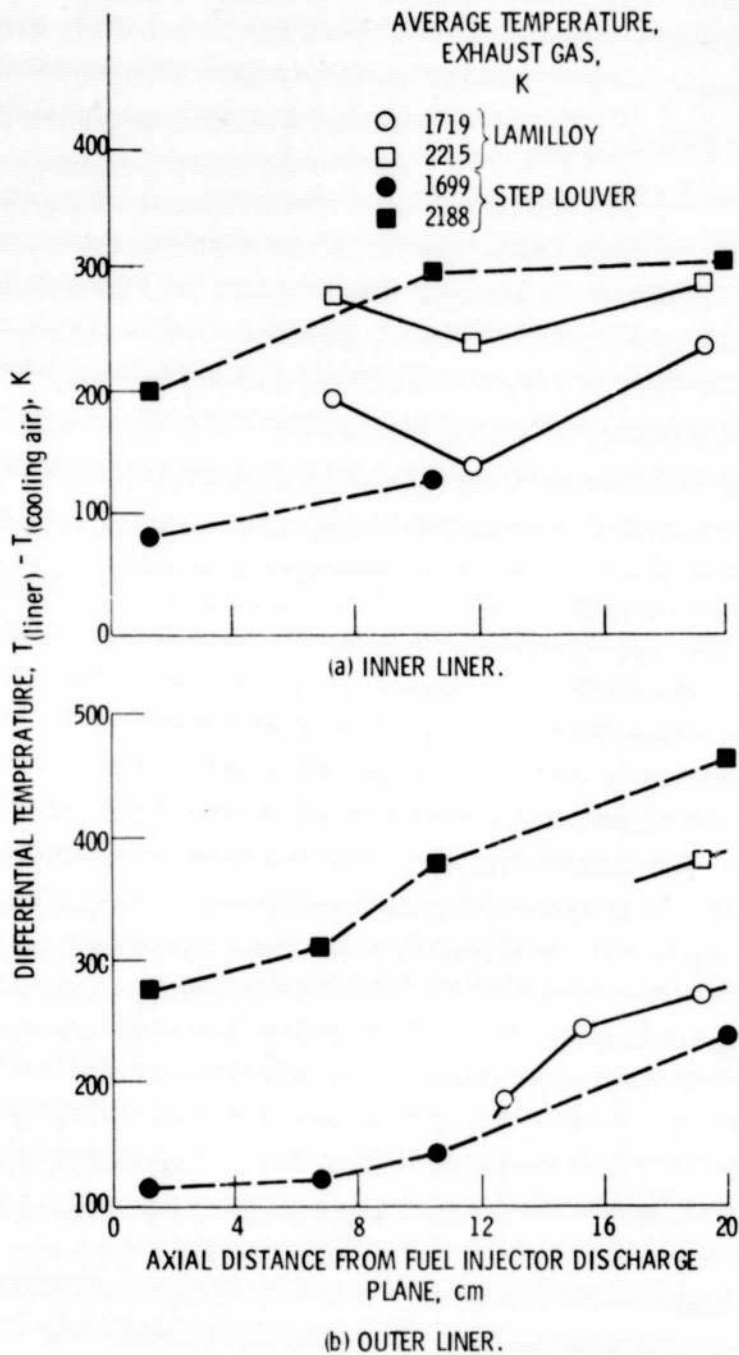

Figure 9. - Lamilloy and step-louver liner temperatures obtained by thermocouples at similar operating conditions. Inlet-air temperature, 895 K, combustion pressure, 7.9 atm.