

# Design Issues, Principles and Routing Challenges in Sensor Networks

Vinayak Musale <sup>1</sup>, Devendra Chaudhari <sup>2</sup>  
 Department of Computer Science and Engineering  
 Government College of Engineering  
 Sant Gadge Baba Amravati University, Amravati, Maharashtra  
 India  
 vinayak.musale@gmail.com <sup>1</sup>, ddsscc@yahoo.com <sup>2</sup>

**Abstract:** - Wireless Sensor Network consists of small battery powered nodes with capabilities of sensing, computation, and wireless communication. In WSNs, many routing, power management and data dissemination protocols have been specially designed where energy awareness is an essential design issue. To achieve better energy efficiency, the focus, however, has been given to the routing protocols which might differ depending on the application and network architecture. In this paper, we mainly focus on the various routing techniques, design challenges of routing protocols along with the performance issues of each routing technique in wireless sensor networks. Also present comprehensive analysis of different routing techniques used to achieve energy efficiency.

**Key-Words:** - Energy, Networks, Routing, Sensor, Wireless

## 1 Introduction

Now a days, due to recent technological advances, the manufacturing of small and low cost sensors became technically and economically feasible. The popularity of wireless sensor networks have increased tremendously due to the vast potential of the sensor networks to connect the physical world with the virtual world. A wireless sensor network is supposed to be made up of a large number of sensors and at least one base station. The sensors are autonomous small devices with several constraints like the battery power, computation capacity, communication range and memory.

Also they are supplied with transceivers to gather information from its environment and pass it on up to a certain base station, where the measured parameters can be stored and available for the end user. In most cases, the sensors forming these networks are deployed randomly and left unattended to and are expected to perform their mission properly and efficiently. As a result of this random deployment, the WSN has usually varying degrees of node density along its area [4].

Sensor networks are also energy constrained since the individual sensors, which the network is formed with, are extremely energy-constrained as well. The communication devices on these sensors are small and have limited power and range.

### 1.1 Communication architecture of a WSN

Sensors have the ability to communicate either among each other or directly to an external base-station (BS). Figure 1 shows the communication diagram of wireless sensor network.

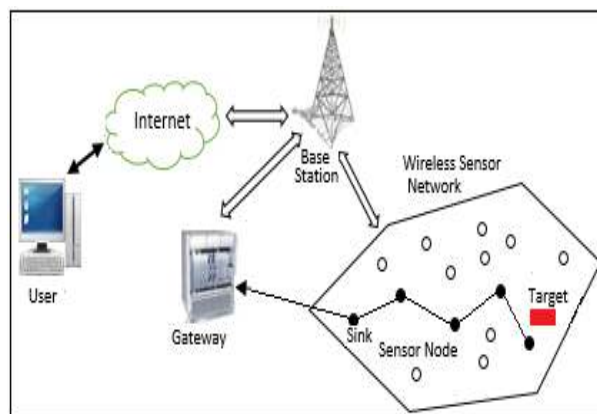

Figure 1. Communication Architecture of WSN

Sensor nodes are usually scattered in a sensor field, which is an area where the sensor nodes are deployed. Sensor nodes coordinate among themselves to produce high-quality information about the physical environment.

Each sensor node bases its decisions on its mission, the information it currently has, and its knowledge of its computing, communication, and energy resources. Each of these scattered sensor nodes has the capability to collect and route data either to other sensors or back to an external base station. A

base station may be a fixed node or a mobile node capable of connecting the sensor network to an existing communications infrastructure or to the Internet where a user can have access to the reported data. Deployment of the base station in a wireless sensor network is very important as all the sensor nodes handover their data to the base station for processing and decision making. Energy conservation, coverage of sensor nodes and reliability issues are taken care of during deployment of base station in sensor network.

## 1.2 Sensor Node Components

A wireless sensor network contains hundreds or thousands of these sensor nodes. These sensors have the ability to communicate either among each other or directly to an external base station. A greater number of sensors allows for sensing over larger geographical regions with greater accuracy. Figure 2 shows the schematic diagram of sensor node components. Basically, each sensor node comprises sensing, processing, transmission, mobilizer, position finding system, and power units. Sensor is a device which senses the information and pass it to the processing unit. Sensors are typically used to measure the changes in physical environmental parameters like temperature, pressure, humidity, sound, vibration and changes in the health parameter of person e.g. blood pressure and heartbeat.

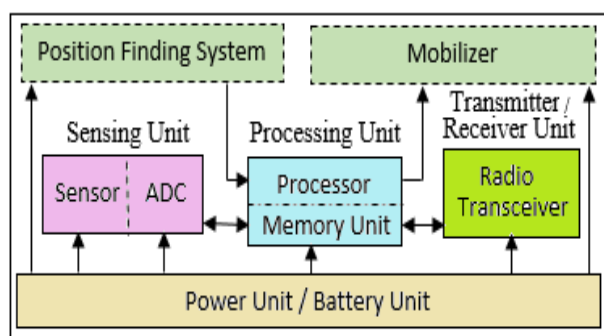

Figure 2. Schematic Diagram of Sensor Node

The analog to digital converters are used along with the processor and memory unit for processing input signals. The radio transceiver dissipate energy to run the transmitter radio electronics and power amplifier and the receiver dissipates energy to run the receive radio electronics. In the past few years, an intensive research that addresses the potential of collaboration among sensors in data gathering and processing and in the coordination and management of the sensing activity were conducted. However, sensor nodes are constrained in energy supply and bandwidth. Thus, innovative techniques that eliminate energy inefficiencies that would shorten the lifetime of the

network are highly required. Such constraints combined with a typical deployment of large number of sensor nodes pose many challenges to the design and management of WSNs and necessitate energy-awareness at all layers of the networking protocol stack. Routing in WSNs is very challenging due to the inherent characteristics that distinguish these networks from other wireless networks like mobile ad hoc networks or cellular networks.

First, due to the relatively large number of sensor nodes, it is not possible to build a global addressing scheme for the deployment of a large number of sensor nodes as the overhead of ID maintenance is high. Thus, traditional IP-based protocols may not be applied to WSNs. Furthermore, sensor nodes that are deployed in an ad-hoc manner need to be self-organizing as the ad hoc deployment of these nodes requires the system to form connections and cope with the resultant nodal distribution especially that the operation of the sensor networks is unattended.

Second, in contrast to typical communication networks, almost all applications of sensor networks require the flow of sensed data from multiple sources to a particular BS. This, however, does not prevent the flow of data to be in other forms (e.g., multicast or peer to peer).

Third, sensor nodes are tightly constrained in terms of energy, processing, and storage capacities. Thus, they require careful resource management. Fourth, in most application scenarios, nodes in WSNs are generally stationary after deployment except for, may be, a few mobile nodes. Nodes in other traditional wireless networks are free to move, which results in unpredictable and frequent topological changes. However, in some applications, some sensor nodes may be allowed to move and change their location (although with very low mobility).

Fourth, sensor networks are application specific, i.e., design requirements of a sensor network change with application. For example, the challenging problem of low-latency precision tactical surveillance is different from that required for a periodic weather-monitoring task.

Fifth, position awareness of sensor nodes is important since data collection is normally based on the location.

## 2 Related Work

There is a large number of current works, as well as efforts that are on the go, for the development of routing protocols in WSNs. There are several

surveys in the literature on routing protocols in WSNs and an attempt is made to present below and discuss the existing differences between them and our work.

Although there are some previous efforts for surveying the characteristics, applications, and communication protocols in WSNs [4], the scope of the survey presented in this paper is distinguished from these surveys in many aspects. The surveys in [3] and [2] addressed several design issues and techniques for WSNs describing the physical constraints on sensor nodes, applications, architectural attributes, and the protocols proposed in all layers of the network stack. However, these surveys were not devoted to routing only. Due to the importance of routing in WSNs and the availability of a significant body of literature on this topic, a detailed survey becomes necessary and useful at this stage.

In [7], the authors present a survey that is focused on the energy consumption based on the hardware components of a typical sensor node. They divide the sensor node into four main components: a sensing subsystem including one or more sensors for data acquisition, a processing subsystem including a micro-controller and memory for local data processing, a radio subsystem for wireless data communication and a power supply unit. Also the architecture and power breakdown as the solution to reduce power consumption in wireless sensor networks is discussed. They provide the main directions to energy conservation in WSNs. The paper is focused on the description of the characteristics and advantages of the taxonomy of the energy conservation schemes.

In [8], the design issues of WSNs and classification of routing protocols are presented. Moreover, a few routing protocols are presented based on their characteristics and the mechanisms they use in order to extend the network lifetime without providing details on each of the described protocols. Also, the authors do not present a direct comparison of the discussed protocols.

The paper in [9] presents the challenges in the design of the energy-efficient Medium Access Control (MAC) protocols for the WSNs. Moreover, it describes few MAC protocols for the WSNs emphasizing their strengths and weaknesses, wherever possible. However, the paper neither discusses the energy-efficient routing protocols developed on WSNs nor provides a detailed comparison of the protocols.

### 3 Routing Protocols in WSNs

Depending on the network structure, routing in WSNs can be divided into flat based routing, hierarchical based routing, and location based routing. In flat based routing, all nodes are typically assigned equal roles or functionality. In hierarchical based routing, however, nodes will play different roles in the network. In location based routing, sensor nodes' positions are exploited to route data in the network. A routing protocol is considered adaptive if certain system parameters can be controlled in order to adapt to the current network conditions and available energy levels.

In hierarchical networks routing protocols nodes are grouped into clusters. Every cluster has a cluster head the election of which is based on different election algorithms. The cluster heads are used for higher level communication, reducing the traffic overhead. Clustering may be extended to more than just two levels having the same concepts of communication in every level. The flat and hierarchical protocols are different in many aspects. At this point, the comparison among the different routing approaches based on various parameters for flat and hierarchical sensor networks, which is shown in Table 1.

Table 1. Flat based Vs Hierarchical Based Routing

Parameter	Routing Approach	
	Hierarchical Routing	Flat Routing
Scheduling	Reservation-based scheduling	Contention-based scheduling
Collision	Collisions avoided	Collision overhead present
Duty Cycle	Reduced duty cycle due to periodic sleeping	Variable duty cycle by controlling sleep time of nodes
Data Aggregation	Data aggregation by cluster head	Node on multi-hop path aggregates incoming data from neighbours
Routing	Simple but non-optimal routing	Routing can be made optimal but with an added complexity.
Synchronization	Requires global and local synchronization	Links formed on the fly without synchronization
Route Formation	Overhead of cluster formation throughout the network	Routes formed only in regions that have data for transmission
Latency	Lower latency as multiple hops network formed by cluster heads always available	Latency in waking up intermediate nodes and setting up the multipath

Energy Dissipation	Energy dissipation is uniform	Energy dissipation depends on traffic patterns
Control	Energy dissipation cannot be controlled	Energy dissipation adapts to traffic pattern
Channel Allocation	Fair channel allocation	Fairness not guaranteed

The comprehensive analysis of hierarchical based routing protocols has been shown in Table 2.

Table 2. Comprehensive Analysis of Hierarchical Based Routing Protocols

Scheme	Advantages	Drawbacks	Scalability	Mobility
Low-Energy Adaptive Clustering Hierarchy (LEACH)	Low energy, ad-hoc, distributed protocol	Not applicable to large network regions and the dynamic clustering brings extra overhead	Good	Fixed BS
Power Efficient Gathering in Sensor Information Systems (PEGASIS)	The transmitting distance for most of the node is reduced	No consideration of the base station's location about the energy of nodes when one of the nodes is selected as the head node	Good	Fixed BS
Threshold sensitive Energy Efficient sensor Network protocol (TEEN)	Works well in the conditions like sudden changes in the sensed attributes such as temperature	A lot of energy consumption and overhead in case of large network	Good	Fixed BS
Two-Tier Data Dissemination (TTDD)	It can be used for multiple mobile sinks in a field of stationary sensor nodes	Source node builds a virtual grid structure of dissemination points to supply data to mobile sinks	Low	No
Base-Station Controlled Dynamic Clustering Protocol (BCDCP)	Low energy consumption	Performance gain decreases as the sensor field area becomes small	Limited	No

Sleep / Wake Scheduling Protocol (Sleep / Wake)	Identifies bottleneck and significantly extends the network lifetime	Synchronization and scheduling will both affect the overall system performance	Good	No
Scaling Hierarchical Power Efficient Routing (SHPER)	Energy balance of the network	It does not support mobility	Good	Fixed BS
Distributed hierarchical agglomerative clustering (DHAC)	Longer network lifetime	Performance is worse as the network traffic is getting high	Good	No

## 4 Routing Challenges in WSNs

The wireless sensor networks have several restrictions as e.g., limited energy supply, limited computing power, and limited bandwidth of the wireless links connecting sensor nodes. One of the main design goals of WSNs is to carry out data communication while trying to prolong the lifetime of network. The design of routing protocols in WSNs is influenced by many challenging factors. These factors must be overcome before efficient communication can be achieved in WSNs. In reality the problem of routing is much more complicated, especially when a Multi-hop wireless network is concerned.

The following factors that make routing a more challenging task than just finding routing paths based on sink routes.

### ▪ Inconsistency of Network Topology:

It is caused due to node mobility, joining or leaving of nodes in the network. Also links among sensor nodes can be up and down. This link variations causes an inconsistency in network topology.

### ▪ Nondeterministic Routing Paths:

Routing path selection is based on network traffic, channel allocation, medium access control, power control etc. So it is more challenging to provide optimal solution for routing.

## 5 Design Issues for Routing Protocols

The design of energy efficient routing protocols is still an active research area. The following are some of the issues faced during the design of routing protocols that affect routing process in WSNs.

#### ▪ **Node deployment:**

The node deployment can be either deterministic or randomized. In deterministic deployment, the sensors are manually placed and data is routed through pre-determined paths. However, in random node deployment, the sensor nodes are scattered randomly creating an infrastructure in an ad hoc manner. Node deployment in WSNs is application dependent and affects the performance of the routing protocol.

#### ▪ **Data Aggregation:**

Data aggregation is the combination of data from different sources according to a certain aggregation function. Signal processing methods can also be used for data aggregation

#### ▪ **Energy consumption:**

The sensor nodes can use up their limited supply of energy performing computations and transmitting information in a wireless environment. So there is necessity of energy-conserving mechanisms for data communication and processing.

#### ▪ **Node Heterogeneity:**

Some applications might require a diverse mixture of sensors for monitoring temperature, pressure and humidity of the surrounding environment, detecting motion, and capturing the image or video tracking of moving objects. These special sensors can be either deployed independently or the different functionalities can be included in the same sensor nodes.

The use of heterogeneous set of sensors gives rise to many data routing problems and they have to be overcome.

#### ▪ **Connectivity:**

Sensor nodes are expected to be highly connected and it is maintained by possibly random distribution of nodes.

#### ▪ **Coverage:**

In WSNs, each sensor node obtains a certain view of the environment. A given sensor's view of the environment is limited both in range and in accuracy; it can only cover a limited physical area of the environment. Hence, area coverage is also an important design parameter in WSNs.

#### ▪ **Scalability:**

The number of sensor nodes deployed in the sensing area may be in the order of hundreds or thousands, or more. Any routing scheme must be able to work with this huge number of sensor nodes. In addition, sensor network routing protocols should be scalable enough to respond to events in the environment.

#### ▪ **Fault Tolerance:**

Some sensor nodes may fail or be blocked due to lack of power, physical damage, or environmental interference. The overall task of the sensor network should not get affected by the failure of sensor nodes. If many nodes fail, MAC and routing protocols must accommodate formation of new links and routes to the data collection base stations.

#### ▪ **Network Dynamics:**

Most of the network architectures assume that sensor nodes are stationary. The mobility of both base station and sensor nodes is sometimes necessary in many applications. Routing messages from or to moving nodes is more challenging since route stability becomes an important issue.

#### ▪ **Transmission Channel:**

In a multi-hop sensor network, communicating nodes are linked by a wireless medium. The traditional problems associated with a wireless channel (e.g., fading, high error rate) may also affect the operation of the sensor network.

#### ▪ **Quality of Service:**

The energy-aware routing protocols are required to lengthen the total network lifetime by reducing the energy dissipation in the nodes. Also required to assure data delivery within certain period of time and need to maintain the quality of data sent.

## 6 Design Principles for Routing Protocol

The enlisted some of the principles need to be considered in the design of routing protocols in order to resolve the challenging issues in routing protocols. These are as follows.

- Development of new routing metrics
- Emphasis on cross layer design
- Performing dynamic and adaptive routing
- Maintaining a stable and consistent network topology
- Deriving fault tolerant distributed routing algorithms
- Ensure scalability in routing protocols

## 7 Conclusion

From few years, routing in sensor networks is a new area of research with rapidly growing set of research results. In this paper, we presented a comprehensive analysis of hierarchical based routing protocols and challenges in routing. Overall, the routing techniques are classified in the categories like flat,

hierarchical, and location based routing protocols. The hierarchical protocols are suitable for sensor networks with heavy load and wide coverage area. We also highlight the design issues in routing paradigm, as well as the advantages and disadvantages of hierarchical routing technique. Although many of these routing techniques look promising, there are still many challenges that need to be solved in the sensor networks. We enlisted some of the principles need to be considered in the design of routing protocols pinpointed future research directions in this regard.

### **References:**

- [1] T. N. Qureshi, T. Shah and N. Javaid. EESAA: Energy Efficient Sleep Awake Aware Intelligent Sensor Network Routing Protocol. In Proceedings of 15th International Multi Topic Conference (INMIC), Islamabad, PK (13th to 15th December 2012).
- [2] Nikolaos A. Pantazis, Stefanos A. Nikolidakis and Dimitrios D. Vergados, "Energy-Efficient Routing Protocols in Wireless Sensor Networks: A Survey," IEEE Communications Surveys & Tutorial, vol 3, pp. 1-41, 2012.
- [3] X. H. Wu, S. Wang, "Performance comparison of LEACH and LEACH-C protocols by NS2," In Proceedings of 9th International Symposium on Distributed Computing and Applications to Business, Engineering and Science. Hong Kong, China, pp. 254-258, 2010
- [4] P. Minet, "Energy Efficient Routing", in Ad Hoc and Sensor Wireless Networks: Architectures: Algorithms and Protocols. Bentham Science 2009.
- [5] L. Almazaydeh, E. Abdelfattah, M. Al-Bzoor, A. Al-Rahayfeh, "Performance Evaluation of Routing Protocols in Wireless Sensor Networks," Computer Science and Information Technology, 2010, Vol. 2, Issue 2, pp. 64-73.
- [6] A. Perrig, R. Szewzyk, J.D. Tygar, V. Wen, and D. E. Culler, "SPINS: security protocols for sensor networks". Wireless Networks Volume: 8, pp. 521-534, 2000.
- [7] A. Manjeshwar and D. P. Agarwal, "TEEN: a routing protocol for enhanced efficiency in wireless sensor networks," In 1st International Workshop on Parallel and Distributed Computing Issues in Wireless Networks and Mobile Computing, April 2001.
- [8] S. Dulman, T. Nieberg, J. Wu, P. Havinga, "Trade-Off between Traffic Overhead and Reliability in Multipath Routing for Wireless Sensor Networks", WCNC Workshop, New Orleans, Louisiana, USA, March 2003.
- [9] Jamal N. Al-Karaki, A.E. Kamal, "On the Correlated Data Gathering Problem in Wireless Sensor Networks", to appear in the Proceedings of The Ninth IEEE Symposium on Computers and Communications, Alexandria, Egypt, July 2004.
- [10] S. Kim, J. S. Ho, and A. S. Y. Poon, "Midfield wireless powering of subwavelength autonomous devices," PhRvL, vol. 110, no. 20, p. 203905, 2013.
- [11] H. Taheri, P. Neamatollahi, O. M. Younis, S. Naghibzadeh and M. H. Yaghmaee, "An energy aware distributed clustering protocol in wireless sensor networks using fuzzy logic", Ad Hoc Networks, Vol.10, No.7, 2012, pp.1469-1481.