

## Design of a 100 GWh wave energy plant

Jayashankar.V<sup>1,\*</sup>, Mala.K<sup>1</sup>, Kedarnath.S<sup>1</sup>, Jayaraj.J<sup>1</sup>, Omezhilan.U<sup>2</sup>, Krishna.V<sup>1</sup>

<sup>1</sup> IIT Madras, Chennai, India

<sup>2</sup> Kings College of Engg., Pudukottai, India

\* Corresponding author. Tel: +91-44-22574427, Fax: +914422574427, E-mail:jshankar@ee.iitm.ac.in

**Abstract:** The near shore Oscillating Water Column (OWC) based wave energy plant shows enormous promise for the commercialization of wave energy. The design details of such a plant, with an average incident energy of 24 kW/m and capable of producing 100 GWh over a two year period are described. The caisson, which could be a part of a breakwater, is constructed in a modular fashion in widths of 20 m. The power module is built around a 4.5 m diameter twin unidirectional impulse turbine with a rating of 900 kW. A key feature of the design is to combine the output from several OWCs into a single power module. Simulations show that the efficiency of the turbine can exceed 60 % from 10 to 100 % of the rated power. It is shown that a breakwater length of about 660 m with 11 such turbine generators is sufficient to meet the design requirement, with an overall wave to wire efficiency of about 36 %. The power electronics interface to the grid could be implemented with doubly fed induction generators or variable speed synchronous generators directly obtainable from the wind power industry. Laboratory experiments on a model turbine are used to validate the main claims.

**Keywords:** OWC, twin unidirectional turbine topology, doubly fed induction machine

### Nomenclature

$C_a$ input coefficient	$DP$ differential pressure..... Pa
$C_t$ torque coefficient	$J$ moment of inertia ..... $kgm^2$
$\phi$ flow coefficient	$T$ torque ..... Nm
$\eta$ efficiency	$w$ angular velocity..... $rad \cdot s^{-1}$
	$Q$ volumetric flow rate..... $m^3 \cdot s^{-1}$

### 1. Introduction

The Oscillating Water Column (OWC) based wave energy plant is probably the most researched approach in the conversion of wave energy to electrical energy. Several documented demonstration plants around the world, in places such as Japan [1], India [2], UK [3] and Portugal [4], attest to the allure of the concept. In this approach, the energy conversion occurs in three steps. The variations in sea surface elevation (ocean waves) are converted to pressure fluctuations in the OWC. A turbine converts this pneumatic power into mechanical shaft power and an electrical generator coupled to the turbine gives electrical power. The overall efficiency of the conversion from wave to wire is given by

$$\eta = \eta_a * \eta_t * \eta_g \quad (1)$$

where  $\eta_a$  is the efficiency of the OWC

$\eta_t$  is the efficiency of the turbine, and

$\eta_g$  is the efficiency of the generator

The hydro dynamic efficiency of the plant can exceed 60% as reported in [1]. Table1 shows a summary of the reported experience with the OWC based wave energy plants mentioned above. The two different configurations of the Indian wave energy plant are shown in Fig. 1. The vertical axis 2 m Wells turbine power module is shown in Fig. 1a, while Fig. 1b shows the horizontal axis twin 1 m Wells turbine power module.

Table 1. Design details and performance of OWC plants

Plant	OWC effective area (dimension)	$\eta_{\text{OWC}}$	Power module		Comment
			Turbine	Generator	
Sakata port	115 m <sup>2</sup> (6 x 20)	> 60%	Twin 1.337m Wells'	60 kW 1800 - 2000 rpm	Variable speed
Vizhinjam	67.5 m <sup>2</sup> (6.75 x 10)	> 60%	2 m Wells	110 kW 1000 rpm	Fixed speed
Pico	144 m <sup>2</sup> (12 x 12)	> 50%	2.3 m Wells	440 kW 750 - 1500 rpm	Variable speed
LIMPET	126m <sup>2</sup> 6x 21	> 60%	2.6 m Wells	2 x 250 kW 1050 rpm	Fixed speed



Fig. 1a. The Indian wave energy plant, 1991



Fig. 2b. The Indian wave energy plant, 1996

A recent study by the Carbon Trust [5] also describes the features of possible designs of near shore OWC plants. A generic OWC is assumed to perform with hydrodynamic efficiency of 42 %, utilizing a turbine operating with 65 % efficiency and a generator having 91 % efficiency, yielding an overall efficiency (wave to wire) of 24.8 %. In this work we consider the design of a plant which could yield a wave to wire efficiency of 36 % based on a new power module design. The proposed design satisfies the requirement for a plant producing 100 GWh over a two year period [6].

## 2. The twin unidirectional impulse turbine topology

An impulse turbine for use with unidirectional flow was proposed in [7]. The characteristics of the turbine under steady flow are shown in Fig. 2. The efficiency of the turbine is also illustrated in Fig. 2. It is seen that the turbine is capable of operating with efficiency better than 60%, for flow coefficients ranging from 0.317 to 0.948. A new power module incorporating two such turbines was proposed in [8] and the experimental results were shown in [9]. Conceptually, the topology uses two unidirectional turbines in conjunction with fluidic diodes as shown in Fig. 3. The fluidic diode assists in ensuring unidirectional airflow across the turbines, allowing only negligible flow in the reverse direction. The guide vane/ rotor blade profile also provides a significant contribution towards the higher impedance in the reverse direction. A consequence of this fact is the high efficiency in each cycle.

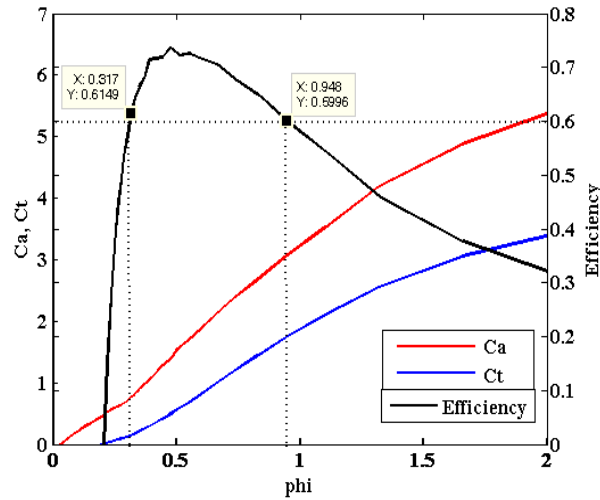

Fig. 2. Characteristics of unidirectional impulse turbine

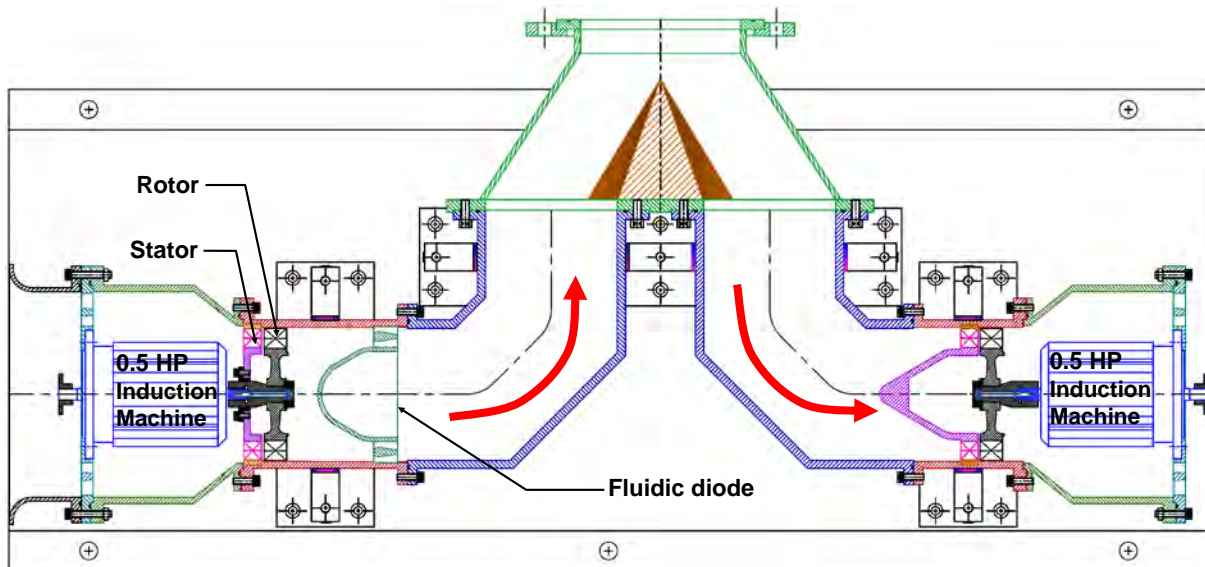

Fig. 3. Sectional view of the laboratory model of twin unidirectional turbine topology

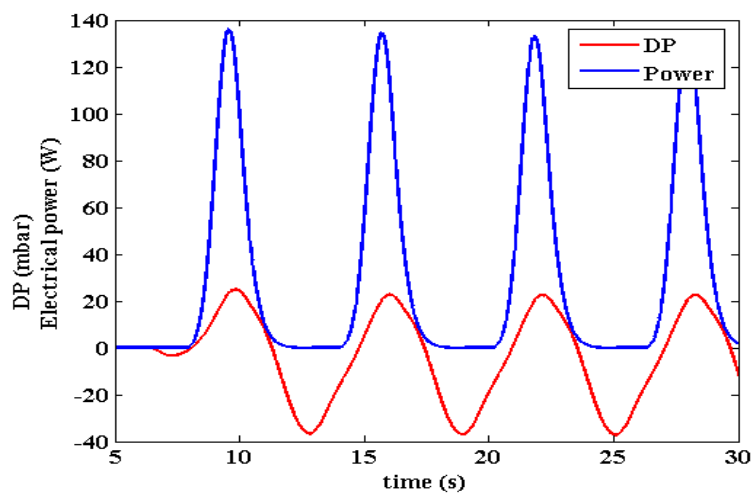

Fig. 4. Measured parameters of single 165 mm turbine, coupled to a 375 W dc generator

The laboratory results on a 165 mm turbine with induction generator [9] showed that the concept was valid. In order to characterize the forward and reverse flow characteristic of the unidirectional turbine, an experiment was performed with a single turbine subjected to oscillating flow in a facility described in [9]. The turbine was coupled to a 180 V, 375 W, 3000 rpm dc generator with a fixed resistive load. As seen in Fig. 4, the positive stroke produces a power of 135 W with a differential pressure of 2.2 kPa. In the reverse flow the differential pressure is 3.7 kPa, thus clearly highlighting the differing impedances. In this experiment the generator was. A further realisation was the notion that the unidirectional turbine topology permits the summing of pneumatic outputs from different OWCs with a single turbine of a large diameter.

### 3. Design of a power module for a 20 m OWC

The incident yearly wave power input is assumed to be 24 kW/m. Thus the average wave power for an OWC with 20 m opening is 480 kW. With an OWC efficiency of 0.6, the average pneumatic power is 288 kW. This would give an average mechanical output of 184.3 kW with 64% turbine efficiency with turbine diameter of 2.6 m. Assuming that the plant should have the capability to withstand incident wave energy as high as 40 kW /m occasionally, the mechanical output will be 307 kW. With three OWCs feeding a single turbine the rating is 922 kW. The turbine diameter is now 4.5 m. It may be remembered that the average mechanical output of this combination would be 553 kW, corresponding to 24 kW/m of incident wave power.

We now consider the simulation of a turbine of diameter 4.5m when connected to an induction generator. Fig. 5 shows the basic block diagram of the simulation and has been extensively described and validated in [10]. The input to the program is the differential pressure time series obtained from a typical recording in the Indian wave energy plant. The record is scaled in order to cater to the overall range that will be encountered in the proposed design.

The program evaluates the expression

$$J \frac{dw}{dt} = T_t - T_g - T_l \quad (2)$$

where J is the moment of inertia of the system

$T_t$  and  $T_g$  are the turbine and generator torques

$T_l$  is the term accounting for losses

The operation of the power module is highlighted in Fig.6, which illustrates the time variation of the relevant parameters of the power module. The differential pressure (DP) across the turbine, the pneumatic power ( $P_a$ ), the mechanical power ( $P_m$ ) and the flow coefficient ( $\Phi$ ), are all illustrated in Fig.6. In this run of 8 minutes, the average mechanical power from the turbine was approximately 500 kW which is close to the yearly average power. It may also be noted that the peak mechanical power obtained was around 3.4 MW, which is very similar to the power ratings in wind energy industry as well. By allowing summation of the pneumatic outputs of multiple OWCs with a larger diameter turbine, the twin turbine topology reaches power ratings similar to those seen in the wind power industry. This would enable the direct utilization of wind power modules in OWC based wave energy plants as well.

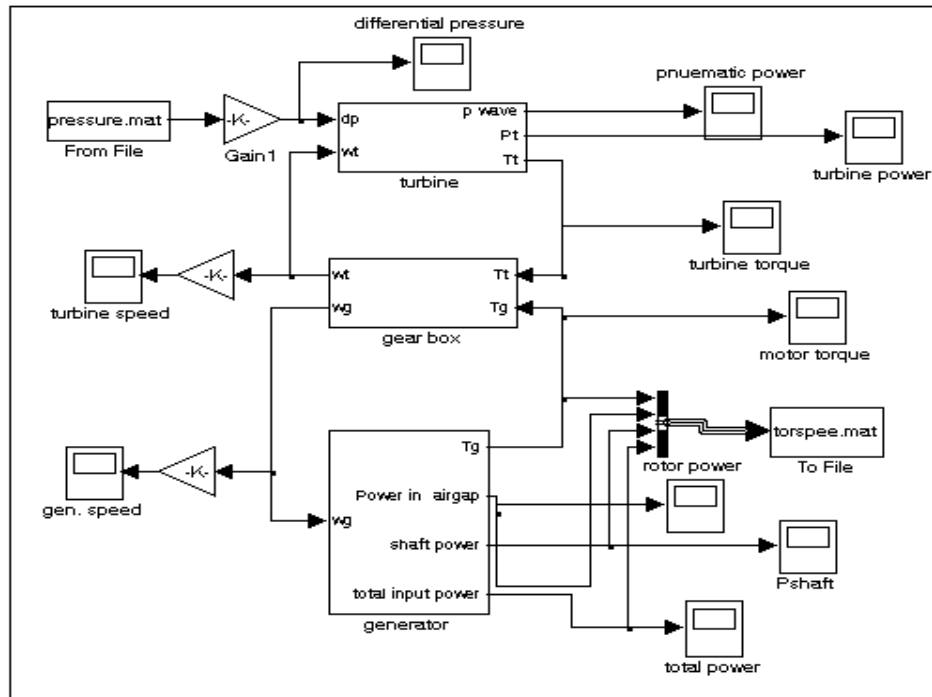

Fig. 5. Block diagram of simulation of 4.5 m diameter turbine coupled to an induction generator

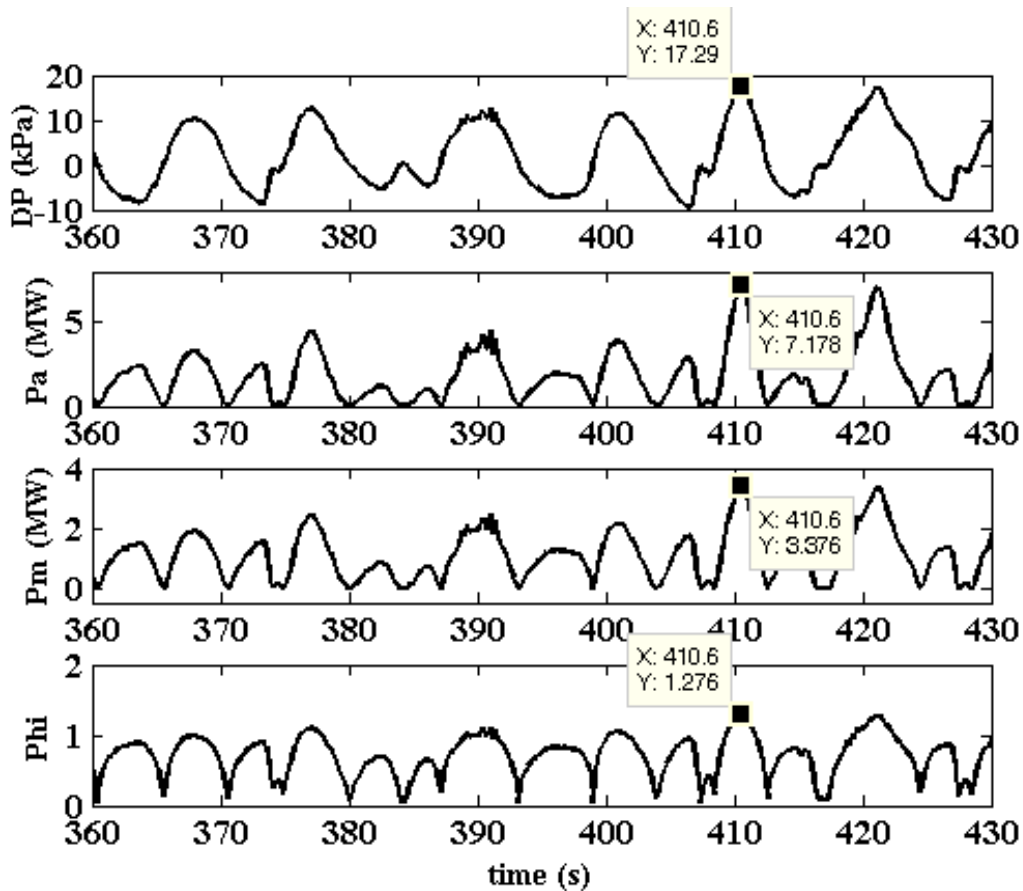

Fig. 6. Simulated plots highlighting the operation of 4.5 m, 200 rpm turbine

The simulation is repeated for several values of pneumatic incident energy. Fig. 7 shows the mechanical power over the range of incident pneumatic power for speeds of 150 rpm, 200 rpm and 375 rpm. The upper axis corresponds to the incident wave power with an assumed hydrodynamic efficiency of 0.6 for the OWC. It can be seen from Fig. 7 that higher speeds of operation tend to give better efficiency at increased power levels, while lower speeds tend to give better efficiency at reduced wave power levels. This point is clearly delineated in Fig. 8, which shows the average efficiency. It is evident from the graph that efficiency can be significantly improved over a wide range of input wave power, if the turbine speed is made to vary, as opposed to a fixed speed operation. It is very important to note that high efficiency can be obtained by operating over a range of speeds varying by nearly a factor of 2. Variable speed power modules from the wind power industry may be easily adapted for this purpose.

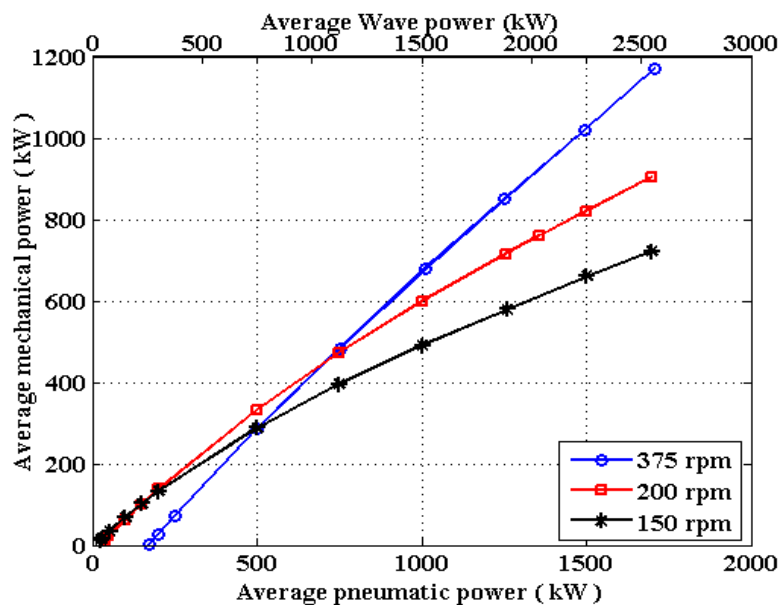

Fig. 7. Average mechanical powers for the variable speed operation of the 4.5 m turbine

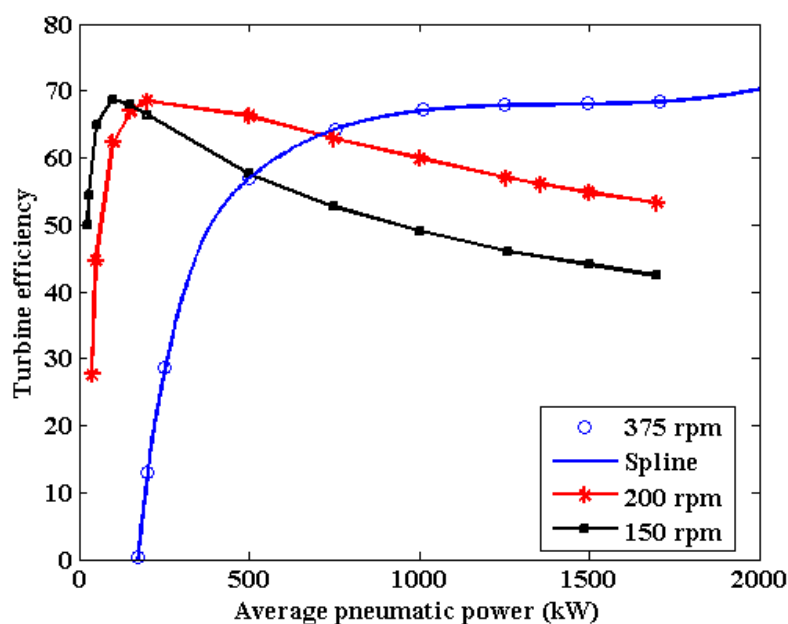

Fig. 8. Average turbine efficiency for the variable speed operation of the 4.5 m turbine

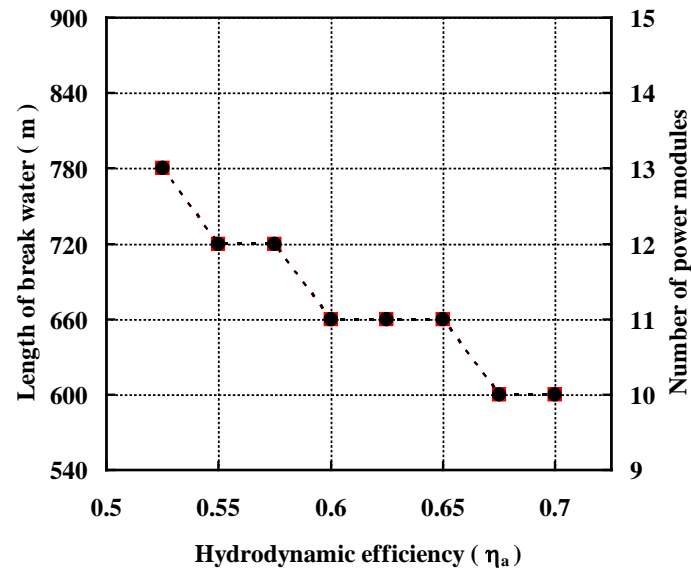

Fig. 9. Influence of the hydrodynamic efficiency on the modular design of the 100 GWh wave energy plant

#### 4. Implications for a 100 GWh plant

It was shown in the previous section that a single 4.5 m diameter turbine could be designed for an average power of 553 kW. Taking a generator efficiency of 94%, each turbine generator set (i.e. the power module) would now be capable of generating 519 kW of electrical power on average. A requirement of 100 GWh over two years implies a 5707 kW plant with 100 % availability. Thus 11 turbine generators will be sufficient to produce the requirement of 100 GWh. A breakwater integrated design of such a plant would cover a length of 660 m, operating at 60 % hydrodynamic efficiency. The modular design is not significantly altered even if the efficiency of wave capture is different. Fig. 9 indicates the number of power modules required to cater to the requirement of 100 GWh, over the expected range of hydrodynamic efficiencies. The size of the corresponding break water is also indicated in Fig.9.

The important features are that the power electronics interface is directly obtainable from the wind industry. This implies that a doubly fed machine which can cater to such a speed variation of 200 to 375 rpm will be adequate for this purpose. With a peak rating of 922 kW doubly fed machines as well as permanent magnet synchronous machines with converters are available. These correspond to the Type C and Type D types of power modules in the wind industry [11].

#### 5. Conclusions

A twin unidirectional turbine power module in an OWC plant can produce an average efficiency of above 60% over a wide range of input excitation. The twin unidirectional turbine topology allows a single turbine generator set, to capture the pneumatic outputs of multiple OWCs. Eleven turbine generator sets of 4.5 m diameter, spread over a 660 m breakwater integrated OWC plant, are sufficient to produce 100 GWh over a period of two years. Variable speed operation is suggested to maintain high efficiency over a wide range of expected incident wave power. Doubly fed induction machines as well as the synchronous machines, commonly used in wind power industry, can be used for the power module in the wave energy plant.



## Annexure

The equivalent circuit parameters of the 6 kV, 12.5 kW induction generator used in the simulation of the 4.5 m unidirectional turbine were taken from [12]. They are as follows.

$$R_1 = R_2 = 0.018 \Omega$$

$$X_1 = X_2 = 0.18 \Omega$$

$$X_m = 14.4 \Omega$$

## Acknowledgement

The authors wish to express their heart felt gratitude to Dr. T.Setoguchi, Saga University, Japan for all his help over the years. The authors would also like to thank the NIOT, India for their support in developing the necessary experimental facility required for this research.

## References

- [1] Ohno H., Funakoshi T., Saito K., Oikawa K., and Takahashi S., Interim report on the Second Stage of Field Experiments on a Wave Power Extracting Caisson In Sakata Port, *ODEC*, 1993, pp. 173-182.
- [2] Ravindran M., Jayashankar V., Jalihal P. and Pathak A.G., The Indian Wave Energy Program – an overview, *Teri Information Digest on Energy* 7(3), 1997, pp.173-188.
- [3] Heath, T., Whittaker, T.J.T and Boake, C.B., The design, construction and operation of the LIMPET wave energy converter, *Proceedings of the 4<sup>th</sup> European Wave Energy Conference*, 2000, pp. 49-55.
- [4] Le Crom, Brito-Melo A.,Neumann F., Sarmiento A.J.N.A., Portuguese grid connected OWC power plant: Monitoring Report, *Proceedings of the 20<sup>th</sup> International Offshore and Polar Engineering Conference*, 2010.
- [5] *Marine Energy Challenge: Oscillating Water Column wave energy converter evaluation report*, © The Carbon Trust, 2005.
- [6] The Saltire prize challenge. Available online: <http://www.scotland.gov.uk/Topics/Business-Industry/Energy/Action/leading/saltire-prize>; April 1, 2003 [accessed 13.09.09].
- [7] Takao M., Setoguchi T., Kaneko K., Kim TH, Maeda H. and Inoue M., Impulse turbine for Wave power conversion with Air flow rectification system, *International Journal of Offshore and Polar Engineering* 12(2), 2002, pp.142 – 146.
- [8] Jayashankar V., Anand S., Geetha T et al., A twin unidirectional topology for OWC based wave energy plants, *Renewable Energy* 34, 2009, pp. 692-698.
- [9] Mala K., Jayaraj J., Jayashankar V. et al., A twin unidirectional impulse turbine topology for OWC based wave energy plants - Experimental validation and scaling, *Renewable Energy* 36, 2011, pp. 307-314.
- [10] Anand S, Jayashankar V, Nagata S, Toyota K, Takao M, Setoguchi T., Performance estimation of bi-directional turbines for wave energy plants, *International Journal of Thermal Science* 15(4), 2007, pp.346 -52.
- [11] Michalke G., “Benefits for the development of wave and tidal energy conversion from the lessons learned in wind energy”, 3<sup>rd</sup> International Conference on Ocean Energy, 2010.
- [12] Ion Boldea, *Variable speed generators*, CRC press, 2006, pp.1-16.