

Syracuse University

**SURFACE**

---

Electrical Engineering and Computer Science –  
Theses

College of Engineering and Computer Science

---

5-2013

## Design of a Microstrip Bandpass Filter for 3.1-10.6 GHz Uwb Systems

Cem Cansever  
*Syracuse University*

Follow this and additional works at: [https://surface.syr.edu/eecs\\_thesis](https://surface.syr.edu/eecs_thesis)



Part of the [Electrical and Computer Engineering Commons](#)

---

### Recommended Citation

Cansever, Cem, "Design of a Microstrip Bandpass Filter for 3.1-10.6 GHz Uwb Systems" (2013). *Electrical Engineering and Computer Science – Theses*. 1.

[https://surface.syr.edu/eecs\\_thesis/1](https://surface.syr.edu/eecs_thesis/1)

This Thesis is brought to you for free and open access by the College of Engineering and Computer Science at SURFACE. It has been accepted for inclusion in Electrical Engineering and Computer Science – Theses by an authorized administrator of SURFACE. For more information, please contact [surface@syr.edu](mailto:surface@syr.edu).

## **Abstract**

In this thesis, ultra-wideband (UWB) microwave filters and design challenges are studied and, a microstrip UWB filter prototype design is presented. The UWB bandpass filter operating in the 3.6 GHz to 10.6 GHz frequency band is targeted to comply with the FCC spectral mask for UWB systems. The prototype filter is composed of quarter-wavelength spaced shunt stub transmission lines. The circuit is first simulated and optimized by using AWR DE simulation software tool. Then Sonnet EM Simulation and CST EM Simulation Tools are further utilized to obtain more accurate simulated results. The fabricated microstrip UWB bandpass filter is then measured using a vector network analyzer and results are presented. The prototype built can be used in UWB communications or localization systems.

DESIGN OF A MICROSTRIP BANDPASS FILTER  
FOR 3.1-10.6 GHz UWB SYSTEMS

by

CEM CANSEVER

Thesis

Submitted in partial fulfillment of the requirements for the degree of  
Master of Science in Electrical Engineering

Syracuse University  
May 2013

Copyright © Cem Cansever 2013  
All Rights Reserved

## **Acknowledgements**

First and foremost, I would like to thank my advisors Prof. Ercument Arvas and Dr. Hakan Pasa Partal. They shared their knowledge, their ideas, and numerous tips all of which culminated in the completion of this thesis. Dr. Partal was always with me during both Syracuse and Istanbul sections of my work. I would like to express my special gratitude and thanks to my advisors and Yildiz Technical University assistants for giving me such attention and time. I would like to extend my sincere thanks to all of them for development, fabrication, and the measurements of the filter. Finally, an honorable mention goes to my parents and my friends for their understandings and supports on me in completing this thesis. Special thanks to them, to my family and to my friends. I am grateful to everyone who was on my side during my master thesis.

I dedicate this thesis to my dad, my mom, and my one who is everything to me.

# Table of Contents

Acknowledgements.....	iv
Table of Contents.....	v
Index of Figures.....	vii
1. Introduction.....	1
1.1. Introduction to Ultra-Wideband.....	2
1.2. UWB RF Systems and Applications.....	4
2. UWB Filters.....	7
2.1. The Usage of UWB Filters.....	8
2.2. UWB Filter Studies.....	10
2.3. Filter Bandwidth Improvement Techniques.....	16
2.3.1. Tapped Input.....	16
2.3.2. Impedance Transformation.....	16
2.3.3. Low Dielectric Constant Material/Thicker Substrate.....	17
2.3.4. Multiline Couplers.....	17
2.3.5. Sufficient Number of Resonator Sections.....	18
2.3.6. Half Wavelength Separated Shorted Resonators.....	18

2.3.7. High Pass - Low Pass Filter Combination.....	19
2.3.8. Utilizing Defected Ground Structures (DGS) .....	20
3. Design and Development of an UWB Filter.....	21
3.1. Design Procedure.....	22
3.2. Design Specifications and Initial Filter Model.....	23
3.3. AWR Circuit Synthesis.....	24
3.4. Sonnet EM Simulation.....	27
3.5. CST EM Simulation.....	28
3.6. Co-Simulations.....	31
3.7. Final Prototype of the Filter.....	32
3.8. Tolerance Analysis.....	34
3.9. Fabrication & Measurements.....	36
3.10. Debugging and Final Filter Measurements.....	38
3.11. Further Development.....	40
4. Conclusion.....	42
References.....	44
Vita.....	46

## Index of Figures

1.1: FCC Frequency Mask for UWB Applications.....	3
1.2: Representation of UWB pulses.....	4
2.1: UWB system: (a) Transmitter, (b) Receiver, (c) Licensed and unlicensed band around the UWB spectrum, (d) FCC mask.....	9
2.2: Microstrip Line.....	10
2.3: Embedding high pass filter stubs into stepped impedance low pass filter: (a) Prototype, (b) Designed Filter Performance.....	11
2.4: Filter using Hybrid Microstrip DGS: (a) Prototype, (b) Filter Performance.....	12
2.5: Filter using Microstrip Stub-Loaded Dual-Mode Resonator Doublets: (a) Prototype, (b) Filter Performance.....	13
2.6: Filter using short circuited stubs: (a) Prototype, (b) Filter Performance.....	13
2.7: Filter using Parallel-Coupled Microstrip Lines: (a) Prototype, (b) Filter Performance.....	14
2.8: Filter with Wide Rejection Band using Defected Ground Structures: (a) Top-side view, (b) Bottom-side view, (c) Filter Performance.....	15
2.9: Tapped Input.....	16



2.10: Filter Sample with Tapped Input Section	
(remove coupled input section).....	16
2.11: Coupled Lines with impedance transforming section.....	17
2.12: Multiline coupled line filter sample.....	17
2.13: Quarter wavelength shorted stub separated by half wavelength lines.....	18
2.14: Sample filter with Shorted Stubs.....	18
2.15: Sample filter with Resonator Doublets.....	19
2.16: A Low Pass\High Pass cascaded UWB filter.....	19
2.17: Illustration of various DGS shapes.....	20
3.1: Flowchart of the design procedure.....	22
3.2: The structure of the shorted stub BPF.....	23
3.3: The design prototype of the filter.....	24
3.4: AWR optimized circuit schematic.....	25
3.5: AWR Layout.....	26
3.6: AWR Simulation Result.....	26
3.7: Sonnet EM Simulation.....	27
3.8: Sonnet EM Simulation Analysis Result.....	28

3.9: CST models of the filter.....	28
3.10: CST EM Simulation Analysis Result.....	29
3.11: S-Parameter Impedance View of the filter, using CST EM Simulation.....	29
3.12: E- Field View of the filter, using CST EM Simulation.....	30
3.13: Surface Current View of the filter, using CST EM Simulation.....	30
3.14: Final Schematic of the Filter, using AWR.....	32
3.15: Final Layout of the Filter, using AWR.....	32
3.16: Final AWR Simulation Result.....	33
3.17: Final CST Simulation Result.....	33
3.18: AWR Simulation Results for linewidth variations, (a) Nominal case, (b) linewidths +10%, (c) linewidths -10%.....	34
3.19: CST EM Simulation Results after decreasing the linewidths by %5.....	35
3.20: CST EM Simulation Results after increasing the linewidths by %5.....	35
3.21: Fabricated Filter.....	36
3.22: The measurement of the Filter Performance, using Network Analyzer.....	37
3.23: Measured S-Parameters of the Filter (a-before tuning, b-after tuning).....	37
3.24: AWR Simulation Results due to tolerance analysis (series lines' widths).....	38

3.25: The final view of the filter at the final measurement process.....	39
3.26: The final S-parameter measurements of the filter.....	40
3.27: Linelength analysis in simulation for further development.....	41

**CHAPTER 1**  
**INTRODUCTION**

# **1. Introduction**

## **1.1. Introduction to Ultra-Wideband**

Ultra-wideband systems use wireless technology capable of transmitting data over a wide spectrum of frequency bands for short distances with very low power and high data rates. They are used for the operation of sending and receiving extremely short bursts of RF energy. The UWB systems have outstanding ability for applications that require precision distance or positioning measurement as well as high-speed wireless connectivity.

The UWB technology delivers high data rates in excess of 100 Mbps up to 1 Gbps. The UWB waves can penetrate through doors and other obstacles. The key advantages of the UWB systems over narrowband systems are high data rate due to the large bandwidth, low equipment cost, low power, and immunity to multipath.

An UWB transceiver system includes a digital and a RF hardware. The RF hardware, that is basically a RF front end, includes a low noise amplifier (LNA), a microwave filter, an antenna, and matching components with the required bandwidth.

In this thesis, UWB microstrip filters used in an UWB RF front end modules are studied. Design challenges and performance improvement techniques to achieve a filter that complies with the FCC defined spectral mask for UWB systems are investigated.

In 2002, the Federal Communications Commission (FCC) approved the use of ultra-wide band (UWB) from 3.1 GHz to 10.6 GHz for commercial communication applications. According to the FCC indoor limit that is seen in Fig 1.1, the FCC Frequency Mask mainly requires the following rejection specs for an UWB filter design:

- -10 dB minimum rejection at 3.1 GHz
- -10 dB minimum rejection at 10.6 GHz

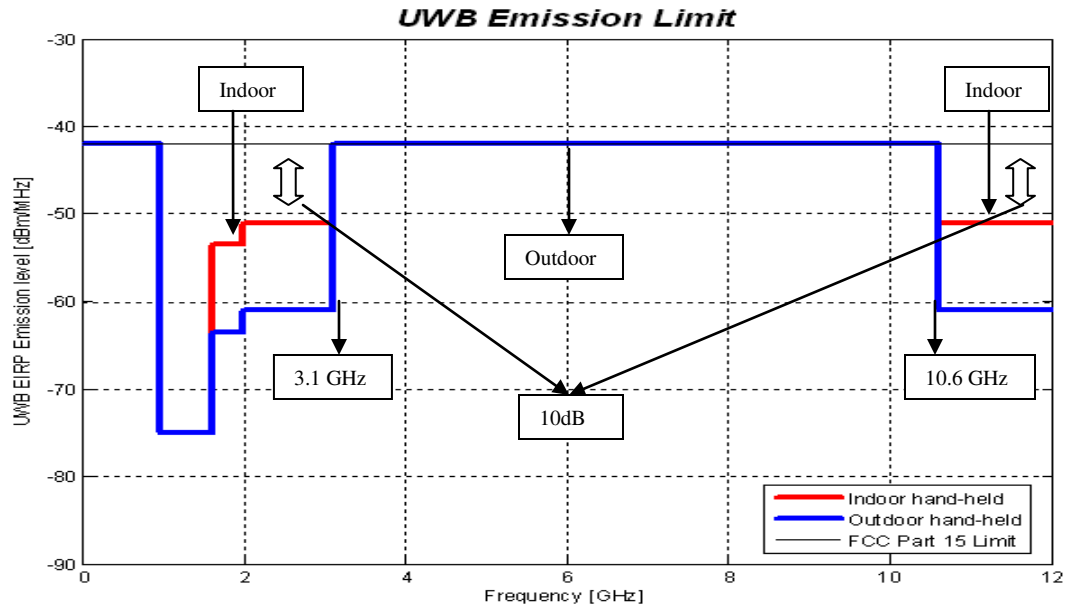

Figure 1.1: FCC Frequency Mask for UWB Applications

To build an ultra-wide band microstrip filter which meets the FCC specs shown in Fig. 1.1 is a challenging task for design engineers. Several approaches and structures have been reported to achieve the ultra-wide band performance in literature. A literature search and comparison study will be given further below.

## 1.2. UWB RF Systems and Applications

The UWB radios typically communicate with short pulses or cycles on the order of nanoseconds, spreading their energy over a wide swath of bandwidth, as opposed to modulated sinusoids whose energy is localized around a single frequency [1].

A sample pulse is shown in Fig.1.2 below. The impulse radio UWB transmits data based on the transmission of very short pulses with several Gigahertz bandwidths.

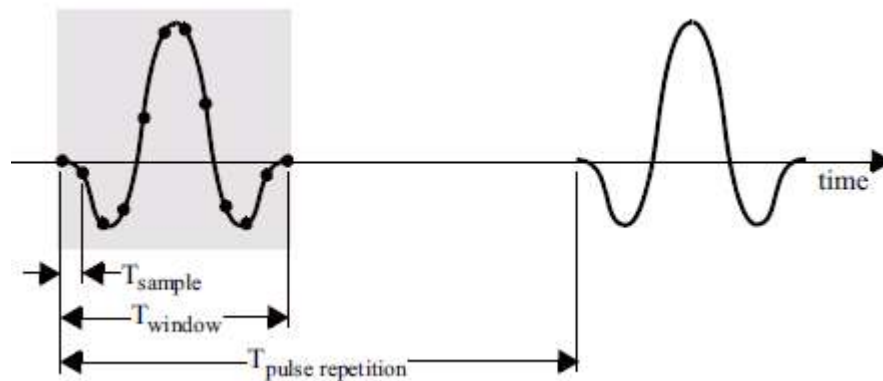

Figure 1.2: Representation of UWB pulses

UWB signaling has many attributes that make it attractive for a wide range of applications; from ultra-low-power RFID tags & wireless sensors to streaming wireless multimedia & wireless USB at a greater rate than 1Gb/s [2]. The high data rate multimedia home networks or child locator applications are a few to name.

The UWB is seen as the most efficient technology for short range wireless interconnection between computing devices. Many applications in wireless technology have been focused on narrowband implementations. Technology requirements on UWB systems present differences from the narrow band ones. However, silicon and hardware

improvements, challenges in software and algorithms for efficient data transmission and network management are the technical challenges that should be taken up by this new technology.

Ultra-wideband (UWB) technology essentially enables the following wireless communication systems:

- Short-range (*up to 10 m*), higher data-rates (*up to 1 Gbits/s*) applications such as the IEEE 802.15.3a (WPAN) standard operating at 3.1-10.6 GHz;
- Long-range (*up to 100m*), lower data rates (*up to 1 Mbits/s*), e.g. wireless sensor networks operating at frequencies below 960 MHz [3].

For a high level of deployment in short and long ranges, low cost, low power solutions are needed. Low operating frequency provides additional advantages of through-wall capability and lower circuit power consumption that makes UWB suitable for wireless sensor network in which battery life is a primary concern and line-of-sight (LOS) communication is preferred for ranging and positioning functionality [3].

Due to wideband requirements of the UWB transceiver's RF front-end, it is very challenging to design an RF front-end receiver with desired electrical specs. In most applications, it is desirable to obtain the following:

- wideband matching to a  $50 \Omega$  antenna and filter,
- good linearity,
- low power consumption,
- to gain flatness over the entire frequency range of interest is necessary to meet the design specifications.
- low noise



These properties are the cornerstones of the wideband receiver front-end which affect the total broadband communication system characteristics.

UWB technology modulates impulse based waveforms instead of continuous carrier waveforms. As explained above, the principles of UWB are extremely short pulses, and very low duty cycle at time domain. For frequency domain, ultra wide spectrum, low power spectral density, and acceptable interference with other users are main principles. Transferring higher data rate at very low power with higher bandwidth, it is not disturbed by normal RF. Also, it enables spectrum reuse as 3.1-10.6 GHz coexist with other users. The multipath immunity is in the form that path delay is much more greater than pulse width. The UWB system designs are almost all digital, simple analog modules that maintain low cost. UWB offers a solution for bandwidth, cost, physical size, and power consumption for next generation requirements.

UWB differs substantially from conventional narrowband radio frequency (RF) and spread spectrum technologies (SS), such as Bluetooth Technology and 802.11a/b/g. An UWB transmitter works by sending billions of pulses across a very wide spectrum of frequency several GHz in bandwidth. The corresponding receiver then translates the pulses into data by listening for a familiar pulse sequence sent by the transmitter. UWB's combination of larger spectrum, lower power and pulsed data improves speed and reduces interference with other wireless spectra [4].

Based on FCC's regulations the UWB radio transmissions can legally operate in the range from 3.1 GHz up to 10.6 GHz, at a limited transmit power of  $-41\text{dBm/MHz}$ . The result is short-range channel capacity and limited interference, but the UWB provides dramatic channel capacity at short range that limits interference.

**CHAPTER 2**  
**UWB FILTERS**

## **2. UWB Filters**

### **2.1. The Usage of UWB Filters**

Transmitter and receiver block diagrams of an RF front end, licensed and unlicensed bands along with the FCC mask are shown in Fig.2.1. A RF front end essentially consists of a low noise amplifier, a filter, and an antenna. This thesis focuses on design of the UWB microstrip filter which can be employed in this UWB RF front end module.

To transmit or receive a high-quality signal, an UWB bandpass filter must have the following specifications:

- Typical bandwidth of 20% or 500 MHz or greater
- A high selectivity to reject signals from existing systems such as 1.6 GHz global positioning systems (GPS), 1.9 GHz cellular band, and 2.4 GHz ISM band operating systems.

In the recent decade, the UWB systems have been developed and applied widely. In order to meet the FCC specifications, a good selectivity at both lower and higher frequency ends and flat group-delay response over the whole band are required.

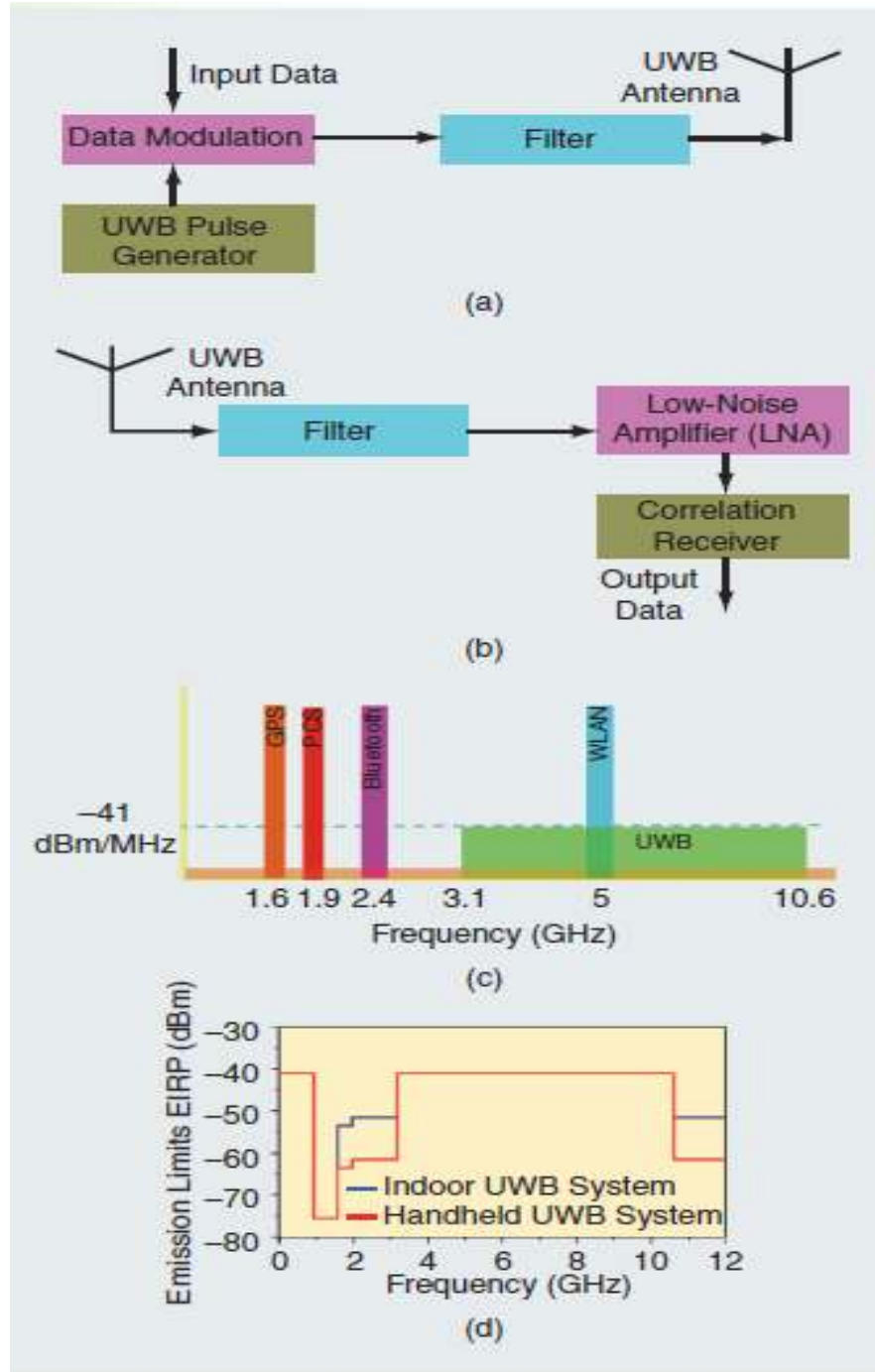

Figure 2.1: UWB system: (a) Transmitter, (b) Receiver, (c) Licensed and unlicensed band around the UWB spectrum, (d) FCC mask

## 2.2. UWB Filter Studies

Various methods and structures are studied to develop the UWB filters. Since this thesis focuses on microstrip line technology (Fig.2.2), a list of some of the UWB microstrip line filter studies are given below.

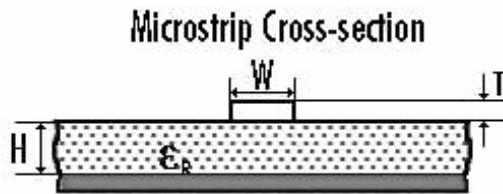

Figure 2.2: Microstrip Line

*i. Combined High Pass / Low Pass Microstripline UWB Filters:*

The design, studied in [5], shown in Fig. 2.3, proposes embedding of individually designed highpass structures and lowpass filters (LPF) into each other, then optimizing for a good in-band performance. The stepped-impedance transmission line sections are employed to attenuate the upper stopband and quarter-wave short-circuited stubs are used to realize the lower stopband [5].

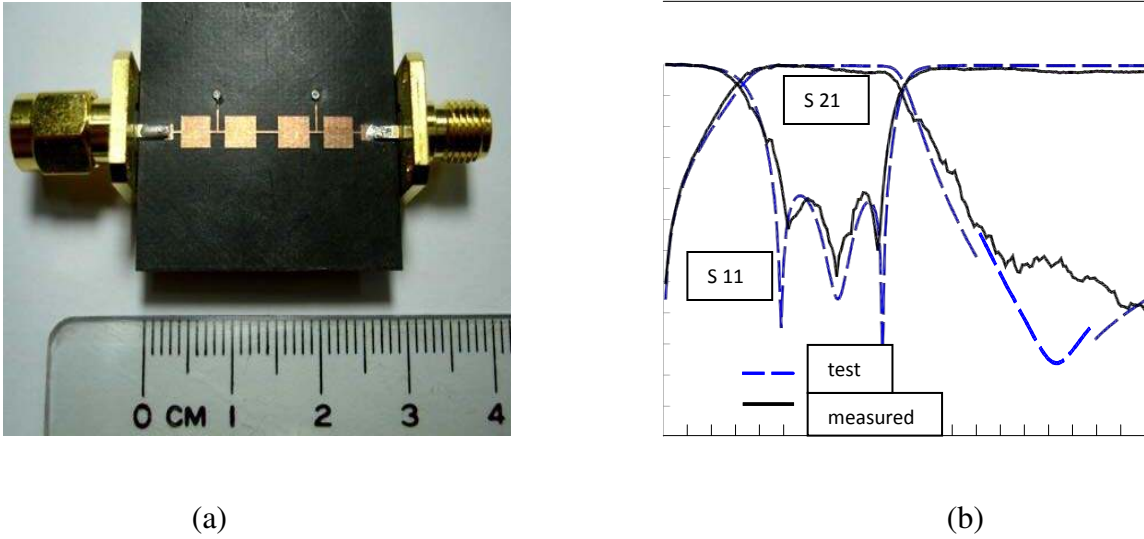
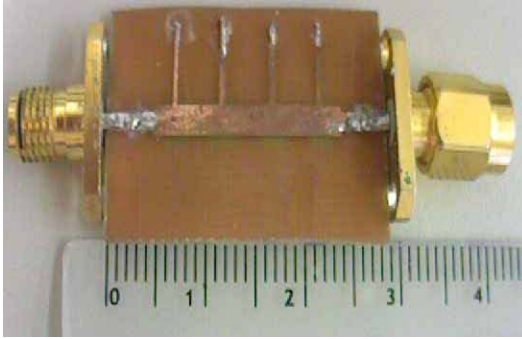

Figure 2.3: Embedding high pass filter stubs into stepped impedance low pass filter:

(a) Prototype, (b) Designed Filter Performance

ii. *Ultra-Wideband Bandpass Filter Using Hybrid Microstrip-Defected-Ground Structures:*

The proposed filter, studied in [6] and shown in Fig. 2.4 was designed using a combination of hybrid microstrip-defected-ground structure lowpass filter (LPF) with typical quarter-wavelength short-circuited stubs highpass filter (HPF), followed by an optimization for tuning in-band performance. The filter comes with a good performance, including an ultra-wideband bandpass (3.1-10.6 GHz), low insertion loss, sharp rejection, flat group delay, high selectivity, and excellent performance outside of the bandpass [6].



(a)

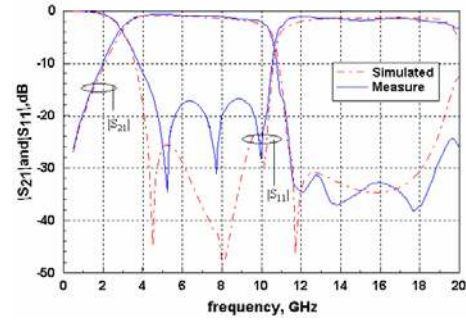

(b)

Figure 2.4: Filter using Hybrid Microstrip DGS: (a) Prototype, (b) Filter Performance

iii. *A Novel Compact Ultra-Wideband Bandpass Filter Using Microstrip Stub-Loaded Dual-Mode Resonator Doublets:*

A novel compact ultra-wideband (UWB) bandpass filter, studied in [7], given in Fig. 2.5 is developed by using microstrip stub-loaded dual-mode resonator doublets. The proposed doublet consists of two parallel but oppositely arranged stub-loaded resonators, and has a significantly widened passband. The filter has a passband covering 3.3-10.4 GHz, and exhibits sharp attenuations near its passband [7]. The measured frequency response of the filter has a good agreement with the designed one, and the FCC's indoor limit is satisfied quite well.

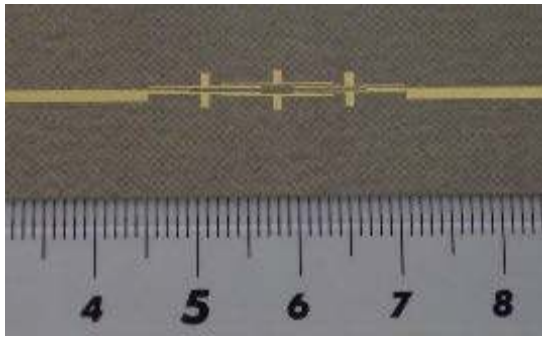

(a)

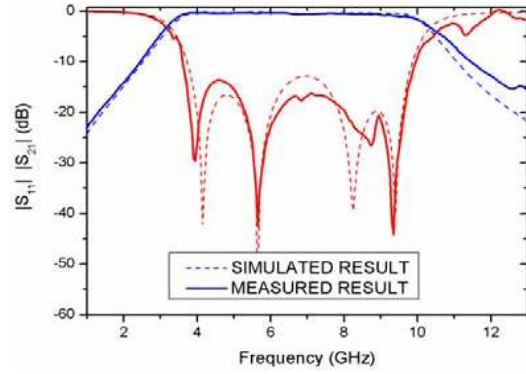

(b)

Figure 2.5: Filter using Microstrip Stub-Loaded Dual-Mode Resonator Doublets:

(a) Prototype, (b) Filter Performance

iv. *Ultra-wide microstrip band pass filter using short circuited stubs:*

A novel ultra-wideband microstrip filter, studied in [8], given in Fig.2.6 is proposed and physically implemented. The band pass filter is designed by employing short-circuited stubs with etched rectangular lattice. Here, the etching provides a better return loss. Similar studies with quarter-wavelength short-circuited stubs are published in providing wideband filter characteristics [9].

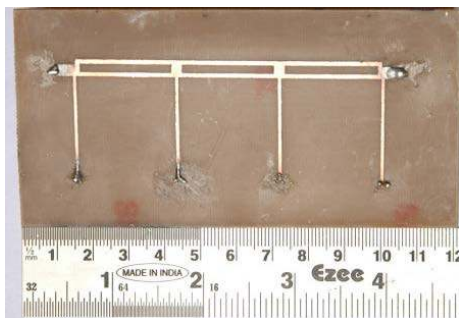

(a) (b)

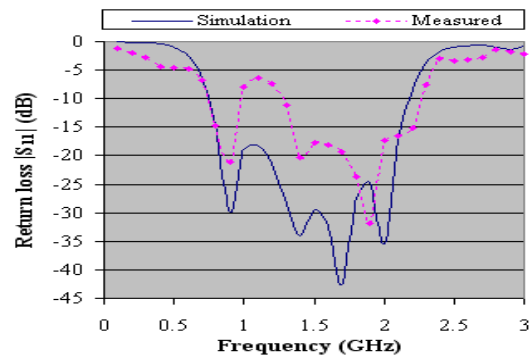
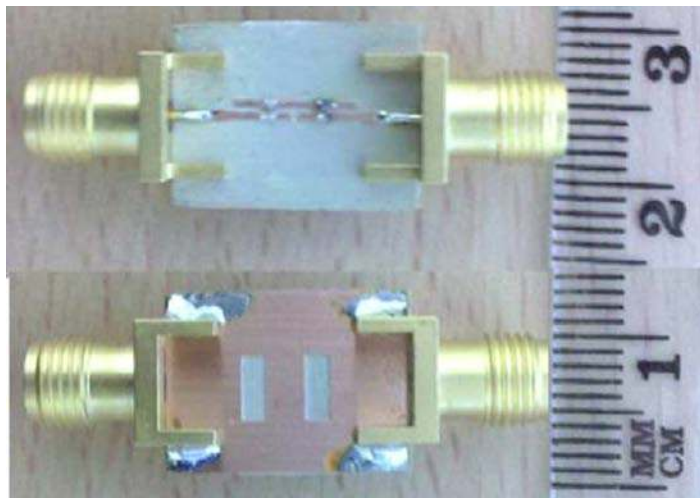

Figure 2.6: Filter using short circuited stubs: (a) Prototype, (b) Filter Performance



v. *Design Method for Ultra-Wideband Bandpass Filter with wide Stopband Using Parallel-Coupled Microstrip Lines:*

The structure studied in [10], given in Fig. 2.7 is composed of a stepped-impedance parallel-coupled microstripline structure. A theoretical model is derived and used to find the optimum length and coupling factor for each of those subsections for an UWB passband and suppressed second and third harmonic responses in the stopband.



(a)

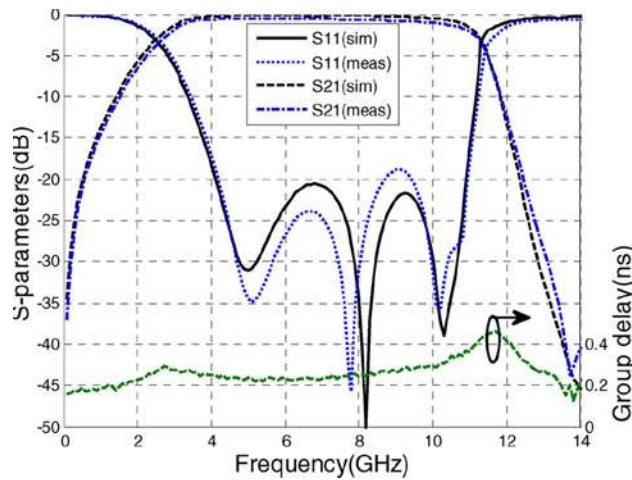

(b)

Figure 2.7: Filter using Parallel-Coupled Microstrip Lines:  
(a) Prototype, (b) Filter Performance

vi. *An UWB High-Q Bandpass Filter with Wide Rejection Band using Defected Ground Structures:*

In this study, an ultra-wideband microstrip bandpass filter (BPF) operating from 2 GHz to 4.7 GHz, with high selectivity and wide rejection band is presented and experimentally verified (see [11], and Fig.2.8). The filter is composed of microstrip lines with shorted stubs acting as a high pass filter (HPF) on top side and dumbbell shaped defected ground structures (DGSs) on bottom side acting as a bandstop filter (BSF). The seventh order high pass filter structures and three dumbbell shaped DGS resonators combined on a single layer microstrip substrate are optimized using microwave circuit and electromagnetic (EM) simulation tools to obtain the ultra-wideband bandpass filter.

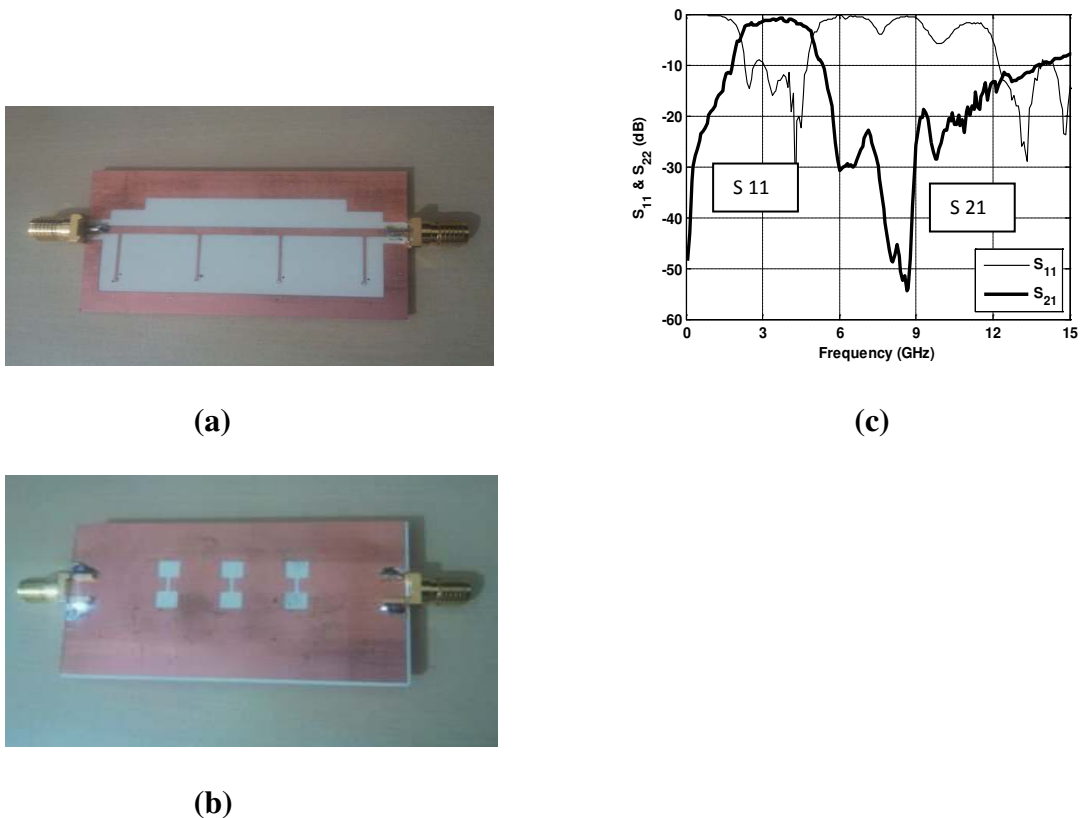

Figure 2.8: Filter with Wide Rejection Band using Defected Ground Structures: (a) Top-side view, (b) Bottom-side view, (c) Filter Performance

## 2.3. Filter Bandwidth Improvement Techniques

### 2.3.1. Tapped Input

Wide band coupled line filters usually require a tight coupling at the input and output coupled line sections. The tight coupling is usually not realizable for most microstrip line filters. Tapping the input and output of a coupled line filter gives an opportunity to remove the tightly coupled first and last coupler sections. See Figs. 2.9 and 2.10.

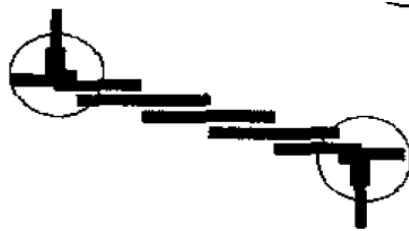

Figure 2.9: Tapped Input

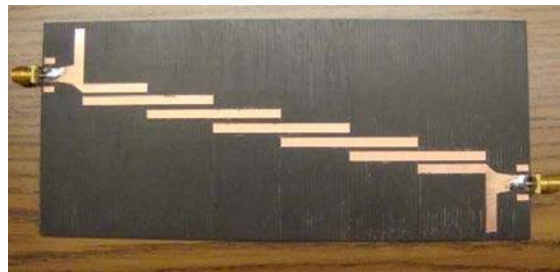

Figure 2.10: Filter sample with tapped input section (removed coupled input section)

### 2.3.2. Impedance Transformation

A proper impedance transformation at input / output of a coupled line filter improves the bandwidth of the transmission lines [12] as shown in Fig 2.11.

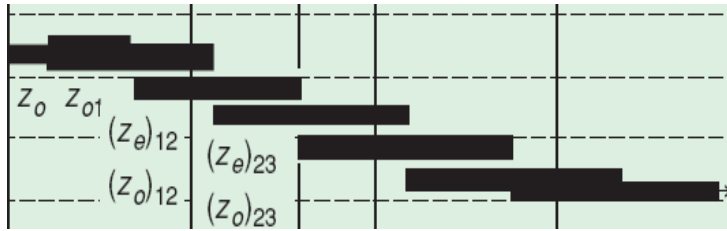

Figure 2.11: Coupled Lines with impedance transforming section

### 2.3.3. Low Dielectric Constant Material / thicker substrate

Using low dielectric constant substrate or thicker substrate makes the high impedance lines possible to realize and eliminate very narrow lines. This also results in wider and realizable coupler gaps.

### 2.3.4. Multiline Couplers

Utilizing multiline coupled lines contributes increasing the coupled energy which gives higher coupling ratio. Each line section adds up the energy making a higher coupling and higher bandwidth possible [13].

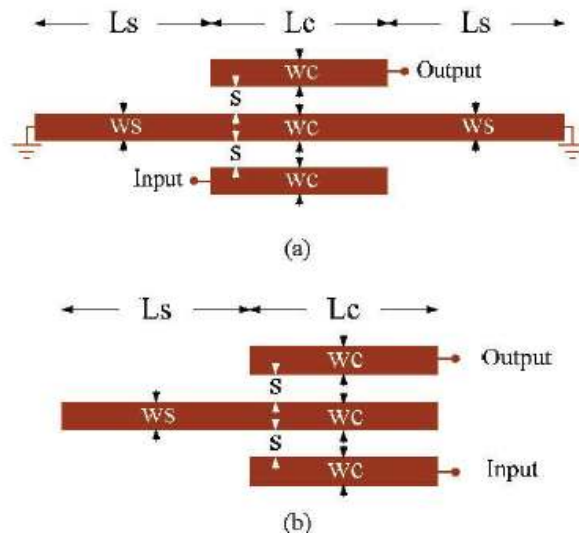

Figure 2.12: Multiline coupled line filter sample

### 2.3.5. Sufficient number of resonator sections

In order to obtain wide bandwidth, a sufficient resonator sections must be employed. The resonator parameters are calculated by following well known polynomial equations such as Chebyshev, Butterworth, Elliptical types.

### 2.3.6. Half Wavelength Separated Shorted Resonators

Quarter wave short stubs separated with half wavelength inverters provide a very wide bandwidth (Figs 2.13 – 2.15) [7]-[8].

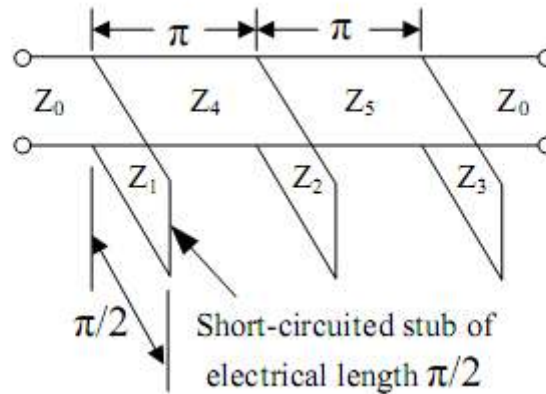

Figure 2.13: Quarter wavelength shorted stub separated by half wavelength lines

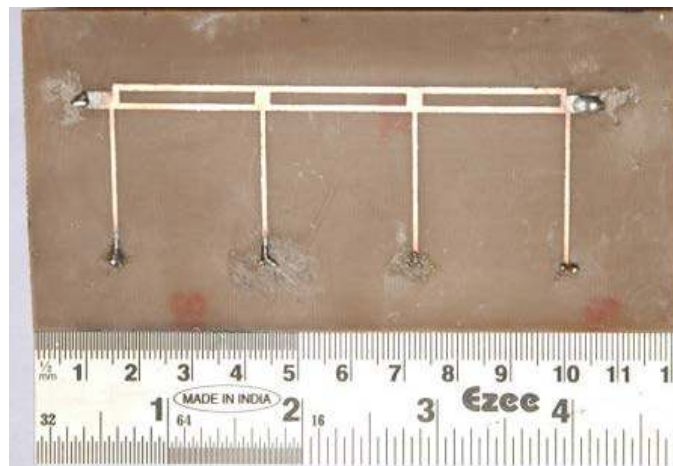

Figure 2.14: Sample filter with Shorted Stubs

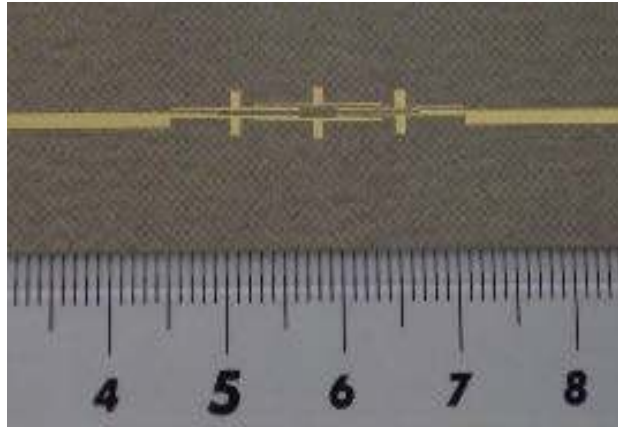

Figure 2.15: Sample filter with Resonator Doublets

### 2.3.7. High Pass - Low Pass Filter Combination

Combining and cascading high pass and low pass filters conveniently, as shown in Fig.2.16, give a good solution for a wideband performance [5]. The new combined filter behave like one band pass filter with greater bandwidth.

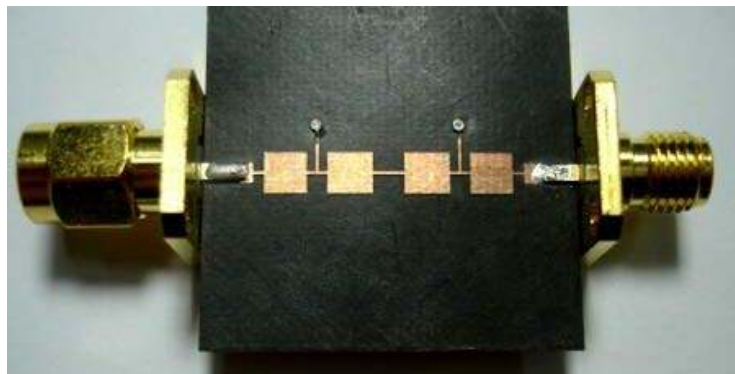

Figure 2.16: UWB filter with A Low Pass / High Pass filter combination

### 2.3.8. Utilizing Defected Ground Structures (DGS)

One of the design techniques for obtaining high performance microwave filters is using defected ground structure resonators which are typically etched as various shaped breaks in the ground plane. DGSs act as parallel L-C resonators which resonate at certain frequencies depending on their dimensions and shapes. Fig.2.17 shows some DGS shapes given in [14].

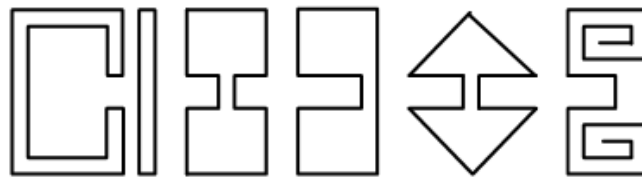

Figure 2.17: Illustration of various DGS shapes

## **CHAPTER 3**

### **DESIGN AND DEVELOPMENT OF AN UWB FILTER**



### 3. Design and Development of an UWB Filter

In this section, a sample ultra-wideband microstrip filter design and development is presented. Filter details including circuit model, simulations, optimizations, layout creation, manufacturing, testing and troubleshooting are explained.

#### 3.1. Design Procedure

The essential design flow in this study is given in Fig. 3.1.

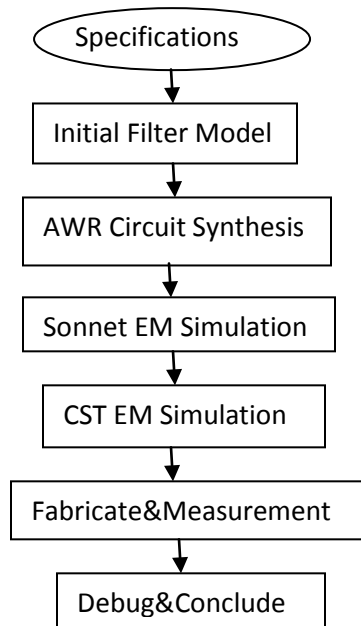

Figure 3.1: Flowchart of the design procedure

The UWB filter design in this study starts with an ideal model composed of quarter wavelength shorted stubs separated with half wavelength inverters. This topology has been adopted for its simple structure. The structure of the shorted stub band pass filter (BPF) is seen in Fig 3.2.

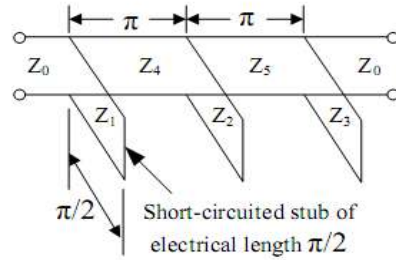

Figure 3.2: The structure of the shorted stub BPF

After determining the prototype and specifications for the filter, the circuit simulation optimizations are done by using AWR Microwave Office. EM Simulation is followed the circuit simulation. Sonnet EM Simulation and CST EM Simulation Tools are used for the EM Simulation to have accurate results with a good comparison performance. A tolerance analysis is also done using the simulation tools.

Then filter layout is generated and fabricated using an LPKF ProtoMat circuit milling machine. Filter response is measured using a vector network analyzer (VNA). Once it is observed that the filter basically is functioning near the specifications, a minor troubleshooting is applied to tune the filter. The final VNA measurement results are given at the end.

### 3.2. Design Specifications and Initial Filter Model

In this thesis, design and manufacturing of an ultra-wideband microstrip line filter covering the full 3.1-10.6 GHz band is considered. The ideal electrical model for the filter is based on half wavelength separated shorted stub resonators using distributed microstrip lines.

The design specifications for this UWB filter as as follows:

- -10 dB rejection at 3.1 GHz
- -10 dB rejection at 10.6 GHz
- Insertion Loss < 4 dB within the 3.6-10.1 GHz band
- Return Loss better than -10 dB within the band

The electrical design prototype of the filter is shown in Fig.3.3.

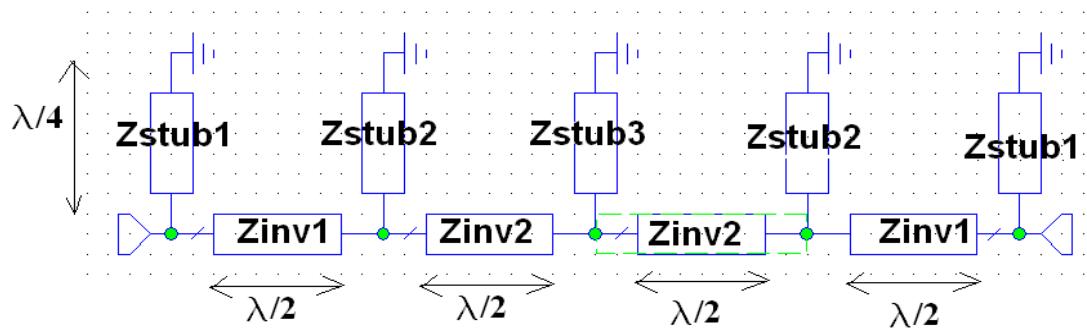

Figure 3.3: The design prototype of the filter

### 3.3. AWR Circuit Synthesis

The initial filter prototype is modeled in AWR for circuit simulations, as seen as in Fig. 3.4.

Rogers 6006 (RO6006,  $\epsilon_r= 6.15$ ,  $h=50$  mils,  $\tan\delta= 0.0027$ ) substrate is used to realize this design. The design is symmetrically generated as there are 6 horizontal thru transmission lines, and 5 vertical transmission lines where the first and last thru lines are actually the input and output lines. So, 4 thru lines in the middle and the other 5 vertical lines are symmetric within each group. Shorting cylindrical vias at the ends of the stubs are modeled conveniently in the simulation tool. The diameters of the vias are selected to be the same as the width of the narrowest vertical line.

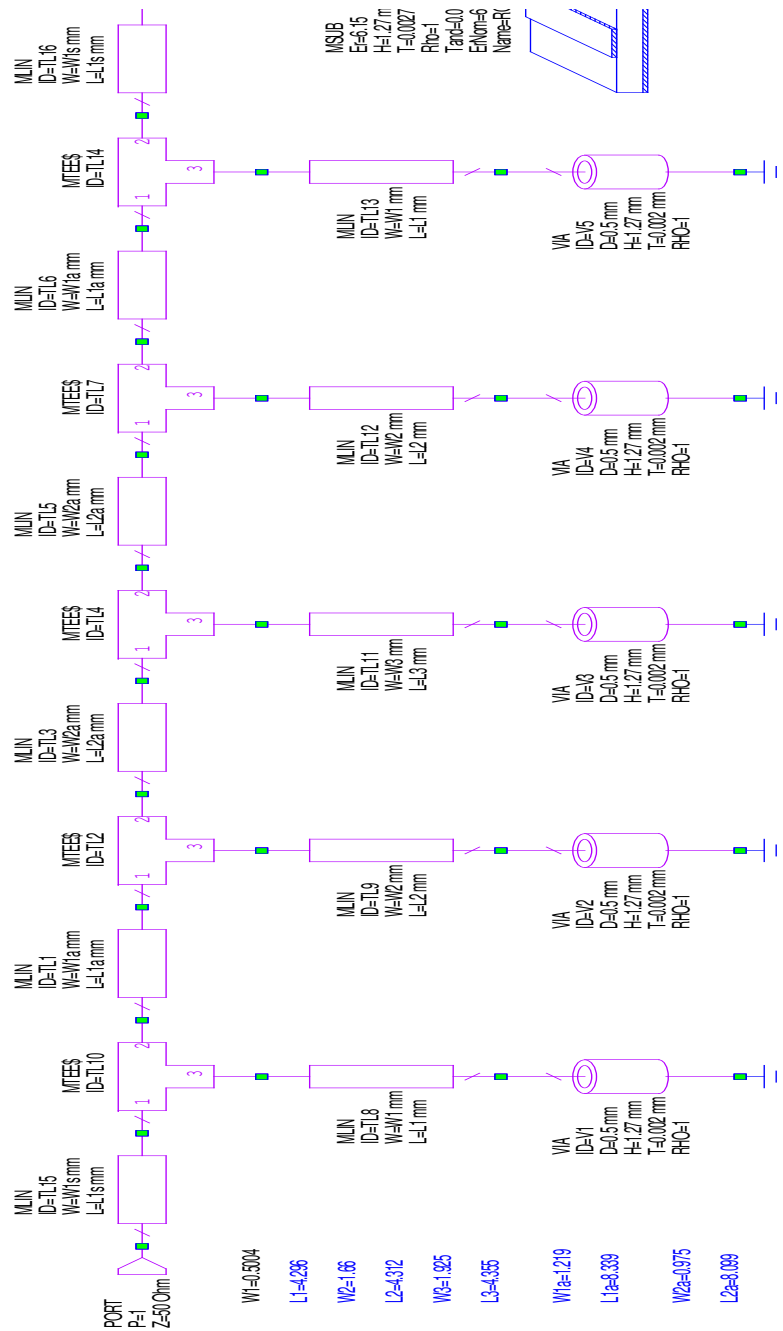

Figure 3.4: Initial AWR optimized circuit schematic

AWR Layout and AWR Simulation Result are given in Figs. 3.5 and 3.6.

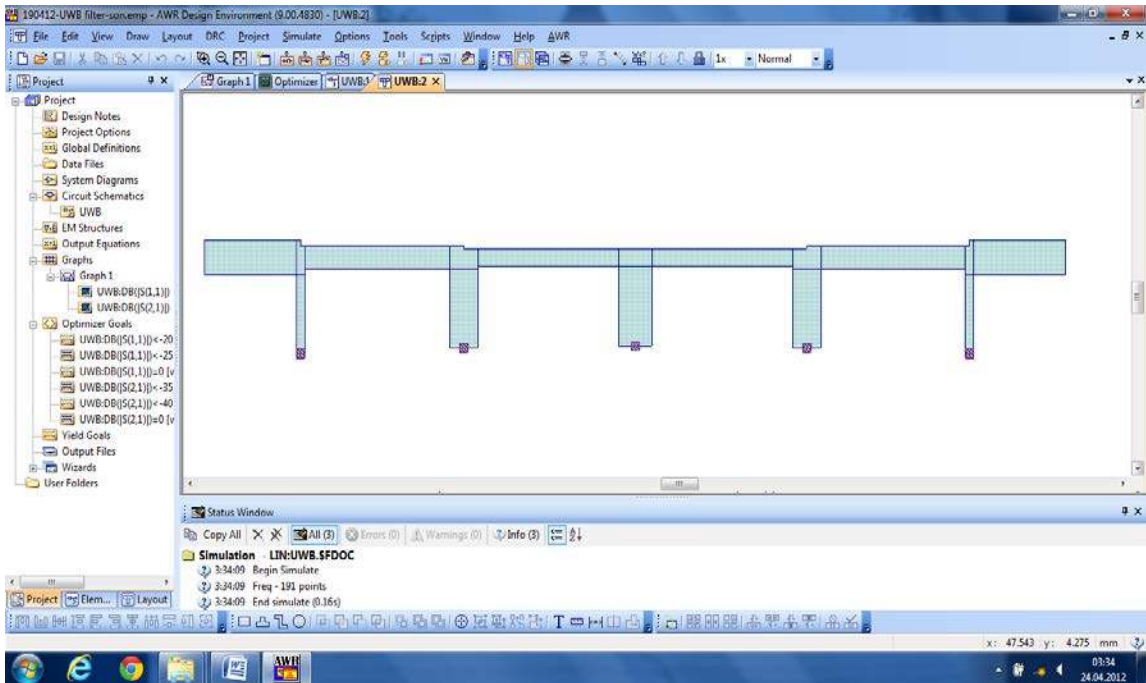

Figure 3.5: AWR Layout

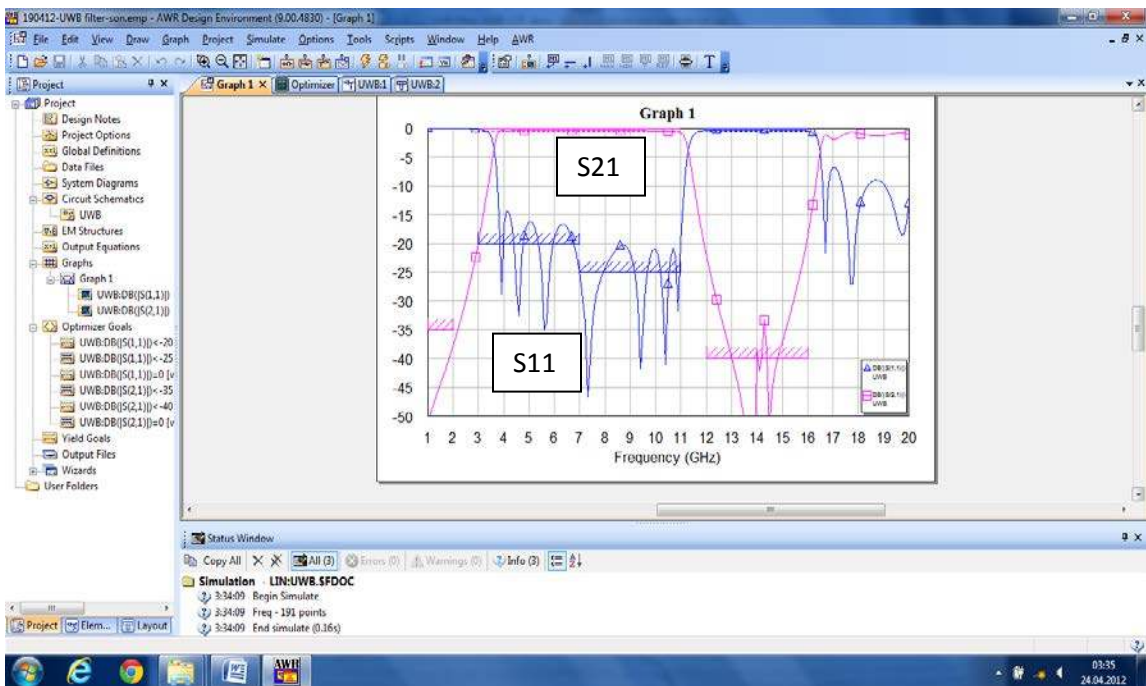

Figure 3.6: Optimized AWR Simulation Result

### 3.4. Sonnet EM Simulation

The circuit simulations are usually not powerful to obtain accurate results. In order to predict the filter response more accurately, simulations must also be performed using one or two EM simulation tools.

Therefore, after creating the layout for the filter at AWR, the .dxf file of the layout was imported into Sonnet EM Simulation. The material, filter box, and frequency range, etc are specified and the simulation setup is done. The Sonnet layout and analysis results are given in Figs. 3.7, and 3.8.

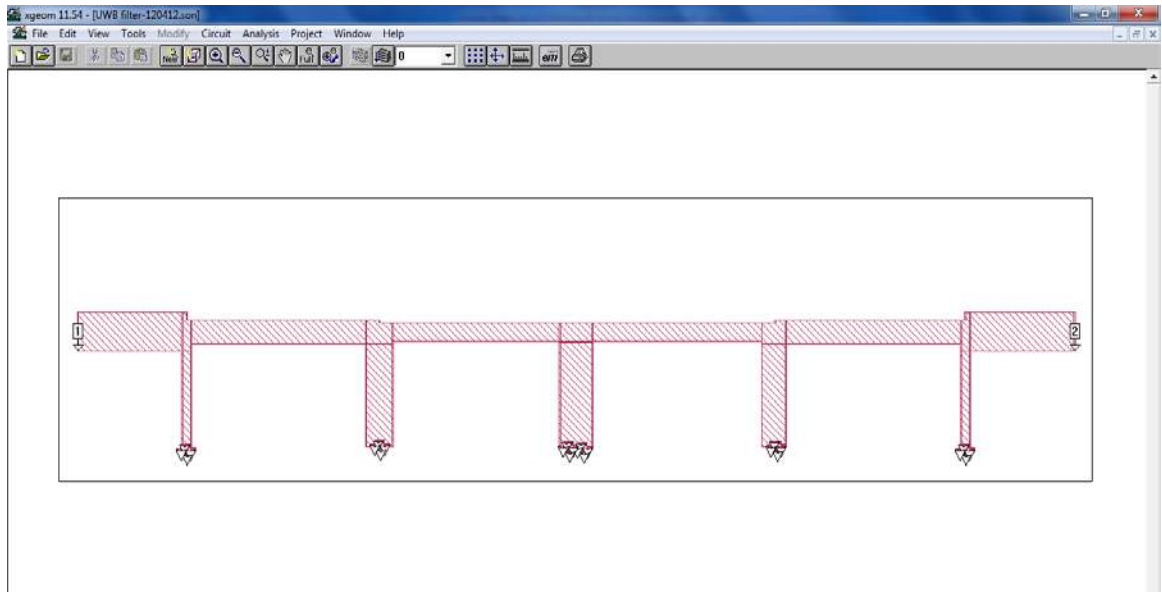

Figure 3.7: Sonnet Layout

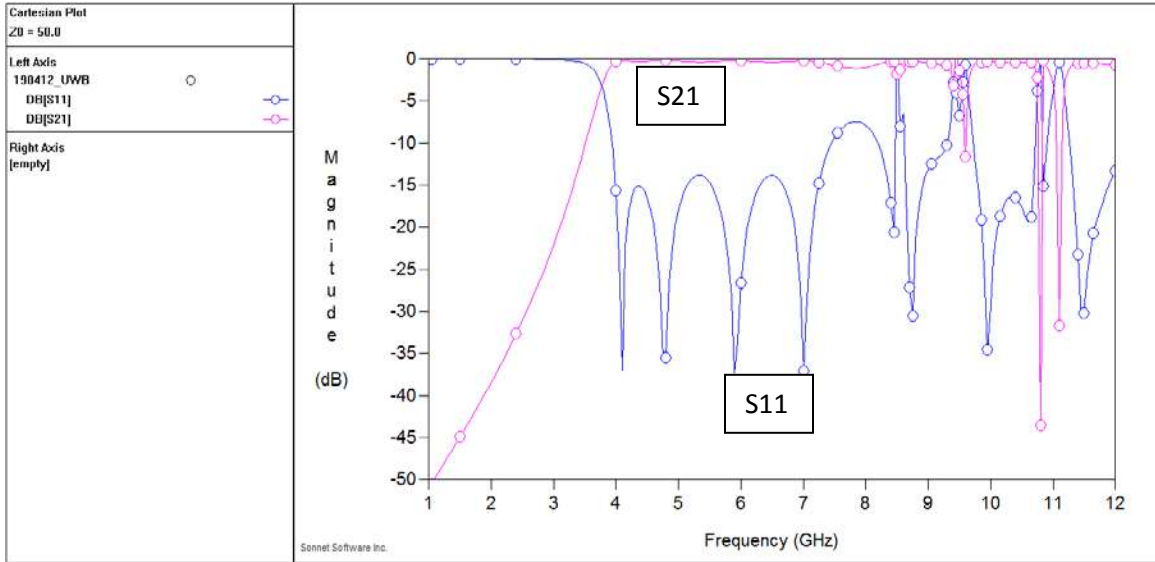

Figure 3.8: Sonnet EM Simulation Analysis Result

### 3.5. CST EM Simulation

After observing the AWR circuit and Sonnet EM Simulation results, a CST EM simulation is also performed.

In CST model, shorted stubs are terminated by drawing cylindrical vias from top transmission lines down to the ground plane in EM simulation tool.

The models of the filter using CST EM Simulation Tool are given in Fig. 3.9;

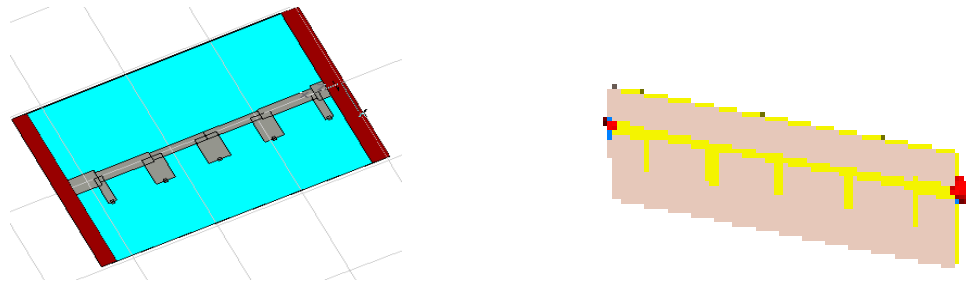

Figure 3.9: CST models of the filter

The CST EM Simulation results for the filter are given in Figs. 3.10, 3.11, 3.12. The EM simulations give the current distribution which is useful for understanding the signal behavior which helps the optimization process better. The current distribution plot is given in Fig. 3.13.

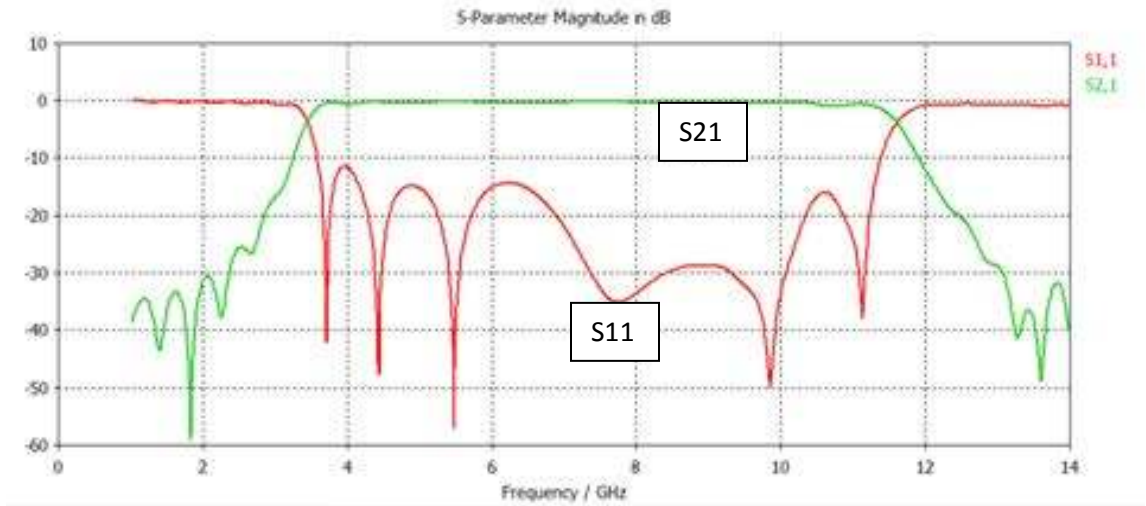

Figure 3.10: CST EM Simulation Analysis Result

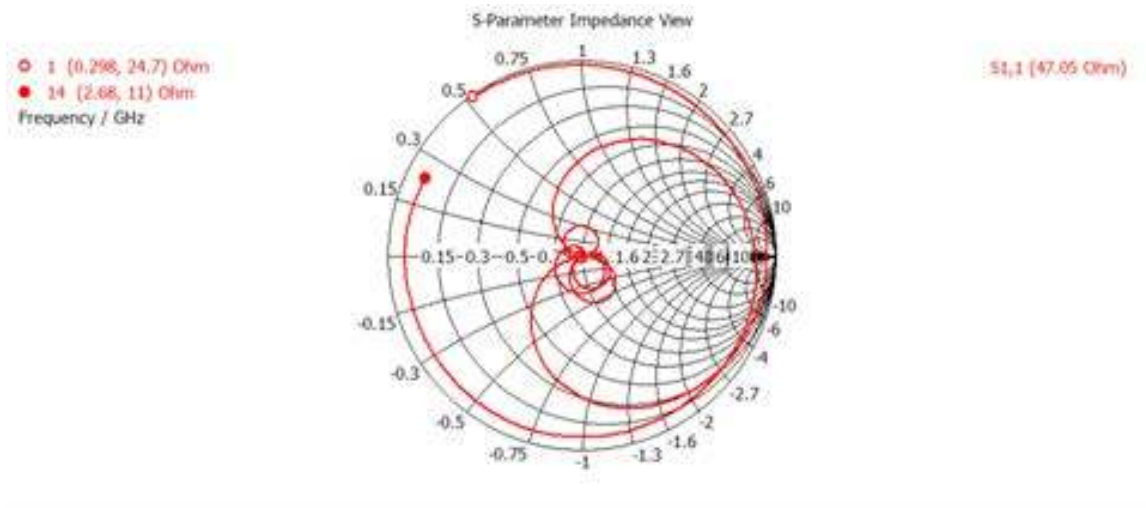

Figure 3.11: S-Parameter Impedance View of the filter,using CST EM Simulation



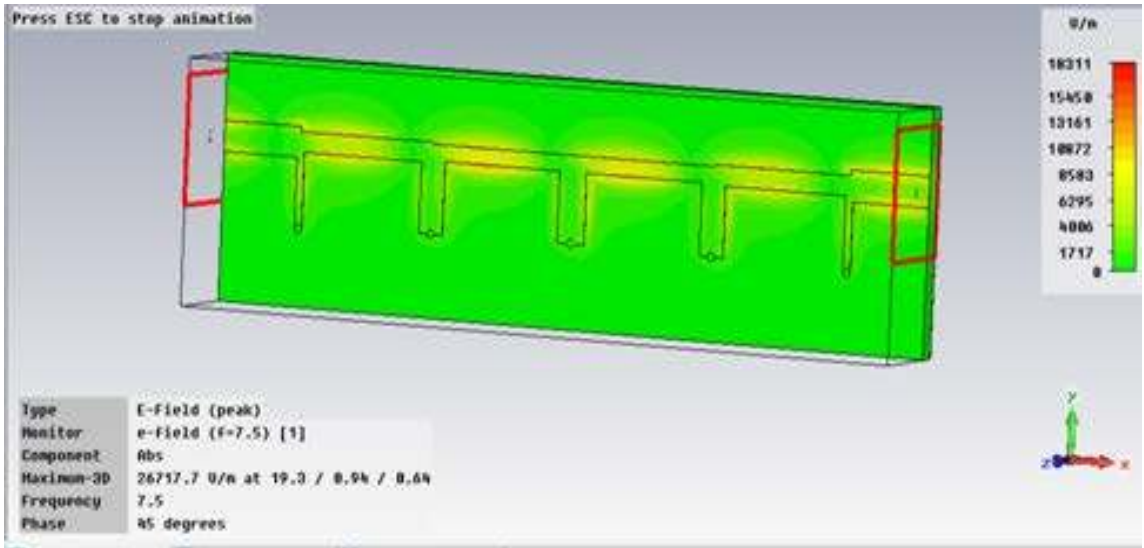

Figure 3.12: E- Field View of the filter, using CST EM Simulation

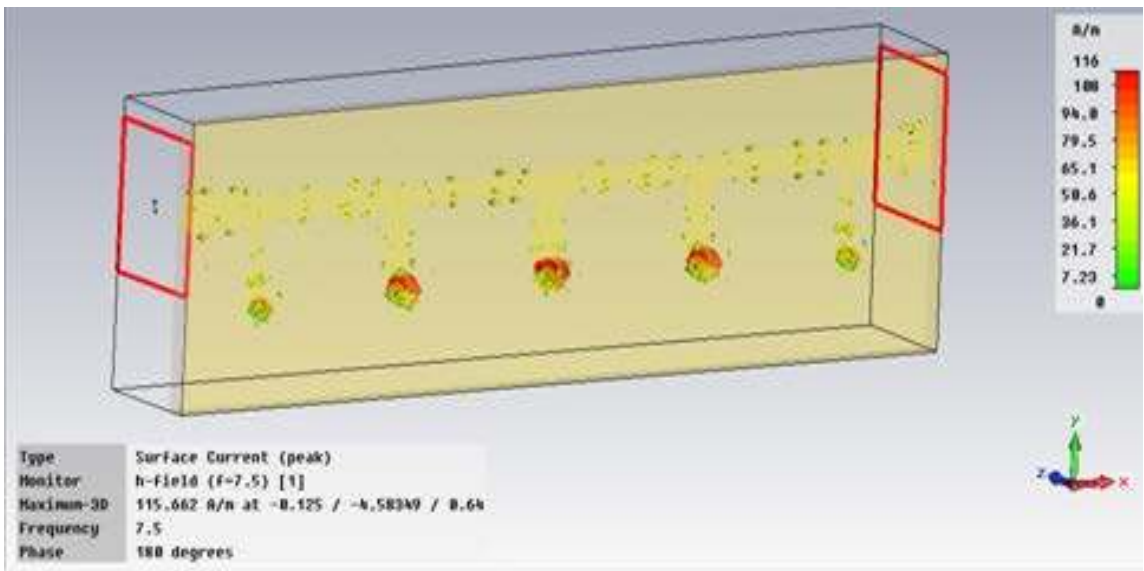

Figure 3.13: Surface Current View of the filter, using CST EM Simulation

### **3.6. Co-Simulations**

The EM Simulation is based on numerical solutions. Instead of simulation of individual components and analyzing an ideal circuit behavior, a physical structure simulation for the whole circuit is preferred. There are several non-ideal effects which affects the circuit performance. Adjacent components' coupling effects, wall/cover effects, end effects, step or junction discontinuities, etc, change the ideal circuit performance.

On the other hand EM simulations take long time due to numerical modeling and dense meshing. In order to perform an efficient and faster optimization, simulations in circuit and EM simulation tools should be analyzed and run together. After scrutinizing the EM simulation results; errors, band shifts and bandwidths are defined. Instead of iterative optimizations in an EM tool, the circuit simulation model is modified based on the defined error parameters. For instance, if there is shrinkage in frequency band in EM simulation results, the circuit simulation model is modified to compensate this shrinkage first. Then, regenerating the new modified layout is simulated in the EM simulation tool. This cycle must continue until the desired response is obtained in the EM tool.

Furthermore, plotting the current distribution on a circuit provides important information for the RF signal behavior. This is another feature of the EM simulation tool which helps speeding up the optimization.

In our example, this type of co-simulation scenario was applied to achieve the filter design goal and to obtain the final prototype.

### 3.7. Final Prototype of the Filter

As explained above, AWR, Sonnet, and CST Simulation Tools are used efficiently in order to observe the best performance for the filter. Final filter schematic, layout, and simulation results are given in Figs. 3.14, 3.15, 3.16, and 3.17.

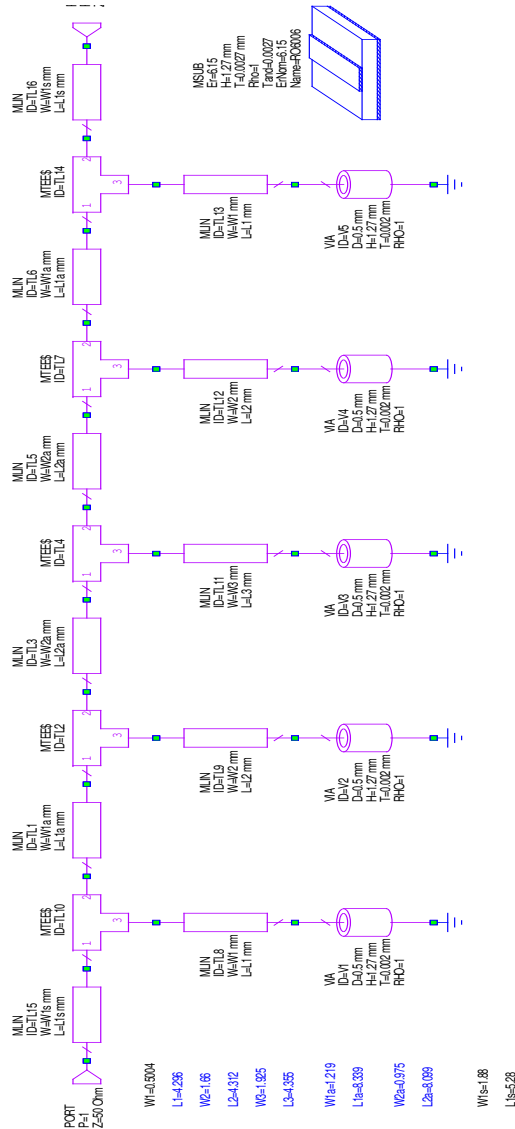

Figure 3.14: Final Schematic of the Filter, using AWR

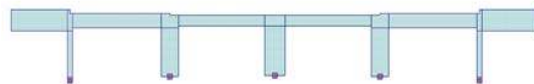

Figure 3.15: Final Layout of the Filter, using AWR

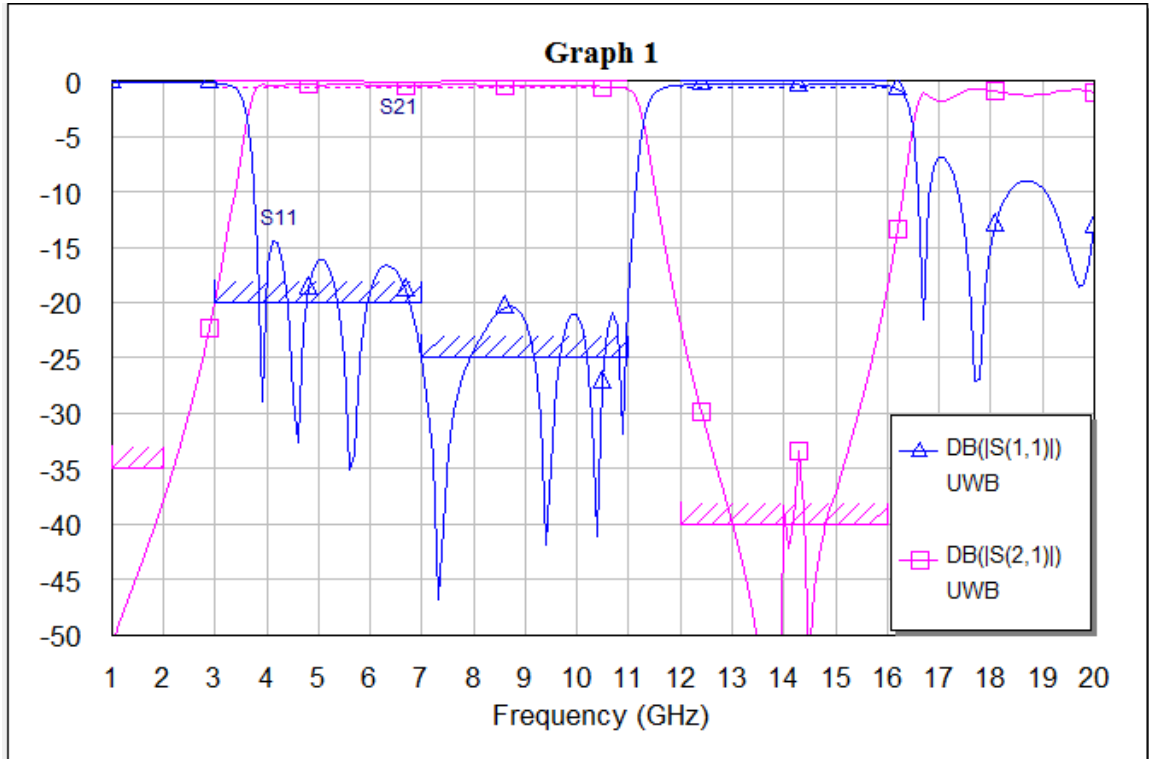

Figure 3.16: Final AWR Simulation Result

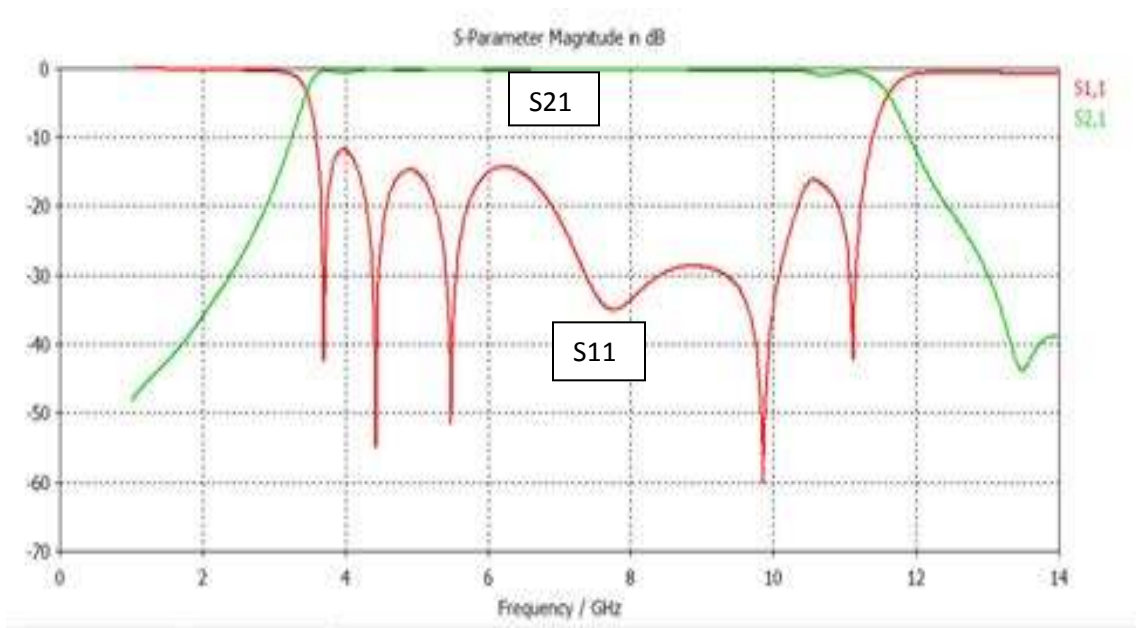
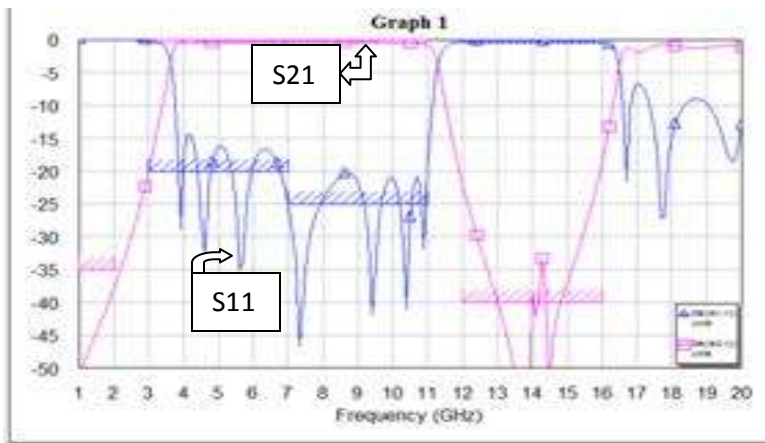

Figure 3.17: Final CST Simulation Result

### 3.8. Tolerance Analysis

A tolerance analysis study was performed by varying the linewidths of the lines. This will mainly help understanding the circuit behavior with wider or narrower lines. It is also important to understand the sensitivity of the circuit to machining tolerances.

The AWR Simulation results are shown in Fig. 3.18.



(a)

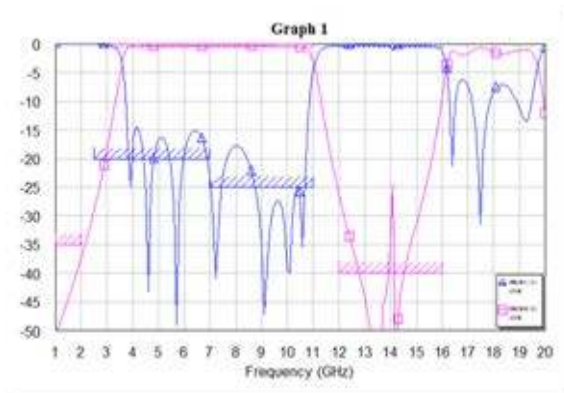

(b)

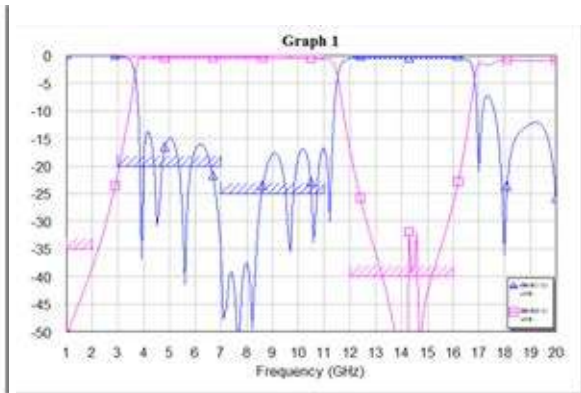

(c)

Figure 3.18: AWR Simulation Results for linewidth variations, (a) Nominal case, (b) linewidths +10%, (c) linewidths -10%.

In Fig. 3.18, a linewidth tolerance analysis results are shown. The linewidths are varied by  $\pm 10\%$  and compared with the nominal case. It is seen that our filter response may degrade minorly by manufacturing tolerances.

In CST EM Simulation Tool, all the linewidths are recalculated and regiven to the simulation analysis tool. CST EM Simulation results are given in Figs. 3.19 and 3.20.

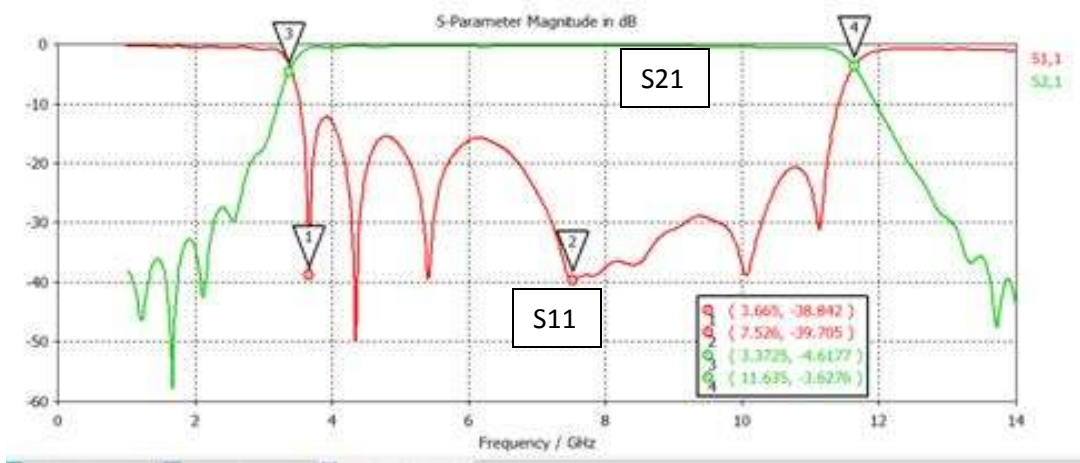

Figure 3.19: CST EM Simulation Results after decreasing the linewidths by %5

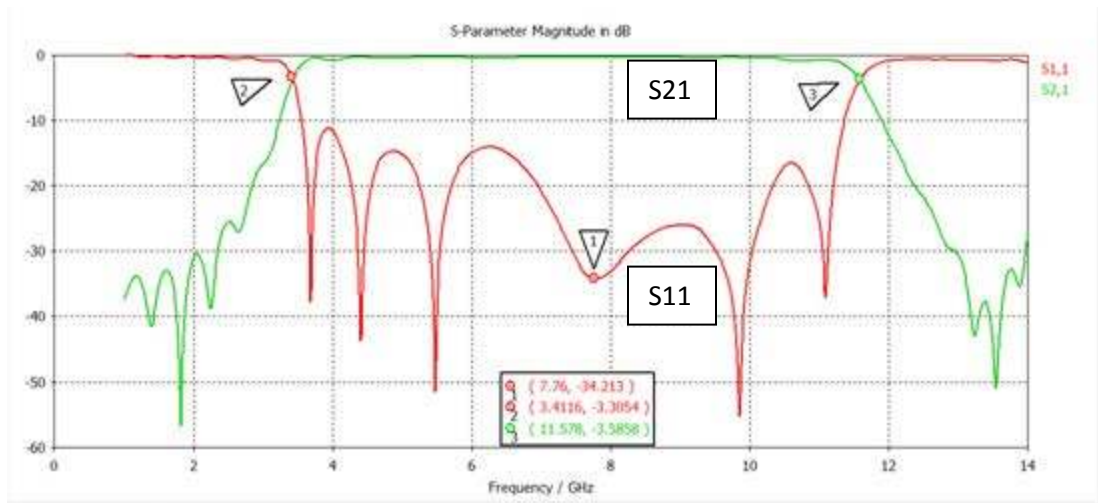

Figure 3.20: CST EM Simulation Results after increasing the linewidths by 5%

### 3.9. Fabrication & Measurements

The .dxf layout file is taken to LPKF's software configure for the milling and fabrication processes. After checking all dimensions and final adjustments, the fabrication was done by using LPKF milling machine (LPKF ProtoMat S63). After milling and drilling and plating processes, the filter is completed by adding the test port SMA connectors for measurements. The dimensions of the fabricated filter are 2 inch x 0.31 inch. The fabricated filter is shown below in Fig. 3.21.

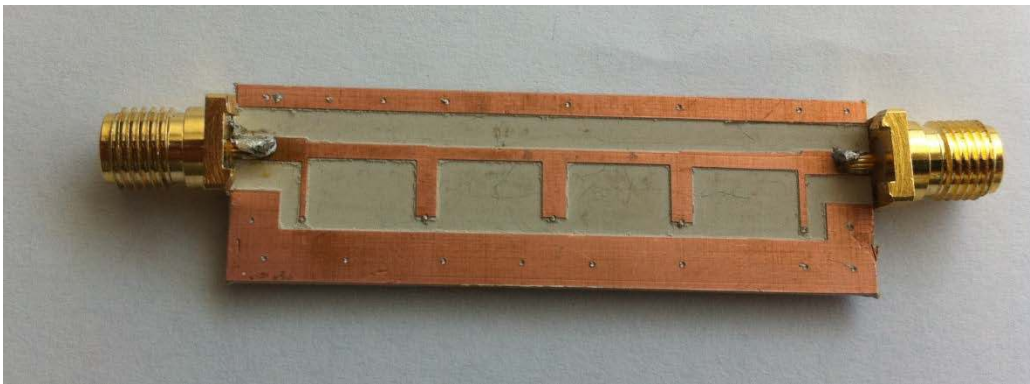

Figure 3.21: Fabricated Filter



After the fabrication process, the filter performance is measured by using Rohde & Schwarz ZVL Network Analyzer. The network analyzer is first calibrated for the operating frequency range.

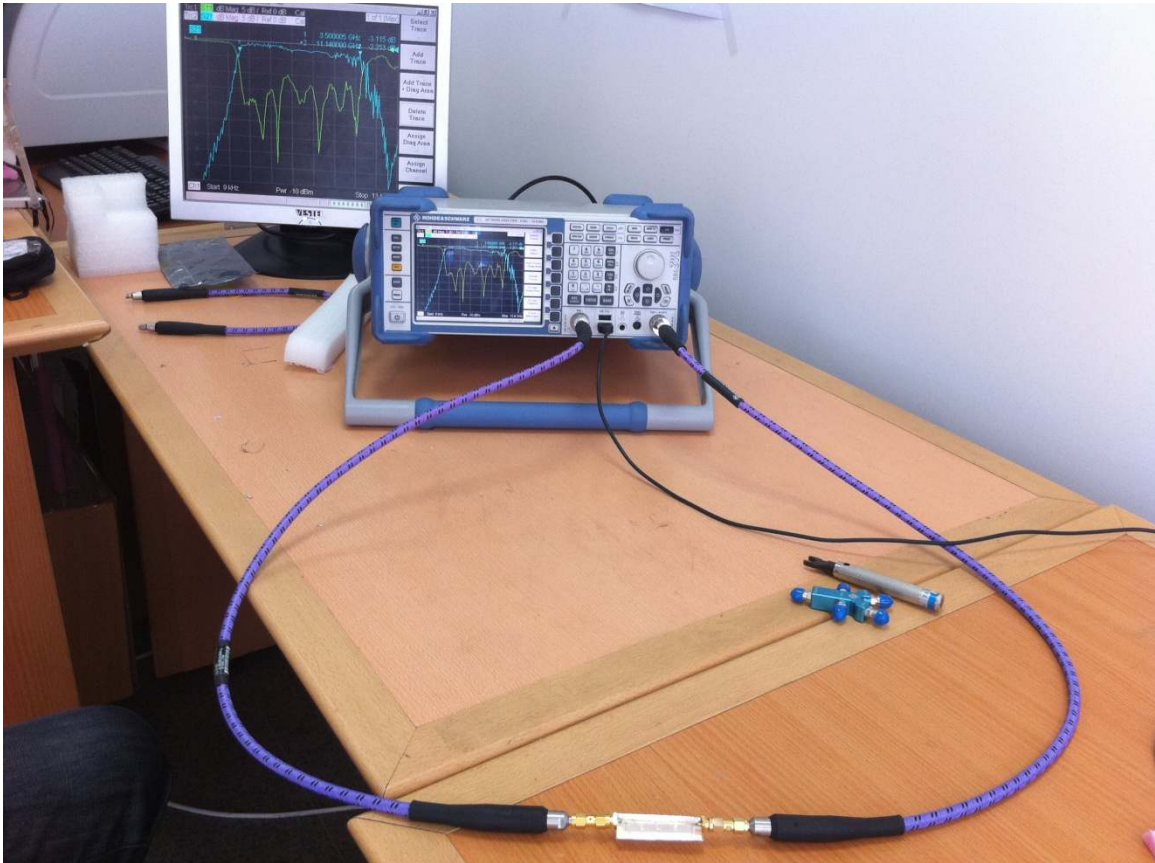

Figure 3.22: The measurement of the Filter Performance, using Network Analyzer

The S-parameter measurement results are given in Fig. 3.23,



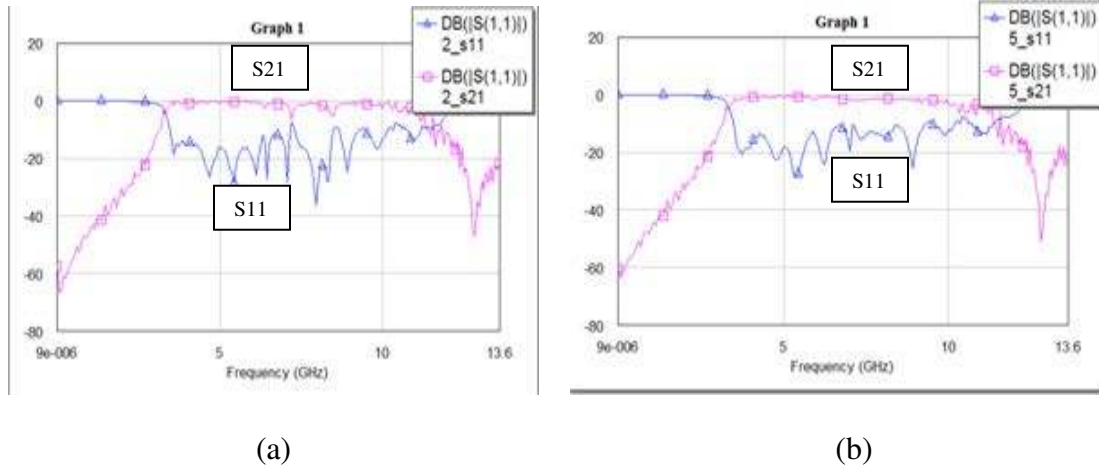

Figure 3.23: Measured S-Parameters of the Filter (a-before tuning, b-after tuning)

The measured return loss is typically better than -10dB within the band of 3.4 – 11 GHz. The measured return loss is similar to the simulated results in AWR and CST. On average, within the band, there is about 5dB return loss difference between the simulated and measured results. While the measured results mostly meet the specifications, a minor tuning makes the response better.

### 3.10. Debugging and Final Filter Measurements

Initial results showed that the return loss needs improvement (Fig. 3.24 a). Main reason appeared that the filter was not well grounded on the side edges in the beginning, vias were not well filled with conducting paste.

In order to investigate the series line capacitances, a tolerance analysis is also done by varying only the series transmission lines' widths by 5% and 10% by using AWR, as shown in Fig. 3.24.

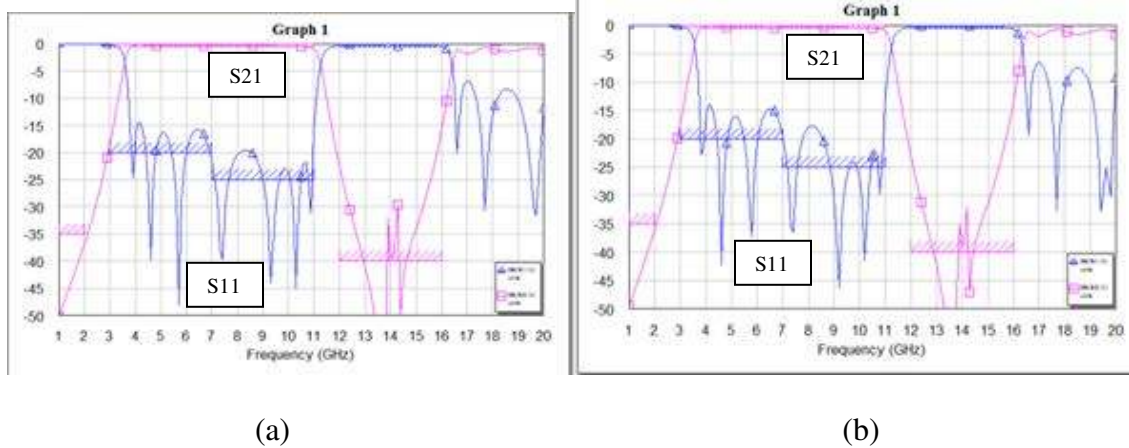

Figure 3.24: AWR Simulation Results due to tolerance analysis (series lines' widths)

Then an aluminum foil is taped on both sides to improve the grounding and compensate the capacitance of the series lines. This grounding also eliminates the microwave signal leakages thru the edges. This way, the field is confined within the filter circuit and sufficient grounding is implemented to eliminate any parasitic effects.

The higher insertion loss in measurements leads us to believe that there is some additional loss in the circuit which is not considered in the simulations. The degraded insertion loss performance may be because of the dielectric substrate, connectors, and vias' imperfections.

In the design, via diameters are modeled due to the smallest vertical linewidths as in 0.02 inch. Then, all the shunt linewidths came with a via at the end. During the LPKF milling process, there has to be ground holes as vias at the ground parts of the filter box in order to make it better. The smallest pin of the LPKF machine for drilling is roughly around 0.02 inch so all the vias and ground holes are milled with that pin to make the diameters as exactly 0.02 inch. That can cause some performance errors in measurement. A tuning would help improve the performance.

The final view of the filter before final measurement is shown on Fig.3.25.



Figure 3.25: The final view of the filter at the final measurement process

The final Network Analyzer measurement results for the filter are given in Fig.

3.26. (used Anritsu MS4644A Vector Analyzer for measurements)

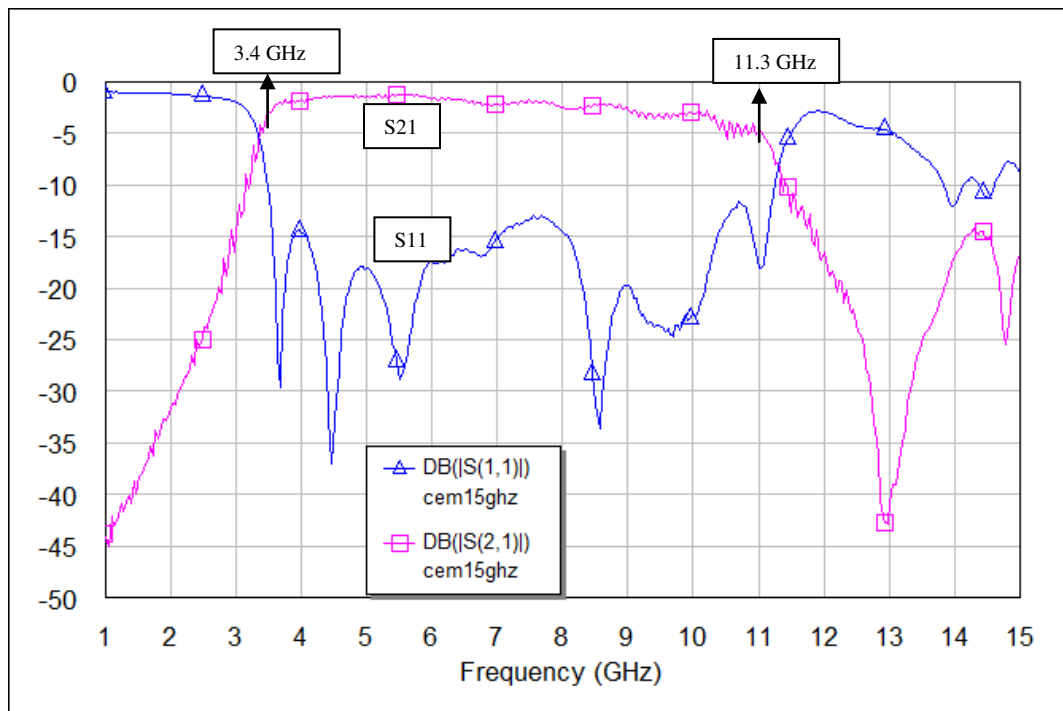
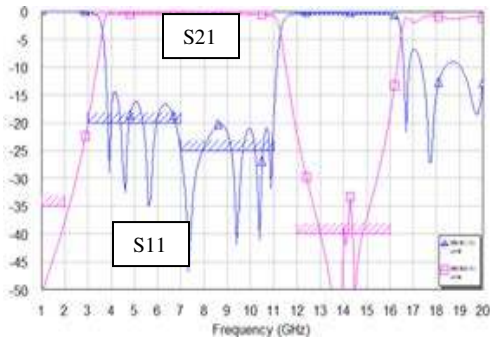

Figure 3.26: The final S-parameter measurements of the filter

### 3.11. Further Development

After debugging and more tolerance analysis processes, it is observed that an increase in the line lengths of the transmission lines would shift the band which helps meeting the original filter specs better. A %10 increase in line lengths would give better result as seen in Fig. 3.27.



(a) Original UWB filter result

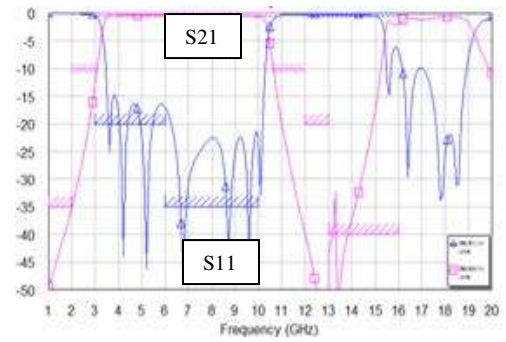

(b) %10 increase in linelengths as best result

Figure 3.27: Linelength analysis in simulation for further development

**CHAPTER 4**  
**CONCLUSION**

## 4. Conclusion

In this master thesis, an UWB microstrip band pass filter was built with 3.6-10.6 operating frequency range. The electrical requirements were as follows:

- -10 dB rejection at 3.1 GHz
- -10 dB rejection at 10.6 GHz
- Insertion Loss < 3 dB, 3.6-10.1 GHz
- Return Loss better than -10 dB within the band

Final measurement results of the fabricated filter prototype are very close to the specs as follows:

- ✓ -10 dB rejection at 3.4 GHz
- ✓ -10 dB rejection at 11.3 GHz
- ✓ Insertion Loss < 4dB, 3.6-10.1 GHz
- ✓ Return Loss better than -10 dB within the band

The return loss is better than -10 dB within the band which seems satisfactory for a nominal UWB filter. The insertion loss can be improved with a proper manufacturing and processing. -35 dB rejection at 2 GHz is obtained. -10 dB rejection on the low end is achieved, however, due to wider band than expected, -10 dB rejection occurs at around 11.3 GHz on the high end. A minor tuning will improve the filter performance.

Once this tuning process is done, this developed filter can be used as a part of a RF-front end module in an UWB receiver module.

## References

- [1] Ian D. O'Donnell, Mike S. W. Chen, Stanley B. T. Wang, Robert W. Brodersen, An Integrated, Low Power, Ultra-Wideband Transceiver Architecture for Low-Rate, Indoor Wireless Systems, *IEEE CAS Workshop on Wireless Communications and Networking, Pasadena, CA, USA, September 2002*
- [2] David D. Wentzloff, Fred S. Lee, Denis C. Daly, Manish Bhardwaj, Patrick P. Mercier, and Anantha P. Chandrakasan, Energy Efficient Pulsed-UWB CMOS Circuits and Systems, *ICUWB Conference, Singapore, 24-26 September 2007*
- [3] Stanley B. T. Wang, Ali M. Niknejad, and Robert W. Brodersen, Design of a Sub-mW 960-MHz UWB CMOS LNA, *IEEE Journal of Solid-State Circuits, November 2006*
- [4] Joshi M, Ultra Wide Bandwidth, *International Conference on Education Technology and Computer (ICETC), Shanghai, 22-24 June 2010*
- [5] Ching-Luh Hsu, Fu-Chieh Hsu, and Jen-Tsai Kuo, Microstrip Bandpass Filters for Ultra Wide Band (UWB) Wireless Communication, *Microwave Symposium Digest, 2005 IEEE MTT-S International, 12-17 June 2005*
- [6] I-Tseng Tang, Ding-Bing Lin, Chi-Min Li, and Min-Yuan Chiu, Ultra-Wideband Bandpass Filter Using Hybrid Microstrip-Defected-Ground Structure, *Microwave and Optical Technology Letters/Vol.50, No.12, December 2008*
- [7] Zhewang Ma, Wenqing He, Chun-Ping Chen, Yoshio Kobayashi, and Tetsuo Anada, A Novel Compact Ultra-Wideband Bandpass Filter Using Microstrip Stub-Loaded Dual-Mode Resonator Doublets, *IEEE Magazine, 2008*

- [8] P. K. Singhal, Suman Mathur, and R. N. Baral, Ultra-wide microstrip band pass filter using short circuited stubs, *Journal of Electrical and Electronics Engineering Research Vol. 3(6)*, pp. 101-107, August 2011
- [9] Wen-Hua Tu, and Kai Chang, Compact Second Harmonic-Suppressed Bandstop and Bandpass Filters Using Open Stubs, *IEEE Transactions on Microwave Theory and Techniques*, vol. 54, no. 6, June 2006
- [10] Amin M. Abbosh, Design Method for Ultra-Wideband Bandpass Filter With Wide Stopband Using Parallel-Coupled Microstrip Lines, *IEEE Transactions on Microwave Theory and Techniques*, Vol 60 No1, January 2012
- [11] A.K.Keskin, H.P.Partal, An UWB High-Q Bandpass Filter with Wide Rejection Band using Defected Ground Structures, *2012 IEEE International Conference on Ultra-Wideband Syracuse, NY, 17-20 September 2012*
- [12] Matthaei,G.L, Design of parallel-coupled resonator filters, *Microwave Magazine,IEEE,Volume:8,Issue:5,2007*
- [13] Weng, L. H., Y. C. Gue, X. W. Shi, and X. Q. Chen, An overview on defected ground structure, *Progress In Electromagnetics Research B*, Vol. 7, 173–189, 2008



# CEM CANSEVER

241 Lafayette Rd. 204, Syracuse, NY 13205  
(315) 378-3200 ccanseve@syr.edu

## EDUCATION

**Syracuse University**, Syracuse, New York May 2013  
L.C. Smith College of Engineering and Computer Science  
M.S., Electrical Engineering  
Master Thesis: Design of a Microstrip Bandpass Filter for 3.1-10.6 GHz UWB Systems

**Kadir Has University**, Istanbul, Turkey May 2010  
B.S., Electrical-Electronics Engineering  
Thesis: Temperature Control in Home Automation Systems via RF Communication

## TECHNICAL SKILLS

**Programming Languages:** C, C++, C#, HTML, Assembly, Matlab Simulink  
**Administrative:** MS Office, Word, Excel, PowerPoint, Outlook, Visio, MathType, Adobe Photoshop  
**Engineering:** MatLab, MathCad, AutoCAD, AWR MicrowaveOffice, Agilent Genesys, Sonnet EM Simulation, CST EM Simulation  
**Microwave:** RF Circuit Design, Filters, Antennas, Oscillators, Couplers, Baluns, VCO, LNA

## PROFESSIONAL EXPERIENCE

**Research Assistant, Syracuse University** (August 2010-December 2011) **Scholarship:**  
Microwave and RF Applications -Mastery of using microwave theory concepts to design and optimize microwave circuits to predict their behaviors and specifications. Investigation on microwave circuits such as filters, amplifiers, oscillators, and antennas to explore basic design and measurement techniques. Measurements of those systems with vector network analyzer and spectrum analyzer for system responses.  
**Electrical - Electronics Engineering Intern, Nortel Networks Netas Telecommunication, Istanbul, Turkey** (June 2009): Contributed development of system networks that serves Turkey telecommunication market  
**Electrical - Electronics Engineering Intern, Phoenix Contact, Blomberg, Germany** (July 2008): Development of home automation systems by RF communication and implementation of an automation system with PLC

## PROJECTS & CONFERENCES

IEEE International Conference on Ultra-Wideband, ICUWB, Syracuse (2012)  
Research on Microwave Passive Filters with high selectivity and harmonic rejection (Summer 2011)  
Antenna and Antenna Systems Design Applications (Fall 2011)  
Independent Study on Microwave Measurements (Fall 2011)  
IEEE Workshop on Microwave Passive Circuits and Filters, Syracuse (2010)  
Microwave Oscillator Design using AWR DE Simulation Tool (Summer 2010)  
International IEEE Conference Eurocon , St.Petersburg, Russia (2009)  
HABTEKUS, Yildiz Technical University, Istanbul, Turkey-Organizer, Presenter (2009-2008-2007)  
Contribution to wireless communication network protocols and WiMAX project (Fall 2008)  
Implementation of an automation system with PLC by RF communication (Summer 2008)  
Microprocessor Programming Application in Assembly (Spring 2008)  
Digital Signal Processing Application in Matlab (Fall 2007)

## ENGINEERING INVOLVEMENT

IEEE, Member (2011-Present)  
Chamber of Turkish Electrical Engineers Association, Member (2009-Present)  
Society of Biguk Members in Kadir Has University, Istanbul, Turkey, Member (2008-2009)  
Society of Electrical Engineers Community, Member (2005-2009)