

 Open access • Journal Article • DOI:10.1063/1.2222333

Design of a tangential phase contrast imaging diagnostic for the TCV tokamak

— [Source link](#) 

Alessandro Marinoni, Stefano Coda, René Chavan, G. Pochon

Institutions: École Polytechnique Fédérale de Lausanne

Published on: 19 Oct 2006 - Review of Scientific Instruments (American Institute of Physics)

Topics: Plasma shaping, Spatial filter, Tokamak, Phase-contrast imaging and Plasma diagnostics

Related papers:

- [The phase contrast method as an imaging diagnostic for plasma density fluctuations \(invited\)](#)
- [Electron temperature gradient driven turbulence](#)
- [Vertical localization of phase contrast imaging diagnostic in Alcator C-Mod](#)
- [Millimeter Wave Imaging and Visualization of Plasma Waves and Instabilities](#)
- [A phase contrast interferometer on DIII-D](#)

Share this paper:    

View more about this paper here: <https://typeset.io/papers/design-of-a-tangential-phase-contrast-imaging-diagnostic-for-3au5i2v1xf>

Design of a tangential Phase Contrast Imaging diagnostic for the TCV tokamak



A. Marinoni, S. Coda, R. Chavan, G. Pochon

alessandro.marinoni@epfl.ch

Ecole Polytechnique Fédérale de Lausanne (EPFL), Centre de Recherches en Physique des Plasmas
Association Euratom-Confédération Suisse, CH-1015 Lausanne, Switzerland

16th Topical Conference on
High-Temperature Plasma Diagnostic
Williamsburg, Virginia 2006
Poster TP71

Aims

- Investigate core density fluctuations in the TCV tokamak, particularly in strongly ECRH-heated plasmas
- Overcome difficulties faced by standard turbulence techniques in highly inhomogeneous plasmas by means of an imaging technique
- Localize the measurements thanks to a toroidal injection configuration
- Infer correlation and spectral properties of turbulence from electron to ion scales
- Study link of turbulence to electron transport in strongly ECRH-heated TCV plasmas, particularly in advanced scenarios such as internal transport barriers

The TCV tokamak

The Tokamak à Configuration Variable has the following characteristics

- Major radius 0.88 m
- Minor radius 0.25 m
- Inner height of the vacuum vessel 1.5 m
- Vacuum toroidal field 1.44 T
- Plasma current up to 1 MA
- Highest triangularities achieved 1 and -0.7
- Maximum elongation achieved 2.8
- Installed ECRH power 4.3 MW
- Discharge duration 2 s (max 4 s)

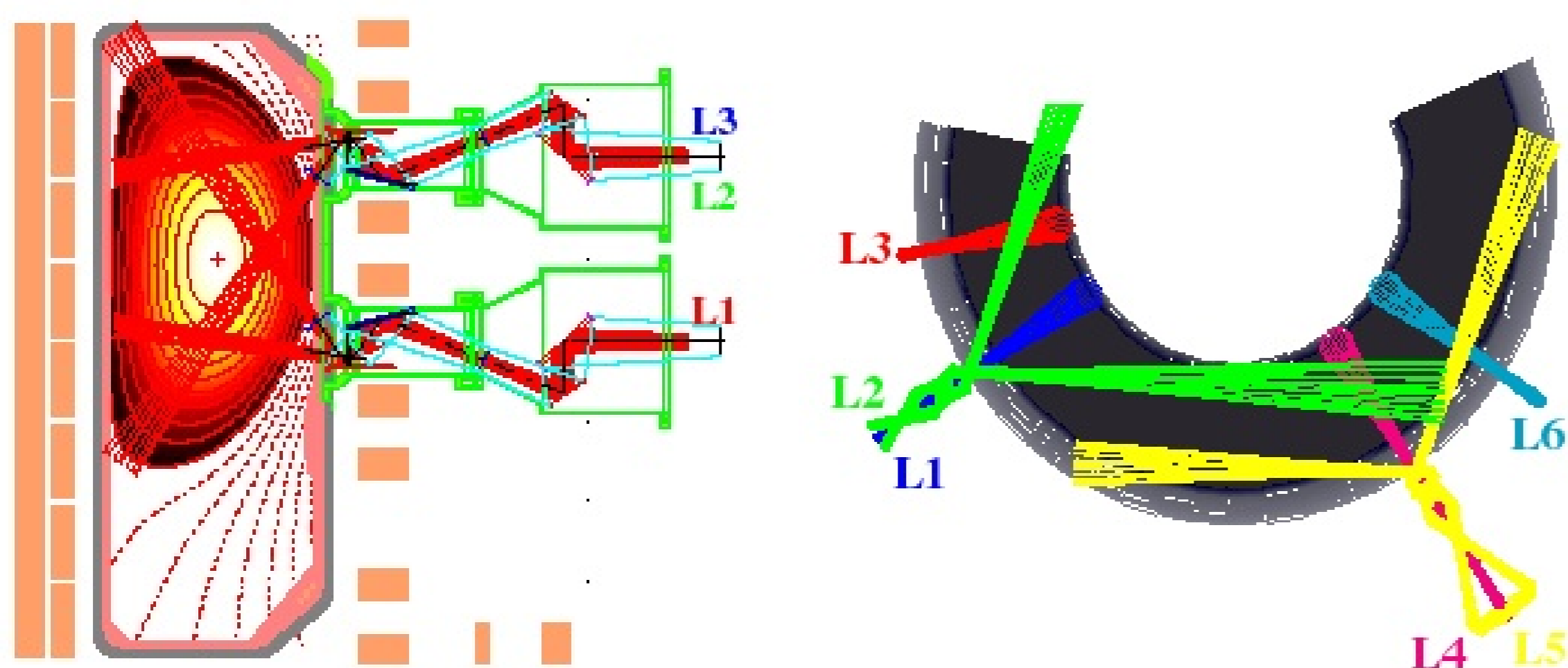
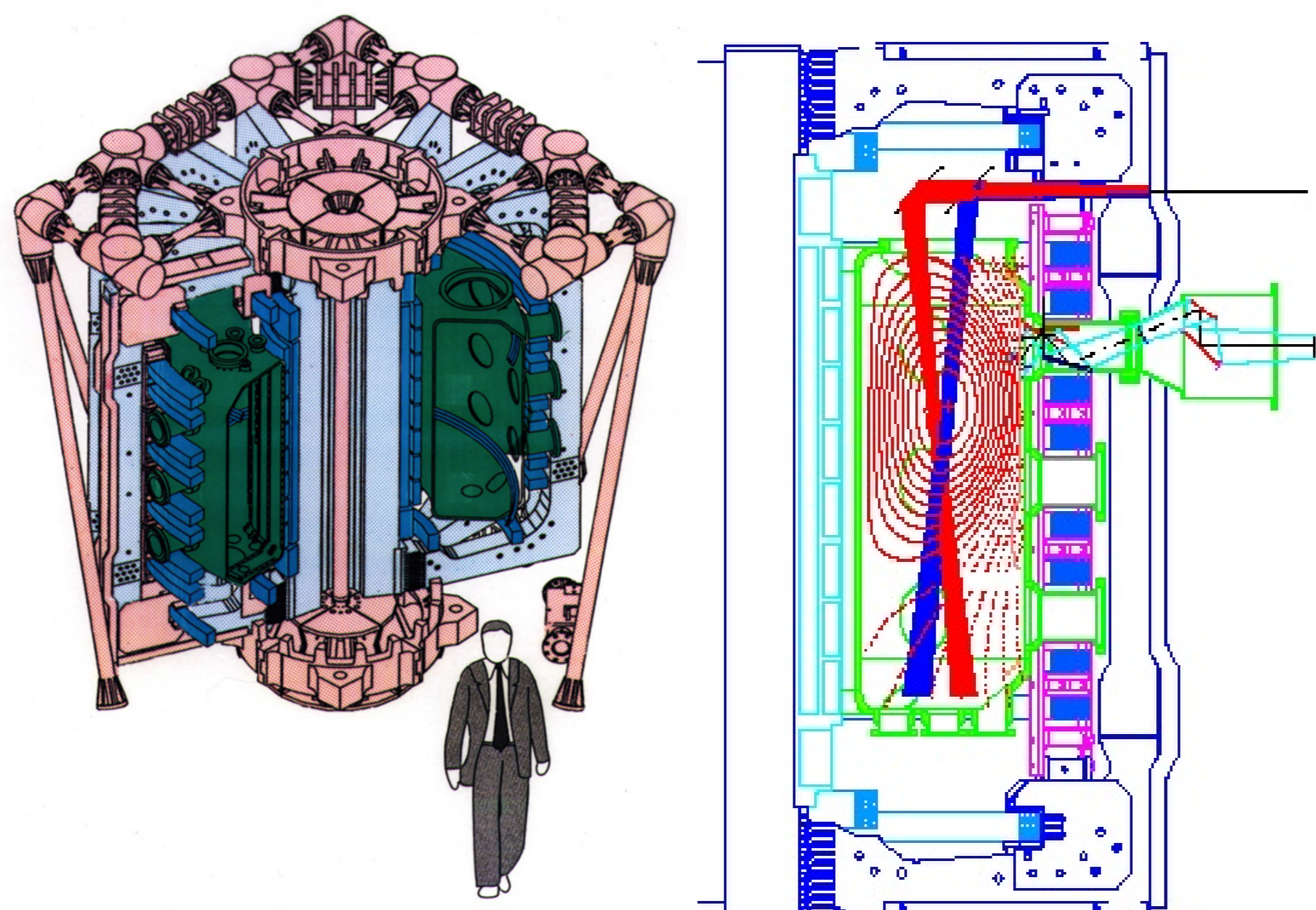

(a) The TCV tokamak. (b) The third-harmonic (118 GHz, 1.5 MW) ECRH system. Poloidal (c) and toroidal (d) views of the second-harmonic (82.7 GHz, 2.8 MW) ECRH system.

The Phase Contrast Imaging technique

- PCI is an internal reference interferometer able to image phase variations, which in turn are proportional to density fluctuations [1]

$$\Delta\Phi(\vec{x}) \simeq r_e \lambda_0 \int_{\vec{x}_1}^{\vec{x}_2} dn_e(\vec{x}) \quad (1)$$

- Its principle is based upon the recombination of the scattered and the unscattered beam after introducing a $\pi/2$ phase shift with respect to each other
- The $\pi/2$ phase shift transforms phase fluctuations into amplitude fluctuations
- The resulting light intensity is linearly proportional to the phase fluctuations

$$I(\vec{x}, t) \simeq |E_0|^2 [1 \pm 2\Delta\Phi(\vec{x}, t)] \quad (2)$$

- The internal reference minimizes the sensitivity to mechanical vibrations, thus increasing the sensitivity of the measurement compared to standard interferometry.
- Being an imaging technique it is not constrained to sample uniform plasma regions

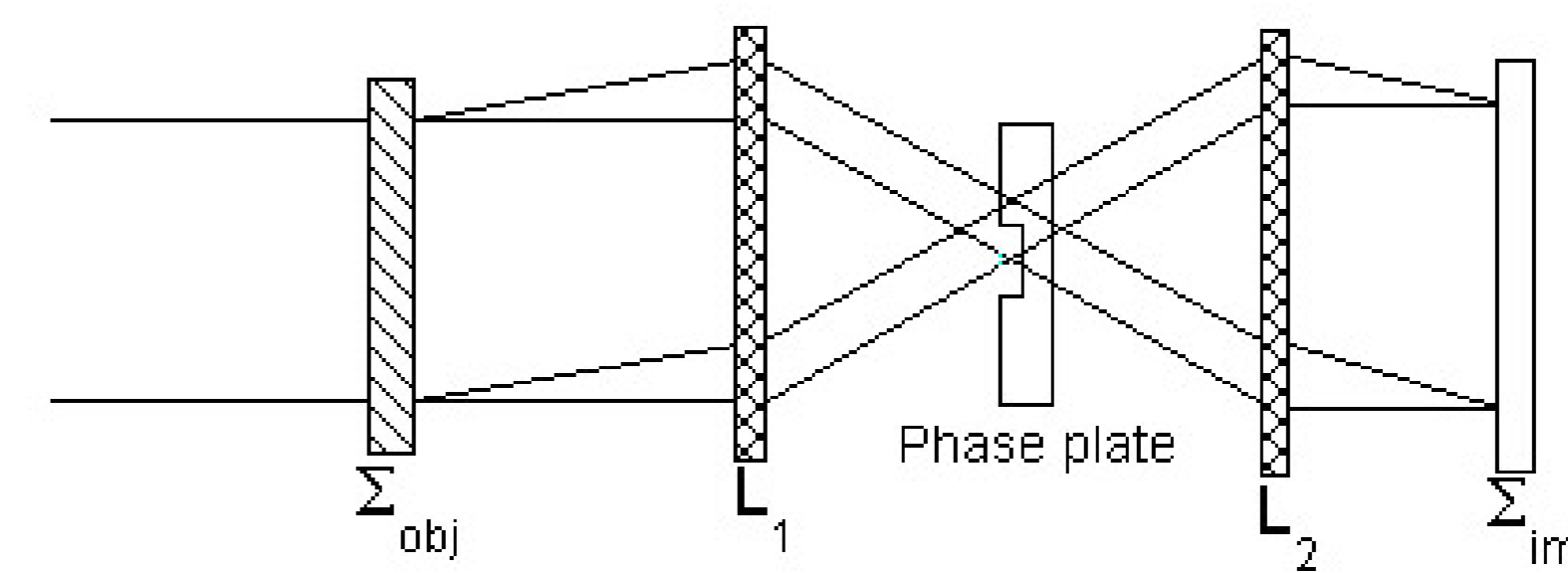

Basic setup for phase contrast. Σ_{obj} : object plane
 Σ_{im} : image plane. L_1, L_2 : focusing and imaging lenses

Localization method

- PCI is intrinsically a line integrated measurement
 - PCI, like any line-integrated measurement, is sensitive only to fluctuations which lie in a plane perpendicular to the beam wave front
 - In magnetized plasmas fluctuations are aligned along the magnetic field line, i.e. $k_{\parallel} \ll k_{\perp}$
- ⇒ Measured fluctuations lie in a plane perpendicular to both the magnetic field line and to the beam direction, i.e. along the $\vec{k}_0 \wedge \vec{B}$ direction

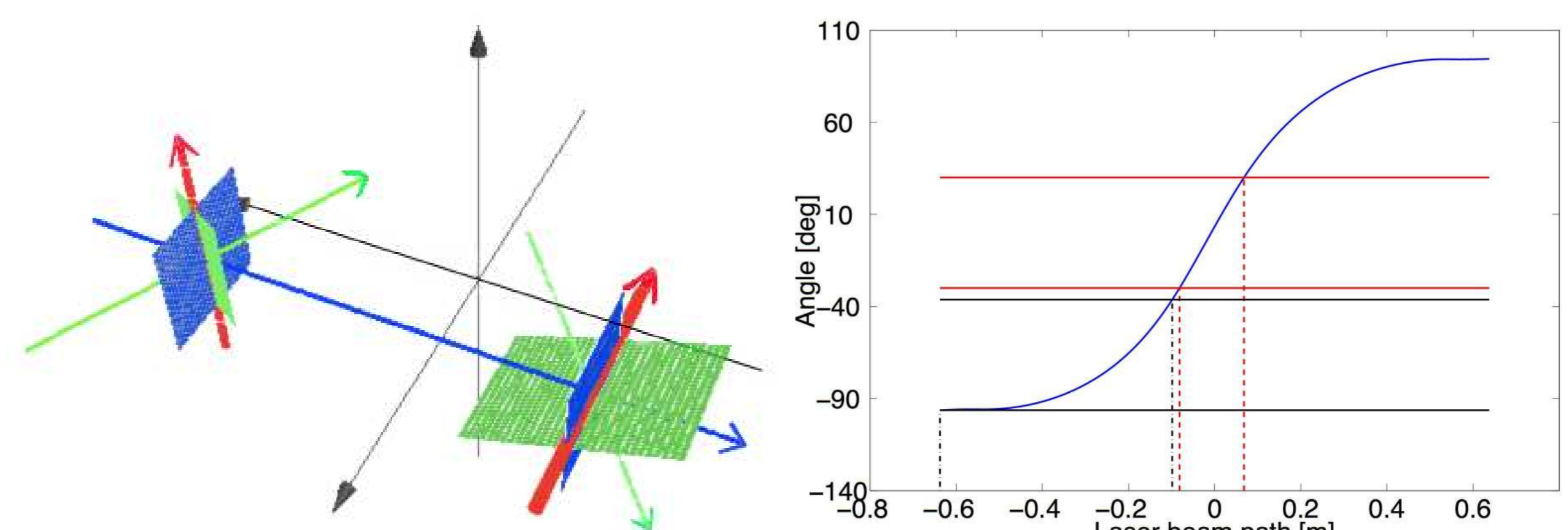

(Left) • Laser beam. • magnetic field line • Selected directions of fluctuations. (Right) Direction of the selected fluctuations with respect to a reference (horizontal) direction vs a linear coordinate along the laser beam path. The red dashed box indicates the good resolution region. The black dash-dotted box represents a poor resolution case.

- The direction of the scattering vector in the wave-front plane can be chosen by spatial filtering at the focal plane.
- If the angle formed by the projection of the magnetic field line on the beam wave front with respect to a given direction is a single-valued, steep and monotonic function of the beam path, it is possible to select a particular angle range and so a particular interaction region.

What is needed to localize

- PCI focuses the beam in order to separate diffracted and undiffracted components on the phase plate, where a $\pi/2$ phase shift is introduced.
- Scattered light is focused on the focal plane in a point which corresponds to the fluctuating k sampled.

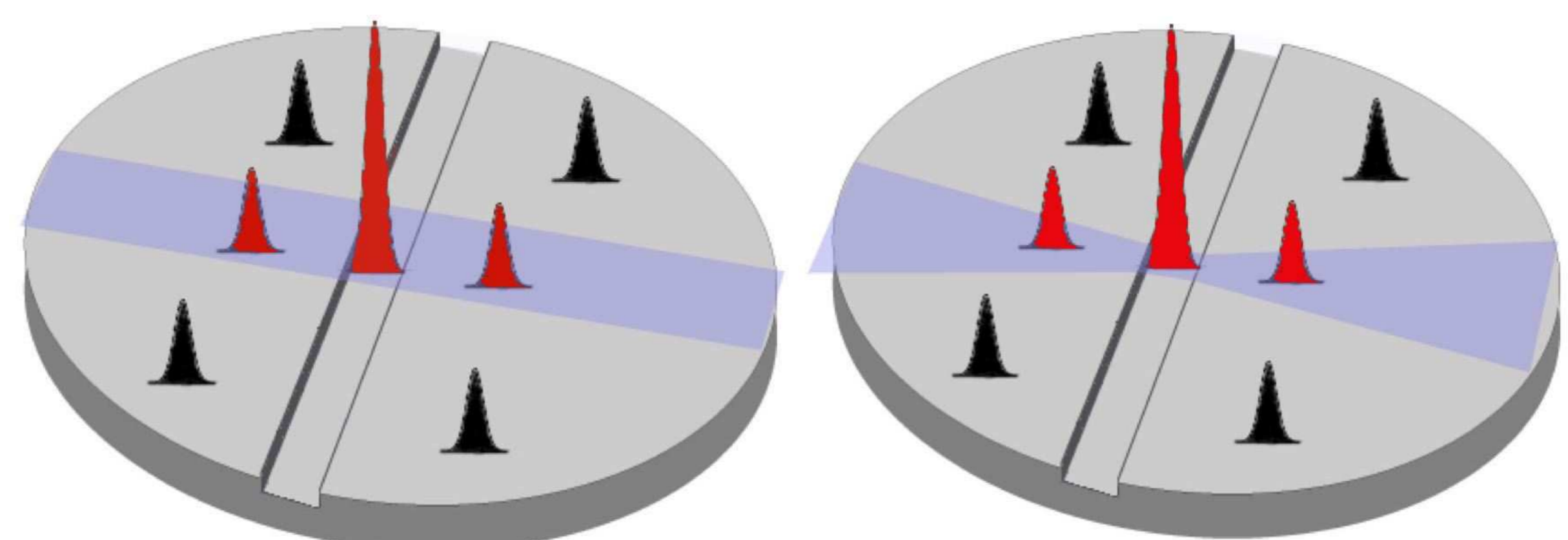

Picture illustrating the focusing of scattered and unscattered beams on the phase plate. Only radiation passing through the spatial filter, represented in blue, can impinge on the phase plate; this radiation is represented in red. Two possible filter configurations are depicted here.

- The application of a spatial filter on a focal plane allows the selection of a given angular range whose width is determined by the diffraction limit.
- The diffraction limit is expressed as Δk ; since the angular range is $\sim \Delta k/k$, the maximum achievable localization improves with k (as $1/k$).
- To ensure a uniform response over the k spectrum and thus a true imaging, the spatial filter can be designed to provide the same localization for each k (example on the right).

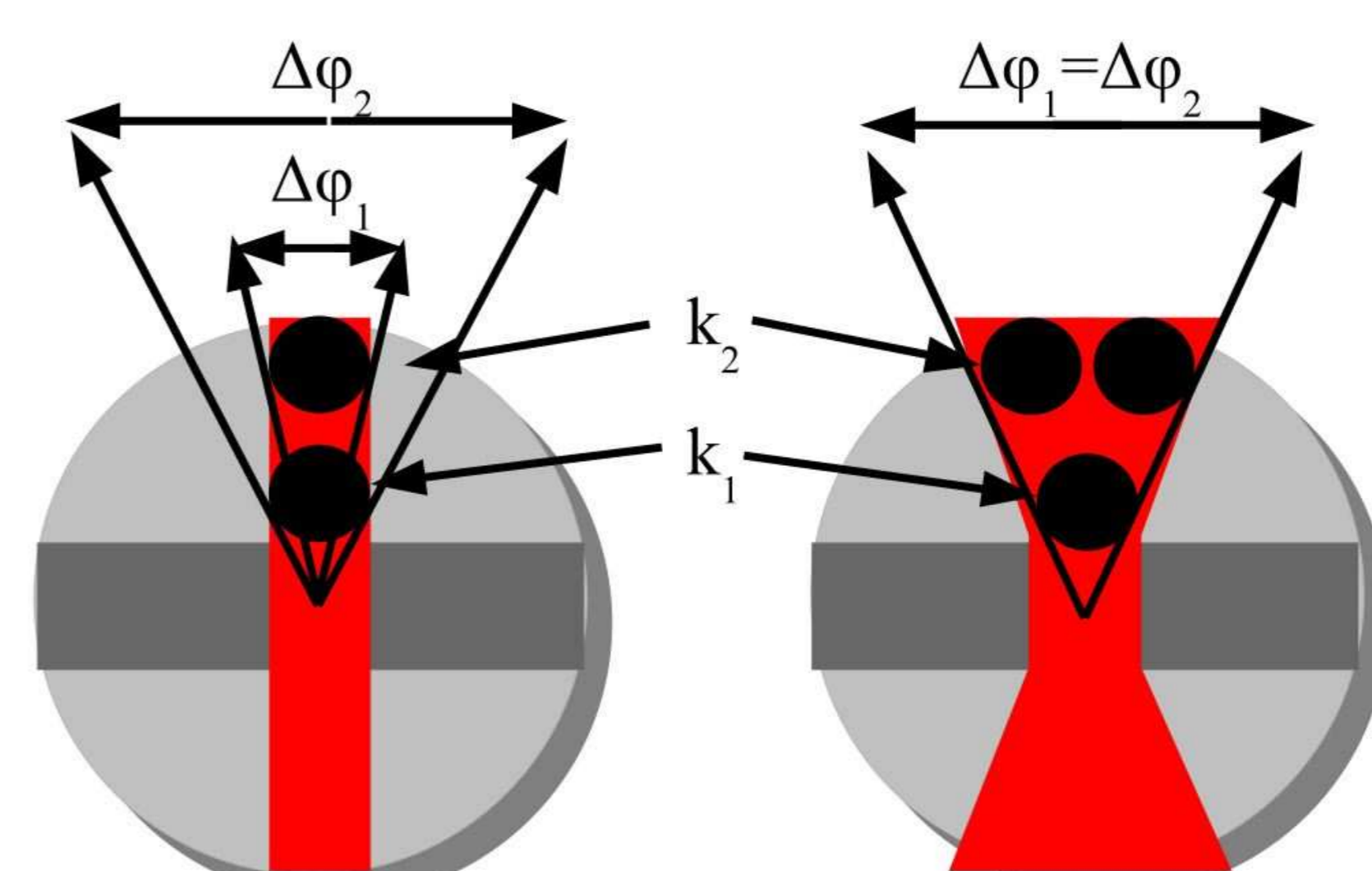

Schematic picture illustrating how the spatial filter (•) acts on scattered light (•) corresponding to two different k values impinging on the phase plate (•); the phase groove is indicated as the horizontal bar (•). On the left it is shown how a normal filter distorts the spectral response of the system, while on the right a more appropriate filter shape has a constant transfer function.

Design of a tangential Phase Contrast Imaging diagnostic for the TCV tokamak



16th Topical Conference on
High-Temperature Plasma Diagnostic
Williamsburg, Virginia 2006
Poster TP71

Expected localization in TCV

- The best configuration is a co-field toroidal injection, i.e. with a small vertical propagation component to match the pitch angle at the desired location.

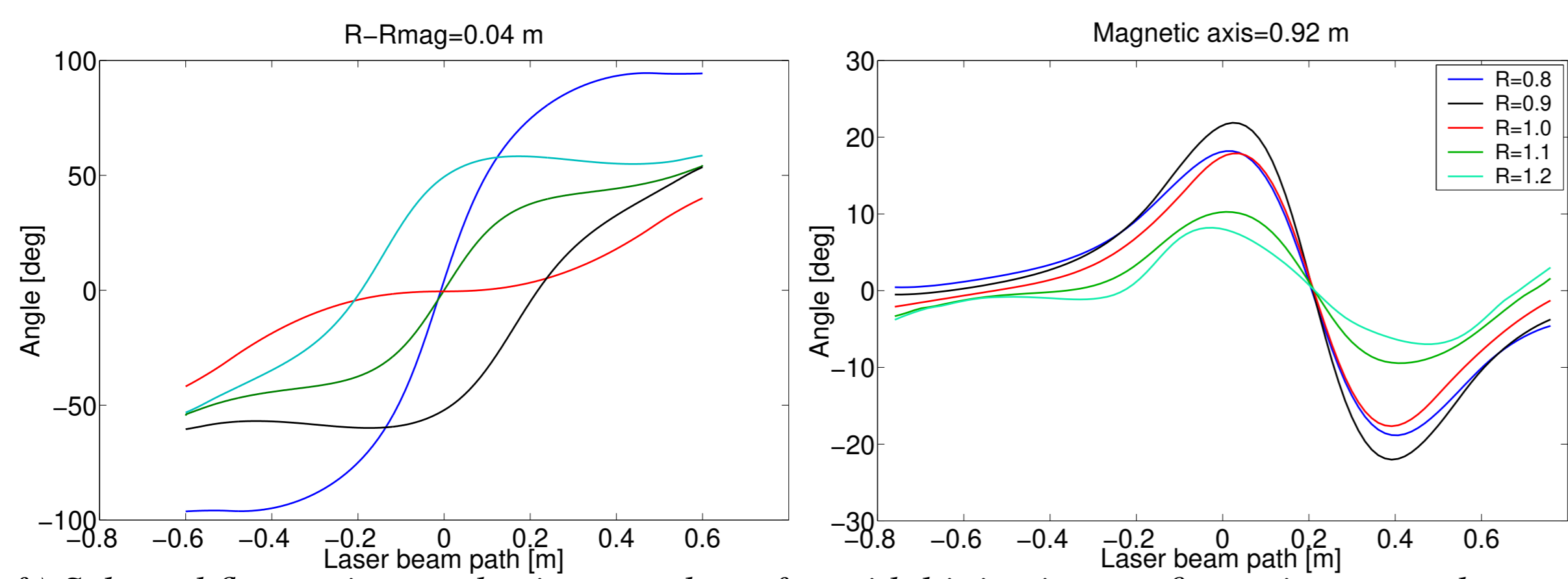

(Left) Selected fluctuating angles in a number of toroidal injection configurations: purely toroidal through, above and below magnetic axis (●-●-●), oblique in the magnetic field line direction (●) and opposite to it (●) (in both cases passing through the magnetic axis). (Right) Same as left but in a case of vertical injection, for different horizontal distances from the magnetic axis.

- The localization is not modified significantly by a reversed shear configuration

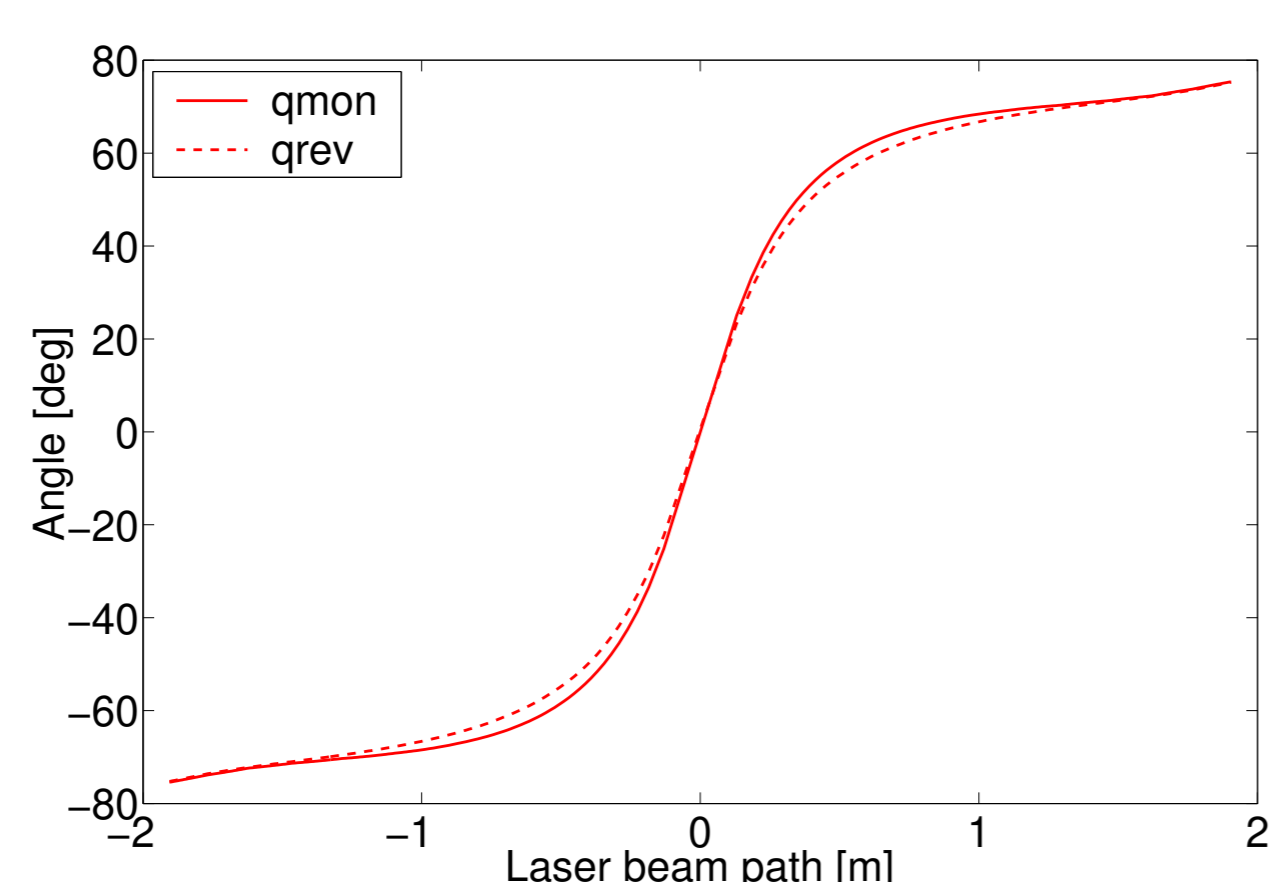

- The key-point is to choose a location where the beam is almost tangent to a given flux-surface. Two effects then contribute to the good localization: (a) steep derivative of angle vs. linear coordinate, (b) steep derivative of linear coordinate vs. ρ

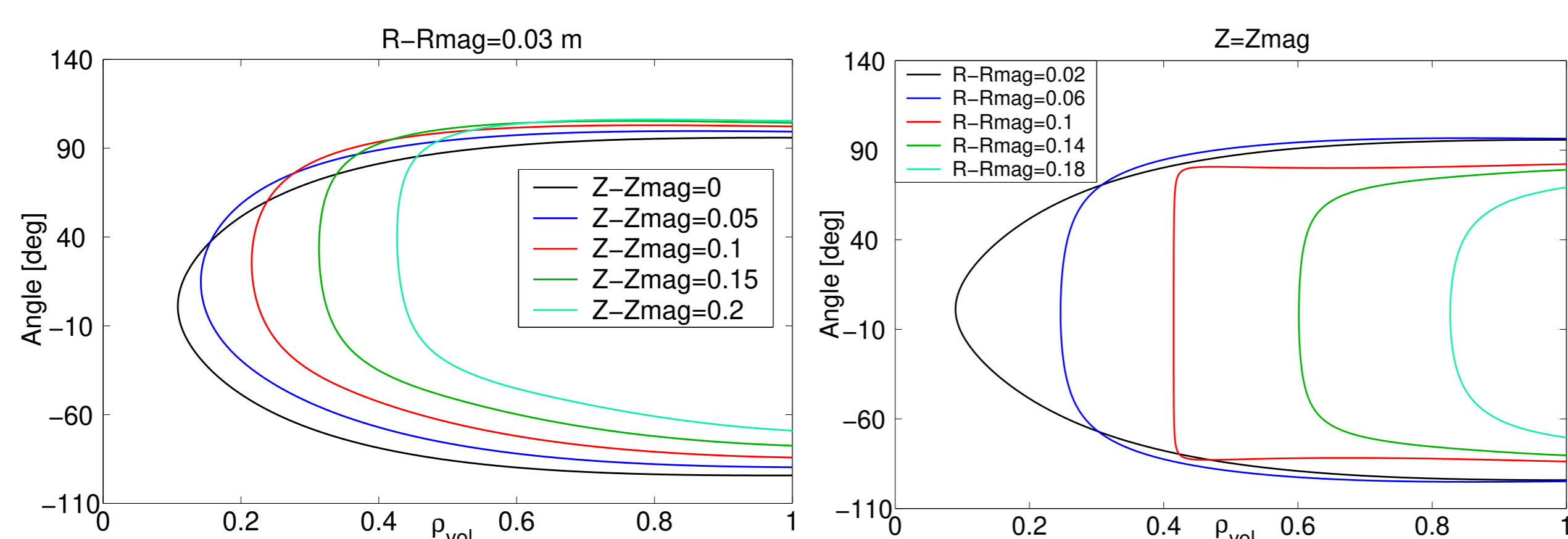

- Resolution in the poloidal cross section reaching values of 10^{-2} of the minor radius, for a minimum wave number of 0.9 cm^{-1}

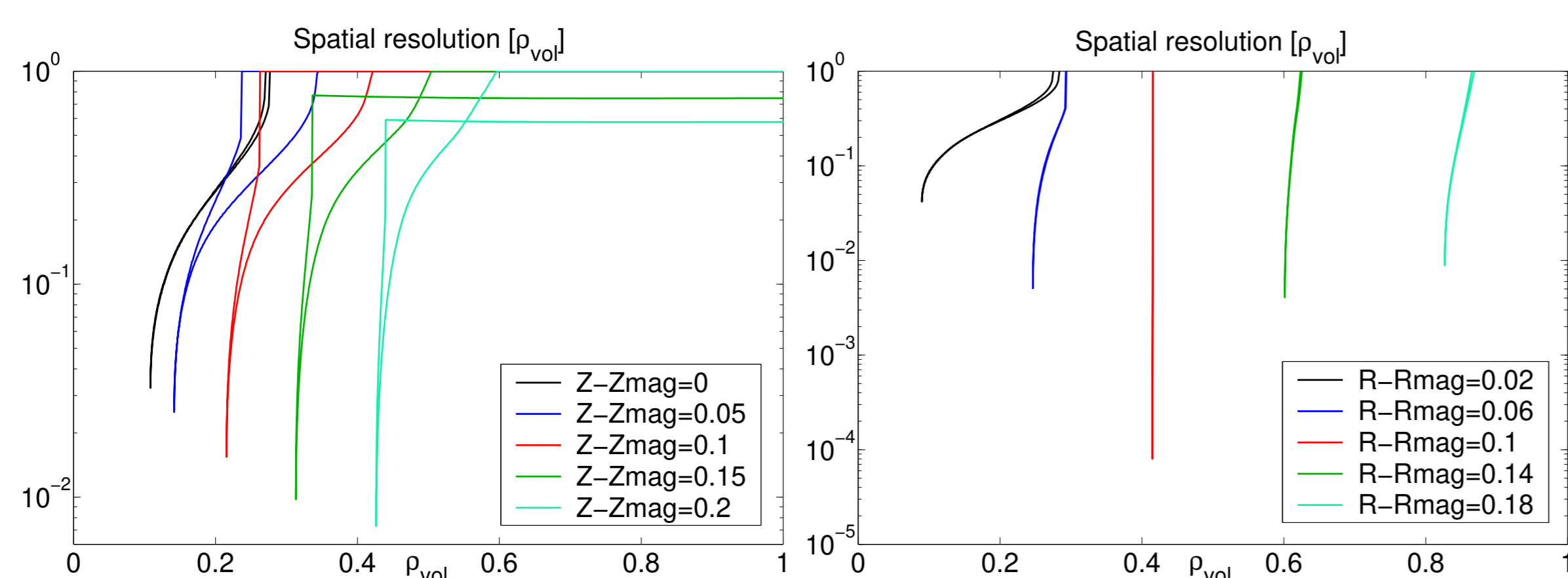

- A given wave-vector direction in the lab frame corresponds to varying k_{ρ} and k_{θ} components at different locations along the beam, leading to wave-vector mixing from the finite integration length. Depicted here are the expected fluctuating k selected and its uncertainty

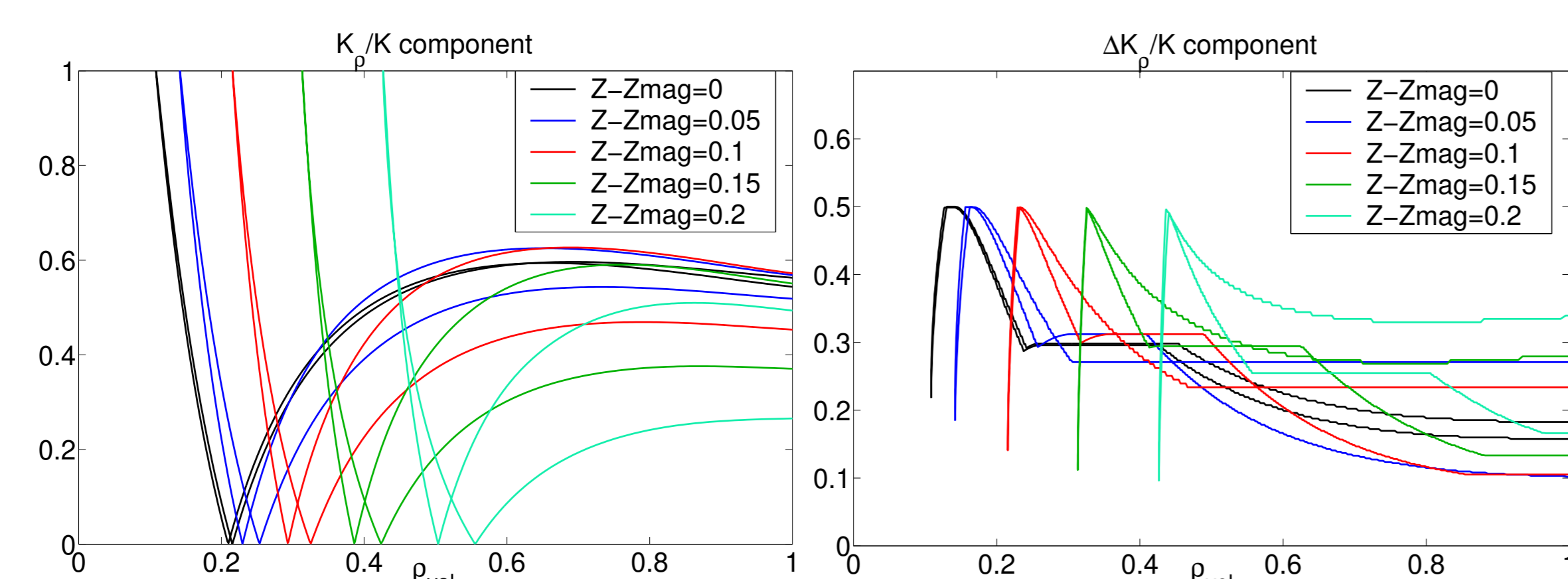

Experimental apparatus

- Translatable setup in order to make measurements close to the magnetic axis in some configurations, exploiting the extreme flexibility of TCV in terms of plasma shape and positioning
- Measurable fluctuations are in the range $0.9 \div 60 \text{ cm}^{-1}$
- Minimum measurable line-averaged density of $3 \cdot 10^{15} \text{ m}^{-3} / \text{MHz}^{1/2}$
- Detector array with 30 elements and 1MHz bandwidth plus 1 element with 10 MHz bandwidth.
- Acquisition rate = 12.5 MSamples/s
- Can reverse fields in order to study differences in Doppler shifts and thus in plasma fluxes



ÉCOLE POLYTECHNIQUE FÉDÉRALE DE LAUSANNE
POLITECNICO FEDERALE DI LOSANNA
EIDGENÖSSISCHE TECHNISCHE HOCHSCHULE LAUSANNE
SWISS FEDERAL INSTITUTE OF TECHNOLOGY LAUSANNE

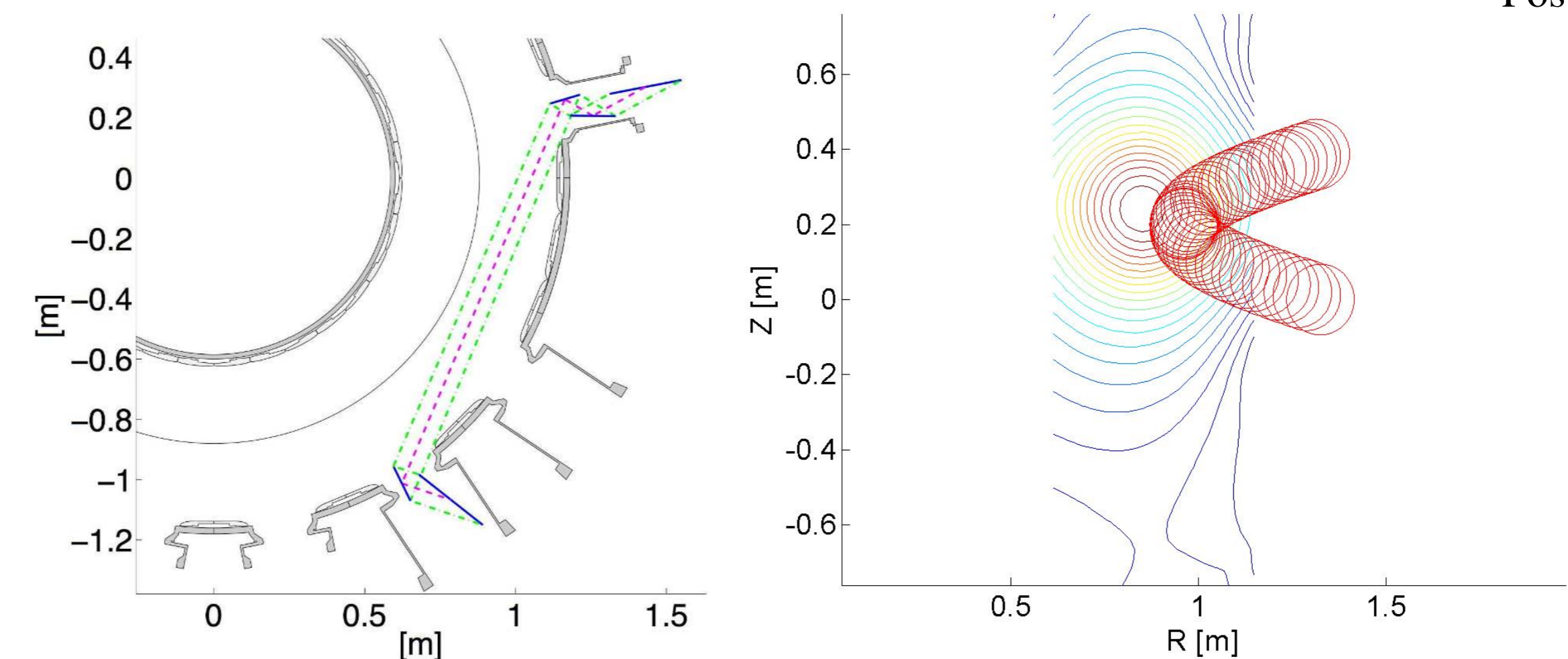

(Left) Top view of the TCV tokamak showing the in-vessel mirrors (●), the laser beam center (●) and end-points (●). (Right) Trajectory of the laser beam projected on the poloidal plane.

Numerical modelling

- We privileged fast-running codes in order to make a general estimate of the types of instabilities at play in TCV
- Codes used are flux-tube KINEZERO [2] and GS2 [3], in the linear electrostatic collisional and collisionless limits
- With reasonable parameters excited frequencies do not exceed 5 MHz in KINEZERO and 1.6 MHz in GS2
- Most unstable modes are in the k region $0.3 \div 3 \text{ cm}^{-1}$
- Expected density fluctuations are estimated according to a mixing-length criterion

$$\frac{\Delta n}{\sqrt{\Delta f}} = 2\pi \nabla n \sqrt{\sum_k \frac{1}{k^2 \gamma_k}} \quad (1)$$

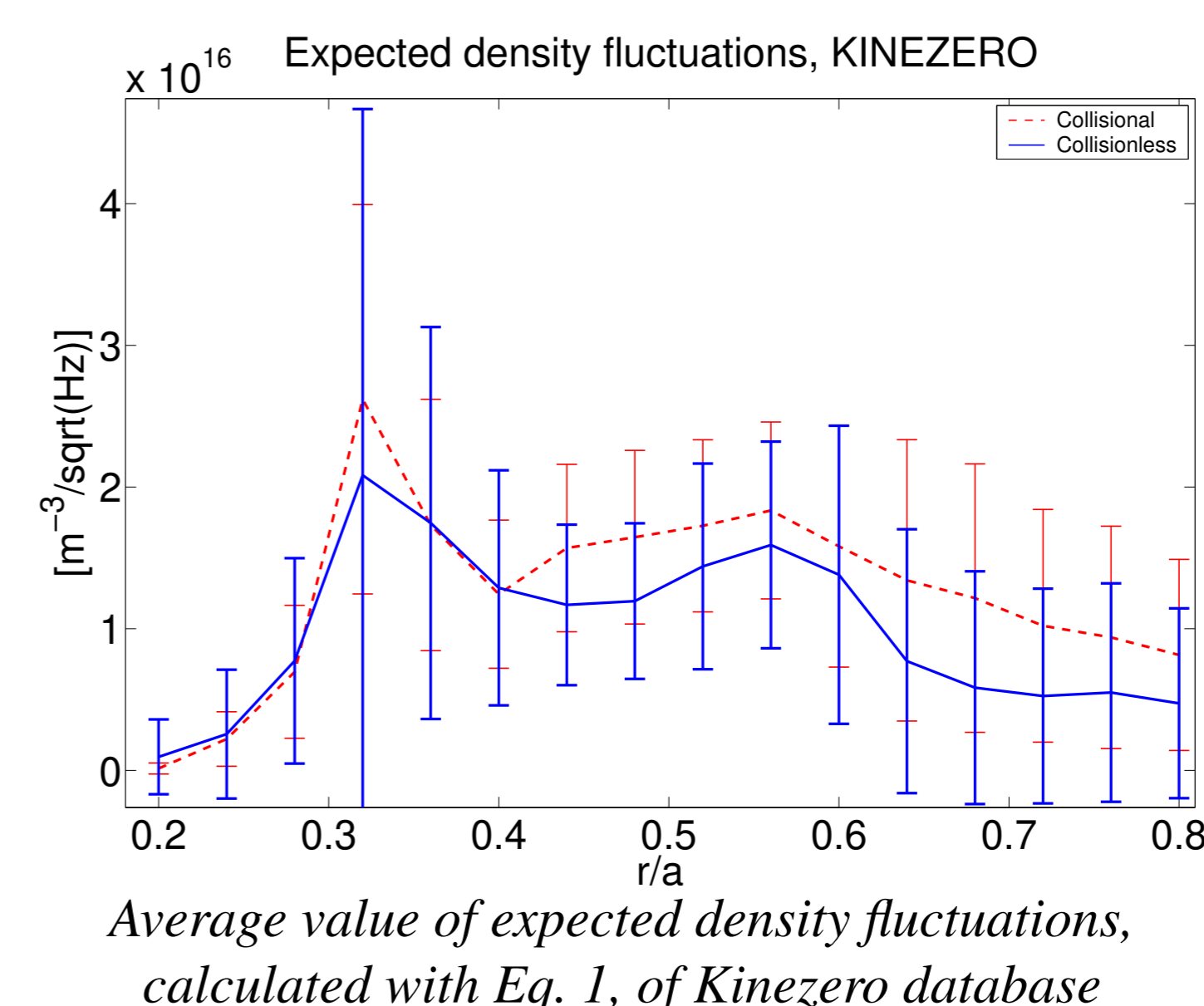

- With the available detectors, considering an integration length of 10 cm, we estimate a minimum detectable fluctuating density equal to $3 \cdot 10^{15} \text{ m}^{-3} \text{MHz}^{-1/2}$ for the detector array and $8 \cdot 10^{14} \text{ m}^{-3} \text{MHz}^{-1/2}$ for the single-element detector.
- GS2 simulations resulted in a minimum fluctuating density of $10^{17} \text{ m}^{-3} \text{MHz}^{-1/2}$ for ITB shots at $\rho = 0.44$ and $6 \cdot 10^{18} \text{ m}^{-3} \text{MHz}^{-1/2}$ at $\rho = 0.72$ for an L mode shot.

Design of the ports assemblies

The present design of the PCI ports is the following

- 5 in-vessel mirrors
- Translatable system in order to place the front mirrors as close as possible to the LCFS, and to allow the beam to reach the magnetic axis in select configurations.
- The two front-mirrors will be steerable in order to ensure alignment in all configurations

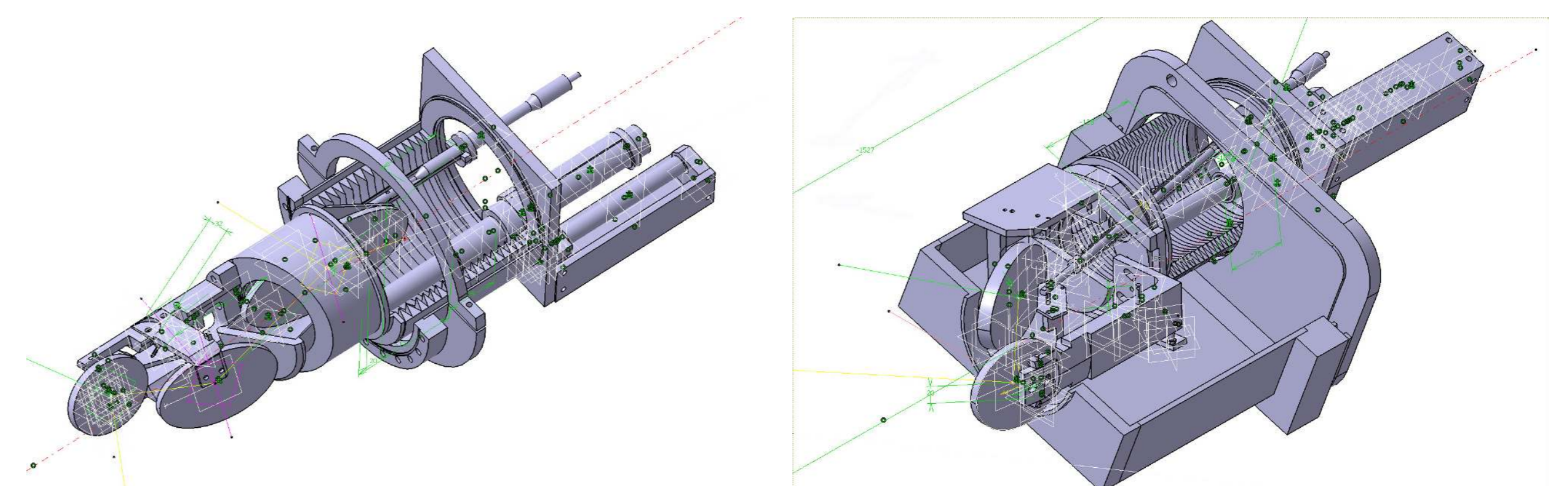

Sketch of the present design of the ports. In the picture are depicted the mirrors, the vacuum interface window, the translation stage on bellows and the screw actuator used to adjust the orientation of the plasma-facing mirror

Acknowledgements

The Authors would like to thank Y.Andr e for valuable assistance.
This work was partly supported by the Swiss National Science Foundation.

References

- [1] F. Zernike, *Physica* **1**, 689 (1934).
- [2] C.Bourdelle et al., *Nucl. Fus.* **42**, 892 (2002)
- [3] M. Kotschenreuther et al., *Comput. Phys. Comm.* **88**, 128 (1995)