

Design Of An Off Grid Photovoltaic System: A Case Study Of Government Technical College, Wudil, Kano State

Ishaq M., Ibrahim U.H., Abubakar, H.

Abstract: Off-grid (stand-alone) photovoltaic (PV) systems have become widely adopted as reliable option of electrical energy generation. In this paper, the electrical energy demand (load) of the Government Technical College (GTC), Wudil Kano was estimated based on watt-hour energy demands. The estimated load is 48.787 kWh/ day. An off grid PV system was designed based on the estimated load. Based on the equipment selected for the design, 72 PV modules, 20 batteries, a voltage regulators and an inverter will be required to supply the electrical energy demand of the college. The proposed off-grid PV system requires copper wires of cross-sectional areas 1.22 mm², 32 mm² and 3 mm² for its installation. The cost estimate of the system ₦2 124 972 is relatively high when compared to that of fossil fuel generator used by the college. The payback period of the system is estimated to be 2.8 years, which is obviously much shorter than the lifespan of the selected PV modules which is 30 years.

Index terms: Photovoltaic System, Off-grid, Electrical Energy Demand, Cost Estimate, Payback Period

1.0 Introduction

The sun provides the energy to sustain life in our solar system. In one hour, the earth receives enough energy from the sun to meet its energy need for nearly a year [1]. Harnessing solar energy to power electrical appliances starts by converting the energy from the sun to electricity. Photovoltaic (PV) is the direct conversion of solar energy into electricity. PV systems can be used to exploit the solar energy in almost all applications. With fossil fuel resources expected to be depleted this century, PV Power systems provide a means of providing electricity to the developing world without concern for fuel supply security [2]. Today, more than 1.4 billion people all over the world lack access to electricity. About 42% of the people are from Sub-Saharan African, with over 76 million in Nigeria and some 69 million in Ethiopia and most of the rest in developing Asia [3]. Furthermore, 85% of these people live in rural areas. To improve access to electricity in the rural areas in Nigeria, a decentralized off-grid extension is considered in form of solar PV. An Off-grid PV Systems are systems which use photovoltaic technology only and are not connected to a utility grid. The systems use the DC output of the PV modules to power DC loads, while a bank of battery is used to store energy for use when there is demand.

The DC output of the batteries can be used immediately to run certain low DC Voltage loads such as lighting bulbs or refrigerators or it can be converted by an inverter to AC voltage to run AC-loads that constitutes most appliances. Off-grid PV system provides affordable electricity in area where conventional electricity grids are unreliable or non-existing. The geographical location of Government Technical College (GTC), Wudil makes it one of the relatively sun-reach remote regions on the globe. It is located in the northern part of Nigeria between latitude 11°45'N and 11°50'N and longitude 8°50'E and 8°55'E [4]. This implies that the solar panels must be mounted facing the south to capture the maximum amount of solar energy. The minimum peak sun-hours per day for GTC Wudil is 4.5 [4].

2.0 Methodology

The electrical appliances (loads) available at the college were first itemized with their power ratings and time of operation during the day to obtain the total energy demand in Watt-hour per day by the college. The total energy demand obtained was then used to determine the proposed off-grid photovoltaic system components sizes.

2.1 Load Estimation

The daily load profiles were determined by calculating the power demand (kWh/day) for all load types in the college. The estimated daily energy demand is given in Table 1.0 below. All the appliances used in the college are appliances.

- Ishaq Musa, M. Eng (Energy Engineering), Department of Mechanical Engineering, Bayero University, Kano, Nigeria., E-mail: ishagatuma@yahoo.com
- Ibrahim U. Haruna, M. Eng (Energy Engineering), Rank: Lecturer II, Department of Mechanical Engineering, Federal Polytechnic Mubi, P.M.B 35, Mubi, Adamawa State, Nigeria, E-mail: heldabuk@yahoo.com
- Abubakar Haruna, M. Eng (Energy Engineering), Rank: Technologist, Department of Mechanical Engineering, Bayero University, Kano, Nigeria

Table1.1 Estimated Daily Energy Demand for GTC Wudil.

Load	Rated power (W)	Quantity	Hours used per day	kW	kWh/day
Lighting bulbs	15	3	4	0.045	0.180
	20	1	4	0.020	0.080
	26	23	4	0.598	2.392
	32	13	4	0.416	1.664
	40	62	4	2.480	9.920
	85	3	4	0.255	1.020
	100	11	4	1.100	4.400
Refrigerator	100	1	8	0.100	0.800
Fans	50	2	5	0.100	0.500
	65	15	5	0.975	1.625
	70	50	5	3.500	17.500
Computers	125	15	4	1.875	7.500
Televisions	80	3	3	0.240	0.720
	81	2	3	0.162	0.486
Total				11.866	48.787

2.2 Selection of System Voltage

The system voltage is selected based on the requirements of the system. As a general rule the system voltage increases with increased daily load. However in a standalone PV system, the voltage is also dependent on the inverters that are available. When loads require ac power, the dc system voltage should be selected after studying available inverter characteristics. Since the total ac-load is greater than 5000W, the system voltage selected is 48vdc [5].

2.3 Selection of PV Module

In selecting a PV module for PV system, the main criteria are the performance warranty in case of any problems, module replacement ease; compliance with natural electrical and building codes and manual should be available to see the quality and characteristics of the module. The ENP Sonne High Quality 180Watt, 24V monocrystalline module is chosen in this design.

2.4 Determination of PV Array size

The PV array output power ($P_{PV\ array}$) can be determined by equation 1 [6][7][9].

$$P_{pvarray} = \frac{E_L}{\eta_{b.o} \times K_{Loss} \times H_{tilt}} \times PSI \quad (1)$$

E_L =Estimated average daily load energy consumption in

kWh/day

H_{tilt} = Average solar radiation in peak sun hour's incident for specified tilt angle.

PSI = Peak solar intensity at the earth surface (1kW/m²)

η_{bo} = Efficiency of balance of system

K_{Loss} =A factor determined by different losses such as module temperature, losses, dust, etc

$$\eta_{bo} = \eta_{inverter} \times \eta_{wire\ losses} \quad (2)$$

In this design $\eta_{inverter}$ and $\eta_{wire\ losses}$ are taken as 85% and 90% respectively [5][6].

$$\eta_{bo} = 0.95 \times 0.90 = 0.855$$

$$K_{Loss} = f_{man} \times f_{temp} \times f_{dirt} \quad (3)$$

Where,

f_{man} = manufacturer's tolerance

f_{temp} =Temperature de-rating factor

f_{dirt} = De-rating due to dirt if in doubt, an acceptable de-rating would be 5% [8]

f_{temp} , according to [8] is given by equation 4.

$$f_{temp} = 1 - [Y(T_{cell,eff} - T_{STC})] \quad (4)$$

Y = Power temperature co-efficient

$T_{cell,eff}$ = Average daily temperature in °C

$T_{cell,eff}$ can be determined by equation 5 [8]

$$T_{cell,eff} = T_{a.day} + 25 \quad (5)$$

Where,

$T_{a.day}$ = day time average ambient temperature in °C

The minimum peak sun hour per day (H_{tilt}) for Wudil is 4.5 [4]

The peak solar intensity (PSI) at the earth surface is 1KW/m²

From equation 4,

$$f_{temp} = 1 - [Y(T_{cell,eff} - T_{STC})]$$

Based on the manufacturer specification for the selected module, $T_{cell,eff} = 45^\circ C$,

$Y = 0.48\%/0C$, $T_{STC} = 250C$ and $f_{man} = 97\%$

$$f_{temp} = 1 - \left[\frac{0.48}{100} (45 - 25) \right] = 0.904$$

Since there is high rate of dustiness in GTC Wudil, f_{dirt} is taken as 95%.

From equation 3,

$$K_{Loss} = f_{man} \times f_{temp} \times f_{dirt}$$

$$K_{Loss} = 0.97 \times 0.904 \times 0.95 = 0.833$$

$$P_{pvarray} = \frac{48.787}{0.855 \times 0.833 \times 5.5} \times 1 = 13.0kW$$

2.5 Number of modules in series

The number of modules in series N_{ms} as given in equation 6 is determined by dividing the designed system voltage V_{system} (usually determined by the battery bank or the inverter) by the nominal module voltage V_{module} at Standard Test Condition [6]

$$N_{ms} = \frac{V_{system}}{V_{module}} \quad (6)$$

$$N_{ms} = \frac{V_{system}}{V_{module}} = \frac{48}{24} = 2modules$$

2.6 Number of modules in parallel

The number of modules in parallel N_{mp} as given in equation 7 is determined by dividing the designed array output $P_{pvarray}$ by the selected module output power P_{module} and the number of modules in series N_{ms} [6]

$$N_{mp} = \frac{P_{pvarray}}{N_{ms} \times P_{module}} \quad (7)$$

$$N_{mp} = \frac{13.0 \times 10^3}{2 \times 180} = 36modules$$

Total number of modules N_{mt} is given by equation 8 [10]

$$N_{mt} = N_{ms} \times N_{mp} = 2 \times 36 = 72modules \quad (8)$$

2.7 Determination of Battery bank capacity

The storage battery capacity can be calculated using equation 9 [9][10]

$$C_x = \frac{N_c \times E_L}{DOD_{max} \times V_{system} \times \eta_{out}} \quad (9)$$

Where,

C_x = Required battery capacity

N_c = Number of days of autonomy

E_L = Estimated load energy in Wh

DOD_{max} = Maximum depth of discharge

η_{out} = Battery loss

2.8 Determination of the required battery bank capacity

Batteries used in all solar systems are sized in ampere hours under standard test condition of 25°C. Battery manufacturers usually specify the maximum allowable depth of discharge for their batteries. The depth of the discharge is a measure of how much of the total battery capacity has been consumed. The minimum number of days of autonomy that should be considered for even the sunniest locations on earth is 5 days [12]. In this design the day of autonomy is taking as 4 days and the maximum allowable depth of discharge is taken as 75%. The battery bank capacity required (C_x) is given by;

$$C_x = \frac{N_c \times E_L}{DOD_{max} \times V_{system} \times \eta_{out}}$$

$$\eta_{out} = 0.85 \quad (\text{Leonics, 2009}), (\text{Sandia, 1995})$$

$$C_x = \frac{4 \times 48.787 \times 10^3}{0.75 \times 48 \times 0.85} = 6377 Ah$$

2.9 Specification of Battery type to be used

The battery selected is ROLLS SERIES 4000 BATTERIES, 12MD325P. The battery has a capacity of 325AH and a nominal voltage of 12V. From equation 10, number of batteries required (N_{breq}) is;

$$N_{breq} = \frac{C_x}{C_{selected}} \quad (10)$$

$$N_{breq} = \frac{6377}{325} = 20batteries$$

Number of batteries in series is given by equation 11

$$N_{bs} = \frac{V_{system}}{V_{battery}} \quad (11)$$

$$N_{bs} = \frac{48}{12} = 4batteries$$

Number of batteries in parallel is given by equation 12

$$N_{bp} = \frac{N_{breq}}{N_{bs}} \quad (12)$$

$$N_{bp} = \frac{20}{4} = 5batteries$$

2.10 Determination of Inverter size

In sizing the inverter, the actual power drawn from the appliances that will run at the same time must be determined as first step. Secondly, we must consider the starting current of large motors by multiplying their power by a factor of 3. Also to allow the system to expand, we multiply the sum of the two previous values by 1.25 as a safety factor [10].

$$P_{total} = (P_{RS} + P_{LSC}) \times 1.25 \quad (13)$$

Where,

P_{total} = Inverter power rating (size)

P_{RS} = Power of appliances running simultaneously

P_{LSC} = Power of large surge current appliances

The input rating of the inverter should never be lower than the total watt of appliances.

$$P_{total} = (P_{RS} + P_{LSC}) \times 1.25$$

In this design, $P_{LSC} = 0$

$$P_{RS} = 11.866kW \text{ from Table 1.0}$$

$$P_{total} = (11.866 + 0) \times 1.25 = 15kW = 15kVA$$

The inverter to be used for this system should have capacity not less than 15kVA and a nominal voltage of 48VDC.

2.11 Determination of Voltage Regulator Size

The voltage regulator is typically rated against amperage and voltage capacities. The voltage regulator is selected to match the voltage of PV array and batteries. A good voltage regulator must have enough capacity to handle the current from PV array. The rated current of the regulator is given by [10],

$$I_{rated} = N_{mp} \times I_{sc} \times f_{safety} \quad (14)$$

In this design, $f_{safety} = 1.25$ [5]

$$I_{rated} = 5 \times 5.38 \times 1.25 = 34 \text{ A}$$

The voltage regulator selected is Xantex C60 controller 60A, 12/24V. It has nominal voltage of 12/24VDC and charging load/current of 60 amperes. Number of voltage regulator required is given by equation 15.

$$N_{vreg} = \frac{I_{rated}}{I_{selected}} \quad (15)$$

$$N_{vreg} = \frac{34}{60} = 1 \text{ voltage regulators}$$

2.12 Determination of the System Cables Sizes

Selecting the correct size and type of wire will enhance the performance and reliability of photovoltaic system. The dc-wires between the photovoltaic modules and batteries through the voltage regulator must withstand the maximum current produced by these modules. This current is given by equation 14.

$$I_{rated} = N_{mp} \times I_{sc} \times f_{safety}$$

$$I_{rated} = 5 \times 5.38 \times 1.25 = 34 \text{ A}$$

The cross sectional area of the cable is given by equation 16.

$$A = \frac{\rho l}{V_d} \times 2 \quad (16)$$

ρ = resistivity of copper wire which is taken as $1.724 \times 10^{-8} \Omega m$ (AWG)

In both AC and DC wiring for standalone photovoltaic system the voltage drop is taken not to exceed 4% value [11]

2.13 Determination of Cable Size for PV Modules through the Batteries Voltage Regulators

$$\text{maximum voltage drop } V_{d} = \frac{4}{100} \times 24V = 0.96V$$

Let the length of the cable (l) = 1m

From equation 16,

$$A = \frac{\rho l}{V_d} \times 2$$

$$A = \frac{1.724 \times 10^{-8} \times 1 \times 34}{0.96} \times 2 = 1.22mm^2$$

This means any copper cable of cross sectional area $1.22mm^2$, 34 A and resistivity $1.724 \times 10^{-8} \Omega m$ can be used for the wiring between PV modules and batteries through the voltage regulator.

2.14 Determination of Cables Size between the Battery Bank and the Inverter

Let the length of the cable (l) = 5m

The maximum current from battery at full load supply is given by I_{max}

$$I_{max} = \frac{\text{Inverter kVA}}{\eta_{inverter} \times V_{system}} \quad (17)$$

$$= \frac{15kVA}{0.85 \times 48} = 358A$$

$$\text{maximum voltage drop } V_{d} = \frac{4}{100} \times 48 = 1.92V$$

$$A = \frac{1.724 \times 10^{-8} \times 5 \times 358}{1.92} \times 2 = 32mm^2p$$

This means any copper cable of cross sectional area of $32mm^2$, 358 A and resistivity $1.724 \times 10^{-8} \Omega m$ can be used for the wiring between the battery bank and the inverter.

2.15 Determination of Cable Size between the Inverter and the Load

Let the maximum length of cable (l) = 20m

The maximum current from inverter at full load on the phase (line) is given by

$$I_{phase} = \frac{\text{Inverter kVA}}{V_{output} \times \sqrt{3}} \quad (18)$$

$$= \frac{15kVA}{220 \times \sqrt{3}} = 40A$$

$$\text{maximum voltage drop } V_{d} = \frac{4}{100} \times 220 = 8.8V$$

$$A = \frac{1.724 \times 10^{-8} \times 20 \times 40}{8.8} \times 2 = 3mm^2$$

This means that any copper of cross sectional area $3mm^2$, 40A and resistivity $1.724 \times 10^{-8}\Omega m$ can be used for the wiring between the inverter and the load.

Table 1.2 Results Obtained from the Sizing of the Proposed Off-grid PV System

Component	Description of Component	Result
Load Estimation	Total Estimated Load	48.787 kWh/day
PV Array	Capacity of PV array	13 Kw
	Number of modules in series	2
	Number of modules in parallels	36
	Total number of modules	72
Battery Bank	Battery bank capacity	6377Ah
	Number of batteries in series	4
	Number of batteries in parallel	5
	Total number of batteries required	20
Voltage Regulator	Capacity of voltage regulator	34 A
	Number of voltage regulators required	1
Inverter	Capacity of the inverter	15 kVA
Wire	Between PV modules and batteries through voltage regulators	34A, 1.22mm ²
	Between battery bank and inverter	358A, 32 mm ²
	Between inverter and load	40 A, 3 mm ²

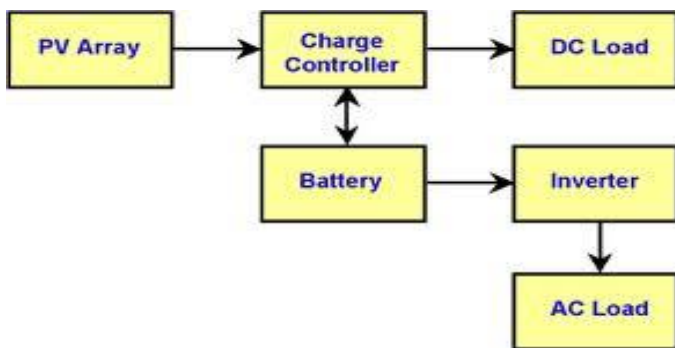

Figure 1. Block Diagram of the Proposed Stand-alone PV System

2.16 Cost Estimate of the System

The cost estimate of the system's components is summarized in Table 1.3

Table 1.3 Cost Estimate of the System's Components

Component	Model	Qty	Unit price (Naira)	Cost per component (Naira)
Modules	ENP Sonne 180W, 24V	72	20 000	1440 000
Batteries	ROLL12MD37 5P	20	15 000	300 000
Voltage Regulator	Xantrex C60	1	10 000	10 000
Inverter	SATCON 15kVA	1	12 000	12 000
SUBTOTAL				1762 000
Other BOS Costs (wires, fuses, circuit breakers, etc)				352400
TOTAL COST				2114 400

Cost per Component = Quantityx Unit price

Other Balance of System Component (BOS) Cost = 20% of subtotal [15].

The operating costs for solar PV installations are negligible, but the annual maintenance cost may amount to 0.5% to 1% of the capital cost of the system. Maintenance cost of the PV system = 0.5% of 2 114 400 = N10 572

Overall cost of the system= N2 114 400 + N10 572 = N2 124 972

2.17 Estimated Cost of the Fuel Generator used by Government Technical College Wudil.

The college has a 35kVA Caterpillar generator used to supplement power supply from the grid.

Hours used = 4 hours per day.

Total estimated hours used per annum = 4 x 365 = 1460 hours

Total estimated fuel (diesel) consumption per hour = 3 litres per hour

Total estimated fuel consumption per annum= 3 x 1460 = 4380 litres

Cost of diesel= N160 per litre

Total estimated cost of fuel used per annum = N160 x 4380 = N700 800

Total estimated cost of maintenance per annum = N10 000.00

Total running cost per annum = N 700 800 + N10 000 = N710 800

Cost of purchase of the fuel generator = N55 000

Total estimated cost of the fuel the generator for the first year = N710 800 + N55 000 = N765 800

2.18 Period

The payback period is given by [13] as:

$$\text{Payback Period} = \frac{\text{Overall cost of the PV system}}{\text{Total estimated cost of the fuel generator for the first year}}$$

$$\text{Payback Period} = \frac{N2\ 124\ 972}{N765\ 800} = 2.8\text{years}$$

3.0 Discussion

The daily electrical energy demand (load) for Government Technical College Wudil was estimated based on the watt-hour rating of the appliances considered. The results of the estimated daily energy demand are shown in Table 1.1. The estimated load is 48.787kWh/ day. The proposed off grid PV system was designed based on the estimated load. The results as shown in Table 1.2 show that Government Technical College Wudil requires 72 ENP Sonne 180W, 24V PV modules to produce a PV array capable of generating 13 kW of electrical energy for the college. The parallel and series configurations of the resulted PV array are 36 modules and 2 modules to produce the required current and voltage respectively (Table 1.2). For storage of energy for use when there is demand, the college requires 20 of ROLL12MD325P batteries of battery bank capacity 6377Ah which comprises 5 batteries in parallel and 4 batteries in series. To safely charge the batteries and to maintain longer lifetime for them, the college requires a voltage regulators of capacity 34 A. The capacity of the inverter required by the proposed system to convert its DC current to AC current is 15 kVA. The resistivity of the copper wire selected for this design is $1.724 \times 10^{-8} \Omega$. The DC wires between the PV modules and batteries through the voltage regulators must withstand the maximum current produced by these modules. This current is 34 A, and the optimum wire type for this current is any copper wire of cross sectional area 1.22mm². The DC wire between the batteries and the inverter must withstand the maximum current from battery at full load supply. This current is 358 A, and any copper wire of cross sectional area 32 mm² can be use. The AC wire from the inverter to the load must withstand the maximum current produced by the inverter. This current is 40 A, and the optimum wire type for this current is any copper wire of cross sectional area 3mm². It can be observed from Table 1.3 that the modules and the batteries are the two most costly components of an off grid photovoltaic system. Increasing the size of these components will increase the overall cost of the system. A cost estimate of the system provided in Table 1.3 shows that the initial cost of the system (N2 124 972) is relatively

high but the payback period of the system is estimated to be 2.8 years, which is obviously much shorter than the lifespan of the selected PV modules for this design which is 30 years [14].

4.0 Conclusions

In this paper, the electrical energy demand (load) of Government Technical College Wudil was estimated. The estimated load is 48.787kWh/ day. System sizing and specifications were provided based on the estimated load. The results show that a 13kW PV array capacity of 72 modules, 20 (12V, 325Ah) batteries, a 15kVA, 48V inverter and a 60A, 24V voltage regulator are needed to supply the electrical load of the college. The proposed off grid PV system requires copper wires of cross-sectional area 1.22mm², 32 mm² and 3 mm² for its installation. The cost estimate of the of the system N2 124 972 is relatively high when compared to that of fossil fuel generator used by the college but the payback period of the system is estimated to be 2.8 years, which is obviously much shorter than the lifespan of the selected PV modules which is 30 years. The recommendation would be that the system can be made utility- interactive to enable the purchase of surplus solar energy from users.

References

- [1]. Messenger and Jerry Ventre, 2000. Photovoltaic System Engineering. CRC Press.
- [2]. IEA-PVPS 2000
- [3]. Muhammad Modibbo, "Improving Energy Access: Costs and Benefits of Solar PV in Nigeria". An Article Published by The Mix: Oil and Water, January 23, 2012.
- [4]. Geographical Information System, Kano University of Science and Technology (GIS, KUST), Wudil
- [5]. Sandia, (1995), "Stand-Alone Photovoltaic Systems: A Handbook of Recommended Design Practices", Sandia National Laboratories Albuquerque New Mexico. PP:1-B53
- [6]. Friedrich Sick and Thomas Erge, (1996) "Photovoltaic's in Buildings-A Design Handbook for Architects and Engineers", Frieberg Germany.
- [7]. Ahmad G E (2002), "Photovoltaic – powered Rural Zone Family House in Egypt", Renewable Energy, Volume 26, PP: 379-390.
- [8]. Clean Energy Council (CEC), "Grid Connected PV Systems Design Guidelines for Accredited Designers" Issue 3 July 2007, Update November 2009.
- [9]. Leonics Company Ltd, (2009), "How to Design PV Systems" www.leonicsolar.htm
- [10]. Assad Abu-Jasser, (2010), "A Stand Alone Photovoltaic System, Case Study: A Residence in Gaza", Journal of Applied Sciences in

Environmental Sanitation. Vol.5, PP:81-91

- [11]. National Electrical Code (NEC, 2005)
- [12]. Sun Xtender Batteries, 2009, San Bernardino Road West Covina, CA, 91790 USA
www.sunxtender.com
- [13]. Raja Rajeswari L., Krishna Bhanu C. V. "Design of Stand-Alone Photovoltaic System"International Journal of Engineering Research and Applications (IJERA) ISSN: 2248-9622 www.ijera.com Vol. 3, Issue 2, March -April 2013, pp510-515
- [14]. ENPSonne 180 W,24 V PV Module Manufacturer's Manual
- [15]. CaishengWang, and M. Hashem Nehrir, (2008) "Power Management.