

## Design of Measurement Memory System Based on MEMS Acceleration Sensor

<https://doi.org/10.3991/ijoe.v14i09.8689>

Lei Xu, Liqing Fang<sup>(✉)</sup>, Xu Li, Ruikun Huo, Deqing Guo, Ziyuan Qi  
Mechanical Engineering College, Shijiazhuang, China  
fangliqingxl@163.com

**Abstract**—With the rapid development of MEMS technology, MEMS acceleration sensors have been used more and more widely due to their unique advantages. Taking MEMS acceleration sensor as the core device, a measurement memory system was designed. The system mainly included acceleration detection module, acceleration memory module and control display module, which could realize real-time acceleration measurement and memory, and uploaded the stored data to the computer. The vibration test was used to detect the performance of the system. Result showed that the system could achieve the desired effect, and realize real-time acceleration measurement and memory within the allowable error range. The system possessed strong resistance to high overload capacity, which could still work normally under the condition of the maximum overload of at least 100g.

**Keywords**—MEMS technology; MEMS acceleration sensor; measurement-memory system

### 1 Introduction

The MEMS (Micro Electro-Mechanical System) technology refers to a micro-fabrication process, which integrates micro-sensors, micro-actuators, micro-motion mechanisms, signal detection circuits, and control execution circuits, even power, interfaces, and communications[1].The rapid development of integrated circuits and processing technology have also promoted the rapid popularization and promotion of MEMS technology. Sensors fabricated using MEMS technology have many advantages such as low power consumption, light weight, low cost, and high sensitivity[2].Along with continuous development of sensor technology., as one of the important branches of MEMS sensors, MEMS acceleration sensors have been more and more widely used in various fields [3-6]. The process of combining data , which consisted of micro inertial measurement based on MEMS acceleration sensors, was simple, intuitive, reliable. This process did't have to change the structure of the missile structure, which was of great significance for expanding the scope of its application [3]. In the design of indoor navigation systems, the acceleration sensor was the core sensitive device, which had the characteristics of low cost and small size [7]; In the field of high-overload penetrating munitions, high-g-value accelerometers had been

successfully developed in many aspects, and the maximum overload could reach 200000 g. Using this accelerometer could achieve the penetration depth control, which would be greatly promoted in drilling munitions [8]. Although application range of the acceleration sensor was expanding, due to the limitation of the technical level, practical application which used MEMS acceleration sensor as the core design still remains low [9-10].

Acceleration, velocity and displacement were important indicators of the motion characteristics of objects. Obtaining these signals was of great significance for evaluating the functional properties of an object and grasping the state of the moving object at all times [11-12]. Compared with the acceleration signal, displacement signal and velocity signal were more difficult to obtain accurately in engineering practice [13-16], but the mathematical calculus relationship between acceleration, velocity, and displacement was also relatively clear. It was possible to indirectly obtain displacement and velocity of an object by using the calculus relationship between acceleration, velocity, and displacement. Using MEMS acceleration sensor to measure the motion characteristics of an object had unique advantages.

MEMS is a newly developed technology. The application of MEMS accelerometers in engineering is still rare. The use of wireless sensors is a trend in the development of online engineering. This paper took wireless MEMS acceleration sensor as core and designed a measurement system that could measure and store the acceleration of a moving object in real time. Designs of hardware and software engineering and computer communication were completed, and the application of MEMS technology and sensor technology was realized in the field of online engineering. Firstly, Overall designs of the hardware circuit and software were introduced. And two kinds of error evaluation indexes were defined, Then three modules of the system were described in detail. The system used an accelerometer based on the principle of thermal convection. There were no moving parts inside the sensor which could resist high overload. At last, The performance of the system was tested through vibration experiment. The result showed that system had high anti-overload capability, and acceleration could be measured and stored within the range of accuracy. Using the reliable data, Velocity and displacement can be calculated. Of course, it's also necessary to be optimized in various aspects such as ambient temperature, sensor zero drift and so on. The system could realize accurate measurement of acceleration and provide important data support for distance measurement and inertial navigation. Since its overload resistance was at least 100g, it was suitable for most of the consumption fields and could also be used for mechanical fault diagnosis. The realization of the circuit system design provided reference for the application of the sensor in the online engineering. It was of great practical significance to combine the MEMS and sensors in the online engineering design.

## 2 Overall Design of the Measurement Memory System

### 2.1 Overall Design of the Hardware Circuit

In the measurement memory system, the functions to be implemented include acceleration signal detection, acceleration signal storage, and acceleration signal upload. In order to realize the corresponding functions, the system is divided into three modules: acceleration detection module, acceleration storage module, and control display module. The overall block diagram of the system is shown in figure 1.

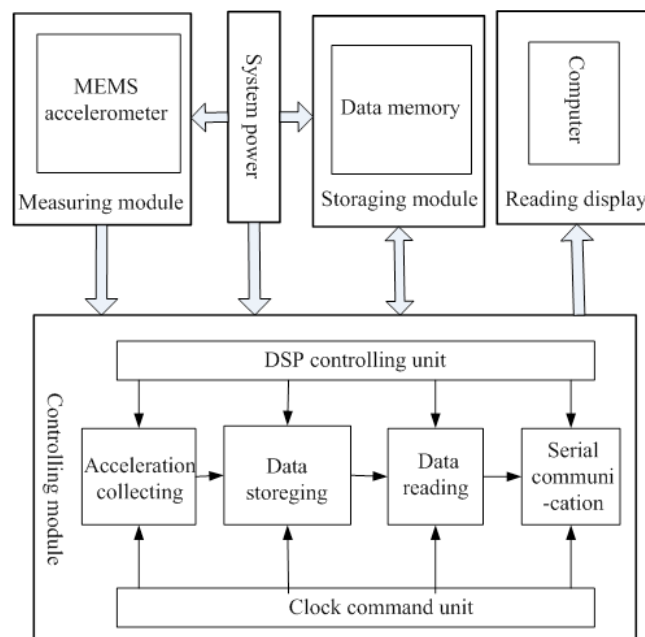
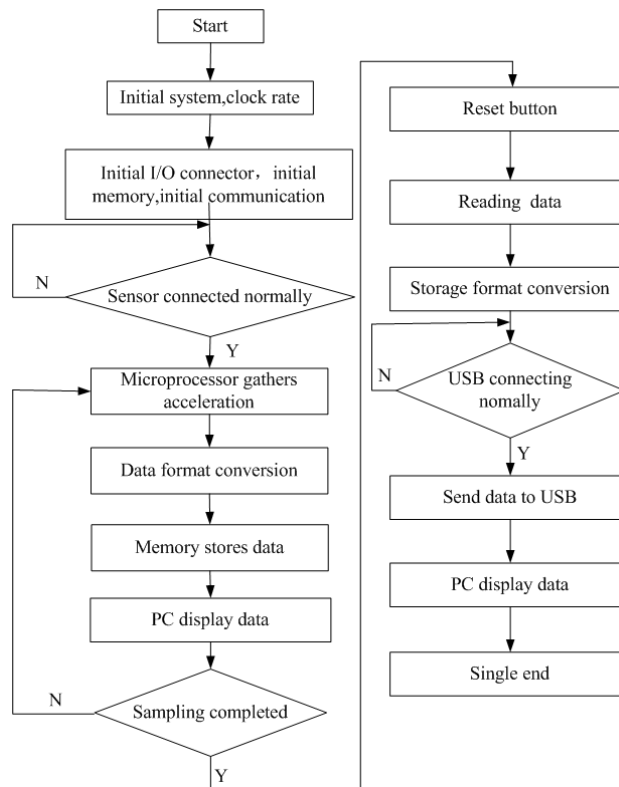

Fig. 1. Overall block diagram of the measurement memory system

In the measurement memory system, the system power is supplied by dual power modes. The external power voltage is 3v, the external voltage is adjusted to 3.3V through the power conversion chip, which is used by the acceleration detection module, the acceleration storage module, and the control display module. The 1.8V voltage required by the display module is provided by the microprocessor itself. The acceleration detection module is responsible for measuring the original acceleration data in real time and uploading it to the microprocessor in a fixed format; the control display module receives the acceleration data of the detection module and performs format conversion. Acceleration data converted is transmitted to the acceleration storage module; storage module stores the data transmitted by the control display module in sequence. When the computer and the control display module are connected normally, the stored data is visually displayed in the computer.

## 2.2 Overall Design of Software

Objects controlled by the measurement memory system designed with MEMS acceleration sensor as the core include I2C data acquisition, SPI data storage, and SCI data transmission. The software flow chart is shown in figure 2. When the system is powered on, the microprocessor first initializes each module, which mainly includes the initialization of the microprocessor, memory, sensors, and communication unit. After the initialization, the acceleration sensor starts to detect the acceleration of the object, and sends the data to the microprocessor. The microprocessor checks the connection status of the acceleration sensor. When the connection is normal, the accelerometer signal supplied by the sensor is received, and the format is converted. The data will be collected accordingly. Acceleration data is sequentially stored in a ferroelectric memory. The vibration module is directly connected to the computer while the vibration tester is in vibration. When the microprocessor stores data, the data measured by the sensor is also displayed in the computer. After a period of vibration, the process is judged. Whether the sampling is completed, press the reset button after the sampling is completed. At this time, the acceleration data of the storage module will be uploaded to the computer in a fixed format. After transporting successfully, the power is turned off and the measurement storage system stops working.



**Fig. 2.** Program flow chart

The microprocessor uses DSP which possesses advantage of digital processing. In order to make full use of digital processing capabilities of DSP, maximize the acquisition frequency of the acceleration sensor in the vibration process, meet the requirements of real-time measurement and storage in the measurement memory, the system adopts data stream processing to collect and process acceleration signals. After the completion of an acquisition, the acceleration data is sequentially stored immediately. it needs to be ensured that the acceleration sensor will not generate acceleration data before completing storage. Since the data stream processing method can be stored and implemented within the sampling period of the sensor, the system delay can be minimized, so acceleration sensor can reach the maximum acquisition frequency, which is conducive to improving the measurement accuracy .

### 2.3 Error Evaluation Criteria

For the acquired acceleration signal, MATLAB simulation can be used to fit the waveform of the vibration acceleration change. Through comparing measuring curve with the waveform diagram of the vibration test bench, it can be seen intuitively that the measured acceleration of the storage system coincides with the output acceleration of the test stand. However, in order to quantitatively analyze the measurement results, there must be corresponding indicators for error evaluation. In this paper, the performance of the measurement storage system is evaluated by using three error evaluation parameters, namely the sum-squared error, the average maximum relative error, and the average peak error.

To evaluate two waveforms, we must first examine the overall effect of different waveforms, that is, to evaluate the energy difference of the waveforms. Therefore, the sum of squared error is introduced to describe the energy difference between the output signal of the shaking table and the actual measurement signal.

$$Erqs = \frac{\sum_{i=1}^N [b(i)]^2 - \sum_{i=1}^N [a(i)]^2}{\sum_{i=1}^N [a(i)]^2} \quad (1)$$

In the formula, b(i) represents the actually measured acceleration signal, a(i) represents the shaking table output signal, and N represents the sampling point [16].

To evaluate two waveforms in comparison, it is necessary not only to examine the overall effect of the waveform but also to pay attention to the difference in the peak value of the waveform. The average maximum relative error is the average of the positive and negative peaks of the relative error time [b(t)-a(t)] with respect to the positive and negative peaks of a(t), respectively.

$$Err = \frac{1}{2} \left\{ \frac{|\max[b(t) - a(t)]|}{|\max[a(t)]|} + \frac{|\min[b(t) - a(t)]|}{|\min[a(t)]|} \right\} \quad (2)$$

The average peak error is the average of the errors of the positive and negative peaks of the acceleration time  $b(t)$  with respect to the positive and negative peaks of the  $a(t)$  of the vibration table.

$$Errp = \frac{1}{2} \left\{ \frac{|\max[b(t)] - \max[a(t)]|}{|\max[a(t)]|} + \frac{|\min[b(t)] - \min[a(t)]|}{|\min[a(t)]|} \right\} \quad (3)$$

### 3 Design of Hardware Circuit

#### 3.1 Design of Acceleration Measurement Module Circuit

The module design uses a MEMS acceleration sensor MXC4005xc. This sensor is based on the thermal sensing technology proposed by MTS Semiconductor and uses a wafer level packaged miniature sensor. There are no mechanical parts that can be moved inside the sensor, and it has good anti-vibration and anti-impact ability. Under the condition of 200000g, the sensor can still work normally. This module circuit schematic is shown in Figure 3. The sensor data transmission interface adopts I2C bus mode to output 12-bit valid data and upload it to the processor in two's complement form. It also provides I2C fast reading operation. An INT pin is provided in the sensor to facilitate the direction of movement and X/Y jitter detection. I2C bus can connect multiple acceleration sensors to one processor to process the test data at the same time which is in favor of improving the measurement accuracy. In the measurement memory system, the data flow processing method is adopted to collect and process the acceleration signal. After one acquisition completed, acceleration data are sequentially stored immediately, and it is ensured that the accelerometer does not generate acceleration data before the storage ends. System delay is minimized, the accelerometer reaches the maximum acquisition frequency.

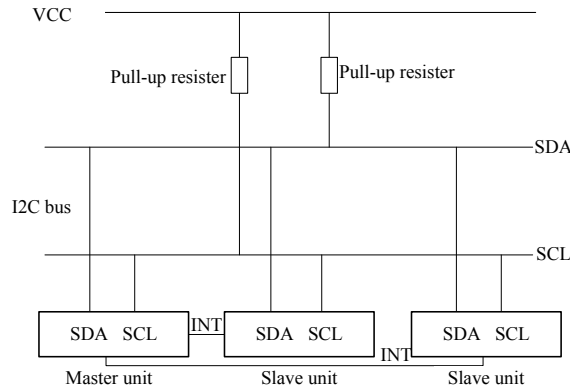

Fig. 3. Circuit schematic of acceleration measurement module

### 3.2 Design of Acceleration Memory Module Circuit

The memory module utilizes the ferroelectric memory FM25V20A, which is recent introduction of a non-volatile memory that combines low power consumption and high performance in Ramtron. The stored data is not lost after power down, which not only overcomes the shortcomings of long writing time of EEPROM, and low erasure of FLASH, but also costs much lower than other non-volatile SRAMs. The circuit schematic is shown in figure 4. The processor and ferroelectric memory are connected by using a SPI (Serial Peripheral Interface) bus, in which a master device is connected to a plurality of slave devices. A four-wire communication method is used, which includes: SCLK clock, CS slave device Select, MISO master input slave output, and MOSI master output slave input. The controller determines the ferroelectric memory using the CS pin, writes read data commands to the MEMS acceleration sensor through the MOSI, and reads the output acceleration of the MEMS acceleration sensor from the MISO port, and provides an external clock signal for the MEMS acceleration sensor through the SCLK port.

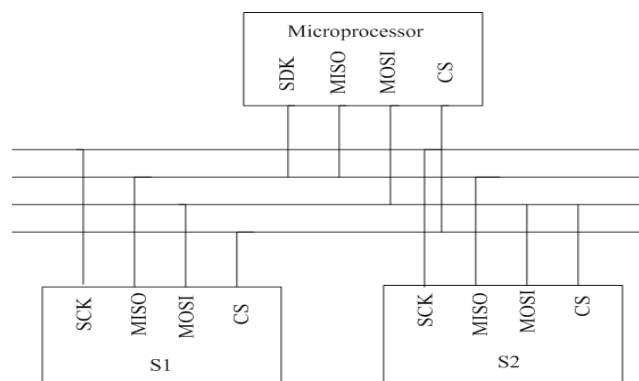

Fig. 4. Circuit schematic of acceleration memory module

### 3.3 Design of Control Display Module Circuit

The control display module includes a storage unit and a communication unit, completes real-time reading and storage of the acceleration, and uses the serial communication circuit to upload the data to the computer. This module uses a microprocessor DSP (Digital Signal Processor) which is capable of high-speed digital signal processing operations. DSP adopts the Harvard structure, has independent program space and data space, whose program space and data space access simultaneously through an independent data bus. Built-in high-speed multipliers and enhanced multi-stage pipelines enable high-speed data processing capabilities. The DSP also provides highly specialized instruction sets that increase the speed of operation. The characteristics of the DSP greatly increase its computing power and processing power, so that it can well meet the requirements for fast, accurate, real-time processing and control of signals.

The communication unit realizes the communication between system and computer which uploads the acceleration data stored in the ferroelectric memory into the computer. As is shown in Figure 5, DSP uses a serial interface circuit to achieve communication with the host computer. This communication method has less data lines and can save costs in long-distance communication. At the same time, SCITXDA and SCIRXDA realize the data sending and receiving respectively, which make transmission speed faster. The serial interface circuit design is implemented using the common RS-232 (ANSI/EIA-232 standard) serial connection standard. The hardware design directly connects the serial port to the USB circuit. No matter encoding mode or the level conversion, it can meet the requirements of using. Therefore, there is no need for excessive support for software programming, and the processing speed of the processor is increased.

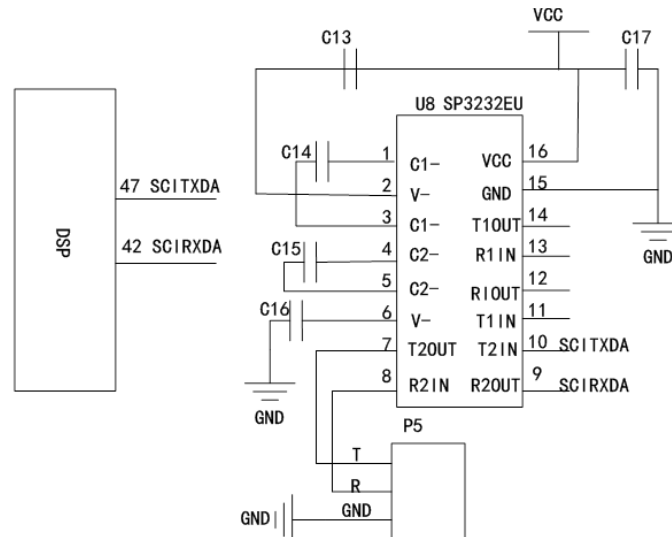

Fig. 5. Circuit schematic of the communication unit



The circuit board of the system is shown in figure 6, power connector provides voltage for the whole system through connecting external power; communication connector realizes real-time reading display and storage display of acceleration data. In order to ensure the normal operation of the circuit system, measure the working status of the circuit board accurately, test holes are provided in the circuit board to facilitate the detection of the output signal. Two data storage display, the real-time acceleration measurement data unconverted and the data converted from ferroelectric memory. When the two pieces of data are consistent, it indicates that the measurement memory system is working properly. Then the data uploaded to the computer is analyzed, and the measurement accuracy of the measurement storage system is tested.

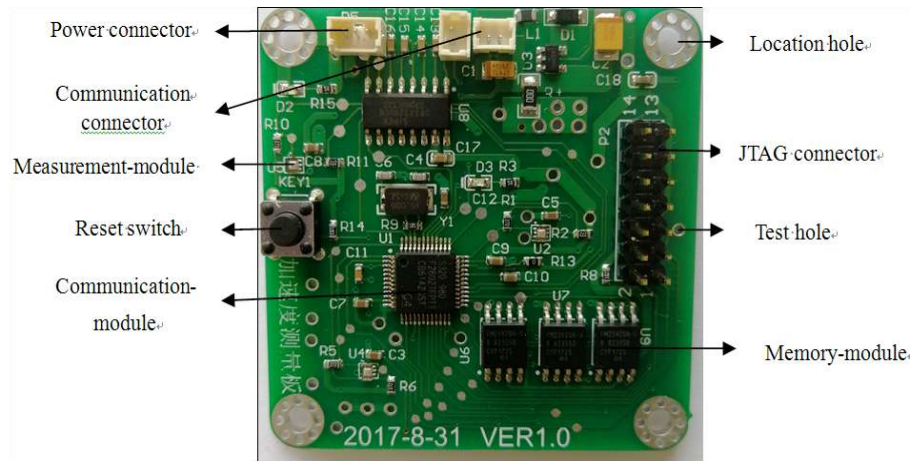

Fig. 6. Printed circuit board

#### 4 Design of Vibration Test

As was shown in figure 7, in order to realize the rigid connection between the measurement system and the vibration test stand, the measurement system was fastened to the load-bearing plate. The load-bearing plate and the vibration test stand were screwed. The actual output acceleration during vibration of test stand was the axial acceleration of the shaking table. To ensure that the direction of the vibration acceleration was consistent with the sensing direction of the sensor, the lateral error of the measurement storage system was reduced, and the level of the lateral deflection of the test vibration test stand was measured using a level gauge. Then the level was placed on the surface of measurement memory system. The load-bearing plate was adjusted make the angle of the side-offset of the measurement memory system same as the side-angle of the vibration test. So that the side-to-side value in the horizontal direction was reduced. Test steps includes: set the vibration test stand to output two accelerations that observe sine law, uploaded the test data, set the maximum output value of the acceleration tester of the vibration tester to reach 50g, 80g, and 100g to perform

the test of high overload resistance, then set the vibration test stand outputs measurable acceleration data. Through observing the LED lights flicker, observing data display interface data characteristics, and outputting upload acceleration data, analyzing the data output curve, the working status of the measurement system was determined.

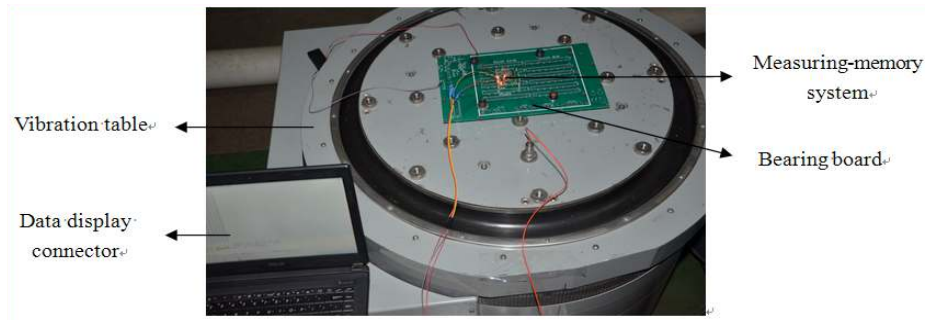

Fig. 7. Design of vibration test

## 5 Results and Analysis

There were two groups of data uploaded to the computer. One group was real-time measurement and uploading data, the storage format of which was not converted. The other group was the data that was stored in ferroelectric memory. Both sets of data were presented as binary values. The form of the complement code was uploaded. The original data was shown in Table 1, and the second set of acceleration data was processed using MATLAB.

Table 1. Results of vibration test

Real-time measurement data original value	Real-time measurement data actual value	Original data in storage system
0xb6 0x07	0b67H	0b67H
0xca 0x0e	0caeH	0caeH
0xa8 0x07	0a87H	0a87H
0xb7 0x0c	0b7cH	0b7cH
0xc8 0x0e	0c8eH	0c8eH
0xe5 0x08	0e58H	0e58H
0xec 0x0a	0ecaH	0ecaH
0xc6 0x07	0c67H	0c67H
0xb6 0x0a	0b6aH	0b6aH

The output of the vibration test stand was set to make the accelerations obey  $a=6.8-2 \times \cos(t \times 2.5)-3.5 \times \sin(t \times 2.5)$  and  $a=3.3+\cos(t \times 2)+0.2 \times \sin(t \times 2)$ . The standard output curves were shown in Figure 8 (a, b), and the measured values in the measurement memory system were shown in Figure 9 (a, b).

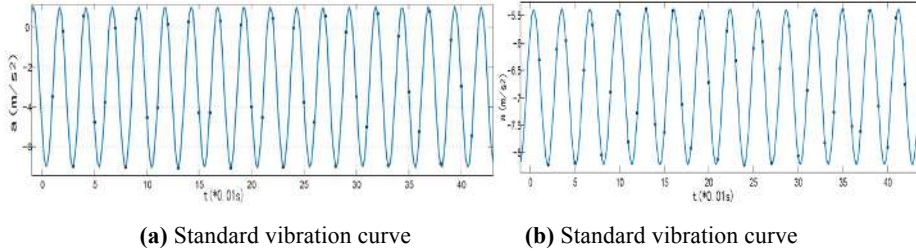

Fig. 8.

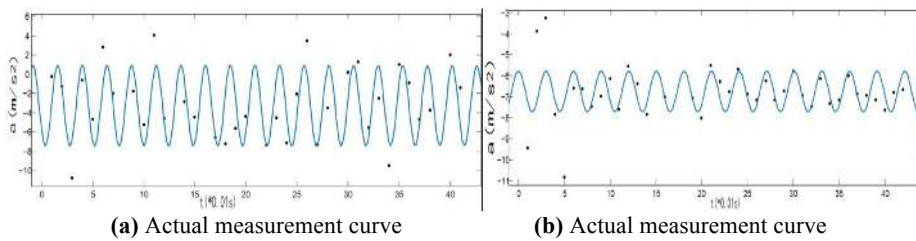

Fig. 9.

The obtained data were fitted by using MATLAB curve fitting tool. The fitted curves obey respectively  $a = -3.061 - 2.092 \times \cos(i \times 2.504) - 3.494 \times \sin(i \times 2.504)$ ,  $a = -6.545 + 0.9701 \times \cos(i \times 2.086) + 0.48 \times \sin(i \times 2.086)$ . Due to the influence of gravity acceleration during the vibration test, the acceleration of gravity should be added to the fitting function. The function after adding gravity acceleration was shown in Table 2.

Table 2. Comparison table of output function and measurement function of vibration test stand

Test stand output function	Function added gravity acceleration	Measurement function
$a = 6.8 - 2 \times \cos(t \times 2.5) - 3.5 \times \sin(t \times 2.5)$	$a = -3 - 2 \times \cos(t \times 2.5) - 3.5 \times \sin(t \times 2.5)$	$a = -3.061 - 2.092 \times \cos(i \times 2.504) - 3.494 \times \sin(i \times 2.504)$
$a = 3.3 + \cos(t \times 2) + 0.2 \times \sin(t \times 2)$	$a = -6.5 + \cos(t \times 2) + 0.2 \times \sin(t \times 2)$	$a = -6.545 + 0.9701 \times \cos(i \times 2.086) + 0.48 \times \sin(i \times 2.086)$

The evaluation performance of the acceleration measurement storage system was evaluated by the proposed error evaluation index in section 2.3. ‘Function added gravity acceleration’ and ‘Measurement function’ corresponded to ‘a’ and ‘b’ independently. The sum-squared error, the average maximum relative error and the average peak error were calculated by equations (1),(2),(3) independently. The specific results were shown in Table 3.

**Table 3.** Error Analysis of Acceleration Measurement

	The sum-squared error%	the average maximum relative error %	the average peak error %
First vibration test	1.5	1.04	1.37
Second vibration test	2.6	2.78	0.68

From Table 1, it could be seen that the two sets of data were identical, which indicated that the measurement memory system worked normally, and that acceleration measurement and storage could be performed; from the comparison of the output function and the output curve, it could be found that the measurement memory system could basically and accurately measure the variation trend of vibration test. From Table 3, it could be seen that the accuracy of the acceleration measurement of the acceleration measurement storage system was high, and data support could be provided for speed calculation and displacement calculation within the allowable error range, which could meet the needs of the actual project. When carrying out the anti-overload capability test of the vibration test stand, the maximum acceleration of the vibration test stand was adjusted to 50g, 80g, 100g for two minutes, followed by  $a=3+0.4\times\cos(t\times 2)-0.5\times\sin(t\times 2)$ . The test results of the measurement memory system were shown in FIG. 10.

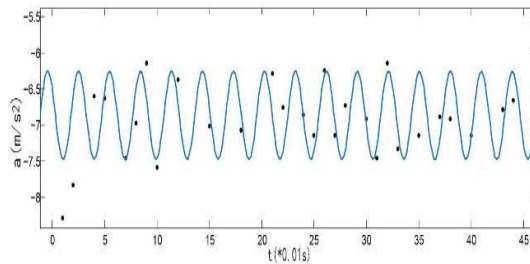

**Fig. 10.**Measuring Vibration Curve

From the vibration curve and the LED flashing status, it could be judged that the measurement memory system could still work normally, and system could resist a high overload.

## 6 Conclusion

In this paper, a measurement memory system based on the MEMS acceleration sensor was designed, which included three modules.. The acceleration measurement module measured the acceleration of the moving object in real time. The acceleration memory module stored the measured acceleration data. The control display module uploaded the data to the computer. Through the comparison of the data displayed twice, it was found that the system could work normally and achieved the desired function. The high g value vibration test found that the measurement system had the

ability to resist high overload. Under the condition of at least 100g, the measurement memory system was basically free from damage and could still work normally. It could be used under high-speed impact environmental conditions. The performance of the MEMS acceleration sensor in the measurement memory system was stable. By comparing with the actual output curve of the vibration experiment, it was found that the system could basically and accurately measure the vibration acceleration and meet the requirements of engineering applications within the allowable error range. It could provide reliable data for the calculation of velocity and displacement. But the system was affected by installation errors, ambient temperature, and sensor zero drift during the test. Of course, these parameters can all be further processed. For example, the installation errors can be reduced by optimizing the processing technology, the temperature control test can be used to obtain the influence law of temperature on the system, and the zero-drift of the system can be determined by the turntable test. Through various measures, the system can be further optimized.

## 7 References

- [1] Chakraborty A, Gupta B. (2016) Development of compact 180° phase shifters based on MEMS technology [J]. *Sensors & Actuators A Physical*, 247:187-198. <https://doi.org/10.1016/j.sna.2016.05.046>
- [2] WANG J, JIANG X J, ZHANG L, et al. (2015) . Design and fabrication of energetic superlattice like-PTFE/Al with superior performance and application in functional micro-initiator [J] *Nano Energy*, 12: 597–605. <https://doi.org/10.1016/j.nanoen.2014.12.016>
- [3] Xu R, Ghou S, Li WJ.(2012). MEMS accelerometer based nonspecific-user hand gesture recognition [J].*IEEE Sensors Journal*,12(5):1166-1176. <https://doi.org/10.1109/JSEN.2011.2166953>
- [4] Merz, P.;Reimer, K.;Weiss, M. et al.,Combined MEMS inertial sensors for IMU applications, 2010 IEEE 23rd International Conference on Micro-Electro-Mechanical Systems (MEMS), Jan 24-28, 2010, Wanchai, Hong Kong, pp:488-491 .
- [5] Peter S, Hubert G.(2012). State estimation on flexible robots using accelerometers and angular rate sensors [J]. *Mechatronics*,22(8):1043-1049. <https://doi.org/10.1016/j.mechatronics.2012.08.009>
- [6] Han Ying Dang, Li Zhe.(2015). Data Acquisition and Preprocessing of MEMS Acceleration Sensors [J]. *Instrumentation Technology and Sensors*,2:16-19.
- [7] Wen Feng, Shi Yunbo, Zhou Zhen, et al.(2013). High-g-value accelerometer based on MEMS and its application in projectile penetrating double-layer steel target test[J]. *Journal of Vibration and Shock*, 32(19):165-169.
- [8] Beravs T, Podobnik J, Munih M.(2012). Three axial accelerometer calibration using kalman filter covariance matrix for online estimation of optimal sensor orientation[J].*IEEE Transactions on Instrumentation and Measurement*,61(9):2501-2511. <https://doi.org/10.1109/TIM.2012.2187360>
- [9] WANG Dai-hua,Yuan Gang. (2011). A six-degree-of-freedom acceleration sensing method based on six coplanar single-axis accelerometer[J].*IEEE Transactions on Instrumentation and Measurement*,60(4):1433-1442. <https://doi.org/10.1109/TIM.2010.2083331>
- [10] Lin P C, Lu T C , Tsai C H, et al.(2012). Design and implementation of a nine-axis inertial measurement unit[J]. *IEEE/ASME Transactions on Mechatronics*,17(4):657-668.

- [11] Wan Zhen, Cui Feng, Zhang Weiping, et al. Design of proof mass and system-level simulation of a micromachined electrostatically suspended accelerometer[C].2011 International Conference on Advanced Design and Manufacturing Engineering Guangzhou, China. pp:1631-1634.
- [12] Dongjun Hyun, Minsu Jegal. Compact Self-contained Navigation System with MEMS Inertial Sensor and Optical Navigation Sensor for 3-D Pipeline mapping[C]. International Conference on Intelligent Robots and Systems,2010,Taibei,pp:1488-1493.
- [13] Xu R Z, Zhou S L, Li W J. (2012). MEMS Accelerometer Based Nonspecific-User Hand Gesture Recognition[J]. IEEE Sensors Journal,12(5):1166-1173. <https://doi.org/10.1109/JSEN.2011.2166953>
- [14] Young D J, Zurcher M A, Semaan M, et al.(2012). MEMS Capacitive Accelerometer-Based Middle Ear Microphone[J]. IEEE Transactions on Biomedical Engineering,59(12):3283-3292. <https://doi.org/10.1109/TBME.2012.2195782>
- [15] Li Jie, Zhao Wei, Liu Jun, et al.(2013). Semi-strapdown MEMS inertial measurement device for high-spinning ammunition flight attitude measurement[J]. Acta Metallurgica Sinica, 34(11):1398-1403.
- [16] Wen Guangrui ,Li Yang, Liao Yuhe, et al. (2013). Faulty rotor system vibration acceleration signal integration method based on precise information reconstruction [J] . Journal of Mechanical Engineering ,49(8):1-9. <https://doi.org/10.3901/JME.2013.08.001>

## 8 Authors

**Lei Xu (First author)** is a master student in Mechanical Engineering College, Shijiazhuang, China. His main research direction is mechanical testing technology. (Email:xldxulei@163.com).

**Liqing Fang** is a professor in Mechanical Engineering College, Shijiazhuang, China. His main research direction is the mechanical performance testing and fault diagnosis technology. (Email:fangliqingxl@163.com).

**Xu Li** is a master student in Mechanical Engineering College, Shijiazhuang, China. His main research direction is mechanical testing technology.

**Ruikun Huo** is a master student in Mechanical Engineering College, Shijiazhuang, China. His main research direction is mechanical testing technology.

**Deqing Guo** is an associate professor in Mechanical Engineering College, Shijiazhuang, China. His main research direction is mechanical fault prediction technology.

**Ziyuan Qi** is an associate professor in Mechanical Engineering College, Shijiazhuang, China. His main research direction is mechanical fault prediction technology.

Article submitted 06 April 2018. Resubmitted 03, 27, and 29 May 2018. Final acceptance 31 May 2018. Final version published as submitted by the authors.