

# DESIGN OF SEQUENTIALLY FED BALANCED AMPLIFYING ANTENNA FOR CIRCULAR POLARIZATION

S. K. Behera<sup>1</sup>, D. R. Poddar<sup>2</sup> and R. K. Mishra<sup>3</sup>

<sup>1</sup>Department of Electronics & Communication Engineering, National Institute of Technology, Rourkela, India  
E-mail: skbehera@ieee.org

<sup>2</sup>Department of Electronics & Tele-Communication Engineering, Jadavpur University, Kolkata, India  
E-mail: drp\_ju@yahoo.com

<sup>3</sup>Department of Electronic Science, Berhampur University, Orissa, India  
E-mail: prof.r.k.mishra@gmail.com

## Abstract:

*This paper presents a sequentially fed balanced amplifying antenna that exhibits circularly polarized radiation. The inherent benefits of good isolation between input and output ports as well as improved matching capabilities of balanced amplifiers provide overall system gain of 8 dBi at frequency 2.36GHz. The planar arrangement of the patch antenna elements are considered to form an array. The phase of the feeding in the array increases progressively from 0° to 270°. Each element in the array is linearly polarized. Here four elements were considered and arranged at the four corners of a square domain. This arrangement shows that each antenna sees its adjacent ones to be radiating from an edge orthogonal to its edge of radiation. Circular polarization is achieved due to this sequential feeding. This array is designed with operating frequency 2.4 GHz. A good axial ratio of 2.4 is obtained at 2.37 GHz frequency. The noise figure is considerably reduced and which is around -19dB.*

## Keywords:

*Sequentially Fed, Circular Polarization, Balanced Amplifying Antenna, Array*

## 1. INTRODUCTION

The balanced amplifying antenna is suggested as an alternative to the push pull antenna due to its better isolation between the input and output ends as well as superior matching properties. We consider an important application for which the balanced amplifying antenna is naturally more suitable than the push-pull amplifying antenna. There are many practical situations, which require circularly polarized antenna. The outputs of the balanced amplifier are 90° apart in phase and hence it can be a suitable candidate for active circularly polarized antenna. Most high power amplifying antennas contain two independent devices without any internal transversal connection between them. Invariably these devices are connected in the push-pull [1] configuration. Usually the push-pull configuration is used for relatively narrow band commercial applications from UHF to S-band. Due to its popularity with the circuit designers, it has been implemented in active integrated antenna.

However, there are a variety of alternative configurations to be combined external components such as 180-degree splitters/combiner (baluns [2]), 3 dB quadrature couplers (like branch line or Lange couplers), in-phase couplers (like Wilkinson couplers), etc. In microwave circuits the balanced [3] configuration also finds wide application. This paper proposes a sequential fed balanced configuration as an alternative to Push-Pull configuration as well as for circular polarization.

## 2. CIRCULAR POLARIZED ANTENNA

Inherently antenna radiates elliptically polarized waves; linear polarization being a particular case of it. The elliptical polarization is characterized by three quantities: axial ratio, tilt angle and the sense of rotation [1, 2]. For linear polarization, the axial ratio is zero or infinite while the tilt angle gives its orientation. Circular polarization (CP) is obtained for unit axial ratio, where the tilt angle loses its meaning. Thus the quality of circularly polarized wave is determined by the axial ratio [3-5].

Antennas can give circular polarization if two orthogonal components with equal amplitude but in phase quadrature are radiated. A patch antenna capable of supporting two orthogonal modes in phase quadrature simultaneously as well as an array of linearly polarized patches with proper orientation and phasing are capable of producing circular polarization. This paper considers both these structures simulated using AWR Microwave Office™ and IE3D®™ [6]. The next section describes a single element circularly polarized patch antenna. We consider a square antenna with dual inset feeds on orthogonal sides of the patch. Unlike in conventional passive square antenna with dual orthogonal feeds, the feed structure is not required to introduce the 90° phase shift here. The reason for this lies in the amplifying system, which produces outputs, which are 90° out of phase. The schematic of the dual fed patch antenna is shown in Fig.1. The physical parameters of the antenna for the design frequency of 2.4 GHz are given in Table.1. The S-parameters of the feeding port 1 and the polar radiation pattern of the antenna are shown.

## 3. BALANCED AMPLIFYING ANTENNA

The balanced amplifier employs two quadrature hybrids. Reflections of the input signals due to poor matching are channeled back to a matched load where they get absorbed. Same phenomenon occurs at the output port also. Therefore, theoretically, both at input and output ports one will see matched loads. A schematic of this configuration is depicted in Fig 1. The real advantages of an ideal balanced configuration include good isolation with improved stability; good input and output external matching; cancellation in the load of products and harmonics like  $2f_1+f_2$ ,  $2f_2+f_1$ ,  $3f_1$ ,  $3f_2$ ... and attenuation by 3dB of products like  $f_1\pm f_2$ ,  $2f_1$ ,  $2f_2$ ... Further the balanced amplifier has clear edge over the push-pull counterpart in terms of the output impedance matching. It is also more stable due to good isolation between its input and output sides. These characteristics have

inspired us to consider a balanced configuration for the active antenna instead of the conventional push pull configuration. This amplifier is simulated using AWR Microwave Office™ [6]. The disadvantages include matched load to dissipate power in the decoupled port; no virtual ground and hence less compact structural realization.

Using the optimization feature of the EDA software AWR Microwave Office™, the amplifier was designed for optimized gain and noise figure. Normally, active integrated antenna amplifier design still follows the procedure of microwave transistor amplifiers. The only difference being that the radiating patch acts the load in transmitting case and as source impedance for the receiving antenna. If  $Z_s$  is the complex source impedance and  $Z_l$  is the input impedance of the patch antenna, then the transducer power gain  $G_T$  is defined as the ratio of power delivered to the load  $Z_l$  to the power available from the source [7,8].

The expression for  $G_T$  in terms of  $\Gamma_s$  and  $\Gamma_l$  is

$$G_T = \frac{1-|\Gamma_s|^2}{|1-\Gamma_{in}\Gamma_s|^2} |S_{21}|^2 \frac{1-|\Gamma_l|^2}{|1-S_{22}\Gamma_l|^2} \quad (1)$$

$$G_T = \frac{1-|\Gamma_s|^2}{|1-S_{11}\Gamma_s|^2} |S_{21}|^2 \frac{1-|\Gamma_l|^2}{|1-\Gamma_o\Gamma_l|^2} \quad (2)$$

In the above equation,

$$\Gamma_{in} = S_{11} + \frac{S_{12}S_{21}\Gamma_l}{1-S_{22}\Gamma_l} \quad (3)$$

$$\Gamma_o = S_{22} + \frac{S_{12}S_{21}\Gamma_s}{1-S_{11}\Gamma_s} \quad (4)$$

For unconditional stability of the transistor, the necessary and sufficient condition is expressed by the following two inequalities, in terms of  $\Delta$  ( $= S_{11}S_{22}-S_{21}S_{12}$ ).

$$K = \frac{1-|S_{11}|^2-|S_{22}|^2+\Delta^2}{2|S_{12}S_{21}|} \quad (5)$$

$$|\Delta|^2 < 1 \quad (6)$$

The following gives sample design of a balanced amplifier. From Fig.2(a) for the VSWR, the matching at the input and output ports over the desired frequency band is observed to be excellent. The performance of the amplifier is observed in Fig.2(b) for the noise figure and the gain. Both these observations indicate a satisfactory design. It is also seen that the antenna is properly matched ( $S_{22}$  around -22dB) at the desired frequency of 2.4 GHz. The noise factor is slightly more than 2.21dB, where as the gain is more than 10dB. The radiation pattern at 2.4 GHz is undistorted, which suggests that the antenna is radiating in its dominant mode and the radiation is not contaminated by harmonic interferences.

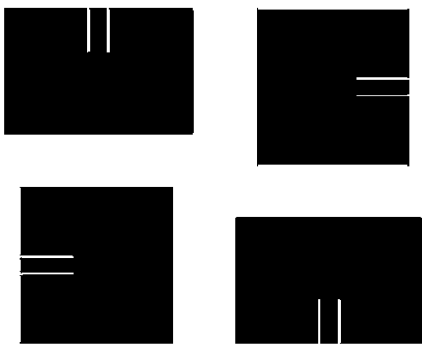

Fig.1. Sequentially Rotated Array for CP

Table.1. Physical Dimension of Array

Patch width	Patch length	Inset feed depth	Gap between adjacent edges
44.52874mm	35.8013mm	11.6689mm	15.299mm

#### 4. SEQUENTIAL FED BALANCED AMPLIFYING ANTENNA

In this paper a planner arrangement of the patch antenna elements is considered to form an array. Each element in the array is linearly polarized. The phase of the feeding in the array increases progressively from  $0^0$  to  $270^0$  [9-14]. In other words the elements are uniformly distributed in each of the phase quadrant by such a feeding arrangement. Thus the phase quadrature part is taken care off. To achieve this we considered only four elements, arranged at the four corners of a square domain. The manner of arrangement is such that each antenna sees its adjacent ones to be radiating from an edge orthogonal to its edge of radiation. To achieve this, each antenna is rotated by  $90^0$  sequentially [15-18]. The schematic of the arrangement is shown in Fig.1. The physical parameters for this array are shown in the table 1. The substrate parameters are the same as those of the square patch discussed in the above section.

#### 5. RESULTS AND DISCUSSION

This array is first tested for its performance. The design frequency for this array was 2.4GHz. However, the arrangement was optimized to maximize the antenna efficiency. The variation of efficiency with frequency is depicted in Fig.2. It is observed that the frequency for highest gain is 2.36GHz. The elevation gain patterns for both RHCP & LHCP are shown in Fig.3. Fig.4. shows the variation of axial ratio and Fig 5 shows the variation of gain with frequency. It is observed that the gain remains almost constant at 8dBi over the frequency band; whereas good axial ratio ( $AR = 2.4$ ) is obtained for 2.37GHz. As per the above discussion, the elements of the array are to be sequentially fed with progressive phase shifts. On the other hand the balance amplifier has two output terminals. It means it is necessary to generate two more terminals, in such a manner that  $0^0 - 90^0 - 180^0 - 270^0$  phase shift across the terminals can be realized. Additional amplification is necessary to compensate for non-radiating losses like conductor loss, dielectric loss, etc.

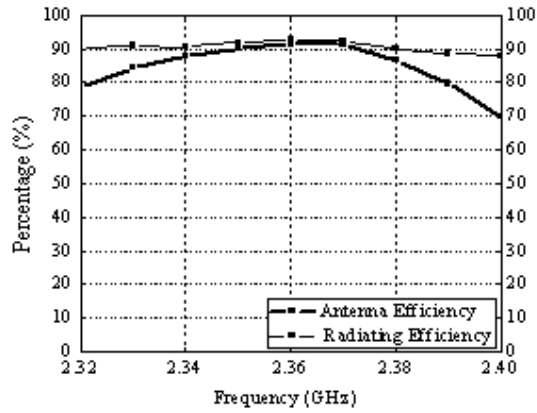

Fig.2. Variation of efficiency with frequency for sequentially rotated array

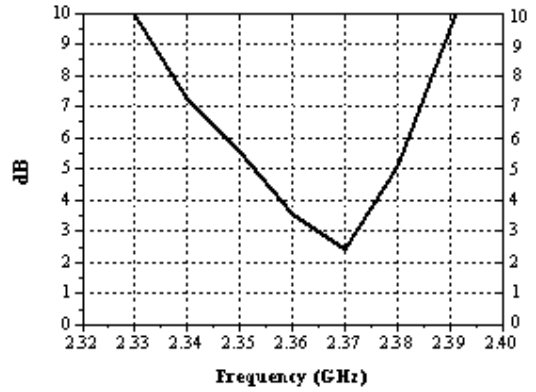

Fig.4 Axial Ratio variation with frequency

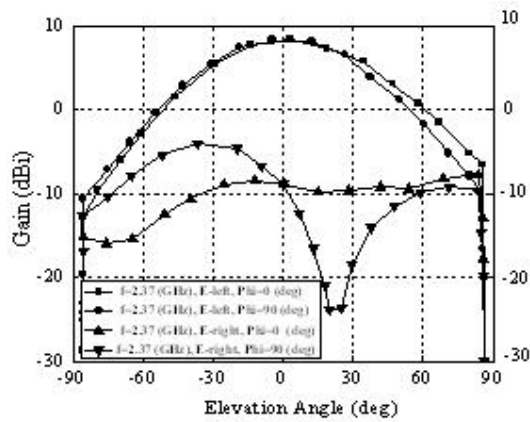

Fig.3. RHCP & LHCP pattern for the sequentially fed array

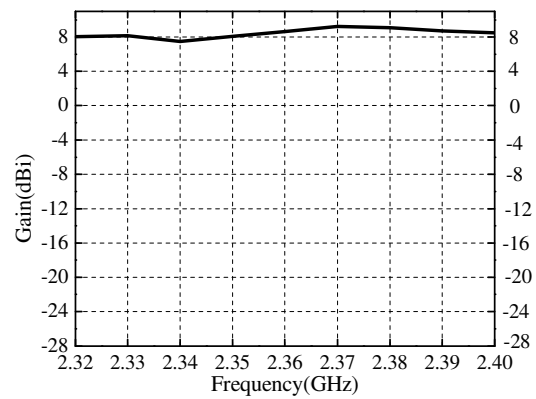

Fig.5. Gain ~ Frequency Characterization

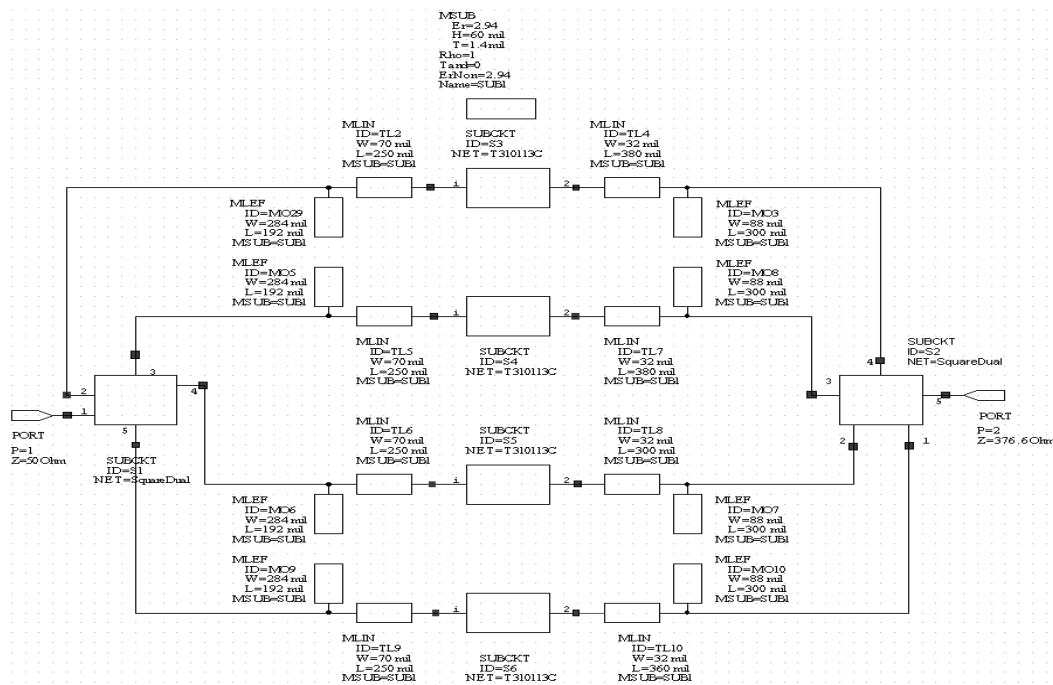

Fig.6. Amplifying Sequential fed CP antenna Schematic

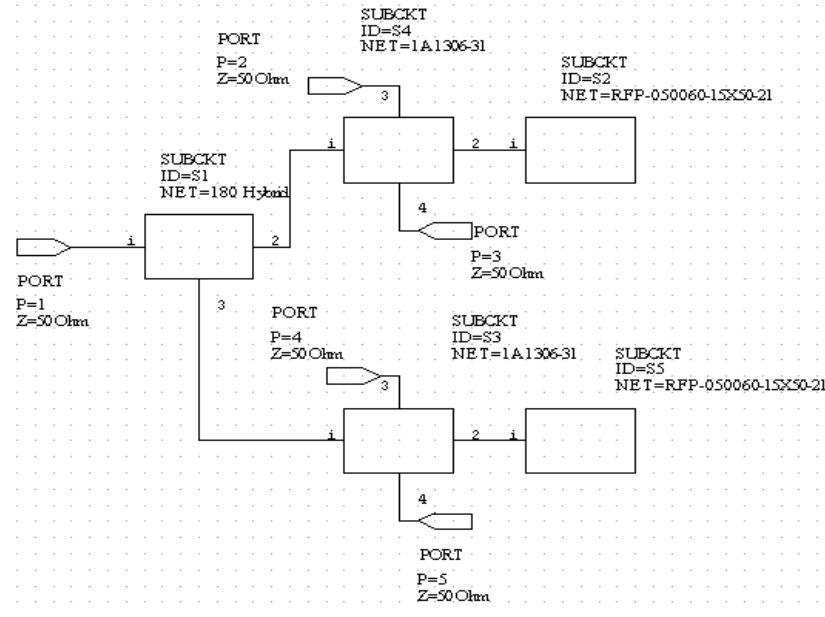

Fig.7. Sub-circuit of Phase Splitter

This can be done by combination of hybrids. First a  $0^\circ - 180^\circ$  hybrid is taken and each of its output connected to  $0^\circ - 90^\circ$  hybrids. Then from the  $0^\circ$  end  $0^\circ - 90^\circ$  phases will be obtained. Similarly from the  $180^\circ$  end  $180^\circ - 270^\circ$  phases will be obtained. A pair of balanced amplifier is used at each of the ends, i.e.  $0^\circ - 90^\circ$  phase-ends and  $180^\circ - 270^\circ$  phase-ends. The outputs from the balanced amplifiers are then accordingly connected to the antennas. The schematic of microwave simulation is shown in Fig.6.

The details of phase splitter connected to the port #1 are shown in Fig.7. It contains a  $180^\circ$  and two  $90^\circ$  hybrids as discussed earlier. The equivalent sub-circuit for the antenna array models the four antennas as lossless coupled transmission lines gap coupled to another transmission line of characteristics impedance 376.6 ohms. The transmission lines representing the antenna are designed in such a manner that their input impedances are equal to the input impedance of the corresponding antennas.

The gain and noise figure of the balanced amplifying sequentially fed circular polarized antenna is shown in Fig.8. It can be noticed that compared to the dual feed case; the noise figure is considerably reduced here to be less than -19 dB. This is within acceptable design limit. The gain is also between 6.3 to 6.5 dB. The reason for this can be the use of a pair of balanced amplifier.

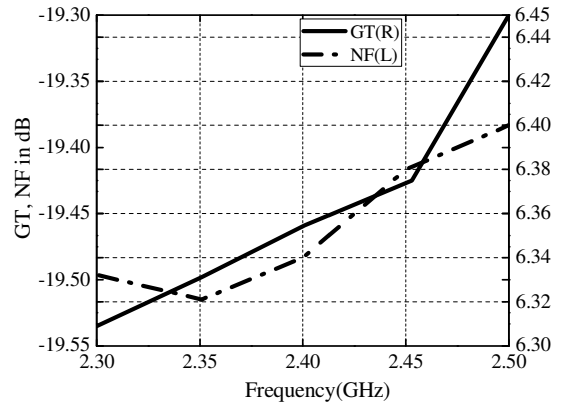

Fig.8. NF & GT of Sequential Fed Balanced Amplifying CP Antenna

## 6. CONCLUSION

This paper exploits the use of balanced amplifier for design of active circularly polarized antenna. Two different configurations are considered. It is observed that sequentially fed array gives better performance than the dual fed antenna, as far as the noise figure and gain are concerned. However as stand-alone circularly polarized antenna their performances do not vary very much. The design complexities in both the cases are involved. Neither there is any closed form formulae nor is a defined procedure to follow for keeping the mutual coupling between the ports to minimum. This is to be achieved by trial and error and hence is the most difficult part in the whole design process.

## ACKNOWLEDGEMENT

The authors would like to thank A. W. R. Inc., USA for providing the Demo copy of Microwave Office 2000.

## REFERENCES

- [1] K. Inoue, K. Ebihara, H. Haematsu, T. Igarashi, H. Takahashi and J. Fukaya, 2000, "A 240 W Push-Pull GaAs Power FET for W-CDMA Base Stations", IEEE MTT-S Digest, pp.1719-1722.
- [2] R. Basset, 1980, "Three Balun Designs for Push-Pull Amplifier", Microwave, pp. 47-53.
- [3] C. A. Balanis, 1997, "Antenna Theory, Analysis and Design," John Wiley & Sons, New York.
- [4] W. L. Stutzman, G. A. Thiel, 1981, "Antenna Theory and Design," John Wiley & Sons, New York.
- [5] P. S. Hall, J. S. Dahel, 1997, "Dual and Circularly polarized Microstrip antennas," in Advances in Microstrip and Printed Antennas, K. F. Lee, W. Chen (Eds.), John Wiley & Sons, New York.
- [6] "AWR Design Environment", Applied Wave Research Inc. USA
- [7] G. Gonzales, 1997, "Microwave Transistor Amplifiers: Analysis and Design", 2nd ed., Prentice Hall, Upper Saddle River, NJ.
- [8] R. L. Bauer, J. J. Schuss, 1987, "Axial Ratio of Balanced and Unbalanced Fed Circularly Polarized Patch Radiator Arrays," IEEE AP-S Int. Symp. Ant. Propag., pp.286 – 289.
- [9] P. S. Hall, J. S. Dahel, J. R. James, 1989, "Design Principles of Sequentially Fed, Wide Bandwidth, Circularly Polarized Antennas," IEE Proc., Pt. H, Vol. 136, pp. 381 – 389.
- [10] P. S. Hall, 1989, "Applications of Sequentially Feeding to Wide Bandwidth, Circularly Polarized Antennas," IEE Proc., Pt. H, Vol. 136, pp. 390 –398.
- [11] S. Song and R. Basset, 2000, "S-Band Amplifier Modelled for Wireless Data", Microwave & RF, pp. 53-160.
- [12] S. Cripps, "RF Power Amplifiers for Wireless Communications", Artech House Boston London, pp.294-302.
- [13] L. Max, 1977, "Balanced Transistors: A New Option for RF Design", Microwaves, pp. 40-46.
- [14] "Low Current, High Performance NPN Silicon Bipolar Transistor", Agilent (HP) Technical Data 5965 – 8919E.
- [15] S K Behera, R K Mishra, D R Poddar, 2007, "Balanced amplifying antenna for circular polarization", IEEE International Conference on Applied Electromagnetics Conference, pp.1 – 4.
- [16] S K Behera, R K Mishra, D R Poddar, 2007, "Balanced amplifying microstrip patch antenna at 2.4 GHz", IEEE International Conference on Applied Electromagnetics Conference.
- [17] Low Noise Amplifier Design Project - <http://www.educatorscorner.com/experiments/pdfs/exp98/exp98tech.pdf>
- [18] Testing CDMA Base Station Amplifiers , Application Note, <http://literature.agilent.com/litweb/pdf/5967-5486E.pdf>