

Design of Slow Sand Filter Technology for Rural Water Treatment in Girei, Adamawa State, North Eastern Nigeria

B. A. Ankidawa^{1*} and A. A. Tope¹

¹*Department of Agricultural and Environmental Engineering, Modibbo Adama University of Technology, P.M.B. 2076, Yola, Adamawa State, Nigeria.*

Authors' contributions

This work was carried out in collaboration between both authors. Author BAA designed the study, performed the statistical analysis, wrote the protocol, wrote the first draft of the manuscript, managed the analyses of the study and managed part of literature searches. Author AAT carried out the design work of the study and managed some part of the literature searches. Both authors read and approved the final manuscript.

Article Information

DOI: 10.9734/AJEE/2017/34395

Editor(s):

(1) George Tsiamis, Department of Environmental and Natural Resources Management, University of Patras, Agrinio, Greece.

Reviewers:

(1) Tatjana Momic, University of Belgrade, Serbia.

(2) Klaus Doelle, State University of New York (SUNY), USA.

(3) Miraji Hossein, University of Dodoma, Tanzania.

Complete Peer review History: <http://www.sciencedomain.org/review-history/19902>

Original Research Article

Received 26th May 2017
Accepted 1st July 2017
Published 6th July 2017

ABSTRACT

Treatment of water has a great influence on the use of water for domestic use both in rural and urban areas. Slow sand filtration involves the use of beds of sand for the filtration of water. The reason for designing slow sand filter for rural water treatment is to make treatment of water easy and qualitative. This research involves the use of three tanks, filter beds, filter media and filtrate tanks. Raw water is filtered by the layers of different sand particles, and conveyed by pipe after filtration to the filter media that has diatomite as the sieving agent which filters the water before been conveyed into the filtrate tank. From test carried out, the result shows that slow sand filter with filter technology is moderately efficient for water treatment. The design of slow sand filter technology applied appropriate technology; hence the ease of filtering raw water as well as improvement in taste and odor of water being treated was achieved. However, chemical and biological contaminants were not considered in this research.

*Corresponding author: E-mail: ankidawa03@yahoo.com;

Keywords: Sand; filter technology; water treatment; tanks; diatomite; rural area; technology.

1. INTRODUCTION

1.1 Background Information

Water is necessary for many purposes ranging from domestic uses, industrial water supply and irrigation [1]. Slow sand filter was proven to be sustainable and reliable drinking water treatment alternative for a small community like Sabon Gari Girei community, which can be beneficial for addressing the small systems challenges [2]. Slow sand filtration has been an effective water treatment process for preventing the spread of gastrointestinal disease for over 150 years, having been first used in Great Britain and later in other European countries. Slow sand filters were built to serve communities in North America both before and after 1900, but the advent of effective coagulation, sedimentation, and rapid rate filtration resulted in a declining interest in slow sand filtration in North America in the early part of the twentieth century [3]. Slow sand filtration was used in China in the 1930s and 1940s, but later, rapid gravity filtration found favor due to the land requirements for slow sand filters in the urban areas since the 1980s [4]. Slow sand filtration has been applied in rural areas in China for small-scale water treatment facilities [5].

The efficiency of slow sand filtration depends on the particle size distribution of the sand, the ratio of the surface area of the filter depth and the flow rate of water through the filter [6]. The finest grade sand fractions and granulated Rockwool have been shown to be most efficient in controlling disease such as *Phytophthora*, *Pythium* and *Furacium oxosporum*, the most wide spread nursery disease [7].

Slow sand filters have traditionally been designed with a bed of sand initially about 1m in depth with about 1 m of super-natural water. The effective size of the filter sand ranges from about 0.15 – 0.35 mm [8] recommended that the uniformity co-efficient should be less than 5 and preferably less than 3. Filtration rates are typically in the range of 0.1 – 0.3 m/h [9,10] or 1 – 2% of this rate control. In a slow sand filter, the filter bed is constructed of a medium with high surface area which can be colonized by suppressive microorganisms. This fine media also presents a physical barrier to the passage of spores of plant pathogens. Bacteria, such as representative of the genus *Pseudomonas* and

Trichoderma have been demonstrated as biological control agents effectively controlling plant pathogens in hydroponics systems. In a slow sand filtration, plant pathogen recirculating in the irrigation water are captured in the filter media, and at slow rates of water filtration (100 – 200 1/hr/m² surface area of filter), are acted upon by the antagonistic micro-organism that colonized this filter bed.

Treatment of water for rural community has been a very major problem culminating against the utilization of water for domestic and drinking purpose for entire rural community. The existing method used in treatment of water for rural community seems very expensive and sometimes the chemical obtained directly from stream is very harmful and deadly to the community. Secondly the water treatment process use in supply of water to urban area seems very cumbersome and cannot be used in small community. Then, the need arises to construct a slow sand filtration unit that is very efficient and cost effective for rural area. This research is aimed at constructing a slow sand filter with a filter aid filtration unit for rural water treatment using locally available materials.

2. MATERIALS AND METHODS

2.1 Design Theories

The design of slow sand filter unit with filter aid involves the study of decision making processes which was used in the formulation of plans for the physical realization of the unit. Certain criteria are taken into consideration.

- i) Selection of material: for example, factor governing the choice of material, which include strength, durability, flexibility, weight, corrosion resistance.
- ii) Safety of operation cost of production and finally assembly.

A Tank is required to carry the sizes of sand alongside the raw water that is to filter. It is necessary to consider the material that was used in the design of the tank. This material should be a ductile material of high resistance to corrosion thus mild steel is selected based on the fact that those properties listed above were fulfilled by it. In determination of the height of the tank it was considered that the length is known by assuming a value [10]. The area of the tank was computed from equation 1 below.

$$A = L \times B \quad (1)$$

where A is area of the tank (m²), L is length of the tank (meter), B is breath of the tank (meter).

$$Q = A \times V \quad (2)$$

where Q is the quantity of fluid carried per minute, A is area of the tank (m²), V is velocity of the fluid flowing per minute (m/s) [11].

$$\text{Since } Q = \frac{V \cdot}{t} \quad [11] \quad (3)$$

where V is volume of the tank (m³), t is time taken (seconds)

The inside diameter of the pipe depends upon the quantity of the fluid to be delivered and it was computed from equation below.

$$Q = \frac{\pi \times D^2 \times V}{4} \quad (4)$$

After deciding upon the inside diameter of the pipe, the thickness of the wall (t) in order to withstand the internal fluid pressure (p) was obtained by using thin cylinder formula.

$$t = \frac{PD}{2\delta} \quad (5)$$

where t is thickness, D is diameter of pipe, δ is stress in pipe. Thus;

$$\delta = \frac{\delta_t}{P} \quad (6)$$

For cast Iron material the allowable tensile stress (δ_t) for commercial purpose is 14N/mm² [12].

It is expected that the smaller tank be half the volume of the bigger tank in the sense that virtually half of the water is being absorb by the layers of sand and some of the impurities that as added to the volume as being remove by this slow sand filter and also by the filter aid. Thus,

$$V_s = \frac{V_L}{2} \quad (7)$$

where Vs is volume of large tank (m³), VL is volume of the smaller tank (m³).

The kind of valve to be selected to control the inflow and discharge of water is based on the kind of fluid into be carried it expected that for water with little impurities or raw water a gate valve and globe valve was selected. For the

purpose of the design gate valve is selected because of availability and ease of opening and closing. The essence is to hold the work together the stress due to the weight on weld is assumed to be equally distributed.

A fillet form of welding is choosing for the design of frame and weld. Thus the effective weld force or strength of fillet P is given as.

$$P = L \times t \times \delta \quad (8)$$

where δ is the permissible stress for axial compression or tension and is usually given as 140 Mpa [13], L is the total length of weld or welded length, t is the effective throat thickness and it is usually.

$$t = Kx \quad (9)$$

where x = is the size of the weld which is 6 mm, K = is a constant (for welding angle between 60 to 90 C and K = 0.7) [13,14]. Production cost of this equipment is shown in Table 1.

There are two main steps for selection of material for the design and construction of this machine which includes; 1. Screening and ranking, 2. Supporting information. Unbiased selection required that all materials are considered to be candidates until proven otherwise. The first of step is screening which involve elimination of candidate which cannot do this job at all because one or more of its properties or attribute lies outside the limits imposed by this designer thus this requirement was referred to as property limit. Further selection was done by applying material indices to find the candidate that can do the job better by ranking the candidate.

The outcome of result of screening and ranking steps was a shortlist of candidate which satisfies the requirement of the design; to proceed a detail profiled of the supporting information on each candidate was seek. The final choice between competing candidates depend on the local conditions, that is, the weather and climate conditions of where they will be used.

From the specifications of material selection given above, the materials used were based on their costs of the material. In the design and fabrication of most Engineering equipment model, it is advisable and more economical to use Aluminum and Mild Steel because of their resistance to corrosion and relatively cheap cost.

Table 1. Average material costing

S/NO	Material description	Quantity	Unit cost USD (\$)	Total cost USD (\$)
1.	Sheet metal (unprotected) gauge	5/9	5	25
2	Sheet metal (unprotected) gauge	1/9	3	3
3	Sheet metal (unprotected) 3/9	3/9	3	9
4	¾ round pipe (galvanized)	36" Long (3ft)	3	9
5	Gate valve made of brass	1	4	4
6	Metal tap head made of copper	1	3	3
7	Socket made of galvanized	5	3	15
8	Auto base paint	1 medium size tin	4	4
9	Elbow joint made of galvanized pipe	1	3	3
10	Electrode (gauge) mild steel	30 pieces	0.5	15
11	1" square pipe black (mild steel)	3	5.5	16.5
12	Diesel for gem	4 liters	6	24
Total USD (\$)				130.5

Steel was used for the design of the equipment. For the fact that components are produced by varying methods depending on the availability of material relative weight, technological know-how and other unforeseen circumstances, all items have different cost attached to them. The cost of obtaining the equipment is only \$130.5 which is affordable for the household to buy Table 1.

3. RESULTS AND DISCUSSION

Construction involves the fabrication of the various part that make up the equipment and putting them together to operate as a composite member that is to say the fabricated parts were assembled to form a single product (slow sand filtering unit) [15]. The construction started with marking out, cutting bending of the bank, welding, assembling, finishing and testing. Some of these component uses were standard e.g. vale and tap head were selected and purchased from the local market. The square pipe was marked out with a scribe according to the dimensional requirement specified on working drawing. The frame was cut and welded into the shape of the main frame. The metal steel sheet [16] was measured according to the dimensional requirement on the working drawing and thereafter it is marked out with a scribe and folded with a perfect tank and welded together to avoid leakage.

The cylindrical pipe of diameter 23 mm was marked out to the required dimension thereafter

it was then cut with hawk saw to the required length. The mainframe was formed by welding together with the part making up the frame. The big tank was welded tighter and a small hole of equal diameter to the pipe is to derived at the bottom of the tank thus welded on it is a small treaded pipe joint 'A' which the treaded pipe is to be joined, and connected to it is a ball value that is thus link to the filter aid media. A pipe form filtration media is link or connected to the smaller tank (filtrate tank). The pipe which is also treaded to the elbow joint through fastening to the smaller tank. The entire unit is thus molted on the main frame wheel act a support to the filtering unit.

The evaluation of slow sand filter (Fig. 1) was carried out by using the standard parameter. Table 2 shows the test result in comparison with standard parameter from [17,18,19] their studies are similar with the present research work, there results were slightly different with the result obtained in the present study. The difference could be as a result of different environment the research carried out or it could be as a result of other factors such as climatic condition of the areas. The result shown below gives a clear indication that slow sand filter with filter aid is partially efficient for treating raw material for rural area. Since there is little or no difference between the standard values obtained from WHO (2010) and the result obtained in the course of the test. Thus slow sand filtering is moderate of treating water for rural water treatment.

Table 2. Test result

S/N	Test	Result	WHO (2010) standards
1	pH test	6.5	7-9
2.	Membrane filtration test	Partially colourless	Colorless mesh
3.	Total dissolved solid test.	≥ 3	≥ 5
4.	Taste and odour test	Tasteless and odourless	Tasteless, odourless
5	Sludge test	50%	30% - 40%
6	Iron test	0.3 ppm	0.1ppm
7	Macro biological	Absent	Absent
8	Algar	0	0
9	Protozoan	1	0
10	Micro biological factors	0	0
11	Total Califorms	1	0

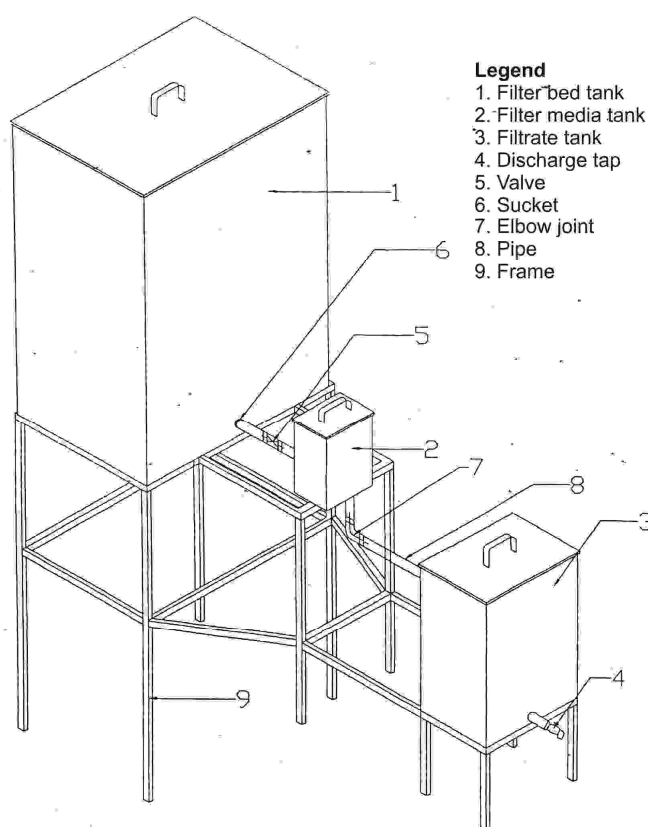
**Fig. 1. Assembly drawing of the slow sand filter**

3.1 Principle of Operation

Raw water was introduced through the inlet (the upper part) of the big tank (filter bed tank) (Fig. 1). The big tank comprises of various soil size ranging from the gravel that form the bed to the smallest size of the sandy soil as the water gradually flow through the layer of soil particle that are unwanted are being tapped by microbial action. Thus the raw water is

gradually been filter by the layer or bed of soil. The discharge at the lower part of the tank is open to allow the filter water to further pass through a filter aid container where it further been filter by the "diatomite" which serve the purpose of sieve to further purify the water thereafter the water is collected through gravitational mean into the smaller tank where the water can be collected for domestic use.

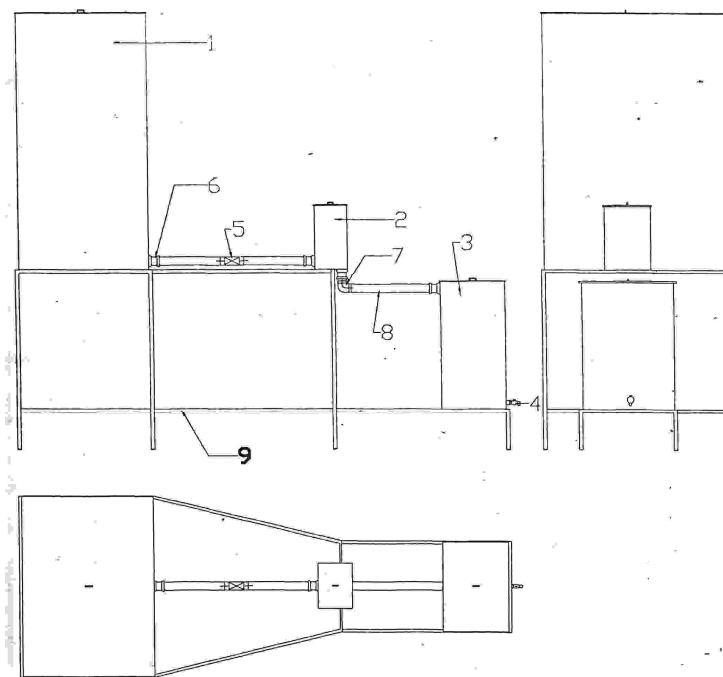

Fig. 2. Orthographic view of the slow sand filter

4. CONCLUSION

The design of the slow sand filter technology has a simple operation and should have high filtration efficiency, however, the result obtained actually shows that there is a little deviation in the performance of the slow sand filtering unit that is designed and constructed. Thus there is still need for improvement on the performance of the slow sand filter especially in carrying out research on suitable sand that can be used to achieve proper filtration. With the result obtained, the ease of filtering raw water as well as improvement in taste and odor of water being treated was achieved. However, chemical and biological contaminants were not considered in this research. Thus, the slow sand filter if made available to the rural area will help solve the problem encountered with treatment of water.

COMPETING INTERESTS

Authors have declared that no competing interests exist.

REFERENCES

1. Saladi JA, Salehe FS. Assessment of water supply and its implications on

household income in Kabuku Ndani Ward, Handeni District, Tanzania. *Asian Journal of Environment & Ecology*. 2017; 2(1):1-26.

2. Cleary SA. Sustainable drinking water treatment for small communities using multistage slow sand filtration. Published M.Sc. Thesis, Waterloo, Ontario, Canada. 2005;1-288.

3. Baker DL, Duke F. Intermittent slow sand filters for household use - A field study in Haiti. IWA Publishing, London, UK. 2006; 1-4.

4. Nkwonta O, Ochieng G. Roughing filter for water pre-treatment technology in developing countries: A review. *International Journal of Physical Sciences*. 2009;4(9):455-463.

5. Saravanan SP, Gobinath R. Drinking Water safety through bio sand filter - A case study of Kovilambakkam Village, Chennai. *International Journal of Applied Engineering Research*. 2015;10(53):254-262.

6. Clark PA, Pinedo CA, Fadus M, Capuzzi S. Slow-sand water filter: Design, implementation, accessibility and sustainability in developing countries. *Med Sci Monit*. 2012;18(7):105-117.

7. Barth G. Slow flow sand Filtration (SSF) for water treatment in nurseries. The Nursery Paper. 2001;1-7.
8. Zaman S, Yeasmin S, Inatsu Y, Ananchaipattana C, Bari ML. Low-cost sustainable technologies for the production of clean drinking water-a review. Journal of Environmental Protection. 2014;5:42-53.
9. Sims RC, Slezak LA. Slow sand filtration: Present practice in the United State. In slow sand filtration. American Society of Civil Engineers, New York, Edited by G. Logsdon; 1991.
10. Seger A, Rothman M. Slow sand filtration with and without ozonation in Nordic climate. In Advances in slow sand and alternative Biological filtration. Graham, N., Collins, R. John Willey & Sons Ltd., England; 1996.
11. Hunter P. Household water treatment in developing countries: Comparing different intervention types using meta-regression. Environ. Sci. Technol. 2009; 43:8991-8997.
12. Burleson GE. Water treatment technologies for the developing world. Published B. SC in Mechanical Engineering Thesis, Oregon University. 2016;63.
13. Rabbani KS. Low cost domestic scale technologies for safe drinking water. Appropriate Healthcare Technologies for Developing Countries; 2012.
14. Sission AJ, Wampler PJ, Rediske RR, Molla AR. An assessment of long-term bio sand filters use and sustainability in the Artibonite Valley near Deschapelles, Haiti. Journal of Water, Sanitation and Hygiene. 2013;3(1):51-60.
15. Taghizadeh MM, Torabian A, Borghei M, Hassani AH. Feasibility study of water purification using vertical porous concrete filter. Int. J. Environ. Sci. Tech. 2007;4(4): 505-512.
16. Collins MR, Cole JO, Westersund CM, Paris DB. Assessing roughing filtration design variables. Water supply. 1994; 12:1-2.
17. World Health Organization. Guidelines for drinking water quality, World Health Organization, Geneva; 2010.
18. APHA. Standard methods for examination of water and waste water 15th Ed. American pub. Health Asso. Washington D.C; 1995.
19. Jones SA, Anya A, Stacey N, Weir L. A life-cycle approach to improve the sustainability of rural water systems in resource-limited countries. Challenges. 2012;3:233-260.

© 2017 Ankidawa and Tope; This is an Open Access article distributed under the terms of the Creative Commons Attribution License (<http://creativecommons.org/licenses/by/4.0>), which permits unrestricted use, distribution, and reproduction in any medium, provided the original work is properly cited.

Peer-review history:
The peer review history for this paper can be accessed here:
<http://sciencedomain.org/review-history/19902>