

Design of State-Space-Based Control Algorithms for Wind Turbine Speed Regulation

Preprint

A. Wright

National Renewable Energy Laboratory

M. Balas

University of Colorado at Boulder

To be presented at the 21st American Society of Mechanical Engineers (ASME) Wind Energy Symposium

Reno, Nevada

January 14–17, 2002



NREL

National Renewable Energy Laboratory

1617 Cole Boulevard
Golden, Colorado 80401-3393

NREL is a U.S. Department of Energy Laboratory
Operated by Midwest Research Institute • Battelle • Bechtel

Contract No. DE-AC36-99-GO10337

NOTICE

The submitted manuscript has been offered by an employee of the Midwest Research Institute (MRI), a contractor of the US Government under Contract No. DE-AC36-99GO10337. Accordingly, the US Government and MRI retain a nonexclusive royalty-free license to publish or reproduce the published form of this contribution, or allow others to do so, for US Government purposes.

This report was prepared as an account of work sponsored by an agency of the United States government. Neither the United States government nor any agency thereof, nor any of their employees, makes any warranty, express or implied, or assumes any legal liability or responsibility for the accuracy, completeness, or usefulness of any information, apparatus, product, or process disclosed, or represents that its use would not infringe privately owned rights. Reference herein to any specific commercial product, process, or service by trade name, trademark, manufacturer, or otherwise does not necessarily constitute or imply its endorsement, recommendation, or favoring by the United States government or any agency thereof. The views and opinions of authors expressed herein do not necessarily state or reflect those of the United States government or any agency thereof.

Available electronically at <http://www.osti.gov/bridge>

Available for a processing fee to U.S. Department of Energy
and its contractors, in paper, from:

U.S. Department of Energy
Office of Scientific and Technical Information
P.O. Box 62
Oak Ridge, TN 37831-0062
phone: 865.576.8401
fax: 865.576.5728
email: reports@adonis.osti.gov

Available for sale to the public, in paper, from:

U.S. Department of Commerce
National Technical Information Service
5285 Port Royal Road
Springfield, VA 22161
phone: 800.553.6847
fax: 703.605.6900
email: orders@ntis.fedworld.gov
online ordering: <http://www.ntis.gov/ordering.htm>



ABSTRACT

Control can improve the performance of wind turbines by enhancing energy capture and reducing dynamic loads. At the National Renewable Energy Laboratory*, we are beginning to design control algorithms for regulation of turbine speed and power using state-space control designs. In this paper, we describe the design of such a control algorithm for regulation of rotor speed in full-load operation (region 3) for a two-bladed wind turbine. We base our control design on simple linear models of a turbine, which contain rotor and generator rotation, drivetrain torsion, and rotor flap degrees of freedom (first mode only). We account for wind-speed fluctuations using disturbance-accommodating control. We show the capability of these control schemes to stabilize the modeled turbine modes via pole placement while using state estimation to reduce the number of turbine measurements that are needed for these control algorithms. We incorporate these controllers into the FAST_AD code and show simulation results for various conditions. Finally, we report conclusions to this work and outline future studies.

INTRODUCTION

One of the main goals of wind turbine control is to increase power production and reduce loads using a minimum number of control inputs and required turbine measurements. Often, controls can be designed to simultaneously satisfy more than one objective, i.e., regulate power and reduce loads. In the 1970s and 1980s, classical control design methods (such as proportional integral [PI]) were used to design controllers to regulate power while also adding damping to the first drivetrain torsional mode of the turbine¹. In Barton et al.², a power system stabilizer was included to add damping to the drivetrain mode.

Work has also been done in Europe using state-space methods for wind turbine control design. Mattson³ designed a controller for regulation of power below rated wind speed for a fixed-speed machine using blade pitch. In this work, rotor rotation, drivetrain torsion, and tower fore-aft degrees of freedom (DOF) were modeled for use in control system design. Liebst⁴ describes the use of individual blade periodic pitch control to reduce the loads on the Mod 0-A turbine because of tower shadow, wind shear, and gravity. In this paper, only blade DOF were modeled in the

dynamics, using rigid blade/hinge models to represent the blade flap, lag, and pitch DOF.

In the United States, work has been reported by Stol et al.⁵ in the use of state-space methods to design disturbance accommodating controls (DACs). They developed a linear model of a turbine using a rigid blade/tower/hinge approach to model blade and tower flexibility. They developed DAC from a linear model containing only rotor rotation as the degree of freedom. They then showed that this DAC adequately controlled a turbine as modeled in their nonlinear simulator-SymDyn with just the rotor rotation degree of freedom. This system became unstable when more DOF were turned on in SymDyn than included in the linear model for controller design.

These investigations show that consideration must be given to unmodeled structural DOF when designing a controller. Less aggressive control gains could probably be chosen for the lowest-order controllers, resulting in stable behavior of the complete wind turbine. However, there will always be components in a wind turbine that are difficult to model or have uncertain properties. It is important to begin to assess the importance of these unmodeled effects in the design of controllers for wind turbines. A balance must be attained between the controller complexity (the controller will be more complex if many turbine DOF are accounted for in its design) and ease of actual implementation. An appropriate question is, Which turbine DOF are most critical for inclusion in the models used for controller design?

In this paper, we show the design of a control system for regulation of turbine rotational speed at full-load (above rated power for a variable-speed turbine, i.e., region 3) using DAC, while also adding damping to flexible modes of the turbine. The only control input that we assume in this paper is blade collective pitch. We apply a constant torque to the generator (we do not perform any generator torque control in this paper) and use blade pitch to regulate turbine rotational speed. The only measured variable is generator rotational speed.

This study differs from previous studies in that we are basing our modeling of turbine blade flexibility on an assumed modes approach, rather than a rigid/blade/tower hinge model. We use Kane's method (as is used in the FAST_AD code) to develop linear equations of motion. This approach gives us the capability to include several blade and tower modes as well as a drivetrain torsion mode in the linear models

* This paper is declared a work of the U.S. Government and is not subject to copyright protection in the United States.

used for control design. In this study, we limit the number of modeled modes to just a few.

In this paper we begin to answer such questions as:

Which turbine modes can be stabilized using only rotor collective pitch (pitch identical for both blades)?

What can be done when only generator rotational speed is measured?

How do wind turbine nonlinear effects influence behavior of the controlled turbine?

What load-alleviating benefits can be gained simply by enhancing modal damping through feedback control?

We develop linear models for a two-bladed turbine using the rotor and generator rotation, drivetrain torsion, and rotor flap DOF. We begin with simple models, based just on generator rotation, and increase the model complexity in steps. We design the controls based on these simple models for a certain operating point and investigate the behavior of the controlled system when the turbine operates at deviations from this point. Where needed, we add further complexity to the control design by adding additional DOF to the linear model. We show simulation results for various cases using FAST_AD⁶. Finally, we draw conclusions and state future studies.

MODEL LINEARIZATION

We based all of our control design on linear control theory, which meant that we needed linear models for a wind turbine. We chose the FAST_AD code early in this study as the platform for simulation of the controlled turbine because DOF can be switched on or off in FAST_AD. We could then design our controls using linear models with just a few DOF. We could then incorporate these controllers into FAST_AD and simulate with the same DOF in the test simulation as used in the controller design. In addition, we could switch on DOF in FAST_AD not included in the linear model to test the effects of unmodeled modes in the controller design.

We developed linear models in symbolic form using a symbol manipulator. We developed symbolic nonlinear equations of motion, based on Kane Dynamics⁷ patterned directly after the algorithm used in FAST_AD. (Note that FAST_AD develops these equations numerically instead of symbolically). The DOF we chose to include in the linear model were a

subset of the same DOF used in FAST_AD. We performed partial differentiation of these symbolic equations with respect to small perturbations in the DOF in order to obtain the mass, damping, and stiffness matrices. We did not include a linear aerodynamic model in these symbolic equations of motion; thus we were unable to obtain aerodynamic damping coefficients symbolically using this method.

We then inserted numerical values into these matrices based on the particular turbine being studied. We determined aerodynamic damping values for the blade by pinging the blade during code execution and examining the resulting blade-tip flap response. We then estimated the aerodynamic flap damping from this response.

Our first linear model only contained the generator rotational degree of freedom. We designed a controller from this model and tested it in FAST_AD. We then progressed to a model with generator rotation, rotor rotation, drivetrain torsion, and rotor first symmetric flap. We did this in steps, designing a controller and testing it in FAST_AD at each step. We neglected the effects of gravity, tower shadow, and wind shear in the control design. We accounted for uniform wind disturbances- across the rotor disk. We also neglected the teeter degree of freedom in this study, because we were only including uniform wind inputs in this model. In this first study, we only wanted to design controls that would account for system modes excited by uniform wind fluctuations over the rotor disk, such as drivetrain torsion and rotor symmetric flap modes. This gave us equations of motion with constant coefficients. Further information on periodic controls for wind turbines is presented in Stol and Balas⁸.

LINEAR STATE EQUATIONS

Each of the linear models that we developed were expressed in state-space form as:

$$\dot{\underline{x}} = A\underline{x} + B\underline{u} + \Gamma\underline{u}_d \quad [1]$$

$$\underline{y} = C\underline{x}$$

where \underline{x} is the state vector, \underline{u} is the control input, \underline{u}_d is the disturbance input, \underline{y} is the measured output, A is the state matrix, B is the control gain matrix, Γ is the

disturbance gain matrix, and C relates the measured output \underline{y} to the turbine states.

These vectors and matrices varied in size depending on the number of DOF in the linear model. For the model with rotor first symmetric flap, drivetrain torsion, and rotor and generator rotational speed (the five states corresponding to this model will be described later), A was 5×5 , \underline{x} was 5×1 , B was 5×1 , and Γ was 5×1 . The variable \underline{y} was always 1×1 because only a single output was being measured, i.e., generator rotational speed.

Elements in A consisted of various combinations of mass, damping, and stiffness terms for the turbine. The elements of B represented the control system gains. For the 5 DOF model, the only nonzero elements in B were the second and third rows. These quantities were the partial derivatives of the blade flap normal force and rotor aerodynamic torque with pitch angle. These gains reflected the capability to control the rotor symmetric flap mode and the rotor aerodynamic torque using blade collective pitch. Because rotor collective pitch was the only control input, the vector \underline{u} had dimension 1×1 .

The dimension of \underline{u}_d was 1×1 because the disturbance was considered to contain only one component of wind speed, the component normal to and uniform across the rotor disk. The only nonzero elements in Γ are the second and third rows (for the 5 DOF model). These elements were the partial derivatives of the blade flap normal forces and the rotor aerodynamic torque with wind speed. These values reflected the influence of uniform wind-speed fluctuations on the rotor symmetric flap mode and the rotor aerodynamic torque.

For the models with fewer DOF, the corresponding matrices and vectors could be determined simply by eliminating rows and columns in those matrices and vectors corresponding to the 5 DOF model.

CONTROL DESIGN

Disturbance-accommodating control (DAC) allows us to regulate turbine rotor speed in the presence of wind-speed disturbances while placing plant poles through full state feedback⁹. It also allows us to use state estimation to provide the controller with values for those states that are not measured. This is important when limited turbine measurements are available. For

the studies included in this paper, the only allowed turbine measurement was generator rotational speed.

The basic idea of DAC is the augmentation of the state-estimator for the turbine with additional states for estimation of the wind-speed disturbances. This means that the original A matrix for the turbine is modified to \overline{A} and now contains terms related to the wind-speed disturbance. In addition, the original C matrix is modified to \overline{C} and now accounts for the output of the wind-speed disturbance estimator. The control law in DAC is assumed in the form of the usual feedback of the plant states as well as feedback of the wind disturbance states⁹. A requirement for successful state estimation using DAC is that the pair $(\overline{A}, \overline{C})$ must be observable.

Another basic idea in DAC is that the wind disturbance gain is chosen to cancel or minimize the affect of wind-speed disturbances. For some of the cases shown in this paper, exact cancellation was possible (as will be later shown), although for other cases, the wind disturbance gain had to be appropriately chosen to minimize the norm of a vector quantity⁹.

For all the controllers designed here, we used only one extra state to estimate the wind-speed disturbance. We assumed that the wind fluctuations were in the form of step functions, as shown in Stol et al.⁵ Figure 1 shows a diagram of the controlled system.

For the results shown in this paper, we designed controls for the two-bladed, AWT27 CR machine described in Buhl et al.¹⁰ Even though the real machine is stall regulated, we used this configuration to study the design of controls to perform speed regulation at full load (region 3) for this machine. We used the physical and operating parameters for the AWT27 CR to compute values for the elements of the A matrix. To compute elements in the B and Γ matrix, we generated tables of machine aerodynamic torque as a function of blade pitch and wind speed, using the FAST_AD code. These curves are shown in Figures 2 and 3 and were generated for the rotor rotating at 53.33 revolutions per minute (RPM). We also generated tables of blade flap normal force versus wind speed and pitch using FAST_AD.

We were able to determine the open-loop natural frequencies of this system by determining the eigenvalues of the A matrix for this turbine. This gave the following open-loop poles for this system: drivetrain torsion: $-0.301 \pm 20.96j$, rotor first symmetric

flap: $-2.53 \pm 16.86 j$, and generator rotation rate: -0.01 . The first symmetric flap mode had a natural frequency of 16.86 radians/second (r/s), while the first drivetrain torsion mode had a frequency of 20.96 r/s.

We designed our first controller based on a linear model having just one degree of freedom: perturbed generator rotational speed. We chose an operating point at a wind speed of 16 meters per second (m/s), generator rotational speed of 53.33 RPM, and a blade pitch angle of 9.5 degrees. We realized that this system was always controllable, provided that the input gain was nonzero. At this operating point, the input gain, which was the partial derivative of rotor torque with pitch, was nonzero (as can be seen from the slopes of the curves in Figure 2). Control becomes very difficult for pitch angles close to 5 degrees, in which the control gain becomes zero (at a wind speed of 16 m/s).

We also confirmed observability of the augmented pair (\bar{A}, \bar{C}) . We then designed the controller so that the closed-loop pole for rotor rotation was chosen at -3 . State and disturbance estimation poles were placed at -24 and -25 .

We simulated this turbine in FAST_AD after implementing this controller. We input only wind normal to, and uniform over, the rotor disk. We excited the system using step changes in wind speed. Figure 4 shows the simulated generator rotational speed and the blade pitch angle, with control beginning at 10 seconds. Step changes in wind speed occurred every 5 seconds after start of control. The figure shows that generator speed was tightly regulated to the 53.33 RPM set point. Blade pitch varied from 9.5 to 14.4 degrees during this control effort.

We wanted to see how well this model estimated wind speed. Figure 5 shows a plot of the actual and estimated wind speeds. In general, their agreement was good. We used constant gains in the design of these controllers, even though the true gains vary with wind speed and pitch. As the turbine's operating point deviated significantly from our control design point, the controller estimated the wind speed less accurately. This could be improved with gain scheduling, which was not included in this study.

Another objective of this research was to study the effects of unmodeled modes in the controller design. We designed this controller with just one DOF (generator speed). We then wanted to study the effect of simulating the controlled turbine with additional

DOF switched on during simulation in FAST_AD. If the simulations showed unstable behavior with additional DOF, then we would need to add these DOF in the linear model used for control design. The most dramatic effect occurred when we simulated this same case with the drivetrain torsion mode switched on in FAST_AD (we neglected this mode in the controller design). As can be seen in Figure 6, the generator speed became unstable, with frequency of oscillations at the drivetrain torsion frequency. We added a large amount of structural damping to this mode in the FAST_AD input file and reran the code, but we found that the response was still not stable.

We proceeded to develop a linear model with additional DOF to account for this mode. This resulted in a 3 DOF model with the three states:

- x1-perturbed rotor rotational speed,
- x2-perturbed drivetrain torsional spring force,
- x3-the perturbed generator rotational speed.

We checked controllability of (A,B) and observability of (\bar{A}, \bar{C}) and found that these matrix pairs were controllable and observable. We designed the controller to have poles at $-3 \pm 20.5j$, -3 . The first pair of poles corresponded to the drivetrain torsion mode, and the third pole corresponded to the generator rotational speed. The state estimator poles were placed at -24 , -24 , and -25 . The extra estimator pole for the wind speed was placed at -25 .

We incorporated this revised controller into FAST_AD and reran the same simulation. Figure 7 shows the simulated generator rotational speed and the blade pitch, confirming that the system is now stable. These results are almost identical to the previous results shown in Figure 4, except that the drivetrain torsion oscillation (at 20.5 r/s) is evident in these responses. These oscillations die out about two seconds after application of the step changes in wind because of the placement of the real part of the poles at -3 . Figure 8 shows the actual and estimated wind speeds for this case, which also are almost identical to the results for the 1 DOF controller model. Drivetrain torsion oscillations are also evident in these results.

We simulated this same case with the blade first flap mode switched on in FAST_AD and simulated using the controller based on the 3 DOF model. Undesirable fluctuations in generator rotation speed can be seen in Figure 9. We added a large amount of structural damping in the first flap mode, but the results with

increased damping looked similar to these results. We turned first flap off and turned on other modes. Simulation using this controller with the blade first edge mode showed some instability, but these results were dramatically improved with the addition of a small amount of structural damping in this mode. Simulation with other modes switched on showed little difference to the results just presented in Figures 7 and 8. We thus decided to extend our linear model to include the first flap degree of freedom for blades 1 and 2.

After deriving linear equations of motion with the first flap mode for blades 1 and 2, we determined that this system was uncontrollable using rotor collective pitch. We made a transformation of coordinates in these equations of motion to rotor first symmetric and first asymmetric flap. These transformed DOF were linear combinations of blade 1 and 2 first flap. Because we were only using rotor collective pitch (pitch is assumed identical for both blades), it was only possible to control the rotor symmetric mode, not the rotor asymmetric mode. We thus deleted DOF corresponding to rotor first asymmetric flap from these equations of motion, resulting in a linear model containing 5 DOF.

For this case, the state vector was:

- x1-perturbed rotor first symmetric flap tip displacement,
- x2-perturbed rotor first symmetric flap tip velocity,
- x3-perturbed rotor rotational speed,
- x4-perturbed drivetrain torsional spring force,
- x5-perturbed generator rotational speed.

We examined controllability of this system in order to do pole placement. We found that nonzero values for the control gains ensured that the system was controllable. If the gain corresponding to the partial derivative of blade flap normal force with pitch was zero, there was still controllability provided that certain coupling terms in the A matrix were present. These terms coupled the rotor first symmetric flap to the drivetrain torsion mode and other DOF. We did not perform control designs for turbine operating points in which this gain was close to zero. At the design points that we chose, elements in rows 2 and 3 of the B matrix had nonzero values, which ensured controllability.

The other issue was observability of the augmented pair (\bar{A}, \bar{C}) . In this case, presence of various coupling terms in the A matrix was more critical because we were using generator rotation speed as the assumed

measurement. This allowed us to use state estimation to estimate the unmeasured states of the linear model. We found that if certain coupling terms were zero, then observability of this system was lost. Typical terms in the A matrix that were important involved coupling terms that were present for nonzero blade pitch angles. This resulted in coupling between the rotor first symmetric flap mode and the other DOF being modeled in this system: rotor rotation, drivetrain torsion, and generator rotation. We chose cases having significant blade pitch angles (of at least 9 degrees). We did not test these results for operating points having small pitch angles, but one would expect that it would take much larger control efforts to meet the stated control objectives than for cases with larger pitch angles.

Having resolved these controllability and observability issues, we proceeded to design a controller from the 5 DOF model having poles at $-3 \pm 16.4j$, $-3 \pm 20.5j$, and -3 . The first pole pair corresponds to the rotor first symmetric flap mode. The second pole pair corresponds to the drivetrain torsion mode. The fifth pole corresponds to the generator-speed degree of freedom. We placed the state estimator poles at -24 , -24 , -25 , -25 , and -25 , and the wind-speed estimator pole at -25 .

We simulated the turbine with this controller for the same case as shown previously. Figure 10 shows the generator speed and blade pitch for this case. Evident in these responses is a damped vibration because of drivetrain torsion coupled with rotor symmetric flap motion. This coupling results from the cross-coupling terms in the A matrix.

This case also presents some differences compared to results using the lower-order controllers. We were unable to regulate rotor speed to the 53.33 RPM set point as accurately as with the lower-order controllers. In this case, the wind-speed disturbances were not exactly cancelled as they were for the previous models. Here we had to choose the wind-speed disturbance gain to minimize the effects of wind-speed disturbances, instead of exact cancellation.

Figure 11 shows the estimated wind speeds for this case. This is also different from the other cases because now the estimated wind speeds are greater than the actual wind speeds when the turbine operating point deviates significantly from the design point. This was also a result of our choice for the wind-speed disturbance gain.

Figure 12 shows the rotor symmetric flap tip displacement. This response is well behaved, because now rotor first symmetric flap is controlled, having added extra damping to this mode from this control design.

OTHER SIMULATION RESULTS

We proceeded to test the controller in simulations with the effects of turbulent winds, tower shadow, and gravity. It was important to test the controlled nonlinear turbine when excited by these unmodeled effects. We generated turbulent winds using the SNLWIND3D code¹¹. We then turned on tower shadow and gravity in the FAST_AD code and simulated 70 seconds of turbine operation inputting the turbulent winds. We used a controller designed from the 5 DOF model for a wind speed of 18 m/s.

Some of our questions were:

Does the system remain stable when excited by turbulent wind, tower shadow, and gravity?

How well does the DAC controller estimate the turbulent winds?

Does increased damping (through pole placement) help to reduce loads?

Figure 13 shows the generator rotational speed. We designed two controllers at the 18 m/s wind speed, one by placing the poles so that the modes had high damping, and the other one so that the modes had light damping. Both results are shown in the figure.

Figure 14 shows the actual and estimated wind speed for the case with high damping. In general, the estimator does a fair job of estimating the wind speed. When the wind speed is above 18 m/s, the model estimates higher wind speeds than actual values, while estimating lower than actual values for wind speeds below 18 m/s. Large differences in the actual and estimated wind speeds are evident when the wind speed drops down below 16 m/s. This is because of the turbine operating point deviating significantly from the control design point. Another effect was a lower limit that we placed on pitch deflections to prevent the turbine from operating close to the point in which the control gain would become zero. These results could be improved with the use of gain scheduling, switching

between different controllers as the wind speeds change.

Figure 15 shows the rotor first symmetric flap displacement. As can be seen from these plots, these turbine states remained stable even while simulating with turbulent winds, tower shadow, and gravity, although significant oscillations due to this mode are evident.

We explored the effects of adding extra damping by the control system. In one case (low damping), the real parts of all the roots were placed at -0.5 , while for the high damped case, these were placed at -3 . As can be seen in Figure 16, the shaft torque variations are smaller for the high damped case. In Figure 13, we also see that the variations in the generator rotational speed are lower for the high damped case. It seems as if designing the controller to add significantly to the damping of these poles decreased the shaft torque variations in this simulation.

CONCLUSIONS

We concluded that it was possible to stabilize the rotor first symmetric flap mode and the drivetrain torsional mode using only rotor collective pitch as the control input for this machine for these cases. By measuring only generator rotational speed, it was possible to use state estimation to estimate the unmeasured states of the model containing the generator and rotor rotational speeds, drivetrain torsion, and rotor first symmetric flap DOF. For this model, various terms in the A matrix, which couple the rotor first symmetric flap mode with the other DOF, were important and ensured observability of the system. These terms had nonzero values for cases in which the blade pitch was nonzero. We chose design cases that had significant nonzero blade pitch angles (at least 9 degrees). We did not include in this study design points with small pitch angles (close to zero), in which the controllability and observability of the system was degraded.

We also saw the effects of the nonlinear behavior of the controlled turbine. We found that the nonlinear aerodynamics of the turbine caused variations of the gains with wind speed and pitch angle. The controller was designed using one set of gains appropriate for a particular wind speed and blade pitch angle. As the turbine's operating point deviated significantly from this design point, the wind-speed estimator became less accurate.

We also tested the effects of turbulent winds, tower shadow, and gravity on the control of the nonlinear turbine. We found for this test case that all turbine states remained stable.

FUTURE WORK

We need to continue work to answer the following questions:

- 1) Which turbine DOF are most important to account for in the control system design?

The answer to this question may differ from the results found in this study, depending on the degree of flexibility of the different components of the turbine. For a turbine with a much more flexible rotor and tower, other modes may be important, such as rotor lag modes and tower fore-aft and side-side modes.

- 2) What effect does the requirement to stabilize various turbine modes have on pitch actuator deflections, rates, and accelerations? How do actuator dynamics and sensor noise affect system behavior?
- 3) What turbine parameters influence controllability and observability of such systems?
- 4) How can we design control systems to account for periodicity? How can we design state estimators and DACs for periodic systems?

REFERENCES

1. Hinrichsen, E.N. (1984). Controls for Variable Pitch Wind Turbine Generators. *I.E.E.E. Transactions on Power Apparatus and Systems*, 103, 886-892.
2. Barton, R.S., Bowler C.E.J., and R.J. Piwko (1979). Control and Stabilization of the NASA/DOE MOD-1 Two Megawatt Wind Turbine Generator. *American Chemical Society*, 1979, pp. 325-330.
3. Mattson, S.E. (1984). *Modeling and Control of Large Horizontal Axis Wind Power Plants*. Ph.D Thesis. Lund Sweden: Department of Automatic Control, Lund Institute of Technology, 1984.
4. Liebst, B.S. (1983). Pitch Control System for Large Scale Wind Turbines. *J. Energy*, 7(2), pp. 182-192.
5. Stol, K., Rigney, B., and M. Balas (2000). Disturbance Accommodating Control of a Variable-Speed Turbine using a Symbolic Dynamics Structural Model. *Proceeding of the 2000 ASME Wind Energy Symposium*, Reno, Nevada, 10-13 January, 2000.
6. Wilson, R.E., Walker, S.N., and P. Heh (1999). Technical and User's Manual for the FAST_AD Advanced Dynamics Code. OSU/NREL Report 99-01. Corvallis, Oregon: Oregon State University, May 1999.
7. Kane, T.R., and D.A. Levinson (1985). *Dynamics: Theory and Applications*. New York: McGraw-Hill Book Company, 1985.
8. Stol, K., and M. Balas (2001). Full-State Feedback Control of a Variable-Speed Wind Turbine: A Comparison of Periodic and Constant Gains. Accepted for *J. Solar Energy Engineering*.
9. Balas, M.J., Lee, Y.J., and L. Kendall (1998). Disturbance Tracking Control Theory with Application to Horizontal Axis Wind Turbines. *Proceeding of the 1998 ASME Wind Energy Symposium*, Reno, Nevada, 12-15 January, 1998.
10. Buhl, M.L., Wright, A.D., and K.G. Pierce (2001). FAST_AD Code Verification: A Comparison to ADAMS. *Proceeding of the 2001 ASME Wind Energy Symposium*, Reno, Nevada, 11-14 January, 2001.
11. Kelley, N.D. (1992). Full Vector (3-D) Inflow Simulation in Natural and Wind Farm Environments Using an Expanded Version of the SNLWIND (Veers') Turbulence Code. NREL/TP-442-5525. Golden, Colorado: National Renewable Energy Laboratory.

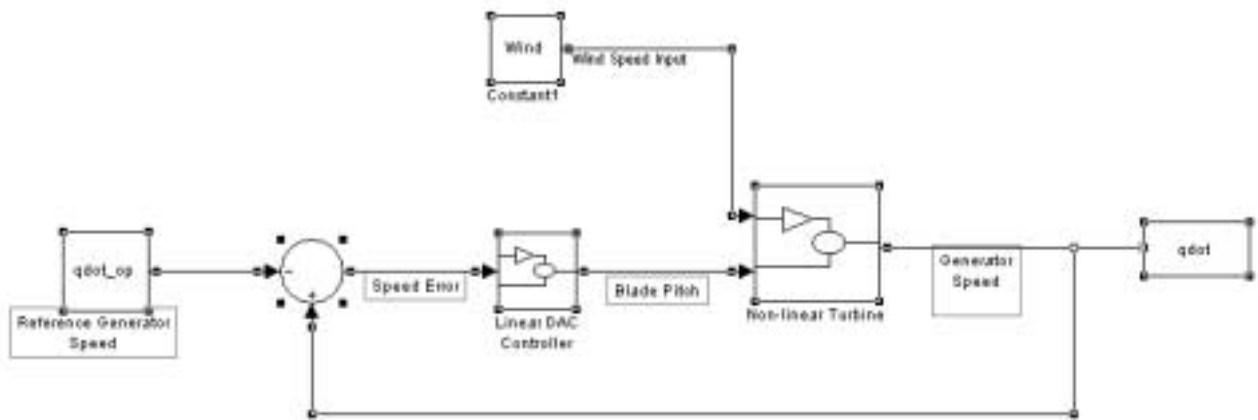

Figure 1. Diagram of Control System.

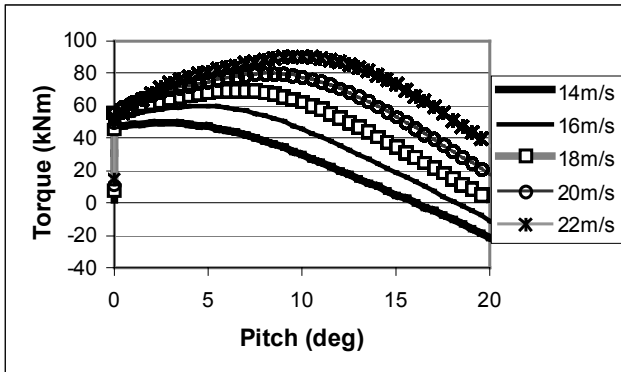

Figure 2. Plot of Rotor Aerodynamic Torque Versus Blade Pitch for Various Wind Speeds.

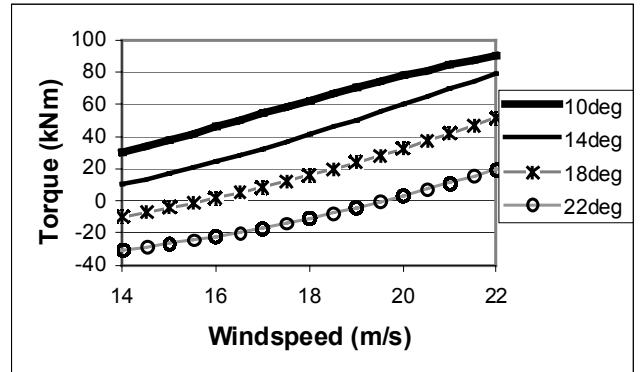

Figure 3. Plot of Rotor Aerodynamic Torque Versus Wind Speed for Various Pitch Angles.

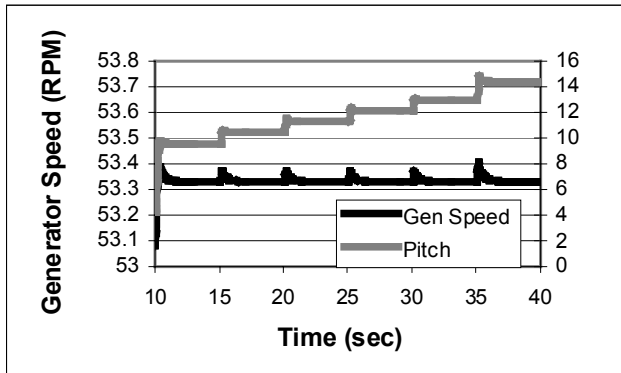

Figure 4. Plot of Simulated Generator Speed and Blade Pitch Using 1DOF Controller Model.

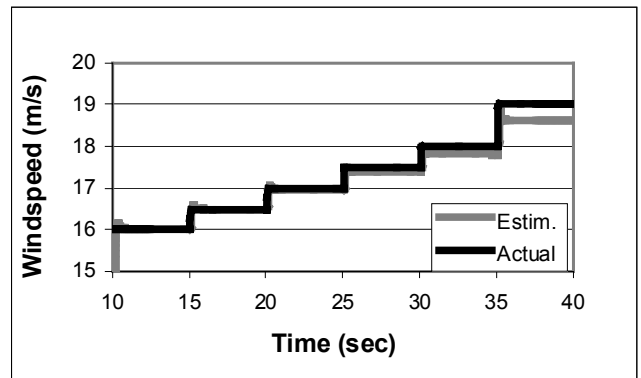

Figure 5. Plot of Actual and Estimated Wind Speeds Using 1DOF Controller Model.

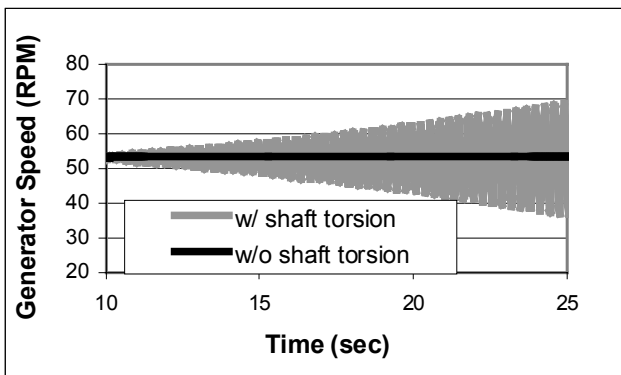

Figure 6. Plot of Simulated Generator Speed With and Without Drivetrain Shaft Torsion Using 1DOF Controller Model.

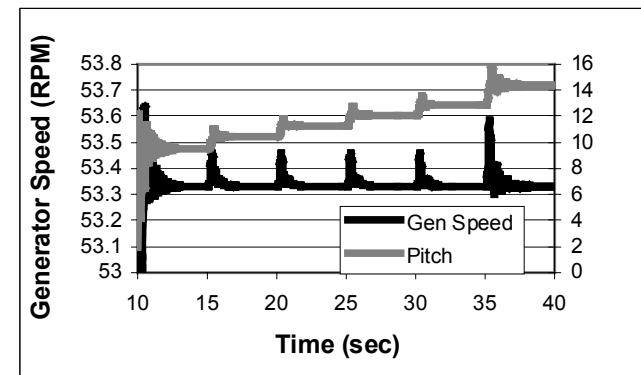

Figure 7. Plot of Generator Speed and Blade Pitch During Control Using 3DOF Controller Model.

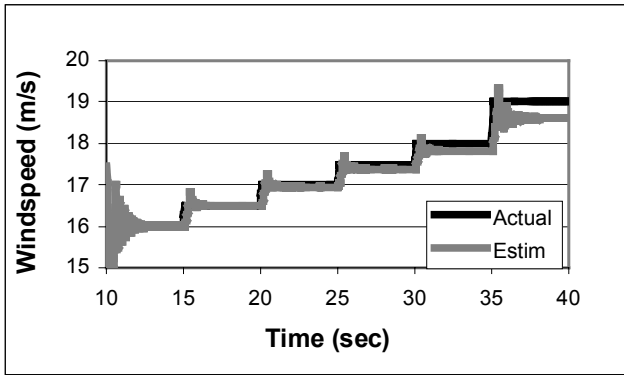

Figure 8. Plot of Actual and Estimated Wind Speeds Using the 3DOF Controller Model.

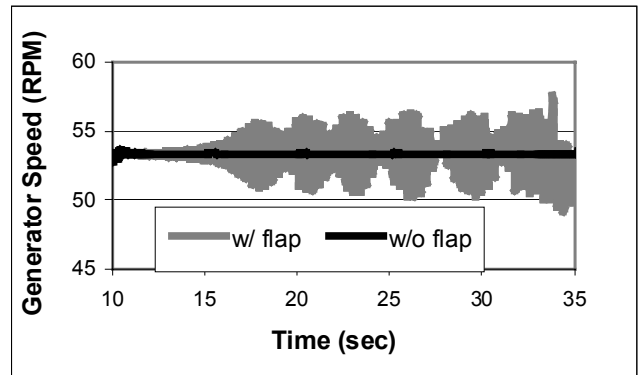

Figure 9. Plot of Simulated Generator Speed With and Without Blade First Flap Using 3DOF Controller Model.

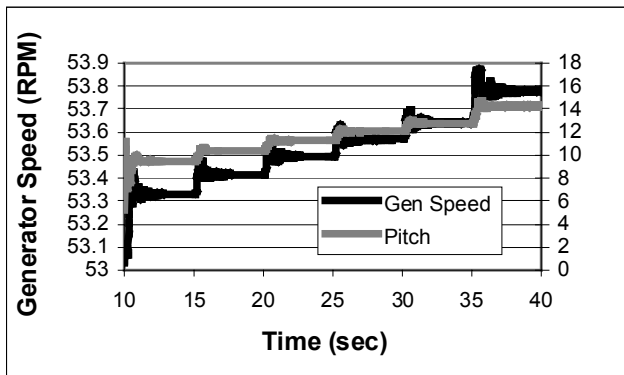

Figure 10. Plot of Generator Speed and Blade Pitch During Control Using 5DOF Controller Model.

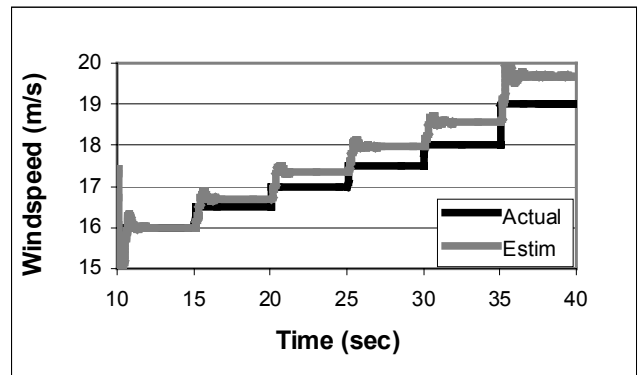

Figure 11. Plot of Actual and Estimated Wind Speeds Using the 5DOF Controller Model.

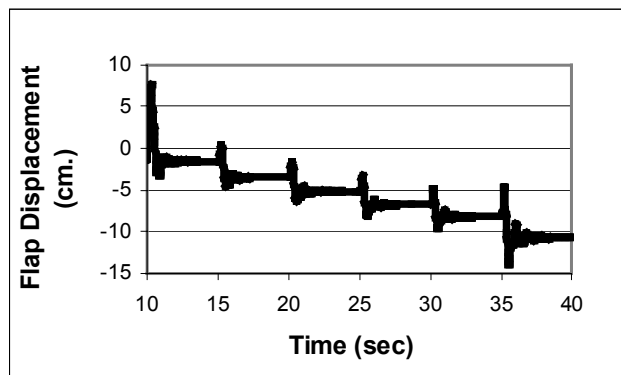

Figure 12. Plot of Blade Tip Flap Displacement During Control Using 5DOF Controller Model.

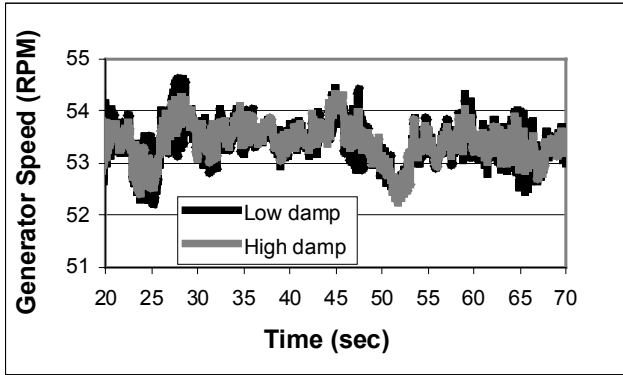

Figure 13. Plot of Generator Rotational Speed with Turbulence, Tower Shadow, and Gravity, Using Controller From 5 DOF Model Designed at 18m/s.

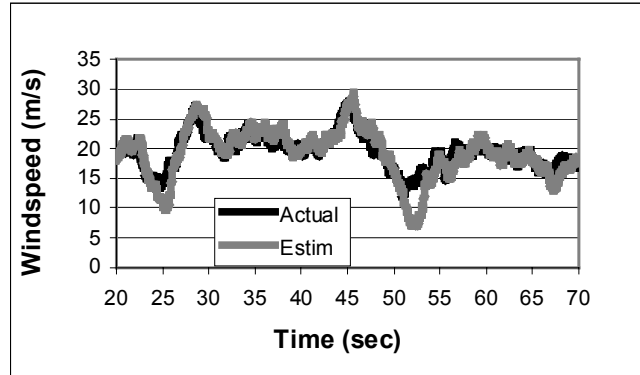

Figure 14. Plot of Estimated Wind Speed for Case with Turbulence, Tower Shadow, and Gravity.

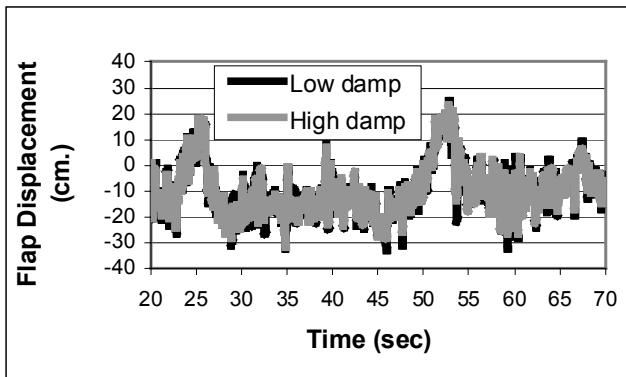

Figure 15. Plot of Blade Symmetric Flap Tip Displacement Case with Turbulence, Tower Shadow, and Gravity.

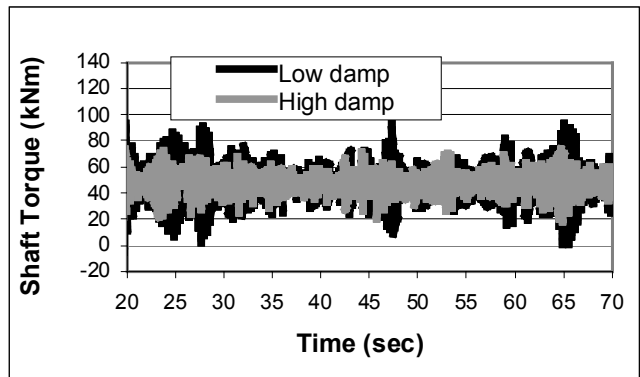

Figure 16. Plot of Shaft Torque for Case With Turbulence, Shadow, and Gravity.

REPORT DOCUMENTATION PAGE			Form Approved OMB NO. 0704-0188
Public reporting burden for this collection of information is estimated to average 1 hour per response, including the time for reviewing instructions, searching existing data sources, gathering and maintaining the data needed, and completing and reviewing the collection of information. Send comments regarding this burden estimate or any other aspect of this collection of information, including suggestions for reducing this burden, to Washington Headquarters Services, Directorate for Information Operations and Reports, 1215 Jefferson Davis Highway, Suite 1204, Arlington, VA 22202-4302, and to the Office of Management and Budget, Paperwork Reduction Project (0704-0188), Washington, DC 20503.			
1. AGENCY USE ONLY (Leave blank)	2. REPORT DATE January 2002	3. REPORT TYPE AND DATES COVERED Conference paper	
4. TITLE AND SUBTITLE Design of State-Space-Based Control Algorithms for Wind Turbine Speed Regulation: Preprint		5. FUNDING NUMBERS TA: WER2.4010	
6. AUTHOR(S) Wright, Alan D.; Balas, Mark J.			
7. PERFORMING ORGANIZATION NAME(S) AND ADDRESS(ES)		8. PERFORMING ORGANIZATION REPORT NUMBER	
9. SPONSORING/MONITORING AGENCY NAME(S) AND ADDRESS(ES) National Renewable Energy Laboratory 1617 Cole Blvd. Golden, CO 80401-3393		10. SPONSORING/MONITORING AGENCY REPORT NUMBER NREL/CP-500-31164	
11. SUPPLEMENTARY NOTES			
12a. DISTRIBUTION/AVAILABILITY STATEMENT National Technical Information Service U.S. Department of Commerce 5285 Port Royal Road Springfield, VA 22161		12b. DISTRIBUTION CODE	
13. ABSTRACT (<i>Maximum 200 words</i>) Control can improve the performance of wind turbines by enhancing energy capture and reducing dynamic loads. At the National Renewable Energy Laboratory, we are beginning to design control algorithms for regulation of turbine speed and power using state-space control designs. In this paper, we describe the design of such a control algorithm for regulation of rotor speed in full-load operation (region 3) for a two-bladed wind turbine. We base our control design on simple linear models of a turbine, which contain rotor and generator rotation, drivetrain torsion, and rotor flap degrees of freedom (first mode only). We account for wind-speed fluctuations using disturbance-accommodating control. We show the capability of these control schemes to stabilize the modeled turbine modes via pole placement while using state estimation to reduce the number of turbine measurements that are needed for these control algorithms. We incorporate these controllers into the FAST_AD code and show simulation results for various conditions. Finally, we report conclusions to this work and outline future studies.			
14. SUBJECT TERMS wind turbines; control algorithms; rotor speed; FAST_AD code		15. NUMBER OF PAGES	
		16. PRICE CODE	
17. SECURITY CLASSIFICATION OF REPORT Unclassified	18. SECURITY CLASSIFICATION OF THIS PAGE Unclassified	19. SECURITY CLASSIFICATION OF ABSTRACT Unclassified	20. LIMITATION OF ABSTRACT UL