

Design of the Scarab Rover for Mobility & Drilling in the Lunar Cold Traps

Paul W. Bartlett, David Wettergreen, William Whittaker
Carnegie Mellon University
paulbartlett@cmu.edu

Abstract

Scarab is a demonstration of a lunar rover design to explore polar cold traps for water ice as a potential resource. The envisioned mission scenario lands the rover on the floor of a permanently shadowed crater. The radioisotope powered rover then traverses kilometers in darkness, stopping to drill into the near subsurface and take data. The vehicle design employs a passive kinematic suspension with an active adjustability to lower for drilling and aid in driving. Scarab was designed and built in 2007 and is currently in lab and field testing and further development.

1. Introduction

Upcoming robotic and human missions to the moon will likely involve the polar cold traps. These regions of permanent shadow may harbor useful amounts of water ice and other resources [1], and they lie near areas of permanent sunlight. Such attributes would suit long term presences and the support of missions continuing to Mars and elsewhere. Proving the presence of in situ resources, characterizing and utilizing these regions will necessitate early exploratory missions. The operational environments and tasks make for a challenging set of requirements for the design of the surface vehicle.

To adequately survey the floor of a shadowed crater the vehicle must provide mobility over the scale of tens of kilometers through regolith slopes and rock fields. Due to the nearly absolute darkness the vehicle must navigate through this terrain using unique sensing methods. And to perform the exploratory tasks, the vehicle must support a payload of instrumentation and, most likely, a drilling system to acquire subsurface samples for analysis.

A team at Carnegie Mellon University's Field Robotics Center is developing the Scarab rover to answer to these requirements, in collaboration with the NASA Glenn Research Center, Ames Research Center, Johnson Space Center, and the Canadian Northern Centre for Advanced Technology (NORCAT).

The vehicle development project began with a study of mission requirements and an extensive study of vehicle configurations. The configuration study started at the level of basic mobility methods, extended into variations and components, and assessed possible solutions with systems engineering and flight feasibility in mind.

After a series of design reviews a final configuration was chosen and design of the field demonstration unit began. The aim of the field unit is to demonstrate the mobility approach and the accommodation of drilling, as well as to serve as a facility for the development of dark navigation and localization techniques, and for the demonstration of integrated payloads on a mobile platform in the field.



Figure 1: The Scarab rover

In the summer of 2007 the primary integration of Scarab, as seen in Figure 1, was completed. Field experiments and laboratory characterization are currently underway, along with continued hardware and software development. This paper summarizes the Scarab design, the path leading to it, and early results.

2. Mission Scenario

The mission assumptions used to guide Scarab's design were taken from the output of study groups such as the Lunar Architecture Teams, and

communication with the lunar In Situ Resource Utilization (ISRU) and science communities. The NASA ISRU roadmap from 2005 offers a thorough summary of the goals and needs of that community [2].

The envisioned mission will land a mobile robotic surface vehicle in the floor of a permanently shadowed crater with promise of harboring water ice such as Shackleton Crater at the South Pole. All surface operations are assumed to take place within the permanent shadow, with communication to Earth relayed by a spacecraft in lunar orbit.



Figure 2: SMART-1 image of Shackleton crater

The goal of the mission is to search for direct evidence of water ice in the near subsurface regolith and observe its nature and distribution if it is present. Other physical and chemical properties of the near subsurface would likely be characterized along with water in support of later construction and ISRU missions.

The most likely means of performing direct in situ sensing in the near subsurface is drilling. Such an exploration mission would require multiple drill and drive cycles over distances on the order of kilometers, in the interest of searching for water and characterizing the crater floor. On the order of 25 drill sites would be required to achieve a proper areal distribution of sensing sites on the crater floor.

Due to the permanent shadow, radioisotopic power is baselined as opposed to solar power. A next generation Radioisotopic Thermoelectric Generator (RTG) such as an Advanced Stirling Radioisotopic Generator (ASRG) [3] would provide a continuous supply of roughly 100 W_e. The heat that is not converted to electric power would be used to heat the vehicle given ground temperatures as cold as 40 Kelvin and a constant sky temperature of 3 Kelvin.

Another consequence of permanent shadow is the need for active sensing for navigation as opposed to passive means such as imaging using ambient light. Flash systems and laser scanning systems are likely solutions that would allow the vehicle to build terrain maps, choose paths and avoid obstacles.

The Scarab design is an investigation in satisfying the above requirements and providing highly capable mobility in the 250 kg vehicle class.

3. Path to Vehicle Design

At the outset of the design process the team researched past vehicles heavily and started at first principles in order to arrive at a configuration that would suit the requirements. Among the flight vehicles referenced were the Apollo Lunar Roving Vehicles (LRV), the Soviet robotic Lunokhod rovers, and the Mars Exploration Rovers (MER).

3.1 Vehicle Taxonomy

The effort to start from first principles took the form of a graphical taxonomy, as seen in Figure 3 below, representing possible mobility approaches. Classes of mobility are broken into continuous motion, discrete motion and hybridizations of the two.

The continuous motion class consists of wheeled and non-wheeled approaches, such crawling, tumbling and tracked vehicles. The discrete motion class consists of walking and jumping approaches. Other options are presented for ways of articulating the vehicle body or suspension, and for the inclusion of devices and aids to address driving and drilling issues. Development on rappelling robots [4] and on a tracked vehicle employing a plow mechanism that is driven into the soil for greater control authority [5,6] showed promise for Scarab's design scenario. Not shown are additional sections of the taxonomy that break down wheel types, track types, suspension types and other design attributes on that level.

3.2 Down selection

The process of down selection to a final configuration was guided by three main motivations:

1. Simplicity of design and control
2. Stability on rough terrain and steep slopes, and
3. Suitability for drilling

Pruning of the tree was attempted from the top down. Discrete motion was pruned as a whole due to the complexity of control of walking and jumping robots. Continuous motion and hybridizations then remained. Among the options, articulated bodies were discounted due to the difficulty of distributing heat across articulations. Drag mechanisms and other aids were kept only as potential inclusions if they were found to be necessary.

The key high-level trades then became wheels versus tracks and whether a mode-changing suspension could satisfy the requirements and the guiding motivations.

LUNAR VEHICLE DESIGN TAXONOMY

CONTINUOUS MOTION

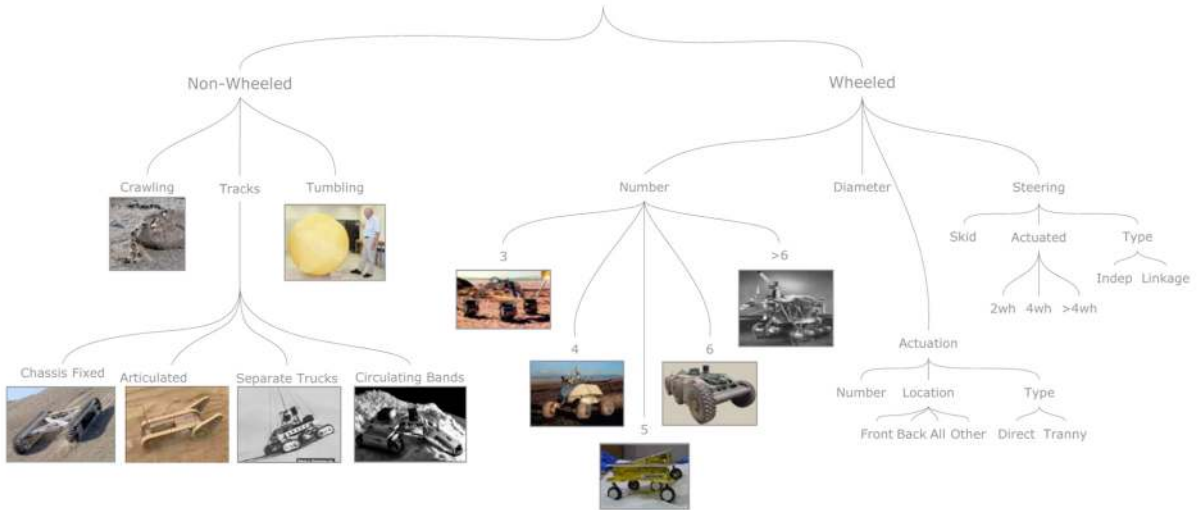

DISCRETE MOTION

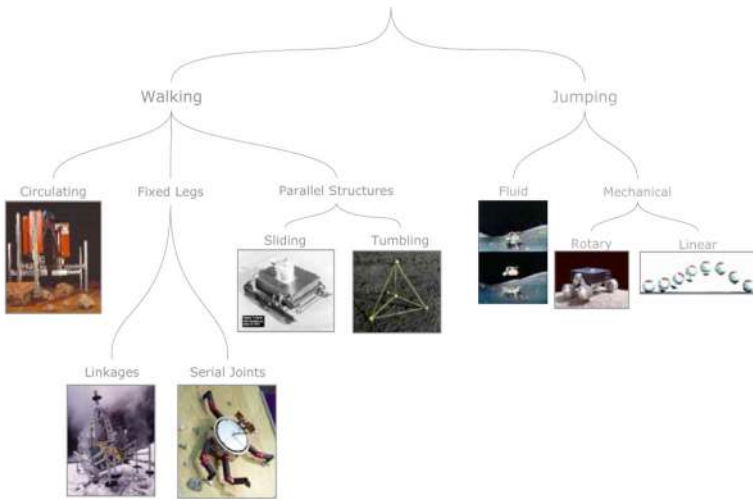

HYBRIDIZATIONS

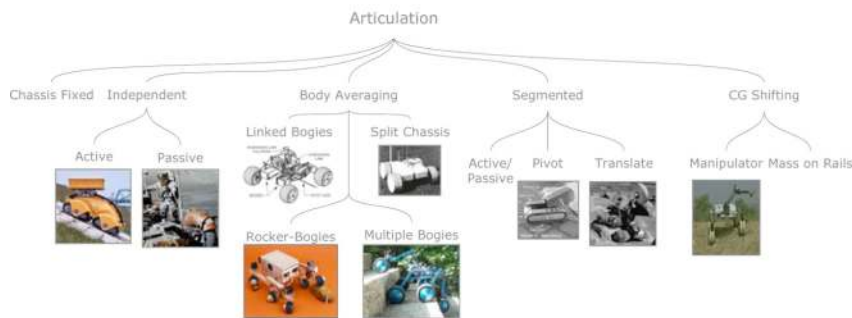
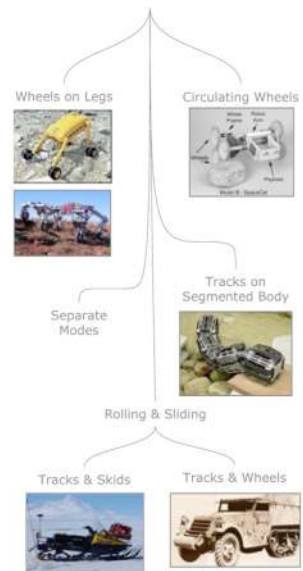

Figure 4: Taxonomy of possible vehicle types and design options (previous page)

Standard tracked vehicles and multiple variants were researched and in the end wheels were chosen over tracks due to reliability and energy efficiency, despite some mobility benefits. The reliability issue includes the risk of a track derailing but more importantly the construction and function of the track for lunar cold trap application. Reliable solutions are proposed for hinged plates and flexible material versions but they lacked in maturity of development in comparison to wheels.

Spring and damper suspensions, with and without mode changing capabilities, were investigated until the driving physics was better assessed. Since the mission scenario allows for traverse rates on the order of 5 cm/s, and since the vehicle mass and lunar gravity are relatively low, it is possible to apply the assumption of quasi-static operation. This assumption let kinematic suspensions be considered instead of dynamic suspensions. Benefits of kinematic suspensions for this application are simplicity, stiffness, and more efficient distribution of weight.

The number of wheel was chosen to be four in the interest of reducing degrees of freedom while maintaining a large stability pyramid base. Since four wheels over-define a surface, one degree of freedom needed to be introduced as a passive release. Multiple differencing degrees of freedom were investigated, where a joint is free but only when the two sides of the joint rotate in opposite directions. Some of the versions resulted in reduced contact polygons, including reductions from rectangular to triangular, which would have greatly diminished vehicle stability. A configuration was chosen where right and left wheel pairs are on rockers that are connected across the body by a differential joint. The type of differential was then investigated, weighing geared versus linkage approaches. A simple geared differential would have tubes running through the center of the body, where the drill system is to be mounted. A simple linkage could bypass the drill volume however, running along the roof of the vehicle offset from the center. The linkage approach also provided higher stiffness than most geared implementations, and the geometry of the right and left suspensions ended up accommodating a linkage easily.

The last trade concerned lowering the drill to the ground, either with a dedicated mechanism or by lowering the vehicle body using the suspension. Lowering mechanisms were either complex or swept large volumes. Using the suspension made the interface between the drill and the chassis static, which

is beneficial for structural stiffness, simplicity, and cabling. It also became clear that the mobility benefits of an adjustable pose suspension could be significant.

4. Final Vehicle Configuration

The following sections describe the design and fabrication of Scarab, with an emphasis on the configuration level and mechanical aspects.

4.1 Design

Scarab's design, especially in its actuations, follows a doctrine of being reliable, strong and slow -- living off of a small but constant supply of power and heat. The rover is thought of as a serial work machine, where in the course of its mission it would drive, charge its batteries, drill, charge and repeat.

The rationale for the vehicle weight and size class was based on the ~1 m long, ~3 cm diameter drill class that is likely to be employed in such a mission. Not only does the vehicle have to package the drill system within it but also it must provide sufficient weight on the lunar surface against which the drill can react its downward thrust while it operates. Drill thrusts could be expected to reach 100-200 N or more. As built, Scarab has a mass of roughly 280 kg and a footprint of roughly 1.5 by 1.5 meter.

Drilling also requires a very stiff platform for reliable operation, into which thrust loads, torques and vibrations are transmitted. Placement of the drill in line with the vehicle's center of gravity maximizes the weight available. Bolting directly to a high stiffness, high strength chassis maximizes the stability of the platform. A fixed drill structure configuration was chosen due to the stiffness and reduced actuations, and since the vertical structure can also support navigation sensors. This dual purpose comes from the need for the drill to be upright when the vehicle is at a sampling site, and for a navigation mast to be upright when the vehicle is driving. A flight implementation may require a single use deployment actuation depending on stowing requirements.

The basic design decisions for mobility were to achieve a low center of gravity for stability, to use skid steering as opposed to explicit steering, and to employ an adjustable kinematic suspension. Skid steering was favored due to the simplicity it affords the system and the precedence for it on the Soviet Lunokhod rovers. The passive, differenced rocker suspension matches the wheels to high roughness terrain, evenly distributes weight among the four wheels, and creates a large rectangular base for the vehicle's stability pyramid.

The differencing effect of the linkage connecting the left and right suspensions can be described as *body averaging*. As one side pitches up the other pitches down by the same amount relative to the body. The body's pitch angle is then the average of the two. While traversing the body pitches considerably less than it would otherwise. In order to maintain a belly clearance of 30 cm while the body pitches, the underbody took a scalloped shape. Figure 4 shows the reference case of one wheel on top of a 30 cm rock and the underbody clearance being maintained.

Active adjustability of the suspension allows for changing the body height so the drill can be brought near to the surface for its operation. The nominal, high, and low ride height poses are shown in Figure 5. The adjustability was devised as independent of the passive differencing. In this way, the two linked attributes of wheelbase and body height can be adjusted independently on either side of the vehicle, making it possible to lean the body.

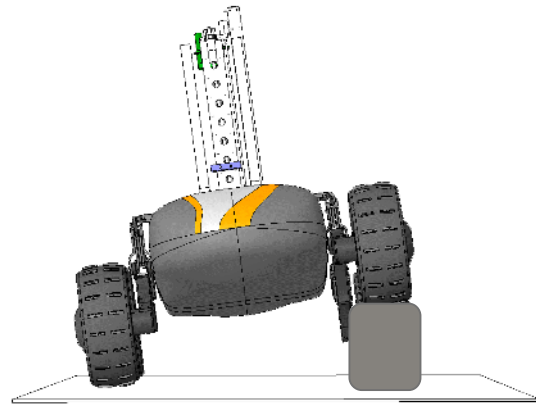

Figure 4: Differencing & body clearance

A similar combination of passive suspension with active adjustability was used in NOMAD, which was able to adjust its footprint [7]. Though on a different scale, the kinematics for Scarab turned out to be very similar to the Jet Propulsion Laboratory's Sample Return Rover (SRR) [8]. As some have shown [9], such an adjustable suspension can be effective at improving stability along traverses. Other mobility benefits are becoming apparent as well.

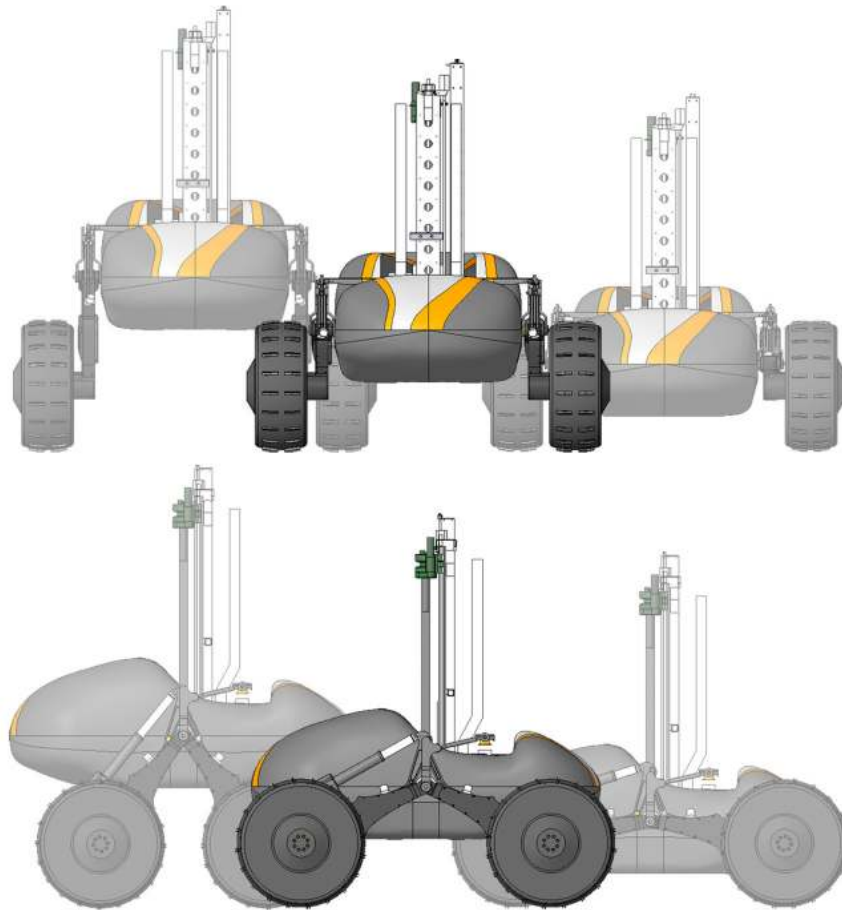

Figure 5: High, nominal and low ride heights

Each of the four wheels is directly and independently driven. A brushless motor, planetary gearhead, and harmonic drive are embedded at the hub. The total gear reduction is currently 400:1. The rim pull for one wheel was designed to approach the full vehicle weight.

The suspension adjustment is done by a five bar doubler linkage driven by an electric linear actuator. The linkage is similar to those used to pitch backhoe buckets through large angles. The linear actuator sits above one of the arms of the suspension, and the small links of the five bar linkage are located above the pivot for the suspension arms. A flight implementation would likely use a rotary actuator for sealing and available stroke.

Power is supplied by an ASRG simulator, which can support untethered operation for periods of time. There are 24 V and 48 V buses, distributed motor controllers, a PC-104 computer, and wireless communication and wireless remote control.

Localization and navigation will use wheel odometry, an Inertial Measurement Unit, and terrain sensing via active devices such as laser scanners. GPS is used for vehicle pose knowledge for early tests and later will serve as ground truth for the pose estimator software.

Due to the unique thermal environment in the lunar cold traps, it was important to arrive at a first order thermal design approach for the vehicle. Considering the waste heat from the radioisotope power supply, the hard vacuum, 40 Kelvin ground temperature and constant 3 Kelvin sky, simple thermal balance analysis suggests that while the waste heat could be used to maintain acceptable temperature ranges for electronics and other components, excess heat would need to be shunted to a radiator surface. A thermal management system would distribute heat and control temperatures. It would be likely to have some electrical heating of outboard components. Thermal paths would need to be minimized to parts of the drill or anywhere icy soil samples would be in the vehicle so the volatile samples are preserved.

4.2 Fabrication & Integration

Scarab's aluminum weldment chassis forms the high stiffness structure spanning between the suspension pairs and providing a mount for the drill system. At its center, the chassis is hollow so that it wraps around the drill's workspace. Structure supporting the drill continues upwards from the chassis to serve as the navigation sensor masts. Much of the electronics are integrated to the chassis, allowing them to be independent of the body and to dump heat into the central void in the rover. The underbody bolts to

the chassis and the upper body shells attach to the underbody with embedded magnets. Since the underbody can take loads by contacting the terrain it was structurally reinforced, while the upper body shells serve as housings. The differencing linkage connecting the two sides of the suspension is also carbon fiber composite.

The majority of the suspension components are machined 7075 aluminum. The first iteration wheel is a tubeless rubber skid loader tire mounted on a machined hub. When a wheel development effort is possible the rubber tires would likely be replaced by a more flight-like metal design.

The Scarab development benefits from multiple collaborations. A power supply that electrically simulates an ASRG has been furnished by NASA GRC. Payload guidance and the opportunity to design around and integrate with a breadboard coring drill have been furnished by the RESOLVE team at NASA JSC and NORCAT. Rover sensing and navigation techniques are being co-developed at NASA ARC.

When the drill system is not available, Scarab is outfitted with a static stand-in that replicates its mass properties.

4.3 Specifications

Characteristics of the field vehicle in its current state are collected in Table 1 on the following page. Where pertinent, measurements are provided with the drill system or a mass model stand-in present. The planar location of the vehicle's center of gravity was measured and adjusted to be on center. The height of the center of gravity and the static tip-over angles were found empirically with the vehicle on a tilt table. The tilt-table setup is shown in Figure 6, with the vehicle near the angle of static tip-over.



Figure 6: Tilt-table characterization

In the specifications, the term "pitch-over" refers to the vehicle tipping forward or backward while the term

“roll-over” refers to tipping side to side. With Scarab these attributes are symmetrical.

Table 1: Vehicle specifications

Drill tower (upright):	2.2 m high stance, 1.6 m low stance
Mass:	280 kg
Weight:	2740 N Earth surface 450 N Lunar surface
Average power available:	100 W
Nominal power:	175 - 200 W
Idle power:	24 W
Locomotion speed:	3 - 6 cm/s
Wheel diameter:	65 cm
Track width:	1.4 m
Wheelbase:	0.8 - 1.4 m 1.2 m nominal
Aspect ratio:	1:1.0 low stance
(track/wheelbase)	1:1.2 nominal stance 1:1.7 high stance
CG planar location:	On geometric center
CG height:	0.48 m low stance 0.64 m nominal stance 0.74 m high stance
Static pitch-over:	56° low stance 43° nominal stance 30° high stance
Static roll-over:	61° low stance 53° nominal stance 49° high stance
Maximum straddle:	55 cm
Minimum straddle:	Belly contact
Approach,departure angle:	105° nominal stance
Breakover angle:	115° nominal stance

5. Early Performance

The following sections summarize early rover performance characterized through the Fall of 2007.

5.1 Mobility

In the laboratory, drawbar pull tests characterized the strength and traction of the rover. With the rubber skid loader tires in place, Scarab pulled 2,000 N in mixed grain sized sand, which is approximately 0.7 x vehicle weight, and 2,700 N on concrete pavement, which is approximately equal to vehicle weight. Similar tests are planned where lunar gravity is simulated with an off-loading system.

In the field, Scarab has demonstrated skid steering in arc turns of varying curvature, as well as point turns.

Point turning is possible at a large range of poses, where the wheelbase changes considerably.

On a pure geometry twist course, the differencing effect of the suspension was readily apparent. The twist course consisted of two saw tooth wave form ramps, one for the right wheels and one for the left, positioned out of phase by 1/2 period. Since the period of the wave was equal to the wheelbase, the suspension sides rocked opposite each other and held the body level through the course. Figure 7 shows the suspension differencing clearly, where the side frames are rocked relative to each other, matching the wheels to the terrain.



Figure 7: Suspension conforming to terrain

In field testing, the vehicle has performed a long continuous traverse of 1 km, roughly the distance it would cover between drill sites during a mission. Scarab has also encountered a range of terrain such as slopes of varying grade and craters on the order of 5 m in diameter formed with loose, mixed grain size slag. Scarab is able to climb rock obstacles of 40-50 cm height, with a range a shapes.

Mobility on slopes can be aided by the rover's ability to lean, as seen in Figure 1. Attempting to hold a straight cross-slope path for 11 m on a 20-25° slag slope, Scarab experienced 15% downhill slip without leaning, and 7% with leaning into the slope. This decrease in slip is due to shifting of the vehicle's weight vector, which returns weight to the uphill wheels, and the edging effect of the wheels plowing terraces in the slope as opposed to skiing with the contact patches parallel to the slope face. On a steeper

slope that would otherwise be an impasse, these effects can be used to achieve a spiral or switch-back ascent.

On a torture course simulating very rough terrain using railroad ties and slag, the suspension's ability to distribute weight evenly to the wheels and the significant available wheel torque were demonstrated. Scarab cleared the course with acceptable amounts of slip and uncommanded yaw motion. Scarab was able to bridge a trench constructed by two railroad ties with a gap of 50 cm.

Another use of the adjustable suspension for mobility purposes is clearing a high-centered condition. It is possible for the rover to inadvertently high-center on the terrain, sense the state it is in, raise the ride height to clear the feature, and drive off of it.

5.2 Drilling

NORCAT's coring drill breadboard unit has been integrated onto Scarab and operated in a lunar soil simulant. The drill system was able to drill successfully to the full depth of 1 m. Since the loads induced during these tests are relatively moderate, Scarab will be characterized in terms of stability over the full range of anticipated loads. To make the loading conditions flight-like, a gravity off-loading system will simulate the vehicles reduced weight on the lunar surface. Work is also underway on remotely selecting drill sites and having the rover accurately reach and place the drill at the site.

6. Current & Future Work

Near term developments on Scarab will focus on sensing and software, along with the continuation of lab characterization and field testing. Sensing tasks underway or planned include implementing laser scanners and light stripers for building terrain meshes, and downward looking imagers for aiding pose estimation via optical flow measurements. Software development will include rover pose estimation, path planning and hazard avoidance.

Possible further term developments include mobility algorithms, crater analog site field testing, and hardware additions and modifications. Mobility tasks could include autonomous body roll leveling and traction control. Hardware modifications could include the development of metal wheels, variable gear transmission wheel drive actuators, and the accommodation of more of the RESOLVE sensing payload to demonstrate in situ processing and sensing of core samples onboard the rover.

Throughout the work on Scarab, the successfully demonstrated design attributes are feeding into a

matured vehicle concept, readying it for a mission implementation in the coming decade.

7. Acknowledgments

The authors would like to acknowledge the Scarab team at Carnegie Mellon's Field Robotics Center. The work described here was supported by NASA's Human & Robotic Systems and In Situ Resource Utilization programs in coordination with NASA Glenn Research Center, NASA Johnson Space Center, NASA Ames Research Center, as well as NORCAT & the Canadian Space Agency.

8. References

- [1] Spudis, P., "Ice on the Moon", *The Space Review*, 6 Nov. 2006.
- [2] Sanders, G.B., Chair, "NASA In-Situ Resource Utilization (ISRU) Capability Roadmap Final Report", 19 May 2005.
- [3] Shaltens, R.K., Wong, W.A., "Advanced Stirling Technology Development at NASA Glenn Research Center", *NASA/TM 2007-214930*, Glenn Research Center, Cleveland, OH, Sept. 2007.
- [4] Huntsberger, T., et al., "Integrated system for sensing and traverse of cliff faces", *SPIE Aerosense '03*, Orlando, FL, 21 April 2003.
- [5] Ziglar, J., et al., "Technologies toward Lunar Crater Exploration", *Tech. Report CMU-RI-TR-07-40*, Robotics Institute, Carnegie Mellon University, 22 April 2007.
- [6] Kohanbash, D., et al., "Plowing for Controlled Steep Crater Descents", *i-SAIRAS*, Los Angeles, CA, Feb. 2008.
- [7] Apostolopoulos, D.S., "Analytical Configuration of Wheeled Robotic Locomotion", *Thesis CMU-RI-TR-01-08*, Robotics Institute, Carnegie Mellon University, April 2001.
- [8] Schenker, P.S., et al., "New Planetary Rovers for Long Range Mars Science and Sample Return", *Intelligent Robots and Computer Vision XVII, SPIE*, Boston, MA, Nov. 1998.
- [9] Iagnemma, et al., "Mobile Robot Kinematic Reconfigurability for Rough-Terrain", *Proceedings of the SPIE Symposium on Sensor Fusion and Decentralized Control in Robotic Systems III*, Boston, MA, Sept. 2000.