



Nov 24th, 12:00 AM

Design Recommendations for Steel Deck Floor Slabs

Max L. Porter

C. E. Ekberg Jr.

Follow this and additional works at: <https://scholarsmine.mst.edu/isccss>



Part of the [Structural Engineering Commons](#)

Recommended Citation

Porter, Max L. and Ekberg, C. E. Jr., "Design Recommendations for Steel Deck Floor Slabs" (1975). *International Specialty Conference on Cold-Formed Steel Structures*. 8. <https://scholarsmine.mst.edu/isccss/3iccfss/3iccfss-session3/8>

This Article - Conference proceedings is brought to you for free and open access by Scholars' Mine. It has been accepted for inclusion in International Specialty Conference on Cold-Formed Steel Structures by an authorized administrator of Scholars' Mine. This work is protected by U. S. Copyright Law. Unauthorized use including reproduction for redistribution requires the permission of the copyright holder. For more information, please contact scholarsmine@mst.edu.

DESIGN RECOMMENDATIONS FOR STEEL DECK
FLOOR SLABS

M. L. Porter* and C. E. Ekberg, Jr.†

INTRODUCTION

Cold-formed steel deck sections are used in many composite floor slab applications wherein the steel deck serves not only as the form for the concrete during construction, but also as the principal tensile reinforcement for the bottom fibers of the composite slab. The term "composite steel deck floor slab" is applied to systems in which the steel deck has some mechanical means of providing positive interlocking between the deck and the concrete. An example is shown in Fig. 1.

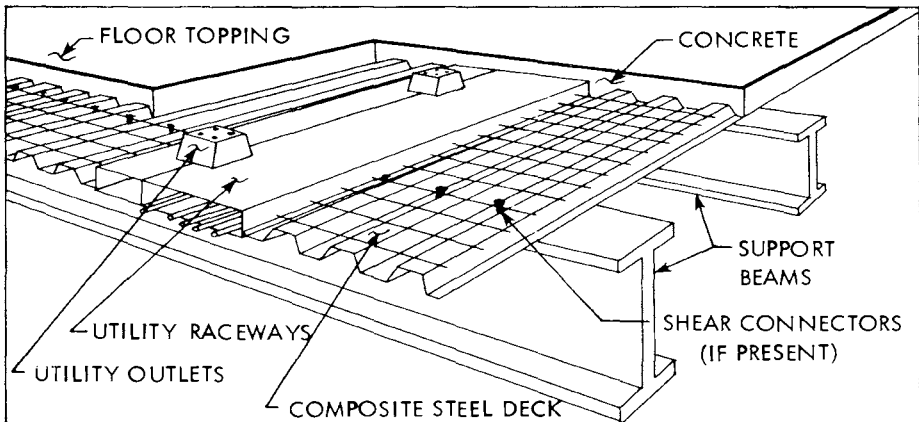

Fig. 1. Typical building floor construction utilizing cold-formed steel decking with composite support beams.

*Assistant Professor, Dept. of Civil Engr., Iowa State Univ., Ames, Iowa

†Professor and Head, Dept. of Civil Engr., Iowa State Univ., Ames, Iowa

The mechanical means of positive interlocking between the deck and the concrete is usually achieved by one of the following:

- 1) Embossments and/or indentations,
- 2) Transverse wires attached to the deck corrugations,
- 3) Holes placed in the corrugations, and
- 4) Deck profile and steel surface bonding.

Figure 2 gives examples of composite steel decks which utilize each of the above-listed means of composite interlocking. The mechanical interlocking and/or deck profile must provide for resistance to vertical separation and to horizontal slippage between the contact surface of the steel and concrete. Additional composite action may be achieved between the composite steel deck floor slab and the support beams by attaching studs or similar shear devices (see Fig. 1).

Steel deck profiles generally are classified as two types, namely cellular and non-cellular deck (see Fig. 3). Cellular decks differ from non-cellular ones in that the cellular deck profile has closed cells formed by an added sheet of steel connected to the bottom corrugations of the deck. The closed cells are often used for electrical, communication, or other utility raceways within the floor system. In some instances, utility raceways are blended with the composite deck profiles (see Fig. 1).

This paper primarily discusses proposed design criteria for composite steel deck reinforced slab systems.* A description of the applicable failure modes, of the performance test procedures, and of the

* These proposed design criteria are presented in the American Iron and Steel Institute's latest draft of "Tentative Recommendations for the Design of Composite Steel Deck Slabs" and Commentary.

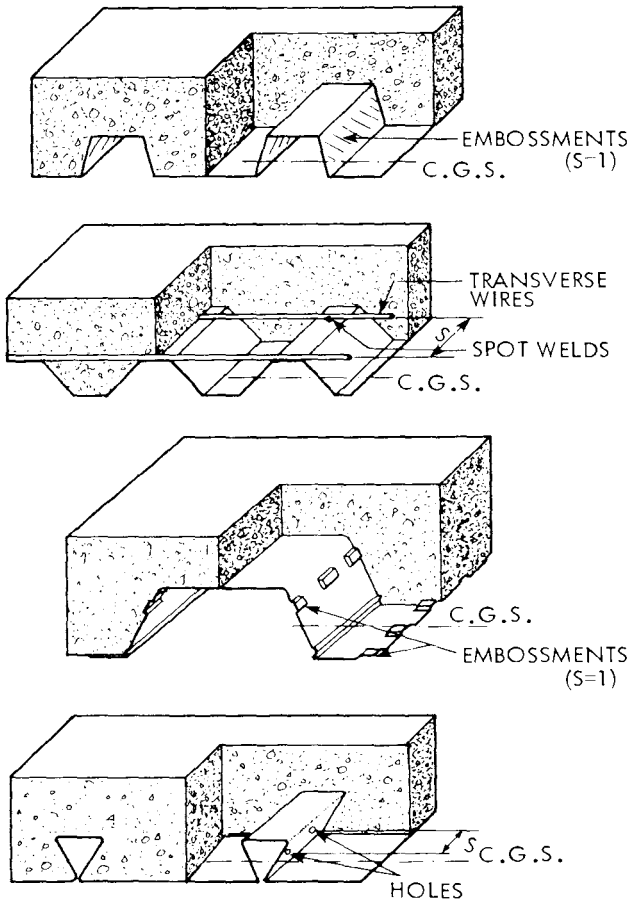

Fig. 2. Examples of composite steel-deck floor slab systems.

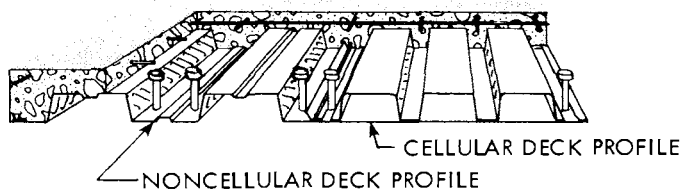

Fig. 3. Illustration of a typical cellular and noncellular type of deck profile.

necessary design equations and considerations are presented. Another paper, presented by T. J. McCabe, at this Specialty Conference gives a complete design example.

DESCRIPTION OF FAILURE MODES

The design of steel deck reinforced slab systems is based on the load-carrying capacity according to the governing failure mode. The following failure modes are of primary importance for design:

- 1) Shear-bond,
- 2) Flexure of an under-reinforced section, and
- 3) Flexure of an over-reinforced section.

An extensive theoretical and experimental research program was undertaken at Iowa State University under the sponsorship of the American Iron and Steel Institute to investigate the design recommendations and behavioral characteristics of the above failure modes. A total of 353 specimens were tested to determine strength properties. See Refs. 6 and 8. These tests, along with numerous proprietary tests, indicate

that the shear-bond mode of failure is the one more likely to occur for most steel deck slabs. Additional information concerning the analysis and the behavioral characteristics of the test results is contained in Refs. 3, 4, 5, 7, 10, 11.

The shear-bond mode of failure is characterized by the formation of a diagonal tension crack in the concrete at or near one of the load points, followed by a loss of bond between the steel deck and the concrete. This results in slippage between the steel and concrete which is observable at the end of the span. The slippage causes a loss of composite action over the beam segment taken as the shear span length, L' . Physically, the shear span is the region between the support reactions and the concentrated load.

Slippage usually occurs at the time of reaching the ultimate failure load, V_e , and is followed by a significant drop in loading (if hydraulic loading is used). Figure 4 indicates a typical shear-bond failure showing cracking and the associated end slip. End slip normally occurs on only one end of the specimen and is accompanied by increased deflections and some creep. Some systems exhibit small

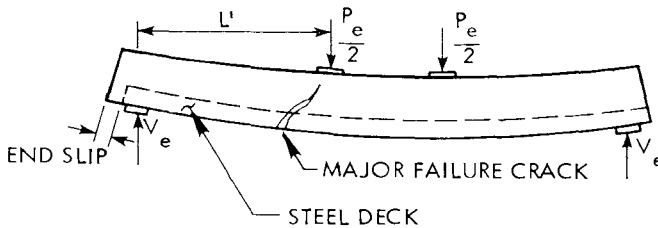

Fig. 4. Typical shear-bond failure.

amounts of displacement prior to ultimate failure; however, the total end slip is usually less than 0.06 inches at ultimate failure. Additional information concerning end slip is presented in another paper by the authors at this Conference.

The modes of flexural failure for under- or over-reinforced decks are similar to those in ordinary reinforced concrete. Failure of an under-reinforced deck is primarily characterized by yielding and possibly by tearing of the entire deck cross section at the maximum positive moment section. Conversely, failure of an over-reinforced deck is primarily characterized by crushing of the concrete at the maximum positive moment section. Small amounts of end slip may be experienced prior to flexural failure.

PERFORMANCE TEST PROGRAM

Performance tests are necessary since each steel deck profile has its own unique shear transferring mechanism. The purpose of the tests is to provide data for the ultimate strength design equations. In particular, a series of tests is needed in order to provide ultimate experimental shears for a linear regression analysis of the pertinent parameters affecting the shear-bond capacity. In cases involving the flexural mode of failure, tests should be performed to verify (if possible) the analysis.

Since the design of steel deck floor slabs is primarily based upon the load-carrying characteristics in a one-way direction (parallel to the deck corrugations), the performance tests are performed on one-way slab elements (see Fig. 5). The steel deck employed throughout a given performance test series consists of the same deck profile. The specimens are cast equivalent to those requirements as specified for

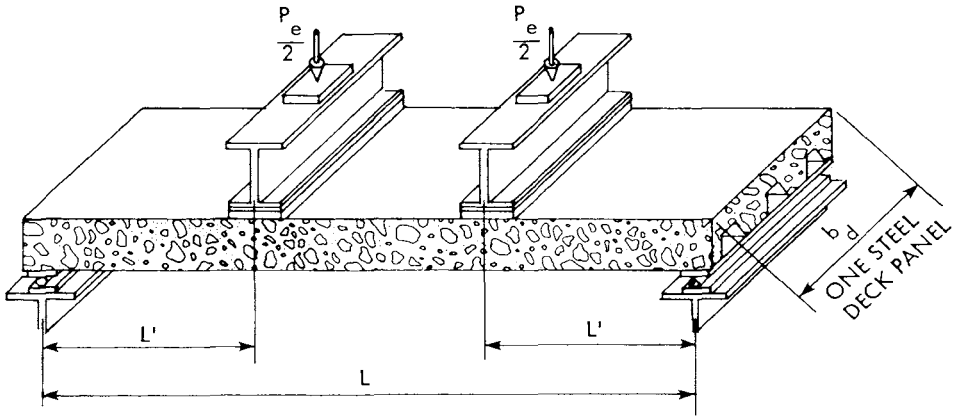

Fig. 5. Typical arrangement for testing one-way slab elements.

job site installation. The corresponding loading of the test specimen consists of two symmetrically placed line loads as shown in Fig. 5.

The performance test series requires a documentation of the pertinent parameters affecting the capacity of steel deck slabs. The primary test variables to be recorded include the following:

- 1) Deck manufacturer and type;
- 2) Shear span length, L' ;
- 3) Concrete properties, including age; compressive strength, f'_c ; basic mix design, type of concrete (light-weight or normal); and aggregate type and maximum size;
- 4) Steel deck properties, including cross-sectional area, A_s ; location of centroid of steel area, y_{sb} , from bottom; steel thickness, t_d ; depth of deck, d_d ; moment of inertia of steel deck, I_s ; yield strength, F_y ; modulus of elasticity, E_s ; and surface coating condition of deck;
- 5) Dead load;
- 6) Ultimate applied load, P_e , and type of load application;

- 7) Type of failure mode and description thereof;
- 8) Specimen dimensions, including width b ; length L ; and out-to-out depths, D , (average and at failure crack);
- 9) Spacing of mechanical shear transferring devices, s , where variable from one profile to another; and
- 10) Deflection and end-slip behavior.

For those specimens failing via the shear-bond failure mode, a plot is made of the parameter $V_e s / bd \sqrt{f'_c}$ as ordinates and $\rho d / L' \sqrt{f'_c}$ as abscissas (see Fig. 6). A linear regression is then performed to

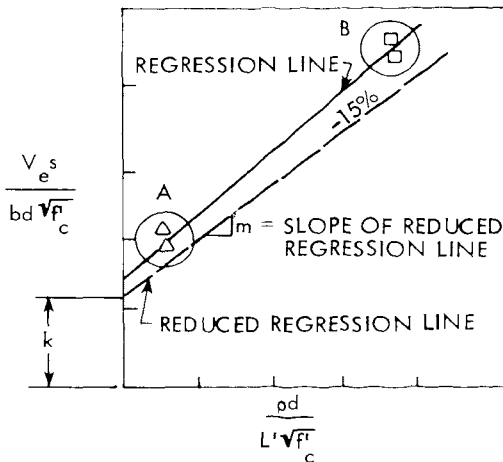

Fig. 6. Typical shear-bond failure relationships for a constant sheet thickness.

determine the slope, m , and intercept, k , in order to provide an equation formulation of the expected shear capacity:

$$\frac{V_u s}{bd \sqrt{f'_c}} = \frac{m \rho d}{L' \sqrt{f'_c}} + k \quad (1)$$

where the calculated ultimate shear capacity is defined as V_u , ρ is the reinforcement ratio (A_s/bd), d is the effective depth from the compression fiber to steel deck centroid, and the other symbols are as defined in the above list of parameters.

The development of Eq. 1 is based on the results of 151 tests made by various manufacturers and 304 tests conducted at Iowa State University. This equation is similar in form to Eq. 11-4 of the ACI Building Code (i). Examples of actual test results utilizing Eq. 1 are given by the authors in another paper at this Conference.

A reduced regression line is indicated in Fig. 6. This line is obtained by reducing the slope and intercept, respectively, of the original regression by 15 percent. The purpose of this reduction is to account for variations which occur in the test results. For design, the m and k employed in Eq. 1 should be those corresponding to the reduced regression line.

The "s" term in Eq. 1 accounts for the spacing of the shear transferring devices. The "s" term is taken as unity for those cases where the shear transfer device is at the same constant spacing (such as embossments) for all deck sections of the same basic profile or where the composite action is provided by the deck profile and the surface bond. An s-spacing other than unity is used only for those steel decks which have transverse wires, holes, or welded buttons where such devices may vary from one steel deck sheet to another. For example, on one deck sheet all wires might be spaced at three-inch centers, whereas on another deck sheet of the same profile the spacing of the wires may be at six-inch centers. Thus, "s" for the predicted shear-bond capacity

would be taken as three and six, respectively. Eq. 1 has not been verified for the deck where the spacing of the shear device varies along a single deck sheet. Current practice does not include decks of this type.

To establish the most representative linear relationship shown in Fig. 6, the full practical range of the values for the abscissa and the ordinate parameters is needed. Thus, a sufficient number of tests are needed to assure a good, representative regression line for m and k . This can be achieved with a minimum number of tests by using at least two specimens in each of the two regions A and B indicated in Fig. 6. Since the major variables are the depth, d , and the shear span, L' , a combination of changes affecting these two variables usually gives the desired spread for the regression plot. The shear span for region A should be as long as practical while still providing a shear-bond type of failure. For the other extreme, region B should have a shear span as short as possible, i.e., about 18 inches. Shear spans less than 18 inches are not recommended due to the effects of having the load too close to the reaction support.

The regression plot as shown in Fig. 6 is necessary for each steel deck profile, and, in addition, a separate regression is suggested for the following:

- 1) Each nominal gage thickness of steel,
- 2) Each surface coating, and
- 3) Each concrete type (i.e., light-weight vs normal weight).

For specimens involving the flexural mode of failure, the plotting of variables as indicated in Fig. 6 is not necessary. A minimum of

three flexural tests is recommended to verify the flexural analysis and the associated assumptions.

DESIGN EQUATIONS

The design of steel deck reinforced floor slabs is based upon maximum strength principles employing the same load factors and capacity reduction factors as for ordinary reinforced concrete systems (see Ref. 1). For example, the ultimate uniform design load, W_u , is

$$W_u = 1.4(W_1 + W_3) + 1.7LL \quad (2)$$

where

W_1 = Weight of slab (steel deck plus concrete dead load), psf

W_3 = Dead load applied to slab, exclusive of W_1 , psf

LL = Allowable superimposed live load for service conditions, psf

The maximum strength of a particular floor slab is found by considering each mode of failure as given below.

Shear-Bond

For convenience in design, Eq. 1 can be rearranged as follows:

$$V_u = \frac{bd}{s} \left(\frac{m_c d}{L'} + k\sqrt{f'_c} \right) \quad (3)$$

As described previously, the distance L' in Eq. 3 is the distance to the failure section of concentrated load systems. This L' is the distance from the end reaction to the concentrated load. For uniformly loaded systems, L' is taken as $L/4$, one-quarter of the span length. The

distance $L/4$ is found by equating areas of the shear diagram for the concentrated versus uniform load cases, as demonstrated in Fig. 7.

Figure 7 shows shear diagrams for concentrated and uniform load cases. The area of the left-hand portion of the shear diagram in case (a) is $(1/2)(V_u L/2)$, and the area under the shear diagram in case (b) of Fig. 7 is $V_u L'$. Equating cases (a) and (b) yields $L' = L/4$.

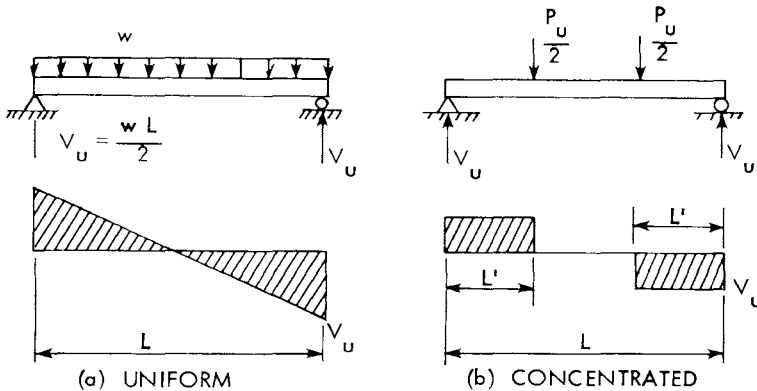

Fig. 7. Uniform and concentrated load application.

The above comparison of Fig. 7(a) and Fig. 7(b) for the same total applied loads provides for equal end shears and equal centerspan moments. The corresponding deflections are only ten percent greater at mid-span for the concentrated load case. Three pairs of tests of composite slabs with uniform versus concentrated loads indicate that the use of one-fourth span length for uniform cases appears reasonably valid. If several concentrated loads exist, the designer may elect to treat the system as an equivalent uniformly loaded beam.

Combinations of uniform and concentrated load systems may require special attention for the proper selection of the L' distance. In certain instances, the loading combination may require tests to determine the proper L' for use in Eq. 3. In lieu of tests, the finding of an equivalent L' based on equating shear areas may suffice to give an approximate L' for the most common load combinations. The method of equating shear areas relates the design load to the experimental test load configuration used to obtain the m and k constants. The procedure for obtaining an L' distance for the combination of uniform load and concentrated load at midspan is shown in Fig. 8. The shear area for case 1 is

$$\frac{P_1}{2} \left(\frac{L}{2} \right) + \left(\frac{wL}{2} \right) \left(\frac{L}{2} \right) \left(\frac{1}{2} \right)$$

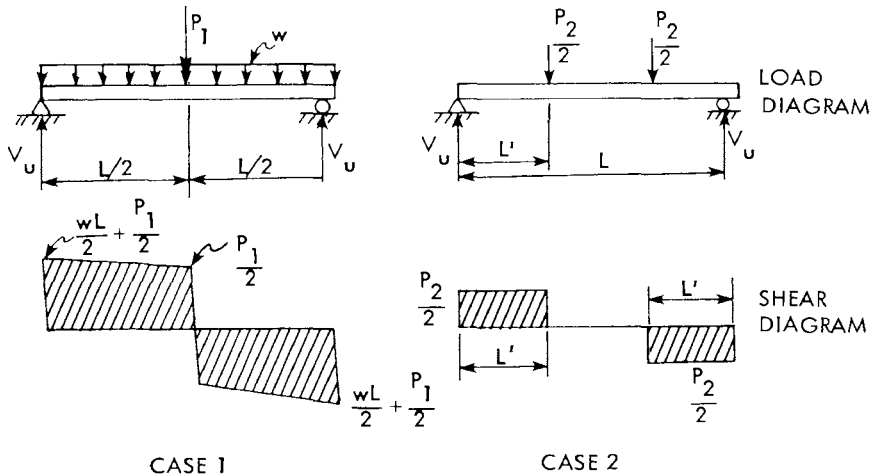

Fig. 8. Uniform load in combination with a single concentrated load placed at midspan compared with two concentrated loads.

whereas the shear area for case 2 is

$$\frac{P_2}{2}(L')$$

Replacing the term P_2 with $P_1 + wL$, and equating the expressions for the shear areas yields

$$L' = \left(\frac{P_1 L}{4} + \frac{wL^2}{8} \right) \left(\frac{P_1}{2} + \frac{wL}{2} \right)$$

The above equation applies for the range $L/4 \leq L' \leq L/2$ for various combinations of P_1 and w .

Most floor slab designs are based on a uniform load. Thus, substituting for L' , one-fourth the span length, L , in feet, including a capacity reduction factor, ϕ , and adding a shoring correction term, allow Eq. 3 to be written on a per foot of width basis as

$$V_u = \phi \left[\frac{d}{s} \left(\frac{4m_f d}{L} + 12k \sqrt{f'_c} \right) + \frac{\gamma W_1 L}{2} \right]$$

or

$$V_u = \phi \left[\frac{d}{s} \left(\frac{mA_s}{3L} + 12k \sqrt{f'_c} \right) + \frac{\gamma W_1 L}{2} \right] \quad (4)$$

The recommended capacity reduction factor, ϕ , for shear-bond is 0.80. The term $\gamma W_1 L/2$ accounts for the amount of dead load carried by the floor system in composite action. Table 1 gives values of γ to account for the support (shoring) condition during casting, where γ is the portion of the dead load added upon removal of the shore support.

Table 1. Values of γ for Various Support Conditions.

Support condition	γ
Complete Support	1.0
Unshored	0.0
Shored at center	0.625

The "complete support" condition means that the steel deck is uniformly supported during casting along its entire length and thus is not carrying any dead load during construction. Therefore, upon removal of the complete support, all of the dead load is carried by composite section. The "complete support" condition usually applies only to specimens cast in the laboratory.

The opposite case is that of the completely unshored or unsupported deck. For this case, the steel deck carries all of the dead load during casting and no dead load is carried compositely.

The case of the slab supported at the center (shored) is illustrated in Fig. 9. During casting part of the dead load is carried by the shore support. When the shore is removed, the maximum shear added to the composite section is $(5/8)(W_1L/2)$ or $\gamma = 5/8 = 0.625$ as given in Table 1.

The three most common support conditions are given in Table 1 as a means of illustrating a determination of γ . For cases involving two or more supports, the additional γ factors should be determined in a manner similar to that shown in Fig. 9. The three γ factors given in Table 1 are for simple span systems. Thus, based on Eq. 2, the

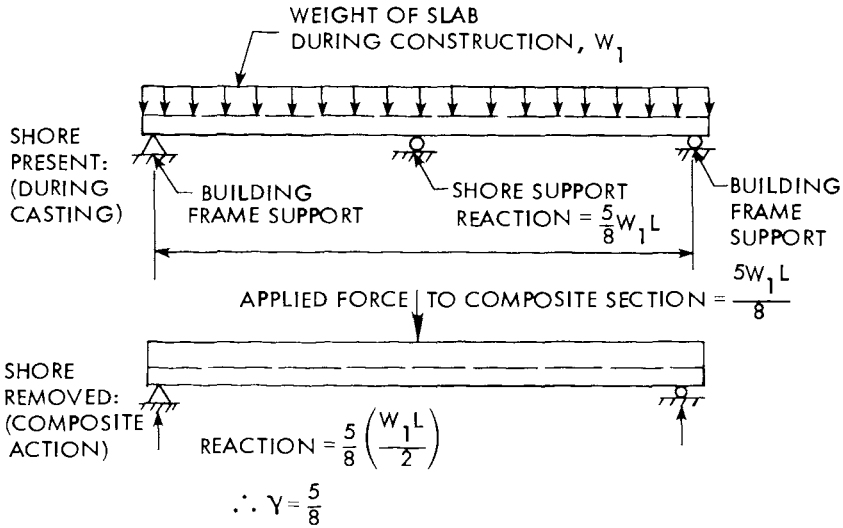

Fig. 9. Illustration of γ for case of single shore at center of span.

allowable uniform superimposed live load (LL) in pounds per square foot is

$$LL = \frac{1}{1.7} \left[\frac{2V}{L} - 1.4(\gamma W_1 + W_3) \right] \tag{5}$$

Another approach may be used to correct the shoring condition. This approach involves correcting the experimental shears obtained in the performance tests by the amount of dead load acting on the composite system. With this technique, the regression constants m and k in Eqs. 1 and 3 include the shoring correction, and therefore a γ correction is unnecessary in Eqs. 4 and 5. Evaluation of test results indicates

that this latter technique for shoring correction gives satisfactory results for performance tests involving more than one shoring condition.

Flexure

Flexural capacities are separated into over- and under-reinforced sections according to the balanced steel ratio, ρ_b , as defined by

$$\rho_b = \frac{0.85\beta_1 f'_c}{F_y} \left[\frac{87,000 (D - d_d)}{(87,000 + F_y) d} \right] \quad (6)$$

This equation is developed from the compatibility of strains and the equilibrium of internal forces. The resultant steel force is assumed to act at the centroid of the cross-sectional area of the steel deck. The term $(D - d_d)/d$ is based on yielding across the entire deck cross section when the concrete strain reaches 0.003, and thus the equation is valid only if the entire deck section yields.

The calculated ultimate moment, M_u , in foot-pounds per foot of width for the under-reinforced case is found by the conventional equation

$$M_u = \frac{\phi A_s F_y}{12} \left(d - \frac{a}{2} \right) \quad (7)$$

where ϕ = Flexural (under-reinforced) capacity reduction factor = 0.90

a = Depth of equivalent rectangular stress block $(A_s F_y)/(0.85 f'_c b)$

and the other symbols as previously given.

This equation assumes that the force in the steel acts at the deck cgs

and that no additional reinforcing is present (or to be counted upon for positive bending).

Equation 7 gives the ultimate moment on a plane section perpendicular to the steel deck corrugations. It is the familiar equation used in reinforced concrete design according to the ACI Code and Commentary (1).

For Eq. 7 to be valid, the following conditions must be met:

- 1) The entire steel deck profile is at yield stress,
- 2) The entire area of steel deck can be reasonably assumed to be concentrated at the cgs of the steel deck,
- 3) The concrete reaches a maximum compressive strain of 0.003 in./in. at its outermost compression fibers, and
- 4) No additional steel reinforcement exists.

Normally, Eq. 7 can be used for an under-reinforced section, however, one or more of the above-listed four conditions may not be true. For example, a very deep deck having a composite ultimate neutral axis within the deck profile may not reach yield at the top fiber at the ultimate flexural capacity. Also, a steel deck made with a steel having a low ductility may tear or fracture prior to the concrete achieving a strain of 0.003. These conditions are in no way detrimental to the particular steel deck system. They only dictate that a more general flexural strain analysis which considers compatibility of strains together with equilibrium be used.

The calculated ultimate moment for the over-reinforced case is

$$M_u = \frac{\phi 0.85 R_c f'_c b d^2 k_u}{12} (1 - R_2 k_u) \quad (8)$$

where

ϕ = flexural (over-reinforced) capacity reduction factor = 0.75

β_1 = 0.85 for concrete with $f'_c < 4000$ psi, and is reduced at the rate of 0.05 for each 1000 psi of strength exceeding 4000 psi

β_2 = 0.425 for $f'_c \leq 4000$ psi, and is reduced at the rate of 0.025 for each 1000 psi of strength exceeding 4000 psi

$$k_u = \sqrt{\rho\lambda + \left(\frac{\rho\lambda}{2}\right)^2} - \frac{\rho\lambda}{2}$$

$$\lambda = \frac{E_s \epsilon_u}{0.85\beta_1 f'_c}$$

ϵ_u = maximum concrete compression strain at ultimate strength in./in. (taken as 0.003)

The development of Eq. 8 is based upon strain compatibility and internal force equilibrium as described in Refs. 9 and 12. Equation 8 assumes that the concrete reaches a strain of 0.003 prior to yielding of the entire steel deck section. In some cases a deck section could have insufficient ductility to allow the concrete strain to reach 0.003 and still be classed as over-reinforced. If this situation exists, a more general flexural strain analysis is necessary.

ADDITIONAL DESIGN CONSIDERATIONS

Casting and Shoring Requirements

During the construction stages, the steel deck carries the entire wet weight of the concrete in addition to its own weight and any applied construction loads. The steel deck section properties such as cross-sectional area and moment of inertia for the construction

stages are determined according to the provisions of AISI's "Specifications for the Design of Cold-Formed Steel Structural Members" (2). These section properties are normally tabulated in each steel deck manufacturer's catalog on a per foot of width basis. In addition, the allowable steel stresses during the construction stages are also given in Ref. 2. The maximum steel stresses due to bending are determined by the conventional elastic flexural equation

$$f_b = \frac{M}{S} \quad (9)$$

where

f_b = bending stress

M = moment due to construction live load, concrete dead load, and steel deck dead load

S = appropriate effective section modulus, either positive or negative.

The minimum construction live loads applied to the steel deck in addition to the concrete weight are 20 psf uniform or 150 lb per-foot-of-width concentrated load. Consideration should also be given to high transient loads which may occur during the construction phase.

The deflection of the deck under the weight of wet concrete usually results in a variable depth of concrete. This is because the top of the slab is normally finished to conform to ACI finishing tolerances, and consequently the depth of concrete is greatest at the point of largest deck deflection. The increased weight of concrete should be considered in all computations. For very short spans this increased weight due to deflections is quite small, but for longer spans this weight may be significant.

The computation of the increased weight due to deflection is somewhat similar to the problem of ponding. An approximate solution to this ponding problem consists of assuming the deflected shape as a parabola. In this case, the area of the deflected portion is $(2/3)(\Delta_1)(L)$ for a simple span system where Δ_1 is the deflection due to the initial uniform thickness. A new Δ_1 could then be found by taking the new weight as applied to the decking.

The deflection of the steel deck during the construction stages is usually limited to $L/180$ or $3/4$ inch, whichever is smaller. The span length, L , is the clear span between temporary or permanent supports.

Temporary supports or shoring is necessary for cases involving long spans where steel deck stresses or deflections exceed the maximum recommended values. Since the steel deck is usually designed to carry all construction loads in a one-way direction (parallel to deck corrugations), any necessary shoring consists of one or more line supports parallel to the support beams carrying the end reactions.

Deflections

Deflection limitations for the design of composite steel deck floor slabs generally follow the provisions of Section 9.5 of the ACI Building Code (1). Thus, deflections are computed at service load levels and the long-time deformations are added to the short-time ones.

The effective moment of inertia for composite deck deflection computations is taken as simply the average of the standard cracked and

uncracked section concepts. Figure 10 indicates the pertinent distances that are employed for finding the moment of inertia.

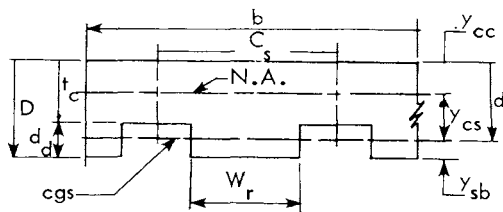

Fig. 10. Transformed composite section with neutral axis above the steel deck.

In Fig. 10, y_{cc} is the distance to the neutral axis and is found from the conventional expression for a cracked section, i.e.,

$$y_{cc} = d \left[\left(2\rho n + (\rho n)^2 \right)^{1/2} - \rho n \right] \quad (10)$$

where

n = modular ratio = ratio of modulus of elasticity of steel, E_s , to that of concrete, E_c .

For cases where the neutral axis is within the steel deck section, the distance y_{cc} can be taken conservatively as equal to the thickness of concrete above the deck, t_c . The corresponding cracked moment of inertia is found from

$$I_c = \frac{b}{3}(y_{cc})^3 + nA_s(y_{cs})^2 + nI_{sf} \quad (11)$$

where I_{sf} is the moment of inertia of the entire steel deck cross section.

Based upon uncracked section concepts, the neutral axis location can be obtained from

$$y_{cc} = \frac{0.5bD^2 + nA_s d - (C_s - W_r) \frac{bd}{C_s} (D - 0.5d)}{bD + nA_s - \frac{b}{C_s} d (E_s - W_r)} \quad (12)$$

The resulting uncracked moment of inertia is

$$I_u = \frac{bt_c^3}{12} + bt_c (y_{cc} - 0.5t_c)^2 + nI_{sf} + nA_s y_{cs}^2 + \frac{W_r bd}{C_s} d \left[\frac{d^2}{12} + (D - y_{cc} - 0.5d)^2 \right] \quad (13)$$

and the effective moment of inertia, I_e , for composite steel deck deflection computations is

$$I_e = \frac{I_c + I_u}{2} \quad (14)$$

The above approximate effective moment of inertia method was arrived at through an inspection of test results from the ISU research program (6).

Span and Depth Relations

As a guide, the following maximum span-to-depth ratios should provide satisfactory results:

- 10 for cantilevers,
- 22 for simply supported spans,

27 for one end continuous spans, and

32 for both ends continuous spans.

These ratios are based upon industry-wide experience and commonly accepted practice and usually provide satisfactory deflection limitations under static short-time service loads for members not supporting or attached to partitions or other construction likely to be damaged by large deflections. These span-to-depth ratios are not intended to substitute for deflection computations. The above span-to-depth ratios are slightly higher than conventionally reinforced concrete since the composite deck slab has the advantage of having more steel closer to the bottom of the slab. Floors subject to vibrating machinery and other dynamic types of loadings may necessitate a lowering of the above ratios.

The minimum recommended depth of a steel deck reinforced floor slab is 3-1/2 inches. This depth is considered a minimum in order to provide for adequate cover, placement of supplemental steel for shrinkage and temperature requirements, and stiffness of the slab. The minimum recommended cover depth over the deck is 1-1/2 inches with a 3/4-inch minimum cover for any supplemental reinforcement. Additional recommendations for cover and spacing distances can be found in the ACI Code (1).

SUMMARY

The recommended design procedures for composite steel-deck-reinforced floor slabs utilize the application of the maximum strength concepts. The design capacity is primarily based upon the computation

of the shear-bond strength. However, the computations of the conventional under- and over-reinforced flexural capacities are also required. In some instances, a more general flexural strain analysis which considers compatibility of strains together with equilibrium is necessary when the conventional flexural equations are not valid.

The design equations for the shear-bond capacity are derived from data obtained by means of a performance test series. A plot of the parameters $v_e s / bd \sqrt{f'_c}$ and $\rho d / L' \sqrt{f'_c}$ is made, and a linear regression is performed to determine the slope and intercept constants needed for design. A separate regression is necessary for each steel deck profile, and, in addition, a separate regression is suggested for each steel gage thickness, steel surface coating, and concrete type.

During the construction phase, the steel deck serves as the structural load carrying element. The design for this loading is determined by conventional elastic analysis based on the steel deck supporting the entire wet weight of the concrete in addition to its own weight and any applied construction loads.

Design for deflection limitations for the composite steel deck slab system generally follow current practice as provided in the ACI Building Code. The effective composite moment of inertia for deflections is taken as a simple average of the cracked and uncracked section concepts.

ACKNOWLEDGMENTS

The proposed design criteria presented in this paper are part of the American Iron and Steel Institute's (AISI) latest draft of "Tentative Recommendations for the Design of Composite Steel Deck Slabs and Commentary." The design criteria is based upon an extensive theoretical and experimental research program sponsored by AISI and conducted by the Engineering Research Institute of Iowa State University. Valuable guidance in the conduct of this research was provided by the AISI's Task Committee on Composite Construction of the Joint Engineering Subcommittee of the Committees of Hot Rolled and Cold Rolled Sheet and Strip Producers and Galvanized Sheet Producers under chairmanship of Mr. T. J. McCabe and past chairman Mr. A. J. Oudheusden.

REFERENCES

1. American Concrete Institute, "Building Code Requirements for Reinforced Concrete" (ACI 318-71, with 1973 Supplement), and Commentary thereon, as published by the American Concrete Institute, Box 19150, Detroit, Michigan 48219.
2. American Iron and Steel Institute,
 - Part I: "Specification of the Design of Cold-Formed Steel Structural Members," 1968 edition with Addendum No. 1, November 19, 1970
 - Part II: "Supplementary Information"
 - Part III: "Illustrative Examples"
 - Part IV: "Charts and Tables"
 - Part V: "Commentary" by George Winterpublished by the American Iron and Steel Institute, 1000 16th Street, N.W., Washington, D.C. 20036.
3. Ekberg, C. E., Jr., and Schuster, R. M., "Floor Systems with Composite Form-Reinforced Concrete Slabs," Eighth Congress of the International Association for Bridge and Structural Engineering, Final Report, Zurich (1968): 385-394.
4. Porter, M. L., "The Behavior and Analysis of Two-way Simply Supported Concrete Floor Slabs Constructed with Cold-Formed Steel Decking," Ph.D Thesis, Iowa State University, Ames, Iowa, 1974.
5. Porter, M. L., "Investigation of Light Gage Steel Forms as Reinforcement for Concrete Slabs," Unpublished M.S. Thesis, Library, Iowa State University, Ames, Iowa, 1968.
6. Porter, M. L., and Ekberg, C. E., Jr., Discussion of paper by the Subcommittee on the State-of-the-Art Survey of the Task Committee on Composite Construction of the Committee on Metals of the Structural Division entitled "Composite Steel-Concrete Construction," ASCE Journal of the Structural Division, Vol. 101, No. ST3, March 1975.
7. Porter, M. L. and Ekberg, C. E., Jr., "Summary of Full-Scale Laboratory Tests of Concrete Slabs Reinforced with Cold-Formed Steel Decking," Ninth Congress of the International Association for Bridge and Structural Engineering, Preliminary Report, Zurich (1972): 173-183.
8. Proceedings of First Specialty Conference on Cold-Formed Steel Structures, August 19-20, 1971, Department of Civil Engineering, Continuing Education Series, University of Missouri-Rolla.
9. Ramakrishnan, V., and Arthur, P. D., "Ultimate Strength Design for Structural Concrete," Pitman Publishing Corporation, New York, 1969, pp. 9-10.

10. Schuster, R. M., "Composite Steel-Deck-Reinforced Concrete Systems Failing in Shear-Bond," Ninth Congress of the International Association for Bridge and Structural Engineering, Preliminary Report, Zurich (1972), 185-191.
11. Schuster, R. M., "Strength and Behavior of Cold-Rolled Steel-Deck Reinforced Concrete Floor Slabs," Ph.D Thesis, Iowa State University, Ames, Iowa, 1970.
12. Winter, George and Nilson, A. H., Design of Concrete Structures, 8th edition, McGraw-Hill Book Company, New York, 1972.

APPENDIX - NOTATION

- a = depth of equivalent rectangular stress block,

$$\frac{A_s F_y}{0.85 f'_c b}$$
- A_s = cross-sectional area of steel deck where used as tension reinforcement, in.²/ft. of width
- b = unit width of slab, usually taken as 12 in.
- b_d = width of composite test slab, ft.
- c.g.s. = centroidal axis of full cross-section of steel deck
- C_s = cell spacing, in.
- d = effective slab depth (distance from extreme concrete compression fiber to centroidal axis of the full cross-sectional area of the steel deck), in.
- D = nominal out-to-out depth of slab, in.
- d_d = depth of steel deck profile, in.
- E_s = modulus of elasticity of steel deck, 29,500,000 psi
- f_b = bending stress in steel deck, psi
- f'_c = 28-day compressive test cylinder strength, psi
- F_y = yield point or yield strength of steel, psi
- I_s = effective positive or negative bending moment of inertia of steel deck, in.⁴/ft. of width
- I_{sf} = moment of inertia of steel deck per foot of width based on full cross-section deck area, in.⁴/ft. of width
- k_u = ratio defining position of neutral axis at failure,

$$k_u = \sqrt{\rho\lambda + \frac{\rho\lambda}{2}} - \frac{\rho\lambda}{2}$$
- L = length of span, ft.
- L' = length of shear span, in., for uniform load, L' = 12L/4
- LL = allowable superimposed live load for service conditions, psf

- m = slope of regression line
 M = moment, in.-lb
 n = the modular ratio, E_s/E_c
 N.A. = neutral axis of transformed composite section
 P_1 = concentrated live load of loading case one, lb.
 P_2 = concentrated live load of loading case two, lb.
 P_e = maximum applied experimental slab load at failure obtained from laboratory tests, lb. (including weight of loading system but not weight of slab)
 s = center-to-center spacing of shear transfer devices other than embossments, in.
 S = elastic effective section modulus of steel deck, in.³/ft. of width
 t_c = depth of concrete above steel deck, in.
 t_d = steel thickness exclusive of coating, in.
 V_e = maximum experimental shear at failure as obtained from laboratory tests, lb./ft. of width (not including weight of slab)
 V_u = calculated ultimate shear based on shear-bond failure, lb./ft. of width
 w = uniform load, psf
 W_1 = weight of slab ($DL_d + DL_c$), psf
 W_3 = dead load applied to slab, exclusive of W_1 , psf
 W_u = calculated ultimate uniformly distributed load, psf
 W_r = average rib width, in.
 y_{cc} = distance from neutral axis of composite section to top of slab, in.
 y_{cs} = distance from neutral axis of composite section to centroidal axis of steel deck, in.
 y_{sb} = distance from centroidal axis of steel deck to bottom of steel deck, in.
 R_1 = equals 0.85 for concrete with $f'_c \leq 4000$ psi and is reduced at a rate of 0.05 for each 1000 psi of strength above 4000 psi

- β_2 = equals 0.425 for $f'_c \leq 4000$ psi, and is reduced at a rate of 0.025 for every 1000 psi of strength above 4000 psi
- Δ_1 = deformation of steel deck due to net weight of concrete
- γ = coefficient depending on support during curing
- ϵ_u = maximum concrete compression strain at ultimate strength, in./in.
- λ = elastic modular ratio,
- $$\frac{E_s \epsilon_u}{0.85 \beta_1 f'_c}$$
- ϕ = capacity reduction factor
- ρ = reinforcement ratio, A_s/bd
- ρ_b = reinforcement ratio producing balanced conditions